

ALGIERS PEDIATRIC

FRAME SCHEDULE

TUBELITE E/T34000 : Storefront : StormMax : Center Set : 2-1/2 x 5 : 1-5/16 in. Impact Glass : Dry Glazed

DOOR SCHEDULE

TUBELITE BRAND MEDIUM (IMPACT) W/ HARDWARE SHOWN ON SCHEDULE

GLASS SCHEDULE

- G1- VIRACON 1/4" CLEAR HS, VUE-50 #2 1/2" AIRSPACE 1/4" CLEAR HS 090 PVB 1/4" CLEAR HS
- G2- OLDCASTLE 1/4" CLEAR TEMP(.090 PVB) 1/4" CLEAR TEMP
- G3- OLDCASTLE 3/16" CLEAR AN 30CL 3/16" CLEAR AN
- G4- OLDCASTLE 1/8" VELOUR CLEAR AN 30CL 1/8" CLEAR AN (ACID ETHCED)
- G5- OLDCASTLE 1/4" CL TP

VINYL OR SEALANTS SCHEDULE

- P6586 - INTERIOR WEDGE
- P6503 - EXTERIOR GASKET
- DOW CORNING 795

FINISHES

ANNODIZED

FLASHING

STANDARD FLASHING MANUFACTURED BY TUBELITE.

HARDWARE SCHEDULE

- MFG STD BUTT HINGES
- MFG STD PUSH/PULLS
- MFG STD SURFACE CLOSERS
- MFG STD WEATHER SEALS
- MFG STD THRESHOLD

Algiers or Milne School?

Is this schedule for Algiers or Milne School?

LEGENDS / ABBREVIATIONS

- SHEET NO.1 COVER SHEET
- SHEET NO.2 ELEVATION Q1
- SHEET NO.3 ELEVATION P1, N1-N2
- SHEET NO.4 ELEVATION H1-H2
- SHEET NO.5 ELEV/ DOOR G1-G4
- SHEET NO.6 DETAILS
- SHEET NO.9 VIRACON GLASS PERFORMANCE
- SHEET NO.10 OLDCASTLE GLASS PERFORMANCE
- SHEET NO.11 OLDCASTLE GLASS PERFORMANCE

ARCHITECT AND CONTRACTOR NOTE

THESE SHOP DRAWINGS SHOW OUR INTERPERATION OF THE PROJECT AND ARE SUBMITTED FOR APPROVAL. OUR RESPONSIBILITY SHALL BE LIMITED TO FURNISHING, FABRICATING AND INSTALLING THE MATERIALS IN ACCORDANCE WITH THESE APPROVED DETAILS.

ALL DIMENSIONS TO BE VERIFIED IN THE FIELD. UNLESS OTHERWISE SPECIFIED WE WILL FABRICATE AND INSTALL TO SHOWN DIMENSIONS.

MATERIALS WILL BE RELEASED ONLY UPON ACCEPTANCE OF SIGNED DRAWINGS BY THE ARCHITECT AND BY THE GENERAL CONTRACTOR OR WRITTEN REQUEST OF THE GENERAL CONTRACTOR.

IF HARDWARE IS TO BE FURNISHED BY OTHERS, TEMPLATES AND PHYSICAL HARDWARE MUST BE IN OUR POSSESSION OR IN THE POSSESSION OF OUR FABRICATOR PRIOR TO FABRICATION.

EXCLUSIONS

ALL SUBSTRATE BUILDING MATERIALS SHOWN IN THE DETAILS PORTION OF THIS SHOP DRAWING ARE TO BE SUPPLIED, FABRICATED, AND INSTALLED "BY OTHERS" UNLESS SPECIFICALLY NOTED OTHERWISE. (I.E BRICK, CMU, E.I.F.S., WOOD BLOCKING, STUCCO ON METAL LATHE, GYPSUM BORD, SHEATHIN, METAL OR WOOD STUDS, STRUCTURAL STEEL, STEEL ANGLES, STEEL LINTEL, POUR STOPS, INSULATION, METAL PANELS AND TRIM, SUSPENDED CEILING, METAL TRIM, THRU-WALL FLASHING, INTERIOR CAULING,

patrick schwall - 10

ARCHITECT
WAGGONNER & BALL ARCHITECTS
CONTRACTOR
CDW ENTERPRISES

PROJECT
MILNE

GLAZING CONTRACTOR
STAR GLASS INC

SHEET NO. OF

DRAWINGS PREPARED BY STAR GLASS INC

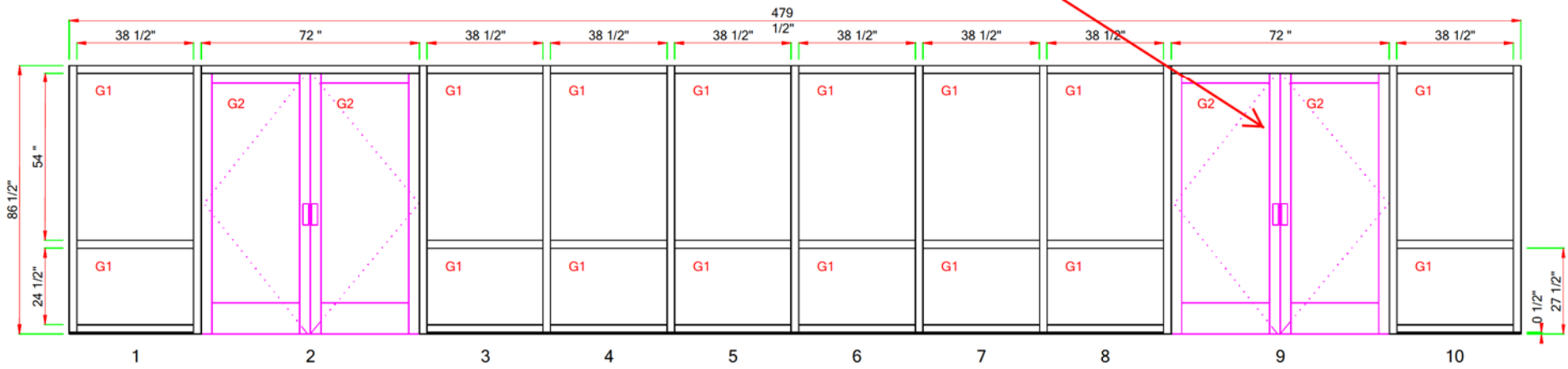

What are the dimensions of the visible glass area? Not the dimensions of the entire glass as it fits into the frame.

MILNE SCHOOL - CDW - 001 - MARK Q1.dwg (1 Thus)
Not to Scale! This elevation has been scaled down to fit the page.

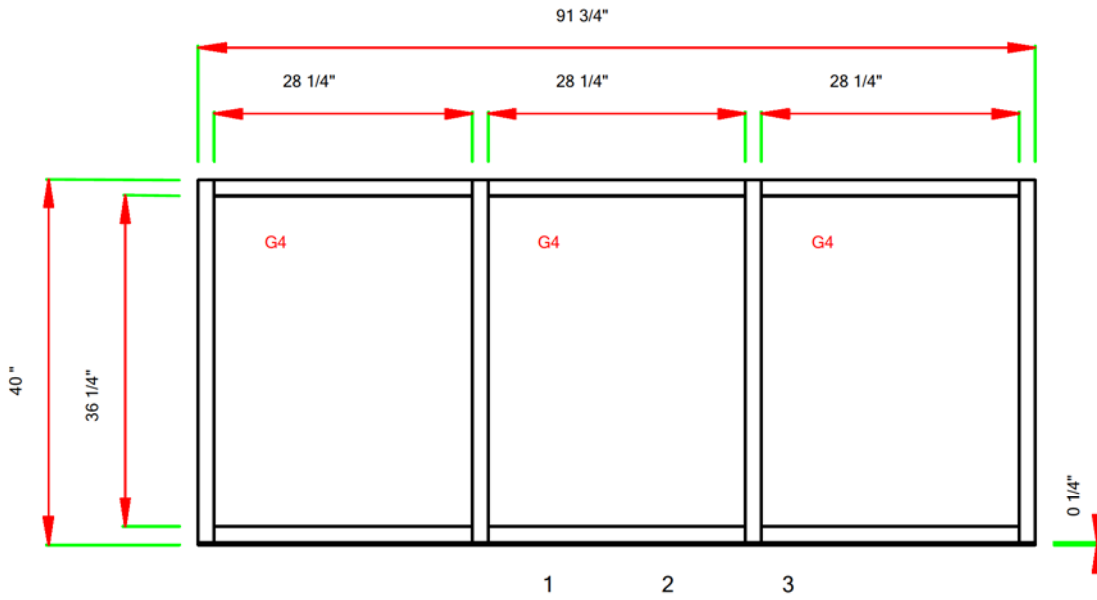

MILNE SCHOOL - CDW - 002 - MARK P1.dwg (1 Thus)

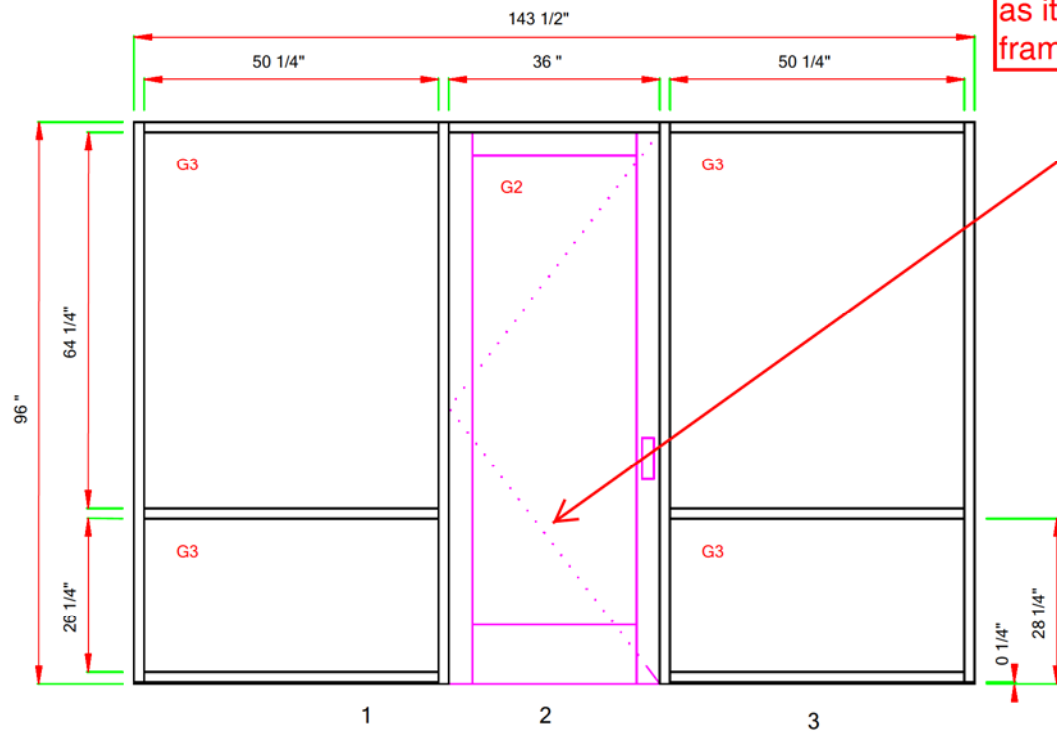

MILNE SCHOOL - CDW - 003 - MARK N1-N2.dwg (1 Thus)

What are the dimensions of the visible glass area? Not the dimensions of the entire glass as it fits into the frame.

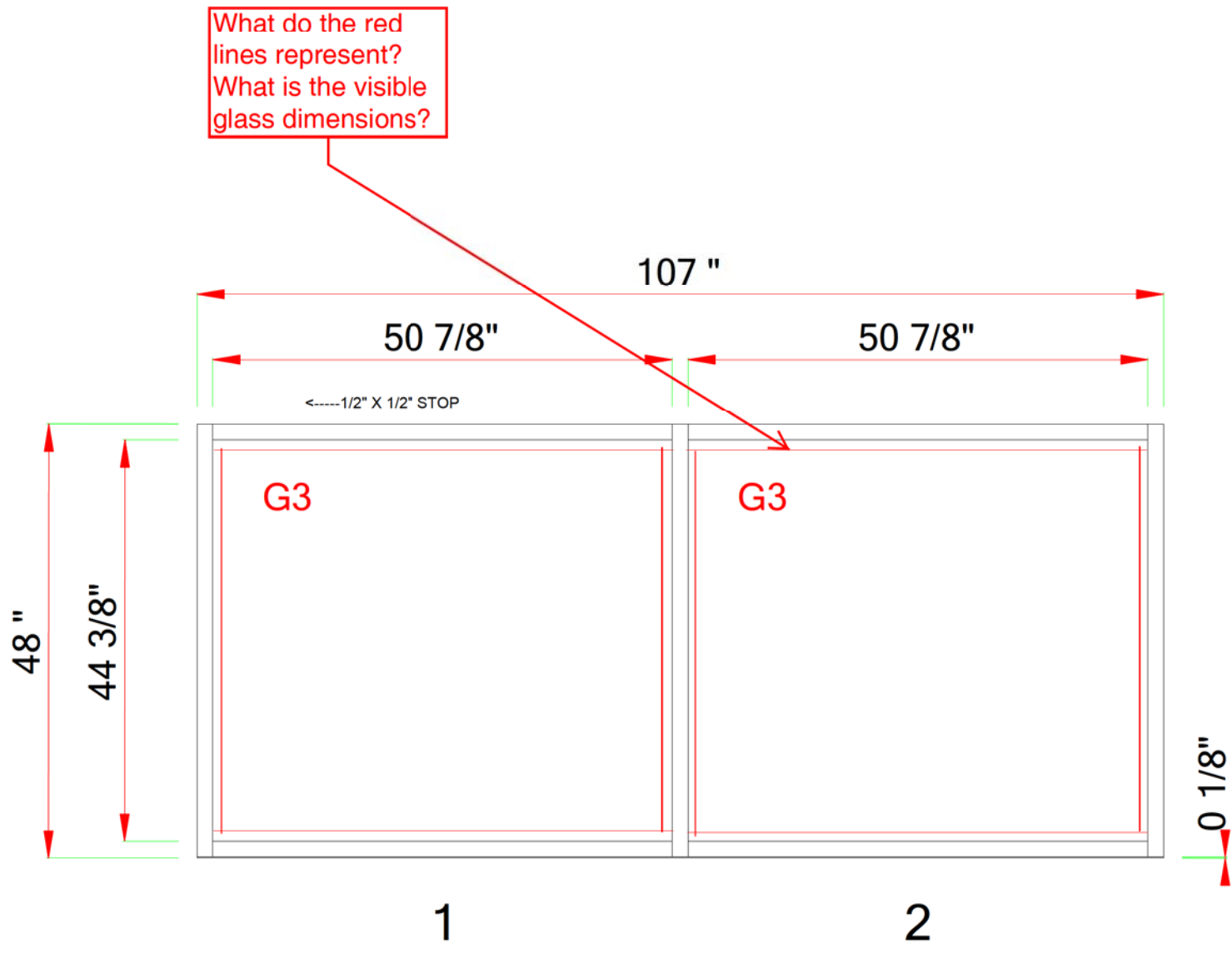

MILNE MUNICIPAL BOYS HOME - 005 - MARK H1-H2.dwg (2 Thus)

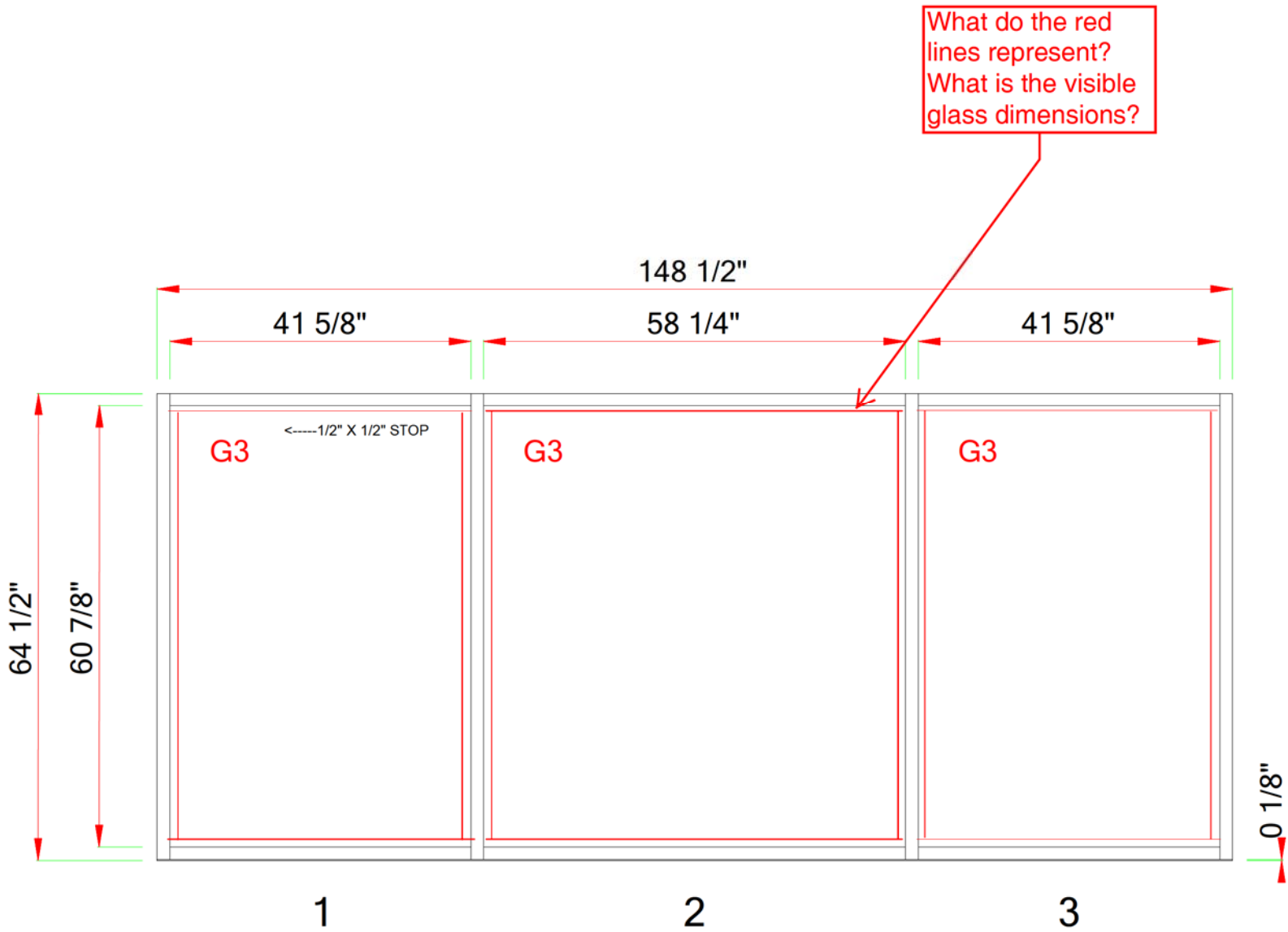

MILNE MUNICIPAL BOYS HOME - 004 - MARK G1-G4.dwg (4 Thus)

GLAZING CONTRACTOR
STAR GLASS INC

PROJECT
MILNE

ARCHITECT
WAGGONER & BALL ARCHITECTS
CONTRACTOR
CDW ENTERPRISES

patrick schwall - 10

SHEET NO. OF

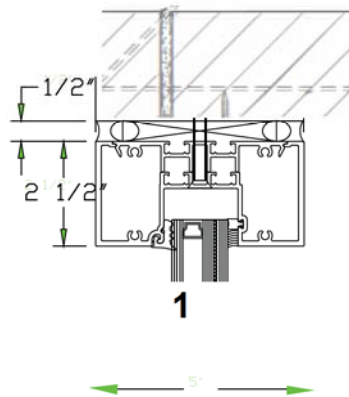
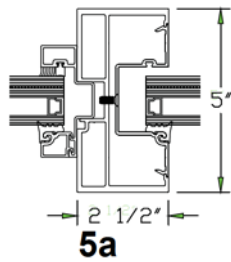
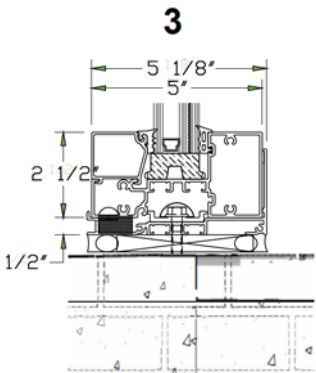
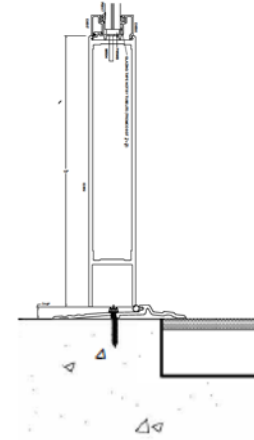
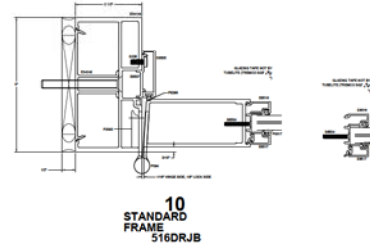
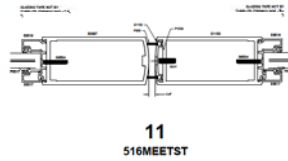
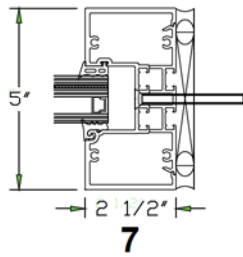
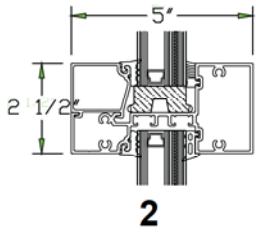
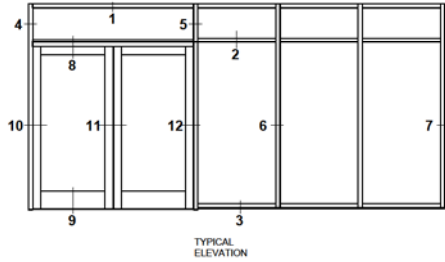

FASTEN STOPS WITH
#8 x 7/8" S.S. OVAL-
HEAD SCREWS @ 12" o.c.
(DO NOT PAINT SCREWS)

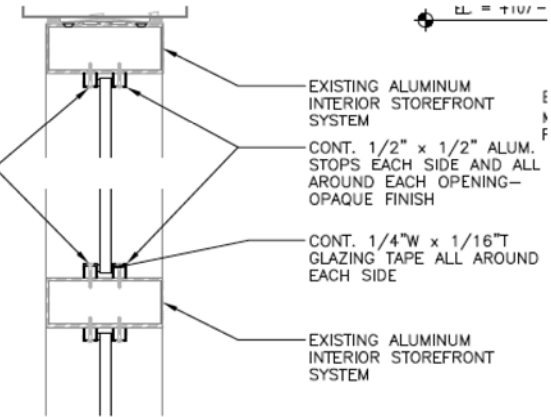

FORCEFRONT STORM

E/T34000 Storefront

800-866-2227 / www.tubelite.com

ForceFront Storm® E/T34000 Storefront is a 2-1/2" x 5"

[ASTM E1886-05 / 1996-09, TAS 201-94 and TAS 203-94].

flush glazed system for use on low-rise single span applications in hurricane impact areas. The system meets the requirements of Florida Building Code High Velocity Hurricane (HVHZ) Zone 4 - large missile impact and cycling thermal barrier with Azon's Lancer™ technology that ensures compliance to stringent energy codes.

Features include screw spline frame construction, exterior center set glazing, heavy duty vertical mullion, and accepts 1-5/16" insulated laminated glass installed using wet-

to fabricate and install.

ForceFront Storm Curtainwall (FFS-CW) and Medium and Monumental Entrance Doors compliment the storefront, providing a complete hurricane resistant system that's easy from Linetec.

ForceFront Storm Storefront products are available with Tubelite's high recycled aluminum content, Ecoluminum, and environmentally friendly paint and anodize finishes

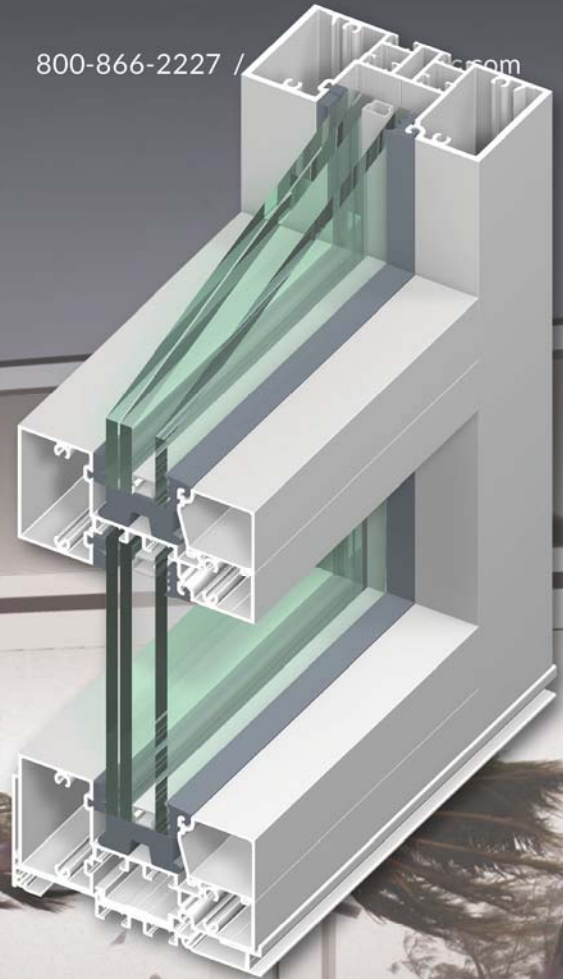

TUBELITE®

DEPENDABLE

LEADERS IN ECO-EFFICIENT STOREFRONT,
CURTAINWALL AND ENTRANCE SYSTEMS



Tubelite ForceFront Storm® E/T34000 Storefront

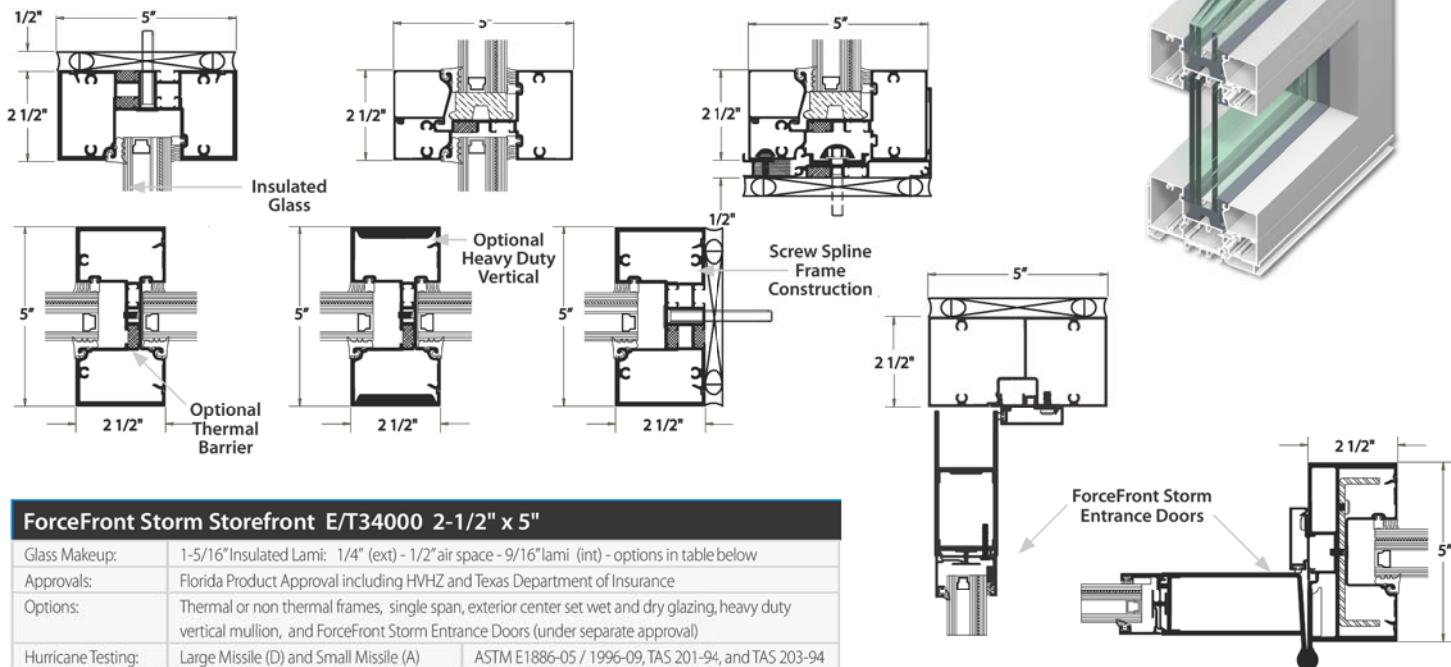

GET THE POINT!®
 E34000 Storefront can help with the following LEED points:
 • MR 4.1 & 4.2 Recycled Content
 • EQ 8.1 & 8.2 Daylight & Views

ForceFront Storm Storefront E/T34000 2-1/2" x 5"		
Glass Makeup:	1-5/16" Insulated Lami: 1/4" (ext) - 1/2" air space - 9/16" lami (int) - options in table below	
Approvals:	Florida Product Approval including HVHZ and Texas Department of Insurance	
Options:	Thermal or non thermal frames, single span, exterior center set wet and dry glazing, heavy duty vertical mullion, and ForceFront Storm Entrance Doors (under separate approval)	
Hurricane Testing:	Large Missile (D) and Small Missile (A)	ASTM E1886-05 / 1996-09, TAS 201-94, and TAS 203-94
Air Infiltration:	0.06 cfm/ft2 @ 6.24 psf	ASTM E283-04 and TAS 202-94
Water Resistance:	15 psf (static)	ASTM E331-00, TAS 202-94
U-Value:	0.37 (thermal option)	NFRC 100, glazed wall configuration
CRF (frame):	59 (thermal option)	AAMA 1503
STC:	36 (.090 Sentry lami)	ASTM E90-09
OITC:	32 (.090 Sentry lami)	ASTM E1332-10a
Structural:	up to +70 / -68 psf	ASTM E330-02 and TAS 202-94

ForceFront Storm Storefront E/T34000 Product Specifications

System (2 1/2" x 5")	Glass Size (max)	Frame Height (max)	Design Pressure (psf)	Missile Type	Interlayer Makeups Tested*	Texas Department of Insurance (TDI)	Florida Product Approval (FPA)	Florida Building Code HVHZ
E34000 Non Thermal (dry glazed)	48" x 120"	123 3/4"	+ 70 / - 61	Large (D)	1/4" HS - .090 Sentry Glas - 1/4" HS	CWFS-44	FL17192.1	Yes
E34000 Non Thermal (wet glazed)	48" x 120"	123 3/4"	+ 70 / - 68	Large (D)	1/4" HS - .090 Sentry Glas - 1/4" HS 1/4" HS - .077 Saflex CP - 1/4" HS	CWFS-44	FL17192.1	Yes
E34000 Non Thermal (dry glazed)	48" x 96"	99 3/4"	+ 50 / - 50	Large (D) Small (A)	1/4" HS - .090 Butacite PVB - 1/4" HS	CWFS-44	FL17192.1	Yes
T34000 Thermal (wet glazed)	48" x 120"	123 3/4"	+ 55 / - 55	Large (D)	1/4" HS - .090 Sentry Glas - 1/4" HS	CWFS-45	FL17192.2	Yes
T34000 Thermal (dry glazed)	48" x 120"	123 3/4"	+ 58 / - 55	Large (D)	1/4" HS - .090 Sentry Glas - 1/4" HS 1/4" HS - .077 Saflex CP - 1/4" HS	CWFS-45	FL17192.2	Yes
T34000 Thermal (wet glazed)	48" x 96"	99 3/4"	+ 50 / - 50	Large (D) Small (A)	1/4" HS - .090 Butacite PVB - 1/4" HS	CWFS-45	FL17192.2	Yes

The above table is for reference only. Refer to FPA or TDI installation instructions for approved frame sizes and configurations, design pressures, mullion types, reinforcement requirements, glass makeups, anchorage requirements, etc.

DISCLAIMER: Tubelite takes no responsibility for product selection or application, including but not limited to, compliance with building codes, safety codes, laws, merchantability or fitness for a particular purpose; and further disclaims all liability for the use, in whole or in part, of this Product Brochure in preparation of project specifications and/or other documents. Product Brochures are subject to change at any time, without notice, and at Tubelite's sole discretion. © 2016 Tubelite Inc.

041816



TUBELITE®
DEPENDABLE

LEADERS IN ECO-EFFICIENT STOREFRONT,
 CURTAINWALL AND ENTRANCE SYSTEMS



1-5/16" (31.96mm) Insulating Laminated VUE1-50

PERFORMANCE DATA

Transmittance	
Visible Light	46%
Solar Energy	18%
U-V*	<1%
Reflectance	
Visible Light-Exterior	11%
Visible Light-Interior	10%
Solar Energy	26%
NFRC U-Value	
Winter	0.29 Btu/(hr x sqft x °F)
Summer	0.25 Btu/(hr x sqft x °F)
Shading Coefficient (SC)	0.29
Relative Heat Gain	61 Btu/(hr x sqft)
Solar Heat Gain Coefficient (SHGC)	0.25
LSG	1.84

Makeup

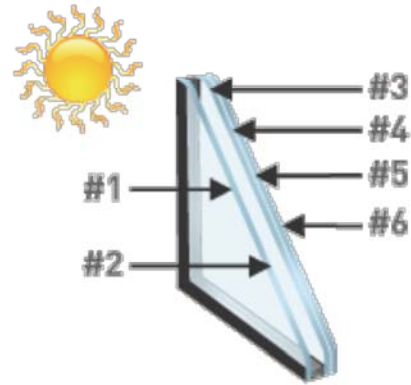

- 1/4" (6mm) clear VUE-50 #2
- 1/2" (13.2mm) airspace
- 1/4" (6mm) clear
- .060" (1.52mm) PVB
- 1/4" (6mm) clear

Product Comparison Chart

Color	Product Description - Performance Characteristics	Thickness (inches)	Visible Trans. (%)	Visible Refl. Out (%)	Visible Refl. In (%)	UV Trans. (%)	Solar Trans. (%)	Solar Refl. Out (%)	Winter U-factor	Summer U-factor	Shading Coeff.	Solar Heat Gain Coeff.	Relative Heat Gain	Light to Solar Gain
	19/32" Laminate - 1/4" Clear - 0.090" Clear PVB - 1/4" Clear	0.563	86	8	8	<1	64	6	0.92	0.84	0.84	0.73	181	1.18
	3/8" Laminate - 3/16" Clear - 0.030" Clear PVB - 3/16" Clear	0.424	87	9	9	<1	69	8	0.97	0.88	0.88	0.76	188	1.14
	1/4" Clear	0.223	89	9	9	66	77	7	1.02	0.93	0.94	0.82	201	1.09

NOTES: ACID ETCHED GLASS HAS SAME PERFORMANCE AS 1/4" CLEAR TEMP.

GlasSelect® calculates center of glass performance data using the Lawrence Berkeley National Laboratory (LBNL) Window 6.3 program (version 6.3.74.0) with Environmental Conditions set at NFRC 100-2010. Gas Library ID#1 (Air) is used for Insulating Glass units with air. Gas Library ID#9 (10% Air/90% Argon) is used for Insulating Glass units with argon. Monolithic glass data is from the following sources: 1. LBNL International Glazing Database (IGDB) version 44.0; 2. Vendor supplied spectral data files. Laminated glass data is from the following sources: 1. LBNL International Glazing Database (IGDB) version 44.0; 2. LBNL Optics 6 (version 6.0 Maintenance Pack 1); 3. Vendor supplied spectral data files; 4. Vendor supplied data. 5. Based on vendor testing, clear acid-etched glass performance data is estimated using regular clear glass of equivalent thickness.

Glass colors represented herein are included only for the general purpose of glass selection. Accurate representation of optical properties, including color and reflectivity, can only be achieved by viewing glass mock-ups in conditions that are similar to the actual job. User assumes all responsibility and liability for glass color selection. Thermal values are in Imperial units.



Date: May 17, 2016
 Customer: Star Glass
 Project:
 Location:
 Glass Type:

MONOLITHIC LAMINATED GLASS PERFORMANCE DATA

	<u>ID #</u>		<u>Notes</u>
Laminate:	1810	1/4" Clear Laminate	a
		Outer Ply: 1/8" Walker Textures® "Velour" #2	
		Interlayer: 0.030" Saflex® Clear PVB	
		Inner Ply: 1/8" Clear	
Nominal Thickness:	0.266 Inches		f

<u>Performance Properties</u>	<u>COG Results*</u>	<u>Units</u>
Transmittance		
Visible Light	88	%
Solar Energy	72	%
Ultraviolet	<1	%
Reflectance		
Visible Light (Exterior)	8	%
Visible Light (Interior)	8	%
Solar Energy (Exterior)	7	%
Thermal		
<i>Winter Nighttime</i>		
U-factor/U-Value	1.00	Btu/hr-ft ² -°F
<i>Summer Daytime</i>		
U-factor/U-Value	0.90	Btu/hr-ft ² -°F
Shading Coefficient	0.91	-
Solar Heat Gain Coefficient	0.79	-
Relative Heat Gain	194	Btu/hr-ft ²
Light to Solar Gain	1.11	-

***Vertically Glazed Center Of Glass (COG) Results Calculated Using LBNL Window 7.4 Software.**

- Notes:** a) NFRC certified spectral data file
 b) Data generated by Oldcastle BuildingEnvelope®
 c) Average solar data
 d) Simulated with LBNL Optics 6.0
 e) Vendor supplied spectral data file
 f) Please reference ASTM C1036 and C1172 for allowable glass thickness variations