



Air Conditioning & Heating

ARUF SERIES

*MULTI-POSITION
MULTI-SPEED PSC MOTOR*

AIR HANDLER

1½ TO 5 TONS



Contents

Nomenclature	2
Accessories	2
Product Specifications	3
Heater Kit Nomenclature	3
Dimensions	4
Airflow Data	5
Heat Kit Data	6
Wiring Diagrams	8

Product Features

- Check flowrator for cooling and heat pump applications
- Direct drive, multi-speed PSC blower motor
- All-aluminum evaporator coil
- Coil mounting track for quick repositioning
- Cabinet air leakage less than 2.0% at 1.0 inch H₂O when tested in accordance with ASHRAE standard 193
- Cabinet air leakage less than 1.4% at 0.5 inch H₂O when tested in accordance with ASHRAE standard 193
- 3 kW – 25 kW electric heater kits
- Horizontal or vertical configuration capabilities
- AHRI certified; ETL listed
- Rigid SmartFrame™ cabinet
- 21" depth for easier attic access
- DecaBDE-free thermoplastic drain pan with secondary drain connections
- Screw-less sides and back helps to reduce condensation when installed in humid locations
- Foil-faced insulation covers the internal casing to reduce cabinet condensation
- Galvanized, leather grain-embossed finish
- Glue-less cabinet insulation retention
- Tool-less filter access



* Complete warranty details available from your local dealer or at www.goodmanmfg.com. To receive the 10-Year Parts Limited Warranty, online registration must be completed within 60 days of installation. Online registration is not required in California or Québec.

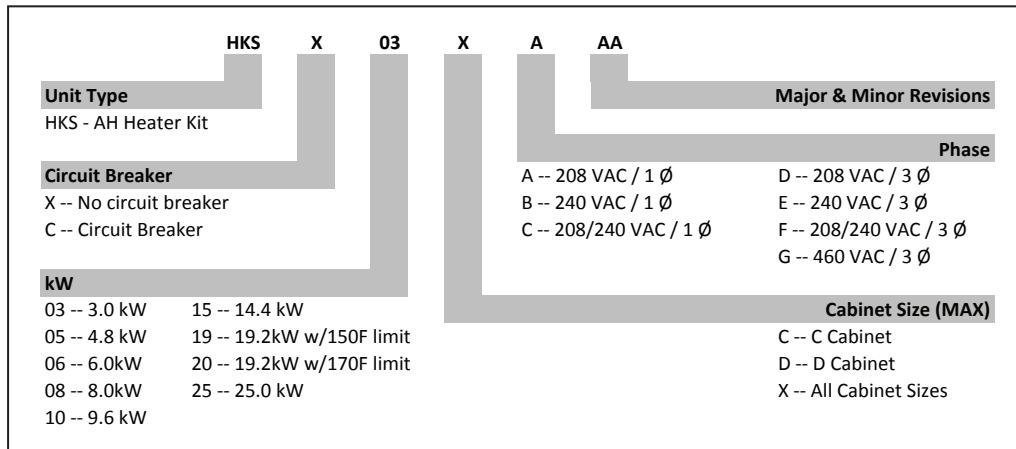
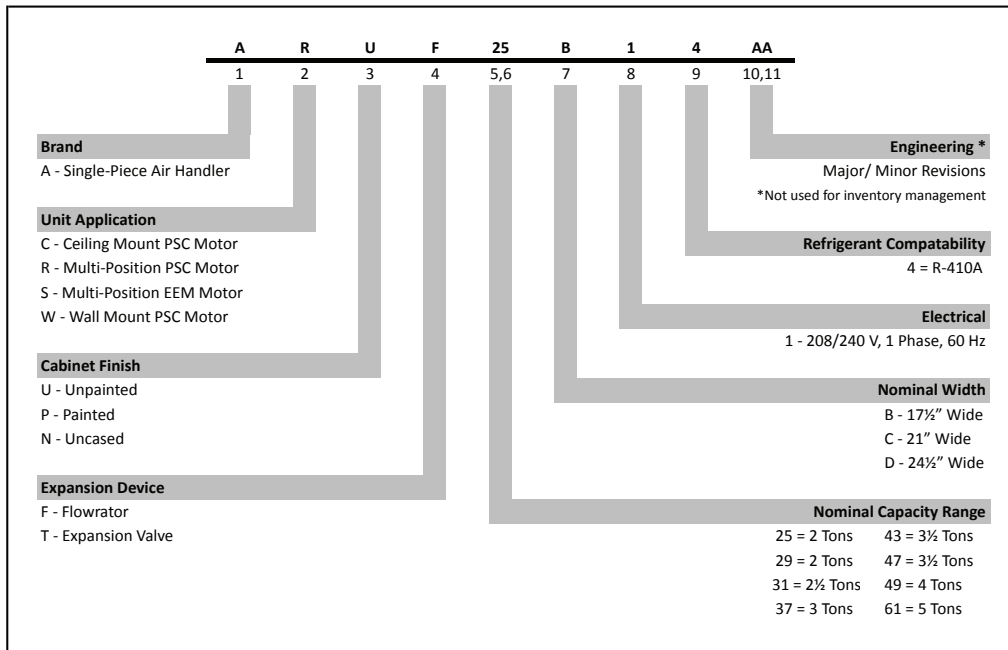

ACCESSORIES

EXPANSION VALVE KITS FOR AIR CONDITIONING AND HEAT PUMP APPLICATIONS

KIT NUMBER	DESCRIPTION	APPLICATION	REFRIGERANT	TONNAGE: OUTDOOR UNIT
TX2N4A	Non-bleed Valve	AC or HP	R-410A	1½ - 2 Ton
TX3N4	Non-bleed Valve	AC or HP	R-410A	2½ - 3 Ton
TX5N4	Non-bleed Valve	AC or HP	R-410A	3½ - 5 Ton

DOWNFLOW INSULATION KIT

DFK-B	DFK-C	DFK-D
ARUF25B14**	ARUF37C14**	ARUF37D14**
ARUF29B14**	ARUF43C14**	ARUF43D14**
ARUF31B14**	ARUF49C14**	ARUF47D14**
		ARUF49D14**
		ARUF61D14**

FILTERS

CHASSIS	PART #	SIZE
B	ALFH16201E	16.0" x 20.0"
C	ALFH1912201E	19.5" x 20.0"
D	ALFH20231E	23.0" x 20.0"

	ARUF 25B14*	ARUF 29B14*	ARUF 31B14*	ARUF 37C14*	ARUF 43C14*	ARUF 49C14*	ARUF 37D14*	ARUF 43D14*	ARUF 47D14*	ARUF 49D14*	ARUF 61D14*
NOMINAL RATINGS											
Cooling (Btu/h)	24,000	25,000	30,000	36,000	42,000	48,000	36,000	42,000	43,000	48,000	60,000
Piston Size	0.051	0.057	0.065	0.072	0.076	0.080	0.072	0.076	0.076	0.080	0.080
BLOWER											
Diameter	9½"	9½"	9½"	10⅝"	10⅝"	10⅝"	10⅝"	10⅝"	10⅝"	10⅝"	11 ¹⁵ / ₁₆ "
Width	6"	6"	6"	8"	8"	10⅝"	10⅝"	10⅝"	10⅝"	10⅝"	10⅝"
COIL CONNECTIONS											
Liquid	⅜"	⅜"	⅜"	⅜"	⅜"	⅜"	⅜"	⅜"	⅜"	⅜"	⅜"
Suction	¾"	¾"	⅞"	⅞"	⅞"	⅞"	⅞"	⅞"	⅞"	⅞"	⅞"
Coil Drain Connect (FPT)	¾"	¾"	¾"	¾"	¾"	¾"	¾"	¾"	¾"	¾"	¾"
ELECTRICAL DATA											
Voltage	208/230	208/230	208/230	208/230	208/230	208/230	208/230	208/230	208/230	208/230	208/230
Min Circuit Ampacity	2.4/2.4	2.4/2.4	2.4/2.4	4/4	4/4	4/4	4/4	4/4	4/4	4/4	6/6
Max. Overcurrent Device (Amps)	15/15	15/15	15/15	15/15	15/15	15/15	15/15	15/15	15/15	15/15	15/15
Minimum VAC	197	197	197	197	197	197	197	197	197	197	197
Maximum VAC	253	253	253	253	253	253	253	253	253	253	253
Blower Motor											
Full Load Amps (FLA)	1.9	1.9	1.9	3.0	3.0	3.1	3.0	3.5	3.5	3.5	4.6
Horsepower (HP)	⅓	⅓	⅓	⅓	⅓	½	⅓	½	½	½	¾
SHIP WEIGHT (LBS.)											
	100	100	110	130	130	135	140	145	150	145	155

Note: For a properly matched system and piston sizing information, refer to Amana piston kit chart of the corresponding Amana® outdoor unit.
 Minimum Circuit Ampacity (MCA) and Maximum Overcurrent Protection (MOP) for blower without supplemental heat installed.
 Refer to unit nameplate and/or Heat Kit Data for specification with approved accessory heaters installed.

HEATING kW CORRECTION FACTOR

SUPPLY VOLTAGE	240	230	220	210	208
CORRECTION FACTOR	1.00	0.92	0.84	0.77	0.75

Multiply the 240-volt heating capacity by correction factors.

DIMENSIONS

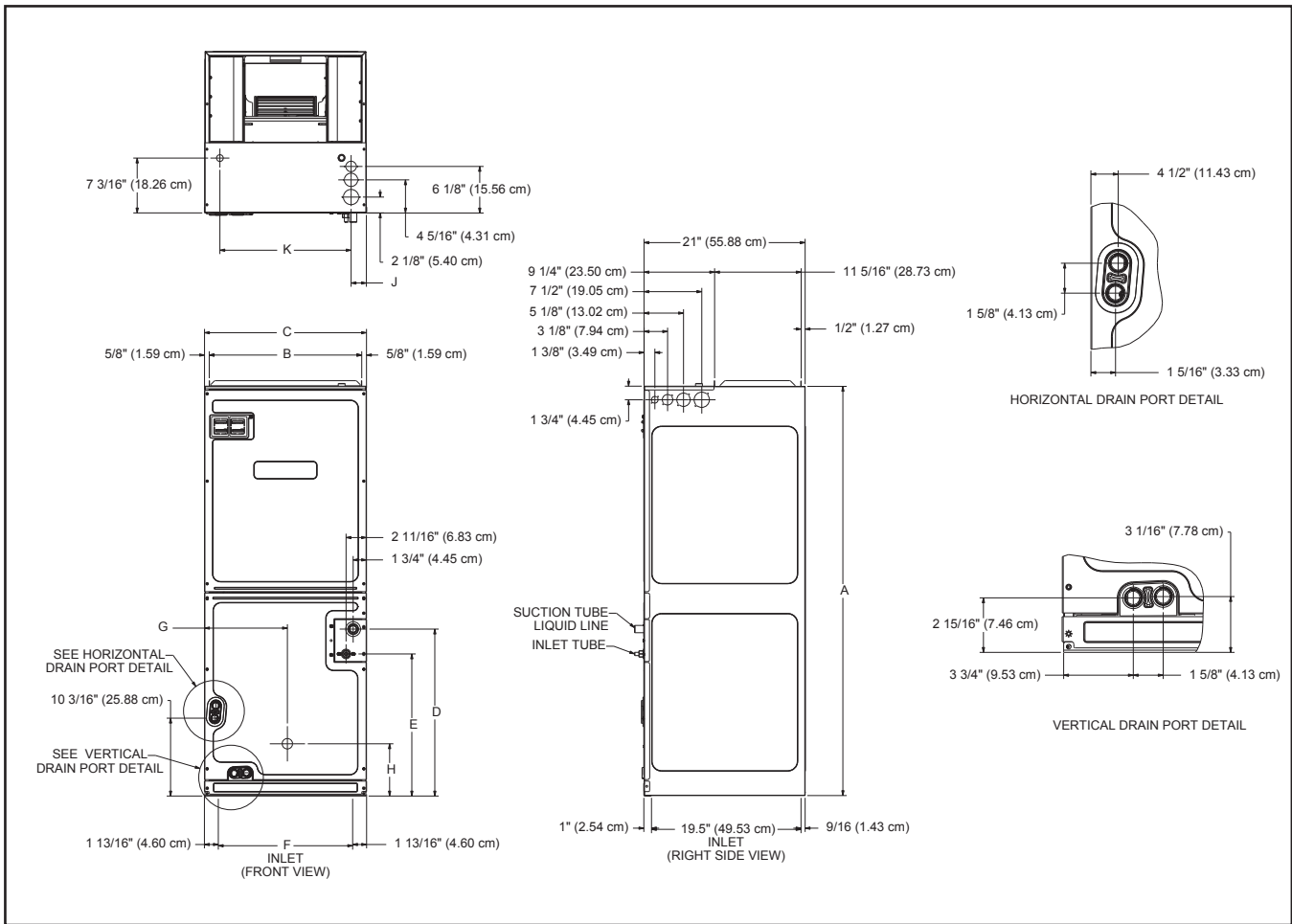

MODEL	A"	B"	C"	D"	E"	F"	G"	H"
ARUF25B14*	45	16 ³ / ₈	17 ¹ / ₂	15 ¹ / ₄	12	14 ³ / ₈	9 ³ / ₈	11 ³ / ₈
ARUF29B14*	45	16 ³ / ₈	17 ¹ / ₂	15 ¹ / ₄	12	14 ³ / ₈	9 ³ / ₈	12 ³ / ₄
ARUF31B14*	53 ⁷ / ₁₆	16 ³ / ₈	17 ¹ / ₂	23 ¹¹ / ₁₆	20 ¹ / ₂	14 ³ / ₈	9 ³ / ₈	7 ⁵ / ₈
ARUF37C14*	53 ⁷ / ₁₆	19 ³ / ₈	21	21 ¹³ / ₁₆	18 ⁵ / ₈	17 ¹¹ / ₁₆	10 ¹³ / ₁₆	6 ¹³ / ₁₆
ARUF43C14*	53 ⁷ / ₁₆	19 ³ / ₈	21	21 ¹³ / ₁₆	18 ⁵ / ₈	17 ¹¹ / ₁₆	10 ¹³ / ₁₆	6 ¹³ / ₁₆
ARUF49C14*	53 ⁷ / ₁₆	19 ³ / ₈	21	21 ¹³ / ₁₆	18 ⁵ / ₈	17 ¹¹ / ₁₆	10 ¹³ / ₁₆	6 ¹³ / ₁₆
ARUF37D14*	53 ⁷ / ₁₆	23 ⁵ / ₁₆	24 ¹ / ₂	21 ¹ / ₂	18 ⁵ / ₁₆	21 ³ / ₁₆	12 ⁵ / ₈	6 ⁷ / ₈
ARUF43D14*	53 ⁷ / ₁₆	23 ⁵ / ₁₆	24 ¹ / ₂	21 ¹ / ₂	18 ⁵ / ₁₆	21 ³ / ₁₆	12 ⁵ / ₈	6 ⁷ / ₈
ARUF47D14*	58	23 ⁵ / ₁₆	24 ¹ / ₂	26 ³ / ₈	22 ⁷ / ₈	21 ³ / ₁₆	12 ⁵ / ₈	25 ² / ₁₆
ARUF49D14*	53 ⁷ / ₁₆	23 ⁵ / ₁₆	24 ¹ / ₂	21 ¹ / ₂	18 ⁵ / ₁₆	21 ³ / ₁₆	12 ⁵ / ₈	6 ⁷ / ₈
ARUF61D14*	58	23 ⁵ / ₁₆	24 ¹ / ₂	26 ³ / ₈	22 ⁷ / ₈	21 ³ / ₁₆	12 ⁵ / ₈	25 ² / ₁₆

MODEL	MOTOR SPEED	STATIC PRESSURE (IN W.C) AIRFLOW (CFM)						
		0.1	0.2	0.3	0.4	0.5	0.6	0.7
ARUF25B14	LOW	650	620	595	540	490	420	275
	MED	885	865	825	815	750	690	560
	HIGH	1255	1225	1130	1090	965	925	800
ARUF29B14	LOW	650	620	595	540	490	420	275
	MED	885	865	825	815	750	690	560
	HIGH	1255	1225	1130	1090	965	925	800
ARUF31B14	LOW	660	625	595	560	500	430	330
	MED	930	905	865	820	765	700	590
	HIGH	1235	1185	1130	1060	990	910	825
ARUF37C14	LOW	1120	1085	1040	1000	940	875	800
	MED	1425	1385	1345	1285	1220	1145	1060
	HIGH	1625	1575	1520	1460	1375	1295	1200
ARUF43C14	LOW	1120	1085	1040	1000	940	875	800
	MED	1425	1385	1345	1285	1220	1145	1060
	HIGH	1625	1575	1520	1460	1375	1295	1200
ARUF49C14	LOW	1295	1255	1225	1175	1120	1055	970
	MED	1535	1485	1420	1370	1295	1215	1130
	HIGH	1755	1680	1590	1515	1425	1340	1250
ARUF37D14	LOW	1155	1115	1070	1015	955	895	840
	MED	1505	1470	1430	1375	1300	1210	1105
	HIGH	1785	1735	1680	1625	1555	1440	1330
ARUF43D14	LOW	1410	1360	1290	1210	1120	1010	920
	MED	1610	1540	1470	1390	1300	1190	1060
	HIGH	1900	1830	1740	1645	1540	1420	1280
ARUF47D14	LOW	1420	1370	1310	1240	1125	1045	960
	MED	1625	1585	1515	1435	1350	1235	1095
	HIGH	1930	1890	1820	1735	1635	1505	1355
ARUF49D14	LOW	1410	1360	1290	1210	1120	1010	920
	MED	1610	1540	1470	1390	1300	1190	1060
	HIGH	1900	1830	1740	1645	1540	1420	1280
ARUF61D14	LOW	1530	1500	1460	1405	1350	1280	1155
	MED	1950	1885	1830	1785	1745	1670	1595
	HIGH	2235	2170	2100	2030	1965	1915	1825

NOTES

- Airflow data indicated is at 230V without air filter in place.
- The chart is for information only. For satisfactory operation, external static pressure must not exceed value shown on rating plate. The shaded area indicates ranges in excess of maximum design external static pressure.
- Use the CFM adjustment factors of 0.98 for horizontal left and 0.96 for horizontal right & downflow orientations

MODEL & HEATER KIT	CIRCUIT 1			CIRCUIT 2			SINGLE-POINT KIT	
	HEATER	MCA ¹	MOP ²	HEATER AMPS	MCA ¹	MOP ²	MCA ¹	MOP ²
ARUF25B14AA	0/0	2.4/2.4	15/15	---	---	---	---	---
HKS*03XC*	10.8/12.5	16/18	20/20	---	---	---	---	---
HKS*05XC*	17.3/20	24/27	25/30	---	---	---	---	---
HKS*06XC*	21.7/25	29/34	30/35	---	---	---	---	---
HKS*08XC*	28.9/33.3	38/44	40/45	---	---	---	---	---
HKS*10XC*	34.7/40	46/52	50/60	---	---	---	---	---
ARUF29B14AA	0/0	2.4/2.4	15/15	---	---	---	---	---
HKS*03XC*	10.8/12.5	16/18	20/20	---	---	---	---	---
HKS*05XC*	17.3/20	24/27	25/30	---	---	---	---	---
HKS*06XC*	21.7/25	29/34	30/35	---	---	---	---	---
HKS*08XC*	28.9/33.3	38/44	40/45	---	---	---	---	---
HKS*10XC*	34.7/40	46/52	50/60	---	---	---	---	---
ARUF31B14AA	0/0	2.4/2.4	15/15	---	---	---	---	---
HKS*03XC*	10.8/12.5	16/18	20/20	---	---	---	---	---
HKS*05XC*	17.3/20	24/27	25/30	---	---	---	---	---
HKS*06XC*	21.7/25	29/34	30/35	---	---	---	---	---
HKS*08XC*	28.9/33.3	38/44	40/45	---	---	---	---	---
HKS*10XC*	34.7/40	46/52	50/60	---	---	---	---	---
HKSC15*##	34.7/40	46/53	50/60	17.3/20	22/25	25/25	67/77	70/80
ARUF37C14AA	0/0	4/4	15/15	---	---	---	---	---
HKS*03XC*	10.8/12.5	17/19	20/20	---	---	---	---	---
HKS*05XC*	17.3/20	25/29	30/30	---	---	---	---	---
HKS*06XC*	21.7/25	31/35	35/35	---	---	---	---	---
HKS*08XC*	28.9/33.3	40/45	40/50	---	---	---	---	---
HKS*10XC*	34.7/40	47/54	50/60	---	---	---	---	---
HKSC15*##	34.7/40	47/54	50/60	17.3/20	22/25	25/25	69/79	70/80
HKSC19C##	34.7/40	47/54	50/60	34.7/40	43/50	45/50	90/104	100/110
HKS*15XF*	0/0	4/4	15/15	30/34.6	38/43	40/45	---	---
HKS*20XF*	0/0	4/4	15/15	38/43	47/54	50/60	---	---
ARUF43C14AA	0/0	4/4	15/15	---	---	---	---	---
HKS*03XC*	10.8/12.5	17/19	20/20	---	---	---	---	---
HKS*05XC*	17.3/20	25/29	30/30	---	---	---	---	---
HKS*06XC*	21.7/25	31/35	35/35	---	---	---	---	---
HKS*08XC*	28.9/33.3	40/45	40/50	---	---	---	---	---
HKS*10XC*	34.7/40	47/54	50/60	---	---	---	---	---
HKSC15*##	34.7/40	47/54	50/60	17.3/20	22/25	25/25	69/79	70/80
HKSC19C##	34.7/40	47/54	50/60	34.7/40	43/50	45/50	90/104	100/110
HKS*15XF*	0/0	4/4	15/15	30/34.6	38/43	40/45	---	---
HKS*20XF*	0/0	4/4	15/15	38/43	47/54	50/60	---	---
ARUF49C14AA	0/0	4/4	15/15	---	---	---	---	---
HKS*03XC*	10.8/12.5	17/20	20/20	---	---	---	---	---
HKS*05XC*	17.3/20	26/29	30/30	---	---	---	---	---
HKS*06XC*	21.7/25	31/35	35/40	---	---	---	---	---
HKS*08XC*	28.9/33.3	40/46	45/50	---	---	---	---	---
HKS*10XC*	34.7/40	47/54	50/60	---	---	---	---	---
HKSC15*##	34.7/40	47/54	50/60	17.3/20	22/25	25/25	69/79	70/80
HKSC19C##	34.7/40	47/54	50/60	34.7/40	43/50	45/50	91/104	100/110
HKS*15XF*	0/0	4/4	15/15	30/34.6	38/43	40/45	---	---
HKS*20XF*	0/0	4/4	15/15	38/43	47/54	50/60	---	---

¹ Minimum Circuit Ampacity (Heater Amps + Motor Amps) X 1.25

² Maximum Overcurrent Protection = 2.25 X Motor Amps + Heater Amps

* Revision level that may or may not be designated

C = Circuit Breaker Option

CA indicates 208V and CB indicates 240V

--- indicates Not Required

MODEL & HEATER KIT	CIRCUIT 1			CIRCUIT 2			SINGLE-POINT KIT	
	HEATER	MCA ¹	MOP ²	HEATER AMPS	MCA ¹	MOP ²	MCA ¹	MOP ²
ARUF37D14AA	0/0	4/4	15/15	---	---	---	---	---
HKS*03XC*	10.8/12.5	17/19	20/20	---	---	---	---	---
HKS*05XC*	17.3/20	25/29	30/30	---	---	---	---	---
HKS*06XC*	21.7/25	31/35	35/35	---	---	---	---	---
HKS*08XC*	28.9/33.3	40/45.4	40/50	---	---	---	---	---
HKS*10XC*	34.7/40	47/54	50/60	---	---	---	---	---
HKSC15*##	34.7/40	47/54	50/60	17.3/20	22/25	25/25	69/79	70/80
HKSC20D##	34.7/40	47/54	50/60	34.7/40	44/50	45/50	90/104	100/110
HKS*15XF*	0/0	4/4	15/15	30/34.6	38/43	40/45	---	---
HKS*20XF*	0/0	4/4	15/15	38/43	47/54	50/60	---	---
ARUF43D14AA	0/0	4/4	15/15	---	---	---	---	---
HKS*03XC*	10.8/12.5	18/20	20/20	---	---	---	---	---
HKS*05XC*	17.3/20	26/29	30/30	---	---	---	---	---
HKS*06XC*	21.7/25	31/36	35/40	---	---	---	---	---
HKS*08XC*	28.9/33.3	40/46	45/50	---	---	---	---	---
HKS*10XC*	34.7/40	48/54	50/60	---	---	---	---	---
HKSC15*##	34.7/40	48/54	50/60	17.3/20	22/25	25/25	69/79	70/80
HKSC20D##	34.7/40	48/54	50/60	34.7/40	43/50	45/50	91/104	100/110
HKS*15XF*	0/0	4/4	15/15	30/34.6	38/43	40/45	---	---
HKS*20XF*	0/0	4/4	15/15	38/43	47/54	50/60	---	---
ARUF49D14AA	0/0	4/4	15/15	---	---	---	---	---
HKS*03XC*	10.8/12.5	18/20	20/20	---	---	---	---	---
HKS*05XC*	17.3/20	26/29	30/30	---	---	---	---	---
HKS*06XC*	21.7/25	31/36	35/40	---	---	---	---	---
HKS*08XC*	28.9/33.3	40/46	45/50	---	---	---	---	---
HKS*10XC*	34.7/40	48/54	50/60	---	---	---	---	---
HKSC15*##	34.7/40	48/54	50/60	17.3/20	22/25	25/25	69/79	70/80
HKSC20D##	34.7/40	48/54	50/60	34.7/40	43/50	45/50	91/104	100/110
HKS*15XF*	0/0	4/4	15/15	30/34.6	38/43	40/45	---	---
HKS*20XF*	0/0	4/4	15/15	38/43	47/54	50/60	---	---
ARUF47D14AA	0/0	4/4	15/15	---	---	---	---	---
HKS*03XC*	10.8/12.5	18/20	20/20	---	---	---	---	---
HKS*05XC*	17.3/20	26/29	30/30	---	---	---	---	---
HKS*06XC*	21.7/25	31/36	35/40	---	---	---	---	---
HKS*08XC*	28.9/33.3	40/46	45/50	---	---	---	---	---
HKS*10XC*	34.7/40	48/54	50/60	---	---	---	---	---
HKSC15*##	34.7/40	48/54	50/60	17.3/20	22/25	25/25	69/79	70/80
HKSC20D##	34.7/40	48/54	50/60	34.7/40	44/50	45/50	91/104	100/110
HKS*15XF*	0/0	4/4	15/15	30/34.6	38/43	40/45	---	---
HKS*20XF*	0/0	4/4	15/15	38/43	47/54	50/60	---	---
ARUF61D14AA	0/0	6/6	15/15	---	---	---	---	---
HKS*03XC*	10.8/12.5	19/21	20/25	---	---	---	---	---
HKS*05XC*	17.3/20	27/31	30/35	---	---	---	---	---
HKS*06XC*	21.7/25	33/37	35/40	---	---	---	---	---
HKS*08XC*	28.9/33.3	42/47	45/50	---	---	---	---	---
HKS*10XC*	34.7/40	49/56	50/60	---	---	---	---	---
HKSC15*##	34.7/40	49/56	50/60	17.3/20	22/25	25/25	71/81	80/90
HKSC20D##	34.7/40	49/56	50/60	34.7/40	43/50	45/50	92/106	100/110
HKS*15XF*	0/0	6/6	15/15	30/34.6	38/43	40/45	---	---
HKS*20XF*	0/0	6/6	15/15	38/43	47/54	50/60	---	---
HKSC25DC*	52/60	71/81	80/90	35/40	43/50	45/50	114/131	125/150

¹ Minimum Circuit Ampacity (Heater Amps + Motor Amps) X 1.25² Maximum Overcurrent Protection = 2.25 X Motor Amps + Heater Amps

* Revision level that may or may not be designated

C = Circuit Breaker Option

CA indicates 208V and CB indicates 240V

--- indicates Not Required

WIRING DIAGRAM – AIR HANDLER

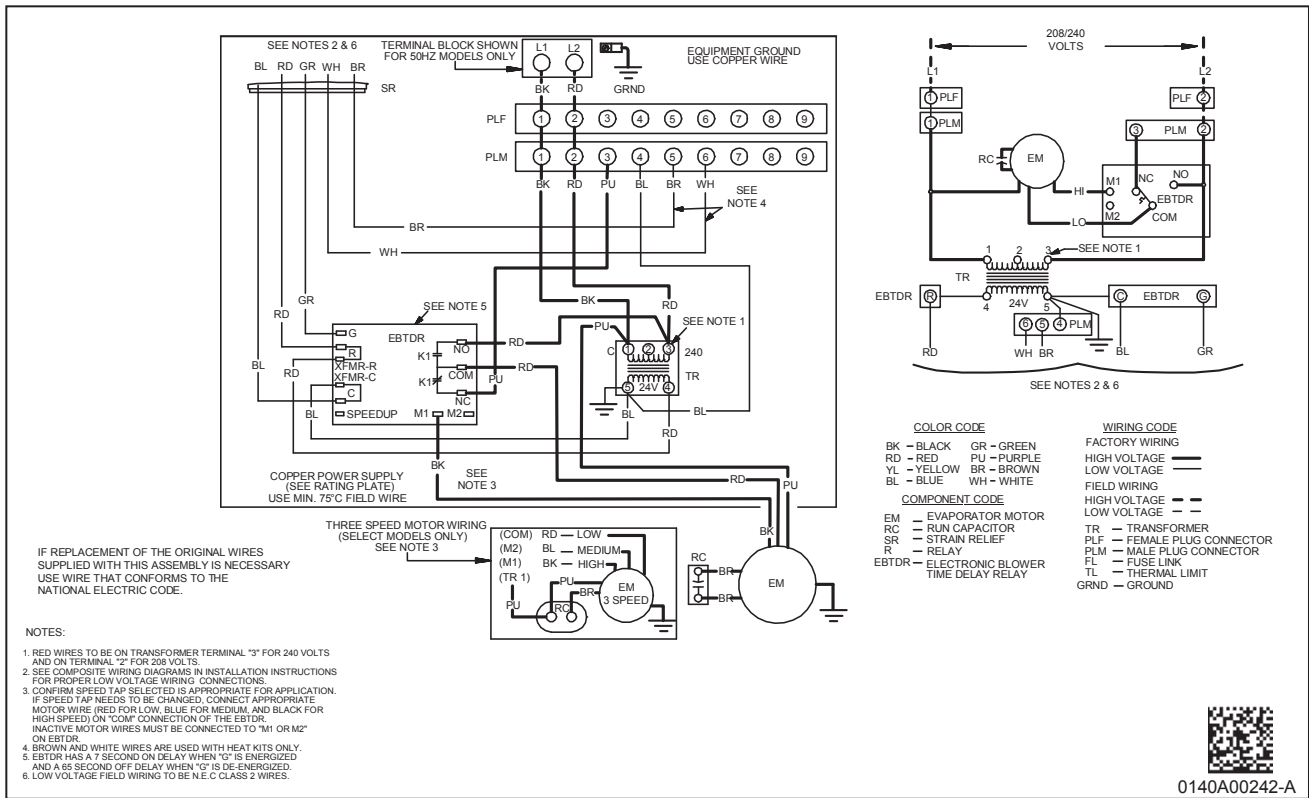

WIRING DIAGRAM – 3 PHASE HEATER KIT

NOTE: WHEN INSTALLING HEATER KIT, ENSURE SPEED TAP MUST EXCEED OR EQUAL THE MINIMUM BLOWER SPEED (MBS) SPECIFIED FOR THE AIRHANDLER/HEATER KIT COMBINATION ON THIS UNIT'S SERIAL PLATE. AFTER INSTALLING OPTIONAL HEAT KIT, MARK AN "X" IN THE PROVIDED BELOW. NO MARK INDICATES NO HEAT KIT INSTALLED.

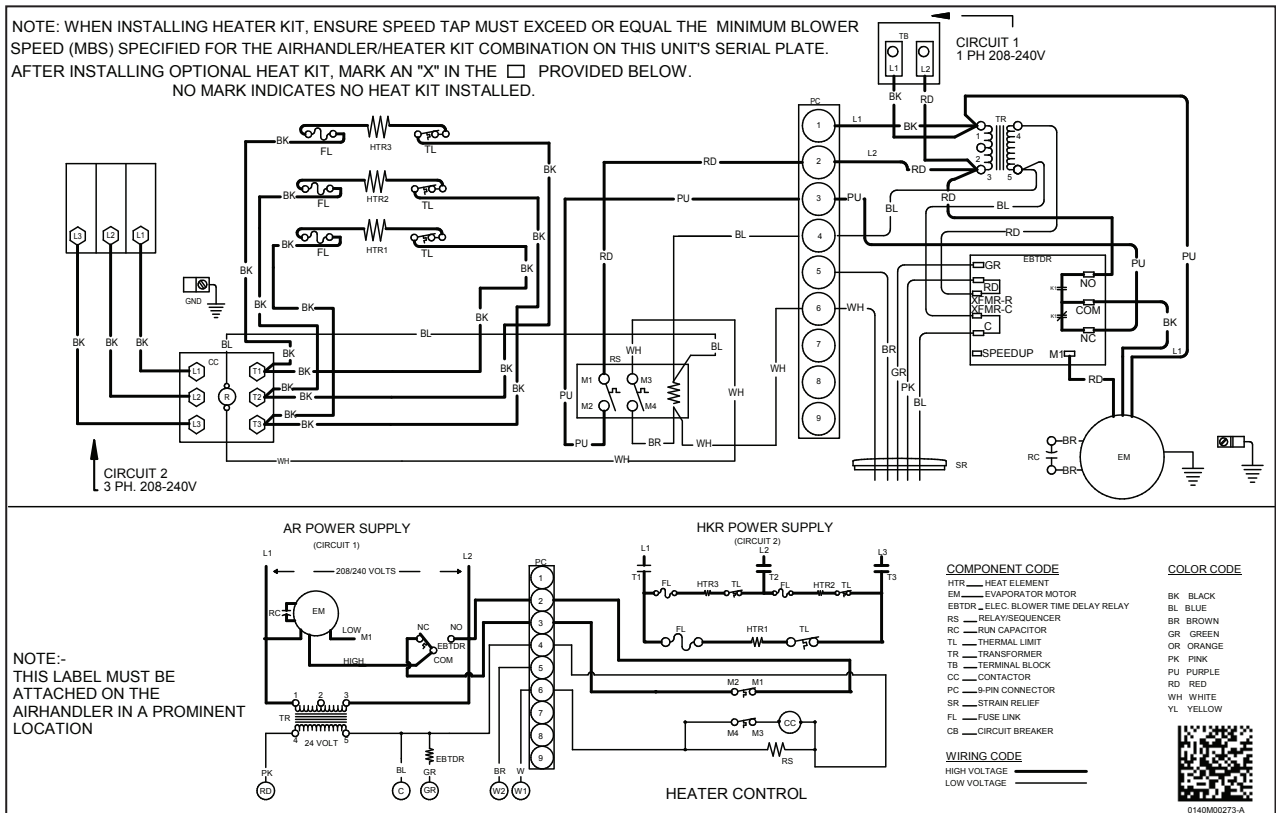

Wiring is subject to change. Always refer to the wiring diagram on the unit for the most up-to-date wiring.



High Voltage: Disconnect all power before servicing or installing this unit. Multiple power sources may be present. Failure to do so may cause property damage, personal injury, or death.



Goodman Manufacturing Company, L.P., reserves the right to discontinue, or change at any time, specifications or designs without notice or without incurring obligations. © 2015 Goodman Manufacturing Company, L.P. • Houston, Texas • Printed in the USA.