



VSX14

SPLIT SYSTEM AIR CONDITIONER

COOLING CAPACITY: 18,000 - 60,000 BTU/H

UP TO 14 SEER & 12.5 EER



Contents

Nomenclature.....	2
Product Specifications.....	3
Expanded Cooling Data	5
Performance Data	29
AHRI Ratings	31
Dimensions	70
Wiring Diagrams.....	71
Accessories	72

Standard Features

- Energy-efficient compressor
- Quiet condenser fan system
- Factory-installed liquid line filter drier
- Copper tube/aluminum fin coil
- Brass liquid and suction service valves with sweat connections
- Ground lug connection
- AHRI Certified; ETL Listed

Cabinet Features

- Sound control top designed for quiet operation
- Steel louver coil guard
- Heavy-gauge galvanized-steel cabinet
- Attractive Bahama Beige powder-paint finish with 500-hour salt-spray approval
- When properly anchored, meets the 2010 Florida Building Code unit integrity requirements for hurricane-type winds (Anchor bracket kits available.)



* Complete warranty details available from your local dealer or at www.goodmanmfg.com/gmc. To receive the 10-Year Parts Limited Warranty, online registration must be completed within 60 days of installation. Registration is not required in California or Quebec.

	V	S	X	14	036	1	A	A
	1	2	3	4,5	6,7,8	9	10	11
Brand	V Standard Feature Set						Engineering Major & Minor Revisions (not used for inventory or ordering)	
Product Category	S Split System						Electrical	
Unit Type	X Condenser R-410A Z Heat Pump R-410A						1 208/230 V, 1 Phase, 60 Hz 2 220/240 V, 1 Phase, 50 Hz 3 208/230 V, 3 Phase, 60 Hz	
Efficiency	13 13 SEER 16 16 SEER 14 14 SEER 18 18 SEER						Nominal Capacity	
					018 1½ Tons	030 2½ Tons	042 3½ Tons	
					019 1½ Tons	031 2½ Tons	043 3½ Tons	
					024 2 Tons	036 3 Tons	048 4 Tons	
					025 2 Tons	037 3 Tons	060 5 Tons	

	VSX14 0181A*	VSX14 0191A*	VSX14 0241A*	VSX14 0251A*	VSX14 0301A*	VSX14 0311A*
CAPACITIES						
Nominal Cooling (BTU/h)	18,000	18,000	24,000	24,000	30,000	30,000
SEER / EER	14 / 12	14 / 12.2	14 / 12	14 / 12.2	14 / 12	14 / 12.2
Decibels	71	71	71	71	72	72
COMPRESSOR						
RLA	9.0	9.0	10.9	10.9	12.8	12.8
LRA	48	47.5	62.9	62.9	64	67.8
CONDENSER FAN MOTOR						
Horsepower	1/8	1/8	1/12	1/8	1/6	1/6
FLA	0.7	0.7	0.6	0.7	1.1	1.1
REFRIGERATION SYSTEM						
Refrigerant Line Size ¹						
Liquid Line Size ("O.D.)	3/8"	3/8"	3/8"	3/8"	3/8"	3/8"
Suction Line Size ("O.D.)	3/4"	3/4"	3/4"	3/4"	3/4"	3/4"
Refrigerant Connection Size						
Liquid Valve Size ("O.D.)	3/8"	3/8"	3/8"	3/8"	3/8"	3/8"
Suction Valve Size ("O.D.) ^{4 5}	3/4"	3/4"	3/4"	3/4"	3/4"	3/4"
Valve Type	Sweat	Sweat	Sweat	Sweat	Sweat	Sweat
Refrigerant Charge	68	68	70	70	80	90
Shipped with Orifice Size	0.052	0.053	0.057	0.057	0.065	0.063
ELECTRICAL DATA						
Voltage-Phase (60 Hz)	208/230-1	208/230-1	208/230-1	208/230-1	208/230-1	208/230-1
Minimum Circuit Ampacity ²	12	12	14.2	14.3	17.1	17.1
Max. Overcurrent Protection ³	20 amps	20 amps	25 amps	25 amps	25 amps	25 amps
Min / Max Volts	197/253	197/253	197/253	197/253	197/253	197/253
Electrical Conduit Size	1/2" or 3/4"	1/2" or 3/4"	1/2" or 3/4"	1/2" or 3/4"	1/2" or 3/4"	1/2" or 3/4"
EQUIPMENT WEIGHT (LBS)						
	131	131	131	131	162	162
SHIP WEIGHT (LBS)						
	146	146	146	146	180	180

¹ Line sizes denoted for 25' line sets, tested and rated in accordance with AHRI Standard 210/240. For other line-set lengths or sizes, refer to the installation & Operating instructions and/or the long line-set guidelines.

² Wire size should be determined in accordance with National Electrical Codes; extensive wire runs will require larger wire sizes

³ Must use time-delay fuses or HACR-type circuit breakers of the same size as noted.

⁴ Installer will need to supply 3/8" to 3/4" adapters for suction line connections.

⁵ Installer will need to supply 3/8" to 1/2" adapters for suction line connections.

NOTES

- Always check the S&R plate for electrical data on the unit being installed.
- Unit is charged with refrigerant for 15' of 3/8" liquid line. System charge must be adjusted per Installation Instructions Final Charge Procedure.

	VSX14 0361A*	VSX14 0371A*	VSX14 0421A*	VSX14 0431A*	VSX14 0481A*	VSX14 0601A*
CAPACITIES						
Nominal Cooling (BTU/h)	36,000	36,000	42,000	42,000	48,000	60,000
SEER / EER	14 / 12	14 / 12.2	14 / 12	14 / 12.2	14 / 11.7	14 / 11.7
Decibels	73	73	73	73	74	75
COMPRESSOR						
RLA	14.1	14.1	16.7	16.7	19.9	25.0
LRA	77	72.2	79	79	109	134
CONDENSER FAN MOTOR						
Horsepower	1/6	1/6	1/6	1/6	1/4	1/4
FLA	1.1	1.1	1.1	1.1	1.5	1.5
REFRIGERATION SYSTEM						
Refrigerant Line Size ¹						
Liquid Line Size ("O.D.)	3/8"	3/8"	3/8"	3/8"	3/8"	3/8"
Suction Line Size ("O.D.)	7/8"	7/8"	1 1/8"	1 1/8"	1 1/8"	1 1/8"
Refrigerant Connection Size						
Liquid Valve Size ("O.D.)	3/8"	3/8"	3/8"	3/8"	3/8"	3/8"
Suction Valve Size ("O.D.) ^{4 5}	3/4" ⁴	3/4" ⁴	7/8" ⁵	7/8"	7/8" ⁵	7/8" ⁵
Valve Type	Sweat	Sweat	Sweat	Sweat	Sweat	Sweat
Refrigerant Charge	80	89	112	112	131	125
Shipped with Orifice Size	0.068	0.071	0.074	0.074	0.078	0.088
ELECTRICAL DATA						
Voltage-Phase (60 Hz)	208/230-1	208/230-1	208/230-1	208/230-1	208/230-1	208/230-1
Minimum Circuit Ampacity ²	18.7	18.7	22	22	26.4	32.8
Max. Overcurrent Protection ³	30 amps	30 amps	35 amps	35 amps	45 amps	50 amps
Min / Max Volts	197/253	197/253	197/253	197/253	197/253	197/253
Electrical Conduit Size	1/2" or 3/4"	1/2" or 3/4"	1/2" or 3/4"	1/2" or 3/4"	1/2" or 3/4"	1/2" or 3/4"
EQUIPMENT WEIGHT (LBS)						
	162	162	189	189	220	260
SHIP WEIGHT (LBS)						
	180	180	207	207	242	280

¹ Line sizes denoted for 25' line sets, tested and rated in accordance with AHRI Standard 210/240. For other line-set lengths or sizes, refer to the installation & Operating instructions and/or the long line-set guidelines.

² Wire size should be determined in accordance with National Electrical Codes; extensive wire runs will require larger wire sizes

³ Must use time-delay fuses or HACR-type circuit breakers of the same size as noted.

⁴ Installer will need to supply 3/4" to 7/8" adapters for suction line connections.

⁵ Installer will need to supply 7/8" to 1 1/8" adapters for suction line connections.

NOTES

- Always check the S&R plate for electrical data on the unit being installed.
- Unit is charged with refrigerant for 15' of 3/8" liquid line. System charge must be adjusted per Installation Instructions Final Charge Procedure.

IDB		OUTDOOR AMBIENT TEMPERATURE												105												115																					
		65						75						85						95						105						115															
		ENTERING INDOOR WET BULB TEMPERATURE												ENTERING INDOOR WET BULB TEMPERATURE												ENTERING INDOOR WET BULB TEMPERATURE												ENTERING INDOOR WET BULB TEMPERATURE									
AIRFLOW	59	63	67	71	59	63	67	71	59	63	67	71	59	63	67	71	59	63	67	71	59	63	67	71	59	63	67	71	59	63	67	71															
525	MBh	18.3	18.6	19.1	-	18.1	18.4	19.0	-	17.7	17.9	18.5	-	16.8	17.1	17.7	-	15.8	16.1	16.6	-	14.9	15.2	15.7	-	14.9	15.2	15.7	-																		
	S/T	0.57	0.50	0.37	-	0.58	0.51	0.38	-	0.60	0.53	0.40	-	0.62	0.55	0.42	-	1.00	0.57	0.44	-	1.00	0.62	0.49	-	1.00	0.62	0.49	-																		
	ΔT	20	18	15	-	20	18	15	-	20	19	15	-	20	18	15	-	21	18	15	-	21	19	16	-	21	19	16	-																		
	KW	1.09	1.09	1.09	-	1.22	1.22	1.21	-	1.36	1.36	1.35	-	1.51	1.51	1.50	-	1.68	1.68	1.67	-	1.87	1.87	1.87	-	1.87	1.87	1.87	-																		
	Amps	4.0	4.0	4.0	-	4.6	4.6	4.6	-	5.2	5.2	5.2	-	5.9	5.9	5.9	-	6.7	6.7	6.7	-	7.6	7.6	7.6	-	7.6	7.6	7.6	-																		
HI PR	243	244	246	-	282	283	284	-	322	323	325	-	365	366	368	-	412	413	415	-	462	463	464	-	462	463	464	-																			
LO PR	122	123	126	-	129	131	134	-	136	137	140	-	141	143	146	-	147	148	151	-	153	155	158	-	153	155	158	-																			
600	MBh	18.6	18.8	19.4	-	18.4	18.6	19.2	-	17.9	18.2	18.7	-	17.1	17.3	17.9	-	16.1	16.3	16.9	-	15.2	15.4	16.0	-	15.2	15.4	16.0	-																		
	S/T	0.63	0.56	0.43	-	0.64	0.57	0.44	-	0.66	0.59	0.46	-	0.68	0.61	0.48	-	1.00	0.63	0.50	-	1.00	0.68	0.55	-	1.00	0.68	0.55	-																		
	ΔT	19	17	14	-	19	17	14	-	19	17	14	-	19	17	14	-	19	17	13	-	20	18	15	-	20	18	15	-																		
	KW	1.10	1.10	1.10	-	1.22	1.22	1.22	-	1.36	1.36	1.36	-	1.51	1.51	1.51	-	1.68	1.68	1.68	-	1.88	1.88	1.88	-	1.88	1.88	1.88	-																		
	Amps	4.0	4.0	4.0	-	4.6	4.6	4.6	-	5.2	5.2	5.2	-	5.9	5.9	5.9	-	6.7	6.7	6.7	-	7.6	7.6	7.6	-	7.6	7.6	7.6	-																		
HI PR	245	246	248	-	284	285	286	-	324	325	327	-	367	368	370	-	414	415	417	-	464	465	466	-	464	465	466	-																			
LO PR	115	119	129	-	118	122	133	-	122	126	138	-	126	130	141	-	128	132	144	-	131	135	148	-	131	135	148	-																			
675	MBh	18.8	19.1	19.6	-	18.7	18.9	19.5	-	18.2	18.5	19.0	-	17.4	17.6	18.2	-	16.4	16.6	17.2	-	15.5	15.7	16.3	-	15.5	15.7	16.3	-																		
	S/T	0.66	0.59	0.46	-	0.67	0.60	0.47	-	0.69	0.62	0.49	-	1.00	0.64	0.51	-	1.00	0.66	0.53	-	1.00	0.71	0.58	-	1.00	0.71	0.58	-																		
	ΔT	18	16	13	-	18	16	13	-	18	16	13	-	18	16	13	-	18	16	12	-	19	17	14	-	19	17	14	-																		
	KW	1.10	1.10	1.10	-	1.23	1.23	1.23	-	1.37	1.37	1.37	-	1.52	1.52	1.52	-	1.69	1.69	1.69	-	1.89	1.89	1.88	-	1.89	1.89	1.88	-																		
	Amps	4.1	4.0	4.0	-	4.6	4.6	4.6	-	5.3	5.3	5.2	-	6.0	5.9	5.9	-	6.7	6.7	6.7	-	7.6	7.6	7.6	-	7.6	7.6	7.6	-																		
HI PR	247	248	250	-	286	287	288	-	326	327	329	-	369	370	372	-	416	417	419	-	466	467	468	-	466	467	468	-																			
LO PR	126	127	130	-	133	134	138	-	139	141	144	-	145	146	150	-	150	152	155	-	157	159	162	-	157	159	162	-																			
525	MBh	18.3	18.6	19.1	20.0	18.2	18.4	19.0	19.8	17.7	17.9	18.5	19.3	16.9	17.1	17.7	18.5	15.9	16.1	16.7	17.5	14.9	15.2	15.7	16.6	14.9	15.2	15.7	16.6																		
	S/T	0.70	0.62	0.50	0.36	0.70	0.63	0.50	0.37	1.00	0.65	0.53	0.39	1.00	0.67	0.54	0.41	1.00	0.69	0.57	0.43	1.00	1.00	0.61	0.48	1.00	1.00	0.61	0.48																		
	ΔT	24	22	19	15	24	22	19	15	25	23	19	16	24	22	18	14	23	24	22	19	15	25	23	20	25	23	20	16																		
	KW	1.09	1.09	1.09	1.10	1.22	1.22	1.21	1.22	1.36	1.36	1.35	1.36	1.51	1.51	1.50	1.51	1.68	1.68	1.67	1.68	1.87	1.87	1.87	1.88	1.87	1.87	1.87	1.88																		
	Amps	4.0	4.0	4.0	4.0	4.6	4.6	4.6	4.6	5.2	5.2	5.2	5.2	5.9	5.9	5.9	5.9	6.7	6.7	6.7	6.7	7.6	7.6	7.6	7.6	7.6	7.6	7.6	7.6																		
HI PR	243	244	246	250	282	283	285	289	322	323	325	329	365	366	368	372	412	412	413	415	419	462	463	465	469	462	463	465	469																		
LO PR	122	123	126	132	129	131	134	139	136	137	140	145	141	143	146	151	156	147	148	151	156	153	155	158	163	153	155	158	163																		
600	MBh	18.6	18.8	19.4	20.2	18.4	18.7	19.2	20.0	17.9	18.2	18.7	19.6	17.1	17.4	17.9	18.7	16.1	16.4	16.9	17.7	15.2	15.4	16.0	16.8	15.2	15.4	16.0	16.8																		
	S/T	0.75	0.68	0.55	0.42	0.76	0.69	0.56	0.42	1.00	0.71	0.58	0.45	1.00	0.73	0.60	0.47	1.00	0.75	0.62	0.49	1.00	1.00	0.67	0.54	1.00	1.00	0.67	0.54																		
	ΔT	23	21	18	14	23	21	18	14	23	22	18	14	23	21	18	14	23	23	21	18	14	24	22	19	24	22	19	15																		
	KW	1.10	1.10	1.10	1.10	1.22	1.22	1.22	1.23	1.36	1.36	1.36	1.37	1.51	1.51	1.51	1.52	1.68	1.68	1.68	1.69	1.88	1.88	1.88	1.89	1.88	1.88	1.88	1.89																		
	Amps	4.0	4.0	4.0	4.1	4.6	4.6	4.6	4.6	5.2	5.2	5.2	5.3	5.9	5.9	5.9	6.0	6.7	6.7	6.7	6.7	7.6	7.6	7.6	7.6	7.6	7.6	7.6	7.6																		
HI PR	246	247	248	253	284	285	287	291	324	325	327	331	367	368	370	374	414	414	415	417	421	464	465	467	471	464	465	467	471																		
LO PR	124	125	128	133	131	132	136	141	137	139	142	147	143	144	148	153	158	148	150	153	158	155	157	160	165	155	157	160	165																		
675	MBh	18.9	19.1	19.7	20.5	18.7	18.9	19.5	20.3	18.2	18.5	19.0	19.9	17.4	17.6	18.2	19.0	16.4	16.6	17.2	18.0	15.5	15.7	16.3	17.1	15.5	15.7	16.3	17.1																		
	S/T	0.79	0.71	0.59	0.45	0.79	0.72	0.59	0.46	1.00	0.74	0.62	0.48	1.00	0.76	0.63	0.50	1.00	0.78	0.65	0.52	1.00	1.00	0.70	0.57	1.00	1.00	0.70	0.57																		
	ΔT	22	20	17	13	22	20	17	13	23	21	17	14	22	20	17	13	22	22	20	17	13	23	21	18	23	21	18	14																		
	KW	1.10	1.10	1.10	1.11	1.23	1.23	1.23	1.24	1.37	1.37	1.37	1.37	1.52	1.52	1.52	1.53	1.69	1.69	1.69	1.69	1.89	1.88	1.88	1.89	1.89	1.88	1.88	1.89																		
	Amps	4.0	4.0	4.0	4.1	4.6	4.6	4.6	4.7	5.3	5.3	5.2	5.3	6.0	5.9	5.9	6.0	6.7	6.7	6.7	6.7	7.6	7.6	7.6	7.7	7.6	7.6	7.6	7.7																		
HI PR	248	249	250	255	286	287	289	293	326	327	329	333	369	370	372	376	416	416	417	419	423	466	467	469	473	466	467	469	473																		
LO PR	126	127	130	135	133	134	138	143	139	141	144	149	145	146	150	155	160	150	152	155	160	157	159	162	167	157	159	162	167																		

IDB: Entering Indoor Dry Bulb Temperature
 High and low pressures are measured at the liquid and suction service valves.
 Shaded area reflects ACCA (TVA) conditions
 KW = Total system power
 Amps = outdoor unit amps (comp.+fan)

IDB	AIRFLOW	OUTDOOR AMBIENT TEMPERATURE												ENTERING INDOOR WET BULB TEMPERATURE											
		65				75				85				95				105				115			
		59	63	67	71	59	63	67	71	59	63	67	71	59	63	67	71	59	63	67	71	59	63	67	71
80	MBh	18.4	18.7	19.2	20.1	18.3	18.5	19.1	19.9	17.8	18.0	18.6	19.4	17.0	17.2	17.8	18.6	15.9	16.2	16.8	17.6	15.0	15.3	15.8	16.7
	S/T	0.82	0.74	0.62	0.5	1.00	0.75	0.62	0.49	1.00	0.77	0.64	0.5	1.00	0.79	0.66	0.53	1.00	1.00	0.68	0.6	1.00	1.00	0.73	0.60
	ΔT	28	27	23	19	28	27	23	19	29	27	23	20	28	27	23	19	28	26	23	19	29	27	24	20
	KW	1.09	1.09	1.09	1.1	1.22	1.22	1.21	1.22	1.36	1.36	1.36	1.35	1.51	1.51	1.50	1.51	1.68	1.68	1.67	1.7	1.87	1.87	1.87	1.88
	Amps	4.0	4.0	4.0	4.0	4.6	4.6	4.6	4.6	5.2	5.2	5.2	5.2	5.9	5.9	5.9	5.9	6.7	6.7	6.7	6.7	7.6	7.6	7.6	7.6
525	HI PR	244	245	247	251	282	283	285	289	322	324	325	329	366	367	369	373	412	414	415	419	462	463	465	469
	LO PR	122	124	127	132	130	131	134	140	136	138	141	146	142	143	146	151	147	149	152	157	154	155	158	164
	MBh	18.7	18.9	19.5	20.3	18.5	18.8	19.3	20.1	18.0	18.3	18.8	19.7	17.2	17.5	18.0	18.8	16.2	16.4	17.0	17.8	15.3	15.5	16.1	16.9
	S/T	1.00	0.80	0.67	0.5	1.00	0.81	0.68	0.54	1.00	0.83	0.70	0.6	1.00	0.85	0.72	0.58	1.00	1.00	0.74	0.6	1.00	1.00	0.79	0.65
	ΔT	27	25	22	18	27	25	22	18	28	26	22	19	27	25	22	18	27	25	22	18	28	26	23	19
600	KW	1.10	1.10	1.10	1.1	1.22	1.22	1.22	1.23	1.36	1.36	1.36	1.36	1.51	1.51	1.51	1.52	1.68	1.68	1.68	1.7	1.88	1.88	1.88	1.89
	Amps	4.0	4.0	4.0	4.1	4.6	4.6	4.6	4.6	5.2	5.2	5.2	5.3	5.9	5.9	5.9	6.0	6.7	6.7	6.7	6.7	7.6	7.6	7.6	7.6
	HI PR	246	247	249	253	284	285	287	291	325	326	327	332	368	369	371	375	415	416	417	422	464	465	467	471
	LO PR	124	126	129	134	132	133	136	141	138	140	143	148	143	145	148	153	149	150	153	159	156	157	160	165
	MBh	18.9	19.2	19.8	20.6	18.8	19.0	19.6	20.4	18.3	18.6	19.1	19.9	17.5	17.7	18.3	19.1	16.5	16.7	17.3	18.1	15.6	15.8	16.4	17.2
675	S/T	1.00	0.83	0.70	0.6	1.00	0.84	0.71	0.57	1.00	0.86	0.73	0.6	1.00	1.00	0.75	0.62	1.00	1.00	0.77	0.6	1.00	1.00	0.82	0.69
	ΔT	26	25	21	17	26	24	21	17	27	25	21	18	26	24	21	17	26	24	21	17	27	25	22	18
	KW	1.10	1.10	1.10	1.1	1.23	1.23	1.23	1.24	1.37	1.37	1.37	1.37	1.52	1.52	1.52	1.53	1.69	1.69	1.69	1.7	1.89	1.89	1.88	1.89
	Amps	4.1	4.1	4.0	4.1	4.6	4.6	4.6	4.7	5.3	5.3	5.3	5.3	6.0	6.0	5.9	6.0	6.7	6.7	6.7	6.8	7.6	7.6	7.6	7.7
	HI PR	248	249	251	255	286	287	289	293	327	328	329	334	370	371	373	377	417	418	419	424	466	467	469	473
LO PR	126	128	131	136	134	135	138	143	140	141	145	150	145	147	150	155	151	152	155	161	158	159	162	167	

IDB	AIRFLOW	OUTDOOR AMBIENT TEMPERATURE												ENTERING INDOOR WET BULB TEMPERATURE											
		65				75				85				95				105				115			
		59	63	67	71	59	63	67	71	59	63	67	71	59	63	67	71	59	63	67	71	59	63	67	71
85	MBh	18.7	19.0	19.5	20.4	18.6	18.8	19.4	20.2	18.1	18.3	18.9	19.7	17.3	17.5	18.1	18.9	16.3	16.5	17.1	17.9	15.3	15.6	16.1	17.0
	S/T	1.00	0.84	0.71	0.58	1.00	0.85	0.72	0.58	1.00	1.00	0.74	0.61	1.00	1.00	0.76	0.62	1.00	1.00	0.78	0.64	1.00	1.00	1.00	0.69
	ΔT	32	30	27	23	32	30	27	23	32	30	27	23	32	30	27	23	32	30	26	23	33	31	28	24
	KW	1.09	1.09	1.09	1.10	1.22	1.22	1.22	1.23	1.36	1.36	1.36	1.37	1.51	1.51	1.51	1.52	1.68	1.68	1.68	1.69	1.88	1.88	1.87	1.88
	Amps	4.0	4.0	4.0	4.0	4.6	4.6	4.6	4.6	5.2	5.2	5.2	5.3	5.9	5.9	5.9	5.9	6.7	6.7	6.7	6.7	7.6	7.6	7.6	7.6
525	HI PR	245	246	248	252	283	284	286	290	324	325	326	331	367	368	370	374	414	415	416	421	463	464	466	470
	LO PR	124	126	129	134	132	133	136	141	138	140	143	148	144	145	148	153	149	150	154	159	156	157	160	165
	MBh	19.0	19.2	19.8	20.6	18.8	19.1	19.6	20.4	18.3	18.6	19.1	20.0	17.5	17.8	18.3	19.1	16.5	16.8	17.3	18.1	15.6	15.8	16.4	17.2
	S/T	1.00	0.90	0.77	0.63	1.00	0.90	0.77	0.64	1.00	1.00	0.80	0.66	1.00	1.00	0.82	0.68	1.00	1.00	0.84	0.70	1.00	1.00	1.00	0.75
	ΔT	31	29	26	22	31	29	26	22	31	29	26	22	31	29	26	22	31	29	25	22	32	30	26	23
600	KW	1.10	1.10	1.10	1.11	1.23	1.23	1.22	1.23	1.37	1.37	1.36	1.37	1.52	1.52	1.51	1.52	1.69	1.68	1.68	1.69	1.88	1.88	1.88	1.89
	Amps	4.0	4.0	4.0	4.1	4.6	4.6	4.6	4.6	5.3	5.2	5.2	5.3	5.9	5.9	5.9	6.0	6.7	6.7	6.7	6.7	7.6	7.6	7.6	7.7
	HI PR	247	248	250	254	285	287	288	292	326	327	328	333	369	370	372	376	416	417	418	423	465	467	468	472
	LO PR	126	127	131	136	133	135	138	143	140	141	144	150	145	147	150	155	151	152	155	160	157	159	162	167
	MBh	19.3	19.5	20.1	20.9	19.1	19.4	19.9	20.7	18.6	18.9	19.4	20.3	17.8	18.1	18.6	19.4	16.8	17.0	17.6	18.4	15.9	16.1	16.7	17.5
675	S/T	1.00	0.93	0.80	0.66	1.00	1.00	0.81	0.67	1.00	1.00	0.83	0.69	1.00	1.00	0.85	0.71	1.00	1.00	0.87	0.73	1.00	1.00	1.00	0.78
	ΔT	30	28	25	21	30	28	25	21	30	28	25	21	30	28	25	21	30	28	24	21	31	29	26	22
	KW	1.11	1.11	1.10	1.11	1.23	1.23	1.23	1.24	1.37	1.37	1.37	1.38	1.52	1.52	1.52	1.53	1.69	1.69	1.69	1.70	1.89	1.89	1.89	1.90
	Amps	4.1	4.1	4.1	4.1	4.6	4.6	4.6	4.7	5.3	5.3	5.3	5.3	6.0	6.0	6.0	6.0	6.7	6.7	6.7	6.8	7.6	7.6	7.6	7.7
	HI PR	249	250	252	256	287	289	290	294	328	329	330	335	371	372	374	378	418	419	420	425	467	469	470	474
LO PR	128	129	133	138	135	137	140	145	142	143	146	152	147	149	152	157	153	154	157	162	159	161	164	169	

IDB: Entering Indoor Dry Bulb Temperature
 High and low pressures are measured at the liquid and suction service valves.
 Shaded area reflects AHRI conditions
 kW = Total system power
 Amps = outdoor unit amps (comp.+fan)

IDB		OUTDOOR AMBIENT TEMPERATURE																																																			
		65								75								85								95								105								115											
		AIRFLOW						59						63						67						71						59						63						67						71			
550		600		675		70		550		600		675		70		550		600		675		70		550		600		675		70		550		600		675		70		550		600		675		70							
MBh	18.1	18.4	18.9	-	18.0	18.2	18.8	-	17.5	17.8	18.3	-	16.7	17.0	17.5	-	15.7	16.0	16.5	-	14.8	15.1	15.6	-	14.8	15.1	15.6	-	15.7	16.0	16.5	-	15.7	16.0	16.5	-	14.8	15.1	15.6	-	15.7	16.0	16.5	-									
S/T	0.65	0.57	0.44	-	0.65	0.58	0.45	-	0.68	0.60	0.47	-	1.00	0.62	0.49	-	1.00	0.64	0.51	-	1.00	0.69	0.56	-	1.00	0.69	0.56	-	1.00	0.64	0.51	-	1.00	0.67	0.54	-	1.00	0.72	0.59	-	1.00	0.69	0.56	-									
ΔT	20	18	14	-	20	18	14	-	20	18	14	-	20	18	14	-	20	18	14	-	21	19	15	-	21	19	15	-	21	18	14	-	20	17	13	-	20	18	14	-	20	18	14	-									
KW	1.05	1.05	1.05	-	1.17	1.17	1.16	-	1.30	1.30	1.29	-	1.44	1.44	1.43	-	1.59	1.59	1.59	-	1.78	1.78	1.77	-	1.78	1.78	1.77	-	1.59	1.59	1.59	-	1.60	1.60	1.59	-	1.78	1.78	1.78	-	1.78	1.78	1.77	-									
Amps	3.9	3.9	3.9	-	4.4	4.4	4.4	-	5.0	5.0	5.0	-	5.7	5.7	5.6	-	6.4	6.4	6.4	-	7.2	7.2	7.2	-	7.2	7.2	7.2	-	6.4	6.4	6.4	-	6.4	6.4	6.4	-	7.2	7.2	7.2	-	7.2	7.2	7.2	-									
HI PR	240	241	242	-	277	278	280	-	316	318	319	-	359	360	362	-	404	405	407	-	453	454	456	-	453	454	456	-	404	405	407	-	404	405	407	-	453	454	456	-	453	454	456	-									
LO PR	125	126	129	-	132	134	137	-	139	140	143	-	144	146	149	-	150	151	154	-	156	158	161	-	156	158	161	-	150	151	154	-	150	151	154	-	156	158	161	-	156	158	161	-									
MBh	18.3	18.6	19.1	-	18.2	18.4	19.0	-	17.7	18.0	18.5	-	16.9	17.2	17.7	-	15.9	16.2	16.7	-	15.0	15.3	15.8	-	15.0	15.3	15.8	-	15.9	16.2	16.7	-	15.9	16.2	16.7	-	15.0	15.3	15.8	-	15.0	15.3	15.8	-									
S/T	0.67	0.60	0.47	-	0.68	0.61	0.47	-	0.70	0.63	0.50	-	1.00	0.65	0.52	-	1.00	0.67	0.54	-	1.00	0.72	0.59	-	1.00	0.72	0.59	-	1.00	0.67	0.54	-	1.00	0.69	0.56	-	1.00	0.74	0.61	-	1.00	0.74	0.61	-									
ΔT	19	17	13	-	19	17	13	-	19	17	14	-	19	17	13	-	19	17	13	-	20	18	14	-	20	18	14	-	19	17	13	-	19	17	13	-	20	18	14	-	20	18	14	-									
KW	1.05	1.05	1.05	-	1.17	1.17	1.17	-	1.30	1.30	1.30	-	1.44	1.44	1.44	-	1.60	1.60	1.59	-	1.78	1.78	1.78	-	1.78	1.78	1.78	-	1.60	1.60	1.59	-	1.60	1.60	1.59	-	1.78	1.78	1.78	-	1.78	1.78	1.78	-									
Amps	3.9	3.9	3.9	-	4.4	4.4	4.4	-	5.0	5.0	5.0	-	5.7	5.7	5.7	-	6.4	6.4	6.4	-	7.2	7.2	7.2	-	7.2	7.2	7.2	-	6.4	6.4	6.4	-	6.4	6.4	6.4	-	7.2	7.2	7.2	-	7.2	7.2	7.2	-									
HI PR	241	242	244	-	279	280	281	-	318	319	321	-	360	361	363	-	406	407	409	-	455	456	457	-	455	456	457	-	406	407	409	-	406	407	409	-	455	456	457	-	455	456	457	-									
LO PR	126	128	131	-	133	135	138	-	140	142	145	-	146	147	150	-	151	152	156	-	158	159	162	-	158	159	162	-	151	152	156	-	151	152	156	-	158	159	162	-	158	159	162	-									
MBh	18.7	18.9	19.5	-	18.5	18.8	19.3	-	18.1	18.3	18.9	-	17.3	17.5	18.1	-	16.3	16.5	17.1	-	15.4	15.6	16.2	-	15.4	15.6	16.2	-	16.3	16.5	17.1	-	16.3	16.5	17.1	-	15.4	15.6	16.2	-	15.4	15.6	16.2	-									
S/T	0.69	0.62	0.49	-	0.70	0.62	0.49	-	0.72	0.65	0.52	-	1.00	0.67	0.53	-	1.00	0.69	0.56	-	1.00	0.74	0.61	-	1.00	0.74	0.61	-	1.00	0.69	0.56	-	1.00	0.69	0.56	-	1.00	0.74	0.61	-	1.00	0.74	0.61	-									
ΔT	18	16	13	-	18	16	12	-	18	16	13	-	18	16	12	-	18	16	12	-	19	17	13	-	19	17	13	-	18	16	12	-	18	16	12	-	19	17	13	-	19	17	13	-									
KW	1.06	1.06	1.06	-	1.18	1.17	1.17	-	1.30	1.30	1.30	-	1.45	1.44	1.44	-	1.60	1.60	1.60	-	1.79	1.79	1.78	-	1.79	1.79	1.78	-	1.60	1.60	1.60	-	1.60	1.60	1.60	-	1.79	1.79	1.78	-	1.79	1.79	1.78	-									
Amps	3.9	3.9	3.9	-	4.5	4.5	4.5	-	5.1	5.1	5.0	-	5.7	5.7	5.7	-	6.4	6.4	6.4	-	7.3	7.3	7.2	-	7.3	7.3	7.2	-	6.4	6.4	6.4	-	6.4	6.4	6.4	-	7.3	7.3	7.2	-	7.3	7.3	7.2	-									
HI PR	243	244	246	-	281	282	283	-	320	321	323	-	362	363	365	-	408	409	411	-	457	458	459	-	457	458	459	-	408	409	411	-	408	409	411	-	457	458	459	-	457	458	459	-									
LO PR	128	130	133	-	136	137	141	-	142	144	147	-	148	149	153	-	153	155	158	-	160	162	165	-	160	162	165	-	153	155	158	-	153	155	158	-	160	162	165	-	160	162	165	-									
MBh	18.2	18.4	18.9	19.8	18.0	18.2	18.8	19.6	17.5	17.8	18.3	19.1	16.7	17.0	17.5	18.3	15.7	16.0	16.5	17.3	14.8	15.1	15.6	16.4	15.7	16.0	16.5	17.3	15.7	16.0	16.5	17.3	15.7	16.0	16.5	17.3	15.7	16.0	16.5	17.3	15.7	16.0	16.5	17.3									
S/T	0.77	0.70	0.57	0.43	0.78	0.70	0.57	0.43	1.00	0.76	0.62	0.48	1.00	0.75	0.62	0.48	1.00	0.80	0.66	0.53	1.00	1.00	0.71	0.58	1.00	0.77	0.64	0.50	1.00	0.80	0.66	0.53	1.00	0.80	0.66	0.53	1.00	1.00	0.71	0.58	1.00	0.80	0.66	0.53									
ΔT	24	22	18	15	24	22	18	15	24	22	18	14	24	22	18	14	23	21	17	14	24	22	19	16	25	24	22	18	14	25	24	22	18	14	24	22	19	15	24	22	18	14											
KW	1.05	1.05	1.05	1.06	1.17	1.16	1.16	1.17	1.30	1.29	1.29	1.30	1.44	1.43	1.43	1.44	1.59	1.59	1.59	1.60	1.78	1.78	1.77	1.78	1.59	1.59	1.59	1.60	1.78	1.78	1.79	1.60	1.60	1.59	1.60	1.60	1.59	1.60	1.60	1.59	1.60												
Amps	3.9	3.9	3.9	3.9	4.4	4.4	4.4	4.4	5.0	5.0	5.0	5.0	5.7	5.7	5.7	6.4	6.4	6.4	6.4	7.2	7.2	7.2	7.2	6.4	6.4	6.4	6.4	7.2	7.2	7.2	6.4	6.4	6.4	6.4	6.4	6.4	6.4	6.4	6.4	6.4													
HI PR	240	241	243	247	277	278	280	284	317	318	319	324	359	360	362	366	405	406	407	411	453	454	456	460	405	406	407	411	453	454	456	460	411	411	411	411	411	411	411	411	411												
LO PR	125	126	129	134	132	134	137	142	139	140	143	148	144	146	149	154	150	151	154	159	156	158	161	166	150	151	154	159	156	158	161	166	166	166	166	166	166	166	166	166													
MBh	18.4	18.6	19.1	20.0	18.2	18.4	19.0	19.8	17.7	18.0	18.5	19.3	16.9	17.2	17.7	18.5	15.9	16.2	16.7	17.5	15.0	15.3	15.8	16.6	16.9	17.2	17.7	18.5	15.9	16.2	16.7	17.5	15.9	16.2	16.7	17.5	15.9	16.2	16.7	17.5													
S/T	0.80	0.73	0.59	0.45	1.00	0.73	0.60	0.46	1.00	0.76	0.62	0.48	1.00	0.77	0.64	0.50	1.00	0.80	0.66	0.53	1.00	1.00	0.71	0.58	1.00	0.77	0.64	0.50	1.00	0.80	0.66	0.53	1.00	0.80	0.66	0.53	1.00	1.00	0.71														

IDB		OUTDOOR AMBIENT TEMPERATURE												ENTERING INDOOR WET BULB TEMPERATURE																																																																																																																																																																								
		65						75						85						95						105						115																																																																																																																																																						
		59	63	67	71	75	79	59	63	67	71	75	79	59	63	67	71	75	79	59	63	67	71	75	79	59	63	67	71	75	79	59	63	67	71	75	79																																																																																																																																																	
550	MBh	18.2	18.5	19.0	19.8	18.1	18.3	18.9	19.7	17.6	17.9	18.4	19.2	16.8	17.1	17.6	18.4	15.8	16.1	16.6	17.4	14.9	15.2	15.7	16.5	S/T	1.00	0.82	0.69	0.6	1.00	0.83	0.69	0.56	1.00	0.85	0.72	0.6	1.00	0.85	0.74	0.60	1.00	0.85	0.76	0.6	1.00	0.80	0.76	0.6	1.00	0.80	0.81	0.67	ΔT	28	26	23	19	28	26	23	19	29	27	23	19	28	26	23	19	29	28	26	22	19	29	27	24	20	KW	1.05	1.05	1.05	1.1	1.17	1.17	1.16	1.17	1.30	1.30	1.29	1.3	1.44	1.44	1.43	1.44	1.59	1.59	1.59	1.59	1.6	1.78	1.78	1.77	1.78	Amps	3.9	3.9	3.9	3.9	4.4	4.4	4.4	4.5	5.0	5.0	5.0	5.0	5.7	5.7	5.6	5.7	6.4	6.4	6.4	6.4	6.4	7.2	7.2	7.2	7.2	HI PR	240	241	243	247	278	279	281	285	317	318	320	324	359	360	362	366	405	406	408	412	454	455	456	461	LO PR	125	127	130	135	133	134	137	142	139	141	144	149	145	146	149	155	150	152	155	160	157	158	162	167
80	MBh	18.4	18.7	19.2	20.0	18.3	18.5	19.1	19.9	17.8	18.1	18.6	19.4	17.0	17.3	17.8	18.6	16.0	16.3	16.8	17.6	15.1	15.4	15.9	16.7	S/T	1.00	0.85	0.72	0.6	1.00	0.85	0.72	0.58	1.00	0.88	0.75	0.6	1.00	0.88	0.76	0.6	1.00	0.88	0.79	0.7	1.00	0.80	0.84	0.70	ΔT	28	26	22	18	28	26	22	18	28	26	22	18	28	26	22	18	27	25	21	17	26	24	22	18	KW	1.05	1.05	1.05	1.1	1.17	1.17	1.17	1.18	1.30	1.30	1.30	1.3	1.44	1.44	1.44	1.45	1.60	1.60	1.60	1.6	1.78	1.78	1.78	1.79	Amps	3.9	3.9	3.9	3.9	4.4	4.4	4.4	4.5	5.0	5.0	5.0	5.1	5.7	5.7	5.7	5.7	6.4	6.4	6.4	6.4	7.2	7.2	7.2	7.3	HI PR	242	243	244	249	279	280	282	286	319	320	321	325	361	362	364	368	406	408	409	413	455	456	458	462	LO PR	127	128	131	136	134	136	139	144	141	142	145	150	146	148	151	156	152	153	156	161	158	160	163	168							
	600	MBh	18.8	19.1	19.6	20.4	18.6	18.9	19.4	20.2	18.2	18.4	19.0	19.8	17.4	17.6	18.2	19.0	16.4	16.6	17.2	18.0	15.5	15.7	16.3	17.1	S/T	1.00	0.86	0.73	0.6	1.00	0.87	0.74	0.60	1.00	0.89	0.76	0.6	1.00	0.89	0.78	0.64	1.00	0.89	0.80	0.7	1.00	0.80	0.85	0.71	ΔT	27	25	21	17	27	25	21	17	27	25	21	17	27	25	21	17	26	24	21	17	26	24	22	18	KW	1.06	1.06	1.06	1.1	1.18	1.17	1.17	1.18	1.30	1.30	1.30	1.3	1.45	1.44	1.44	1.45	1.60	1.60	1.60	1.6	1.79	1.78	1.78	1.79	Amps	3.9	3.9	3.9	4.0	4.5	4.5	4.4	4.5	5.1	5.1	5.0	5.1	5.7	5.7	5.7	5.7	6.4	6.4	6.4	6.4	7.3	7.3	7.3	7.3	HI PR	244	245	247	251	281	282	284	288	321	322	323	328	363	364	366	370	409	410	411	416	457	458	460	464	LO PR	129	130	134	139	136	138	141	146	143	144	148	153	149	150	153	158	154	155	159	164	161	162	165	171						
	675	MBh	18.5	18.8	19.3	20.2	18.4	18.6	19.2	20.0	17.9	18.2	18.7	19.5	17.1	17.4	17.9	18.7	16.1	16.4	16.9	17.7	15.2	15.5	16.0	16.8	S/T	1.00	0.92	0.79	0.65	1.00	0.90	0.79	0.65	1.00	0.90	0.84	0.71	1.00	0.90	0.86	0.72	1.00	0.90	0.88	0.75	1.00	0.80	0.85	0.71	ΔT	32	30	27	23	32	30	27	23	32	30	26	22	31	29	26	22	31	29	26	22	32	30	27	24	KW	1.05	1.05	1.05	1.06	1.17	1.17	1.17	1.17	1.30	1.30	1.30	1.30	1.44	1.44	1.44	1.44	1.60	1.59	1.59	1.60	1.78	1.78	1.78	1.79	Amps	3.9	3.9	3.9	3.9	4.4	4.4	4.4	4.5	5.0	5.0	5.0	5.1	5.7	5.7	5.7	5.7	6.4	6.4	6.4	6.4	7.2	7.2	7.2	7.3	HI PR	241	242	244	248	279	280	282	286	318	319	321	325	361	362	363	367	406	407	409	413	455	456	458	462	LO PR	127	128	132	137	134	136	139	144	141	143	146	151	147	148	151	156	152	153	157	162	159	160	163	169						
	85	MBh	18.7	19.0	19.5	20.4	18.6	18.8	19.4	20.2	18.1	18.4	18.9	19.7	17.3	17.6	18.1	18.9	16.3	16.6	17.1	17.9	15.4	15.7	16.2	17.0	S/T	1.00	0.95	0.81	0.67	1.00	0.90	0.82	0.68	1.00	0.90	0.84	0.71	1.00	0.90	0.86	0.72	1.00	0.90	0.88	0.75	1.00	0.80	0.85	0.71	ΔT	31	29	26	22	31	29	26	22	32	30	26	22	31	29	26	22	31	29	26	22	32	30	27	23	KW	1.06	1.06	1.06	1.07	1.18	1.17	1.17	1.18	1.30	1.30	1.30	1.31	1.44	1.44	1.44	1.45	1.60	1.60	1.60	1.61	1.78	1.78	1.78	1.79	Amps	3.9	3.9	3.9	3.9	4.5	4.4	4.4	4.5	5.0	5.0	5.0	5.1	5.7	5.7	5.7	5.7	6.4	6.4	6.4	6.4	7.2	7.2	7.2	7.3	HI PR	243	244	246	250	280	281	283	287	320	321	322	327	362	363	365	369	408	409	410	414	456	457	459	463	LO PR	128	130	133	138	136	137	141	146	142	144	147	152	148	149	153	158	153	155	158	163	160	162	165	170						
		600	MBh	19.1	19.4	19.9	20.7	18.9	19.2	19.7	20.5	18.5	18.7	19.3	20.1	17.7	17.9	18.5	19.3	16.7	16.9	17.5	18.3	15.8	16.0	16.6	17.4	S/T	1.00	0.96	0.83	0.69	1.00	0.90	0.84	0.70	1.00	0.90	0.86	0.72	1.00	0.90	0.88	0.74	1.00	0.90	0.88	0.76	1.00	0.80	0.85	0.71	ΔT	30	28	25	21	30	28	25	21	31	29	25	21	30	28	25	21	30	28	25	21	31	29	26	22	KW	1.06	1.06	1.06	1.07	1.18	1.18	1.17	1.18	1.31	1.31	1.30	1.31	1.45	1.45	1.44	1.45	1.60	1.60	1.60	1.61	1.79	1.79	1.79	1.79	Amps	3.9	3.9	3.9	4.0	4.5	4.5	4.5	4.5	5.1	5.1	5.1	5.1	5.7	5.7	5.7	5.7	6.4	6.4	6.4	6.5	7.3	7.3	7.3	7.3	HI PR	245	246	248	252	283	284	285	289	322	323	325	329	364	365	367	371	410	411	412	417	458	459	461	465	LO PR	131	132	135	141	138	140	143	148	145	146	149	155	150	152	155	160	156	157	160	166	163	164	167	172					
675		MBh	19.1	19.4	19.9	20.7	18.9	19.2	19.7	20.5	18.5	18.7	19.3	20.1	17.7	17.9	18.5	19.3	16.7	16.9	17.5	18.3	15.8	16.0	16.6	17.4	S/T	1.00	0.96	0.83	0.69	1.00	0.90	0.84	0.70	1.00	0.90	0.86	0.72	1.00	0.90	0.88	0.74	1.00	0.90	0.88	0.76	1.00	0.80	0.85	0.71	ΔT	30	28	25	21	30	28	25	21	31	29	25	21	30	28	25	21	30	28	25	21	31	29	26	22	KW	1.06	1.06	1.06	1.07	1.18	1.18	1.17	1.18	1.31	1.31	1.30	1.31	1.45	1.45	1.44	1.45	1.60	1.60	1.60	1.61	1.79	1.79	1.79	1.79	Amps	3.9	3.9	3.9	4.0	4.5	4.5	4.5	4.5	5.1	5.1	5.1	5.1	5.7	5.7	5.7	5.7	6.4	6.4	6.4	6.5	7.3	7.3	7.3	7.3	HI PR	245	246	248	252	283	284	285	289	322	323	325	329	364	365	367	371	410	411	412	417	458	459	461	465	LO PR	131	132	135	141	138	140	143	148	145	146	149	155	150	152	155	160	156	157	160	166	163	164	167	172						

IDB: Entering Indoor Dry Bulb Temperature
 High and low pressures are measured at the liquid and suction service valves.
 Shaded area reflects AHRI conditions
 kW = Total system power
 Amps = outdoor unit amps (comp.+fan)

IDB		OUTDOOR AMBIENT TEMPERATURE												ENTERING INDOOR WET BULB TEMPERATURE																							
		65						75						85						95						105						115					
		59	63	67	71	75	79	59	63	67	71	75	79	59	63	67	71	75	79	59	63	67	71	75	79	59	63	67	71	75	79	59	63	67	71	75	79
700	MBh	24.5	24.9	25.6	26.7	28.2	24.3	24.7	25.4	26.5	28.0	23.7	24.0	24.7	25.8	27.3	22.6	22.9	23.7	24.8	26.3	21.3	21.6	22.3	23.4	24.9	26.5	20.1	20.4	21.1	-	-	-				
	S/T	0.63	0.56	0.43	-	-	0.63	0.56	0.43	-	-	0.66	0.59	0.46	-	-	0.68	0.60	0.48	-	-	1.00	0.62	0.50	-	-	1.00	0.67	0.55	-	-	-					
	ΔT	20	18	15	-	-	20	18	15	-	-	21	19	15	-	-	20	18	15	-	-	20	18	14	-	-	21	19	16	-	-	-					
	KW	1.41	1.40	1.40	-	-	1.57	1.57	1.57	-	-	1.75	1.75	1.75	-	-	1.95	1.95	1.95	-	-	2.17	2.17	2.17	-	-	2.43	2.43	2.43	-	-	-					
	Amps	5.3	5.3	5.2	-	-	6.0	6.0	6.0	-	-	6.9	6.8	6.8	-	-	7.8	7.8	7.7	-	-	8.8	8.8	8.8	-	-	10.0	10.0	10.0	-	-	-					
800	MBh	25.0	25.3	26.0	27.2	28.7	24.8	25.1	25.8	27.5	29.0	24.1	24.5	25.2	26.9	28.4	23.0	23.4	24.1	25.8	27.5	21.7	22.1	22.8	24.1	25.8	27.5	20.5	20.8	21.6	-	-	-				
	S/T	0.66	0.59	0.46	-	-	0.67	0.60	0.47	-	-	0.69	0.62	0.49	-	-	0.71	0.64	0.51	-	-	1.00	0.66	0.53	-	-	1.00	0.71	0.58	-	-	-					
	ΔT	19	17	14	-	-	19	17	13	-	-	19	17	14	-	-	19	17	13	-	-	19	17	13	-	-	20	18	14	-	-	-					
	KW	1.41	1.41	1.41	-	-	1.58	1.58	1.57	-	-	1.76	1.76	1.76	-	-	1.96	1.96	1.96	-	-	2.18	2.18	2.18	-	-	2.44	2.44	2.44	-	-	-					
	Amps	5.3	5.3	5.3	-	-	6.1	6.0	6.0	-	-	6.9	6.9	6.9	-	-	7.8	7.8	7.8	-	-	8.8	8.8	8.8	-	-	10.0	10.0	10.0	-	-	-					
900	MBh	25.5	25.9	26.6	27.8	29.3	25.3	25.6	26.4	28.1	29.6	24.7	25.0	25.7	27.4	28.9	23.6	23.9	24.6	26.3	27.9	22.3	22.6	23.3	25.0	26.6	28.2	21.0	21.4	22.1	-	-	-				
	S/T	0.67	0.60	0.47	-	-	0.68	0.60	0.48	-	-	0.70	0.63	0.50	-	-	0.72	0.65	0.52	-	-	1.00	0.67	0.54	-	-	1.00	0.72	0.59	-	-	-					
	ΔT	18	16	13	-	-	18	16	12	-	-	18	16	13	-	-	18	16	12	-	-	18	16	12	-	-	19	17	13	-	-	-					
	KW	1.42	1.42	1.42	-	-	1.59	1.58	1.58	-	-	1.77	1.77	1.76	-	-	1.97	1.97	1.96	-	-	2.19	2.19	2.19	-	-	2.45	2.45	2.45	-	-	-					
	Amps	5.3	5.3	5.3	-	-	6.1	6.1	6.1	-	-	6.9	6.9	6.9	-	-	7.8	7.8	7.8	-	-	8.8	8.8	8.8	-	-	10.0	10.0	10.0	-	-	-					
700	MBh	24.5	24.9	25.6	26.7	28.2	24.3	24.7	25.4	26.5	28.0	23.7	24.0	24.8	26.3	27.8	22.6	23.0	23.7	24.8	26.3	21.3	21.6	22.3	23.4	24.9	26.5	20.1	20.4	21.1	-	-	-				
	S/T	0.75	0.68	0.55	0.42	-	0.76	0.68	0.56	0.42	-	1.00	0.71	0.58	0.44	-	1.00	0.73	0.63	0.50	-	1.00	0.78	0.65	0.52	-	1.00	0.80	0.67	0.53	-	-	-				
	ΔT	25	23	19	15	-	25	23	19	15	-	25	23	19	15	-	25	23	19	15	-	24	22	19	15	-	26	24	20	16	-	-	-				
	KW	1.40	1.40	1.40	1.41	-	1.57	1.57	1.56	1.58	-	1.75	1.75	1.75	1.76	-	1.95	1.95	1.95	1.96	-	2.17	2.17	2.17	2.18	-	2.43	2.43	2.43	2.44	-	-	-				
	Amps	5.3	5.2	5.2	5.3	-	6.0	6.0	6.0	6.0	-	6.8	6.8	6.8	6.9	-	7.8	7.8	7.7	7.8	-	8.8	8.8	8.8	8.8	-	10.0	10.0	10.0	10.0	-	-	-				
800	MBh	25.0	25.3	26.1	27.2	28.7	24.8	25.1	25.8	27.5	29.0	24.1	24.5	25.2	26.9	28.4	23.0	23.4	24.1	25.8	27.5	21.7	22.1	22.8	24.1	25.8	27.5	20.5	20.9	21.6	-	-	-				
	S/T	0.78	0.71	0.58	0.45	-	0.79	0.72	0.59	0.46	-	1.00	0.74	0.61	0.48	-	1.00	0.76	0.63	0.50	-	1.00	0.78	0.65	0.52	-	1.00	0.80	0.70	0.57	-	-	-				
	ΔT	24	22	18	14	-	24	22	18	14	-	24	22	18	14	-	24	22	18	14	-	23	21	18	14	-	25	23	19	15	-	-	-				
	KW	1.41	1.41	1.41	1.42	-	1.58	1.58	1.57	1.59	-	1.76	1.76	1.76	1.77	-	1.96	1.96	1.96	1.97	-	2.18	2.18	2.18	2.19	-	2.44	2.44	2.44	2.45	-	-	-				
	Amps	5.3	5.3	5.3	5.3	-	6.0	6.0	6.0	6.1	-	6.9	6.9	6.9	6.9	-	7.8	7.8	7.8	7.8	-	8.8	8.8	8.8	8.8	-	10.0	10.0	10.0	10.0	-	-	-				
900	MBh	25.5	25.9	26.6	27.7	29.2	25.3	25.7	26.4	28.1	29.6	24.7	25.0	25.8	27.4	28.9	23.6	23.9	24.6	26.3	27.9	22.3	22.6	23.3	25.0	26.6	28.2	21.0	21.4	22.1	-	-	-				
	S/T	0.79	0.72	0.59	0.46	-	1.00	0.73	0.60	0.46	-	1.00	0.75	0.62	0.49	-	1.00	0.77	0.64	0.51	-	1.00	0.79	0.66	0.53	-	1.00	0.80	0.71	0.57	-	-	-				
	ΔT	23	21	17	13	-	23	21	17	13	-	23	21	17	13	-	23	21	17	13	-	22	20	17	13	-	24	22	18	14	-	-	-				
	KW	1.42	1.42	1.42	1.43	-	1.58	1.58	1.58	1.59	-	1.77	1.77	1.76	1.78	-	1.97	1.96	1.96	1.97	-	2.19	2.19	2.18	2.20	-	2.45	2.45	2.44	2.46	-	-	-				
	Amps	5.3	5.3	5.3	5.4	-	6.1	6.1	6.1	6.1	-	6.9	6.9	6.9	7.0	-	7.8	7.8	7.8	7.9	-	8.8	8.8	8.8	8.9	-	10.0	10.0	10.0	10.1	-	-	-				
75	MBh	24.5	24.9	25.6	26.7	28.2	24.3	24.7	25.4	26.5	28.0	23.7	24.0	24.8	26.3	27.8	22.6	23.0	23.7	24.8	26.3	21.3	21.6	22.3	23.4	24.9	26.5	20.1	20.4	21.1	-	-	-				
	S/T	0.78	0.71	0.58	0.45	-	0.79	0.72	0.59	0.46	-	1.00	0.74	0.61	0.48	-	1.00	0.76	0.63	0.50	-	1.00	0.78	0.65	0.52	-	1.00	0.80	0.70	0.57	-	-	-				
	ΔT	24	22	18	14	-	24	22	18	14	-	24	22	18	14	-	24	22	18	14	-	23	21	18	14	-	25	23	19	15	-	-	-				
	KW	1.41	1.41	1.41	1.42	-	1.58	1.58	1.57	1.59	-	1.76	1.76	1.76	1.77	-	1.96	1.96	1.96	1.97	-	2.18	2.18	2.18	2.19	-	2.44	2.44	2.44	2.45	-	-	-				
	Amps	5.3	5.3	5.3	5.3	-	6.0	6.0	6.0	6.1	-	6.9	6.9	6.9	6.9	-	7.8	7.8	7.8	7.8	-	8.8	8.8	8.8	8.8	-	10.0	10.0	10.0	10.0	-	-	-				
75	MBh	25.0	25.3	26.1	27.2	28.7	24.8	25.1	25.8	27.5	29.0	24.1	24.5	25.2	26.9	28.4	23.0	23.4	24.1	25.8	27.5	21.7	22.1	22.8	24.1	25.8	27.5	20.5	20.9	21.6	-	-	-				
	S/T	0.78	0.71	0.58	0.45	-	0.79	0.72	0.59	0.46	-	1.00	0.74	0.61	0.48	-	1.00	0.76	0.63	0.50	-	1.00	0.78	0.65	0.52	-	1.00	0.80	0.70	0.57	-	-	-				
	ΔT	24	22	18	14	-	24	22	18	14	-	24	22	18	14	-	24	22	18	14	-	23	21	18	14	-	25	23	19	15	-	-	-				
	KW	1.41	1.41	1.41	1.42	-	1.58	1.58	1.57	1.59	-	1.76	1.76	1.76	1.77	-	1.96	1.96	1.96	1.97	-	2.18	2.18	2.18	2.19	-	2.44	2.44	2.44	2.45	-	-	-				
	Amps	5.3	5.3	5.3	5.3	-	6.0	6.0	6.0	6.1	-	6.9	6.9	6.9	6.9	-	7.8	7.8	7.8	7.8	-	8.8	8.8	8.8	8.8	-	10.0	10.0	10.0	10.0	-	-	-				
75	MBh	25.5	25.9	26.6	27.7	29.2	25.3	25.7	26.4	28.1	29.6	24.7	25.0	25.8	27.4	28.9	23.6	23.9	24.6	26.3	27.9	22.3	22.6	23.3	25.0	26.6	28.2	21.0	21.4	22.1	-	-	-				
	S/T	0.79	0.72	0.59	0.46	-	1.00	0.73	0.60	0.46	-	1.00	0.75	0.62	0.49	-	1.00	0.77	0.64	0.51	-	1.00	0.79	0.66	0.53	-	1.00	0.80	0.71	0.57	-	-	-				
	ΔT	23	21	17	13	-	23	21	17	13	-	23	21	17	13	-	23	21	17	13	-	22	20	17	13	-	24	22	18	14	-	-	-				
	KW	1.42	1.42	1.42	1.43	-	1.58	1.58	1.58	1.59	-	1.77	1.77	1.76	1.78	-	1.97	1.96	1.96	1.97	-	2.19	2.19	2.18	2.20	-	2.45	2.45	2.44	2.46	-	-	-				
	Amps	5.3	5.3	5.3	5.4	-	6.1	6.1	6.1	6.1	-	6.9	6.9	6.9	7.0	-	7.8	7.8	7.8	7.9	-	8.8	8.8	8.8	8.9	-	10.0	10.0	10.0	10.1	-	-	-				
75	MBh	25.5	25.9	26.6	27.7	29.2	25.3	25.7	26.4	28.1	29.6	24.7	25.0	25.8	27.4	28.9	23.6	23.9	24.6	26.3	27.9	22.3	22.6	23.3	25.0	26.											

IDB		OUTDOOR AMBIENT TEMPERATURE																																															
		75												85												105												115											
		65						75						85						95						105						115																	
AIRFLOW		ENTERING INDOOR WET BULB TEMPERATURE																																															
		59	63	67	71	59	63	67	71	59	63	67	71	59	63	67	71	59	63	67	71	59	63	67	71	59	63	67	71	59	63	67	71																
700	MBh	24.5	24.9	25.6	-	24.3	24.7	25.4	-	23.7	24.0	24.7	-	22.6	22.9	23.7	-	21.3	21.6	22.3	-	20.1	20.4	21.1	-	22.6	22.9	23.7	-	21.3	21.6	22.3	-	20.1	20.4	21.1	-												
	S/T	0.63	0.56	0.43	-	0.63	0.56	0.43	-	0.66	0.59	0.46	-	0.68	0.60	0.48	-	1.00	0.62	0.50	-	1.00	0.67	0.55	-	1.00	0.62	0.50	-	1.00	0.62	0.50	-	1.00	0.67	0.55	-												
	ΔT	20	18	15	-	20	18	15	-	21	19	15	-	20	18	15	-	20	18	14	-	21	19	16	-	20	18	15	-	20	18	14	-	21	19	16	-												
	KW	1.41	1.40	1.40	-	1.57	1.57	1.57	-	1.75	1.75	1.75	-	1.95	1.95	1.95	-	2.17	2.17	2.17	-	2.43	2.43	2.43	-	2.17	2.17	2.17	-	2.17	2.17	2.17	-	2.43	2.43	2.43	-												
	Amps	5.3	5.3	5.2	-	6.0	6.0	6.0	-	6.9	6.8	6.8	-	7.8	7.8	7.7	-	8.8	8.8	8.8	-	10.0	10.0	10.0	-	8.8	8.8	8.8	-	8.8	8.8	8.8	-	10.0	10.0	10.0	-												
800	MBh	25.0	25.3	26.0	-	24.8	25.1	25.8	-	24.1	24.5	25.2	-	23.0	23.4	24.1	-	21.7	22.1	22.8	-	20.5	20.8	21.6	-	23.0	23.4	24.1	-	21.7	22.1	22.8	-	20.5	20.8	21.6	-												
	S/T	0.66	0.59	0.46	-	0.67	0.60	0.47	-	0.69	0.62	0.49	-	0.71	0.64	0.51	-	1.00	0.66	0.53	-	1.00	0.71	0.58	-	1.00	0.66	0.53	-	1.00	0.66	0.53	-	1.00	0.71	0.58	-												
	ΔT	19	17	14	-	19	17	13	-	19	17	14	-	19	17	13	-	19	17	13	-	20	18	14	-	19	17	13	-	19	17	13	-	20	18	14	-												
	KW	1.41	1.41	1.41	-	1.58	1.58	1.57	-	1.76	1.76	1.76	-	1.96	1.96	1.96	-	2.18	2.18	2.18	-	2.44	2.44	2.44	-	1.96	1.96	1.96	-	1.96	1.96	1.96	-	2.44	2.44	2.44	-												
	Amps	5.3	5.3	5.3	-	6.1	6.0	6.0	-	6.9	6.9	6.9	-	7.8	7.8	7.8	-	8.8	8.8	8.8	-	10.0	10.0	10.0	-	6.9	6.9	6.9	-	6.9	6.9	6.9	-	10.0	10.0	10.0	-												
900	MBh	25.5	25.9	26.6	-	25.3	25.6	26.4	-	24.7	25.0	25.7	-	23.6	23.9	24.6	-	22.3	22.6	23.3	-	21.0	21.4	22.1	-	23.6	23.9	24.6	-	22.3	22.6	23.3	-	21.0	21.4	22.1	-												
	S/T	0.67	0.60	0.47	-	0.68	0.60	0.48	-	0.70	0.63	0.50	-	1.00	0.65	0.52	-	1.00	0.67	0.54	-	1.00	0.72	0.59	-	1.00	0.65	0.52	-	1.00	0.67	0.54	-	1.00	0.72	0.59	-												
	ΔT	18	16	13	-	18	16	12	-	18	16	13	-	18	16	12	-	18	16	12	-	19	17	13	-	18	16	12	-	18	16	12	-	19	17	13	-												
	KW	1.42	1.42	1.42	-	1.59	1.58	1.58	-	1.77	1.77	1.76	-	1.97	1.97	1.96	-	2.19	2.19	2.19	-	2.45	2.45	2.45	-	1.97	1.97	1.96	-	1.97	1.97	1.96	-	2.45	2.45	2.45	-												
	Amps	5.3	5.3	5.3	-	6.1	6.1	6.1	-	6.9	6.9	6.9	-	7.8	7.8	7.8	-	8.8	8.8	8.8	-	10.0	10.0	10.0	-	6.9	6.9	6.9	-	6.9	6.9	6.9	-	10.0	10.0	10.0	-												
75	MBh	24.5	24.9	25.6	26.7	24.3	24.7	25.4	26.5	23.7	24.0	24.8	25.9	22.6	23.0	23.7	24.8	21.3	21.6	22.3	23.4	20.1	20.4	21.1	22.2	22.6	23.0	23.7	24.8	21.3	21.6	22.3	23.4	20.1	20.4	21.1	22.2												
	S/T	0.75	0.68	0.55	0.42	0.76	0.68	0.56	0.42	1.00	0.71	0.58	0.44	1.00	0.73	0.60	0.46	1.00	0.75	0.62	0.48	1.00	0.80	0.67	0.53	1.00	0.73	0.60	0.46	1.00	0.75	0.62	0.48	1.00	0.80	0.67	0.53												
	ΔT	25	23	19	15	25	23	19	15	25	23	19	15	25	23	19	15	24	22	19	15	26	24	20	16	24	23	19	15	24	22	19	15	26	24	20	16												
	KW	1.40	1.40	1.40	1.41	1.57	1.57	1.56	1.58	1.75	1.75	1.75	1.76	1.95	1.95	1.95	1.96	2.17	2.17	2.17	2.18	2.43	2.43	2.43	2.44	1.95	1.95	1.95	1.96	2.17	2.17	2.17	2.18	2.43	2.43	2.43	2.44												
	Amps	5.3	5.2	5.2	5.3	6.0	6.0	6.0	6.0	6.9	6.8	6.8	6.9	7.8	7.8	7.7	7.8	8.8	8.8	8.8	8.8	10.0	10.0	10.0	10.0	7.8	7.8	7.7	7.8	8.8	8.8	8.8	8.8	10.0	10.0	10.0	10.0												
800	MBh	25.0	25.3	26.1	27.2	24.8	25.1	25.8	26.9	24.1	24.5	25.2	26.3	23.1	23.4	24.1	25.2	21.7	22.1	22.8	23.9	20.5	20.9	21.6	22.7	23.1	23.4	24.1	25.2	21.7	22.1	22.8	23.9	20.5	20.9	21.6	22.7												
	S/T	0.78	0.71	0.58	0.45	0.79	0.72	0.59	0.46	1.00	0.74	0.61	0.48	1.00	0.76	0.63	0.50	1.00	0.78	0.65	0.52	1.00	1.00	0.70	0.57	1.00	0.76	0.63	0.50	1.00	0.78	0.65	0.52	1.00	1.00	0.70	0.57												
	ΔT	24	22	18	14	24	22	18	14	24	22	18	14	24	22	18	14	23	21	18	14	25	23	19	15	23	21	18	14	23	21	18	14	25	23	19	15												
	KW	1.41	1.41	1.41	1.42	1.58	1.58	1.57	1.59	1.76	1.76	1.76	1.77	1.96	1.96	1.96	1.97	2.18	2.18	2.18	2.19	2.44	2.44	2.44	2.45	1.96	1.96	1.96	1.97	2.18	2.18	2.18	2.19	2.44	2.44	2.44	2.45												
	Amps	5.3	5.3	5.3	5.3	6.0	6.0	6.0	6.1	6.9	6.9	6.9	6.9	7.8	7.8	7.8	7.8	8.8	8.8	8.8	8.8	10.0	10.0	10.0	10.0	6.9	7.8	7.8	7.8	8.8	8.8	8.8	8.8	10.0	10.0	10.0	10.0												
900	MBh	25.5	25.9	26.6	27.7	25.3	25.7	26.4	27.5	24.7	25.0	25.8	26.9	23.6	23.9	24.7	25.8	22.3	22.6	23.3	24.4	21.1	21.4	22.1	23.2	23.6	23.9	24.7	25.8	22.3	22.6	23.3	24.4	21.1	21.4	22.1	23.2												
	S/T	0.79	0.72	0.59	0.46	1.00	0.73	0.60	0.46	1.00	0.75	0.62	0.49	1.00	0.77	0.64	0.51	1.00	0.79	0.66	0.53	1.00	1.00	0.71	0.57	1.00	0.77	0.64	0.51	1.00	0.79	0.66	0.53	1.00	1.00	0.71	0.57												
	ΔT	23	21	17	13	23	21	17	13	23	21	17	13	23	21	17	13	22	20	17	13	24	22	18	14	23	21	17	13	22	20	17	13	24	22	18	14												
	KW	1.42	1.42	1.42	1.43	1.58	1.58	1.58	1.59	1.76	1.76	1.76	1.78	1.97	1.96	1.96	1.97	2.19	2.19	2.18	2.20	2.45	2.45	2.44	2.46	1.97	1.96	1.96	1.97	2.19	2.19	2.18	2.20	2.45	2.45	2.44	2.46												
	Amps	5.3	5.3	5.3	5.4	6.1	6.1	6.1	6.1	6.9	6.9	6.9	7.0	7.8	7.8	7.8	7.9	8.8	8.8	8.8	8.8	10.0	10.0	10.0	10.1	6.9	7.8	7.8	7.9	8.8	8.8	8.8	8.9	10.0	10.0	10.0	10.1												
HI PR	258	259	261	265	298	299	301	305	346	339	340	342	346	384	385	387	391	432	433	435	439	483	485	486	491	384	385	387	391	432	433	435	439	483	485	486	491												
LO PR	126	127	130	136	133	135	138	143	149	140	141	144	149	145	146	149	155	150	152	155	160	157	158	161	166	145	146	149	155	150	152	155	160	157	158	161	166												

IDB: Entering Indoor Dry Bulb Temperature
 High and low pressures are measured at the liquid and suction service valves.
 Shaded area reflects ACCA (TVA) conditions
 kW = Total system power
 Amps = outdoor unit amps (comp.+fan)

IDB	AIRFLOW	OUTDOOR AMBIENT TEMPERATURE												ENTERING INDOOR WET BULB TEMPERATURE											
		65				75				85				95				105				115			
		59	63	67	71	59	63	67	71	59	63	67	71	59	63	67	71	59	63	67	71	59	63	67	71
700	MBh	24.7	25.0	25.7	26.8	24.5	24.8	25.5	26.6	23.8	24.2	24.9	26.0	22.7	23.1	23.8	24.9	21.4	21.7	22.5	23.6	20.2	20.5	21.3	22.4
	S/T	0.87	0.80	0.67	0.5	1.00	0.80	0.67	0.54	1.00	0.83	0.70	0.6	1.00	0.84	0.72	0.58	1.00	1.00	0.74	0.6	1.00	1.00	0.79	0.65
	ΔT	29	27	23	20	29	27	23	20	29	27	24	20	29	27	23	20	29	27	23	19	30	28	24	21
	KW	1.41	1.40	1.40	1.4	1.57	1.57	1.57	1.58	1.75	1.75	1.75	1.8	1.95	1.95	1.95	1.96	2.17	2.17	2.17	2.2	2.43	2.43	2.43	2.44
	Amps	5.3	5.3	5.2	5.3	6.0	6.0	6.0	6.1	6.9	6.8	6.8	6.9	7.8	7.8	7.7	7.8	8.8	8.8	8.8	8.8	10.0	10.0	10.0	10.0
800	HI PR	254	255	257	261	293	294	296	301	335	336	338	342	380	381	382	387	428	429	431	435	479	480	482	486
	LO PR	122	123	126	131	129	130	133	139	135	137	140	145	141	142	145	150	146	147	150	156	153	154	157	162
	MBh	25.1	25.5	26.2	27.3	24.9	25.2	26.0	27.1	24.3	24.6	25.3	26.4	23.2	23.5	24.2	25.3	21.8	22.2	22.9	24.0	20.6	21.0	21.7	22.8
	S/T	1.00	0.83	0.70	0.6	1.00	0.84	0.71	0.57	1.00	0.86	0.73	0.6	1.00	0.88	0.75	0.62	1.00	1.00	0.77	0.6	1.00	1.00	0.82	0.69
	ΔT	28	26	22	18	28	26	22	18	28	26	23	19	28	26	22	18	28	26	22	18	29	27	23	19
900	KW	1.41	1.41	1.41	1.4	1.58	1.58	1.57	1.59	1.76	1.76	1.76	1.8	1.96	1.96	1.96	1.97	2.18	2.18	2.18	2.2	2.44	2.44	2.44	2.45
	Amps	5.3	5.3	5.3	5.3	6.0	6.0	6.0	6.1	6.9	6.9	6.9	6.9	7.8	7.8	7.8	7.8	8.8	8.8	8.8	8.9	10.0	10.0	10.0	10.0
	HI PR	256	257	259	263	296	297	299	303	337	338	340	344	382	383	385	389	430	431	433	437	481	483	484	489
	LO PR	124	125	128	133	131	133	136	141	138	139	142	147	143	144	147	152	148	150	153	158	155	156	159	164
	MBh	25.7	26.0	26.7	27.8	25.4	25.8	26.5	27.6	24.8	25.2	25.9	27.0	23.7	24.1	24.8	25.9	22.4	22.7	23.5	24.6	21.2	21.5	22.2	23.3

IDB	AIRFLOW	OUTDOOR AMBIENT TEMPERATURE												ENTERING INDOOR WET BULB TEMPERATURE											
		65				75				85				95				105				115			
		59	63	67	71	59	63	67	71	59	63	67	71	59	63	67	71	59	63	67	71	59	63	67	71
700	MBh	25.1	25.4	26.1	27.2	24.9	25.2	25.9	27.0	24.2	24.6	25.3	26.4	23.1	23.5	24.2	25.3	21.8	22.2	22.9	24.0	20.6	20.9	21.7	22.8
	S/T	1.00	0.89	0.76	0.63	1.00	0.90	0.77	0.63	1.00	1.00	0.79	0.66	1.00	1.00	0.81	0.68	1.00	1.00	0.83	0.70	1.00	1.00	1.00	0.75
	ΔT	33	31	27	24	33	31	27	23	33	31	28	24	33	31	27	23	33	31	27	23	34	32	28	24
	KW	1.41	1.41	1.40	1.42	1.57	1.57	1.57	1.58	1.76	1.76	1.75	1.76	1.96	1.95	1.95	1.96	2.18	2.18	2.17	2.19	2.44	2.44	2.43	2.45
	Amps	5.3	5.3	5.3	5.3	6.0	6.0	6.0	6.1	6.9	6.9	6.8	6.9	7.8	7.8	7.8	7.8	8.8	8.8	8.8	8.8	10.0	10.0	10.0	10.0
800	HI PR	255	256	258	262	295	296	297	302	336	337	339	343	381	382	384	388	429	430	432	436	480	481	483	488
	LO PR	123	125	128	133	131	132	135	140	137	139	142	147	142	144	147	152	148	149	152	157	154	156	159	164
	MBh	25.5	25.9	26.6	27.7	25.3	25.6	26.4	27.5	24.7	25.0	25.7	26.8	23.6	23.9	24.7	25.8	22.3	22.6	23.3	24.4	21.0	21.4	22.1	23.2
	S/T	1.00	0.93	0.80	0.66	1.00	0.93	0.80	0.67	1.00	1.00	0.83	0.69	1.00	1.00	0.85	0.71	1.00	1.00	0.87	0.73	1.00	1.00	1.00	0.78
	ΔT	32	30	26	22	32	30	26	22	32	30	26	23	32	30	26	22	32	30	26	22	33	31	27	23
900	KW	1.42	1.42	1.41	1.42	1.58	1.58	1.58	1.59	1.76	1.76	1.76	1.77	1.96	1.96	1.96	1.97	2.19	2.18	2.18	2.19	2.45	2.44	2.44	2.45
	Amps	5.3	5.3	5.3	5.3	6.1	6.1	6.0	6.1	6.9	6.9	6.9	6.9	7.8	7.8	7.8	7.9	8.8	8.8	8.8	8.9	10.0	10.0	10.0	10.1
	HI PR	257	258	260	265	297	298	300	304	338	339	341	346	383	384	386	390	431	432	434	438	483	484	485	490
	LO PR	126	127	130	135	133	134	137	143	139	141	144	149	145	146	149	154	150	151	154	160	157	158	161	166
	MBh	26.1	26.4	27.1	28.2	25.9	26.2	26.9	28.0	25.2	25.6	26.3	27.4	24.1	24.5	25.2	26.3	22.8	23.1	23.9	25.0	21.6	21.9	22.7	23.8

IDB: Entering Indoor Dry Bulb Temperature
 High and low pressures are measured at the liquid and suction service valves.
 Shaded area reflects AHRI conditions
 KW = Total system power
 Amps = outdoor unit amps (comp.+fan)

IDB		OUTDOOR AMBIENT TEMPERATURE												ENTERING INDOOR WET BULB TEMPERATURE													
		65				75				85				95				105				115					
		59	63	67	71	59	63	67	71	59	63	67	71	59	63	67	71	59	63	67	71	59	63	67	71		
70	875	MBh	29.3	29.7	30.6	31.0	29.0	29.5	30.3	30.7	28.3	28.7	29.6	29.6	27.0	27.4	28.2	28.2	25.3	25.8	26.6	26.6	23.9	24.3	25.2	-	
		S/T	0.59	0.52	0.38	-	0.60	0.52	0.39	-	0.62	0.55	0.42	-	1.00	0.57	0.43	-	1.00	0.59	0.46	-	1.00	0.64	0.51	-	
		ΔT	20	18	15	-	20	18	15	-	20	18	15	-	20	18	15	-	20	18	14	-	21	19	15	-	
		KW	1.76	1.75	1.75	-	1.95	1.95	1.95	-	2.17	2.17	2.17	-	2.41	2.41	2.41	-	2.68	2.68	2.67	-	2.99	2.99	2.99	-	
		Amps	6.4	6.4	6.4	-	7.3	7.3	7.3	-	8.3	8.3	8.3	-	9.4	9.4	9.4	-	10.6	10.6	10.6	-	12.0	12.0	12.0	-	
	HI PR	250	251	252	-	289	290	292	-	330	331	333	-	375	376	377	-	422	424	425	-	474	475	476	-		
	LO PR	124	125	128	-	131	133	136	-	138	139	142	-	143	145	148	-	149	150	154	-	156	157	160	-		
	MBh	29.7	30.1	31.0	-	29.4	29.8	30.7	-	28.7	29.1	29.9	-	27.3	27.8	28.6	-	25.7	26.1	27.0	-	24.3	24.7	25.6	-		
	S/T	0.65	0.58	0.44	-	0.66	0.58	0.45	-	0.68	0.61	0.47	-	1.00	0.63	0.49	-	1.00	0.65	0.51	-	1.00	0.70	0.56	-		
	ΔT	19	17	13	-	19	17	13	-	19	17	14	-	19	17	13	-	18	17	13	-	20	18	14	-		
KW	1.77	1.77	1.76	-	1.96	1.96	1.96	-	2.18	2.18	2.18	-	2.42	2.42	2.42	-	2.69	2.69	2.68	-	3.00	3.00	3.00	-			
Amps	6.4	6.4	6.4	-	7.3	7.3	7.3	-	8.3	8.3	8.3	-	9.4	9.4	9.4	-	10.6	10.6	10.6	-	12.1	12.1	12.1	-			
HI PR	252	253	254	-	291	292	294	-	332	333	335	-	377	378	379	-	425	426	427	-	476	477	478	-			
LO PR	125	127	130	-	133	135	138	-	140	141	144	-	145	147	150	-	151	152	155	-	157	159	162	-			
MBh	30.1	30.6	31.4	-	29.9	30.3	31.2	-	29.1	29.5	30.4	-	27.8	28.2	29.1	-	26.2	26.6	27.5	-	24.7	25.1	26.0	-			
S/T	0.68	0.61	0.48	-	0.69	0.61	0.48	-	0.71	0.64	0.51	-	1.00	0.66	0.53	-	1.00	0.68	0.55	-	1.00	0.73	0.60	-			
ΔT	18	16	13	-	18	16	12	-	18	16	13	-	18	16	12	-	17	16	12	-	19	17	13	-			
KW	1.78	1.77	1.77	-	1.97	1.97	1.97	-	2.19	2.19	2.19	-	2.43	2.43	2.43	-	2.70	2.70	2.69	-	3.01	3.01	3.01	-			
Amps	6.5	6.5	6.4	-	7.4	7.4	7.3	-	8.4	8.4	8.3	-	9.5	9.5	9.4	-	10.7	10.7	10.7	-	12.1	12.1	12.1	-			
HI PR	254	255	257	-	293	294	296	-	334	335	337	-	379	380	382	-	427	428	429	-	478	479	481	-			
LO PR	128	129	132	-	135	137	140	-	142	143	146	-	147	149	152	-	153	154	157	-	160	161	164	-			
75	875	MBh	29.7	29.7	30.6	31.9	29.1	29.5	30.3	31.7	28.3	28.7	29.6	30.9	27.0	27.4	28.3	29.6	25.4	25.8	26.7	28.0	23.9	24.3	25.2	26.5	
		S/T	0.72	0.64	0.51	0.37	0.72	0.65	0.52	0.38	1.00	0.67	0.54	0.40	1.00	0.69	0.56	0.42	1.00	0.71	0.58	0.44	1.00	1.00	0.63	0.49	
		ΔT	24	22	19	15	24	22	19	15	24	22	19	15	24	22	19	15	24	22	18	15	25	25	23	19	16
		KW	1.76	1.75	1.75	1.77	1.95	1.95	1.95	1.96	2.17	2.17	2.17	2.18	2.41	2.41	2.41	2.42	2.68	2.68	2.67	2.69	2.99	2.99	2.99	3.00	3.00
		Amps	6.4	6.4	6.3	6.4	7.3	7.3	7.2	7.3	8.3	8.3	8.3	8.3	9.4	9.4	9.3	9.4	10.6	10.6	10.6	10.6	12.0	12.0	12.0	12.1	12.1
	HI PR	250	251	253	257	289	290	292	296	330	331	333	338	375	376	378	382	423	424	425	430	474	475	477	481	481	
	LO PR	124	125	128	134	131	133	136	141	138	139	142	148	143	145	148	153	149	150	154	159	156	157	160	166	166	
	MBh	29.7	30.1	31.0	32.3	29.4	29.9	30.7	32.1	28.7	29.1	30.0	31.3	27.4	27.8	28.6	30.0	25.8	26.2	27.0	28.4	24.3	24.7	25.6	26.9		
	S/T	0.78	0.70	0.57	0.43	0.78	0.71	0.58	0.44	1.00	0.73	0.60	0.46	1.00	0.75	0.62	0.48	1.00	0.77	0.64	0.50	1.00	1.00	0.69	0.55		
	ΔT	23	21	17	14	23	21	17	14	23	21	18	14	23	21	17	14	22	21	17	14	24	22	18	15	15	
KW	1.77	1.76	1.76	1.78	1.96	1.96	1.96	1.97	2.18	2.18	2.18	2.19	2.42	2.42	2.42	2.43	2.69	2.69	2.68	2.70	3.00	3.00	3.00	3.01	3.01		
Amps	6.4	6.4	6.4	6.5	7.3	7.3	7.3	7.4	8.3	8.3	8.3	8.4	9.4	9.4	9.4	9.5	10.6	10.6	10.6	10.7	12.1	12.1	12.0	12.1	12.1		
HI PR	252	253	255	259	291	292	294	298	332	334	335	340	377	378	380	384	425	426	428	432	476	477	479	483	483		
LO PR	126	127	130	135	133	135	138	143	140	141	144	150	145	147	150	155	151	152	155	161	158	159	162	167	167		
MBh	30.2	30.6	31.5	32.8	29.9	30.3	31.2	32.5	29.1	29.6	30.4	31.8	27.8	28.2	29.1	30.4	26.2	26.6	27.5	28.8	24.7	25.2	26.0	27.4			
S/T	0.81	0.73	0.60	0.46	1.00	0.74	0.61	0.47	1.00	0.77	0.63	0.49	1.00	0.78	0.65	0.51	1.00	0.81	0.67	0.53	1.00	1.00	0.72	0.58			
ΔT	22	20	17	13	22	20	17	13	22	20	17	13	22	20	16	13	21	20	16	13	23	21	17	14	14		
KW	1.77	1.77	1.77	1.78	1.97	1.97	1.97	1.98	2.19	2.19	2.19	2.20	2.43	2.43	2.43	2.44	2.70	2.70	2.69	2.71	3.01	3.01	3.00	3.02	3.02		
Amps	6.5	6.4	6.4	6.5	7.4	7.4	7.3	7.4	8.4	8.4	8.3	8.4	9.5	9.5	9.4	9.5	10.7	10.7	10.7	10.7	12.1	12.1	12.1	12.2	12.2		
HI PR	254	255	257	261	293	294	296	300	335	336	337	342	379	380	382	386	427	428	430	434	478	479	481	485	485		
LO PR	128	129	132	137	135	137	140	145	142	143	146	152	147	149	152	157	153	154	157	163	160	161	164	169	169		

IDB: Entering Indoor Dry Bulb Temperature
 High and low pressures are measured at the liquid and suction service valves.
 Shaded area reflects ACCA (TVA) conditions
 kW = Total system power
 Amps = outdoor unit amps (comp.+fan)

IDB	AIRFLOW	OUTDOOR AMBIENT TEMPERATURE												ENTERING INDOOR WET BULB TEMPERATURE											
		65				75				85				95				105				115			
		59	63	67	71	59	63	67	71	59	63	67	71	59	63	67	71	59	63	67	71	59	63	67	71
80	MBh	29.5	29.9	30.8	32.1	29.2	29.6	30.5	31.8	28.4	28.9	29.7	31.1	27.1	27.5	28.4	29.8	25.5	25.9	26.8	28.1	24.0	24.5	25.3	26.7
	S/T	1.00	0.77	0.63	0.5	1.00	0.77	0.64	0.50	1.00	0.80	0.66	0.5	1.00	1.00	0.68	0.54	1.00	1.00	0.70	0.6	1.00	1.00	0.75	0.61
	ΔT	28	26	23	19	28	26	23	19	28	26	23	19	28	26	23	19	28	26	22	19	29	27	23	20
	KW	1.76	1.75	1.75	1.8	1.95	1.95	1.95	1.96	2.17	2.17	2.17	2.2	2.41	2.41	2.41	2.42	2.68	2.68	2.67	2.7	2.99	2.99	2.99	3.00
	Amps	6.4	6.4	6.3	6.4	7.3	7.3	7.3	7.3	8.3	8.3	8.3	8.3	9.4	9.4	9.4	9.4	10.6	10.6	10.6	10.6	12.0	12.0	12.0	12.1
HI PR	250	251	253	257	290	291	292	297	331	332	334	338	375	376	378	382	423	424	426	430	474	475	477	481	
LO PR	124	126	129	134	132	133	136	142	138	140	143	148	144	145	149	154	149	151	154	159	156	158	161	166	
875	MBh	29.9	30.3	31.1	32.5	29.6	30.0	30.9	32.2	28.8	29.2	30.1	31.5	27.5	27.9	28.8	30.1	25.9	26.3	27.2	28.5	24.4	24.8	25.7	27.1
	S/T	1.00	0.82	0.69	0.6	1.00	0.83	0.70	0.56	1.00	0.85	0.72	0.6	1.00	1.00	0.74	0.60	1.00	1.00	0.76	0.6	1.00	1.00	0.81	0.67
	ΔT	27	25	22	18	27	25	21	18	27	25	22	18	27	25	21	18	26	25	21	18	28	26	22	19
	KW	1.77	1.76	1.76	1.8	1.96	1.96	1.96	1.97	2.18	2.18	2.18	2.2	2.42	2.42	2.42	2.43	2.69	2.69	2.68	2.7	3.00	3.00	3.00	3.01
	Amps	6.4	6.4	6.4	6.5	7.3	7.3	7.3	7.4	8.3	8.3	8.3	8.4	9.4	9.4	9.4	9.5	10.6	10.6	10.6	10.7	12.1	12.1	12.0	12.1
HI PR	252	253	255	259	292	293	295	299	333	334	336	340	377	378	380	385	425	426	428	432	476	477	479	484	
LO PR	126	128	131	136	134	135	138	144	140	142	145	150	146	147	150	156	151	153	156	161	158	160	163	168	
1000	MBh	30.3	30.7	31.6	32.9	30.1	30.5	31.3	32.7	29.3	29.7	30.6	31.9	28.0	28.4	29.3	30.6	26.4	26.8	27.7	29.0	24.9	25.3	26.2	27.5
	S/T	1.00	0.86	0.72	0.6	1.00	0.86	0.73	0.59	1.00	0.89	0.76	0.6	1.00	1.00	0.77	0.63	1.00	1.00	0.80	0.7	1.00	1.00	0.85	0.71
	ΔT	26	24	21	17	26	24	21	17	26	24	21	17	26	24	21	17	26	24	20	17	27	25	21	18
	KW	1.78	1.77	1.77	1.8	1.97	1.97	1.97	1.98	2.19	2.19	2.19	2.2	2.43	2.43	2.43	2.44	2.70	2.70	2.69	2.7	3.01	3.01	3.01	3.02
	Amps	6.5	6.5	6.4	6.5	7.4	7.4	7.3	7.4	8.4	8.4	8.3	8.4	9.5	9.5	9.4	9.5	10.7	10.7	10.7	10.7	12.1	12.1	12.1	12.2
HI PR	254	255	257	262	294	295	297	301	335	336	338	342	379	380	382	387	427	428	430	434	478	479	481	486	
LO PR	128	130	133	138	136	137	140	146	142	144	147	152	148	149	152	158	153	155	158	163	160	162	165	170	

IDB	AIRFLOW	OUTDOOR AMBIENT TEMPERATURE												ENTERING INDOOR WET BULB TEMPERATURE											
		65				75				85				95				105				115			
		59	63	67	71	59	63	67	71	59	63	67	71	59	63	67	71	59	63	67	71	59	63	67	71
875	MBh	30.0	30.4	31.3	32.6	29.7	30.1	31.0	32.3	28.9	29.3	30.2	31.6	27.6	28.0	28.9	30.2	26.0	26.4	27.3	28.6	24.5	25.0	25.8	27.2
	S/T	1.00	0.86	0.73	0.59	1.00	0.87	0.74	0.60	1.00	1.00	0.76	0.62	1.00	1.00	0.78	0.64	1.00	1.00	0.80	0.66	1.00	1.00	1.00	0.71
	ΔT	31	30	26	23	31	30	26	23	32	30	26	23	31	30	26	23	31	29	26	22	32	30	27	24
	KW	1.76	1.76	1.76	1.77	1.96	1.96	1.95	1.97	2.18	2.18	2.17	2.19	2.42	2.41	2.41	2.43	2.68	2.68	2.68	2.69	3.00	2.99	2.99	3.01
	Amps	6.4	6.4	6.4	6.4	7.3	7.3	7.3	7.3	8.3	8.3	8.3	8.3	9.4	9.4	9.4	9.4	10.6	10.6	10.6	10.7	12.0	12.0	12.0	12.1
HI PR	251	252	254	259	291	292	294	298	332	333	335	339	376	377	379	384	424	425	427	431	475	476	478	483	
LO PR	126	128	131	136	134	135	138	144	140	142	145	150	146	147	150	156	151	153	156	161	158	160	163	168	
1000	MBh	30.0	31.0	32.0	33.0	30.0	30.0	31.0	33.0	29.0	30.0	31.0	32.0	28.0	28.0	29.0	31.0	26.0	27.0	28.0	29.0	25.0	25.0	26.0	28.0
	S/T	1.00	0.92	0.79	0.65	1.00	1.00	0.80	0.66	1.00	1.00	0.82	0.68	1.00	1.00	0.84	0.70	1.00	1.00	0.86	0.72	1.00	1.00	1.00	0.77
	ΔT	30	29	25	22	30	29	25	22	31	29	25	22	30	28	25	22	30	28	25	21	31	29	26	22
	KW	1.77	1.77	1.77	1.78	1.97	1.97	1.96	1.98	2.19	2.19	2.18	2.20	2.43	2.42	2.42	2.44	2.69	2.69	2.69	2.70	3.01	3.00	3.00	3.02
	Amps	6.4	6.4	6.4	6.5	7.3	7.3	7.3	7.4	8.3	8.3	8.3	8.4	9.4	9.4	9.4	9.5	10.7	10.7	10.6	10.7	12.1	12.1	12.1	12.1
HI PR	253	255	256	261	293	294	296	300	334	335	337	341	379	380	381	386	426	427	429	434	477	479	480	485	
LO PR	128	129	133	138	135	137	140	145	142	144	147	152	148	149	152	158	153	155	158	163	160	161	165	170	
1125	MBh	31.0	31.0	32.0	33.0	31.0	31.0	32.0	33.0	30.0	30.0	31.0	32.0	28.0	29.0	30.0	31.0	27.0	27.0	28.0	29.0	25.0	26.0	27.0	28.0
	S/T	1.00	0.96	0.82	0.68	1.00	1.00	0.83	0.69	1.00	1.00	0.85	0.71	1.00	1.00	0.87	0.73	1.00	1.00	0.90	0.76	1.00	1.00	1.00	0.81
	ΔT	29	28	24	21	29	28	24	21	30	28	24	21	29	28	24	21	29	27	24	20	30	28	25	22
	KW	1.78	1.78	1.77	1.79	1.98	1.97	1.97	1.99	2.20	2.20	2.19	2.21	2.44	2.43	2.43	2.45	2.70	2.70	2.70	2.71	3.01	3.01	3.01	3.02
	Amps	6.5	6.5	6.5	6.5	7.4	7.4	7.4	7.4	8.4	8.4	8.4	8.4	9.5	9.5	9.5	9.5	10.7	10.7	10.7	10.7	12.1	12.1	12.1	12.2
HI PR	256	257	258	263	295	296	298	302	336	337	339	343	381	382	383	388	428	430	431	436	480	481	482	487	
LO PR	130	131	135	140	137	139	142	147	144	146	149	154	150	151	154	160	155	157	160	165	162	163	167	172	

IDB: Entering Indoor Dry Bulb Temperature
 High and low pressures are measured at the liquid and suction service valves.
 Shaded area reflects AHRI conditions
 kW = Total system power
 Amps = outdoor unit amps (comp.+fan)

IDB		OUTDOOR AMBIENT TEMPERATURE												ENTERING INDOOR WET BULB TEMPERATURE																							
		65						75						85						95						105						115					
		59	63	67	71	75	79	59	63	67	71	75	79	59	63	67	71	75	79	59	63	67	71	75	79	59	63	67	71	75	79	59	63	67	71	75	79
70	AIRFLOW	MBh	29.1	29.5	30.4	-	28.8	29.2	30.1	-	28.1	28.5	29.4	-	26.8	27.2	28.0	-	25.2	25.6	26.5	-	23.7	24.1	25.0	-	23.7	24.1	25.0	-	23.7	24.1	25.0	-			
	S/T	ΔT	0.63	0.55	0.41	-	0.63	0.56	0.42	-	0.66	0.58	0.44	-	0.68	0.60	0.46	-	1.00	0.62	0.48	-	1.00	0.68	0.54	-	1.00	0.68	0.54	-	1.00	0.68	0.54	-			
	KW	ΔT	1.72	1.72	1.72	-	1.91	1.91	1.91	-	2.13	2.12	2.12	-	2.36	2.35	2.35	-	2.61	2.61	2.61	-	2.92	2.92	2.91	-	2.92	2.92	2.91	-	2.92	2.92	2.91	-			
	Amps	HI PR	244	245	247	-	282	283	285	-	323	324	325	-	366	367	369	-	413	414	416	-	463	464	466	-	463	464	466	-	463	464	466	-			
	LO PR	LO PR	123	124	127	-	130	132	135	-	137	138	141	-	142	144	147	-	148	149	152	-	154	156	159	-	154	156	159	-	154	156	159	-			
	MBh	S/T	0.69	0.61	0.47	-	0.70	0.62	0.48	-	0.72	0.64	0.50	-	1.00	0.66	0.52	-	1.00	0.69	0.55	-	1.00	0.74	0.60	-	1.00	0.74	0.60	-	1.00	0.74	0.60	-			
	ΔT	ΔT	1.73	1.73	1.73	-	1.92	1.92	1.92	-	2.14	2.13	2.13	-	2.37	2.36	2.36	-	2.62	2.62	2.62	-	2.93	2.93	2.92	-	2.93	2.93	2.92	-	2.93	2.93	2.92	-			
	Amps	HI PR	246	247	249	-	284	286	287	-	325	326	328	-	368	369	371	-	415	416	418	-	465	466	468	-	465	466	468	-	465	466	468	-			
	LO PR	LO PR	124	126	129	-	132	133	136	-	138	140	143	-	144	145	149	-	149	151	154	-	156	158	161	-	156	158	161	-	156	158	161	-			
	MBh	S/T	0.73	0.65	0.51	-	0.73	0.65	0.51	-	0.76	0.68	0.54	-	1.00	0.70	0.56	-	1.00	0.72	0.58	-	1.00	0.78	0.63	-	1.00	0.78	0.63	-	1.00	0.78	0.63	-			
	ΔT	ΔT	1.74	1.74	1.73	-	1.93	1.93	1.92	-	2.14	2.14	2.14	-	2.37	2.37	2.37	-	2.63	2.63	2.63	-	2.94	2.93	2.93	-	2.94	2.93	2.93	-	2.94	2.93	2.93	-			
	Amps	HI PR	248	249	251	-	286	288	289	-	327	328	330	-	370	371	373	-	417	418	420	-	467	468	470	-	467	468	470	-	467	468	470	-			
	LO PR	LO PR	126	128	131	-	134	135	138	-	140	142	145	-	146	147	151	-	151	153	156	-	158	160	163	-	158	160	163	-	158	160	163	-			
75	AIRFLOW	MBh	29.1	29.5	30.4	31.7	28.9	29.3	30.1	31.0	28.9	29.3	30.2	31.5	28.1	28.5	29.4	30.7	26.8	27.2	28.1	29.4	25.2	25.6	26.5	27.8	23.7	24.1	25.0	26.3	23.7	24.1	25.0	26.3			
	S/T	ΔT	0.76	0.68	0.54	0.39	0.77	0.69	0.55	0.40	0.76	0.68	0.54	0.40	1.00	0.72	0.57	0.43	1.00	0.74	0.60	0.45	1.00	0.76	0.62	0.47	1.00	1.00	0.67	0.52	1.00	1.00	0.67	0.52			
	KW	ΔT	1.72	1.72	1.71	1.73	1.91	1.91	1.91	1.92	2.12	2.12	2.13	2.14	2.12	2.12	2.12	2.13	2.14	2.36	2.35	2.35	2.36	2.61	2.61	2.61	2.62	2.92	2.92	2.91	2.93	2.92	2.92	2.91	2.93		
	Amps	HI PR	244	245	247	251	283	284	285	290	323	324	326	330	323	324	326	330	366	367	369	373	413	414	416	420	463	464	466	470	463	464	466	470			
	LO PR	LO PR	123	124	127	132	130	132	135	140	137	138	141	146	137	138	141	146	142	144	147	152	148	149	152	157	154	156	159	164	154	156	159	164			
	MBh	S/T	0.82	0.75	0.60	0.46	0.83	0.75	0.61	0.46	0.82	0.74	0.60	0.46	1.00	0.78	0.64	0.49	1.00	0.80	0.66	0.51	1.00	0.82	0.68	0.53	1.00	1.00	0.73	0.59	1.00	1.00	0.73	0.59			
	ΔT	ΔT	2.3	2.1	1.8	1.4	2.3	2.1	1.8	1.4	2.3	2.2	1.8	1.4	2.3	2.2	1.8	1.4	2.3	2.1	1.8	1.4	2.3	2.1	1.8	1.4	2.4	2.2	1.9	1.5	2.4	2.2	1.9	1.5			
	KW	ΔT	1.73	1.73	1.72	1.74	1.92	1.92	1.92	1.93	2.13	2.13	2.14	2.15	2.13	2.13	2.13	2.14	2.37	2.36	2.36	2.37	2.62	2.62	2.62	2.63	2.93	2.92	2.92	2.94	2.93	2.92	2.92	2.94			
	Amps	HI PR	246	247	249	253	285	286	287	292	325	326	328	332	325	326	328	332	368	369	371	375	415	416	418	422	465	466	468	472	465	466	468	472			
	LO PR	LO PR	124	126	129	134	132	133	137	142	138	140	143	148	138	140	143	148	144	145	149	154	149	151	154	159	156	158	161	166	156	158	161	166			
	MBh	S/T	0.86	0.78	0.64	0.49	0.86	0.78	0.65	0.50	0.85	0.77	0.63	0.49	1.00	0.81	0.67	0.52	1.00	0.83	0.69	0.54	1.00	0.86	0.72	0.57	1.00	1.00	0.77	0.62	1.00	1.00	0.77	0.62			
	ΔT	ΔT	2.2	2.0	1.7	1.3	2.2	2.0	1.7	1.3	2.2	2.1	1.7	1.3	2.2	2.1	1.7	1.3	2.2	2.0	1.7	1.3	2.2	2.0	1.7	1.3	2.3	2.1	1.8	1.4	2.3	2.1	1.8	1.4			
	KW	ΔT	1.74	1.74	1.73	1.75	1.93	1.93	1.92	1.94	2.14	2.14	2.15	2.15	2.14	2.14	2.14	2.15	2.37	2.37	2.37	2.38	2.63	2.63	2.63	2.64	2.93	2.93	2.93	2.94	2.93	2.93	2.93	2.94			
	Amps	HI PR	248	249	251	255	287	288	289	294	327	328	330	334	327	328	330	334	370	371	373	377	417	418	420	424	467	468	470	474	467	468	470	474			
	LO PR	LO PR	126	128	131	136	134	135	139	144	140	142	145	150	140	142	145	150	146	147	151	156	151	153	156	161	158	160	163	168	158	160	163	168			

IDB: Entering Indoor Dry Bulb Temperature
 High and low pressures are measured at the liquid and suction service valves.
 Shaded area reflects ACCA (TVA) conditions
 kW = Total system power
 Amps = outdoor unit amps (comp.+fan)

IDB	AIRFLOW	OUTDOOR AMBIENT TEMPERATURE												ENTERING INDOOR WET BULB TEMPERATURE											
		65				75				85				95				105				115			
		59	63	67	71	59	63	67	71	59	63	67	71	59	63	67	71	59	63	67	71	59	63	67	71
80	MBh	29.3	29.7	30.5	31.9	29.0	29.4	30.3	31.6	28.2	28.7	29.5	30.9	26.9	27.3	28.2	29.5	25.3	25.8	26.6	27.9	23.9	24.3	25.2	26.5
	S/T	1.00	0.81	0.67	0.5	1.00	0.82	0.68	0.53	1.00	0.85	0.70	0.6	1.00	0.87	0.73	0.58	1.00	1.00	0.75	0.6	1.00	1.00	0.80	0.65
	ΔT	28	27	23	19	28	27	23	19	29	27	23	20	28	27	23	19	28	26	23	19	29	27	24	20
	KW	1.72	1.72	1.72	1.7	1.91	1.91	1.91	1.92	2.12	2.12	2.12	2.1	2.36	2.35	2.35	2.37	2.61	2.61	2.61	2.6	2.92	2.92	2.91	2.93
	Amps	6.2	6.2	6.2	6.2	7.1	7.1	7.1	7.1	8.1	8.0	8.0	8.1	9.1	9.1	9.1	9.2	10.3	10.3	10.3	10.3	11.7	11.7	11.7	11.7
	HI PR	245	246	247	252	283	284	286	290	323	324	326	330	367	368	370	374	414	415	416	421	464	465	466	471
	LO PR	123	125	128	133	131	132	135	140	137	139	142	147	143	144	147	153	148	150	153	158	155	156	160	165
875	MBh	29.6	30.1	30.9	32.3	29.4	29.8	30.7	32.0	28.6	29.0	29.9	31.2	27.3	27.7	28.6	29.9	25.7	26.1	27.0	28.3	24.3	24.7	25.5	26.9
	S/T	1.00	0.88	0.73	0.6	1.00	0.88	0.74	0.59	1.00	0.91	0.77	0.6	1.00	1.00	0.79	0.64	1.00	1.00	0.81	0.7	1.00	1.00	0.86	0.72
	ΔT	27	25	22	18	27	25	22	18	28	26	22	19	27	25	22	18	27	25	22	18	28	26	23	19
	KW	1.73	1.73	1.72	1.7	1.92	1.92	1.92	1.93	2.13	2.13	2.13	2.1	2.37	2.36	2.36	2.38	2.62	2.62	2.62	2.6	2.93	2.93	2.92	2.94
	Amps	6.2	6.2	6.2	6.3	7.1	7.1	7.1	7.2	8.1	8.1	8.1	8.1	9.2	9.2	9.2	9.2	10.3	10.3	10.3	10.4	11.7	11.7	11.7	11.8
	HI PR	247	248	249	254	285	286	288	292	325	326	328	332	369	370	372	376	416	417	418	423	466	467	468	473
	LO PR	125	126	130	135	132	134	137	142	139	140	144	149	144	146	149	154	150	151	155	160	157	158	161	167
1000	MBh	30.1	30.5	31.4	32.7	29.8	30.3	31.1	32.5	29.1	29.5	30.4	31.7	27.8	28.2	29.1	30.4	26.2	26.6	27.5	28.8	24.7	25.1	26.0	27.3
	S/T	1.00	0.91	0.77	0.6	1.00	0.92	0.78	0.63	1.00	0.94	0.80	0.7	1.00	1.00	0.82	0.67	1.00	1.00	0.85	0.7	1.00	1.00	0.90	0.75
	ΔT	26	25	21	17	26	24	21	17	27	25	21	18	26	24	21	17	26	24	21	17	27	25	22	18
	KW	1.74	1.74	1.73	1.8	1.93	1.93	1.92	1.94	2.14	2.14	2.14	2.2	2.37	2.37	2.37	2.38	2.63	2.63	2.63	2.6	2.94	2.93	2.93	2.95
	Amps	6.3	6.3	6.3	6.3	7.2	7.2	7.1	7.2	8.1	8.1	8.1	8.2	9.2	9.2	9.2	9.2	10.4	10.4	10.4	10.4	11.8	11.8	11.7	11.8
	HI PR	249	250	251	256	287	288	290	294	327	328	330	334	371	372	374	378	418	419	420	425	468	469	470	475
	LO PR	127	128	132	137	134	136	139	144	141	142	146	151	146	148	151	156	152	153	157	162	159	160	163	169

IDB	AIRFLOW	OUTDOOR AMBIENT TEMPERATURE												ENTERING INDOOR WET BULB TEMPERATURE											
		65				75				85				95				105				115			
		59	63	67	71	59	63	67	71	59	63	67	71	59	63	67	71	59	63	67	71	59	63	67	71
875	MBh	29.8	30.2	31.0	32.4	29.5	29.9	30.8	32.1	28.7	29.1	30.0	31.3	27.4	27.8	28.7	30.0	25.8	26.2	27.1	28.4	24.4	24.8	25.7	27.0
	S/T	1.00	0.92	0.78	0.63	1.00	0.92	0.78	0.64	1.00	1.00	0.81	0.66	1.00	1.00	0.83	0.68	1.00	1.00	0.85	0.70	1.00	1.00	1.00	0.76
	ΔT	32	30	27	23	32	30	27	23	32	30	27	23	32	30	27	23	32	30	26	23	33	31	28	24
	KW	1.72	1.72	1.72	1.73	1.91	1.91	1.91	1.92	2.13	2.13	2.12	2.14	2.36	2.36	2.36	2.37	2.62	2.62	2.61	2.63	2.92	2.92	2.92	2.93
	Amps	6.2	6.2	6.2	6.3	7.1	7.1	7.1	7.1	8.1	8.1	8.0	8.1	9.1	9.1	9.1	9.2	10.3	10.3	10.3	10.4	11.7	11.7	11.7	11.7
	HI PR	246	247	248	253	284	285	287	291	325	326	327	332	368	369	371	375	415	416	417	422	465	466	467	472
	LO PR	125	127	130	135	132	134	137	142	139	141	144	149	145	146	149	154	150	151	155	160	157	158	161	167
1000	MBh	30.1	30.5	31.4	32.7	29.9	30.3	31.2	32.5	29.1	29.5	30.4	31.7	27.8	28.2	29.1	30.4	26.2	26.6	27.5	28.8	24.8	25.2	26.0	27.4
	S/T	1.00	0.98	0.84	0.69	1.00	1.00	0.85	0.70	1.00	1.00	0.87	0.72	1.00	1.00	0.89	0.74	1.00	1.00	0.92	0.77	1.00	1.00	1.00	0.82
	ΔT	31	29	26	22	31	29	26	22	31	29	26	22	31	29	26	22	31	29	25	22	32	30	26	23
	KW	1.73	1.73	1.73	1.74	1.92	1.92	1.92	1.93	2.14	2.14	2.13	2.15	2.37	2.37	2.36	2.38	2.63	2.63	2.62	2.64	2.93	2.93	2.93	2.94
	Amps	6.3	6.3	6.2	6.3	7.1	7.1	7.1	7.2	8.1	8.1	8.1	8.2	9.2	9.2	9.2	9.2	10.4	10.4	10.3	10.4	11.7	11.7	11.7	11.8
	HI PR	248	249	251	255	286	287	289	293	327	328	329	334	370	371	373	377	417	418	420	424	467	468	470	474
	LO PR	127	128	131	137	134	136	139	144	141	142	145	151	146	148	151	156	152	153	156	162	159	160	163	168
1125	MBh	30.6	31.0	31.9	33.2	30.3	30.7	31.6	32.9	29.6	30.0	30.9	32.2	28.3	28.7	29.5	30.9	26.7	27.1	28.0	29.3	25.2	25.6	26.5	27.8
	S/T	1.00	1.00	0.87	0.73	1.00	1.00	0.88	0.73	1.00	1.00	0.91	0.76	1.00	1.00	0.93	0.78	1.00	1.00	0.92	0.80	1.00	1.00	1.00	0.86
	ΔT	30	28	25	21	30	28	25	21	30	28	25	21	30	28	25	21	30	28	24	21	31	29	26	22
	KW	1.74	1.74	1.74	1.75	1.93	1.93	1.93	1.94	2.15	2.15	2.14	2.16	2.38	2.38	2.37	2.39	2.64	2.63	2.63	2.65	2.94	2.94	2.93	2.95
	Amps	6.3	6.3	6.3	6.3	7.2	7.2	7.2	7.2	8.2	8.1	8.1	8.2	9.2	9.2	9.2	9.3	10.4	10.4	10.4	10.4	11.8	11.8	11.8	11.8
	HI PR	250	251	253	257	288	289	291	295	329	330	331	336	372	373	375	379	419	420	422	426	469	470	472	476
	LO PR	129	130	133	139	136	138	141	146	143	144	147	153	148	150	153	158	154	155	158	164	161	162	165	170

IDB: Entering Indoor Dry Bulb Temperature
 High and low pressures are measured at the liquid and suction service valves.
 Shaded area reflects AHRI conditions
 kW = Total system power
 Amps = outdoor unit amps (comp.+fan)

IDB	AIRFLOW	OUTDOOR AMBIENT TEMPERATURE												ENTERING INDOOR WET BULB TEMPERATURE											
		65				75				85				95				105				115			
		59	63	67	71	59	63	67	71	59	63	67	71	59	63	67	71	59	63	67	71	59	63	67	71
70	MBh	34.8	35.3	36.3	-	34.5	35.0	36.0	-	33.6	34.1	35.1	-	32.0	32.5	33.5	-	30.1	30.6	31.6	-	28.4	28.8	29.9	-
	S/T	0.59	0.52	0.38	-	0.60	0.52	0.39	-	0.62	0.55	0.42	-	0.64	0.57	0.43	-	1.00	0.59	0.46	-	1.00	0.64	0.51	-
	ΔT	19	17	14	-	19	17	14	-	19	18	14	-	19	17	14	-	19	17	14	-	20	18	15	-
	KW	2.09	2.09	2.09	-	2.32	2.32	2.32	-	2.58	2.58	2.58	-	2.87	2.86	2.86	-	3.18	3.18	3.17	-	3.55	3.55	3.54	-
	Amps	7.6	7.6	7.5	-	8.6	8.6	8.6	-	9.8	9.8	9.8	-	11.1	11.1	11.1	-	12.5	12.5	12.5	-	14.2	14.2	14.2	-
1050	HI PR	254	255	257	-	294	295	297	-	336	337	339	-	381	382	384	-	430	431	433	-	482	483	485	-
	LO PR	121	123	126	-	129	130	133	-	135	137	140	-	141	142	145	-	146	147	151	-	153	154	157	-
	MBh	35.3	35.7	36.8	-	34.9	35.4	36.5	-	34.0	34.5	35.6	-	32.5	33.0	34.0	-	30.6	31.0	32.1	-	28.8	29.3	30.3	-
	S/T	0.65	0.58	0.44	-	0.66	0.58	0.45	-	0.68	0.61	0.47	-	0.70	0.63	0.49	-	1.00	0.65	0.51	-	1.00	0.70	0.56	-
	ΔT	18	16	13	-	18	16	13	-	18	17	13	-	18	16	13	-	18	16	13	-	19	17	14	-
1200	KW	2.10	2.10	2.10	-	2.34	2.33	2.33	-	2.60	2.59	2.59	-	2.88	2.88	2.87	-	3.19	3.19	3.19	-	3.56	3.56	3.55	-
	Amps	7.6	7.6	7.6	-	8.7	8.7	8.7	-	9.9	9.9	9.9	-	11.2	11.2	11.1	-	12.6	12.6	12.6	-	14.3	14.3	14.3	-
	HI PR	256	257	259	-	296	297	299	-	338	339	341	-	384	385	386	-	432	433	435	-	484	485	487	-
	LO PR	123	125	128	-	130	132	135	-	137	138	141	-	142	144	147	-	148	149	152	-	154	156	159	-
	MBh	35.8	36.3	37.3	-	35.5	36.0	37.0	-	34.6	35.1	36.1	-	33.0	33.5	34.5	-	31.1	31.6	32.6	-	29.4	29.9	30.9	-
1350	S/T	0.68	0.61	0.48	-	0.69	0.61	0.48	-	0.71	0.64	0.51	-	1.00	0.66	0.53	-	1.00	0.68	0.55	-	1.00	0.73	0.60	-
	ΔT	17	15	12	-	17	15	12	-	17	16	12	-	17	15	12	-	17	15	12	-	18	16	13	-
	KW	2.11	2.11	2.11	-	2.35	2.34	2.34	-	2.61	2.60	2.60	-	2.89	2.89	2.88	-	3.20	3.20	3.20	-	3.57	3.57	3.56	-
	Amps	7.7	7.7	7.6	-	8.7	8.7	8.7	-	9.9	9.9	9.9	-	11.2	11.2	11.2	-	12.7	12.6	12.6	-	14.3	14.3	14.3	-
	HI PR	258	259	261	-	298	300	301	-	340	342	343	-	386	387	389	-	434	435	437	-	486	488	489	-
LO PR	125	127	130	-	132	134	137	-	139	140	143	-	144	146	149	-	150	151	154	-	156	158	161	-	
75	MBh	34.8	35.3	36.3	37.9	34.5	35.0	36.0	37.6	33.6	34.1	35.1	36.7	32.0	32.5	33.6	35.2	30.1	30.6	31.7	33.2	28.4	28.9	29.9	31.5
	S/T	0.72	0.64	0.51	0.37	0.72	0.65	0.52	0.38	1.00	0.67	0.54	0.40	1.00	0.69	0.56	0.42	1.00	0.71	0.58	0.44	1.00	0.76	0.63	0.49
	ΔT	23	21	18	15	23	21	18	15	23	22	18	15	23	21	18	15	23	21	18	14	24	22	19	15
	KW	2.09	2.09	2.08	2.10	2.32	2.32	2.32	2.33	2.58	2.58	2.58	2.59	2.86	2.86	2.86	2.88	3.18	3.18	3.17	3.19	3.55	3.54	3.54	3.56
	Amps	7.6	7.6	7.5	8.0	8.6	8.6	8.6	8.7	9.8	9.8	9.8	10.0	11.1	11.1	11.1	11.2	12.5	12.5	12.5	13.0	14.2	14.2	14.2	14.3
1050	HI PR	254	255	257	262	294	295	297	302	336	337	339	344	382	383	384	389	430	431	433	438	482	484	485	490
	LO PR	121	123	126	131	129	130	133	138	135	137	140	145	141	142	145	150	146	147	151	156	153	154	157	162
	MBh	35.3	35.8	36.8	38.4	35.0	35.5	36.5	38.1	34.1	34.5	35.6	37.2	32.5	33.0	34.0	35.6	30.6	31.1	32.1	33.7	28.8	29.3	30.4	32.0
	S/T	0.78	0.70	0.57	0.43	0.78	0.71	0.58	0.44	1.00	0.73	0.60	0.46	1.00	0.75	0.62	0.48	1.00	0.77	0.64	0.50	1.00	1.00	0.69	0.55
	ΔT	22	20	17	14	22	20	17	13	22	20	17	14	22	20	17	13	22	20	17	13	23	21	18	14
1200	KW	2.10	2.10	2.10	2.11	2.33	2.33	2.33	2.35	2.59	2.59	2.59	2.61	2.88	2.87	2.87	2.89	3.19	3.19	3.18	3.20	3.56	3.56	3.55	3.57
	Amps	7.6	7.6	7.6	8.0	8.7	8.7	8.7	9.0	9.9	9.9	9.8	10.0	11.2	11.1	11.1	11.0	12.6	12.6	12.6	13.0	14.3	14.3	14.3	14.0
	HI PR	256	258	259	264	297	298	299	304	339	340	341	346	384	385	387	391	433	434	435	440	485	486	487	492
	LO PR	123	125	128	133	130	132	135	140	137	138	141	147	142	144	147	152	148	149	152	157	154	156	159	164
	MBh	35.8	36.3	37.4	38.9	35.5	36.0	37.0	38.6	34.6	35.1	36.1	37.7	33.0	33.5	34.6	36.2	31.1	31.6	32.7	34.2	29.4	29.9	30.9	32.5
1350	S/T	0.81	0.73	0.60	0.46	0.82	0.74	0.61	0.47	1.00	0.77	0.63	0.49	1.00	0.78	0.65	0.51	1.00	0.81	0.67	0.53	1.00	1.00	0.72	0.58
	ΔT	21	19	16	13	21	19	16	13	21	20	16	13	21	19	16	13	21	19	16	12	22	20	17	13
	KW	2.11	2.11	2.11	2.12	2.34	2.34	2.34	2.36	2.60	2.60	2.60	2.62	2.89	2.88	2.88	2.90	3.20	3.20	3.19	3.21	3.57	3.57	3.56	3.58
	Amps	7.7	7.7	7.6	8.0	8.7	8.7	8.7	9.0	9.9	9.9	9.9	10.0	11.2	11.2	11.2	11.0	12.6	12.6	12.6	13.0	14.3	14.3	14.3	14.0
	HI PR	259	260	261	266	299	300	302	306	341	342	344	348	386	387	389	393	435	436	438	442	487	488	490	494
LO PR	125	127	130	135	132	134	137	142	139	140	143	149	144	146	149	154	150	151	154	159	156	158	161	166	

IDB: Entering Indoor Dry Bulb Temperature
 High and low pressures are measured at the liquid and suction service valves.
 Shaded area reflects ACCA (TVA) conditions
 kW = Total system power
 Amps = outdoor unit amps (comp.+fan)

IDB		OUTDOOR AMBIENT TEMPERATURE														ENTERING INDOOR WET BULB TEMPERATURE																																																																																				
		65							75							85							95							105							115																																																															
		59	63	67	71	75	79	83	59	63	67	71	75	79	83	59	63	67	71	75	79	83	59	63	67	71	75	79	83	59	63	67	71	75	79	83	59	63	67	71	75	79	83																																																									
1050	MBh	35.0	35.5	36.5	38.1	34.7	35.2	36.2	37.8	33.8	34.3	35.3	36.9	32.2	32.7	33.7	35.3	30.3	30.8	31.8	33.4	28.6	29.0	30.1	31.7	S/T	0.84	0.77	0.63	0.5	1.00	0.77	0.64	0.50	1.00	0.80	0.66	0.5	1.00	0.82	0.68	0.54	1.00	1.00	1.00	0.70	0.6	1.00	1.00	0.75	0.61	ΔT	2.09	2.09	2.09	2.1	2.32	2.32	2.32	2.34	2.58	2.58	2.58	2.6	2.86	2.86	2.86	2.88	3.18	3.18	3.18	3.17	3.2	3.55	3.55	3.54	3.56																							
1200	Amps	7.6	7.6	7.5	8.0	8.6	8.6	8.6	9.0	9.8	9.8	9.8	10.0	11.1	11.1	11.1	11.0	12.5	12.5	12.5	13.0	14.2	14.2	14.2	14.0	HI PR	255	256	258	262	295	296	298	302	337	338	340	344	382	383	385	389	431	432	434	438	483	484	486	490	LO PR	122	123	126	132	129	131	134	139	136	137	140	145	141	143	146	151	146	148	151	156	153	155	158	163																									
1350	MBh	35.5	35.9	37.0	38.6	35.1	35.6	36.7	38.3	34.2	34.7	35.8	37.4	32.7	33.2	34.2	35.8	30.8	31.2	32.3	33.9	29.0	29.5	30.5	32.1	S/T	1.00	0.82	0.69	0.6	1.00	0.83	0.70	0.56	1.00	0.85	0.72	0.6	1.00	0.87	0.74	0.60	1.00	1.00	1.00	0.76	0.6	1.00	1.00	0.81	0.67	ΔT	2.6	2.4	2.1	1.7	2.6	2.4	2.1	1.8	2.6	2.4	2.1	1.8	2.6	2.4	2.1	1.7	2.6	2.4	2.1	1.7	2.7	2.5	2.2	1.8																								
80	KW	2.10	2.10	2.10	2.1	2.34	2.33	2.33	2.35	2.60	2.59	2.59	2.6	2.88	2.87	2.87	2.89	3.19	3.19	3.19	3.2	3.56	3.56	3.55	3.57	Amps	7.6	7.6	7.6	8.0	8.7	8.7	8.7	9.0	9.9	9.9	9.9	10.0	11.2	11.2	11.1	11.0	12.6	12.6	12.6	13.0	14.3	14.3	14.3	14.0	HI PR	257	258	260	264	297	298	300	304	339	340	342	346	384	385	387	392	433	434	436	440	485	486	488	492	LO PR	124	125	128	133	131	132	136	141	137	139	142	147	143	144	147	153	148	150	153	158	155	156	160	165
85	MBh	36.0	36.5	37.5	39.1	35.7	36.2	37.2	38.8	34.8	35.3	36.3	37.9	33.2	33.7	34.7	36.3	31.3	31.8	32.8	34.4	29.6	30.1	31.1	32.7	S/T	1.00	0.86	0.72	0.6	1.00	0.86	0.73	0.59	1.00	0.89	0.76	0.6	1.00	1.00	0.77	0.63	1.00	1.00	1.00	0.80	0.7	1.00	1.00	0.85	0.71	ΔT	2.5	2.3	2.0	1.7	2.5	2.3	2.0	1.7	2.5	2.4	2.0	1.7	2.5	2.3	2.0	1.6	2.5	2.3	2.0	1.6	2.6	2.4	2.1	1.7																								
1050	KW	2.11	2.11	2.11	2.1	2.35	2.34	2.34	2.36	2.61	2.60	2.60	2.6	2.89	2.89	2.88	2.90	3.20	3.20	3.20	3.2	3.57	3.57	3.56	4.00	Amps	7.7	7.7	7.6	8.0	9.0	8.7	8.7	9.0	9.9	9.9	9.9	10.0	11.2	11.2	11.0	11.0	12.7	12.6	12.6	13.0	14.3	14.3	14.2	14.0	HI PR	256	257	259	263	296	297	299	303	338	339	341	345	383	384	386	391	432	433	435	439	484	485	487	491	LO PR	124	125	128	133	131	133	136	141	137	139	142	147	143	144	148	153	148	150	153	158	155	157	160	165
1200	MBh	36.0	36.5	37.6	39.2	35.7	36.2	37.3	38.8	34.8	35.3	36.3	37.9	33.3	33.7	34.8	36.4	31.3	31.8	32.9	34.5	29.6	30.1	31.1	32.7	S/T	1.00	0.92	0.79	0.65	1.00	0.93	0.80	0.66	1.00	1.00	0.82	0.68	1.00	1.00	0.84	0.70	1.00	1.00	1.00	0.86	0.72	1.00	1.00	0.80	0.77	ΔT	2.9	2.8	2.4	2.1	2.9	2.8	2.4	2.1	3.0	2.8	2.5	2.1	2.9	2.8	2.4	2.1	2.9	2.7	2.4	2.1	3.0	2.8	2.5	2.2																								
1350	KW	2.11	2.11	2.10	2.12	2.34	2.34	2.33	2.35	2.60	2.60	2.59	2.61	2.88	2.88	2.88	2.89	3.20	3.19	3.19	3.21	3.56	3.56	3.56	3.58	Amps	7.6	7.6	7.6	8.0	8.7	8.7	8.7	9.0	9.9	9.9	9.9	10.0	11.2	11.2	11.0	11.0	12.6	12.6	12.6	13.0	14.3	14.3	14.2	14.0	HI PR	258	259	261	265	298	299	301	306	340	341	343	348	385	387	388	393	434	435	437	442	486	487	489	494	LO PR	125	127	130	135	133	134	137	143	139	141	144	149	145	146	149	154	150	152	155	160	157	158	161	167
85	MBh	36.6	37.1	38.1	39.7	36.3	36.8	37.8	39.4	35.4	35.9	36.9	38.5	33.8	34.3	35.3	36.9	31.9	32.4	33.4	35.0	30.1	30.6	31.7	33.3	S/T	1.00	0.96	0.82	0.68	1.00	1.00	0.83	0.69	1.00	1.00	0.85	0.71	1.00	1.00	0.87	0.73	1.00	1.00	1.00	0.89	0.76	1.00	1.00	0.80	0.81	ΔT	2.9	2.7	2.3	2.0	2.9	2.7	2.3	2.0	2.9	2.7	2.4	2.0	2.8	2.7	2.3	2.0	2.8	2.6	2.3	2.0	2.9	2.8	2.4	2.1																								
1050	KW	2.12	2.12	2.11	2.13	2.35	2.35	2.34	2.36	2.61	2.61	2.60	2.62	2.89	2.89	2.89	2.90	3.21	3.20	3.20	3.22	3.57	3.57	3.57	3.59	Amps	7.7	7.7	7.7	8.0	8.8	8.7	8.7	9.0	9.9	9.9	9.9	10.0	11.2	11.2	11.0	11.0	12.7	12.7	12.6	13.0	14.4	14.3	14.2	14.0	HI PR	260	261	263	268	300	301	303	308	342	343	345	350	388	389	390	395	436	437	439	444	488	489	491	496	LO PR	127	129	132	137	135	136	139	145	141	143	146	151	147	148	151	156	152	154	157	162	159	160	163	169

IDB: Entering Indoor Dry Bulb Temperature
 High and low pressures are measured at the liquid and suction service valves.
 Shaded area reflects AHRI conditions
 kW = Total system power
 Amps = outdoor unit amps (comp.+fan)

IDB		OUTDOOR AMBIENT TEMPERATURE												ENTERING INDOOR WET BULB TEMPERATURE																							
		65						75						85						95						105						115					
		59	63	67	71	59	63	67	71	59	63	67	71	59	63	67	71	59	63	67	71	59	63	67	71	59	63	67	71	59	63	67	71				
1100	MBh	35.0	35.5	36.6	-	34.7	35.2	36.3	-	33.8	34.3	35.4	-	32.3	32.8	33.8	-	30.4	30.9	31.9	-	28.6	29.1	30.2	-	30.4	30.9	31.9	-	28.6	29.1	30.2	-				
	S/T	0.66	0.59	0.45	-	0.67	0.59	0.46	-	0.70	0.62	0.48	-	0.71	0.64	0.50	-	1.00	0.66	0.53	-	1.00	0.71	0.58	-	1.00	0.66	0.53	-	1.00	0.71	0.58	-				
	ΔT	2.0	18	14	-	2.0	18	14	-	2.0	18	14	-	1.9	18	14	-	1.9	17	14	-	2.0	19	15	-	1.9	17	14	-	2.0	19	15	-				
	KW	2.03	2.03	2.02	-	2.26	2.26	2.26	-	2.53	2.53	2.52	-	2.81	2.81	2.81	-	3.13	3.13	3.13	-	3.51	3.50	3.50	-	3.13	3.13	3.13	-	3.51	3.50	3.50	-				
	Amps	7.4	7.4	7.4	-	8.5	8.5	8.5	-	9.7	9.7	9.7	-	11.0	11.0	11.0	-	12.5	12.5	12.5	-	14.2	14.2	14.2	-	12.5	12.5	12.5	-	14.2	14.2	14.2	-				
1200	MBh	35.4	35.9	37.0	-	35.1	35.6	36.6	-	34.2	34.7	35.7	-	32.7	33.2	34.2	-	30.8	31.3	32.3	-	29.0	29.5	30.6	-	30.8	31.3	32.3	-	29.0	29.5	30.6	-				
	S/T	0.69	0.62	0.48	-	0.70	0.62	0.49	-	0.72	0.65	0.51	-	0.74	0.67	0.53	-	1.00	0.69	0.55	-	1.00	0.74	0.60	-	1.00	0.69	0.55	-	1.00	0.74	0.60	-				
	ΔT	1.9	17	13	-	1.9	17	13	-	1.9	17	14	-	1.9	17	13	-	1.9	17	13	-	2.0	18	14	-	1.9	17	13	-	2.0	18	14	-				
	KW	2.04	2.03	2.03	-	2.27	2.27	2.27	-	2.54	2.53	2.53	-	2.82	2.82	2.82	-	3.14	3.14	3.13	-	3.51	3.51	3.51	-	3.14	3.14	3.13	-	3.51	3.51	3.51	-				
	Amps	7.5	7.5	7.5	-	8.6	8.6	8.5	-	9.8	9.8	9.7	-	11.1	11.1	11.0	-	12.5	12.5	12.5	-	14.2	14.2	14.2	-	12.5	12.5	12.5	-	14.2	14.2	14.2	-				
1350	MBh	36.1	36.6	37.6	-	35.8	36.3	37.3	-	34.9	35.4	36.4	-	33.4	33.8	34.9	-	31.5	31.9	33.0	-	29.7	30.2	31.2	-	31.5	31.9	33.0	-	29.7	30.2	31.2	-				
	S/T	0.71	0.63	0.50	-	0.71	0.64	0.50	-	0.74	0.66	0.53	-	1.00	0.68	0.55	-	1.00	0.71	0.57	-	1.00	0.76	0.62	-	1.00	0.71	0.57	-	1.00	0.76	0.62	-				
	ΔT	1.8	16	12	-	1.8	16	12	-	1.8	16	13	-	1.8	16	12	-	1.8	16	12	-	1.9	17	13	-	1.8	16	12	-	1.9	17	13	-				
	KW	2.05	2.04	2.04	-	2.28	2.28	2.28	-	2.55	2.54	2.54	-	2.83	2.83	2.83	-	3.15	3.15	3.14	-	3.52	3.52	3.52	-	3.15	3.15	3.14	-	3.52	3.52	3.52	-				
	Amps	7.5	7.5	7.5	-	8.6	8.6	8.6	-	9.8	9.8	9.8	-	11.1	11.1	11.1	-	12.6	12.6	12.6	-	14.3	14.3	14.3	-	12.6	12.6	12.6	-	14.3	14.3	14.3	-				

IDB		OUTDOOR AMBIENT TEMPERATURE												ENTERING INDOOR WET BULB TEMPERATURE																							
		65						75						85						95						105						115					
		59	63	67	71	59	63	67	71	59	63	67	71	59	63	67	71	59	63	67	71	59	63	67	71	59	63	67	71	59	63	67	71				
1100	MBh	35.1	35.6	36.6	38.2	34.8	35.2	36.3	37.9	33.9	34.3	35.4	37.0	32.3	32.8	33.8	35.4	30.4	30.9	31.9	33.5	28.7	29.2	30.2	31.8	30.4	30.9	31.9	33.5	28.7	29.2	30.2	31.8				
	S/T	0.82	0.74	0.61	0.47	0.83	0.75	0.61	0.47	1.00	0.77	0.64	0.50	1.00	0.77	0.63	0.49	1.00	0.79	0.65	0.51	1.00	1.00	0.84	0.71	0.56	1.00	0.79	0.65	0.51	1.00	1.00	0.73	0.59			
	ΔT	2.4	22	18	15	2.4	22	18	15	2.4	22	18	15	2.4	22	18	14	2.3	22	18	14	2.5	23	19	15	15	2.3	22	18	14	2.5	23	19	15			
	KW	2.03	2.02	2.02	2.04	2.26	2.26	2.26	2.28	2.28	2.53	2.52	2.52	2.54	2.81	2.81	2.81	2.82	3.13	3.13	3.12	3.14	3.50	3.50	3.50	3.52	3.13	3.13	3.12	3.14	3.50	3.50	3.50	3.52			
	Amps	7.4	7.4	7.4	7.5	8.5	8.5	8.5	8.6	8.6	9.7	9.7	9.8	9.8	11.0	11.0	11.0	11.1	12.5	12.5	12.5	12.5	14.2	14.2	14.2	14.3	12.5	12.5	12.5	12.5	14.2	14.2	14.2	14.3			
1200	MBh	35.5	35.9	37.0	38.6	35.1	35.6	36.7	38.2	34.2	34.7	35.8	37.3	32.7	33.2	34.2	35.8	30.8	31.3	32.3	33.9	29.1	29.5	30.6	32.2	30.8	31.3	32.3	33.9	29.1	29.5	30.6	32.2				
	S/T	0.82	0.74	0.61	0.47	0.83	0.75	0.61	0.47	1.00	0.77	0.64	0.50	1.00	0.79	0.66	0.52	1.00	0.82	0.68	0.54	1.00	1.00	0.73	0.59	1.00	0.82	0.68	0.54	1.00	1.00	0.73	0.59				
	ΔT	2.3	21	18	14	2.3	21	17	14	2.3	21	18	14	2.3	21	17	14	2.3	21	17	14	2.4	22	18	15	15	2.3	21	17	14	2.4	22	18	15			
	KW	2.03	2.03	2.03	2.05	2.27	2.27	2.26	2.28	2.28	2.53	2.53	2.53	2.55	2.82	2.82	2.81	2.83	3.14	3.14	3.13	3.15	3.51	3.51	3.51	3.52	3.14	3.14	3.13	3.15	3.51	3.51	3.51	3.52			
	Amps	7.5	7.5	7.4	7.5	8.6	8.5	8.5	8.6	8.6	9.8	9.8	9.8	9.8	11.1	11.1	11.0	11.1	12.5	12.5	12.5	12.5	14.2	14.2	14.2	14.3	12.5	12.5	12.5	12.5	14.2	14.2	14.2	14.3			
1350	MBh	36.1	36.6	37.7	39.2	35.8	36.3	37.4	38.9	34.9	35.4	36.4	38.0	33.4	33.9	34.9	36.5	31.5	32.0	33.0	34.6	29.7	30.2	31.3	32.8	31.5	32.0	33.0	34.6	29.7	30.2	31.3	32.8				
	S/T	0.84	0.76	0.63	0.48	0.84	0.77	0.63	0.49	1.00	0.79	0.66	0.51	1.00	0.81	0.68	0.53	1.00	0.83	0.70	0.56	1.00	1.00	0.75	0.61	1.00	0.83	0.70	0.56	1.00	1.00	0.75	0.61				
	ΔT	2.2	20	17	13	2.2	20	17	13	2.2	20	17	13	2.2	20	17	13	2.2	20	16	13	2.3	21	17	14	14	2.2	20	16	13	2.3	21	17	14			
	KW	2.04	2.04	2.04	2.06	2.28	2.28	2.27	2.29	2.29	2.54	2.54	2.54	2.56	2.83	2.83	2.82	2.84	3.15	3.15	3.14	3.16	3.52	3.52	3.52	3.53	3.15	3.15	3.14	3.16	3.52	3.52	3.52	3.53			
	Amps	7.5	7.5	7.5	7.6	8.6	8.6	8.6	8.7	8.7	9.8	9.8	9.8	9.9	11.1	11.1	11.1	11.2	12.6	12.6	12.5	12.6	14.3	14.3	14.3	14.3	12.6	12.6	12.5	12.6	14.3	14.3	14.3	14.3			

IDB: Entering Indoor Dry Bulb Temperature
 High and low pressures are measured at the liquid and suction service valves.
 Shaded area reflects ACCA (TVA) conditions
 kW = Total system power
 Amps = outdoor unit amps (comp.+fan)

IDB	AIRFLOW	OUTDOOR AMBIENT TEMPERATURE												ENTERING INDOOR WET BULB TEMPERATURE											
		65				75				85				95				105				115			
		59	63	67	71	59	63	67	71	59	63	67	71	59	63	67	71	59	63	67	71	59	63	67	71
80	MBh	35.2	35.7	36.8	38.3	34.9	35.4	36.5	38.0	34.0	34.5	35.6	37.1	32.5	33.0	34.0	35.6	30.6	31.1	32.1	33.7	28.8	29.3	30.4	31.9
	S/T	0.92	0.84	0.71	0.6	1.00	0.85	0.71	0.57	1.00	0.87	0.74	0.6	1.00	0.89	0.76	0.61	1.00	1.00	0.78	0.6	1.00	1.00	0.83	0.69
	ΔT	28	26	23	19	28	26	22	19	28	26	23	19	28	26	22	19	28	26	22	18	29	27	23	20
	KW	2.03	2.03	2.02	2.0	2.26	2.26	2.26	2.28	2.53	2.53	2.52	2.5	2.81	2.81	2.81	2.83	3.13	3.13	3.13	3.1	3.51	3.50	3.50	3.52
	Amps	7.4	7.4	7.4	7.5	8.5	8.5	8.5	8.6	9.7	9.7	9.7	9.8	11.0	11.0	11.0	11.1	12.5	12.5	12.5	12.6	14.2	14.2	14.2	14.3
	HI PR	256	257	259	263	296	297	298	303	337	339	340	345	382	384	385	390	431	432	434	438	483	484	486	490
LO PR	122	124	127	132	130	131	134	139	136	137	140	146	141	143	146	151	147	148	151	156	153	155	158	163	
1100	MBh	35.6	36.1	37.2	38.7	35.3	35.8	36.8	38.4	34.4	34.9	35.9	37.5	32.9	33.4	34.4	36.0	31.0	31.5	32.5	34.1	29.2	29.7	30.8	32.3
	S/T	1.00	0.87	0.73	0.6	1.00	0.87	0.74	0.60	1.00	0.90	0.76	0.6	1.00	0.92	0.78	0.64	1.00	1.00	0.81	0.7	1.00	1.00	0.86	0.72
	ΔT	27	25	22	18	27	25	22	18	27	26	22	18	27	25	22	18	27	25	21	18	28	26	23	19
	KW	2.04	2.03	2.03	2.1	2.27	2.27	2.27	2.28	2.54	2.53	2.53	2.6	2.82	2.82	2.81	2.83	3.14	3.14	3.13	3.2	3.51	3.51	3.51	3.53
	Amps	7.5	7.5	7.5	7.5	8.6	8.6	8.5	8.6	9.8	9.8	9.7	9.8	11.1	11.1	11.1	11.1	12.5	12.5	12.5	12.6	14.2	14.2	14.2	14.3
	HI PR	257	258	260	265	297	298	300	304	339	340	342	346	384	385	387	391	432	434	435	440	484	485	487	492
LO PR	124	125	128	133	131	132	135	141	137	139	142	147	143	144	147	152	148	150	153	158	155	156	159	164	
1350	MBh	36.3	36.8	37.8	39.4	36.0	36.5	37.5	39.1	35.1	35.6	36.6	38.2	33.6	34.0	35.1	36.7	31.7	32.1	33.2	34.8	29.9	30.4	31.4	33.0
	S/T	1.00	0.89	0.75	0.6	1.00	0.89	0.76	0.61	1.00	0.92	0.78	0.6	1.00	1.00	0.80	0.66	1.00	1.00	0.82	0.7	1.00	1.00	0.88	0.73
	ΔT	26	24	21	17	26	24	21	17	27	25	21	17	26	24	21	17	26	24	20	17	27	25	22	18
	KW	2.05	2.04	2.04	2.1	2.28	2.28	2.28	2.29	2.55	2.54	2.54	2.6	2.83	2.83	2.83	2.84	3.15	3.15	3.14	3.2	3.52	3.52	3.52	3.54
	Amps	7.5	7.5	7.5	7.6	8.6	8.6	8.6	8.7	9.8	9.8	9.8	9.9	11.1	11.1	11.1	11.2	12.6	12.6	12.6	12.6	14.3	14.3	14.3	14.3
	HI PR	260	261	262	267	299	301	302	307	341	342	344	349	386	387	389	394	435	436	438	442	487	488	489	494
LO PR	126	127	131	136	133	135	138	143	140	141	144	149	145	147	150	155	150	152	155	160	157	159	162	167	

IDB	AIRFLOW	OUTDOOR AMBIENT TEMPERATURE												ENTERING INDOOR WET BULB TEMPERATURE											
		65				75				85				95				105				115			
		59	63	67	71	59	63	67	71	59	63	67	71	59	63	67	71	59	63	67	71	59	63	67	71
85	MBh	35.8	36.3	37.3	38.9	35.5	36.0	37.0	38.6	34.6	35.1	36.1	37.7	33.1	33.5	34.6	36.2	31.2	31.7	32.7	34.3	29.4	29.9	30.9	32.5
	S/T	1.00	0.94	0.81	0.67	1.00	0.95	0.81	0.67	1.00	1.00	0.84	0.70	1.00	1.00	0.86	0.72	1.00	1.00	0.88	0.74	1.00	1.00	1.00	0.82
	ΔT	32	30	26	23	32	30	26	23	32	30	26	23	32	30	26	22	31	30	26	22	33	31	27	23
	KW	2.03	2.03	2.03	2.04	2.27	2.27	2.26	2.28	2.53	2.53	2.53	2.54	2.82	2.82	2.81	2.83	3.14	3.13	3.13	3.15	3.51	3.51	3.50	3.52
	Amps	7.5	7.5	7.4	7.5	8.5	8.5	8.5	8.6	9.8	9.7	9.7	9.8	11.1	11.1	11.0	11.1	12.5	12.5	12.5	12.6	14.2	14.2	14.2	14.3
	HI PR	257	258	260	264	297	298	300	304	339	340	341	346	384	385	386	391	432	433	435	439	484	485	487	491
LO PR	124	126	129	134	131	133	136	141	138	139	142	147	143	145	148	153	148	150	153	158	155	157	160	165	
1100	MBh	36.2	36.7	37.7	39.3	35.9	36.4	37.4	39.0	35.0	35.5	36.5	38.1	33.4	33.9	35.0	36.5	31.5	32.0	33.1	34.6	29.8	30.3	31.3	32.9
	S/T	1.00	0.97	0.83	0.69	1.00	0.98	0.84	0.70	1.00	1.00	0.87	0.72	1.00	1.00	0.89	0.74	1.00	1.00	0.91	0.76	1.00	1.00	1.00	0.82
	ΔT	31	29	26	22	31	29	25	22	31	29	26	22	31	29	25	22	31	29	25	22	32	30	26	23
	KW	2.04	2.04	2.03	2.05	2.28	2.27	2.27	2.29	2.54	2.54	2.53	2.55	2.83	2.82	2.82	2.84	3.14	3.14	3.14	3.16	3.52	3.52	3.51	3.53
	Amps	7.5	7.5	7.5	7.6	8.6	8.6	8.6	8.6	9.8	9.8	9.8	9.8	11.1	11.1	11.1	11.2	12.6	12.5	12.5	12.6	14.3	14.3	14.2	14.3
	HI PR	258	260	261	266	298	299	301	306	340	341	343	347	385	386	388	392	434	435	437	441	485	487	488	493
LO PR	125	127	130	135	133	134	137	142	139	141	144	149	145	146	149	154	150	151	154	159	156	158	161	166	
1200	MBh	36.9	37.4	38.4	40.0	36.6	37.1	38.1	39.7	35.7	36.2	37.2	38.8	34.1	34.6	35.7	37.2	32.2	32.7	33.8	35.3	30.5	31.0	32.0	33.6
	S/T	1.00	0.99	0.85	0.71	1.00	1.00	0.86	0.72	1.00	1.00	0.88	0.74	1.00	1.00	0.90	0.76	1.00	1.00	0.92	0.78	1.00	1.00	1.00	0.83
	ΔT	30	28	25	21	30	28	25	21	30	28	25	21	30	28	25	21	30	28	24	21	31	29	25	22
	KW	2.05	2.05	2.04	2.06	2.29	2.28	2.28	2.30	2.55	2.55	2.54	2.56	2.84	2.83	2.83	2.85	3.15	3.15	3.15	3.17	3.53	3.53	3.52	3.54
	Amps	7.5	7.5	7.5	7.6	8.6	8.6	8.6	8.7	9.8	9.8	9.8	9.9	11.1	11.1	11.1	11.2	12.6	12.6	12.6	12.7	14.3	14.3	14.3	14.4
	HI PR	261	262	264	268	301	302	304	308	342	344	345	350	387	389	390	395	436	437	439	443	488	489	491	495
LO PR	128	129	132	137	135	137	140	145	141	143	146	151	147	148	151	157	152	154	157	162	159	160	163	168	

IDB: Entering Indoor Dry Bulb Temperature
 High and low pressures are measured at the liquid and suction service valves.
 Shaded area reflects AHRI conditions
 kW = Total system power
 Amps = outdoor unit amps (comp.+fan)

IDB		OUTDOOR AMBIENT TEMPERATURE															105															115														
		65					75					85					95					105					115																			
		ENTERING INDOOR WET BULB TEMPERATURE																																												
AIRFLOW	59	63	67	71	59	63	67	71	59	63	67	71	59	63	67	71	59	63	67	71	59	63	67	71	59	63	67	71																		
1225	MBh	39.7	40.2	41.4	-	39.3	39.9	41.1	-	38.3	38.8	40.0	-	36.5	37.1	38.2	-	34.3	34.9	36.1	-	32.3	32.9	34.1	-	34.3	34.9	36.1	-	32.3	32.9	34.1	-	34.3	34.9	36.1	-	32.3	32.9	34.1	-					
	S/T	0.63	0.55	0.41	-	0.64	0.56	0.42	-	0.66	0.58	0.44	-	1.00	0.60	0.46	-	1.00	0.63	0.49	-	1.00	0.68	0.54	-	1.00	0.63	0.49	-	1.00	0.68	0.54	-	1.00	0.63	0.49	-	1.00	0.68	0.54	-					
	ΔT	20	18	15	-	20	18	15	-	20	18	15	-	20	18	15	-	20	18	14	-	21	19	15	-	20	18	14	-	21	19	15	-	20	18	14	-	21	19	15	-					
	KW	2.32	2.32	2.31	-	2.59	2.59	2.58	-	2.89	2.89	2.88	-	3.21	3.21	3.21	-	3.58	3.57	3.57	-	4.00	4.00	4.00	-	3.58	3.57	3.57	-	4.00	4.00	4.00	-	3.58	3.57	3.57	-	4.00	4.00	4.00	-					
	Amps	8.3	8.3	8.3	-	9.5	9.5	9.5	-	10.9	10.9	10.9	-	12.4	12.4	12.3	-	14.0	14.0	14.0	-	16.0	16.0	16.0	-	14.0	14.0	14.0	-	16.0	16.0	16.0	-	14.0	14.0	14.0	-	16.0	16.0	16.0	-					
1400	MBh	40.2	40.8	41.9	-	39.8	40.4	41.6	-	38.8	39.4	40.6	-	37.0	37.6	38.8	-	34.8	35.4	36.6	-	32.9	33.4	34.6	-	34.8	35.4	36.6	-	32.9	33.4	34.6	-	34.8	35.4	36.6	-	32.9	33.4	34.6	-					
	S/T	0.69	0.61	0.47	-	0.70	0.62	0.48	-	0.73	0.65	0.51	-	1.00	0.67	0.53	-	1.00	0.69	0.55	-	1.00	0.74	0.60	-	1.00	0.69	0.55	-	1.00	0.74	0.60	-	1.00	0.69	0.55	-	1.00	0.74	0.60	-					
	ΔT	19	17	13	-	19	17	13	-	19	17	14	-	19	17	13	-	18	17	13	-	20	18	14	-	19	17	13	-	20	18	14	-	19	17	13	-	20	18	14	-					
	KW	2.34	2.33	2.33	-	2.60	2.60	2.60	-	2.90	2.90	2.90	-	3.23	3.23	3.22	-	3.59	3.59	3.58	-	4.02	4.01	4.01	-	3.59	3.59	3.58	-	4.02	4.01	4.01	-	3.59	3.59	3.58	-	4.02	4.01	4.01	-					
	Amps	8.4	8.3	8.3	-	9.6	9.6	9.6	-	11.0	10.9	10.9	-	12.4	12.4	12.4	-	14.1	14.1	14.1	-	16.0	16.0	16.0	-	14.1	14.1	14.1	-	16.0	16.0	16.0	-	14.1	14.1	14.1	-	16.0	16.0	16.0	-					
1575	MBh	40.8	41.4	42.6	-	40.5	41.0	42.2	-	39.4	40.0	41.2	-	37.7	38.2	39.4	-	35.5	36.0	37.2	-	33.5	34.0	35.2	-	35.5	36.0	37.2	-	33.5	34.0	35.2	-	35.5	36.0	37.2	-	33.5	34.0	35.2	-					
	S/T	0.73	0.65	0.51	-	0.74	0.66	0.52	-	1.00	0.68	0.54	-	1.00	0.70	0.56	-	1.00	0.73	0.58	-	1.00	1.00	0.64	-	1.00	0.73	0.58	-	1.00	1.00	0.64	-	1.00	0.73	0.58	-	1.00	1.00	0.64	-					
	ΔT	18	16	13	-	18	16	12	-	18	16	13	-	18	16	12	-	17	16	12	-	19	17	13	-	18	16	12	-	19	17	13	-	18	16	12	-	19	17	13	-					
	KW	2.35	2.34	2.34	-	2.62	2.61	2.61	-	2.92	2.91	2.91	-	3.24	3.24	3.23	-	3.60	3.60	3.60	-	4.03	4.03	4.02	-	3.60	3.60	3.60	-	4.03	4.03	4.02	-	3.60	3.60	3.60	-	4.03	4.03	4.02	-					
	Amps	8.4	8.4	8.4	-	9.6	9.6	9.6	-	11.0	11.0	11.0	-	12.5	12.5	12.5	-	14.2	14.1	14.1	-	16.1	16.1	16.1	-	14.2	14.1	14.1	-	16.1	16.1	16.1	-	14.2	14.1	14.1	-	16.1	16.1	16.1	-					

IDB		OUTDOOR AMBIENT TEMPERATURE															105															115														
		65					75					85					95					105					115																			
		ENTERING INDOOR WET BULB TEMPERATURE																																												
AIRFLOW	59	63	67	71	59	63	67	71	59	63	67	71	59	63	67	71	59	63	67	71	59	63	67	71	59	63	67	71																		
1225	MBh	39.7	40.3	41.4	43.3	39.3	39.9	41.1	42.9	38.3	38.9	40.1	41.9	36.5	37.1	38.3	40.1	34.3	34.9	36.1	37.9	32.4	32.9	34.1	35.9	34.3	34.9	36.1	37.9	32.4	32.9	34.1	35.9	34.3	34.9	36.1	37.9	32.4	32.9	34.1	35.9					
	S/T	0.77	0.69	0.55	0.40	1.00	0.69	0.55	0.40	1.00	0.72	0.58	0.43	1.00	0.74	0.60	0.45	1.00	0.76	0.62	0.47	1.00	1.00	0.67	0.53	1.00	0.76	0.62	0.47	1.00	1.00	0.67	0.53	1.00	0.76	0.62	0.47	1.00	1.00	0.67	0.53					
	ΔT	24	22	19	15	24	22	19	15	24	22	19	15	24	22	19	15	24	22	18	15	25	25	23	19	16	24	22	18	15	25	25	23	19	16	24	22	18	15	25	25	23	19	16		
	KW	2.32	2.32	2.31	2.33	2.59	2.59	2.58	2.60	2.60	2.89	2.89	2.88	2.90	3.21	3.21	3.21	3.23	3.58	3.57	3.57	3.59	4.00	4.00	3.99	4.01	3.58	3.57	3.57	3.59	4.00	4.00	3.99	4.01	3.58	3.57	3.57	3.59	4.00	4.00	3.99	4.01				
	Amps	8.3	8.3	8.3	8.0	9.5	9.5	9.5	9.6	9.6	10.9	10.9	10.9	11.0	12.4	12.4	12.3	12.4	14.0	14.0	14.0	14.0	16.0	16.0	15.9	16.0	14.0	14.0	14.0	14.0	16.0	16.0	15.9	16.0	14.0	14.0	14.0	14.0	16.0	16.0	15.9	16.0				
1400	MBh	40.2	40.8	42.0	43.8	39.9	40.4	41.6	43.4	38.8	39.4	40.6	42.4	37.0	37.6	38.8	40.6	34.9	35.4	36.6	38.4	32.9	33.4	34.6	36.4	34.9	35.4	36.6	38.4	32.9	33.4	34.6	36.4	34.9	35.4	36.6	38.4	32.9	33.4	34.6	36.4					
	S/T	0.83	0.75	0.61	0.46	1.00	0.76	0.61	0.47	1.00	0.78	0.64	0.49	1.00	0.80	0.66	0.51	1.00	1.00	0.68	0.53	1.00	1.00	0.74	0.59	1.00	1.00	0.68	0.53	1.00	1.00	0.74	0.59	1.00	1.00	0.68	0.53	1.00	1.00	0.74	0.59					
	ΔT	23	21	17	14	23	21	17	14	23	21	18	14	23	21	17	14	22	21	17	14	24	24	22	18	15	22	21	17	14	24	24	22	18	15	22	21	17	14	24	24	22	18	15		
	KW	2.33	2.33	2.33	2.35	2.60	2.60	2.60	2.62	2.62	2.90	2.90	2.92	2.92	3.23	3.22	3.22	3.24	3.59	3.59	3.58	3.60	4.01	4.01	4.01	4.03	3.59	3.59	3.58	3.60	4.01	4.01	4.01	4.03	3.59	3.59	3.58	3.60	4.01	4.01	4.01	4.03				
	Amps	8.3	8.3	8.3	8.0	9.6	9.6	9.6	9.6	9.6	10.9	10.9	10.9	11.0	12.4	12.4	12.4	12.4	14.1	14.1	14.1	14.0	16.0	16.0	16.0	16.1	14.1	14.1	14.1	14.0	16.0	16.0	16.0	16.1	14.1	14.1	14.1	14.0	16.0	16.0	16.0	16.1				
1575	MBh	40.8	41.4	42.6	44.4	40.5	41.1	42.2	44.0	39.5	40.0	41.2	43.0	37.7	38.2	39.4	41.2	35.5	36.1	37.2	39.1	33.5	34.1	35.3	37.1	35.5	36.1	37.2	39.1	33.5	34.1	35.3	37.1	35.5	36.1	37.2	39.1	33.5	34.1	35.3	37.1					
	S/T	0.86	0.78	0.64	0.49	1.00	0.79	0.65	0.50	1.00	0.82	0.68	0.53	1.00	0.84	0.70	0.55	1.00	1.00	0.72	0.57	1.00	1.00	0.77	0.62	1.00	1.00	0.72	0.57	1.00	1.00	0.77	0.62	1.00	1.00	0.72	0.57	1.00	1.00	0.77	0.62					
	ΔT	22	20	17	13	22	20	17	13	22	20	17	13	22	20	16	13	21	20	16	13	23	23	21	17	14	21	20	16	13	23	23	21	17	14	21	20	16	13	23	23	21	17	14		
	KW	2.35	2.34	2.34	2.36	2.61	2.61	2.61	2.63	2.63	2.91	2.91	2.93	2.93	3.24	3.24	3.23	3.25	3.60	3.60	3.59	3.61	4.03	4.02	4.02	4.04	3.60	3.60	3.59	3.61	4.03	4.02	4.02	4.04	3.60	3.60	3.59	3.61	4.03	4.02	4.02	4.04				
	Amps	8.4	8.4	8.4	8.0	9.6	9.6	9.6	9.6	10.0	11.0	11.0	11.0	11.0	12.5	12.5	12.5	13.0	14.1	14.1	14.1	14.0	16.1	16.1	16.1	16.2	14.1	14.1	14.1	14.0	16.1	16.1	16.1	16.2	14.1	14.1	14.1	14.0	16.1	16.1	16.1	16.2				

IDB: Entering Indoor Dry Bulb Temperature
 High and low pressures are measured at the liquid and suction service valves.
 Shaded area reflects ACCA (TVA) conditions
 kW = Total system power
 Amps = outdoor unit amps (comp.+fan)

IDB	AIRFLOW	OUTDOOR AMBIENT TEMPERATURE												ENTERING INDOOR WET BULB TEMPERATURE											
		65				75				85				95				105				115			
		59	63	67	71	59	63	67	71	59	63	67	71	59	63	67	71	59	63	67	71	59	63	67	71
80	MBh	39.9	40.5	41.7	43.5	39.6	40.1	41.3	43.1	38.5	39.1	40.3	42.1	36.7	37.3	38.5	40.3	34.6	35.1	36.3	38.1	32.6	33.1	34.3	36.1
	S/T	1.00	0.82	0.68	0.5	1.00	0.82	0.68	0.53	1.00	0.85	0.71	0.6	1.00	1.00	0.73	0.58	1.00	1.00	0.75	0.6	1.00	1.00	0.81	0.66
	ΔT	28	26	23	19	28	26	23	19	28	26	23	19	28	26	23	19	28	26	23	19	29	27	23	20
	KW	2.32	2.32	2.31	2.3	2.59	2.59	2.58	2.60	2.89	2.89	2.88	2.9	3.21	3.21	3.21	3.23	3.58	3.57	3.57	3.6	4.00	4.00	4.00	4.02
	Amps	8.3	8.3	8.3	8.0	9.5	9.5	9.5	10.0	10.9	10.9	10.9	11.0	12.4	12.4	12.3	12.0	14.0	14.0	14.0	14.0	16.0	16.0	16.0	16.0
1225	HI PR	265	266	268	273	307	308	310	314	351	352	354	358	398	399	401	405	448	449	451	456	502	504	505	510
	LO PR	127	128	131	137	134	136	139	144	141	143	146	151	147	148	152	157	152	154	157	162	159	161	164	169
	MBh	40.4	41.0	42.2	44.0	40.1	40.6	41.8	43.6	39.0	39.6	40.8	42.6	37.3	37.8	39.0	40.8	35.1	35.6	36.8	38.6	33.1	33.6	34.8	36.6
	S/T	1.00	0.88	0.74	0.6	1.00	0.89	0.74	0.60	1.00	0.91	0.77	0.6	1.00	1.00	0.79	0.64	1.00	1.00	0.81	0.7	1.00	1.00	0.87	0.72
	ΔT	27	25	22	18	27	25	21	18	27	25	22	18	27	25	21	18	26	25	21	18	28	26	22	19
1400	KW	2.33	2.33	2.33	2.4	2.60	2.60	2.60	2.62	2.90	2.90	2.90	2.9	3.23	3.23	3.22	3.24	3.59	3.59	3.58	3.6	4.02	4.01	4.01	4.03
	Amps	8.4	8.3	8.3	8.0	9.6	9.6	9.6	10.0	11.0	11.0	11.0	11.0	12.4	12.4	12.4	12.0	14.1	14.1	14.1	14.0	16.0	16.0	16.0	16.1
	HI PR	267	268	270	275	309	310	312	317	353	354	356	360	400	401	403	407	451	452	454	458	505	506	508	512
	LO PR	129	130	133	139	136	138	141	146	143	144	148	153	149	150	153	159	154	156	159	164	161	163	166	171
	MBh	41.1	41.6	42.8	44.6	40.7	41.3	42.4	44.3	39.7	40.2	41.4	43.2	37.9	38.4	39.6	41.4	35.7	36.3	37.4	39.3	33.7	34.3	35.5	37.3
1575	S/T	1.00	0.91	0.77	0.6	1.00	0.92	0.78	0.63	1.00	1.00	0.81	0.7	1.00	1.00	0.83	0.68	1.00	1.00	0.85	0.7	1.00	1.00	1.00	0.75
	ΔT	26	24	21	17	26	24	21	17	26	24	21	17	26	24	21	17	26	24	20	17	27	25	21	18
	KW	2.35	2.34	2.34	2.4	2.62	2.61	2.61	2.63	2.92	2.91	2.91	2.9	3.24	3.24	3.23	3.25	3.60	3.60	3.60	3.6	4.03	4.03	4.02	4.00
	Amps	8.4	8.4	8.4	8.0	9.6	9.6	9.6	10.0	11.0	11.0	11.0	11.0	12.5	12.5	12.5	13.0	14.2	14.1	14.1	14.0	16.1	16.1	16.1	16.2
	HI PR	270	271	273	277	311	312	314	319	355	356	358	363	402	403	405	410	453	454	456	460	507	508	510	514
LO PR	131	132	135	141	138	140	143	148	145	147	150	155	151	152	155	161	156	158	161	166	163	165	168	173	

IDB	AIRFLOW	OUTDOOR AMBIENT TEMPERATURE												ENTERING INDOOR WET BULB TEMPERATURE											
		65				75				85				95				105				115			
		59	63	67	71	59	63	67	71	59	63	67	71	59	63	67	71	59	63	67	71	59	63	67	71
85	MBh	40.6	41.1	42.3	44.1	40.2	40.8	42.0	43.8	39.2	39.7	40.9	42.7	37.4	38.0	39.1	41.0	35.2	35.8	37.0	38.8	33.2	33.8	35.0	36.8
	S/T	1.00	0.92	0.78	0.63	1.00	1.00	0.79	0.64	1.00	1.00	0.81	0.67	1.00	1.00	0.83	0.69	1.00	1.00	0.77	0.71	1.00	1.00	1.00	0.82
	ΔT	31	30	26	23	31	30	26	23	32	30	26	23	31	30	26	23	31	29	26	22	32	30	27	24
	KW	2.33	2.32	2.32	2.34	2.59	2.59	2.59	2.61	2.89	2.89	2.89	2.91	3.22	3.22	3.21	3.23	3.58	3.58	3.58	3.60	4.01	4.01	4.00	4.02
	Amps	8.3	8.3	8.3	8.0	9.5	9.5	9.5	10.0	10.9	10.9	10.9	11.0	12.4	12.4	12.4	12.0	14.1	14.0	14.0	14.0	16.0	16.0	16.0	16.1
1225	HI PR	266	267	269	274	308	309	311	316	352	353	355	359	399	400	402	406	450	451	453	457	504	505	507	511
	LO PR	129	130	133	139	136	138	141	146	143	145	148	153	149	150	153	159	154	156	159	164	161	163	166	171
	MBh	41.1	41.7	42.8	44.7	40.7	41.3	42.5	44.3	39.7	40.3	41.5	43.3	37.9	38.5	39.7	41.5	35.7	36.3	37.5	39.3	33.8	34.3	35.5	37.3
	S/T	1.00	0.99	0.84	0.69	1.00	1.00	0.85	0.70	1.00	1.00	0.88	0.73	1.00	1.00	0.90	0.75	1.00	1.00	0.77	0.71	1.00	1.00	1.00	0.82
	ΔT	30	29	25	22	30	28	25	22	31	29	25	22	30	28	25	22	30	28	25	21	31	29	26	22
1400	KW	2.34	2.34	2.33	2.35	2.61	2.61	2.60	2.62	2.91	2.91	2.90	2.92	3.23	3.23	3.23	3.25	3.60	3.59	3.59	3.61	4.02	4.02	4.01	4.04
	Amps	8.4	8.4	8.3	8.0	9.6	9.6	9.6	10.0	11.0	11.0	11.0	11.0	12.5	12.5	12.4	13.0	14.1	14.1	14.1	14.0	16.1	16.1	16.0	16.1
	HI PR	269	270	272	276	310	311	313	318	354	355	357	362	401	402	404	409	452	453	455	459	506	507	509	514
	LO PR	130	132	135	141	138	140	143	148	145	146	150	155	150	152	155	161	156	158	161	166	163	165	168	173
	MBh	41.7	42.3	43.5	45.3	41.4	41.9	43.1	44.9	40.3	40.9	42.1	43.9	38.5	39.1	40.3	42.1	36.4	36.9	38.1	39.9	34.4	34.9	36.1	37.9
1575	S/T	1.00	1.00	0.88	0.73	1.00	1.00	0.89	0.74	1.00	1.00	0.91	0.76	1.00	1.00	0.93	0.78	1.00	1.00	0.81	0.81	1.00	1.00	1.00	0.86
	ΔT	29	28	24	21	29	28	24	21	30	28	24	21	29	28	24	21	29	27	24	20	30	28	25	21
	KW	2.35	2.35	2.34	2.37	2.62	2.62	2.61	2.63	2.92	2.92	2.91	2.93	3.24	3.24	3.24	3.26	3.61	3.61	3.60	3.62	4.03	4.03	4.03	4.05
	Amps	8.4	8.4	8.4	8.0	9.7	9.6	9.6	10.0	11.0	11.0	11.0	11.0	12.5	12.5	12.5	13.0	14.2	14.2	14.1	14.0	16.1	16.1	16.1	16.2
	HI PR	271	272	274	278	312	314	315	320	356	357	359	364	403	404	406	411	454	455	457	462	508	509	511	516
LO PR	132	134	137	143	140	142	145	150	147	148	152	157	153	154	157	163	158	160	163	168	165	167	170	175	

IDB: Entering Indoor Dry Bulb Temperature
 High and low pressures are measured at the liquid and suction service valves.
 Shaded area reflects AHRI conditions
 KW = Total system power
 Amps = outdoor unit amps (comp.+fan)

IDB		OUTDOOR AMBIENT TEMPERATURE												105												115																							
		65						75						85						95						105						115																	
		AIRFLOW		59	63	67	71	59	63	67	71	59	63	67	71	59	63	67	71	59	63	67	71	59	63	67	71	59	63	67	71	59	63	67	71														
		39.7	40.3	41.4	43.3	39.3	39.9	41.1	42.9	38.3	38.9	40.1	41.9	36.5	37.1	38.2	-	34.3	34.9	36.1	-	32.3	32.9	34.1	-	39.7	40.3	41.4	43.3	39.3	39.9	41.1	42.9	38.3	38.9	40.1	41.9	36.5	37.1	38.2	-	34.3	34.9	36.1	-	32.3	32.9	34.1	-
		0.77	0.69	0.55	0.40	1.00	0.69	0.55	0.40	1.00	0.72	0.58	0.43	1.00	0.74	0.60	0.46	1.00	0.76	0.62	0.47	1.00	0.68	0.54	-	0.77	0.69	0.55	0.40	1.00	0.69	0.55	0.40	1.00	0.72	0.58	0.43	1.00	0.74	0.60	0.46	1.00	0.76	0.62	0.47	1.00	0.68	0.54	-
		24	22	19	15	24	22	19	15	24	22	19	15	24	22	19	15	24	22	19	15	24	22	19	15	24	22	19	15	24	22	19	15	24	22	19	15	24	22	19	15	24	22	19	15	24	22	19	15
		2.32	2.32	2.31	2.33	2.59	2.59	2.58	2.60	2.89	2.89	2.88	2.90	3.21	3.21	3.21	3.23	3.58	3.57	3.57	3.59	4.00	4.00	3.99	4.01	2.32	2.32	2.31	2.33	2.59	2.59	2.58	2.60	2.89	2.89	2.88	2.90	3.21	3.21	3.21	3.23	3.58	3.57	3.57	3.59	4.00	4.00	3.99	4.01
		8.3	8.3	8.3	8.0	9.5	9.5	9.5	9.6	10.9	10.9	10.9	11.0	12.4	12.4	12.3	12.4	14.0	14.0	14.0	14.0	16.0	16.0	15.9	16.0	8.3	8.3	8.3	8.0	9.5	9.5	9.5	9.6	10.9	10.9	10.9	11.0	12.4	12.4	12.3	12.4	14.0	14.0	14.0	14.0	16.0	16.0	15.9	16.0
		269	270	272	277	311	312	314	314	354	355	357	360	399	398	400	402	448	449	451	453	504	505	507	510	269	270	272	277	311	312	314	314	354	355	357	360	399	398	400	402	448	449	451	453	504	505	507	510
		130	132	135	140	138	139	142	148	144	146	149	155	148	150	153	155	156	157	160	166	163	164	167	173	130	132	135	140	138	139	142	148	144	146	149	155	148	150	153	155	156	157	160	166	163	164	167	173
		40.8	41.4	42.6	44.4	40.5	41.1	42.2	44.0	39.5	40.0	41.2	43.0	37.7	38.2	39.4	41.2	35.5	36.1	37.2	39.1	33.5	34.1	35.3	37.1	40.8	41.4	42.6	44.4	40.5	41.1	42.2	44.0	39.5	40.0	41.2	43.0	37.7	38.2	39.4	41.2	35.5	36.1	37.2	39.1	33.5	34.1	35.3	37.1
		0.86	0.78	0.64	0.49	1.00	0.79	0.65	0.50	1.00	0.82	0.68	0.53	1.00	0.84	0.70	0.55	1.00	0.86	0.72	0.57	1.00	0.77	0.62	0.59	0.86	0.78	0.64	0.49	1.00	0.79	0.65	0.50	1.00	0.82	0.68	0.53	1.00	0.84	0.70	0.55	1.00	0.86	0.72	0.57	1.00	0.77	0.62	0.59
		22	20	17	13	22	20	17	13	22	20	17	13	22	20	16	13	21	20	16	13	21	20	17	14	22	20	17	13	22	20	17	13	22	20	17	13	21	20	16	13	21	20	16	13	21	20	17	14
		2.35	2.34	2.34	2.36	2.61	2.61	2.61	2.63	2.91	2.91	2.91	2.93	3.24	3.24	3.23	3.25	3.60	3.60	3.59	3.61	4.03	4.03	4.02	4.04	2.35	2.34	2.34	2.36	2.61	2.61	2.61	2.63	2.91	2.91	2.91	2.93	3.24	3.24	3.23	3.25	3.60	3.60	3.59	3.61	4.03	4.03	4.02	4.04
		8.4	8.4	8.4	8.0	9.6	9.6	9.6	10.0	11.0	11.0	11.0	11.0	12.5	12.5	12.5	13.0	14.1	14.1	14.1	14.0	16.1	16.1	16.1	16.2	8.4	8.4	8.4	8.0	9.6	9.6	9.6	10.0	11.0	11.0	11.0	11.0	12.5	12.5	12.5	13.0	14.1	14.1	14.1	14.0	16.1	16.1	16.1	16.2
		269	270	272	277	311	312	314	318	354	356	357	362	402	403	405	409	452	453	455	460	506	508	509	514	269	270	272	277	311	312	314	318	354	356	357	362	402	403	405	409	452	453	455	460	506	508	509	514
		130	132	135	140	138	139	142	148	144	146	149	155	150	152	155	160	163	164	166	173	163	164	167	173	130	132	135	140	138	139	142	148	144	146	149	155	150	152	155	160	163	164	166	173	163	164	167	173

IDB: Entering Indoor Dry Bulb Temperature
 High and low pressures are measured at the liquid and suction service valves.
 Shaded area reflects ACCA (TVA) conditions
 kW = Total system power
 Amps = outdoor unit amps (comp.+fan)

IDB		OUTDOOR AMBIENT TEMPERATURE																																				
		65						75						85						95						105						115						
		AIRFLOW			59			63			67			71			59			63			67			71			59			63			67			71
ENTERING INDOOR WET BULB TEMPERATURE																																						
1225	MBh	39.9	40.5	41.7	43.5	39.6	40.1	41.3	43.1	38.5	39.1	40.3	42.1	36.7	37.3	38.5	40.3	34.6	35.1	36.3	38.1	32.6	33.1	34.3	36.1													
	S/T	1.00	0.82	0.68	0.5	1.00	0.82	0.68	0.53	1.00	0.85	0.71	0.6	1.00	1.00	0.73	0.58	1.00	1.00	0.75	0.6	1.00	1.00	0.81	0.66													
	ΔT	28	26	23	19	28	26	23	19	28	26	23	19	28	26	23	19	28	26	23	19	29	27	23	20													
	KW	2.32	2.32	2.31	2.3	2.59	2.59	2.58	2.60	2.89	2.89	2.88	2.9	3.21	3.21	3.21	3.23	3.58	3.57	3.57	3.6	4.00	4.00	4.00	4.02													
	Amps	8.3	8.3	8.3	8.0	9.5	9.5	9.5	10.0	10.9	10.9	10.9	11.0	12.4	12.4	12.3	12.0	14.0	14.0	14.0	14.0	16.0	16.0	16.0	16.0													
	HI PR	265	266	268	273	307	308	310	314	351	352	354	358	398	399	401	405	448	449	451	456	502	504	505	510													
LO PR	127	128	131	137	134	136	139	144	141	143	146	151	147	148	152	157	152	154	157	162	159	161	164	169														
1400	MBh	40.4	41.0	42.2	44.0	40.1	40.6	41.8	43.6	39.0	39.6	40.8	42.6	37.3	37.8	39.0	40.8	35.1	35.6	36.8	38.6	33.1	33.6	34.8	36.6													
	S/T	1.00	0.88	0.74	0.6	1.00	0.89	0.74	0.60	1.00	0.91	0.77	0.6	1.00	1.00	0.79	0.64	1.00	1.00	0.81	0.7	1.00	1.00	0.87	0.72													
	ΔT	27	25	22	18	27	25	21	18	27	25	22	18	27	25	21	18	26	25	21	18	28	26	22	19													
	KW	2.33	2.33	2.33	2.4	2.60	2.60	2.60	2.62	2.90	2.90	2.90	2.9	3.23	3.23	3.22	3.24	3.59	3.59	3.58	3.6	4.02	4.01	4.01	4.03													
	Amps	8.4	8.3	8.3	8.0	9.6	9.6	9.6	10.0	11.0	10.9	10.9	11.0	12.4	12.4	12.4	12.0	14.1	14.1	14.1	14.0	16.0	16.0	16.0	16.1													
	HI PR	267	268	270	275	309	310	312	317	353	354	356	360	400	401	403	407	451	452	454	458	505	506	508	512													
LO PR	129	130	133	139	136	138	141	146	143	144	148	153	149	150	153	159	154	156	159	164	161	163	166	171														
1575	MBh	41.1	41.6	42.8	44.6	40.7	41.3	42.4	44.3	39.7	40.2	41.4	43.2	37.9	38.4	39.6	41.4	35.7	36.3	37.4	39.3	33.7	34.3	35.5	37.3													
	S/T	1.00	0.91	0.77	0.6	1.00	0.92	0.78	0.63	1.00	1.00	0.81	0.7	1.00	1.00	0.83	0.68	1.00	1.00	0.85	0.7	1.00	1.00	1.00	0.75													
	ΔT	26	24	21	17	26	24	21	17	26	24	21	17	26	24	21	17	26	24	20	17	27	25	21	18													
	KW	2.35	2.34	2.34	2.4	2.62	2.61	2.61	2.63	2.92	2.91	2.91	2.9	3.24	3.24	3.23	3.25	3.60	3.60	3.60	3.6	4.03	4.03	4.02	4.00													
	Amps	8.4	8.4	8.4	8.0	9.6	9.6	9.6	10.0	11.0	11.0	11.0	11.0	12.5	12.5	12.5	13.0	14.2	14.1	14.1	14.0	16.1	16.1	16.1	16.2													
	HI PR	270	271	273	277	311	312	314	319	355	356	358	363	402	403	405	410	453	454	456	460	507	508	510	514													
LO PR	131	132	135	141	138	140	143	148	145	147	150	155	151	152	155	161	156	158	161	166	163	165	168	173														

IDB		OUTDOOR AMBIENT TEMPERATURE																																				
		65						75						85						95						105						115						
		AIRFLOW			59			63			67			71			59			63			67			71			59			63			67			71
ENTERING INDOOR WET BULB TEMPERATURE																																						
1225	MBh	40.6	41.1	42.3	44.1	40.2	40.8	42.0	43.8	39.2	39.7	40.9	42.7	37.4	38.0	39.1	41.0	35.2	35.8	37.0	38.8	33.2	33.8	35.0	36.8													
	S/T	1.00	0.92	0.78	0.63	1.00	1.00	0.79	0.64	1.00	1.00	0.81	0.67	1.00	1.00	0.83	0.69	1.00	1.00	1.00	0.71	1.00	1.00	1.00	0.76													
	ΔT	31	30	26	23	31	30	26	23	32	30	26	23	31	30	26	23	31	29	26	22	32	30	27	24													
	KW	2.33	2.32	2.32	2.34	2.59	2.59	2.59	2.61	2.89	2.89	2.89	2.91	3.22	3.22	3.21	3.23	3.58	3.58	3.58	3.60	4.01	4.01	4.00	4.02													
	Amps	8.3	8.3	8.3	8.0	9.5	9.5	9.5	10.0	10.9	10.9	10.9	11.0	12.4	12.4	12.4	12.0	14.1	14.0	14.0	14.0	16.0	16.0	16.0	16.1													
	HI PR	266	267	269	274	308	309	311	316	352	353	355	359	399	400	402	406	450	451	453	457	504	505	507	511													
LO PR	129	130	133	139	136	138	141	146	143	145	148	153	149	150	153	159	154	156	159	164	161	163	166	171														
1400	MBh	41.1	41.7	42.8	44.7	40.7	41.3	42.5	44.3	39.7	40.3	41.5	43.3	37.9	38.5	39.7	41.5	35.7	36.3	37.5	39.3	33.8	34.3	35.5	37.3													
	S/T	1.00	0.99	0.84	0.69	1.00	1.00	0.85	0.70	1.00	1.00	0.88	0.73	1.00	1.00	0.90	0.75	1.00	1.00	1.00	0.77	1.00	1.00	1.00	0.82													
	ΔT	30	29	25	22	30	28	25	22	31	29	25	22	30	28	25	22	30	28	25	21	31	29	26	22													
	KW	2.34	2.34	2.33	2.35	2.61	2.61	2.60	2.62	2.91	2.91	2.90	2.92	3.23	3.23	3.23	3.25	3.60	3.59	3.59	3.61	4.02	4.02	4.01	4.04													
	Amps	8.4	8.4	8.3	8.0	9.6	9.6	9.6	10.0	11.0	11.0	10.9	11.0	12.5	12.5	12.4	13.0	14.1	14.1	14.1	14.0	16.1	16.1	16.0	16.1													
	HI PR	269	270	272	276	310	311	313	318	354	355	357	362	401	402	404	409	452	453	455	459	506	507	509	514													
LO PR	130	132	135	141	138	140	143	148	145	146	150	155	150	152	155	161	156	158	161	166	163	165	168	173														
1575	MBh	41.7	42.3	43.5	45.3	41.4	41.9	43.1	44.9	40.3	40.9	42.1	43.9	38.5	39.1	40.3	42.1	36.4	36.9	38.1	39.9	34.4	34.9	36.1	37.9													
	S/T	1.00	1.00	0.88	0.73	1.00	1.00	0.89	0.74	1.00	1.00	0.91	0.76	1.00	1.00	0.93	0.78	1.00	1.00	1.00	0.81	1.00	1.00	1.00	0.86													
	ΔT	29	28	24	21	29	28	24	21	30	28	24	21	29	28	24	21	29	27	24	20	30	28	25	21													
	KW	2.35	2.35	2.34	2.37	2.62	2.62	2.61	2.63	2.92	2.92	2.91	2.93	3.24	3.24	3.24	3.26	3.61	3.61	3.60	3.62	4.03	4.03	4.03	4.05													
	Amps	8.4	8.4	8.4	8.0	9.7	9.6	9.6	10.0	11.0	11.0	11.0	11.0	12.5	12.5	12.5	13.0	14.2	14.2	14.1	14.0	16.1	16.1	16.1	16.2													
	HI PR	271	272	274	278	312	314	315	320	356	357	359	364	403	404	406	411	454	455	457	462	508	509	511	516													
LO PR	132	134	137	143	140	142	145	150	147	148	152	157	153	154	157	163	158	160	163	168	165	167	170	175														

IDB: Entering Indoor Dry Bulb Temperature
 High and low pressures are measured at the liquid and suction service valves.
 Shaded area reflects AHRI conditions
 kW = Total system power
 Amps = outdoor unit amps (comp.+fan)

IDB	AIRFLOW	OUTDOOR AMBIENT TEMPERATURE												ENTERING INDOOR WET BULB TEMPERATURE											
		65				75				85				95				105				115			
		59	63	67	71	59	63	67	71	59	63	67	71	59	63	67	71	59	63	67	71	59	63	67	71
70	MBh	46.4	47.1	48.5	-	46.0	46.7	48.0	-	44.8	45.4	46.8	-	42.7	43.4	44.8	-	40.2	40.8	42.2	-	37.9	38.5	39.9	-
	S/T	0.61	0.54	0.41	-	0.62	0.55	0.41	-	0.65	0.57	0.44	-	0.66	0.59	0.46	-	1.00	0.61	0.48	-	1.00	0.66	0.53	-
	ΔT	19	17	14	-	19	17	14	-	19	18	14	-	19	17	14	-	19	17	14	-	20	18	15	-
	KW	2.77	2.77	2.76	-	3.09	3.08	3.08	-	3.44	3.44	3.43	-	3.83	3.82	3.82	-	4.26	4.25	4.25	-	4.76	4.76	4.75	-
	Amps	10.1	10.1	10.0	-	11.5	11.5	11.5	-	13.2	13.2	13.1	-	14.9	14.9	14.9	-	16.9	16.9	16.9	-	19.2	19.2	19.2	-
	HI PR	257	259	260	-	298	299	301	-	341	342	343	-	386	387	389	-	436	437	438	-	488	489	491	-
	LO PR	123	125	128	-	131	132	136	-	137	139	142	-	143	145	148	-	148	150	153	-	155	157	160	-
	MBh	46.9	47.6	48.9	-	46.5	47.1	48.5	-	45.3	45.9	47.3	-	43.2	43.9	45.2	-	40.7	41.3	42.7	-	38.3	39.0	40.4	-
	S/T	0.66	0.58	0.45	-	0.66	0.59	0.45	-	0.69	0.61	0.48	-	1.00	0.63	0.50	-	1.00	0.65	0.52	-	1.00	0.71	0.57	-
	ΔT	18	17	13	-	18	17	13	-	19	17	13	-	18	17	13	-	18	16	13	-	19	17	14	-
	KW	2.78	2.78	2.77	-	3.10	3.10	3.09	-	3.45	3.45	3.45	-	3.84	3.84	3.83	-	4.27	4.27	4.26	-	4.77	4.77	4.76	-
	Amps	10.1	10.1	10.1	-	11.6	11.6	11.6	-	13.2	13.2	13.2	-	15.0	15.0	14.9	-	16.9	16.9	16.9	-	19.3	19.2	19.2	-
HI PR	259	260	262	-	300	301	303	-	342	343	345	-	388	389	391	-	437	438	440	-	490	491	493	-	
LO PR	125	126	129	-	132	134	137	-	139	140	144	-	144	146	149	-	150	151	154	-	157	158	161	-	
MBh	47.9	48.5	49.9	-	47.5	48.1	49.5	-	46.2	46.9	48.3	-	44.2	44.8	46.2	-	41.6	42.3	43.7	-	39.3	40.0	41.3	-	
S/T	0.70	0.62	0.49	-	0.70	0.63	0.49	-	0.73	0.65	0.52	-	1.00	0.67	0.54	-	1.00	0.69	0.56	-	1.00	0.74	0.61	-	
ΔT	17	15	12	-	17	15	12	-	17	16	12	-	17	15	12	-	17	15	12	-	18	16	13	-	
KW	2.80	2.80	2.79	-	3.12	3.11	3.11	-	3.47	3.47	3.46	-	3.86	3.85	3.85	-	4.29	4.28	4.28	-	4.79	4.79	4.78	-	
Amps	10.2	10.2	10.2	-	11.7	11.7	11.6	-	13.3	13.3	13.3	-	15.1	15.0	15.0	-	17.0	17.0	17.0	-	19.3	19.3	19.3	-	
HI PR	262	263	265	-	302	304	305	-	345	346	348	-	391	392	394	-	440	441	443	-	493	494	496	-	
LO PR	127	129	132	-	135	136	140	-	141	143	146	-	147	149	152	-	152	154	157	-	159	161	164	-	
75	MBh	46.4	47.1	48.5	50.6	46.0	46.7	48.1	50.2	44.8	45.5	46.9	49.0	42.7	43.4	44.8	46.9	40.2	40.9	42.2	44.4	37.9	38.5	39.9	42.0
	S/T	0.74	0.67	0.53	0.39	0.75	0.67	0.54	0.40	1.00	0.70	0.56	0.42	1.00	0.72	0.58	0.44	1.00	0.74	0.60	0.46	1.00	1.00	0.66	0.51
	ΔT	23	21	18	15	23	21	18	14	23	22	18	15	23	21	18	14	23	21	18	14	24	22	19	15
	KW	2.77	2.76	2.76	2.78	3.08	3.08	3.08	3.10	3.44	3.44	3.43	3.46	3.82	3.82	3.82	3.84	4.25	4.25	4.25	4.27	4.76	4.76	4.75	4.77
	Amps	10.1	10.1	10.0	10.1	11.5	11.5	11.5	11.6	13.2	13.1	13.1	13.2	14.9	14.9	14.9	15.0	16.9	16.9	16.8	17.0	19.2	19.2	19.1	19.3
	HI PR	258	259	261	265	298	299	301	306	341	342	344	348	386	388	389	394	436	437	439	443	488	490	491	496
	LO PR	123	125	128	133	131	132	136	141	137	139	142	147	143	145	148	153	148	150	153	158	155	157	160	165
	MBh	46.9	47.6	49.0	51.1	46.5	47.2	48.5	50.7	45.3	46.0	47.3	49.5	43.2	43.9	45.3	47.4	40.7	41.3	42.7	44.8	38.4	39.0	40.4	42.5
	S/T	0.79	0.71	0.58	0.44	0.79	0.72	0.58	0.44	1.00	0.74	0.61	0.47	1.00	0.76	0.63	0.49	1.00	0.78	0.65	0.51	1.00	1.00	0.70	0.56
	ΔT	22	21	17	14	22	20	17	14	23	21	17	14	22	20	17	14	22	20	17	13	23	21	18	15
	KW	2.78	2.78	2.77	2.80	3.10	3.09	3.09	3.11	3.45	3.45	3.44	3.47	3.84	3.83	3.83	3.85	4.27	4.26	4.26	4.28	4.77	4.77	4.76	4.79
	Amps	10.1	10.1	10.1	10.2	11.6	11.6	11.5	11.7	13.2	13.2	13.2	13.3	15.0	14.9	14.9	15.0	16.9	16.9	16.9	17.0	19.2	19.2	19.2	19.3
HI PR	259	260	262	267	300	301	303	307	342	344	345	350	388	389	391	396	437	439	440	445	490	491	493	498	
LO PR	125	126	129	135	132	134	137	142	139	140	144	149	144	146	149	154	150	151	155	160	157	158	161	167	
MBh	47.9	48.5	49.9	52.0	47.5	48.1	49.5	51.6	46.3	46.9	48.3	50.4	44.2	44.8	46.2	48.3	41.7	42.3	43.7	45.8	39.3	40.0	41.4	43.5	
S/T	0.82	0.75	0.62	0.47	1.00	0.76	0.62	0.48	1.00	0.78	0.65	0.50	1.00	0.80	0.67	0.52	1.00	0.82	0.69	0.55	1.00	1.00	0.74	0.60	
ΔT	21	19	16	13	21	19	16	12	21	20	16	13	21	19	16	12	21	19	16	12	22	20	17	13	
KW	2.80	2.79	2.79	2.81	3.11	3.11	3.11	3.13	3.47	3.47	3.46	3.49	3.85	3.85	3.85	3.87	4.28	4.28	4.28	4.30	4.79	4.79	4.78	4.80	
Amps	10.2	10.2	10.2	10.3	11.7	11.7	11.6	11.7	13.3	13.3	13.3	13.4	15.1	15.0	15.0	15.1	17.0	17.0	17.0	17.1	19.3	19.3	19.3	19.4	
HI PR	262	263	265	270	303	304	306	310	345	346	348	353	391	392	394	398	440	441	443	448	493	494	496	500	
LO PR	127	129	132	137	135	136	140	145	142	143	146	151	147	149	152	157	152	154	157	162	159	161	164	169	

IDB: Entering Indoor Dry Bulb Temperature
 High and low pressures are measured at the liquid and suction service valves.
 Shaded area reflects ACCA (TVA) conditions
 kW = Total system power
 Amps = outdoor unit amps (comp.+fan)

IDB	AIRFLOW	OUTDOOR AMBIENT TEMPERATURE												ENTERING INDOOR WET BULB TEMPERATURE											
		65				75				85				95				105				115			
		59	63	67	71	59	63	67	71	59	63	67	71	59	63	67	71	59	63	67	71	59	63	67	71
80	MBh	46.7	47.3	48.7	50.8	46.3	46.9	48.3	50.4	45.1	45.7	47.1	49.2	43.0	43.6	45.0	47.1	40.4	41.1	42.5	44.6	38.1	38.8	40.2	42.3
	S/T	1.00	0.79	0.66	0.5	1.00	0.80	0.66	0.52	1.00	0.82	0.69	0.6	1.00	0.84	0.71	0.57	1.00	1.00	0.73	0.6	1.00	1.00	0.78	0.64
	ΔT	27	25	22	19	27	25	22	18	27	26	22	19	27	25	22	18	27	25	22	18	28	26	23	19
	KW	2.77	2.77	2.76	2.8	3.09	3.08	3.08	3.10	3.44	3.44	3.43	3.5	3.83	3.82	3.82	3.84	4.26	4.25	4.25	4.3	4.76	4.76	4.75	4.78
	Amps	10.1	10.1	10.0	10.2	11.5	11.5	11.5	11.6	13.2	13.1	13.1	13.2	14.9	14.9	14.9	15.0	16.9	16.9	16.9	17.0	19.2	19.2	19.2	19.3
	HI PR	258	259	261	266	299	300	302	306	341	342	344	349	387	388	390	394	436	437	439	444	489	490	492	496
	LO PR	124	125	129	134	131	133	136	141	138	140	143	148	144	145	148	153	149	151	154	159	156	157	160	166
	MBh	47.2	47.8	49.2	51.3	46.8	47.4	48.8	50.9	45.5	46.2	47.6	49.7	43.5	44.1	45.5	47.6	40.9	41.6	43.0	45.1	38.6	39.3	40.6	42.8
	S/T	1.00	0.83	0.70	0.6	1.00	0.84	0.71	0.57	1.00	0.86	0.73	0.6	1.00	1.00	0.75	0.61	1.00	1.00	0.77	0.6	1.00	1.00	0.82	0.68
	ΔT	26	25	21	18	26	24	21	18	27	25	21	18	26	24	21	18	26	24	21	17	27	25	22	18
KW	2.78	2.78	2.77	2.8	3.10	3.10	3.09	3.12	3.45	3.45	3.45	3.5	3.84	3.84	3.83	3.86	4.27	4.27	4.26	4.3	4.77	4.77	4.76	4.79	
Amps	10.1	10.1	10.1	10.2	11.6	11.6	11.6	11.7	13.2	13.2	13.2	13.3	15.0	15.0	14.9	15.1	16.9	16.9	16.9	17.0	19.3	19.2	19.2	19.3	
HI PR	260	261	263	267	300	302	303	308	343	344	346	350	389	390	392	396	438	439	441	445	491	492	493	498	
LO PR	125	127	130	135	133	134	138	143	139	141	144	149	145	146	150	155	150	152	155	160	157	159	162	167	
MBh	48.1	48.8	50.2	52.3	47.7	48.4	49.8	51.9	46.5	47.2	48.5	50.7	44.4	45.1	46.5	48.6	41.9	42.5	43.9	46.0	39.6	40.2	41.6	43.7	
S/T	1.00	0.87	0.74	0.6	1.00	0.88	0.75	0.60	1.00	0.90	0.77	0.6	1.00	1.00	0.79	0.65	1.00	1.00	0.81	0.7	1.00	1.00	0.86	0.72	
ΔT	25	23	20	17	25	23	20	16	25	24	20	17	25	23	20	16	25	23	20	16	26	24	21	17	
KW	2.80	2.80	2.79	2.8	3.12	3.11	3.11	3.13	3.47	3.47	3.46	3.5	3.86	3.85	3.85	3.87	4.29	4.28	4.28	4.3	4.79	4.79	4.78	4.81	
Amps	10.2	10.2	10.2	10.3	11.7	11.7	11.6	11.7	13.3	13.3	13.3	13.4	15.1	15.0	15.0	15.1	17.0	17.0	17.0	17.1	19.3	19.3	19.3	19.4	
HI PR	263	264	266	270	303	304	306	311	346	347	349	353	391	392	394	399	441	442	444	448	493	494	496	501	
LO PR	128	130	133	138	136	137	140	145	142	144	147	152	148	149	152	157	153	155	158	163	160	161	165	170	

IDB	AIRFLOW	OUTDOOR AMBIENT TEMPERATURE												ENTERING INDOOR WET BULB TEMPERATURE											
		65				75				85				95				105				115			
		59	63	67	71	59	63	67	71	59	63	67	71	59	63	67	71	59	63	67	71	59	63	67	71
85	MBh	47.5	48.1	49.5	51.6	47.1	47.7	49.1	51.2	45.8	46.5	47.9	50.0	43.8	44.4	45.8	47.9	41.2	41.9	43.3	45.4	38.9	39.6	40.9	43.0
	S/T	1.00	0.89	0.76	0.62	1.00	0.90	0.76	0.62	1.00	1.00	0.79	0.65	1.00	1.00	0.81	0.67	1.00	1.00	0.83	0.69	1.00	1.00	1.00	0.74
	ΔT	31	29	26	22	31	29	25	22	31	29	26	22	31	29	25	22	30	29	25	22	31	30	26	23
	KW	2.77	2.77	2.77	2.79	3.09	3.09	3.08	3.11	3.45	3.45	3.44	3.46	3.83	3.83	3.82	3.85	4.26	4.26	4.25	4.28	4.77	4.76	4.76	4.78
	Amps	10.1	10.1	10.1	10.2	11.6	11.6	11.5	11.6	13.2	13.2	13.2	13.3	14.9	14.9	14.9	15.0	16.9	16.9	16.9	17.0	19.2	19.2	19.2	19.3
	HI PR	259	261	262	267	300	301	303	307	342	344	345	350	388	389	391	396	437	439	440	445	490	491	493	498
	LO PR	126	127	130	136	133	135	138	143	140	141	145	150	145	147	150	155	151	152	155	161	158	159	162	168
	MBh	47.9	48.6	50.0	52.1	47.5	48.2	49.6	51.7	46.3	47.0	48.4	50.5	44.2	44.9	46.3	48.4	41.7	42.4	43.7	45.9	39.4	40.0	41.4	43.5
	S/T	1.00	0.93	0.80	0.66	1.00	1.00	0.81	0.67	1.00	1.00	0.83	0.69	1.00	1.00	0.85	0.71	1.00	1.00	0.87	0.73	1.00	1.00	1.00	0.78
	ΔT	30	28	25	21	30	28	25	21	30	28	25	21	30	28	25	21	30	28	24	21	31	29	26	22
KW	2.79	2.78	2.78	2.80	3.10	3.10	3.10	3.12	3.46	3.46	3.45	3.48	3.84	3.84	3.84	3.86	4.27	4.27	4.27	4.29	4.78	4.78	4.77	4.79	
Amps	10.2	10.2	10.1	10.2	11.6	11.6	11.6	11.7	13.2	13.2	13.2	13.3	15.0	15.0	15.0	15.1	17.0	17.0	16.9	17.0	19.3	19.3	19.2	19.4	
HI PR	261	262	264	268	302	303	305	309	344	345	347	351	390	391	393	397	439	440	442	447	492	493	495	499	
LO PR	127	129	132	137	135	136	139	145	141	143	146	151	147	148	151	157	152	154	157	162	159	161	164	169	
MBh	48.9	49.6	51.0	53.1	48.5	49.2	50.5	52.6	47.3	47.9	49.3	51.4	45.2	45.9	47.2	49.4	42.7	43.3	44.7	46.8	40.3	41.0	42.4	44.5	
S/T	1.00	0.97	0.84	0.70	1.00	1.00	0.85	0.70	1.00	1.00	0.87	0.73	1.00	1.00	0.89	0.75	1.00	1.00	1.00	0.77	1.00	1.00	1.00	0.82	
ΔT	29	27	24	20	29	27	24	20	29	27	24	20	29	27	23	20	28	27	23	20	30	28	24	21	
KW	2.80	2.80	2.80	2.82	3.12	3.12	3.11	3.14	3.48	3.48	3.47	3.49	3.86	3.86	3.85	3.88	4.29	4.29	4.28	4.31	4.80	4.79	4.79	4.81	
Amps	10.2	10.2	10.2	10.3	11.7	11.7	11.7	11.8	13.3	13.3	13.3	13.4	15.1	15.1	15.0	15.2	17.1	17.0	17.0	17.1	19.4	19.3	19.3	19.4	
HI PR	264	265	267	271	304	305	307	312	347	348	350	354	393	394	395	400	442	443	445	449	495	496	497	502	
LO PR	130	131	135	140	137	139	142	147	144	145	149	154	149	151	154	159	155	156	160	165	162	163	166	172	

IDB: Entering Indoor Dry Bulb Temperature
 High and low pressures are measured at the liquid and suction service valves.
 Shaded area reflects AHRI conditions
 kW = Total system power
 Amps = outdoor unit amps (comp.+fan)

IDB		OUTDOOR AMBIENT TEMPERATURE																																															
		65								75								85								95								105								115							
		AIRFLOW						ENTERING INDOOR WET BULB TEMPERATURE						ENTERING INDOOR WET BULB TEMPERATURE						ENTERING INDOOR WET BULB TEMPERATURE						ENTERING INDOOR WET BULB TEMPERATURE						ENTERING INDOOR WET BULB TEMPERATURE																	
59	63	67	71	59	63	67	71	59	63	67	71	59	63	67	71	59	63	67	71	59	63	67	71	59	63	67	71	59	63	67	71	59	63	67	71	59	63	67	71										
70	MBh	58.8	59.6	61.3	-	58.2	59.1	60.8	-	56.7	57.5	59.3	-	54.1	54.9	56.7	-	50.9	51.7	53.5	-	48.0	48.8	50.6	-	58.8	59.6	61.3	-	58.2	59.1	60.8	-	56.7	57.5	59.3	-	54.1	54.9	56.7	-	50.9	51.7	53.5	-	48.0	48.8	50.6	-
	S/T	0.62	0.55	0.42	-	0.62	0.55	0.43	-	0.65	0.58	0.45	-	0.66	0.59	0.47	-	0.69	0.61	0.49	-	1.00	0.66	0.54	-	0.62	0.55	0.42	-	0.62	0.55	0.43	-	0.65	0.58	0.45	-	0.66	0.59	0.47	-	0.69	0.61	0.49	-	1.00	0.66	0.54	-
	ΔT	21	19	15	-	21	19	15	-	21	19	15	-	21	19	15	-	21	19	15	-	22	20	16	-	21	19	15	-	21	19	15	-	21	19	15	-	21	19	15	-	22	20	16	-	22	20	16	-
	KW	3.43	3.42	3.42	-	3.85	3.85	3.84	-	4.33	4.33	4.32	-	4.84	4.84	4.83	-	5.42	5.42	5.41	-	6.09	6.09	6.08	-	3.43	3.42	3.42	-	3.85	3.85	3.84	-	4.33	4.33	4.32	-	4.84	4.84	4.83	-	5.42	5.42	5.41	-	6.09	6.09	6.08	-
	Amps	13.2	13.2	13.1	-	15.1	15.1	15.1	-	17.3	17.3	17.3	-	19.7	19.6	19.6	-	22.3	22.3	22.2	-	25.4	25.4	25.3	-	13.2	13.2	13.1	-	15.1	15.1	15.1	-	17.3	17.3	17.3	-	19.7	19.6	19.6	-	22.3	22.3	22.2	-	25.4	25.4	25.3	-
HI PR	270	271	273	-	312	313	315	-	356	358	359	-	404	405	407	-	455	457	459	-	510	511	513	-	270	271	273	-	312	313	315	-	356	358	359	-	404	405	407	-	455	457	459	-	510	511	513	-	
LO PR	117	118	121	-	124	125	128	-	130	131	134	-	135	136	139	-	140	141	144	-	146	148	151	-	117	118	121	-	124	125	128	-	130	131	134	-	135	136	139	-	140	141	144	-	146	148	151	-	
70	MBh	59.7	60.5	62.3	-	59.2	60.0	61.7	-	57.7	58.5	60.2	-	55.1	55.9	57.6	-	51.9	52.7	54.4	-	49.0	49.8	51.5	-	59.7	60.5	62.3	-	59.2	60.0	61.7	-	57.7	58.5	60.2	-	55.1	55.9	57.6	-	51.9	52.7	54.4	-	49.0	49.8	51.5	-
	S/T	0.65	0.58	0.45	-	0.66	0.58	0.46	-	0.68	0.61	0.48	-	0.70	0.63	0.50	-	0.72	0.65	0.52	-	1.00	0.69	0.57	-	0.65	0.58	0.45	-	0.66	0.58	0.46	-	0.68	0.61	0.48	-	0.70	0.63	0.50	-	0.72	0.65	0.52	-	1.00	0.69	0.57	-
	ΔT	20	18	14	-	20	18	14	-	20	18	14	-	20	18	14	-	19	17	14	-	21	19	15	-	20	18	14	-	20	18	14	-	20	18	14	-	20	18	14	-	19	17	14	-	21	19	15	-
	KW	3.45	3.44	3.43	-	3.87	3.87	3.86	-	4.35	4.34	4.34	-	4.86	4.86	4.85	-	5.44	5.43	5.43	-	6.11	6.11	6.10	-	3.45	3.44	3.43	-	3.87	3.87	3.86	-	4.35	4.34	4.34	-	4.86	4.86	4.85	-	5.44	5.43	5.43	-	6.11	6.11	6.10	-
	Amps	13.3	13.3	13.2	-	15.2	15.2	15.2	-	17.4	17.4	17.3	-	19.8	19.7	19.7	-	22.4	22.4	22.3	-	25.5	25.5	25.4	-	13.3	13.3	13.2	-	15.2	15.2	15.2	-	17.4	17.4	17.3	-	19.8	19.7	19.7	-	22.4	22.4	22.3	-	25.5	25.5	25.4	-
HI PR	272	273	275	-	314	316	318	-	359	360	362	-	406	408	409	-	458	459	461	-	513	514	516	-	272	273	275	-	314	316	318	-	359	360	362	-	406	408	409	-	458	459	461	-	513	514	516	-	
LO PR	118	120	123	-	125	127	130	-	132	133	136	-	137	138	141	-	142	143	146	-	148	150	153	-	118	120	123	-	125	127	130	-	132	133	136	-	137	138	141	-	142	143	146	-	148	150	153	-	
2000	MBh	61.2	62.0	63.7	-	60.6	61.5	63.2	-	59.1	60.0	61.7	-	56.5	57.3	59.1	-	53.3	54.2	55.9	-	50.4	51.3	53.0	-	61.2	62.0	63.7	-	60.6	61.5	63.2	-	59.1	60.0	61.7	-	56.5	57.3	59.1	-	53.3	54.2	55.9	-	50.4	51.3	53.0	-
	S/T	0.66	0.59	0.46	-	0.66	0.59	0.47	-	0.69	0.62	0.49	-	0.71	0.64	0.51	-	1.00	0.66	0.53	-	1.00	0.70	0.58	-	0.66	0.59	0.46	-	0.66	0.59	0.47	-	0.69	0.62	0.49	-	0.71	0.64	0.51	-	1.00	0.66	0.53	-	1.00	0.70	0.58	-
	ΔT	19	17	13	-	19	17	13	-	19	17	13	-	19	17	13	-	18	16	12	-	20	18	14	-	19	17	13	-	19	17	13	-	19	17	13	-	19	17	13	-	18	16	12	-	20	18	14	-
	KW	3.47	3.46	3.46	-	3.89	3.89	3.88	-	4.37	4.37	4.36	-	4.88	4.88	4.87	-	5.46	5.46	5.45	-	6.13	6.13	6.12	-	3.47	3.46	3.46	-	3.89	3.89	3.88	-	4.37	4.37	4.36	-	4.88	4.88	4.87	-	5.46	5.46	5.45	-	6.13	6.13	6.12	-
	Amps	13.4	13.3	13.3	-	15.3	15.3	15.3	-	17.5	17.5	17.4	-	19.8	19.8	19.8	-	22.5	22.5	22.4	-	25.6	25.6	25.5	-	13.4	13.3	13.3	-	15.3	15.3	15.3	-	17.5	17.5	17.4	-	19.8	19.8	19.8	-	22.5	22.5	22.4	-	25.6	25.6	25.5	-
HI PR	275	276	278	-	317	319	320	-	362	363	365	-	409	410	412	-	461	462	464	-	516	517	519	-	275	276	278	-	317	319	320	-	362	363	365	-	409	410	412	-	461	462	464	-	516	517	519	-	
LO PR	121	123	126	-	128	130	133	-	134	136	139	-	140	141	144	-	145	146	149	-	151	152	155	-	121	123	126	-	128	130	133	-	134	136	139	-	140	141	144	-	145	146	149	-	151	152	155	-	
75	MBh	58.8	59.6	61.3	64.0	58.3	59.1	60.8	63.5	56.8	57.6	59.3	62.0	54.1	55.0	56.7	59.3	51.0	51.8	53.5	56.2	48.1	48.9	50.6	53.3	58.8	59.6	61.3	64.0	58.3	59.1	60.8	63.5	56.8	57.6	59.3	62.0	54.1	55.0	56.7	59.3	51.0	51.8	53.5	56.2	48.1	48.9	50.6	53.3
	S/T	0.74	0.67	0.54	0.41	0.74	0.67	0.55	0.41	0.77	0.70	0.57	0.44	1.00	0.71	0.59	0.46	1.00	0.73	0.61	0.48	1.00	0.78	0.66	0.52	0.74	0.67	0.54	0.41	0.74	0.67	0.55	0.41	0.77	0.70	0.57	0.44	1.00	0.71	0.59	0.46	1.00	0.73	0.61	0.48	1.00	0.78	0.66	0.52
	ΔT	25	23	20	16	25	23	19	16	26	24	20	16	25	23	19	16	24	22	18	14	25	23	19	17	25	23	20	16	25	23	19	16	26	24	20	16	25	23	19	16	24	22	18	14	25	23	19	17
	KW	3.42	3.42	3.41	3.45	3.85	3.85	3.84	3.87	4.33	4.32	4.32	4.35	4.84	4.84	4.83	4.86	5.42	5.41	5.41	5.44	6.09	6.09	6.08	6.11	3.42	3.42	3.41	3.45	3.85	3.85	3.84	3.87	4.33	4.32	4.32	4.35	4.84	4.84	4.83	4.86	5.42	5.41	5.41	5.44	6.09	6.09	6.08	6.11
	Amps	13.2	13.1	13.1	13.3	15.1	15.1	15.1	15.2	17.3	17.3	17.2	17.4	19.7	19.6	19.6	19.8	22.3	22.3	22.2	22.4	25.4	25.4	25.3	25.5	13.2	13.1	13.1	13.3	15.1	15.1	15.1	15.2	17.3	17.3	17.2	17.4	19.7	19.6	19.6	19.8	22.3	22.3	22.2	22.4	25.4	25.4	25.3	25.5
HI PR	270	271	273	278	312	314	315	320	357	358	360	364	404	405	407	412	456	457	459	463	511	512	514	518	270	271	273	278	312	314	315	320	357	358	360	364	404	405	407	412	456	457	459	463	511	512	514	518	
LO PR	117	118	121	126	124	125	128	133	130	131	134	139	135	136	139	144	140	141	144	149	146	148	151	155	117	118	121	126	124	125	128	133	130	131	134	139	135	136	139	144	140	141	144	149	146	148	151	155	
75	MBh	59.7	60.6	62.3	64.9	59.2	60.0	61.8	64.4	57.7	58.5	60.3	62.9	55.1	55.9	57.6	60.3	51.9	52.7	54.5	57.1	49.0	49.8	51.6	54.2	59.7	60.6	62.3	64.9	59.2	60.0	61.8	64.4	57.7	58.5	60.3	62.9	55.1	55.9	57.6	60.3	51.9	52.7	54.5	57.1	49.0	49.8	51.6	54.2
	S/T	0.77	0.70	0.57	0.44	0.78	0.70	0.58	0.45	0.80	0.73	0.60	0.47	1.00	0.75	0.62	0.49	1.00	0.77	0.64	0.51	1.00	0.81	0.69	0.56	0.77	0.70	0.57	0.44	0.78	0.70	0.58	0.45	0.80															

IDB		OUTDOOR AMBIENT TEMPERATURE															ENTERING INDOOR WET BULB TEMPERATURE														
		65					75					85					95					105					115				
		59	63	67	71	75	59	63	67	71	75	59	63	67	71	75	59	63	67	71	75	59	63	67	71	75	59	63	67	71	75
80	MBh	59.1	59.9	61.6	64.3	58.6	59.4	61.1	63.8	57.1	57.9	59.6	62.3	54.4	55.3	57.0	59.6	51.3	52.1	53.8	56.5	48.4	49.2	50.9	53.6						
	S/T	0.85	0.78	0.66	0.5	1.00	0.79	0.66	0.53	1.00	0.81	0.69	0.6	1.00	0.83	0.70	0.57	1.00	0.85	0.72	0.6	1.00	1.00	0.77	0.64						
	ΔT	30	28	24	20	30	28	24	20	30	28	24	20	30	28	24	20	30	28	24	20	31	29	25	21						
	KW	3.43	3.42	3.42	3.5	3.85	3.85	3.84	3.87	4.33	4.32	4.32	4.4	4.84	4.84	4.83	4.87	5.42	5.42	5.42	5.4	6.09	6.09	6.08	6.12						
	Amps	13.2	13.2	13.1	13.3	15.1	15.1	15.1	15.2	17.3	17.3	17.3	17.4	19.7	19.6	19.6	19.8	22.3	22.3	22.2	22.4	25.4	25.4	25.3	25.5						
	HI PR	271	272	274	278	313	314	316	321	357	358	360	365	405	406	408	413	456	457	459	464	511	512	514	519						
	LO PR	117	118	121	126	124	125	128	133	130	132	135	139	135	137	140	145	140	142	145	150	147	148	151	156						
	MBh	60.0	60.9	62.6	65.2	59.5	60.3	62.1	64.7	58.0	58.8	60.6	63.2	55.4	56.2	57.9	60.6	52.2	53.0	54.8	57.4	49.3	50.1	51.9	54.5						
	S/T	0.89	0.81	0.69	0.6	1.00	0.82	0.70	0.56	1.00	0.84	0.72	0.6	1.00	0.86	0.74	0.60	1.00	0.88	0.76	0.6	1.00	1.00	0.80	0.67						
	ΔT	29	27	23	19	29	27	23	19	29	27	23	19	29	27	23	19	29	26	23	19	30	28	24	20						
KW	3.44	3.44	3.43	3.5	3.87	3.87	3.86	3.89	4.35	4.34	4.34	4.4	4.86	4.86	4.85	4.88	5.44	5.43	5.43	5.5	6.11	6.11	6.10	6.13							
Amps	13.3	13.2	13.2	13.4	15.2	15.2	15.2	15.3	17.4	17.4	17.3	17.5	19.7	19.7	19.7	19.8	22.4	22.4	22.3	22.5	25.5	25.5	25.4	25.6							
HI PR	273	274	276	281	315	316	318	323	359	361	362	367	407	408	410	415	458	460	462	466	513	514	516	521							
LO PR	119	120	123	128	126	127	130	135	132	134	136	141	137	139	142	146	142	144	147	152	149	150	153	158							
MBh	61.5	62.3	64.1	66.7	61.0	61.8	63.5	66.2	59.5	60.3	62.0	64.7	56.9	57.7	59.4	62.1	53.7	54.5	56.2	58.9	50.8	51.6	53.3	56.0							
S/T	0.89	0.82	0.70	0.6	1.00	0.83	0.70	0.57	1.00	0.85	0.73	0.6	1.00	0.87	0.75	0.61	1.00	1.00	0.77	0.6	1.00	1.00	0.81	0.68							
ΔT	28	26	22	18	28	26	22	18	28	26	22	18	28	26	22	18	27	25	21	18	29	27	23	19							
KW	3.47	3.46	3.46	3.5	3.89	3.89	3.88	3.91	4.37	4.36	4.36	4.4	4.88	4.88	4.87	4.90	5.46	5.46	5.45	5.5	6.13	6.13	6.12	6.16							
Amps	13.4	13.3	13.3	13.5	15.3	15.3	15.3	15.4	17.5	17.5	17.4	17.6	19.8	19.8	19.8	19.9	22.5	22.5	22.4	22.6	25.6	25.6	25.5	25.7							
HI PR	276	277	279	284	318	319	321	326	362	364	365	370	410	411	413	418	461	463	464	469	516	517	519	524							
LO PR	122	123	126	131	129	130	133	138	135	136	139	144	140	142	144	149	145	147	150	154	152	153	156	161							

IDB		OUTDOOR AMBIENT TEMPERATURE															ENTERING INDOOR WET BULB TEMPERATURE														
		65					75					85					95					105					115				
		59	63	67	71	75	59	63	67	71	75	59	63	67	71	75	59	63	67	71	75	59	63	67	71	75	59	63	67	71	75
85	MBh	60.1	60.9	62.6	65.3	59.5	60.4	62.1	64.7	58.0	58.8	60.6	63.2	55.4	56.2	58.0	60.6	52.2	53.1	54.8	57.4	49.3	50.2	51.9	54.5						
	S/T	1.00	0.88	0.75	0.62	1.00	0.88	0.76	0.62	1.00	0.91	0.78	0.65	1.00	1.00	0.80	0.67	1.00	1.00	0.82	0.69	1.00	1.00	0.87	0.73						
	ΔT	34	32	28	24	34	32	28	24	34	32	28	24	34	32	28	24	34	32	28	24	35	33	29	25						
	KW	3.43	3.43	3.42	3.46	3.86	3.86	3.85	3.88	4.34	4.33	4.33	4.36	4.85	4.85	4.84	4.87	5.43	5.42	5.42	5.45	6.10	6.10	6.09	6.12						
	Amps	13.2	13.2	13.2	13.3	15.2	15.1	15.1	15.3	17.3	17.3	17.3	17.4	19.7	19.7	19.7	19.8	22.3	22.3	22.3	22.4	25.4	25.4	25.4	25.5						
	HI PR	272	273	275	280	314	315	317	322	358	360	361	366	406	407	409	414	457	459	460	465	512	513	515	520						
	LO PR	119	120	123	128	126	127	130	135	132	133	136	141	137	138	141	146	142	144	146	151	148	150	153	158						
	MBh	61.0	61.8	63.6	66.2	60.5	61.3	63.0	65.7	59.0	59.8	61.5	64.2	56.4	57.2	58.9	61.6	53.2	54.0	55.7	58.4	50.3	51.1	52.8	55.5						
	S/T	1.00	0.91	0.78	0.65	1.00	0.91	0.79	0.66	1.00	0.94	0.81	0.68	1.00	1.00	0.83	0.70	1.00	1.00	0.85	0.72	1.00	1.00	0.90	0.77						
	ΔT	33	31	27	23	33	31	27	23	33	31	27	23	33	31	27	23	33	31	27	23	34	32	28	24						
KW	3.45	3.45	3.44	3.48	3.88	3.88	3.87	3.90	4.36	4.35	4.34	4.38	4.87	4.87	4.86	4.89	5.45	5.44	5.44	5.47	6.12	6.12	6.11	6.14							
Amps	13.3	13.3	13.3	13.4	15.3	15.2	15.2	15.4	17.4	17.4	17.4	17.5	19.8	19.8	19.7	19.9	22.4	22.4	22.4	22.5	25.5	25.5	25.5	25.6							
HI PR	274	275	277	282	316	318	319	324	361	362	364	368	408	410	411	416	460	461	463	467	515	516	518	522							
LO PR	121	122	125	130	128	129	132	137	134	135	138	143	139	140	143	148	144	145	148	153	150	152	155	160							
MBh	62.5	63.3	65.0	67.7	62.0	62.8	64.5	67.2	60.4	61.3	63.0	65.6	57.8	58.7	60.4	63.0	54.7	55.5	57.2	59.9	51.7	52.6	54.3	56.9							
S/T	1.00	0.92	0.79	0.66	1.00	0.92	0.80	0.67	1.00	1.00	0.82	0.69	1.00	1.00	0.84	0.71	1.00	1.00	0.86	0.73	1.00	1.00	0.91	0.77							
ΔT	32	30	26	22	32	30	26	22	32	30	26	22	32	30	26	22	31	29	26	22	33	31	27	23							
KW	3.47	3.47	3.46	3.50	3.90	3.90	3.89	3.92	4.38	4.37	4.37	4.40	4.89	4.89	4.88	4.91	5.47	5.46	5.46	5.49	6.14	6.14	6.13	6.16							
Amps	13.4	13.4	13.3	13.5	15.3	15.3	15.3	15.4	17.5	17.5	17.5	17.6	19.9	19.9	19.8	20.0	22.5	22.5	22.5	22.6	25.6	25.6	25.6	25.7							
HI PR	277	278	280	285	319	321	322	327	364	365	367	371	411	412	414	419	463	464	466	470	518	519	521	525							
LO PR	124	125	128	133	131	132	135	140	137	138	141	146	142	143	146	151	147	148	151	156	153	155	158	162							

IDB: Entering Indoor Dry Bulb Temperature
 High and low pressures are measured at the liquid and suction service valves.
 Shaded area reflects AHRI conditions
 kW = Total system power
 Amps = outdoor unit amps (comp.+fan)

VSX140181A* / CA*F3636*6** W/.052" ORIFICE CONDITIONS: 80 °F IBD, 67 °F IWB @ 600 CFM				
OUTDOOR TEM. ° F.	TOTAL BTU/H	SENSIBLE BTU/H	LATENT BTU/H	TOTAL WATTS
75	19,300	13,124	6,176	1,220
80	19,050	13,142	5,908	1,290
85	18,800	13,160	5,640	1,360
90	18,400	13,060	5,340	1,435
95	18,000	12,960	5,040	1,510
100	17,500	12,770	4,730	1,595
105	17,000	12,580	4,420	1,680
110	16,550	12,650	3,901	1,780
115	16,100	12,719	3,381	1,880
TVA CONDITIONS @ 95° OD DB, 75° ID DB 63° ID WB				
95°	17,400	12,700	4,700	1,510

VSX140191A* / CA*F3636*6** W/.053" ORIFICE CONDITIONS: 80 °F IBD, 67 °F IWB @ 550 CFM				
OUTDOOR TEM. ° F.	TOTAL BTU/H	SENSIBLE BTU/H	LATENT BTU/H	TOTAL WATTS
75	18,900	13,041	5,859	1,160
80	18,650	13,145	5,506	1,225
85	18,400	13,248	5,152	1,290
90	18,000	13,136	4,864	1,360
95	17,600	13,024	4,576	1,430
100	17,100	12,820	4,280	1,530
105	16,600	12,616	3,984	1,590
110	16,150	12,667	3,484	1,680
115	15,700	12,717	2,983	1,770
TVA CONDITIONS @ 95° OD DB, 75° ID DB 63° ID WB				
95°	17,000	12,750	4,250	1,430

VSX140241A* / CA*F3636*6** W/.057" ORIFICE CONDITIONS: 80 °F IBD, 67 °F IWB @ 700 CFM				
OUTDOOR TEM. ° F.	TOTAL BTU/H	SENSIBLE BTU/H	LATENT BTU/H	TOTAL WATTS
75	24,877	16,961	7,916	1,554
80	24,568	17,040	7,528	1,644
85	24,260	17,120	7,140	1,735
90	23,730	16,961	6,769	1,833
95	23,200	16,802	6,397	1,931
100	22,552	16,564	5,988	2,040
105	21,904	16,326	5,578	2,149
110	21,312	16,393	4,919	2,278
115	20,721	16,461	4,260	2,406
TVA CONDITIONS @ 95° OD DB, 75° ID DB 63° ID WB				
95°	22,400	16,802	5,598	1,931

VSX140251A* / CA*F3636*6** W/.057" ORIFICE CONDITIONS: 80 °F IBD, 67 °F IWB @ 700 CFM				
OUTDOOR TEM. ° F.	TOTAL BTU/H	SENSIBLE BTU/H	LATENT BTU/H	TOTAL WATTS
75	25,500	17,085	8,415	1,570
80	25,200	17,258	7,943	1,660
85	24,900	17,430	7,470	1,750
90	24,350	17,283	7,067	1,850
95	23,800	17,136	6,664	1,950
100	23,150	16,893	6,257	2,060
105	22,500	16,650	5,850	2,170
110	21,900	16,739	5,162	2,300
115	21,300	16,827	4,473	2,430
TVA Conditions @ 95° OD DB, 75° ID DB 63° ID WB				
95°	23,000	16,790	6,210	1,950

VSX140301A* / CA*F3642*6** W/.065" ORIFICE CONDITIONS: 80 °F IBD, 67 °F IWB @ 1000 CFM				
OUTDOOR TEM. ° F.	TOTAL BTU/H	SENSIBLE BTU/H	LATENT BTU/H	TOTAL WATTS
75	30,900	21,630	9,270	1,960
80	30,500	21,651	8,849	2,070
85	30,100	21,672	8,428	2,180
90	29,450	21,492	7,958	2,300
95	28,800	21,312	7,488	2,420
100	28,000	20,992	7,008	2,550
105	27,200	20,672	6,528	2,680
110	26,450	20,745	5,706	2,840
115	25,700	20,817	4,883	3,000
TVA Conditions @ 95° OD DB, 75° ID DB 63° ID WB				
95°	27,800	20,850	6,950	2,420

VSX140311A* / CA*F3137*6** W/.063" ORIFICE CONDITIONS: 80 °F IBD, 67 °F IWB @ 1000 CFM				
OUTDOOR TEM. ° F.	TOTAL BTU/H	SENSIBLE BTU/H	LATENT BTU/H	TOTAL WATTS
75	30,700	22,718	7,982	1,920
80	30,300	22,871	7,430	2,025
85	29,900	23,023	6,877	2,130
90	29,250	22,809	6,442	2,245
95	28,600	22,594	6,006	2,360
100	27,800	22,232	5,568	2,490
105	27,000	21,870	5,130	2,620
110	26,250	21,900	4,350	2,770
115	25,500	21,930	3,570	2,920
TVA Conditions @ 95° OD DB, 75° ID DB 63° ID WB				
95°	27,600	20,080	5,520	2,360

VSX140361A* / CA*F3642*6** W/.068" ORIFICE CONDITIONS: 80 °F IBD, 67 °F IWB @ 1200 CFM				
Outdoor Tem. ° F.	Total Btuh	Sensible Btuh	Latent Btuh	Total Watts
75	36,700	25,690	11,010	2,330
80	36,250	25,733	10,517	2,460
85	35,800	25,776	10,024	2,590
90	35,000	25,542	9,458	2,730
95	34,200	25,308	8,892	2,870
100	33,250	24,928	8,322	3,030
105	32,300	24,548	7,752	3,190
110	31,400	24,627	6,774	3,370
115	30,500	24,705	5,795	3,550
TVA Conditions @ 95° OD DB, 75° ID DB 63° ID WB				
95°	33,000	24,750	8,250	2,870

VSX140371A* / CA*F3137*6** W/.071" ORIFICE CONDITIONS: 80 °F IBD, 67 °F IWB @ 1100 CFM				
Outdoor Tem. ° F.	Total Btuh	Sensible Btuh	Latent Btuh	Total Watts
75	36,500	25,915	10,585	2,260
80	36,050	26,130	9,921	2,400
85	35,600	26,344	9,256	2,540
90	34,800	26,092	8,708	2,675
95	34,000	25,840	8,160	2,810
100	33,050	25,439	7,611	2,970
105	32,100	25,038	7,062	3,130
110	31,250	25,135	6,115	3,315
115	30,400	25,232	5,168	3,500
TVA Conditions @ 95° OD DB, 75° ID DB 63° ID WB				
95°	32,800	25,256	7,544	2,810

VSX140421A* / CA*F4961*6** W/.074" ORIFICE CONDITIONS: 80 °F IBD, 67 °F IWB @ 1400 CFM				
Outdoor Tem. ° F.	Total Btuh	Sensible Btuh	Latent Btuh	Total Watts
75	41,800	30,932	10,868	2,600
80	41,300	31,174	10,126	2,750
85	40,800	31,416	9,384	2,900
90	39,900	31,113	8,787	3,060
95	39,000	30,810	8,190	3,220
100	37,900	30,309	7,591	3,400
105	36,800	29,808	6,992	3,580
110	35,800	30,042	5,758	3,795
115	34,800	30,276	4,524	4,010
TVA Conditions @ 95° OD DB, 75° ID DB 63° ID WB				
95°	37,600	30,080	7,520	3,220

VSX140431A* / CA*F4961*6D* W/.074" ORIFICE CONDITIONS: 80 °F IBD, 67 °F IWB @ 1400 CFM				
Outdoor Tem. ° F.	Total Btuh	Sensible Btuh	Latent Btuh	Total Watts
75	41,800	30,932	10,868	2,600
80	41,300	31,174	10,126	2,750
85	40,800	31,416	9,384	2,900
90	39,900	31,113	8,787	3,060
95	39,000	30,810	8,190	3,220
100	37,900	30,309	7,591	3,400
105	36,800	29,808	6,992	3,580
110	35,800	30,042	5,758	3,795
115	34,800	30,276	4,524	4,010
TVA Conditions @ 95° OD DB, 75° ID DB 63° ID WB				
95°	37,600	30,080	7,520	3,220

VSX140481A* / CA*F4860*6** W/.078" ORIFICE CONDITIONS: 80 °F IBD, 67 °F IWB @ 1400 CFM				
Outdoor Tem. ° F.	Total Btuh	Sensible Btuh	Latent Btuh	Total Watts
75	48,300	31,878	16,422	3,080
80	47,700	32,189	15,511	3,255
85	47,100	32,500	14,600	3,430
90	46,050	32,225	13,825	3,625
95	45,000	31,950	13,050	3,820
100	43,750	31,488	12,263	4,035
105	42,500	31,025	11,475	4,250
110	41,350	31,191	10,160	4,500
115	40,200	31,356	8,844	4,750
TVA Conditions @ 95° OD DB, 75° ID DB 63° ID WB				
95°	43,400	31,248	12,152	3,820

VSX140601A* / CA*F4961*6** W/.088" ORIFICE CONDITIONS: 80 °F IBD, 67 °F IWB @ 1550 CFM				
Outdoor Tem. ° F.	Total Btuh	Sensible Btuh	Latent Btuh	Total Watts
75	61,100	40,326	20,774	3,840
80	60,350	40,725	19,625	4,080
85	59,600	41,124	18,476	4,320
90	58,300	40,512	17,788	4,575
95	57,000	39,900	17,100	4,830
100	55,400	39,318	16,082	5,120
105	53,800	38,736	15,064	5,410
110	52,350	38,965	13,386	5,745
115	50,900	39,193	11,707	6,080
TVA Conditions @ 95° OD DB, 75° ID DB 63° ID WB				
95°	55,000	39,050	15,950	4,840

OUTDOOR UNIT	INDOOR UNITS		COOLING RATINGS				CFM	AHRI #
	COILS/AIR HANDLERS	FURNACES	TOTAL ¹	SENS. ¹	SEER ²	EER ³		
VSX14 0181A*	ARUF25B14A*		17,800	12,800	14.0	11.5	570	7984201
	ASPT24B14A*		18,000	13,000	14.5	12.0	605	7517537
	ASPT30C14A*		18,400	13,300	14.5	12.0	580	7517538
	AVPTC24B14A*		18,000	13,000	14.5	12.0	600	7517539
	AVPTC30C14A*		18,400	13,300	14.5	12.0	615	7517540
	AWUF19XX16A*		17,000	12,200	14.0	11.5	600	8033009
	AWUF31XX16A*		17,400	12,500	14.5	11.5	600	7517541
	AWUF32XX16A*		17,400	12,500	14.5	11.5	600	7517542
	CA*F3636*6D*+EEP+TXV		17,800	12,800	14.0	11.5	600	7517543
	CA*F3636*6D*+MBVC1200*-1A*+TXV		17,800	12,800	14.5	11.5	600	7517565
	CA*F3636*6D*+TXV	A*EC960302BNA*	17,800	12,800	14.5	11.5	575	7517544
	CA*F3636*6D*+TXV	A*EC960402BNA*	17,800	12,800	14.5	11.5	575	7517545
	CA*F3636*6D*+TXV	A*EC960603BNA*	17,800	12,800	14.5	11.5	500	7517546
	CA*F3636*6D*+TXV	A*EC960803BNA*	17,800	12,800	14.5	11.5	540	7517547
	CA*F3636*6D*+TXV	A*VC80604B*B*	18,000	13,000	14.5	11.5	620	7517548
	CA*F3636*6D*+TXV	A*VC960403BNA*	18,000	13,000	14.5	11.5	615	7517549
	CA*F3636*6D*+TXV	A*VC960603BNA*	18,000	13,000	14.5	11.5	625	7517550
	CA*F3636*6D*+TXV	A*VC960803BNA*	18,000	13,000	14.5	11.5	620	7517551
	CA*F3636*6D*+TXV	A*VM970603BNA*	18,000	13,000	14.5	11.5	625	7517552
	CA*F3636*6D*+TXV	A*VM970804CNA*	18,000	13,000	14.5	11.5	620	7517553
	CA*F3636*6D*+TXV	G*E80603B*B*	18,000	13,000	14.5	11.5	670	7517554
	CA*F3636*6D*+TXV	G*EC960302BNA*	17,800	12,800	14.5	11.5	575	7517555
	CA*F3636*6D*+TXV	G*EC960402BNA*	17,800	12,800	14.5	11.5	575	7517556
	CA*F3636*6D*+TXV	G*EC960603BNA*	17,800	12,800	14.5	11.5	500	7517557
	CA*F3636*6D*+TXV	G*EC960803BNA*	17,800	12,800	14.5	11.5	540	7517558
	CA*F3636*6D*+TXV	G*VC80604B*B*	18,000	13,000	14.5	11.5	620	7517559
	CA*F3636*6D*+TXV	G*VC960403BNA*	18,000	13,000	14.5	11.5	615	7517560
	CA*F3636*6D*+TXV	G*VC960603BNA*	18,000	13,000	14.5	11.5	625	7517561
	CA*F3636*6D*+TXV	G*VC960803BNA*	18,000	13,000	14.5	11.5	620	7517562
	CA*F3636*6D*+TXV	G*VM970603BNA*	18,000	13,000	14.5	11.5	625	7517563
	CA*F3636*6D*+TXV	G*VM970804CNA*	18,000	13,000	14.5	11.5	620	7517564
	CA*F3743*6D*+EEP+TXV		18,000	13,000	14.5	11.5	600	7517566
	CAPT3743*4A*	A*EC960302BNA*	17,800	12,800	14.5	11.5	575	7517568
	CAPT3743*4A*	A*EC960402BNA*	17,800	12,800	14.5	11.5	575	7517569
	CAPT3743*4A*	A*EC960603BNA*	17,800	12,800	14.5	11.5	500	7517570
	CAPT3743*4A*	A*EC960803BNA*	17,800	12,800	14.5	11.5	540	7517571
	CAPT3743*4A*	A*VC80604B*B*	18,000	13,000	14.5	11.5	620	7517572
	CAPT3743*4A*	A*VC960403BNA*	18,000	13,000	14.5	11.5	615	7517573
	CAPT3743*4A*	A*VC960603BNA*	18,000	13,000	14.5	11.5	625	7517574
	CAPT3743*4A*	A*VC960803BNA*	18,000	13,000	14.5	11.5	620	7517575
	CAPT3743*4A*	A*VM970603BNA*	18,000	13,000	14.5	11.5	625	7517576
	CAPT3743*4A*	A*VM970804CNA*	18,000	13,000	14.5	11.5	620	7517577
	CAPT3743*4A*	G*E80603B*B*	18,000	13,000	14.5	11.5	670	7517578
	CAPT3743*4A*	G*EC960302BNA*	17,800	12,800	14.5	11.5	575	7517579
	CAPT3743*4A*	G*EC960402BNA*	17,800	12,800	14.5	11.5	575	7517580
	CAPT3743*4A*	G*EC960603BNA*	17,800	12,800	14.5	11.5	500	7517581
	CAPT3743*4A*	G*EC960803BNA*	17,800	12,800	14.5	11.5	540	7517582
	CAPT3743*4A*	G*VC80604B*B*	18,000	13,000	14.5	11.5	620	7517583
	CAPT3743*4A*	G*VC960403BNA*	18,000	13,000	14.5	11.5	615	7517584
	CAPT3743*4A*	G*VC960603BNA*	18,000	13,000	14.5	11.5	625	7517585
CAPT3743*4A*	G*VC960803BNA*	18,000	13,000	14.5	11.5	620	7517586	
CAPT3743*4A*	G*VM970603BNA*	18,000	13,000	14.5	11.5	625	7517587	
CAPT3743*4A*	G*VM970804CNA*	18,000	13,000	14.5	11.5	620	7517588	
CAPT3743*4A*+EEP		17,800	12,800	14.0	11.5	550	7517567	

See Notes on Page 32.

OUTDOOR UNIT	INDOOR UNITS		COOLING RATINGS				CFM	AHRI #
	COILS/AIR HANDLERS	FURNACES	TOTAL ¹	SENS. ¹	SEER ²	EER ³		
VSX14 0181A* (cont.)	CAPT3743*4A*+MBVC1200**-1A*		17,400	12,500	14.5	12.0	535	7517589
	CHPF2430B6C*+EEP+TXV		17,800	12,800	14.0	11.5	600	7517590
	CHPF2430B6C*+MBVC1200**-1A*+TXV		17,800	12,800	14.5	11.5	600	7517591
	CHPF2430B6C*+TXV	A*VC80604B*B*	18,000	13,000	14.5	11.5	620	7517592
	CHPF2430B6C*+TXV	G*VC80604B*B*	18,000	13,000	14.5	11.5	620	7517593
	CHPF3636B6C*+EEP+TXV		18,000	13,000	14.5	11.5	600	7517594
	CHPF3636B6C*+TXV	A*EC960302BNA*	17,800	12,800	14.5	11.5	575	7517595
	CHPF3636B6C*+TXV	A*EC960402BNA*	17,800	12,800	14.5	11.5	575	7517596
	CHPF3636B6C*+TXV	A*EC960603BNA*	17,800	12,800	14.5	11.5	500	7517597
	CHPF3636B6C*+TXV	A*EC960803BNA*	17,800	12,800	14.5	11.5	540	7517598
	CHPF3636B6C*+TXV	A*VC960403BNA*	18,000	13,000	14.5	11.5	615	7517599
	CHPF3636B6C*+TXV	A*VC960603BNA*	18,000	13,000	14.5	11.5	625	7517600
	CHPF3636B6C*+TXV	A*VC960803BNA*	18,000	13,000	14.5	11.5	620	7517601
	CHPF3636B6C*+TXV	A*VM970603BNA*	18,000	13,000	14.5	11.5	625	7517602
	CHPF3636B6C*+TXV	A*VM970804CNA*	18,000	13,000	14.5	11.5	620	7517603
	CHPF3636B6C*+TXV	G*E80603B*B*	18,000	13,000	14.5	11.5	670	7517604
	CHPF3636B6C*+TXV	G*EC960302BNA*	17,800	12,800	14.5	11.5	575	7517605
	CHPF3636B6C*+TXV	G*EC960402BNA*	17,800	12,800	14.5	11.5	575	7517606
	CHPF3636B6C*+TXV	G*EC960603BNA*	17,800	12,800	14.5	11.5	500	7517607
	CHPF3636B6C*+TXV	G*EC960803BNA*	17,800	12,800	14.5	11.5	540	7517608
	CHPF3636B6C*+TXV	G*VC960403BNA*	18,000	13,000	14.5	11.5	615	7517609
	CHPF3636B6C*+TXV	G*VC960603BNA*	18,000	13,000	14.5	11.5	625	7517610
	CHPF3636B6C*+TXV	G*VC960803BNA*	18,000	13,000	14.5	11.5	620	7517611
	CHPF3636B6C*+TXV	G*VM970603BNA*	18,000	13,000	14.5	11.5	625	7517612
	CHPF3636B6C*+TXV	G*VM970804CNA*	18,000	13,000	14.5	11.5	620	7517613
	CSCF3036N6D*+EEP+TXV		17,800	12,800	14.0	11.5	600	7517614
	CSCF3036N6D*+TXV	A*VC80604B*B*	18,000	13,000	14.5	11.5	620	7517615
	CSCF3036N6D*+TXV	G*VC80604B*B*	18,000	13,000	14.5	11.5	620	7517616
	CSCF3036N6D*+TXV	A*EC960302BNA*	17,800	12,800	14.5	11.5	575	7517617
	CSCF3036N6D*+TXV	A*EC960402BNA*	17,800	12,800	14.5	11.5	575	7517618
	CSCF3036N6D*+TXV	A*EC960603BNA*	17,800	12,800	14.5	11.5	500	7517619
	CSCF3036N6D*+TXV	A*EC960803BNA*	17,800	12,800	14.5	11.5	540	7517620
	CSCF3036N6D*+TXV	A*VC960403BNA*	18,000	13,000	14.5	11.5	615	7517621
	CSCF3036N6D*+TXV	A*VC960603BNA*	18,000	13,000	14.5	11.5	625	7517622
	CSCF3036N6D*+TXV	A*VC960803BNA*	18,000	13,000	14.5	11.5	620	7517623
	CSCF3036N6D*+TXV	A*VM970603BNA*	18,000	13,000	14.5	11.5	625	7517624
	CSCF3036N6D*+TXV	A*VM970804CNA*	18,000	13,000	14.5	11.5	620	7517625
	CSCF3036N6D*+TXV	G*EC960302BNA*	17,800	12,800	14.5	11.5	575	7517626
	CSCF3036N6D*+TXV	G*EC960402BNA*	17,800	12,800	14.5	11.5	575	7517627
	CSCF3036N6D*+TXV	G*EC960603BNA*	17,800	12,800	14.5	11.5	500	7517628
	CSCF3036N6D*+TXV	G*EC960803BNA*	17,800	12,800	14.5	11.5	540	7517629
	CSCF3036N6D*+TXV	G*VC960403BNA*	18,000	13,000	14.5	11.5	615	7517630
CSCF3036N6D*+TXV	G*VC960603BNA*	18,000	13,000	14.5	11.5	625	7517631	
CSCF3036N6D*+TXV	G*VC960803BNA*	18,000	13,000	14.5	11.5	620	7517632	
CSCF3036N6D*+TXV	G*VM970603BNA*	18,000	13,000	14.5	11.5	625	7517633	
CSCF3036N6D*+TXV	G*VM970804CNA*	18,000	13,000	14.5	11.5	620	7517634	
CSCF3642N6D*+EEP+TXV		18,000	13,000	14.5	11.5	600	7517635	

¹ BTU/h

² Seasonal Energy Efficiency Ratio; Certified per AHRI 210/240 @ 80°F/ 67°F/ 95°F

³ Energy Efficiency Ratio @ 80°F/ 67°F/ 95°F

NOTES

- Always check the S&R plate for electrical data on the unit being installed.
- When matching the outdoor unit to the indoor unit, use the piston supplied with the outdoor unit or that specified on the piston kit chart supplied with the indoor unit.
- EEP - Order from Service Dept. Part No. B13707-38 or new Solid State Board B13707-35S. Part No. B13707-38 is not interchangeable with B13707-35S. The GMC brand gas furnace contains the EEP cooling time delay.

OUTDOOR UNIT	INDOOR UNITS		COOLING RATINGS				CFM	AHRI #
	COILS/AIR HANDLERS	FURNACES	TOTAL ¹	SENS. ¹	SEER ²	EER ³		
VSX14 0191A*	ARUF25B14A*		17,800	13,100	14.0	12.2	570	7984202
	ASPT24B14A*		17,800	13,100	14.5	12.2	525	7517636
	ASPT30C14A*		18,000	13,300	15.0	12.5	600	7517637
	AVPTC24B14A*		17,800	13,100	14.5	12.2	600	7517638
	AVPTC30C14A*		18,200	13,400	15.0	12.5	615	7517639
	AWUF19XX16A*		17,000	12,600	14.0	12.2	600	8033010
	AWUF31XX16A*		17,200	12,700	15.0	12.5	550	7517640
	AWUF32XX16A*		17,200	12,700	15.0	12.5	550	7517641
	CA*F3636*6D*+EEP+TXV		17,600	13,000	14.0	12.2	550	7517642
	CA*F3636*6D*+MBVC1200**~1A*+TXV		18,000	13,300	15.0	12.5	600	7517643
	CA*F3636*6D*+TXV	A*EC960302BNA*	17,800	13,100	15.0	12.5	575	7517644
	CA*F3636*6D*+TXV	A*EC960402BNA*	17,800	13,100	15.0	12.5	575	7517645
	CA*F3636*6D*+TXV	A*EC960603BNA*	17,800	13,100	15.0	12.5	500	7517646
	CA*F3636*6D*+TXV	A*EC960803BNA*	17,800	13,100	15.0	12.5	540	7517647
	CA*F3636*6D*+TXV	A*VC80604B*B*	17,800	13,100	15.0	12.5	620	7517648
	CA*F3636*6D*+TXV	A*VC960403BNA*	17,800	13,100	15.0	12.5	615	7517649
	CA*F3636*6D*+TXV	A*VC960603BNA*	17,800	13,100	15.0	12.5	625	7517650
	CA*F3636*6D*+TXV	A*VC960803BNA*	17,800	13,100	15.0	12.5	620	7517651
	CA*F3636*6D*+TXV	A*VM970603BNA*	17,800	13,100	15.0	12.5	625	7517652
	CA*F3636*6D*+TXV	A*VM970804CNA*	17,800	13,100	15.0	12.5	620	7517653
	CA*F3636*6D*+TXV	G*E80603B*B*	17,800	13,100	15.0	12.5	600	7517654
	CA*F3636*6D*+TXV	G*EC960302BNA*	17,800	13,100	15.0	12.5	575	7517655
	CA*F3636*6D*+TXV	G*EC960402BNA*	17,800	13,100	15.0	12.5	575	7517656
	CA*F3636*6D*+TXV	G*EC960603BNA*	17,800	13,100	15.0	12.5	500	7517657
	CA*F3636*6D*+TXV	G*EC960803BNA*	17,800	13,100	15.0	12.5	540	7517658
	CA*F3636*6D*+TXV	G*VC80604B*B*	17,800	13,100	15.0	12.5	620	7517659
	CA*F3636*6D*+TXV	G*VC960403BNA*	17,800	13,100	15.0	12.5	615	7517660
	CA*F3636*6D*+TXV	G*VC960603BNA*	17,800	13,100	15.0	12.5	625	7517661
	CA*F3636*6D*+TXV	G*VC960803BNA*	17,800	13,100	15.0	12.5	620	7517662
	CA*F3636*6D*+TXV	G*VM970603BNA*	17,800	13,100	15.0	12.5	625	7517663
	CA*F3636*6D*+TXV	G*VM970804CNA*	17,800	13,100	15.0	12.5	620	7517664
	CA*F3743*6D*+EEP+TXV		18,000	13,300	14.5	12.2	550	7517665
	CAPT3743*4A*	A*EC960302BNA*	17,800	13,100	15.0	12.5	575	7517668
	CAPT3743*4A*	A*EC960402BNA*	17,800	13,100	15.0	12.5	575	7517669
	CAPT3743*4A*	A*EC960603BNA*	17,800	13,100	15.0	12.5	500	7517670
	CAPT3743*4A*	A*EC960803BNA*	17,800	13,100	15.0	12.5	540	7517671
	CAPT3743*4A*	A*VC80604B*B*	17,800	13,100	15.0	12.5	620	7517672
	CAPT3743*4A*	A*VC960403BNA*	17,800	13,100	15.0	12.5	615	7517673
	CAPT3743*4A*	A*VC960603BNA*	17,800	13,100	15.0	12.5	625	7517674
	CAPT3743*4A*	A*VC960803BNA*	17,800	13,100	15.0	12.5	620	7517675
	CAPT3743*4A*	A*VM970603BNA*	17,800	13,100	15.0	12.5	625	7517676
	CAPT3743*4A*	A*VM970804CNA*	17,800	13,100	15.0	12.5	620	7517677
	CAPT3743*4A*	G*E80603B*B*	17,800	13,100	15.0	12.5	600	7517678
	CAPT3743*4A*	G*EC960302BNA*	17,800	13,100	15.0	12.5	575	7517679
	CAPT3743*4A*	G*EC960402BNA*	17,800	13,100	15.0	12.5	575	7517680
	CAPT3743*4A*	G*EC960603BNA*	17,800	13,100	15.0	12.5	500	7517681
	CAPT3743*4A*	G*EC960803BNA*	17,800	13,100	15.0	12.5	540	7517682
	CAPT3743*4A*	G*VC80604B*B*	17,800	13,100	15.0	12.5	620	7517683
	CAPT3743*4A*	G*VC960403BNA*	17,800	13,100	15.0	12.5	615	7517684
	CAPT3743*4A*	G*VC960603BNA*	17,800	13,100	15.0	12.5	625	7517685
CAPT3743*4A*	G*VC960803BNA*	17,800	13,100	15.0	12.5	620	7517686	
CAPT3743*4A*	G*VM970603BNA*	17,800	13,100	15.0	12.5	625	7517687	
CAPT3743*4A*	G*VM970804CNA*	17,800	13,100	15.0	12.5	620	7517688	
CAPT3743*4A*+EEP		17,600	13,000	14.0	12.2	550	7517666	
CAPT3743*4A*+MBVC1200**~1A*		17,800	13,100	15.0	12.5	600	7517667	

See Notes on Page 32.

OUTDOOR UNIT	INDOOR UNITS		COOLING RATINGS				CFM	AHRI #
	COILS/AIR HANDLERS	FURNACES	TOTAL ¹	SENS. ¹	SEER ²	EER ³		
VSX14 0191A* (cont.)	CHPF3636B6C*+EEP+TXV		17,600	13,000	14.5	12.2	550	7517689
	CHPF3636B6C*+MBVC1200*-1A*+TXV		18,200	13,400	15.0	12.5	600	7517690
	CHPF3636B6C*+TXV	A*EC960302BNA*	17,800	13,100	15.0	12.5	575	7517691
	CHPF3636B6C*+TXV	A*EC960402BNA*	17,800	13,100	15.0	12.5	575	7517692
	CHPF3636B6C*+TXV	A*EC960603BNA*	17,800	13,100	15.0	12.5	500	7517693
	CHPF3636B6C*+TXV	A*EC960803BNA*	17,800	13,100	15.0	12.5	540	7517694
	CHPF3636B6C*+TXV	A*VC80604B*B*	17,800	13,100	15.0	12.5	620	7517695
	CHPF3636B6C*+TXV	A*VC960403BNA*	17,800	13,100	15.0	12.5	615	7517696
	CHPF3636B6C*+TXV	A*VC960603BNA*	17,800	13,100	15.0	12.5	625	7517697
	CHPF3636B6C*+TXV	A*VC960803BNA*	17,800	13,100	15.0	12.5	620	7517698
	CHPF3636B6C*+TXV	A*VM970603BNA*	17,800	13,100	15.0	12.5	625	7517699
	CHPF3636B6C*+TXV	A*VM970804CNA*	17,800	13,100	15.0	12.5	620	7517700
	CHPF3636B6C*+TXV	G*E80603B*B*	17,800	13,100	15.0	12.5	600	7517701
	CHPF3636B6C*+TXV	G*EC960302BNA*	17,800	13,100	15.0	12.5	575	7517702
	CHPF3636B6C*+TXV	G*EC960402BNA*	17,800	13,100	15.0	12.5	575	7517703
	CHPF3636B6C*+TXV	G*EC960603BNA*	17,800	13,100	15.0	12.5	500	7517704
	CHPF3636B6C*+TXV	G*EC960803BNA*	17,800	13,100	15.0	12.5	540	7517705
	CHPF3636B6C*+TXV	G*VC80604B*B*	17,800	13,100	15.0	12.5	620	7517706
	CHPF3636B6C*+TXV	G*VC960403BNA*	17,800	13,100	15.0	12.5	615	7517707
	CHPF3636B6C*+TXV	G*VC960603BNA*	17,800	13,100	15.0	12.5	625	7517708
	CHPF3636B6C*+TXV	G*VC960803BNA*	17,800	13,100	15.0	12.5	620	7517709
	CHPF3636B6C*+TXV	G*VM970603BNA*	17,800	13,100	15.0	12.5	625	7517710
	CHPF3636B6C*+TXV	G*VM970804CNA*	17,800	13,100	15.0	12.5	620	7517711
	CSCF3036N6D*+EEP+TXV		17,600	13,000	14.0	12.2	550	7517712
	CSCF3036N6D*+TXV	A*VC80604B*B*	17,800	13,100	15.0	12.5	620	7517713
	CSCF3036N6D*+TXV	A*VC960403BNA*	17,800	13,100	15.0	12.5	615	7517714
	CSCF3036N6D*+TXV	A*VC960603BNA*	17,800	13,100	15.0	12.5	625	7517715
	CSCF3036N6D*+TXV	A*VC960803BNA*	17,800	13,100	15.0	12.5	620	7517716
	CSCF3036N6D*+TXV	A*VM970603BNA*	17,800	13,100	15.0	12.5	625	7517717
	CSCF3036N6D*+TXV	A*VM970804CNA*	17,800	13,100	15.0	12.5	620	7517718
	CSCF3036N6D*+TXV	G*VC80604B*B*	17,800	13,100	15.0	12.5	620	7517719
	CSCF3036N6D*+TXV	G*VC960403BNA*	17,800	13,100	15.0	12.5	615	7517720
	CSCF3036N6D*+TXV	G*VC960603BNA*	17,800	13,100	15.0	12.5	625	7517721
	CSCF3036N6D*+TXV	G*VC960803BNA*	17,800	13,100	15.0	12.5	620	7517722
	CSCF3036N6D*+TXV	G*VM970603BNA*	17,800	13,100	15.0	12.5	625	7517723
	CSCF3036N6D*+TXV	G*VM970804CNA*	17,800	13,100	15.0	12.5	620	7517724
	CSCF3642N6D*+TXV	A*EC960302BNA*	17,800	13,100	15.0	12.5	575	7517725
	CSCF3642N6D*+TXV	A*EC960402BNA*	17,800	13,100	15.0	12.5	575	7517726
	CSCF3642N6D*+TXV	A*EC960603BNA*	17,800	13,100	15.0	12.5	500	7517727
	CSCF3642N6D*+TXV	A*EC960803BNA*	17,800	13,100	15.0	12.5	540	7517728
	CSCF3642N6D*+TXV	G*EC960302BNA*	17,800	13,100	15.0	12.5	575	7517729
	CSCF3642N6D*+TXV	G*EC960402BNA*	17,800	13,100	15.0	12.5	575	7517730
CSCF3642N6D*+TXV	G*EC960603BNA*	17,800	13,100	15.0	12.5	500	7517731	
CSCF3642N6D*+TXV	G*EC960803BNA*	17,800	13,100	15.0	12.5	540	7517732	
VSX14 0241A*	ARUF29B14A*		23,600	17,100	14.0	11.5	860	7984203
	ARUF31B14A*		23,600	17,100	14.0	11.5	870	7984204
	ASPT24B14A*		23,000	16,700	14.0	11.5	810	7517733
	ASPT30C14A*		23,600	17,100	14.5	12.0	845	7517734
	AVPTC24B14A*		23,000	16,700	14.0	11.5	795	7517735
	AVPTC30C14A*		23,600	17,100	14.5	12.0	780	7517736
	AWUF25XX16A*		22,000	15,900	14.0	11.5	750	8033011
	AWUF31XX16A*		23,000	16,700	14.5	11.5	800	7517737
	AWUF32XX16A*		23,000	16,700	14.5	11.5	800	7517738
	CA*F3636*6D*	A*EC960302BNA*	23,400	16,900	14.5	11.5	750	7517768
	CA*F3636*6D*	A*EC960402BNA*	23,400	16,900	14.5	11.5	775	7517769

See Notes on Page 32.

OUTDOOR UNIT	INDOOR UNITS		COOLING RATINGS				CFM	AHRI #
	COILS/AIR HANDLERS	FURNACES	TOTAL ¹	SENS. ¹	SEER ²	EER ³		
VSX14 0241A* (cont.)	CA*F3636*6D*	A*EC960603BNA*	23,400	16,900	14.5	11.5	725	7517770
	CA*F3636*6D*	A*EC960803BNA*	23,400	16,900	14.5	11.5	750	7517771
	CA*F3636*6D*	A*VC80604B*B*	23,600	17,100	14.5	11.5	750	7517772
	CA*F3636*6D*	A*VC80805C*B*	23,600	17,100	14.5	11.5	730	7517773
	CA*F3636*6D*	A*VC960403BNA*	23,600	17,100	14.5	11.5	805	7517774
	CA*F3636*6D*	A*VC960603BNA*	23,600	17,100	14.5	11.5	820	7517775
	CA*F3636*6D*	A*VC960803BNA*	23,600	17,100	14.5	11.5	820	7517776
	CA*F3636*6D*	A*VC960804CNA*	23,600	17,100	14.5	11.5	810	7517777
	CA*F3636*6D*	A*VM970603BNA*	23,600	17,100	14.5	11.5	820	7517778
	CA*F3636*6D*	A*VM970803BNA*	23,600	17,100	14.5	11.5	800	7517779
	CA*F3636*6D*	A*VM970804CNA*	23,600	17,100	14.5	11.5	810	7517780
	CA*F3636*6D*	G*E80603B*B*	23,600	17,100	14.5	11.5	725	7517781
	CA*F3636*6D*	G*EC960302BNA*	23,400	16,900	14.5	11.5	750	7517782
	CA*F3636*6D*	G*EC960402BNA*	23,400	16,900	14.5	11.5	775	7517783
	CA*F3636*6D*	G*EC960603BNA*	23,400	16,900	14.5	11.5	725	7517784
	CA*F3636*6D*	G*EC960803BNA*	23,400	16,900	14.5	11.5	750	7517785
	CA*F3636*6D*	G*VC80604B*B*	23,600	17,100	14.5	11.5	750	7517786
	CA*F3636*6D*	G*VC80805C*B*	23,600	17,100	14.5	11.5	730	7517787
	CA*F3636*6D*	G*VC960403BNA*	23,600	17,100	14.5	11.5	805	7517788
	CA*F3636*6D*	G*VC960603BNA*	23,600	17,100	14.5	11.5	820	7517789
	CA*F3636*6D*	G*VC960803BNA*	23,600	17,100	14.5	11.5	820	7517790
	CA*F3636*6D*	G*VC960804CNA*	23,600	17,100	14.5	11.5	810	7517791
	CA*F3636*6D*	G*VM970603BNA*	23,600	17,100	14.5	11.5	820	7517792
	CA*F3636*6D*	G*VM970803BNA*	23,600	17,100	14.5	11.5	800	7517793
	CA*F3636*6D*	G*VM970804CNA*	23,600	17,100	14.5	11.5	810	7517794
	CA*F3636*6D*+EEP		23,600	17,100	14.0	11.5	725	7517739
	CA*F3636*6D*+EEP+TXV		23,600	17,100	14.0	11.5	725	7517740
	CA*F3636*6D*+MBVC1200**-1A*		23,600	17,100	14.5	12.0	725	7520357
	CA*F3636*6D*+TXV	A*EC960302BNA*	23,400	16,900	14.5	11.5	750	7517741
	CA*F3636*6D*+TXV	A*EC960402BNA*	23,400	16,900	14.5	11.5	775	7517742
	CA*F3636*6D*+TXV	A*EC960603BNA*	23,400	16,900	14.5	11.5	725	7517743
	CA*F3636*6D*+TXV	A*EC960803BNA*	23,400	16,900	14.5	11.5	750	7517744
	CA*F3636*6D*+TXV	A*VC80604B*B*	23,600	17,100	14.5	11.5	750	7517745
	CA*F3636*6D*+TXV	A*VC80805C*B*	23,600	17,100	14.5	11.5	730	7517746
	CA*F3636*6D*+TXV	A*VC960403BNA*	23,600	17,100	14.5	11.5	805	7517747
	CA*F3636*6D*+TXV	A*VC960603BNA*	23,600	17,100	14.5	11.5	820	7517748
	CA*F3636*6D*+TXV	A*VC960803BNA*	23,600	17,100	14.5	11.5	800	7517749
	CA*F3636*6D*+TXV	A*VC960804CNA*	23,600	17,100	14.5	11.5	810	7517750
	CA*F3636*6D*+TXV	A*VM970603BNA*	23,600	17,100	14.5	11.5	820	7517751
	CA*F3636*6D*+TXV	A*VM970803BNA*	23,600	17,100	14.5	11.5	800	7517752
	CA*F3636*6D*+TXV	A*VM970804CNA*	23,600	17,100	14.5	11.5	810	7517753
	CA*F3636*6D*+TXV	G*E80603B*B*	23,600	17,100	14.5	11.5	725	7517754
	CA*F3636*6D*+TXV	G*EC960302BNA*	23,400	16,900	14.5	11.5	750	7517755
	CA*F3636*6D*+TXV	G*EC960402BNA*	23,400	16,900	14.5	11.5	775	7517756
	CA*F3636*6D*+TXV	G*EC960603BNA*	23,400	16,900	14.5	11.5	725	7517757
	CA*F3636*6D*+TXV	G*EC960803BNA*	23,400	16,900	14.5	11.5	750	7517758
	CA*F3636*6D*+TXV	G*VC80604B*B*	23,600	17,100	14.5	11.5	750	7517759
CA*F3636*6D*+TXV	G*VC80805C*B*	23,600	17,100	14.5	11.5	730	7517760	
CA*F3636*6D*+TXV	G*VC960403BNA*	23,600	17,100	14.5	11.5	805	7517761	
CA*F3636*6D*+TXV	G*VC960603BNA*	23,600	17,100	14.5	11.5	820	7517762	
CA*F3636*6D*+TXV	G*VC960803BNA*	23,600	17,100	14.5	11.5	800	7517763	
CA*F3636*6D*+TXV	G*VC960804CNA*	23,600	17,100	14.5	11.5	810	7517764	
CA*F3636*6D*+TXV	G*VM970603BNA*	23,600	17,100	14.5	11.5	820	7517765	
CA*F3636*6D*+TXV	G*VM970803BNA*	23,600	17,100	14.5	11.5	800	7517766	
CA*F3636*6D*+TXV	G*VM970804CNA*	23,600	17,100	14.5	11.5	810	7517767	

See Notes on Page 32.

OUTDOOR UNIT	INDOOR UNITS		COOLING RATINGS				CFM	AHRI #
	COILS/AIR HANDLERS	FURNACES	TOTAL ¹	SENS. ¹	SEER ²	EER ³		
VSX14 0241A* (cont.)	CA*F3642*6D*+EEP		23,600	17,100	14.0	11.5	725	7517795
	CA*F3743*6D*+EEP		23,600	17,100	14.0	11.5	725	7517796
	CA*F3743*6D*+EEP+TXV		23,600	17,100	14.5	12.0	725	7517797
	CAPT3743*4A*	A*EC960302BNA*	23,400	16,900	14.5	11.5	750	7517800
	CAPT3743*4A*	A*EC960402BNA*	23,400	16,900	14.5	11.5	775	7517801
	CAPT3743*4A*	A*EC960603BNA*	23,400	16,900	14.5	11.5	725	7517802
	CAPT3743*4A*	A*EC960803BNA*	23,400	16,900	14.5	11.5	750	7517803
	CAPT3743*4A*	A*VC80604B*B*	23,600	17,100	14.5	11.5	750	7517804
	CAPT3743*4A*	A*VC80805C*B*	23,600	17,100	14.5	11.5	730	7517805
	CAPT3743*4A*	A*VC960403BNA*	23,400	16,900	14.5	11.5	805	7517806
	CAPT3743*4A*	A*VC960603BNA*	23,400	16,900	14.5	11.5	820	7517807
	CAPT3743*4A*	A*VC960803BNA*	23,400	16,900	14.5	11.5	800	7517808
	CAPT3743*4A*	A*VC960804CNA*	23,600	17,100	14.5	11.5	810	7517809
	CAPT3743*4A*	A*VM970603BNA*	23,400	16,900	14.5	11.5	820	7517810
	CAPT3743*4A*	A*VM970803BNA*	23,400	16,900	14.5	11.5	800	7517811
	CAPT3743*4A*	A*VM970804CNA*	23,600	17,100	14.5	11.5	810	7517812
	CAPT3743*4A*	G*E80603B*B*	23,600	17,100	14.5	11.5	725	7517813
	CAPT3743*4A*	G*EC960302BNA*	23,400	16,900	14.5	11.5	750	7517814
	CAPT3743*4A*	G*EC960402BNA*	23,400	16,900	14.5	11.5	775	7517815
	CAPT3743*4A*	G*EC960603BNA*	23,400	16,900	14.5	11.5	725	7517816
	CAPT3743*4A*	G*EC960803BNA*	23,400	16,900	14.5	11.5	750	7517817
	CAPT3743*4A*	G*VC80604B*B*	23,600	17,100	14.5	11.5	750	7517818
	CAPT3743*4A*	G*VC80805C*B*	23,600	17,100	14.5	11.5	730	7517819
	CAPT3743*4A*	G*VC960403BNA*	23,400	16,900	14.5	11.5	805	7517820
	CAPT3743*4A*	G*VC960603BNA*	23,400	16,900	14.5	11.5	820	7517821
	CAPT3743*4A*	G*VC960803BNA*	23,400	16,900	14.5	11.5	800	7517822
	CAPT3743*4A*	G*VC960804CNA*	23,600	17,100	14.5	11.5	810	7517823
	CAPT3743*4A*	G*VM970603BNA*	23,400	16,900	14.5	11.5	820	7517824
	CAPT3743*4A*	G*VM970803BNA*	23,400	16,900	14.5	11.5	800	7517825
	CAPT3743*4A*	G*VM970804CNA*	23,600	17,100	14.5	11.5	810	7517826
	CAPT3743*4A*+EEP		23,000	16,700	14.0	11.5	725	7517798
	CAPT3743*4A*+MBVC1200**.-1A*		23,600	17,100	14.5	12.0	760	7517799
	CHPF3636B6C*	A*EC960302BNA*	23,400	16,900	14.5	11.5	750	7517851
	CHPF3636B6C*	A*EC960402BNA*	23,400	16,900	14.5	11.5	775	7517852
	CHPF3636B6C*	A*EC960603BNA*	23,400	16,900	14.5	11.5	725	7517853
	CHPF3636B6C*	A*EC960803BNA*	23,400	16,900	14.5	11.5	750	7517854
	CHPF3636B6C*	A*VC80604B*B*	23,600	17,100	14.5	11.5	750	7517855
	CHPF3636B6C*	A*VC960403BNA*	23,600	17,100	14.5	11.5	805	7517856
	CHPF3636B6C*	A*VC960603BNA*	23,600	17,100	14.5	11.5	820	7517857
	CHPF3636B6C*	A*VC960803BNA*	23,600	17,100	14.5	11.5	800	7517858
	CHPF3636B6C*	A*VM970603BNA*	23,600	17,100	14.5	11.5	820	7517859
	CHPF3636B6C*	A*VM970803BNA*	23,600	17,100	14.5	11.5	800	7517860
	CHPF3636B6C*	G*E80603B*B*	23,600	17,100	14.5	11.5	725	7517861
	CHPF3636B6C*	G*EC960302BNA*	23,400	16,900	14.5	11.5	750	7517862
	CHPF3636B6C*	G*EC960402BNA*	23,400	16,900	14.5	11.5	775	7517863
	CHPF3636B6C*	G*EC960603BNA*	23,400	16,900	14.5	11.5	725	7517864
	CHPF3636B6C*	G*EC960803BNA*	23,400	16,900	14.5	11.5	750	7517865
	CHPF3636B6C*	G*VC80604B*B*	23,600	17,100	14.5	11.5	750	7517866
	CHPF3636B6C*	G*VC960403BNA*	23,600	17,100	14.5	11.5	805	7517867
	CHPF3636B6C*	G*VC960603BNA*	23,600	17,100	14.5	11.5	820	7517868
CHPF3636B6C*	G*VC960803BNA*	23,600	17,100	14.5	11.5	800	7517869	
CHPF3636B6C*	G*VM970603BNA*	23,600	17,100	14.5	11.5	820	7517870	
CHPF3636B6C*	G*VM970803BNA*	23,600	17,100	14.5	11.5	800	7517871	
CHPF3636B6C*+EEP		23,600	17,100	14.0	11.5	725	7517827	
CHPF3636B6C*+EEP+TXV		23,600	17,100	14.5	11.5	725	7517828	

See Notes on Page 32.

OUTDOOR UNIT	INDOOR UNITS		COOLING RATINGS				CFM	AHRI #
	COILS/AIR HANDLERS	FURNACES	TOTAL ¹	SENS. ¹	SEER ²	EER ³		
VSX14 0241A* (cont.)	CHPF3636B6C*+MBVC1200**~1A*		23,600	17,100	14.5	12.0	725	7517829
	CHPF3636B6C*+TXV	A*EC960302BNA*	23,400	16,900	14.5	11.5	750	7517830
	CHPF3636B6C*+TXV	A*EC960402BNA*	23,400	16,900	14.5	11.5	775	7517831
	CHPF3636B6C*+TXV	A*EC960603BNA*	23,400	16,900	14.5	11.5	725	7517832
	CHPF3636B6C*+TXV	A*EC960803BNA*	23,400	16,900	14.5	11.5	750	7517833
	CHPF3636B6C*+TXV	A*VC80604B*B*	23,600	17,100	14.5	11.5	750	7517834
	CHPF3636B6C*+TXV	A*VC960403BNA*	23,600	17,100	14.5	11.5	805	7517835
	CHPF3636B6C*+TXV	A*VC960603BNA*	23,600	17,100	14.5	11.5	820	7517836
	CHPF3636B6C*+TXV	A*VC960803BNA*	23,600	17,100	14.5	11.5	800	7517837
	CHPF3636B6C*+TXV	A*VM970603BNA*	23,600	17,100	14.5	11.5	820	7517838
	CHPF3636B6C*+TXV	A*VM970803BNA*	23,600	17,100	14.5	11.5	800	7517839
	CHPF3636B6C*+TXV	G*E80603B*B*	23,600	17,100	14.5	11.5	725	7517840
	CHPF3636B6C*+TXV	G*EC960302BNA*	23,400	16,900	14.5	11.5	750	7517841
	CHPF3636B6C*+TXV	G*EC960402BNA*	23,400	16,900	14.5	11.5	775	7517842
	CHPF3636B6C*+TXV	G*EC960603BNA*	23,400	16,900	14.5	11.5	725	7517843
	CHPF3636B6C*+TXV	G*EC960803BNA*	23,400	16,900	14.5	11.5	750	7517844
	CHPF3636B6C*+TXV	G*VC80604B*B*	23,600	17,100	14.5	11.5	750	7517845
	CHPF3636B6C*+TXV	G*VC960403BNA*	23,600	17,100	14.5	11.5	805	7517846
	CHPF3636B6C*+TXV	G*VC960603BNA*	23,600	17,100	14.5	11.5	820	7517847
	CHPF3636B6C*+TXV	G*VC960803BNA*	23,600	17,100	14.5	11.5	800	7517848
	CHPF3636B6C*+TXV	G*VM970603BNA*	23,600	17,100	14.5	11.5	820	7517849
	CHPF3636B6C*+TXV	G*VM970803BNA*	23,600	17,100	14.5	11.5	800	7517850
	CHPF3642C6C*	A*VC80805C*B*	23,600	17,100	14.5	11.5	730	7517880
	CHPF3642C6C*	A*VC960804CNA*	23,600	17,100	14.5	11.5	810	7517881
	CHPF3642C6C*	A*VM970804CNA*	23,600	17,100	14.5	11.5	810	7517882
	CHPF3642C6C*	G*VC80805C*B*	23,600	17,100	14.5	11.5	730	7517883
	CHPF3642C6C*	G*VC960804CNA*	23,600	17,100	14.5	11.5	810	7517884
	CHPF3642C6C*	G*VM970804CNA*	23,600	17,100	14.5	11.5	810	7517885
	CHPF3642C6C*+EEP		23,600	17,100	14.0	11.5	725	7517872
	CHPF3642C6C*+EEP+TXV		23,600	17,100	14.5	11.5	725	7517873
	CHPF3642C6C*+TXV	A*VC80805C*B*	23,600	17,100	14.5	11.5	730	7517874
	CHPF3642C6C*+TXV	A*VC960804CNA*	23,600	17,100	14.5	11.5	810	7517875
	CHPF3642C6C*+TXV	A*VM970804CNA*	23,600	17,100	14.5	11.5	810	7517876
	CHPF3642C6C*+TXV	G*VC80805C*B*	23,600	17,100	14.5	11.5	730	7517877
	CHPF3642C6C*+TXV	G*VC960804CNA*	23,600	17,100	14.5	11.5	810	7517878
	CHPF3642C6C*+TXV	G*VM970804CNA*	23,600	17,100	14.5	11.5	810	7517879
	CSCF3036N6D*	A*EC960302BNA*	23,400	16,900	14.5	11.5	750	7517914
	CSCF3036N6D*	A*EC960402BNA*	23,400	16,900	14.5	11.5	775	7517915
	CSCF3036N6D*	A*EC960603BNA*	23,400	16,900	14.5	11.5	725	7517916
	CSCF3036N6D*	A*EC960803BNA*	23,400	16,900	14.5	11.5	750	7517917
	CSCF3036N6D*	A*VC80604B*B*	23,600	17,100	14.5	11.5	750	7517918
	CSCF3036N6D*	A*VC80805C*B*	23,600	17,100	14.5	11.5	730	7517919
	CSCF3036N6D*	A*VC960403BNA*	23,600	17,100	14.5	11.5	805	7517920
	CSCF3036N6D*	A*VC960603BNA*	23,600	17,100	14.5	11.5	820	7517921
	CSCF3036N6D*	A*VC960803BNA*	23,600	17,100	14.5	11.5	800	7517922
	CSCF3036N6D*	A*VC960804CNA*	23,600	17,100	14.5	11.5	810	7517923
	CSCF3036N6D*	A*VM970603BNA*	23,600	17,100	14.5	11.5	820	7517924
	CSCF3036N6D*	A*VM970803BNA*	23,600	17,100	14.5	11.5	800	7517925
	CSCF3036N6D*	A*VM970804CNA*	23,600	17,100	14.5	11.5	810	7517926
	CSCF3036N6D*	G*EC960302BNA*	23,400	16,900	14.5	11.5	750	7517927
CSCF3036N6D*	G*EC960402BNA*	23,400	16,900	14.5	11.5	775	7517928	
CSCF3036N6D*	G*EC960603BNA*	23,400	16,900	14.5	11.5	725	7517929	
CSCF3036N6D*	G*EC960803BNA*	23,400	16,900	14.5	11.5	750	7517930	
CSCF3036N6D*	G*VC80604B*B*	23,600	17,100	14.5	11.5	750	7517931	
CSCF3036N6D*	G*VC80805C*B*	23,600	17,100	14.5	11.5	730	7517932	

See Notes on Page 32.

OUTDOOR UNIT	INDOOR UNITS		COOLING RATINGS				CFM	AHRI #
	COILS/AIR HANDLERS	FURNACES	TOTAL ¹	SENS. ¹	SEER ²	EER ³		
VSX14 0241A* (cont.)	CSCF3036N6D*	G*VC960403BNA*	23,600	17,100	14.5	11.5	805	7517933
	CSCF3036N6D*	G*VC960603BNA*	23,600	17,100	14.5	11.5	820	7517934
	CSCF3036N6D*	G*VC960803BNA*	23,600	17,100	14.5	11.5	800	7517935
	CSCF3036N6D*	G*VC960804CNA*	23,600	17,100	14.5	11.5	810	7517936
	CSCF3036N6D*	G*VM970603BNA*	23,600	17,100	14.5	11.5	820	7517937
	CSCF3036N6D*	G*VM970803BNA*	23,600	17,100	14.5	11.5	800	7517938
	CSCF3036N6D*	G*VM970804CNA*	23,600	17,100	14.5	11.5	810	7517939
	CSCF3036N6D*+EEP		23,600	17,100	14.0	11.5	800	7517886
	CSCF3036N6D*+EEP+TXV		23,600	17,100	14.0	11.5	800	7517887
	CSCF3036N6D*+TXV	A*EC960302BNA*	23,400	16,900	14.5	11.5	750	7517888
	CSCF3036N6D*+TXV	A*EC960402BNA*	23,400	16,900	14.5	11.5	775	7517889
	CSCF3036N6D*+TXV	A*EC960603BNA*	23,400	16,900	14.5	11.5	725	7517890
	CSCF3036N6D*+TXV	A*EC960803BNA*	23,400	16,900	14.5	11.5	750	7517891
	CSCF3036N6D*+TXV	A*VC80604B*B*	23,600	17,100	14.5	11.5	750	7517892
	CSCF3036N6D*+TXV	A*VC80805C*B*	23,600	17,100	14.5	11.5	730	7517893
	CSCF3036N6D*+TXV	A*VC960403BNA*	23,600	17,100	14.5	11.5	805	7517894
	CSCF3036N6D*+TXV	A*VC960603BNA*	23,600	17,100	14.5	11.5	820	7517895
	CSCF3036N6D*+TXV	A*VC960803BNA*	23,600	17,100	14.5	11.5	800	7517896
	CSCF3036N6D*+TXV	A*VC960804CNA*	23,600	17,100	14.5	11.5	810	7517897
	CSCF3036N6D*+TXV	A*VM970603BNA*	23,600	17,100	14.5	11.5	820	7517898
	CSCF3036N6D*+TXV	A*VM970803BNA*	23,600	17,100	14.5	11.5	800	7517899
	CSCF3036N6D*+TXV	A*VM970804CNA*	23,600	17,100	14.5	11.5	810	7517900
	CSCF3036N6D*+TXV	G*EC960302BNA*	23,400	16,900	14.5	11.5	750	7517901
	CSCF3036N6D*+TXV	G*EC960402BNA*	23,400	16,900	14.5	11.5	775	7517902
	CSCF3036N6D*+TXV	G*EC960603BNA*	23,400	16,900	14.5	11.5	725	7517903
	CSCF3036N6D*+TXV	G*EC960803BNA*	23,400	16,900	14.5	11.5	750	7517904
	CSCF3036N6D*+TXV	G*VC80604B*B*	23,600	17,100	14.5	11.5	750	7517905
	CSCF3036N6D*+TXV	G*VC80805C*B*	23,600	17,100	14.5	11.5	730	7517906
	CSCF3036N6D*+TXV	G*VC960403BNA*	23,600	17,100	14.5	11.5	805	7517907
	CSCF3036N6D*+TXV	G*VC960603BNA*	23,600	17,100	14.5	11.5	820	7517908
	CSCF3036N6D*+TXV	G*VC960803BNA*	23,600	17,100	14.5	11.5	800	7517909
	CSCF3036N6D*+TXV	G*VC960804CNA*	23,600	17,100	14.5	11.5	810	7517910
	CSCF3036N6D*+TXV	G*VM970603BNA*	23,600	17,100	14.5	11.5	820	7517911
	CSCF3036N6D*+TXV	G*VM970803BNA*	23,600	17,100	14.5	11.5	800	7517912
CSCF3036N6D*+TXV	G*VM970804CNA*	23,600	17,100	14.5	11.5	810	7517913	
CSCF3642N6D*+EEP		23,600	17,100	14.0	11.5	725	7517940	
CSCF3642N6D*+EEP+TXV		23,600	17,100	14.0	11.5	725	7517941	
VSX14 0251A*	ARUF29B14A*		23,600	16,900	14.0	12.2	860	7984205
	ARUF31B14A*		23,600	16,900	14.0	12.2	870	7984206
	ASPT24B14A*		23,000	16,500	14.0	12.2	810	7517942
	ASPT30C14A*		23,600	16,900	15.0	12.5	845	7517943
	AVPTC24B14A*		23,000	16,500	14.0	12.2	795	7517944
	AVPTC30C14A*		23,600	16,900	15.0	12.5	780	7517945
	AWUF25XX16A*		22,000	15,800	14.0	12.2	750	8033012
	AWUF31XX16A*		23,000	16,500	14.5	12.2	800	7517946
	AWUF32XX16A*		23,000	16,500	14.5	12.2	800	7517947
	CA*F3636*6D*	A*EC960302BNA*	23,400	16,800	14.5	12.2	750	7517978
	CA*F3636*6D*	A*EC960402BNA*	23,400	16,800	14.5	12.2	775	7517979
	CA*F3636*6D*	A*EC960603BNA*	23,400	16,800	14.5	12.2	775	7517980
	CA*F3636*6D*	A*EC960803BNA*	23,400	16,800	14.5	12.2	750	7517981
	CA*F3636*6D*	A*VC80604B*B*	23,600	16,900	15.0	12.5	750	7517982
	CA*F3636*6D*	A*VC80805C*B*	23,600	16,900	15.0	12.5	725	7517983
	CA*F3636*6D*	A*VC960403BNA*	23,600	16,900	15.0	12.5	805	7517984
	CA*F3636*6D*	A*VC960603BNA*	23,600	16,900	15.0	12.5	820	7517985
	CA*F3636*6D*	A*VC960803BNA*	23,600	16,900	15.0	12.5	820	7517986

See Notes on Page 32.

OUTDOOR UNIT	INDOOR UNITS		COOLING RATINGS				CFM	AHRI #
	COILS/AIR HANDLERS	FURNACES	TOTAL ¹	SENS. ¹	SEER ²	EER ³		
VSX14 0251A* (cont.)	CA*F3636*6D*	A*VC960804CNA*	23,600	16,900	15.0	12.5	810	7517987
	CA*F3636*6D*	A*VM970603BNA*	23,600	16,900	15.0	12.5	820	7517988
	CA*F3636*6D*	A*VM970803BNA*	23,600	16,900	15.0	12.5	800	7517989
	CA*F3636*6D*	A*VM970804CNA*	23,600	16,900	15.0	12.5	810	7517990
	CA*F3636*6D*	G*E80603B*B*	23,600	16,900	15.0	12.5	725	7517991
	CA*F3636*6D*	G*EC960302BNA*	23,400	16,800	14.5	12.2	750	7517992
	CA*F3636*6D*	G*EC960402BNA*	23,400	16,800	14.5	12.2	775	7517993
	CA*F3636*6D*	G*EC960603BNA*	23,400	16,800	14.5	12.2	775	7517994
	CA*F3636*6D*	G*EC960803BNA*	23,400	16,800	14.5	12.2	750	7517995
	CA*F3636*6D*	G*VC80604B*B*	23,600	16,900	15.0	12.5	750	7517996
	CA*F3636*6D*	G*VC80805C*B*	23,600	16,900	15.0	12.5	725	7517997
	CA*F3636*6D*	G*VC960403BNA*	23,600	16,900	15.0	12.5	805	7517998
	CA*F3636*6D*	G*VC960603BNA*	23,600	16,900	15.0	12.5	820	7517999
	CA*F3636*6D*	G*VC960803BNA*	23,600	16,900	15.0	12.5	820	7518000
	CA*F3636*6D*	G*VC960804CNA*	23,600	16,900	15.0	12.5	810	7518001
	CA*F3636*6D*	G*VM970603BNA*	23,600	16,900	15.0	12.5	820	7518002
	CA*F3636*6D*	G*VM970803BNA*	23,600	16,900	15.0	12.5	800	7518003
	CA*F3636*6D*	G*VM970804CNA*	23,600	16,900	15.0	12.5	810	7518004
	CA*F3636*6D*+EEP		23,600	16,900	14.0	12.2	725	7517948
	CA*F3636*6D*+EEP+TXV		23,600	16,900	14.0	12.2	725	7517949
	CA*F3636*6D*+MBVC1200** -1A*		23,600	16,900	15.0	12.5	775	7517950
	CA*F3636*6D*+TXV	A*EC960302BNA*	23,400	16,800	15.0	12.5	750	7517951
	CA*F3636*6D*+TXV	A*EC960402BNA*	23,400	16,800	15.0	12.5	775	7517952
	CA*F3636*6D*+TXV	A*EC960603BNA*	23,400	16,800	15.0	12.5	775	7517953
	CA*F3636*6D*+TXV	A*EC960803BNA*	23,400	16,800	15.0	12.5	750	7517954
	CA*F3636*6D*+TXV	A*VC80604B*B*	23,600	16,900	15.0	12.5	750	7517955
	CA*F3636*6D*+TXV	A*VC80805C*B*	23,600	16,900	15.0	12.5	725	7517956
	CA*F3636*6D*+TXV	A*VC960403BNA*	23,600	16,900	15.0	12.5	805	7517957
	CA*F3636*6D*+TXV	A*VC960603BNA*	23,600	16,900	15.0	12.5	820	7517958
	CA*F3636*6D*+TXV	A*VC960803BNA*	23,600	16,900	15.0	12.5	800	7517959
	CA*F3636*6D*+TXV	A*VC960804CNA*	23,600	16,900	15.0	12.5	810	7517960
	CA*F3636*6D*+TXV	A*VM970603BNA*	23,600	16,900	15.0	12.5	820	7517961
	CA*F3636*6D*+TXV	A*VM970803BNA*	23,600	16,900	15.0	12.5	800	7517962
	CA*F3636*6D*+TXV	A*VM970804CNA*	23,600	16,900	15.0	12.5	810	7517963
	CA*F3636*6D*+TXV	G*E80603B*B*	23,600	16,900	15.0	12.5	725	7517964
	CA*F3636*6D*+TXV	G*EC960302BNA*	23,400	16,800	15.0	12.5	750	7517965
	CA*F3636*6D*+TXV	G*EC960402BNA*	23,400	16,800	15.0	12.5	775	7517966
	CA*F3636*6D*+TXV	G*EC960603BNA*	23,400	16,800	15.0	12.5	775	7517967
	CA*F3636*6D*+TXV	G*EC960803BNA*	23,400	16,800	15.0	12.5	750	7517968
	CA*F3636*6D*+TXV	G*VC80604B*B*	23,600	16,900	15.0	12.5	750	7517969
	CA*F3636*6D*+TXV	G*VC80805C*B*	23,600	16,900	15.0	12.5	725	7517970
	CA*F3636*6D*+TXV	G*VC960403BNA*	23,600	16,900	15.0	12.5	805	7517971
	CA*F3636*6D*+TXV	G*VC960603BNA*	23,600	16,900	15.0	12.5	820	7517972
	CA*F3636*6D*+TXV	G*VC960803BNA*	23,600	16,900	15.0	12.5	800	7517973
	CA*F3636*6D*+TXV	G*VC960804CNA*	23,600	16,900	15.0	12.5	810	7517974
	CA*F3636*6D*+TXV	G*VM970603BNA*	23,600	16,900	15.0	12.5	820	7517975
	CA*F3636*6D*+TXV	G*VM970803BNA*	23,600	16,900	15.0	12.5	800	7517976
	CA*F3636*6D*+TXV	G*VM970804CNA*	23,600	16,900	15.0	12.5	810	7517977
	CA*F3743*6D*+EEP		23,800	17,000	14.0	12.2	725	7518005
	CA*F3743*6D*+EEP+TXV		23,800	17,000	14.5	12.2	725	7518006
CAPT3743*4A*	A*EC960302BNA*	23,400	16,800	14.5	12.2	750	7518009	
CAPT3743*4A*	A*EC960402BNA*	23,400	16,800	14.5	12.2	775	7518010	
CAPT3743*4A*	A*EC960603BNA*	23,400	16,800	14.5	12.2	725	7518011	
CAPT3743*4A*	A*EC960803BNA*	23,400	16,800	14.5	12.2	750	7518012	
CAPT3743*4A*	A*VC80604B*B*	23,600	16,900	15.0	12.5	750	7518013	

See Notes on Page 32.

OUTDOOR UNIT	INDOOR UNITS		COOLING RATINGS				CFM	AHRI #	
	COILS/AIR HANDLERS	FURNACES	TOTAL ¹	SENS. ¹	SEER ²	EER ³			
VSX14 0251A* (cont.)	CAPT3743*4A*	A*VC80805C*B*	23,600	16,900	15.0	12.5	725	7518014	
	CAPT3743*4A*	A*VC960403BNA*	23,400	16,800	15.0	12.5	805	7518015	
	CAPT3743*4A*	A*VC960603BNA*	23,400	16,800	15.0	12.5	820	7518016	
	CAPT3743*4A*	A*VC960803BNA*	23,400	16,800	15.0	12.5	800	7518017	
	CAPT3743*4A*	A*VC960804CNA*	23,600	16,900	15.0	12.5	810	7518018	
	CAPT3743*4A*	A*VM970603BNA*	23,400	16,800	15.0	12.5	820	7518019	
	CAPT3743*4A*	A*VM970803BNA*	23,400	16,800	15.0	12.5	800	7518020	
	CAPT3743*4A*	A*VM970804CNA*	23,600	16,900	15.0	12.5	810	7518021	
	CAPT3743*4A*	G*E80603B*B*	23,600	16,900	15.0	12.5	725	7518022	
	CAPT3743*4A*	G*EC960302BNA*	23,400	16,800	14.5	12.2	750	7518023	
	CAPT3743*4A*	G*EC960402BNA*	23,400	16,800	14.5	12.2	775	7518024	
	CAPT3743*4A*	G*EC960603BNA*	23,400	16,800	14.5	12.2	725	7518025	
	CAPT3743*4A*	G*EC960803BNA*	23,400	16,800	14.5	12.2	750	7518026	
	CAPT3743*4A*	G*VC80604B*B*	23,600	16,900	15.0	12.5	750	7518027	
	CAPT3743*4A*	G*VC80805C*B*	23,600	16,900	15.0	12.5	725	7518028	
	CAPT3743*4A*	G*VC960403BNA*	23,400	16,800	15.0	12.5	805	7518029	
	CAPT3743*4A*	G*VC960603BNA*	23,400	16,800	15.0	12.5	820	7518030	
	CAPT3743*4A*	G*VC960803BNA*	23,400	16,800	15.0	12.5	800	7518031	
	CAPT3743*4A*	G*VC960804CNA*	23,600	16,900	15.0	12.5	810	7518032	
	CAPT3743*4A*	G*VM970603BNA*	23,400	16,800	15.0	12.5	820	7518033	
	CAPT3743*4A*	G*VM970803BNA*	23,400	16,800	15.0	12.5	800	7518034	
	CAPT3743*4A*	G*VM970804CNA*	23,600	16,900	15.0	12.5	810	7518035	
	CAPT3743*4A*+EEP			23,600	16,900	14.0	12.2	725	7518007
	CAPT3743*4A*+MBVC1200**,-1A*			23,600	16,900	14.5	12.2	775	7518008
	CHPF3636B6C*	A*EC960302BNA*	23,400	16,800	14.5	12.2	750	7518060	
	CHPF3636B6C*	A*EC960402BNA*	23,400	16,800	14.5	12.2	775	7518061	
	CHPF3636B6C*	A*EC960603BNA*	23,400	16,800	14.5	12.2	725	7518062	
	CHPF3636B6C*	A*EC960803BNA*	23,400	16,800	14.5	12.2	750	7518063	
	CHPF3636B6C*	A*VC80604B*B*	23,600	16,900	15.0	12.5	750	7518064	
	CHPF3636B6C*	A*VC960403BNA*	23,600	16,900	15.0	12.5	805	7518065	
	CHPF3636B6C*	A*VC960603BNA*	23,600	16,900	15.0	12.5	820	7518066	
	CHPF3636B6C*	A*VC960803BNA*	23,600	16,900	15.0	12.5	800	7518067	
	CHPF3636B6C*	A*VM970603BNA*	23,600	16,900	15.0	12.5	820	7518068	
	CHPF3636B6C*	A*VM970803BNA*	23,600	16,900	15.0	12.5	800	7518069	
	CHPF3636B6C*	G*E80603B*B*	23,600	16,900	15.0	12.5	725	7518070	
	CHPF3636B6C*	G*EC960302BNA*	23,400	16,800	14.5	12.2	750	7518071	
	CHPF3636B6C*	G*EC960402BNA*	23,400	16,800	14.5	12.2	775	7518072	
	CHPF3636B6C*	G*EC960603BNA*	23,400	16,800	14.5	12.2	725	7518073	
	CHPF3636B6C*	G*EC960803BNA*	23,400	16,800	14.5	12.2	750	7518074	
	CHPF3636B6C*	G*VC80604B*B*	23,600	16,900	15.0	12.5	750	7518075	
	CHPF3636B6C*	G*VC960403BNA*	23,600	16,900	15.0	12.5	805	7518076	
	CHPF3636B6C*	G*VC960603BNA*	23,600	16,900	15.0	12.5	820	7518077	
	CHPF3636B6C*	G*VC960803BNA*	23,600	16,900	15.0	12.5	800	7518078	
	CHPF3636B6C*	G*VM970603BNA*	23,600	16,900	15.0	12.5	820	7518079	
	CHPF3636B6C*	G*VM970803BNA*	23,600	16,900	15.0	12.5	800	7518080	
	CHPF3636B6C*+EEP			23,600	16,900	14.0	12.2	725	7518036
	CHPF3636B6C*+EEP+TXV			23,600	16,900	14.5	12.2	725	7518037
	CHPF3636B6C*+MBVC1200**,-1A*			23,600	16,900	15.0	12.5	775	7518038
	CHPF3636B6C*+TXV	A*EC960302BNA*	23,400	16,800	14.5	12.2	750	7518039	
	CHPF3636B6C*+TXV	A*EC960402BNA*	23,400	16,800	14.5	12.2	775	7518040	
CHPF3636B6C*+TXV	A*EC960603BNA*	23,400	16,800	14.5	12.2	725	7518041		
CHPF3636B6C*+TXV	A*EC960803BNA*	23,400	16,800	14.5	12.2	750	7518042		
CHPF3636B6C*+TXV	A*VC80604B*B*	23,600	16,900	15.0	12.5	750	7518043		
CHPF3636B6C*+TXV	A*VC960403BNA*	23,600	16,900	15.0	12.5	805	7518044		
CHPF3636B6C*+TXV	A*VC960603BNA*	23,600	16,900	15.0	12.5	820	7518045		

See Notes on Page 32.

OUTDOOR UNIT	INDOOR UNITS		COOLING RATINGS				CFM	AHRI #
	COILS/AIR HANDLERS	FURNACES	TOTAL ¹	SENS. ¹	SEER ²	EER ³		
VSX14 0251A* (cont.)	CHPF3636B6C*+TXV	A*VC960803BNA*	23,600	16,900	15.0	12.5	800	7518046
	CHPF3636B6C*+TXV	A*VM970603BNA*	23,600	16,900	15.0	12.5	820	7518047
	CHPF3636B6C*+TXV	A*VM970803BNA*	23,600	16,900	15.0	12.5	800	7518048
	CHPF3636B6C*+TXV	G*E80603B*B*	23,600	16,900	15.0	12.5	725	7518049
	CHPF3636B6C*+TXV	G*EC960302BNA*	23,400	16,800	14.5	12.2	750	7518050
	CHPF3636B6C*+TXV	G*EC960402BNA*	23,400	16,800	14.5	12.2	775	7518051
	CHPF3636B6C*+TXV	G*EC960603BNA*	23,400	16,800	14.5	12.2	725	7518052
	CHPF3636B6C*+TXV	G*EC960803BNA*	23,400	16,800	14.5	12.2	750	7518053
	CHPF3636B6C*+TXV	G*VC80604B*B*	23,600	16,900	15.0	12.5	750	7518054
	CHPF3636B6C*+TXV	G*VC960403BNA*	23,600	16,900	15.0	12.5	805	7518055
	CHPF3636B6C*+TXV	G*VC960603BNA*	23,600	16,900	15.0	12.5	820	7518056
	CHPF3636B6C*+TXV	G*VC960803BNA*	23,600	16,900	15.0	12.5	800	7518057
	CHPF3636B6C*+TXV	G*VM970603BNA*	23,600	16,900	15.0	12.5	820	7518058
	CHPF3636B6C*+TXV	G*VM970803BNA*	23,600	16,900	15.0	12.5	800	7518059
	CHPF3642C6C*	A*VC80805C*B*	23,600	16,900	15.0	12.5	725	7518087
	CHPF3642C6C*	A*VC960804CNA*	23,600	16,900	15.0	12.5	810	7518088
	CHPF3642C6C*	A*VM970804CNA*	23,600	16,900	15.0	12.5	810	7518089
	CHPF3642C6C*	G*VC80805C*B*	23,600	16,900	15.0	12.5	725	7518090
	CHPF3642C6C*	G*VC960804CNA*	23,600	16,900	15.0	12.5	810	7518091
	CHPF3642C6C*	G*VM970804CNA*	23,600	16,900	15.0	12.5	810	7518092
	CHPF3642C6C*+TXV	A*VC80805C*B*	23,600	16,900	15.0	12.5	725	7518081
	CHPF3642C6C*+TXV	A*VC960804CNA*	23,600	16,900	15.0	12.5	810	7518082
	CHPF3642C6C*+TXV	A*VM970804CNA*	23,600	16,900	15.0	12.5	810	7518083
	CHPF3642C6C*+TXV	G*VC80805C*B*	23,600	16,900	15.0	12.5	725	7518084
	CHPF3642C6C*+TXV	G*VC960804CNA*	23,600	16,900	15.0	12.5	810	7518085
	CHPF3642C6C*+TXV	G*VM970804CNA*	23,600	16,900	15.0	12.5	810	7518086
	CSCF3036N6D*	A*VC80604B*B*	23,600	16,900	15.0	12.5	750	7518113
	CSCF3036N6D*	A*VC80805C*B*	23,600	16,900	15.0	12.5	725	7518114
	CSCF3036N6D*	A*VC960403BNA*	23,600	16,900	15.0	12.5	805	7518115
	CSCF3036N6D*	A*VC960603BNA*	23,600	16,900	15.0	12.5	820	7518116
	CSCF3036N6D*	A*VC960803BNA*	23,600	16,900	15.0	12.5	800	7518117
	CSCF3036N6D*	A*VC960804CNA*	23,600	16,900	15.0	12.5	810	7518118
	CSCF3036N6D*	A*VM970603BNA*	23,600	16,900	15.0	12.5	820	7518119
	CSCF3036N6D*	A*VM970803BNA*	23,600	16,900	15.0	12.5	800	7518120
	CSCF3036N6D*	A*VM970804CNA*	23,600	16,900	15.0	12.5	810	7518121
	CSCF3036N6D*	G*VC80604B*B*	23,600	16,900	15.0	12.5	750	7518122
	CSCF3036N6D*	G*VC80805C*B*	23,600	16,900	15.0	12.5	725	7518123
	CSCF3036N6D*	G*VC960403BNA*	23,600	16,900	15.0	12.5	805	7518124
	CSCF3036N6D*	G*VC960603BNA*	23,600	16,900	15.0	12.5	820	7518125
	CSCF3036N6D*	G*VC960803BNA*	23,600	16,900	15.0	12.5	800	7518126
	CSCF3036N6D*	G*VC960804CNA*	23,600	16,900	15.0	12.5	810	7518127
	CSCF3036N6D*	G*VM970603BNA*	23,600	16,900	15.0	12.5	820	7518128
	CSCF3036N6D*	G*VM970803BNA*	23,600	16,900	15.0	12.5	800	7518129
	CSCF3036N6D*	G*VM970804CNA*	23,600	16,900	15.0	12.5	810	7518130
	CSCF3036N6D*+EEP		23,200	16,600	14.0	12.2	800	7518093
	CSCF3036N6D*+EEP+TXV		23,200	16,600	14.0	12.2	800	7518094
	CSCF3036N6D*+TXV	A*VC80604B*B*	23,600	16,900	15.0	12.5	750	7518095
	CSCF3036N6D*+TXV	A*VC80805C*B*	23,600	16,900	15.0	12.5	725	7518096
	CSCF3036N6D*+TXV	A*VC960403BNA*	23,600	16,900	15.0	12.5	805	7518097
	CSCF3036N6D*+TXV	A*VC960603BNA*	23,600	16,900	15.0	12.5	820	7518098
CSCF3036N6D*+TXV	A*VC960803BNA*	23,600	16,900	15.0	12.5	800	7518099	
CSCF3036N6D*+TXV	A*VC960804CNA*	23,600	16,900	15.0	12.5	810	7518100	
CSCF3036N6D*+TXV	A*VM970603BNA*	23,600	16,900	15.0	12.5	820	7518101	
CSCF3036N6D*+TXV	A*VM970803BNA*	23,600	16,900	15.0	12.5	800	7518102	
CSCF3036N6D*+TXV	A*VM970804CNA*	23,600	16,900	15.0	12.5	810	7518103	

See Notes on Page 32.

OUTDOOR UNIT	INDOOR UNITS		COOLING RATINGS				CFM	AHRI #	
	COILS/AIR HANDLERS	FURNACES	TOTAL ¹	SENS. ¹	SEER ²	EER ³			
VSX14 0251A* (cont.)	CSCF3036N6D*+TXV	G*VC80604B*B*	23,600	16,900	15.0	12.5	750	7518104	
	CSCF3036N6D*+TXV	G*VC80805C*B*	23,600	16,900	15.0	12.5	725	7518105	
	CSCF3036N6D*+TXV	G*VC960403BNA*	23,600	16,900	15.0	12.5	805	7518106	
	CSCF3036N6D*+TXV	G*VC960603BNA*	23,600	16,900	15.0	12.5	820	7518107	
	CSCF3036N6D*+TXV	G*VC960803BNA*	23,600	16,900	15.0	12.5	800	7518108	
	CSCF3036N6D*+TXV	G*VC960804CNA*	23,600	16,900	15.0	12.5	810	7518109	
	CSCF3036N6D*+TXV	G*VM970603BNA*	23,600	16,900	15.0	12.5	820	7518110	
	CSCF3036N6D*+TXV	G*VM970803BNA*	23,600	16,900	15.0	12.5	800	7518111	
	CSCF3036N6D*+TXV	G*VM970804CNA*	23,600	16,900	15.0	12.5	810	7518112	
	CSCF3642N6D*	A*EC960302BNA*	23,400	16,800	14.5	12.2	750	7518139	
	CSCF3642N6D*	A*EC960402BNA*	23,400	16,800	14.5	12.2	775	7518140	
	CSCF3642N6D*	A*EC960603BNA*	23,400	16,800	14.5	12.2	725	7518141	
	CSCF3642N6D*	A*EC960803BNA*	23,400	16,800	14.5	12.2	750	7518142	
	CSCF3642N6D*	G*EC960302BNA*	23,400	16,800	14.5	12.2	750	7518143	
	CSCF3642N6D*	G*EC960402BNA*	23,400	16,800	14.5	12.2	775	7518144	
	CSCF3642N6D*	G*EC960603BNA*	23,400	16,800	14.5	12.2	725	7518145	
	CSCF3642N6D*	G*EC960803BNA*	23,400	16,800	14.5	12.2	750	7518146	
	CSCF3642N6D*+TXV	A*EC960302BNA*	23,400	16,800	14.5	12.2	750	7518131	
	CSCF3642N6D*+TXV	A*EC960402BNA*	23,400	16,800	14.5	12.2	775	7518132	
	CSCF3642N6D*+TXV	A*EC960603BNA*	23,400	16,800	14.5	12.2	725	7518133	
	CSCF3642N6D*+TXV	A*EC960803BNA*	23,400	16,800	14.5	12.2	750	7518134	
	CSCF3642N6D*+TXV	G*EC960302BNA*	23,400	16,800	14.5	12.2	750	7518135	
	CSCF3642N6D*+TXV	G*EC960402BNA*	23,400	16,800	14.5	12.2	775	7518136	
	CSCF3642N6D*+TXV	G*EC960603BNA*	23,400	16,800	14.5	12.2	725	7518137	
	CSCF3642N6D*+TXV	G*EC960803BNA*	23,400	16,800	14.5	12.2	750	7518138	
	VSX14 0301A*	ARUF31B14A*		28,200	21,000	14.0	11.5	870	7984207
		ASPT36C14A*		29,000	21,400	14.5	12.0	1,010	7518147
		AVPTC36C14A*		29,000	21,400	14.5	12.0	1,085	7518148
AWUF31XX16A*			28,000	20,800	14.0	11.5	950	7518149	
AWUF31XX16A*+TXV			28,400	21,000	14.5	11.5	1,000	7518150	
AWUF32XX16A*			28,000	20,800	14.0	11.5	950	7518151	
AWUF32XX16A*+TXV			28,400	21,000	14.5	11.5	1,000	7518152	
AWUF37XX16B*			28,400	21,000	14.0	11.5	1,000	7518153	
AWUF37XX16B*+TXV			28,600	21,200	14.5	11.5	1,000	7518154	
CA*F3137*6A*+EEP			28,800	21,400	14.0	11.5	1,000	8187509	
CA*F3137*6A*+EEP+TXV			28,800	21,400	14.0	11.5	1,000	8187510	
CA*F3137*6A*+MBVC1200**-.1A*			28,800	21,400	14.5	11.5	950	8187511	
CA*F3137*6A*+MBVC1200**-.1A*+TXV			28,800	21,400	14.5	12.0	950	8187512	
CA*F3137*6A*+TXV		G*E80603B*B*	28,800	21,400	14.5	11.5	1,000	8187513	
CA*F3137*6A*+TXV		G*VC80604B*B*	28,400	21,000	14.5	11.5	1,000	8187514	
CA*F3137*6A*+TXV		G*VC960403BNA*	28,600	21,200	14.5	11.5	1,000	8187515	
CA*F3137*6A*+TXV		G*VC960603BNA*	28,800	21,400	14.5	11.5	1,000	8187516	
CA*F3137*6A*+TXV		G*VC960803BNA*	28,600	21,200	14.5	11.5	950	8187517	
CA*F3137*6A*+TXV		G*VM970603BNA*	28,600	21,200	14.5	11.5	1,000	8187518	
CA*F3137*6A*+TXV		G*EC960302BNA*	28,200	21,000	14.5	11.5	940	8187519	
CA*F3137*6A*+TXV		G*EC960402BNA*	28,200	21,000	14.5	11.5	925	8187520	
CA*F3137*6A*+TXV		G*EC960603BNA*	28,200	21,000	14.5	11.5	965	8187521	
CA*F3137*6A*+TXV		G*EC960803BNA*	28,200	21,000	14.5	11.5	950	8187522	
CA*F3137*6A*+TXV		A*EH800603B*A*	28,800	21,400	14.5	11.5	1,000	8187534	
CA*F3137*6A*+TXV		A*VC80604B*B*	28,400	21,000	14.5	11.5	1,000	8187535	
CA*F3137*6A*+TXV		A*VC960403BNA*	28,600	21,200	14.5	11.5	1,000	8187536	
CA*F3137*6A*+TXV		A*VC960603BNA*	28,800	21,400	14.5	11.5	1,000	8187537	
CA*F3137*6A*+TXV		A*VC960803BNA*	28,600	21,200	14.5	11.5	950	8187538	
CA*F3137*6A*+TXV		A*VM970603BNA*	28,600	21,200	14.5	11.5	1,000	8187539	
CA*F3137*6A*+TXV		A*EC960302BNA*	28,200	21,000	14.5	11.5	940	8187540	

See Notes on Page 69.

OUTDOOR UNIT	INDOOR UNITS		COOLING RATINGS				CFM	AHRI #
	COILS/AIR HANDLERS	FURNACES	TOTAL ¹	SENS. ¹	SEER ²	EER ³		
VSX14 0301A* (cont.)	CA*F3137*6A*+TXV	A*EC960402BNA*	28,200	21,000	14.5	11.5	925	8187541
	CA*F3137*6A*+TXV	A*EC960603BNA*	28,200	21,000	14.5	11.5	965	8187542
	CA*F3137*6A*+TXV	A*EC960803BNA*	28,200	21,000	14.5	11.5	950	8187543
	CA*F3642*6D*	A*VC960804CNA*	28,600	21,200	14.5	11.5	1,000	7518191
	CA*F3642*6D*	A*VM970804CNA*	28,600	21,200	14.5	11.5	1,000	7518192
	CA*F3642*6D*	G*VC960804CNA*	28,600	21,200	14.5	11.5	1,000	7518193
	CA*F3642*6D*	G*VM970804CNA*	28,600	21,200	14.5	11.5	1,000	7518194
	CA*F3642*6D*+EEP		28,800	21,400	14.0	11.5	1,000	7518155
	CA*F3642*6D*+EEP+TXV		28,800	21,400	14.0	11.5	1,000	7518156
	CA*F3642*6D*+MBVC1200**-1A*		28,800	21,400	14.5	11.5	980	7519540
	CA*F3642*6D*+MBVC1200**-1A*+TXV		28,800	21,400	14.5	12.0	980	7518157
	CA*F3642*6D*+MBVC1600**-1A*		28,800	21,400	14.5	11.5	1,000	7518158
	CA*F3642*6D*+MBVC1600**-1A*+TXV		28,800	21,400	14.5	12.0	1,000	7518159
	CA*F3642*6D*+TXV	A*EC960302BNA*	28,200	21,000	14.5	11.5	940	7518160
	CA*F3642*6D*+TXV	A*EC960402BNA*	28,200	21,000	14.5	11.5	925	7518161
	CA*F3642*6D*+TXV	A*EC960603BNA*	28,200	21,000	14.5	11.5	965	7518162
	CA*F3642*6D*+TXV	A*EC960803BNA*	28,200	21,000	14.5	11.5	950	7518163
	CA*F3642*6D*+TXV	A*EC961004CNA*	28,600	21,200	14.5	11.5	1,025	7518164
	CA*F3642*6D*+TXV	A*VC80604B*B*	28,400	21,000	14.5	11.5	1,000	7518165
	CA*F3642*6D*+TXV	A*VC80805C*B*	28,400	21,000	14.5	11.5	990	7518166
	CA*F3642*6D*+TXV	A*VC81005C*B*	28,400	21,000	14.5	11.5	1,000	7518167
	CA*F3642*6D*+TXV	A*VC960403BNA*	28,600	21,200	14.5	11.5	1,000	7518168
	CA*F3642*6D*+TXV	A*VC960603BNA*	28,800	21,400	14.5	11.5	1,040	7518169
	CA*F3642*6D*+TXV	A*VC960803BNA*	28,600	21,200	14.5	11.5	975	7518170
	CA*F3642*6D*+TXV	A*VC960804CNA*	28,600	21,200	14.5	11.5	1,000	7518171
	CA*F3642*6D*+TXV	A*VM970603BNA*	28,600	21,200	14.5	11.5	1,040	7518172
	CA*F3642*6D*+TXV	A*VM970804CNA*	28,600	21,200	14.5	11.5	1,000	7518173
	CA*F3642*6D*+TXV	G*E80603B*B*	28,800	21,400	14.5	11.5	1,050	7518174
	CA*F3642*6D*+TXV	G*E80805C*B*	28,800	21,400	14.5	11.5	1,060	7518175
	CA*F3642*6D*+TXV	G*E81005C*B*	28,800	21,400	14.5	11.5	1,080	7518176
	CA*F3642*6D*+TXV	G*EC960302BNA*	28,200	21,000	14.5	11.5	940	7518177
	CA*F3642*6D*+TXV	G*EC960402BNA*	28,200	21,000	14.5	11.5	925	7518178
	CA*F3642*6D*+TXV	G*EC960603BNA*	28,200	21,000	14.5	11.5	965	7518179
	CA*F3642*6D*+TXV	G*EC960803BNA*	28,200	21,000	14.5	11.5	950	7518180
	CA*F3642*6D*+TXV	G*EC961004CNA*	28,600	21,200	14.5	11.5	1,025	7518181
	CA*F3642*6D*+TXV	G*VC80604B*B*	28,400	21,000	14.5	11.5	1,000	7518182
	CA*F3642*6D*+TXV	G*VC80805C*B*	28,400	21,000	14.5	11.5	990	7518183
	CA*F3642*6D*+TXV	G*VC81005C*B*	28,400	21,000	14.5	11.5	1,000	7518184
	CA*F3642*6D*+TXV	G*VC960403BNA*	28,600	21,200	14.5	11.5	1,000	7518185
	CA*F3642*6D*+TXV	G*VC960603BNA*	28,800	21,400	14.5	11.5	1,040	7518186
	CA*F3642*6D*+TXV	G*VC960803BNA*	28,600	21,200	14.5	11.5	975	7518187
	CA*F3642*6D*+TXV	G*VC960804CNA*	28,600	21,200	14.5	11.5	1,000	7518188
	CA*F3642*6D*+TXV	G*VM970603BNA*	28,600	21,200	14.5	11.5	1,040	7518189
	CA*F3642*6D*+TXV	G*VM970804CNA*	28,600	21,200	14.5	11.5	1,000	7518190
	CA*F3743*6D*	A*VC960804CNA*	28,800	21,400	14.5	11.5	1,000	7518228
	CA*F3743*6D*	A*VM970804CNA*	28,600	21,200	14.5	11.5	1,000	7518229
	CA*F3743*6D*	G*VC960804CNA*	28,800	21,400	14.5	11.5	1,000	7518230
	CA*F3743*6D*	G*VM970804CNA*	28,600	21,200	14.5	11.5	1,000	7518231
	CA*F3743*6D*+EEP		28,800	21,400	14.0	11.5	1,000	7518195
	CA*F3743*6D*+EEP+TXV		28,800	21,400	14.0	11.5	1,000	7518196
CA*F3743*6D*+TXV	A*EC960302BNA*	28,400	21,000	14.5	11.5	940	7518197	
CA*F3743*6D*+TXV	A*EC960402BNA*	28,400	21,000	14.5	11.5	925	7518198	
CA*F3743*6D*+TXV	A*EC960603BNA*	28,400	21,000	14.5	11.5	965	7518199	
CA*F3743*6D*+TXV	A*EC960803BNA*	28,400	21,000	14.5	11.5	950	7518200	
CA*F3743*6D*+TXV	A*EC961004CNA*	28,800	21,400	14.5	11.5	1,025	7518201	

See Notes on Page 69.

OUTDOOR UNIT	INDOOR UNITS		COOLING RATINGS				CFM	AHRI #
	COILS/AIR HANDLERS	FURNACES	TOTAL ¹	SENS. ¹	SEER ²	EER ³		
VSX14 0301A* (cont.)	CA*F3743*6D*+TXV	A*VC80604B*B*	28,600	21,200	14.5	11.5	1,000	7518202
	CA*F3743*6D*+TXV	A*VC80805C*B*	28,600	21,200	14.5	11.5	990	7518203
	CA*F3743*6D*+TXV	A*VC81005C*B*	28,600	21,200	14.5	11.5	1,000	7518204
	CA*F3743*6D*+TXV	A*VC960403BNA*	28,800	21,400	14.5	11.5	1,000	7518205
	CA*F3743*6D*+TXV	A*VC960603BNA*	28,800	21,400	14.5	11.5	1,040	7518206
	CA*F3743*6D*+TXV	A*VC960803BNA*	28,600	21,200	14.5	11.5	975	7518207
	CA*F3743*6D*+TXV	A*VC960804CNA*	28,800	21,400	14.5	11.5	1,000	7518208
	CA*F3743*6D*+TXV	A*VM970603BNA*	28,600	21,200	14.5	11.5	1,040	7518209
	CA*F3743*6D*+TXV	A*VM970804CNA*	28,600	21,200	14.5	11.5	1,000	7518210
	CA*F3743*6D*+TXV	G*E80603B*B*	28,800	21,400	14.5	12.0	1,050	7518211
	CA*F3743*6D*+TXV	G*E80805C*B*	28,800	21,400	14.5	12.0	1,060	7518212
	CA*F3743*6D*+TXV	G*E81005C*B*	28,800	21,400	14.5	11.5	1,080	7518213
	CA*F3743*6D*+TXV	G*EC960302BNA*	28,400	21,000	14.5	11.5	940	7518214
	CA*F3743*6D*+TXV	G*EC960402BNA*	28,400	21,000	14.5	11.5	925	7518215
	CA*F3743*6D*+TXV	G*EC960603BNA*	28,400	21,000	14.5	11.5	965	7518216
	CA*F3743*6D*+TXV	G*EC960803BNA*	28,400	21,000	14.5	11.5	950	7518217
	CA*F3743*6D*+TXV	G*EC961004CNA*	28,800	21,400	14.5	11.5	1,025	7518218
	CA*F3743*6D*+TXV	G*VC80604B*B*	28,600	21,200	14.5	11.5	1,000	7518219
	CA*F3743*6D*+TXV	G*VC80805C*B*	28,600	21,200	14.5	11.5	990	7518220
	CA*F3743*6D*+TXV	G*VC81005C*B*	28,600	21,200	14.5	11.5	1,000	7518221
	CA*F3743*6D*+TXV	G*VC960403BNA*	28,800	21,400	14.5	11.5	1,000	7518222
	CA*F3743*6D*+TXV	G*VC960603BNA*	28,800	21,400	14.5	11.5	1,040	7518223
	CA*F3743*6D*+TXV	G*VC960803BNA*	28,600	21,200	14.5	11.5	975	7518224
	CA*F3743*6D*+TXV	G*VC960804CNA*	28,800	21,400	14.5	11.5	1,000	7518225
	CA*F3743*6D*+TXV	G*VM970603BNA*	28,600	21,200	14.5	11.5	1,040	7518226
	CA*F3743*6D*+TXV	G*VM970804CNA*	28,600	21,200	14.5	11.5	1,000	7518227
	CAPT3743*4A*	A*EC960302BNA*	28,200	21,000	14.5	11.5	940	7518235
	CAPT3743*4A*	A*EC960402BNA*	28,200	21,000	14.5	11.5	925	7518236
	CAPT3743*4A*	A*EC960603BNA*	28,200	21,000	14.5	11.5	965	7518237
	CAPT3743*4A*	A*EC960803BNA*	28,200	21,000	14.5	11.5	950	7518238
	CAPT3743*4A*	A*EC961004CNA*	28,600	21,200	14.5	11.5	1,025	7518239
	CAPT3743*4A*	A*VC80604B*B*	28,400	21,000	14.5	11.5	1,000	7518240
	CAPT3743*4A*	A*VC80805C*B*	28,400	21,000	14.5	11.5	990	7518241
	CAPT3743*4A*	A*VC81005C*B*	28,400	21,000	14.5	11.5	1,000	7518242
	CAPT3743*4A*	A*VC960403BNA*	28,600	21,200	14.5	11.5	1,000	7518243
	CAPT3743*4A*	A*VC960603BNA*	28,600	21,200	14.5	11.5	1,040	7518244
	CAPT3743*4A*	A*VC960803BNA*	28,400	21,000	14.5	11.5	975	7518245
	CAPT3743*4A*	A*VC960804CNA*	28,600	21,200	14.5	11.5	1,000	7518246
	CAPT3743*4A*	A*VM970603BNA*	28,600	21,200	14.5	11.5	1,040	7518247
	CAPT3743*4A*	A*VM970804CNA*	28,600	21,200	14.5	11.5	1,000	7518248
	CAPT3743*4A*	G*E80603B*B*	28,800	21,400	14.5	11.5	1,050	7518249
	CAPT3743*4A*	G*E80805C*B*	28,800	21,400	14.5	11.5	1,060	7518250
	CAPT3743*4A*	G*E81005C*B*	28,800	21,400	14.5	11.5	1,080	7518251
	CAPT3743*4A*	G*EC960302BNA*	28,200	21,000	14.5	11.5	940	7518252
	CAPT3743*4A*	G*EC960402BNA*	28,200	21,000	14.5	11.5	925	7518253
	CAPT3743*4A*	G*EC960603BNA*	28,200	21,000	14.5	11.5	965	7518254
	CAPT3743*4A*	G*EC960803BNA*	28,200	21,000	14.5	11.5	950	7518255
	CAPT3743*4A*	G*EC961004CNA*	28,600	21,200	14.5	11.5	1,025	7518256
CAPT3743*4A*	G*VC80604B*B*	28,400	21,000	14.5	11.5	1,000	7518257	
CAPT3743*4A*	G*VC80805C*B*	28,400	21,000	14.5	11.5	990	7518258	
CAPT3743*4A*	G*VC81005C*B*	28,400	21,000	14.5	11.5	1,000	7518259	
CAPT3743*4A*	G*VC960403BNA*	28,600	21,200	14.5	11.5	1,000	7518260	
CAPT3743*4A*	G*VC960603BNA*	28,600	21,200	14.5	11.5	1,040	7518261	
CAPT3743*4A*	G*VC960803BNA*	28,400	21,000	14.5	11.5	975	7518262	
CAPT3743*4A*	G*VC960804CNA*	28,600	21,200	14.5	11.5	1,000	7518263	

See Notes on Page 69.

OUTDOOR UNIT	INDOOR UNITS		COOLING RATINGS				CFM	AHRI #
	COILS/AIR HANDLERS	FURNACES	TOTAL ¹	SENS. ¹	SEER ²	EER ³		
VSX14 0301A* (cont.)	CAPT3743*4A*	G*VM970603BNA*	28,600	21,200	14.5	11.5	1,040	7518264
	CAPT3743*4A*	G*VM970804CNA*	28,600	21,200	14.5	11.5	1,000	7518265
	CAPT3743*4A*+EEP		28,800	21,400	14.5	11.5	1,000	7518232
	CAPT3743*4A*+MBVC1200**_1A*		28,800	21,400	14.5	12.0	980	7518233
	CAPT3743*4A*+MBVC1600**_1A*		28,800	21,400	14.5	12.0	1,000	7518234
	CHPF3636B6C*+TXV	A*VC960403BNA*	28,800	21,400	14.5	11.5	1,000	7518266
	CHPF3636B6C*+TXV	A*VC960603BNA*	28,800	21,400	14.5	11.5	1,040	7518267
	CHPF3636B6C*+TXV	A*VC960803BNA*	28,600	21,200	14.5	11.5	975	7518268
	CHPF3636B6C*+TXV	A*VM970603BNA*	28,600	21,200	14.5	11.5	1,040	7518269
	CHPF3636B6C*+TXV	G*VC960403BNA*	28,800	21,400	14.5	11.5	1,000	7518270
	CHPF3636B6C*+TXV	G*VC960603BNA*	28,800	21,400	14.5	11.5	1,040	7518271
	CHPF3636B6C*+TXV	G*VC960803BNA*	28,600	21,200	14.5	11.5	975	7518272
	CHPF3636B6C*+TXV	G*VM970603BNA*	28,600	21,200	14.5	11.5	1,040	7518273
	CHPF3642C6C*	A*VC960804CNA*	28,800	21,400	14.5	11.5	1,000	7518302
	CHPF3642C6C*	A*VM970804CNA*	28,600	21,200	14.5	11.5	1,000	7518303
	CHPF3642C6C*	G*VC960804CNA*	28,800	21,400	14.5	11.5	1,000	7518304
	CHPF3642C6C*	G*VM970804CNA*	28,600	21,200	14.5	11.5	1,000	7518305
	CHPF3642C6C*+EEP		28,800	21,400	14.0	11.5	1,000	7518274
	CHPF3642C6C*+EEP+TXV		28,800	21,400	14.0	11.5	1,000	7518275
	CHPF3642C6C*+MBVC1200**_1A*		28,800	21,400	14.5	12.0	1,000	7519541
	CHPF3642C6C*+MBVC1200**_1A*+TXV		28,800	21,400	14.5	12.0	1,000	7518276
	CHPF3642C6C*+MBVC1600**_1A*		28,800	21,400	14.5	12.0	1,000	7518277
	CHPF3642C6C*+MBVC1600**_1A*+TXV		28,800	21,400	14.5	12.0	1,000	7518278
	CHPF3642C6C*+TXV	A*EC960302BNA*	28,400	21,000	14.5	11.5	940	7518279
	CHPF3642C6C*+TXV	A*EC960402BNA*	28,400	21,000	14.5	11.5	925	7518280
	CHPF3642C6C*+TXV	A*EC960603BNA*	28,400	21,000	14.5	11.5	965	7518281
	CHPF3642C6C*+TXV	A*EC960803BNA*	28,400	21,000	14.5	11.5	950	7518282
	CHPF3642C6C*+TXV	A*EC961004CNA*	28,800	21,400	14.5	11.5	1,025	7518283
	CHPF3642C6C*+TXV	A*VC80604B*B*	28,600	21,200	14.5	11.5	1,000	7518284
	CHPF3642C6C*+TXV	A*VC80805C*B*	28,600	21,200	14.5	11.5	990	7518285
	CHPF3642C6C*+TXV	A*VC81005C*B*	28,600	21,200	14.5	11.5	1,000	7518286
	CHPF3642C6C*+TXV	A*VC960804CNA*	28,800	21,400	14.5	11.5	1,000	7518287
	CHPF3642C6C*+TXV	A*VM970804CNA*	28,600	21,200	14.5	11.5	1,000	7518288
	CHPF3642C6C*+TXV	G*E80603B*B*	28,800	21,400	14.5	11.5	1,050	7518289
	CHPF3642C6C*+TXV	G*E80805C*B*	28,800	21,400	14.5	11.5	1,000	7518290
	CHPF3642C6C*+TXV	G*E81005C*B*	28,800	21,400	14.5	11.5	1,080	7518291
	CHPF3642C6C*+TXV	G*EC960302BNA*	28,400	21,000	14.5	11.5	940	7518292
	CHPF3642C6C*+TXV	G*EC960402BNA*	28,400	21,000	14.5	11.5	925	7518293
	CHPF3642C6C*+TXV	G*EC960603BNA*	28,400	21,000	14.5	11.5	965	7518294
	CHPF3642C6C*+TXV	G*EC960803BNA*	28,400	21,000	14.5	11.5	950	7518295
	CHPF3642C6C*+TXV	G*EC961004CNA*	28,800	21,400	14.5	11.5	1,025	7518296
	CHPF3642C6C*+TXV	G*VC80604B*B*	28,600	21,200	14.5	11.5	1,000	7518297
	CHPF3642C6C*+TXV	G*VC80805C*B*	28,600	21,200	14.5	11.5	990	7518298
	CHPF3642C6C*+TXV	G*VC81005C*B*	28,600	21,200	14.5	11.5	1,000	7518299
	CHPF3642C6C*+TXV	G*VC960804CNA*	28,800	21,400	14.5	11.5	1,000	7518300
	CHPF3642C6C*+TXV	G*VM970804CNA*	28,600	21,200	14.5	11.5	1,000	7518301
	CHPF3743C6B*+EEP		28,800	21,400	14.0	11.5	1,000	7518306
	CHPF3743C6B*+EEP+TXV		28,800	21,400	14.0	11.5	1,000	7518307
	CHPF3743D6B*+EEP		28,800	21,400	14.0	11.5	1,000	7518308
	CHPF3743D6B*+EEP+TXV		28,800	21,400	14.0	11.5	1,000	7518309
	CSCF3642N6D*	A*VC960804CNA*	28,800	21,400	14.5	11.5	1,000	7518342
	CSCF3642N6D*	A*VM970804CNA*	28,600	21,200	14.5	11.5	1,000	7518343
CSCF3642N6D*	G*VC960804CNA*	28,800	21,400	14.5	11.5	1,000	7518344	
CSCF3642N6D*	G*VM970804CNA*	28,600	21,200	14.5	11.5	1,000	7518345	
CSCF3642N6D*+EEP		28,600	21,200	14.0	11.5	1,000	7518310	

See Notes on Page 69.

OUTDOOR UNIT	INDOOR UNITS		COOLING RATINGS				CFM	AHRI #
	COILS/AIR HANDLERS	FURNACES	TOTAL ¹	SENS. ¹	SEER ²	EER ³		
VSX14 0301A* (cont.)	CSCF3642N6D*+EEP+TXV		28,600	21,200	14.0	11.5	1,000	7518311
	CSCF3642N6D*+TXV	A*EC960302BNA*	28,200	21,000	14.5	11.5	940	7518312
	CSCF3642N6D*+TXV	A*EC960402BNA*	28,200	21,000	14.5	11.5	925	7518313
	CSCF3642N6D*+TXV	A*EC960603BNA*	28,200	21,000	14.5	11.5	965	7518314
	CSCF3642N6D*+TXV	A*EC960803BNA*	28,400	21,000	14.5	11.5	950	7518315
	CSCF3642N6D*+TXV	A*EC961004CNA*	28,400	21,000	14.5	11.5	1,025	7518316
	CSCF3642N6D*+TXV	A*VC80604B*B*	28,600	21,200	14.5	11.5	1,000	7518317
	CSCF3642N6D*+TXV	A*VC80805C*B*	28,600	21,200	14.5	11.5	990	7518318
	CSCF3642N6D*+TXV	A*VC81005C*B*	28,600	21,200	14.5	11.5	1,000	7518319
	CSCF3642N6D*+TXV	A*VC960403BNA*	28,800	21,400	14.5	11.5	1,000	7518320
	CSCF3642N6D*+TXV	A*VC960603BNA*	28,800	21,400	14.5	11.5	1,040	7518321
	CSCF3642N6D*+TXV	A*VC960803BNA*	28,600	21,200	14.5	11.5	975	7518322
	CSCF3642N6D*+TXV	A*VC960804CNA*	28,800	21,400	14.5	11.5	1,000	7518323
	CSCF3642N6D*+TXV	A*VM970603BNA*	28,600	21,200	14.5	11.5	1,040	7518324
	CSCF3642N6D*+TXV	A*VM970804CNA*	28,600	21,200	14.5	11.5	1,000	7518325
	CSCF3642N6D*+TXV	G*E80603B*B*	28,800	21,400	14.5	11.5	1,050	7518326
	CSCF3642N6D*+TXV	G*E80805C*B*	28,800	21,400	14.5	11.5	1,060	7518327
	CSCF3642N6D*+TXV	G*EC960302BNA*	28,200	21,000	14.5	11.5	940	7518328
	CSCF3642N6D*+TXV	G*EC960402BNA*	28,200	21,000	14.5	11.5	925	7518329
	CSCF3642N6D*+TXV	G*EC960603BNA*	28,200	21,000	14.5	11.5	965	7518330
	CSCF3642N6D*+TXV	G*EC960803BNA*	28,400	21,000	14.5	11.5	950	7518331
	CSCF3642N6D*+TXV	G*EC961004CNA*	28,400	21,000	14.5	11.5	1,025	7518332
	CSCF3642N6D*+TXV	G*VC80604B*B*	28,600	21,200	14.5	11.5	1,000	7518333
	CSCF3642N6D*+TXV	G*VC80805C*B*	28,600	21,200	14.5	11.5	990	7518334
	CSCF3642N6D*+TXV	G*VC81005C*B*	28,600	21,200	14.5	11.5	1,000	7518335
	CSCF3642N6D*+TXV	G*VC960403BNA*	28,800	21,400	14.5	11.5	1,000	7518336
	CSCF3642N6D*+TXV	G*VC960603BNA*	28,800	21,400	14.5	11.5	1,040	7518337
	CSCF3642N6D*+TXV	G*VC960803BNA*	28,600	21,200	14.5	11.5	975	7518338
	CSCF3642N6D*+TXV	G*VC960804CNA*	28,800	21,400	14.5	11.5	1,000	7518339
	CSCF3642N6D*+TXV	G*VM970603BNA*	28,600	21,200	14.5	11.5	1,040	7518340
CSCF3642N6D*+TXV	G*VM970804CNA*	28,600	21,200	14.5	11.5	1,000	7518341	
CSCF3642N6D*+TXV	G*E81005C*B*	28,600	21,200	14.5	11.5	1,070	7520358	
VSX14 0311A*	ARUF31B14A*		28,200	22,200	14.0	12.2	870	7984208
	ARUF37C14A*		28,400	22,400	14.0	12.2	1,050	7984209
	ASPT36C14A*		28,000	22,000	15.0	12.5	1,010	7518346
	AVPTC36C14A*		28,000	22,000	15.0	12.5	1,000	7518347
	AWUF31XX16A*		28,000	22,000	14.0	12.2	1,000	7518348
	AWUF31XX16A*+TXV		28,000	22,000	14.5	12.2	1,000	7518349
	AWUF32XX16A*		28,000	22,000	14.0	12.2	950	7518350
	AWUF32XX16A*+TXV		28,000	22,000	14.5	12.2	950	7518351
	AWUF37XX16B*		28,000	22,000	14.0	12.2	950	7518352
	AWUF37XX16B*+TXV		28,000	22,000	14.5	12.2	950	7518353
	CA*F3137*6A*	A*EC960302BNA*	28,200	22,200	15.0	12.5	940	7520359
	CA*F3137*6A*	A*EC960402BNA*	28,200	22,200	15.0	12.5	925	7520360
	CA*F3137*6A*	A*EC960603BNA*	28,200	22,200	15.0	12.5	965	7520361
	CA*F3137*6A*	A*EC960803BNA*	28,200	22,200	15.0	12.5	950	7520362
	CA*F3137*6A*	A*VC80604B*B*	28,400	22,400	15.0	12.5	1,000	7520364
	CA*F3137*6A*	A*VC960403BNA*	28,600	22,600	15.0	12.5	1,000	7520367
	CA*F3137*6A*	A*VC960603BNA*	28,600	22,600	15.0	12.5	1,040	7520368
	CA*F3137*6A*	A*VC960803BNA*	28,400	22,400	15.0	12.5	975	7520369
	CA*F3137*6A*	A*VM970603BNA*	28,400	22,400	15.0	12.5	1,040	7520370
	CA*F3137*6A*	G*E80603B*B*	28,400	22,400	14.5	12.2	1,050	7520371
	CA*F3137*6A*	G*EC960302BNA*	28,200	22,200	15.0	12.5	940	7520374
	CA*F3137*6A*	G*EC960402BNA*	28,200	22,200	15.0	12.5	925	7520375
	CA*F3137*6A*	G*EC960603BNA*	28,200	22,200	15.0	12.5	965	7520376

See Notes on Page 69.

OUTDOOR UNIT	INDOOR UNITS		COOLING RATINGS				CFM	AHRI #
	COILS/AIR HANDLERS	FURNACES	TOTAL ¹	SENS. ¹	SEER ²	EER ³		
VSX14 0311A* (cont.)	CA*F3137*6A*	G*EC960803BNA*	28,200	22,200	15.0	12.5	950	7520377
	CA*F3137*6A*	G*VC80604B*B*	28,400	22,400	15.0	12.5	1,000	7520379
	CA*F3137*6A*	G*VC960403BNA*	28,600	22,600	15.0	12.5	1,000	7520382
	CA*F3137*6A*	G*VC960603BNA*	28,600	22,600	15.0	12.5	1,040	7520383
	CA*F3137*6A*	G*VC960803BNA*	28,400	22,400	15.0	12.5	975	7520384
	CA*F3137*6A*	G*VM970603BNA*	28,400	22,400	15.0	12.5	1,040	7520385
	CA*F3137*6A*+EEP		28,600	22,600	14.0	12.2	1,000	7518358
	CA*F3137*6A*+EEP+TXV		28,600	22,600	14.0	12.2	1,000	7518359
	CA*F3743*6D*	A*VC960804CNA*	28,800	22,600	15.0	12.5	1,000	7518397
	CA*F3743*6D*	A*VM970804CNA*	28,600	22,600	15.0	12.5	1,000	7518398
	CA*F3743*6D*	G*VC960804CNA*	28,800	22,600	15.0	12.5	1,000	7518399
	CA*F3743*6D*	G*VM970804CNA*	28,600	22,600	15.0	12.5	1,000	7518400
	CA*F3743*6D*+TXV	A*EC960302BNA*	28,400	22,400	15.0	12.5	940	7518366
	CA*F3743*6D*+TXV	A*EC960402BNA*	28,400	22,400	15.0	12.5	925	7518367
	CA*F3743*6D*+TXV	A*EC960603BNA*	28,400	22,400	15.0	12.5	965	7518368
	CA*F3743*6D*+TXV	A*EC960803BNA*	28,400	22,400	15.0	12.5	950	7518369
	CA*F3743*6D*+TXV	A*EC961004CNA*	28,800	22,600	15.0	12.5	1,025	7518370
	CA*F3743*6D*+TXV	A*VC80604B*B*	28,600	22,600	15.0	12.5	1,000	7518371
	CA*F3743*6D*+TXV	A*VC80805C*B*	28,600	22,600	15.0	12.5	990	7518372
	CA*F3743*6D*+TXV	A*VC81005C*B*	28,600	22,600	15.0	12.5	1,000	7518373
	CA*F3743*6D*+TXV	A*VC960403BNA*	28,800	22,600	15.0	12.5	1,000	7518374
	CA*F3743*6D*+TXV	A*VC960603BNA*	28,600	22,600	15.0	12.5	1,040	7518375
	CA*F3743*6D*+TXV	A*VC960803BNA*	28,400	22,400	15.0	12.5	975	7518376
	CA*F3743*6D*+TXV	A*VC960804CNA*	28,800	22,600	15.0	12.5	1,000	7518377
	CA*F3743*6D*+TXV	A*VM970603BNA*	28,400	22,400	15.0	12.5	1,040	7518378
	CA*F3743*6D*+TXV	A*VM970804CNA*	28,600	22,600	15.0	12.5	1,000	7518379
	CA*F3743*6D*+TXV	G*E80603B*B*	28,400	22,400	15.0	12.5	1,050	7518380
	CA*F3743*6D*+TXV	G*E80805C*B*	28,600	22,600	15.0	12.5	1,000	7518381
	CA*F3743*6D*+TXV	G*E81005C*B*	28,400	22,400	15.0	12.5	1,000	7518382
	CA*F3743*6D*+TXV	G*EC960302BNA*	28,400	22,400	15.0	12.5	940	7518383
	CA*F3743*6D*+TXV	G*EC960402BNA*	28,400	22,400	15.0	12.5	925	7518384
	CA*F3743*6D*+TXV	G*EC960603BNA*	28,400	22,400	15.0	12.5	965	7518385
	CA*F3743*6D*+TXV	G*EC960803BNA*	28,400	22,400	15.0	12.5	950	7518386
	CA*F3743*6D*+TXV	G*EC961004CNA*	28,800	22,600	15.0	12.5	1,025	7518387
	CA*F3743*6D*+TXV	G*VC80604B*B*	28,600	22,600	15.0	12.5	1,000	7518388
	CA*F3743*6D*+TXV	G*VC80805C*B*	28,600	22,600	15.0	12.5	990	7518389
	CA*F3743*6D*+TXV	G*VC81005C*B*	28,600	22,600	15.0	12.5	1,000	7518390
	CA*F3743*6D*+TXV	G*VC960403BNA*	28,800	22,600	15.0	12.5	1,000	7518391
	CA*F3743*6D*+TXV	G*VC960603BNA*	28,600	22,600	15.0	12.5	1,040	7518392
	CA*F3743*6D*+TXV	G*VC960803BNA*	28,400	22,400	15.0	12.5	975	7518393
	CA*F3743*6D*+TXV	G*VC960804CNA*	28,800	22,600	15.0	12.5	1,000	7518394
	CA*F3743*6D*+TXV	G*VM970603BNA*	28,400	22,400	15.0	12.5	1,040	7518395
	CA*F3743*6D*+TXV	G*VM970804CNA*	28,600	22,600	15.0	12.5	1,000	7518396
	CAPT3743*4A*	A*EC960302BNA*	28,200	22,200	14.5	12.2	940	7518404
	CAPT3743*4A*	A*EC960402BNA*	28,200	22,200	14.5	12.2	925	7518405
	CAPT3743*4A*	A*EC960803BNA*	28,200	22,200	14.5	12.2	950	7518407
	CAPT3743*4A*	A*EC961004CNA*	28,600	22,600	14.5	12.2	1,025	7518408
	CAPT3743*4A*	A*VC80604B*B*	28,400	22,400	14.5	12.2	1,000	7518409
	CAPT3743*4A*	A*VC81005C*B*	28,400	22,400	14.5	12.2	1,000	7518411
	CAPT3743*4A*	A*VC960403BNA*	28,400	22,400	14.5	12.2	1,000	7518412
CAPT3743*4A*	A*VC960603BNA*	28,400	22,400	14.5	12.2	1,040	7518413	
CAPT3743*4A*	A*VC960803BNA*	27,800	21,800	15.0	12.5	975	7518414	
CAPT3743*4A*	A*VC960804CNA*	28,400	22,400	14.5	12.2	1,000	7518415	
CAPT3743*4A*	A*VM970603BNA*	28,400	22,400	15.0	12.5	1,040	7518416	
CAPT3743*4A*	A*VM970804CNA*	28,400	22,400	14.5	12.2	1,000	7518417	

See Notes on Page 69.

OUTDOOR UNIT	INDOOR UNITS		COOLING RATINGS				CFM	AHRI #
	COILS/AIR HANDLERS	FURNACES	TOTAL ¹	SENS. ¹	SEER ²	EER ³		
VSX14 0311A* (cont.)	CAPT3743*4A*	G*E80603B*B*	28,400	22,400	14.5	12.2	1,050	7518418
	CAPT3743*4A*	G*E80805C*B*	28,400	22,400	14.5	12.2	1,000	7518419
	CAPT3743*4A*	G*EC960302BNA*	28,200	22,200	14.5	12.2	940	7518421
	CAPT3743*4A*	G*EC960402BNA*	28,200	22,200	14.5	12.2	925	7518422
	CAPT3743*4A*	G*EC960803BNA*	28,200	22,200	14.5	12.2	950	7518424
	CAPT3743*4A*	G*EC961004CNA*	28,600	22,600	14.5	12.2	1,025	7518425
	CAPT3743*4A*	G*VC80604B*B*	28,400	22,400	14.5	12.2	1,000	7518426
	CAPT3743*4A*	G*VC81005C*B*	28,400	22,400	14.5	12.2	1,000	7518428
	CAPT3743*4A*	G*VC960403BNA*	28,400	22,400	14.5	12.2	1,000	7518429
	CAPT3743*4A*	G*VC960603BNA*	28,400	22,400	14.5	12.2	1,040	7518430
	CAPT3743*4A*	G*VC960803BNA*	27,800	21,800	15.0	12.5	975	7518431
	CAPT3743*4A*	G*VC960804CNA*	28,400	22,400	14.5	12.2	1,000	7518432
	CAPT3743*4A*	G*VM970603BNA*	28,400	22,400	15.0	12.5	1,040	7518433
	CAPT3743*4A*	G*VM970804CNA*	28,400	22,400	14.5	12.2	1,000	7518434
	CAPT3743*4A*+EEP		28,000	22,000	14.5	12.2	1,000	7518401
	CAPT3743*4A*+MBVC1200**-1A*		28,600	22,600	15.0	12.5	1,000	7518402
	CAPT3743*4A*+MBVC1600**-1A*		28,600	22,600	15.0	12.5	1,000	7518403
	CHPF3636B6C*+TXV	A*VC960403BNA*	28,000	22,000	14.5	12.5	1,000	7518435
	CHPF3636B6C*+TXV	A*VC960603BNA*	28,000	22,000	14.5	12.2	1,040	7518436
	CHPF3636B6C*+TXV	A*VC960803BNA*	28,000	22,000	14.5	12.2	975	7518437
	CHPF3636B6C*+TXV	A*VM970603BNA*	28,000	22,000	14.5	12.2	1,040	7518438
	CHPF3636B6C*+TXV	G*VC960403BNA*	28,000	22,000	14.5	12.5	1,000	7518439
	CHPF3636B6C*+TXV	G*VC960603BNA*	28,000	22,000	14.5	12.2	1,040	7518440
	CHPF3636B6C*+TXV	G*VC960803BNA*	28,000	22,000	14.5	12.2	975	7518441
	CHPF3636B6C*+TXV	G*VM970603BNA*	28,000	22,000	14.5	12.2	1,040	7518442
	CHPF3642C6C*+EEP		28,600	22,600	14.0	12.2	1,000	7518443
	CHPF3642C6C*+EEP+TXV		28,000	22,000	14.5	12.2	1,000	7518444
	CHPF3642C6C*+MBVC1200**-1A*		28,000	22,000	14.5	12.2	1,000	7519542
	CHPF3642C6C*+MBVC1200**-1A*+TXV		28,000	22,000	14.5	12.2	1,000	7518445
	CHPF3642C6C*+MBVC1600**-1A*		28,000	22,000	14.5	12.2	1,000	7518446
	CHPF3642C6C*+MBVC1600**-1A*+TXV		28,400	22,400	15.0	12.5	1,000	7518447
	CHPF3642C6C*+TXV	A*EC960302BNA*	28,400	22,400	14.5	12.2	940	7518448
	CHPF3642C6C*+TXV	A*EC960402BNA*	28,400	22,400	15.0	12.5	925	7518449
	CHPF3642C6C*+TXV	A*EC960603BNA*	28,400	22,400	14.5	12.2	965	7518450
	CHPF3642C6C*+TXV	A*EC960803BNA*	28,400	22,400	14.5	12.2	950	7518451
	CHPF3642C6C*+TXV	A*VC80604B*B*	28,000	22,000	14.5	12.2	1,000	7518452
	CHPF3642C6C*+TXV	G*E80603B*B*	28,000	22,000	14.5	12.2	1,050	7518453
	CHPF3642C6C*+TXV	G*EC960302BNA*	28,400	22,400	14.5	12.2	940	7518454
	CHPF3642C6C*+TXV	G*EC960402BNA*	28,400	22,400	15.0	12.5	925	7518455
	CHPF3642C6C*+TXV	G*EC960603BNA*	28,400	22,400	14.5	12.2	965	7518456
	CHPF3642C6C*+TXV	G*EC960803BNA*	28,400	22,400	14.5	12.2	950	7518457
	CHPF3642C6C*+TXV	G*VC80604B*B*	28,000	22,000	14.5	12.2	1,000	7518458
	CHPF3642D6C*	A*VC960804CNA*	28,600	22,600	14.5	12.2	1,000	7518471
	CHPF3642D6C*	A*VM970804CNA*	28,600	22,600	14.5	12.2	1,000	7518472
	CHPF3642D6C*	G*VC960804CNA*	28,600	22,600	14.5	12.2	1,000	7518473
	CHPF3642D6C*	G*VM970804CNA*	28,600	22,600	14.5	12.2	1,000	7518474
	CHPF3642D6C*+TXV	A*EC961004CNA*	28,800	22,600	15.0	12.5	1,025	7518459
	CHPF3642D6C*+TXV	A*VC80805C*B*	28,600	22,600	15.0	12.5	990	7518460
	CHPF3642D6C*+TXV	A*VC81005C*B*	28,600	22,600	14.5	12.2	1,000	7518461
	CHPF3642D6C*+TXV	A*VC960804CNA*	28,600	22,600	14.5	12.2	1,000	7518462
CHPF3642D6C*+TXV	A*VM970804CNA*	28,600	22,600	14.5	12.2	1,000	7518463	
CHPF3642D6C*+TXV	G*E80805C*B*	28,000	22,000	15.0	12.5	1,000	7518464	
CHPF3642D6C*+TXV	G*E81005C*B*	28,600	22,600	15.0	12.5	1,000	7518465	
CHPF3642D6C*+TXV	G*EC961004CNA*	28,800	22,600	15.0	12.5	1,025	7518466	
CHPF3642D6C*+TXV	G*VC80805C*B*	28,600	22,600	15.0	12.5	990	7518467	

See Notes on Page 69.

OUTDOOR UNIT	INDOOR UNITS		COOLING RATINGS				CFM	AHRI #
	COILS/AIR HANDLERS	FURNACES	TOTAL ¹	SENS. ¹	SEER ²	EER ³		
VSX14 0311A* (cont.)	CHPF3642D6C*+TXV	G*VC81005C*B*	28,600	22,600	14.5	12.2	1,000	7518468
	CHPF3642D6C*+TXV	G*VC960804CNA*	28,600	22,600	14.5	12.2	1,000	7518469
	CHPF3642D6C*+TXV	G*VM970804CNA*	28,600	22,600	14.5	12.2	1,000	7518470
	CSCF3642N6D*	A*VC960804CNA*	28,800	22,600	15.0	12.5	1,000	7518508
	CSCF3642N6D*	A*VM970804CNA*	28,600	22,600	15.0	12.5	1,000	7518509
	CSCF3642N6D*	G*VC960804CNA*	28,800	22,600	15.0	12.5	1,000	7518510
	CSCF3642N6D*	G*VM970804CNA*	28,600	22,600	15.0	12.5	1,000	7518511
	CSCF3642N6D*+EEP		28,400	22,400	14.0	12.2	1,000	7518475
	CSCF3642N6D*+EEP+TXV		28,400	22,400	14.5	12.2	1,000	7518476
	CSCF3642N6D*+TXV	A*EC960302BNA*	28,400	22,400	14.5	12.2	940	7518477
	CSCF3642N6D*+TXV	A*EC960402BNA*	28,400	22,400	14.5	12.2	925	7518478
	CSCF3642N6D*+TXV	A*EC960603BNA*	28,400	22,400	14.5	12.2	965	7518479
	CSCF3642N6D*+TXV	A*EC960803BNA*	28,400	22,400	14.5	12.2	950	7518480
	CSCF3642N6D*+TXV	A*EC961004CNA*	28,400	22,400	14.5	12.2	1,025	7518481
	CSCF3642N6D*+TXV	A*VC80604B*B*	28,600	22,600	15.0	12.5	1,000	7518482
	CSCF3642N6D*+TXV	A*VC80805C*B*	28,400	22,400	15.0	12.5	990	7518483
	CSCF3642N6D*+TXV	A*VC81005C*B*	28,600	22,600	15.0	12.5	1,000	7518484
	CSCF3642N6D*+TXV	A*VC960403BNA*	28,600	22,600	15.0	12.5	1,000	7518485
	CSCF3642N6D*+TXV	A*VC960603BNA*	28,400	22,400	15.0	12.5	1,040	7518486
	CSCF3642N6D*+TXV	A*VC960803BNA*	28,400	22,400	15.0	12.5	975	7518487
	CSCF3642N6D*+TXV	A*VC960804CNA*	28,800	22,600	15.0	12.5	1,000	7518488
	CSCF3642N6D*+TXV	A*VM970603BNA*	28,400	22,400	15.0	12.5	1,040	7518489
	CSCF3642N6D*+TXV	A*VM970804CNA*	28,600	22,600	15.0	12.5	1,000	7518490
	CSCF3642N6D*+TXV	G*E80603B*B*	28,600	22,600	15.0	12.5	1,050	7518491
	CSCF3642N6D*+TXV	G*E80805C*B*	28,400	22,400	15.0	12.5	1,000	7518492
	CSCF3642N6D*+TXV	G*E81005C*B*	28,400	22,400	15.0	12.5	1,000	7518493
	CSCF3642N6D*+TXV	G*EC960302BNA*	28,400	22,400	14.5	12.2	940	7518494
	CSCF3642N6D*+TXV	G*EC960402BNA*	28,400	22,400	14.5	12.2	925	7518495
	CSCF3642N6D*+TXV	G*EC960603BNA*	28,400	22,400	14.5	12.2	965	7518496
	CSCF3642N6D*+TXV	G*EC960803BNA*	28,400	22,400	14.5	12.2	950	7518497
	CSCF3642N6D*+TXV	G*EC961004CNA*	28,400	22,400	14.5	12.2	1,025	7518498
	CSCF3642N6D*+TXV	G*VC80604B*B*	28,600	22,600	15.0	12.5	1,000	7518499
	CSCF3642N6D*+TXV	G*VC80805C*B*	28,400	22,400	15.0	12.5	990	7518500
	CSCF3642N6D*+TXV	G*VC81005C*B*	28,600	22,600	15.0	12.5	1,000	7518501
	CSCF3642N6D*+TXV	G*VC960403BNA*	28,600	22,600	15.0	12.5	1,000	7518502
	CSCF3642N6D*+TXV	G*VC960603BNA*	28,400	22,400	15.0	12.5	1,040	7518503
	CSCF3642N6D*+TXV	G*VC960803BNA*	28,400	22,400	15.0	12.5	975	7518504
	CSCF3642N6D*+TXV	G*VC960804CNA*	28,800	22,600	15.0	12.5	1,000	7518505
	CSCF3642N6D*+TXV	G*VM970603BNA*	28,400	22,400	15.0	12.5	1,040	7518506
	CSCF3642N6D*+TXV	G*VM970804CNA*	28,600	22,600	15.0	12.5	1,000	7518507
VSX14 0361A*	ARUF37C14A*		33,600	25,000	14.0	11.5	1,050	7984210
	ARUF37D14A*		33,600	25,000	14.0	11.5	1,240	8171727
	ASPT36C14A*		34,200	25,400	14.5	11.5	1,210	7518512
	ASPT42D14A*		34,800	25,800	14.5	12.0	1,280	7518513
	AVPTC36C14A*		34,200	25,400	14.5	11.5	1,100	7518514
	AVPTC42D14A*		34,800	25,800	14.5	12.0	1,120	7518515
	AWUF37XX16B*+TXV		33,000	24,400	14.5	11.5	1,050	7518516
	CA*F3137*6A*+EEP		34,000	25,200	14.0	11.5	1,200	8187523
	CA*F3137*6A*+EEP+TXV		34,000	25,200	14.0	11.5	1,200	8187524
	CA*F3137*6A*+TXV	G*E80603B*B*	33,400	24,800	14.0	11.5	1,100	8187525
	CA*F3137*6A*+TXV	G*VC80604B*B*	33,600	25,000	14.0	11.5	1,240	8187526
	CA*F3137*6A*+TXV	G*VC960403BNA*	34,200	25,400	14.0	11.5	1,200	8187527
	CA*F3137*6A*+TXV	G*VC960603BNA*	34,400	25,400	14.0	11.5	1,200	8187528
	CA*F3137*6A*+TXV	G*VC960803BNA*	34,400	25,400	14.0	11.5	1,150	8187529
	CA*F3137*6A*+TXV	G*VM970603BNA*	34,400	25,400	14.0	11.5	1,200	8187530

See Notes on Page 69.

OUTDOOR UNIT	INDOOR UNITS		COOLING RATINGS				CFM	AHRI #
	COILS/AIR HANDLERS	FURNACES	TOTAL ¹	SENS. ¹	SEER ²	EER ³		
VSX14 0361A* (cont.)	CA*F3137*6A*+TXV	G*VM970803BNA*	34,400	25,400	14.0	11.5	1,150	8187531
	CA*F3137*6A*+TXV	G*EC960603BNA*	34,200	25,400	14.0	11.5	1,100	8187532
	CA*F3137*6A*+TXV	G*EC960803BNA*	34,200	25,400	14.0	11.5	1,100	8187533
	CA*F3137*6A*+TXV	A*EH800603B*A*	33,400	24,800	14.0	11.5	1,100	8187544
	CA*F3137*6A*+TXV	A*VC80604B*B*	33,600	25,000	14.0	11.5	1,240	8187545
	CA*F3137*6A*+TXV	A*VC960403BNA*	34,200	25,400	14.0	11.5	1,200	8187546
	CA*F3137*6A*+TXV	A*VC960603BNA*	34,400	25,400	14.0	11.5	1,200	8187547
	CA*F3137*6A*+TXV	A*VC960803BNA*	34,400	25,400	14.0	11.5	1,150	8187548
	CA*F3137*6A*+TXV	A*VM970603BNA*	34,400	25,400	14.0	11.5	1,200	8187549
	CA*F3137*6A*+TXV	A*VM970803BNA*	34,400	25,400	14.0	11.5	1,150	8187550
	CA*F3137*6A*+TXV	A*EC960603BNA*	34,200	25,400	14.0	11.5	1,100	8187551
	CA*F3137*6A*+TXV	A*EC960803BNA*	34,200	25,400	14.0	11.5	1,100	8187552
	CA*F3642*6D*+EEP		34,000	25,200	14.0	11.5	1,200	7518517
	CA*F3642*6D*+EEP+TXV		34,000	25,200	14.0	11.5	1,200	7518518
	CA*F3642*6D*+MBVC1600**-1A*		34,000	25,200	14.5	11.5	1,200	7518519
	CA*F3642*6D*+MBVC2000**-1A*		34,000	25,200	14.5	12.0	1,200	7518520
	CA*F3743*6D*	A*EC961004CNA*	34,600	25,600	14.5	11.5	1,250	7518564
	CA*F3743*6D*	A*EC961205DNA*	34,000	25,200	14.5	11.5	1,075	7518565
	CA*F3743*6D*	A*VC80805C*B*	33,600	25,000	14.5	11.5	1,200	7518566
	CA*F3743*6D*	A*VC81005C*B*	33,400	24,800	14.5	11.5	1,200	7518567
	CA*F3743*6D*	A*VC960804CNA*	34,600	25,600	14.5	11.5	1,190	7518568
	CA*F3743*6D*	A*VC961005CNA*	34,600	25,600	14.5	11.5	1,175	7518569
	CA*F3743*6D*	A*VC961205DNA*	34,600	25,600	14.5	11.5	1,200	7518570
	CA*F3743*6D*	A*VM970804CNA*	34,600	25,600	14.5	11.5	1,190	7518571
	CA*F3743*6D*	A*VM971005CNA*	34,600	25,600	14.5	11.5	1,175	7518572
	CA*F3743*6D*	A*VM971205DNA*	34,600	25,600	14.5	11.5	1,200	7518573
	CA*F3743*6D*	G*E80805C*B*	33,600	25,000	14.5	11.5	1,210	7518574
	CA*F3743*6D*	G*E81005C*B*	34,000	25,200	14.5	11.5	1,230	7518575
	CA*F3743*6D*	G*EC961004CNA*	34,600	25,600	14.5	11.5	1,250	7518576
	CA*F3743*6D*	G*EC961205DNA*	34,000	25,200	14.5	11.5	1,075	7518577
	CA*F3743*6D*	G*VC80805C*B*	33,600	25,000	14.5	11.5	1,200	7518578
	CA*F3743*6D*	G*VC81005C*B*	33,400	24,800	14.5	11.5	1,200	7518579
	CA*F3743*6D*	G*VC960804CNA*	34,600	25,600	14.5	11.5	1,190	7518580
	CA*F3743*6D*	G*VC961005CNA*	34,600	25,600	14.5	11.5	1,175	7518581
	CA*F3743*6D*	G*VC961205DNA*	34,600	25,600	14.5	11.5	1,200	7518582
	CA*F3743*6D*	G*VM970804CNA*	34,600	25,600	14.5	11.5	1,190	7518583
	CA*F3743*6D*	G*VM971005CNA*	34,600	25,600	14.5	11.5	1,175	7518584
	CA*F3743*6D*	G*VM971205DNA*	34,600	25,600	14.5	11.5	1,200	7518585
	CA*F3743*6D*+EEP		34,600	25,600	14.0	11.5	1,200	7518521
	CA*F3743*6D*+EEP+TXV		34,600	25,600	14.5	11.5	1,200	7518522
	CA*F3743*6D*+MBVC1600**-1A*		35,000	26,000	14.5	11.5	1,200	7518523
	CA*F3743*6D*+MBVC2000**-1A*		35,000	26,000	14.5	11.5	1,200	7518524
	CA*F3743*6D*+TXV	A*EC960603BNA*	34,200	25,400	14.5	11.5	1,150	7518525
	CA*F3743*6D*+TXV	A*EC960803BNA*	34,200	25,400	14.5	11.5	1,150	7518526
	CA*F3743*6D*+TXV	A*EC961004CNA*	34,600	25,600	14.5	11.5	1,250	7518527
	CA*F3743*6D*+TXV	A*EC961205DNA*	34,000	25,200	14.5	12.0	1,075	7518528
	CA*F3743*6D*+TXV	A*VC80604B*B*	33,600	25,000	14.5	11.5	1,220	7518529
	CA*F3743*6D*+TXV	A*VC80805C*B*	33,600	25,000	14.5	12.0	1,200	7518530
	CA*F3743*6D*+TXV	A*VC81005C*B*	33,400	24,800	14.5	12.0	1,200	7518531
	CA*F3743*6D*+TXV	A*VC960403BNA*	34,200	25,400	14.5	11.5	1,200	7518532
	CA*F3743*6D*+TXV	A*VC960603BNA*	34,400	25,400	14.5	11.5	1,250	7518533
	CA*F3743*6D*+TXV	A*VC960803BNA*	34,400	25,400	14.5	11.5	1,250	7518534
CA*F3743*6D*+TXV	A*VC960804CNA*	34,600	25,600	14.5	12.0	1,190	7518535	
CA*F3743*6D*+TXV	A*VC961005CNA*	34,600	25,600	14.5	12.0	1,175	7518536	
CA*F3743*6D*+TXV	A*VC961205DNA*	34,600	25,600	14.5	12.0	1,200	7518537	

See Notes on Page 69.

OUTDOOR UNIT	INDOOR UNITS		COOLING RATINGS				CFM	AHRI #
	COILS/AIR HANDLERS	FURNACES	TOTAL ¹	SENS. ¹	SEER ²	EER ³		
VSX14 0361A* (cont.)	CA*F3743*6D*+TXV	A*VM970603BNA*	34,400	25,400	14.5	11.5	1,250	7518538
	CA*F3743*6D*+TXV	A*VM970803BNA*	34,400	25,400	14.5	11.5	1,250	7518539
	CA*F3743*6D*+TXV	A*VM970804CNA*	34,600	25,600	14.5	11.5	1,190	7518540
	CA*F3743*6D*+TXV	A*VM971005CNA*	34,600	25,600	14.5	11.5	1,175	7518541
	CA*F3743*6D*+TXV	A*VM971205DNA*	34,600	25,600	14.5	12.0	1,200	7518542
	CA*F3743*6D*+TXV	G*E80603B*B*	33,400	24,800	14.5	11.5	1,250	7518543
	CA*F3743*6D*+TXV	G*E80805C*B*	33,600	25,000	14.5	11.5	1,210	7518544
	CA*F3743*6D*+TXV	G*E81005C*B*	34,000	25,200	14.5	11.5	1,230	7518545
	CA*F3743*6D*+TXV	G*EC960603BNA*	34,200	25,400	14.5	11.5	1,150	7518546
	CA*F3743*6D*+TXV	G*EC960803BNA*	34,200	25,400	14.5	11.5	1,150	7518547
	CA*F3743*6D*+TXV	G*EC961004CNA*	34,600	25,600	14.5	11.5	1,250	7518548
	CA*F3743*6D*+TXV	G*EC961205DNA*	34,000	25,200	14.5	12.0	1,075	7518549
	CA*F3743*6D*+TXV	G*VC80604B*B*	33,600	25,000	14.5	11.5	1,220	7518550
	CA*F3743*6D*+TXV	G*VC80805C*B*	33,600	25,000	14.5	12.0	1,200	7518551
	CA*F3743*6D*+TXV	G*VC81005C*B*	33,400	24,800	14.5	12.0	1,200	7518552
	CA*F3743*6D*+TXV	G*VC960403BNA*	34,200	25,400	14.5	11.5	1,200	7518553
	CA*F3743*6D*+TXV	G*VC960603BNA*	34,400	25,400	14.5	11.5	1,250	7518554
	CA*F3743*6D*+TXV	G*VC960803BNA*	34,400	25,400	14.5	11.5	1,250	7518555
	CA*F3743*6D*+TXV	G*VC960804CNA*	34,600	25,600	14.5	12.0	1,190	7518556
	CA*F3743*6D*+TXV	G*VC961005CNA*	34,600	25,600	14.5	12.0	1,175	7518557
	CA*F3743*6D*+TXV	G*VC961205DNA*	34,600	25,600	14.5	12.0	1,200	7518558
	CA*F3743*6D*+TXV	G*VM970603BNA*	34,400	25,400	14.5	11.5	1,250	7518559
	CA*F3743*6D*+TXV	G*VM970803BNA*	34,400	25,400	14.5	11.5	1,250	7518560
	CA*F3743*6D*+TXV	G*VM970804CNA*	34,600	25,600	14.5	11.5	1,190	7518561
	CA*F3743*6D*+TXV	G*VM971005CNA*	34,600	25,600	14.5	11.5	1,175	7518562
	CA*F3743*6D*+TXV	G*VM971205DNA*	34,600	25,600	14.5	12.0	1,200	7518563
	CA*F4860*6D*+EEP		34,800	25,800	14.0	11.5	1,200	7518586
	CA*F4860*6D*+EEP+TXV		34,800	25,800	14.0	11.5	1,200	7518587
	CAPT3743*4A*	A*EC960803BNA*	34,200	25,400	14.0	11.5	1,150	7518589
	CAPT3743*4A*	A*VC80604B*B*	33,600	25,000	14.5	11.5	1,220	7518590
	CAPT3743*4A*	A*VC80805C*B*	33,600	25,000	14.5	11.5	1,200	7518591
	CAPT3743*4A*	A*VC81005C*B*	33,400	24,800	14.5	11.5	1,200	7518592
	CAPT3743*4A*	A*VC960403BNA*	34,000	25,200	14.5	11.5	1,200	7518593
	CAPT3743*4A*	A*VC960603BNA*	34,200	25,400	14.5	11.5	1,250	7518594
	CAPT3743*4A*	A*VC960803BNA*	34,200	25,400	14.5	11.5	1,250	7518595
	CAPT3743*4A*	A*VC960804CNA*	34,600	25,600	14.5	11.5	1,190	7518596
	CAPT3743*4A*	A*VC961005CNA*	34,600	25,600	14.5	11.5	1,175	7518597
	CAPT3743*4A*	A*VC961205DNA*	34,400	25,400	14.5	11.5	1,200	7518598
	CAPT3743*4A*	A*VM970603BNA*	34,200	25,400	14.5	11.5	1,250	7518599
	CAPT3743*4A*	A*VM970803BNA*	34,200	25,400	14.5	11.5	1,250	7518600
	CAPT3743*4A*	A*VM970804CNA*	34,600	25,600	14.5	11.5	1,190	7518601
	CAPT3743*4A*	A*VM971005CNA*	34,600	25,600	14.5	11.5	1,175	7518602
	CAPT3743*4A*	A*VM971205DNA*	34,400	25,400	14.5	11.5	1,200	7518603
	CAPT3743*4A*	G*E80805C*B*	33,600	25,000	14.5	11.5	1,210	7518604
	CAPT3743*4A*	G*E81005C*B*	34,000	25,200	14.5	11.5	1,230	7518605
	CAPT3743*4A*	G*EC960803BNA*	34,200	25,400	14.0	11.5	1,150	7518606
	CAPT3743*4A*	G*VC80604B*B*	33,600	25,000	14.5	11.5	1,220	7518607
	CAPT3743*4A*	G*VC80805C*B*	33,600	25,000	14.5	11.5	1,200	7518608
CAPT3743*4A*	G*VC81005C*B*	33,400	24,800	14.5	11.5	1,200	7518609	
CAPT3743*4A*	G*VC960403BNA*	34,000	25,200	14.5	11.5	1,200	7518610	
CAPT3743*4A*	G*VC960603BNA*	34,200	25,400	14.5	11.5	1,250	7518611	
CAPT3743*4A*	G*VC960803BNA*	34,200	25,400	14.5	11.5	1,250	7518612	
CAPT3743*4A*	G*VC960804CNA*	34,600	25,600	14.5	11.5	1,190	7518613	
CAPT3743*4A*	G*VC961005CNA*	34,600	25,600	14.5	11.5	1,175	7518614	
CAPT3743*4A*	G*VC961205DNA*	34,400	25,400	14.5	11.5	1,200	7518615	

See Notes on Page 69.

OUTDOOR UNIT	INDOOR UNITS		COOLING RATINGS				CFM	AHRI #
	COILS/AIR HANDLERS	FURNACES	TOTAL ¹	SENS. ¹	SEER ²	EER ³		
VSX14 0361A* (cont.)	CAPT3743*4A*	G*VM970603BNA*	34,200	25,400	14.5	11.5	1,250	7518616
	CAPT3743*4A*	G*VM970803BNA*	34,200	25,400	14.5	11.5	1,250	7518617
	CAPT3743*4A*	G*VM970804CNA*	34,600	25,600	14.5	11.5	1,190	7518618
	CAPT3743*4A*	G*VM971005CNA*	34,600	25,600	14.5	11.5	1,175	7518619
	CAPT3743*4A*	G*VM971205DNA*	34,400	25,400	14.5	11.5	1,200	7518620
	CAPT3743*4A*	A*EC960603BNA*	34,200	25,400	14.0	11.5	1,150	7518623
	CAPT3743*4A*	A*EC961004CNA*	34,600	25,600	14.5	11.5	1,250	7518624
	CAPT3743*4A*	A*EC961205DNA*	34,000	25,200	14.5	11.5	1,075	7518625
	CAPT3743*4A*	G*EC960603BNA*	34,200	25,400	14.0	11.5	1,150	7518626
	CAPT3743*4A*	G*EC961004CNA*	34,600	25,600	14.5	11.5	1,250	7518627
	CAPT3743*4A*	G*EC961205DNA*	34,000	25,200	14.5	11.5	1,075	7518628
	CAPT3743*4A*+EEP		34,600	25,600	14.5	11.5	1,200	7518588
	CAPT3743*4A*+MBVC1600** -1A*		34,000	25,200	14.5	11.5	1,205	7518621
	CAPT3743*4A*+MBVC2000** -1A*		34,000	25,200	14.5	11.5	1,205	7518622
	CHPF3642C6C*	G*E80805C*B*	33,600	25,000	14.5	11.5	1,210	7518637
	CHPF3642C6C*	G*E81005C*B*	34,000	25,200	14.5	11.5	1,230	7518638
	CHPF3642C6C*+EEP		34,600	25,600	14.0	11.5	1,200	7518629
	CHPF3642C6C*+EEP+TXV		34,600	25,600	14.0	11.5	1,200	7518630
	CHPF3642C6C*+MBVC1600** -1A*		35,000	26,000	14.5	11.5	1,200	7518639
	CHPF3642C6C*+TXV	A*EC960603BNA*	34,200	25,400	14.5	11.5	1,150	7518631
	CHPF3642C6C*+TXV	A*EC960803BNA*	34,200	25,400	14.5	11.5	1,150	7518632
	CHPF3642C6C*+TXV	G*E80805C*B*	33,600	25,000	14.5	11.5	1,210	7518633
	CHPF3642C6C*+TXV	G*E81005C*B*	34,000	25,200	14.5	12.0	1,230	7518634
	CHPF3642C6C*+TXV	G*EC960603BNA*	34,200	25,400	14.5	11.5	1,150	7518635
	CHPF3642C6C*+TXV	G*EC960803BNA*	34,200	25,400	14.5	11.5	1,150	7518636
	CHPF3642C6C*+TXV	G*E80603B*B*	33,400	24,800	14.5	11.5	1,250	7518640
	CHPF3743C6B*	A*VC80805C*B*	33,600	25,000	14.5	11.5	1,200	7518667
	CHPF3743C6B*	A*VC81005C*B*	33,400	24,800	14.5	11.5	1,200	7518668
	CHPF3743C6B*	A*VC960804CNA*	34,600	25,600	14.5	11.5	1,190	7518669
	CHPF3743C6B*	A*VC961005CNA*	34,600	25,600	14.5	11.5	1,175	7518670
	CHPF3743C6B*	A*VM970804CNA*	34,600	25,600	14.5	11.5	1,190	7518671
	CHPF3743C6B*	G*VC80805C*B*	33,600	25,000	14.5	11.5	1,200	7518672
	CHPF3743C6B*	G*VC81005C*B*	33,400	24,800	14.5	11.5	1,200	7518673
	CHPF3743C6B*	G*VC960804CNA*	34,600	25,600	14.5	11.5	1,190	7518674
	CHPF3743C6B*	G*VC961005CNA*	34,600	25,600	14.5	11.5	1,175	7518675
	CHPF3743C6B*	G*VM970804CNA*	34,600	25,600	14.5	11.5	1,190	7518676
	CHPF3743C6B*	A*EC961004CNA*	34,600	25,600	14.5	11.5	1,250	7518680
	CHPF3743C6B*	G*EC961004CNA*	34,600	25,600	14.5	11.5	1,250	7518681
	CHPF3743C6B*	A*VM971005CNA*	34,600	25,600	14.5	11.5	1,175	7520386
	CHPF3743C6B*	G*VM971005CNA*	34,600	25,600	14.5	11.5	1,175	7520387
	CHPF3743C6B*+EEP		34,000	25,200	14.0	11.5	1,150	7518641
	CHPF3743C6B*+EEP+TXV		34,000	25,200	14.5	11.5	1,150	7518642
	CHPF3743C6B*+MBVC1600** -1A*		35,000	26,000	14.5	11.5	1,200	7518677
	CHPF3743C6B*+TXV	A*VC80604B*B*	33,600	25,000	14.5	11.5	1,220	7518643
	CHPF3743C6B*+TXV	A*VC80805C*B*	33,600	25,000	14.5	12.0	1,200	7518644
	CHPF3743C6B*+TXV	A*VC81005C*B*	33,400	24,800	14.5	12.0	1,200	7518645
	CHPF3743C6B*+TXV	A*VC960403BNA*	34,200	25,400	14.5	11.5	1,200	7518646
	CHPF3743C6B*+TXV	A*VC960603BNA*	34,400	25,400	14.5	11.5	1,250	7518647
	CHPF3743C6B*+TXV	A*VC960803BNA*	34,400	25,400	14.5	11.5	1,250	7518648
	CHPF3743C6B*+TXV	A*VC960804CNA*	34,600	25,600	14.5	12.0	1,190	7518649
	CHPF3743C6B*+TXV	A*VC961005CNA*	34,600	25,600	14.5	12.0	1,175	7518650
	CHPF3743C6B*+TXV	A*VM970603BNA*	34,400	25,400	14.5	11.5	1,250	7518651
CHPF3743C6B*+TXV	A*VM970803BNA*	34,400	25,400	14.5	11.5	1,250	7518652	
CHPF3743C6B*+TXV	A*VM970804CNA*	34,600	25,600	14.5	11.5	1,190	7518653	
CHPF3743C6B*+TXV	A*VM971005CNA*	34,600	25,600	14.5	11.5	1,175	7518654	

See Notes on Page 69.

OUTDOOR UNIT	INDOOR UNITS		COOLING RATINGS				CFM	AHRI #
	COILS/AIR HANDLERS	FURNACES	TOTAL ¹	SENS. ¹	SEER ²	EER ³		
VSX14 0361A* (cont.)	CHPF3743C6B*+TXV	G*VC80604B*B*	33,600	25,000	14.5	11.5	1,220	7518655
	CHPF3743C6B*+TXV	G*VC80805C*B*	33,600	25,000	14.5	12.0	1,200	7518656
	CHPF3743C6B*+TXV	G*VC81005C*B*	33,400	24,800	14.5	12.0	1,200	7518657
	CHPF3743C6B*+TXV	G*VC960403BNA*	34,200	25,400	14.5	11.5	1,200	7518658
	CHPF3743C6B*+TXV	G*VC960603BNA*	34,400	25,400	14.5	11.5	1,250	7518659
	CHPF3743C6B*+TXV	G*VC960803BNA*	34,400	25,400	14.5	11.5	1,250	7518660
	CHPF3743C6B*+TXV	G*VC960804CNA*	34,600	25,600	14.5	12.0	1,190	7518661
	CHPF3743C6B*+TXV	G*VC961005CNA*	34,600	25,600	14.5	12.0	1,175	7518662
	CHPF3743C6B*+TXV	G*VM970603BNA*	34,400	25,400	14.5	11.5	1,250	7518663
	CHPF3743C6B*+TXV	G*VM970803BNA*	34,400	25,400	14.5	11.5	1,250	7518664
	CHPF3743C6B*+TXV	G*VM970804CNA*	34,600	25,600	14.5	11.5	1,190	7518665
	CHPF3743C6B*+TXV	G*VM971005CNA*	34,600	25,600	14.5	11.5	1,175	7518666
	CHPF3743C6B*+TXV	A*EC961004CNA*	34,600	25,600	14.5	11.5	1,250	7518678
	CHPF3743C6B*+TXV	G*EC961004CNA*	34,600	25,600	14.5	11.5	1,250	7518679
	CHPF3743D6B*	A*VC961205DNA*	34,600	25,600	14.5	11.5	1,200	7518690
	CHPF3743D6B*	A*VM971205DNA*	34,600	25,600	14.5	11.5	1,200	7518691
	CHPF3743D6B*	G*VC961205DNA*	34,600	25,600	14.5	11.5	1,200	7518692
	CHPF3743D6B*	G*VM971205DNA*	34,600	25,600	14.5	11.5	1,200	7518693
	CHPF3743D6B*	A*EC961205DNA*	34,000	25,200	14.5	11.5	1,075	7518694
	CHPF3743D6B*	G*EC961205DNA*	34,000	25,200	14.5	11.5	1,075	7518695
	CHPF3743D6B*+EEP		34,600	25,600	14.5	11.5	1,150	7518682
	CHPF3743D6B*+EEP+TXV		34,600	25,600	14.5	12.0	1,150	7518683
	CHPF3743D6B*+TXV	A*EC961205DNA*	34,000	25,200	14.5	12.0	1,075	7518684
	CHPF3743D6B*+TXV	A*VC961205DNA*	34,600	25,600	14.5	12.0	1,200	7518685
	CHPF3743D6B*+TXV	A*VM971205DNA*	34,600	25,600	14.5	12.0	1,200	7518686
	CHPF3743D6B*+TXV	G*EC961205DNA*	34,000	25,200	14.5	12.0	1,075	7518687
	CHPF3743D6B*+TXV	G*VC961205DNA*	34,600	25,600	14.5	12.0	1,200	7518688
	CHPF3743D6B*+TXV	G*VM971205DNA*	34,600	25,600	14.5	12.0	1,200	7518689
	CSCF4860N6D*	A*VC80805C*B*	33,600	25,000	14.5	11.5	1,200	7518728
	CSCF4860N6D*	A*VC81005C*B*	33,400	24,800	14.5	11.5	1,200	7518729
	CSCF4860N6D*	A*VC960804CNA*	34,600	25,600	14.5	11.5	1,190	7518730
	CSCF4860N6D*	A*VC961005CNA*	34,600	25,600	14.5	11.5	1,175	7518731
	CSCF4860N6D*	A*VC961205DNA*	34,600	25,600	14.5	11.5	1,200	7518732
	CSCF4860N6D*	A*VM970804CNA*	34,600	25,600	14.5	11.5	1,190	7518733
	CSCF4860N6D*	A*VM971005CNA*	34,600	25,600	14.5	11.5	1,175	7518734
	CSCF4860N6D*	A*VM971205DNA*	34,600	25,600	14.5	11.5	1,200	7518735
	CSCF4860N6D*	G*E80805C*B*	33,600	25,000	14.5	11.5	1,210	7518736
	CSCF4860N6D*	G*E81005C*B*	34,000	25,200	14.5	11.5	1,230	7518737
	CSCF4860N6D*	G*VC80805C*B*	33,600	25,000	14.5	11.5	1,200	7518738
	CSCF4860N6D*	G*VC81005C*B*	33,400	24,800	14.5	11.5	1,200	7518739
	CSCF4860N6D*	G*VC960804CNA*	34,600	25,600	14.5	11.5	1,190	7518740
	CSCF4860N6D*	G*VC961005CNA*	34,600	25,600	14.5	11.5	1,175	7518741
	CSCF4860N6D*	G*VC961205DNA*	34,600	25,600	14.5	11.5	1,200	7518742
	CSCF4860N6D*	G*VM970804CNA*	34,600	25,600	14.5	11.5	1,190	7518743
	CSCF4860N6D*	G*VM971005CNA*	34,600	25,600	14.5	11.5	1,175	7518744
	CSCF4860N6D*	G*VM971205DNA*	34,600	25,600	14.5	11.5	1,200	7518745
	CSCF4860N6D*+EEP		34,600	25,600	14.0	11.5	1,200	7518696
	CSCF4860N6D*+EEP+TXV		34,600	25,600	14.0	11.5	1,200	7518697
	CSCF4860N6D*+TXV	A*VC80604B*B*	33,600	25,000	14.5	11.5	1,220	7518698
	CSCF4860N6D*+TXV	A*VC80805C*B*	33,600	25,000	14.5	12.0	1,200	7518699
CSCF4860N6D*+TXV	A*VC81005C*B*	33,400	24,800	14.5	11.5	1,200	7518700	
CSCF4860N6D*+TXV	A*VC960403BNA*	34,200	25,400	14.5	11.5	1,200	7518701	
CSCF4860N6D*+TXV	A*VC960603BNA*	34,400	25,400	14.5	11.5	1,250	7518702	
CSCF4860N6D*+TXV	A*VC960803BNA*	34,400	25,400	14.5	11.5	1,250	7518703	
CSCF4860N6D*+TXV	A*VC960804CNA*	34,600	25,600	14.5	12.0	1,190	7518704	

See Notes on Page 69.

OUTDOOR UNIT	INDOOR UNITS		COOLING RATINGS				CFM	AHRI #
	COILS/AIR HANDLERS	FURNACES	TOTAL ¹	SENS. ¹	SEER ²	EER ³		
VSX14 0361A* (cont.)	CSCF4860N6D*+TXV	A*VC961005CNA*	34,600	25,600	14.5	11.5	1,175	7518705
	CSCF4860N6D*+TXV	A*VC961205DNA*	34,600	25,600	14.5	12.0	1,200	7518706
	CSCF4860N6D*+TXV	A*VM970603BNA*	34,400	25,400	14.5	11.5	1,250	7518707
	CSCF4860N6D*+TXV	A*VM970803BNA*	34,400	25,400	14.5	11.5	1,250	7518708
	CSCF4860N6D*+TXV	A*VM970804CNA*	34,600	25,600	14.5	11.5	1,190	7518709
	CSCF4860N6D*+TXV	A*VM971005CNA*	34,600	25,600	14.5	11.5	1,175	7518710
	CSCF4860N6D*+TXV	A*VM971205DNA*	34,600	25,600	14.5	12.0	1,200	7518711
	CSCF4860N6D*+TXV	G*E80805C*B*	33,600	25,000	14.5	11.5	1,210	7518712
	CSCF4860N6D*+TXV	G*E81005C*B*	34,000	25,200	14.5	12.0	1,230	7518713
	CSCF4860N6D*+TXV	G*VC80604B*B*	33,600	25,000	14.5	11.5	1,220	7518714
	CSCF4860N6D*+TXV	G*VC80805C*B*	33,600	25,000	14.5	12.0	1,200	7518715
	CSCF4860N6D*+TXV	G*VC81005C*B*	33,400	24,800	14.5	11.5	1,200	7518716
	CSCF4860N6D*+TXV	G*VC960403BNA*	34,200	25,400	14.5	11.5	1,200	7518717
	CSCF4860N6D*+TXV	G*VC960603BNA*	34,400	25,400	14.5	11.5	1,250	7518718
	CSCF4860N6D*+TXV	G*VC960803BNA*	34,400	25,400	14.5	11.5	1,250	7518719
	CSCF4860N6D*+TXV	G*VC960804CNA*	34,600	25,600	14.5	12.0	1,190	7518720
	CSCF4860N6D*+TXV	G*VC961005CNA*	34,600	25,600	14.5	11.5	1,175	7518721
	CSCF4860N6D*+TXV	G*VC961205DNA*	34,600	25,600	14.5	12.0	1,200	7518722
	CSCF4860N6D*+TXV	G*VM970603BNA*	34,400	25,400	14.5	11.5	1,250	7518723
	CSCF4860N6D*+TXV	G*VM970803BNA*	34,400	25,400	14.5	11.5	1,250	7518724
	CSCF4860N6D*+TXV	G*VM970804CNA*	34,600	25,600	14.5	11.5	1,190	7518725
	CSCF4860N6D*+TXV	G*VM971005CNA*	34,600	25,600	14.5	11.5	1,175	7518726
	CSCF4860N6D*+TXV	G*VM971205DNA*	34,600	25,600	14.5	12.0	1,200	7518727
CSCF4860N6D*+TXV	G*E80603B*B*	33,400	24,800	14.5	11.5	1,250	7518746	
VSX14 0371A*	ARUF37C14A*+TXV		33,400	25,200	14.0	12.2	1,050	7984211
	ARUF37D14A*		34,200	25,800	14.0	12.2	1,240	8171728
	ARUF49C14A*		34,000	25,800	14.0	12.2	1,220	7984212
	ASPT36C14A*		34,200	25,800	14.5	12.5	1,210	7518747
	ASPT42D14A*		34,200	25,800	15.0	12.5	1,280	7518748
	AVPTC36C14A*		34,000	25,800	14.5	12.2	1,100	7518749
	AVPTC42D14A*		34,800	26,400	15.0	12.5	1,120	7518750
	AWUF37XX16B*+TXV		33,000	25,000	14.5	12.2	355	7518751
	CA*F3137*6A*	A*VC80604B*B*	33,600	25,400	15.0	12.5	1,220	7520388
	CA*F3137*6A*	A*VC960403BNA*	34,000	25,800	15.0	12.5	1,200	7520389
	CA*F3137*6A*	A*VC960603BNA*	34,000	25,800	15.0	12.5	1,250	7520390
	CA*F3137*6A*	A*VC960803BNA*	34,000	25,800	15.0	12.5	1,250	7520391
	CA*F3137*6A*	A*VM970603BNA*	34,000	25,800	15.0	12.5	1,250	7520392
	CA*F3137*6A*	A*VM970803BNA*	34,000	25,800	15.0	12.5	1,250	7520393
	CA*F3137*6A*	G*E80603B*B*	33,400	25,200	14.5	12.2	1,225	7520394
	CA*F3137*6A*	G*VC80604B*B*	33,600	25,400	15.0	12.5	1,220	7520395
	CA*F3137*6A*	G*VC960403BNA*	34,000	25,800	15.0	12.5	1,200	7520396
	CA*F3137*6A*	G*VC960603BNA*	34,000	25,800	15.0	12.5	1,250	7520397
	CA*F3137*6A*	G*VC960803BNA*	34,000	25,800	15.0	12.5	1,250	7520398
	CA*F3137*6A*	G*VM970603BNA*	34,000	25,800	15.0	12.5	1,250	7520399
	CA*F3137*6A*	G*VM970803BNA*	34,000	25,800	15.0	12.5	1,250	7520400
	CA*F3137*6A*+EEP		34,000	25,800	14.0	12.2	1,200	7518774
	CA*F3137*6A*+EEP+TXV		34,000	25,800	14.0	12.2	1,200	7518775
	CA*F3743*6D*	A*EC961004CNA*	34,600	26,200	14.5	12.2	1,250	7518838
	CA*F3743*6D*	A*EC961205DNA*	34,400	26,000	15.0	12.5	1,075	7518839
	CA*F3743*6D*	A*VC80805C*B*	33,600	25,400	14.5	12.2	1,200	7518840
	CA*F3743*6D*	A*VC81005C*B*	33,400	25,200	14.5	12.2	1,200	7518841
	CA*F3743*6D*	A*VC960804CNA*	34,600	26,200	14.5	12.2	1,190	7518842
	CA*F3743*6D*	A*VC961005CNA*	34,600	26,200	14.5	12.2	1,175	7518843
	CA*F3743*6D*	A*VC961205DNA*	34,600	26,200	15.0	12.5	1,200	7518844
	CA*F3743*6D*	A*VM970804CNA*	34,600	26,200	14.5	12.2	1,190	7518845

See Notes on Page 69.

OUTDOOR UNIT	INDOOR UNITS		COOLING RATINGS				CFM	AHRI #
	COILS/AIR HANDLERS	FURNACES	TOTAL ¹	SENS. ¹	SEER ²	EER ³		
VSX14 0371A* (cont.)	CA*F3743*6D*	A*VM971005CNA*	34,600	26,200	14.5	12.2	1,175	7518846
	CA*F3743*6D*	A*VM971205DNA*	34,600	26,200	15.0	12.5	1,200	7518847
	CA*F3743*6D*	G*E80805C*B*	33,600	25,400	14.5	12.2	1,210	7518848
	CA*F3743*6D*	G*E81005C*B*	34,000	25,800	14.5	12.2	1,200	7518849
	CA*F3743*6D*	G*EC961004CNA*	34,600	26,200	14.5	12.2	1,250	7518850
	CA*F3743*6D*	G*EC961205DNA*	34,400	26,000	15.0	12.5	1,075	7518851
	CA*F3743*6D*	G*VC80805C*B*	33,600	25,400	14.5	12.2	1,200	7518852
	CA*F3743*6D*	G*VC81005C*B*	33,400	25,200	14.5	12.2	1,200	7518853
	CA*F3743*6D*	G*VC960804CNA*	34,600	26,200	14.5	12.2	1,190	7518854
	CA*F3743*6D*	G*VC961005CNA*	34,600	26,200	14.5	12.2	1,175	7518855
	CA*F3743*6D*	G*VC961205DNA*	34,600	26,200	15.0	12.5	1,200	7518856
	CA*F3743*6D*	G*VM970804CNA*	34,600	26,200	14.5	12.2	1,190	7518857
	CA*F3743*6D*	G*VM971005CNA*	34,600	26,200	14.5	12.2	1,175	7518858
	CA*F3743*6D*	G*VM971205DNA*	34,600	26,200	15.0	12.5	1,200	7518859
	CA*F3743*6D*+EEP		34,000	25,800	14.0	12.2	1,200	7518797
	CA*F3743*6D*+EEP+TXV		34,000	25,800	14.5	12.2	1,200	7518798
	CA*F3743*6D*+MBVC1600**-1A*		34,600	26,200	14.5	12.2	1,200	7518799
	CA*F3743*6D*+MBVC1600**-1A*+TXV		34,600	26,200	14.5	12.2	1,200	7518800
	CA*F3743*6D*+MBVC2000**-1A*		34,600	26,200	15.0	12.5	1,200	7518801
	CA*F3743*6D*+MBVC2000**-1A*+TXV		34,600	26,200	15.0	12.5	1,200	7518802
	CA*F3743*6D*+TXV	A*EC961004CNA*	34,600	26,200	15.0	12.5	1,250	7518803
	CA*F3743*6D*+TXV	A*EC961205DNA*	34,400	26,000	15.0	12.5	1,075	7518804
	CA*F3743*6D*+TXV	A*VC80604B*B*	33,600	25,400	14.5	12.2	1,220	7518805
	CA*F3743*6D*+TXV	A*VC80805C*B*	33,600	25,400	15.0	12.5	1,200	7518806
	CA*F3743*6D*+TXV	A*VC81005C*B*	33,400	25,200	15.0	12.5	1,200	7518807
	CA*F3743*6D*+TXV	A*VC960403BNA*	34,000	25,800	14.5	12.2	1,200	7518808
	CA*F3743*6D*+TXV	A*VC960603BNA*	34,400	26,000	14.5	12.2	1,250	7518809
	CA*F3743*6D*+TXV	A*VC960803BNA*	34,400	26,000	14.5	12.2	1,250	7518810
	CA*F3743*6D*+TXV	A*VC960804CNA*	34,600	26,200	15.0	12.5	1,190	7518811
	CA*F3743*6D*+TXV	A*VC961005CNA*	34,600	26,200	15.0	12.5	1,175	7518812
	CA*F3743*6D*+TXV	A*VC961205DNA*	34,600	26,200	15.0	12.5	1,200	7518813
	CA*F3743*6D*+TXV	A*VM970603BNA*	34,200	25,800	14.5	12.2	1,250	7518814
	CA*F3743*6D*+TXV	A*VM970803BNA*	34,400	26,000	14.5	12.2	1,250	7518815
	CA*F3743*6D*+TXV	A*VM970804CNA*	34,600	26,200	15.0	12.5	1,190	7518816
	CA*F3743*6D*+TXV	A*VM971005CNA*	34,600	26,200	15.0	12.5	1,175	7518817
	CA*F3743*6D*+TXV	A*VM971205DNA*	34,600	26,200	15.0	12.5	1,200	7518818
	CA*F3743*6D*+TXV	G*E80603B*B*	33,400	25,200	14.5	12.2	1,225	7518819
	CA*F3743*6D*+TXV	G*E80805C*B*	33,600	25,400	15.0	12.5	1,210	7518820
	CA*F3743*6D*+TXV	G*E81005C*B*	34,000	25,800	15.0	12.5	1,200	7518821
	CA*F3743*6D*+TXV	G*EC961004CNA*	34,600	26,200	15.0	12.5	1,250	7518822
	CA*F3743*6D*+TXV	G*EC961205DNA*	34,400	26,000	15.0	12.5	1,075	7518823
	CA*F3743*6D*+TXV	G*VC80604B*B*	33,600	25,400	14.5	12.2	1,220	7518824
	CA*F3743*6D*+TXV	G*VC80805C*B*	33,600	25,400	15.0	12.5	1,200	7518825
	CA*F3743*6D*+TXV	G*VC81005C*B*	33,400	25,200	15.0	12.5	1,200	7518826
	CA*F3743*6D*+TXV	G*VC960403BNA*	34,000	25,800	14.5	12.2	1,200	7518827
	CA*F3743*6D*+TXV	G*VC960603BNA*	34,400	26,000	14.5	12.2	1,250	7518828
	CA*F3743*6D*+TXV	G*VC960803BNA*	34,400	26,000	14.5	12.2	1,250	7518829
	CA*F3743*6D*+TXV	G*VC960804CNA*	34,600	26,200	15.0	12.5	1,190	7518830
	CA*F3743*6D*+TXV	G*VC961005CNA*	34,600	26,200	15.0	12.5	1,175	7518831
	CA*F3743*6D*+TXV	G*VC961205DNA*	34,600	26,200	15.0	12.5	1,200	7518832
CA*F3743*6D*+TXV	G*VM970603BNA*	34,200	25,800	14.5	12.2	1,250	7518833	
CA*F3743*6D*+TXV	G*VM970803BNA*	34,400	26,000	14.5	12.2	1,250	7518834	
CA*F3743*6D*+TXV	G*VM970804CNA*	34,600	26,200	15.0	12.5	1,190	7518835	
CA*F3743*6D*+TXV	G*VM971005CNA*	34,600	26,200	15.0	12.5	1,175	7518836	
CA*F3743*6D*+TXV	G*VM971205DNA*	34,600	26,200	15.0	12.5	1,200	7518837	

See Notes on Page 69.

OUTDOOR UNIT	INDOOR UNITS		COOLING RATINGS				CFM	AHRI #	
	COILS/AIR HANDLERS	FURNACES	TOTAL ¹	SENS. ¹	SEER ²	EER ³			
VSX14 0371A* (cont.)	CAPT3743*4A*	A*EC961004CNA*	34,600	26,200	14.5	12.2	1,250	7518863	
	CAPT3743*4A*	A*EC961205DNA*	34,400	26,000	15.0	12.5	1,075	7518864	
	CAPT3743*4A*	A*VC80604B*B*	33,600	25,400	14.5	12.2	1,220	7518865	
	CAPT3743*4A*	A*VC80805C*B*	33,600	25,400	15.0	12.2	1,200	7518866	
	CAPT3743*4A*	A*VC81005C*B*	33,400	25,200	15.0	12.2	1,200	7518867	
	CAPT3743*4A*	A*VC960403BNA*	34,000	25,800	14.5	12.2	1,200	7518868	
	CAPT3743*4A*	A*VC960603BNA*	34,200	25,800	14.5	12.2	1,250	7518869	
	CAPT3743*4A*	A*VC960803BNA*	34,200	25,800	14.5	12.2	1,250	7518870	
	CAPT3743*4A*	A*VC960804CNA*	34,600	26,200	15.0	12.2	1,190	7518871	
	CAPT3743*4A*	A*VC961005CNA*	34,600	26,200	15.0	12.2	1,175	7518872	
	CAPT3743*4A*	A*VC961205DNA*	34,400	26,000	15.0	12.5	1,200	7518873	
	CAPT3743*4A*	A*VM970603BNA*	34,200	25,800	14.5	12.2	1,250	7518874	
	CAPT3743*4A*	A*VM970803BNA*	34,200	25,800	14.5	12.2	1,250	7518875	
	CAPT3743*4A*	A*VM970804CNA*	34,600	26,200	15.0	12.2	1,190	7518876	
	CAPT3743*4A*	A*VM971005CNA*	34,600	26,200	15.0	12.2	1,175	7518877	
	CAPT3743*4A*	A*VM971205DNA*	34,400	26,000	15.0	12.5	1,200	7518878	
	CAPT3743*4A*	G*E80805C*B*	33,600	25,400	14.5	12.2	1,210	7518879	
	CAPT3743*4A*	G*E81005C*B*	34,000	25,800	14.5	12.2	1,200	7518880	
	CAPT3743*4A*	G*EC961004CNA*	34,600	26,200	14.5	12.2	1,250	7518881	
	CAPT3743*4A*	G*EC961205DNA*	34,400	26,000	15.0	12.5	1,075	7518882	
	CAPT3743*4A*	G*VC80604B*B*	33,600	25,400	14.5	12.2	1,220	7518883	
	CAPT3743*4A*	G*VC80805C*B*	33,600	25,400	15.0	12.2	1,200	7518884	
	CAPT3743*4A*	G*VC81005C*B*	33,400	25,200	15.0	12.2	1,200	7518885	
	CAPT3743*4A*	G*VC960403BNA*	34,000	25,800	14.5	12.2	1,200	7518886	
	CAPT3743*4A*	G*VC960603BNA*	34,200	25,800	14.5	12.2	1,250	7518887	
	CAPT3743*4A*	G*VC960803BNA*	34,200	25,800	14.5	12.2	1,250	7518888	
	CAPT3743*4A*	G*VC960804CNA*	34,600	26,200	15.0	12.2	1,190	7518889	
	CAPT3743*4A*	G*VC961005CNA*	34,600	26,200	15.0	12.2	1,175	7518890	
	CAPT3743*4A*	G*VC961205DNA*	34,400	26,000	15.0	12.5	1,200	7518891	
	CAPT3743*4A*	G*VM970603BNA*	34,200	25,800	14.5	12.2	1,250	7518892	
	CAPT3743*4A*	G*VM970803BNA*	34,200	25,800	14.5	12.2	1,250	7518893	
	CAPT3743*4A*	G*VM970804CNA*	34,600	26,200	15.0	12.2	1,190	7518894	
	CAPT3743*4A*	G*VM971005CNA*	34,600	26,200	15.0	12.2	1,175	7518895	
	CAPT3743*4A*	G*VM971205DNA*	34,400	26,000	15.0	12.5	1,200	7518896	
	CAPT3743*4A*+EEP			34,000	25,800	14.5	12.2	1,200	7518860
	CAPT3743*4A*+MBVC1600**-.1A*			34,200	25,800	14.5	12.2	1,200	7518861
	CAPT3743*4A*+MBVC1600**-.1A*+TXV			34,200	25,800	14.5	12.2	1,200	7519543
	CAPT3743*4A*+MBVC2000**-.1A*			34,200	25,800	14.5	12.2	1,200	7518862
	CAPT3743*4A*+MBVC2000**-.1A*+TXV			34,200	25,800	14.5	12.2	1,200	7519544
	CHPF3642C6C*	G*E80805C*B*		33,600	25,400	14.5	12.2	1,210	7518904
	CHPF3642C6C*	G*E81005C*B*		34,000	25,800	14.5	12.2	1,200	7518905
	CHPF3642C6C*+EEP			34,000	25,800	14.0	12.2	1,150	7518897
	CHPF3642C6C*+EEP+TXV			34,000	25,800	14.0	12.2	1,150	7518898
	CHPF3642C6C*+MBVC1600**-.1A*			34,000	25,800	14.5	12.2	1,200	7518899
	CHPF3642C6C*+MBVC1600**-.1A*+TXV			34,000	25,800	15.0	12.5	1,200	7518900
	CHPF3642C6C*+TXV	G*E80603B*B*		33,400	25,200	14.5	12.2	1,225	7518901
	CHPF3642C6C*+TXV	G*E80805C*B*		33,600	25,400	15.0	12.5	1,210	7518902
	CHPF3642C6C*+TXV	G*E81005C*B*		34,000	25,800	15.0	12.5	1,200	7518903
	CHPF3743C6B*+MBVC1600**-.1A*			34,600	26,200	14.5	12.2	1,200	7518918
	CHPF3743C6B*+MBVC1600**-.1A*+TXV			34,600	26,200	15.0	12.5	1,200	7518919
CHPF3743C6B*+TXV	A*VC80604B*B*		33,600	25,400	14.5	12.2	1,220	7518906	
CHPF3743C6B*+TXV	A*VC960403BNA*		34,200	25,800	14.5	12.2	1,200	7518907	
CHPF3743C6B*+TXV	A*VC960603BNA*		34,400	26,000	14.5	12.2	1,250	7518908	
CHPF3743C6B*+TXV	A*VC960803BNA*		34,400	26,000	14.5	12.2	1,250	7518909	
CHPF3743C6B*+TXV	A*VM970603BNA*		34,400	26,000	14.5	12.2	1,250	7518910	

See Notes on Page 69.

OUTDOOR UNIT	INDOOR UNITS		COOLING RATINGS				CFM	AHRI #	
	COILS/AIR HANDLERS	FURNACES	TOTAL ¹	SENS. ¹	SEER ²	EER ³			
VSX14 0371A* (cont.)	CHPF3743C6B*+TXV	A*VM970803BNA*	34,400	26,000	14.5	12.2	1,250	7518911	
	CHPF3743C6B*+TXV	G*VC80604B*B*	33,600	25,400	14.5	12.2	1,220	7518912	
	CHPF3743C6B*+TXV	G*VC960403BNA*	34,200	25,800	14.5	12.2	1,200	7518913	
	CHPF3743C6B*+TXV	G*VC960603BNA*	34,400	26,000	14.5	12.2	1,250	7518914	
	CHPF3743C6B*+TXV	G*VC960803BNA*	34,400	26,000	14.5	12.2	1,250	7518915	
	CHPF3743C6B*+TXV	G*VM970603BNA*	34,400	26,000	14.5	12.2	1,250	7518916	
	CHPF3743C6B*+TXV	G*VM970803BNA*	34,400	26,000	14.5	12.2	1,250	7518917	
	CHPF3743D6B*	A*EC961004CNA*	34,600	26,200	14.5	12.2	1,250	7518944	
	CHPF3743D6B*	A*EC961205DNA*	34,200	25,800	15.0	12.5	1,075	7518945	
	CHPF3743D6B*	A*VC80805C*B*	33,600	25,400	14.5	12.2	1,200	7518946	
	CHPF3743D6B*	A*VC81005C*B*	33,400	25,200	14.5	12.2	1,200	7518947	
	CHPF3743D6B*	A*VC960804CNA*	34,600	26,200	14.5	12.2	1,190	7518948	
	CHPF3743D6B*	A*VC961005CNA*	34,600	26,200	14.5	12.2	1,175	7518949	
	CHPF3743D6B*	A*VC961205DNA*	34,600	26,200	15.0	12.5	1,200	7518950	
	CHPF3743D6B*	A*VM970804CNA*	34,600	26,200	14.5	12.2	1,190	7518951	
	CHPF3743D6B*	A*VM971005CNA*	34,600	26,200	14.5	12.2	1,175	7518952	
	CHPF3743D6B*	A*VM971205DNA*	34,600	26,200	15.0	12.5	1,200	7518953	
	CHPF3743D6B*	G*EC961004CNA*	34,600	26,200	14.5	12.2	1,250	7518954	
	CHPF3743D6B*	G*EC961205DNA*	34,200	25,800	15.0	12.5	1,075	7518955	
	CHPF3743D6B*	G*VC80805C*B*	33,600	25,400	14.5	12.2	1,200	7518956	
	CHPF3743D6B*	G*VC81005C*B*	33,400	25,200	14.5	12.2	1,200	7518957	
	CHPF3743D6B*	G*VC960804CNA*	34,600	26,200	14.5	12.2	1,190	7518958	
	CHPF3743D6B*	G*VC961005CNA*	34,600	26,200	14.5	12.2	1,175	7518959	
	CHPF3743D6B*	G*VC961205DNA*	34,600	26,200	15.0	12.5	1,200	7518960	
	CHPF3743D6B*	G*VM970804CNA*	34,600	26,200	14.5	12.2	1,190	7518961	
	CHPF3743D6B*	G*VM971005CNA*	34,600	26,200	14.5	12.2	1,175	7518962	
	CHPF3743D6B*	G*VM971205DNA*	34,600	26,200	15.0	12.5	1,200	7518963	
	CHPF3743D6B*+EEP			34,600	26,200	14.5	12.2	1,150	7518921
	CHPF3743D6B*+EEP+TXV			34,600	26,200	15.0	12.5	1,150	7518922
	CHPF3743D6B*+TXV	A*EC961004CNA*		34,600	26,200	15.0	12.5	1,250	7518924
	CHPF3743D6B*+TXV	A*EC961205DNA*		34,200	25,800	15.0	12.5	1,075	7518925
	CHPF3743D6B*+TXV	A*VC80805C*B*		33,600	25,400	15.0	12.5	1,200	7518926
	CHPF3743D6B*+TXV	A*VC81005C*B*		33,400	25,200	15.0	12.5	1,200	7518927
	CHPF3743D6B*+TXV	A*VC960804CNA*		34,600	26,200	15.0	12.5	1,190	7518928
	CHPF3743D6B*+TXV	A*VC961005CNA*		34,600	26,200	15.0	12.5	1,175	7518929
	CHPF3743D6B*+TXV	A*VC961205DNA*		34,600	26,200	15.0	12.5	1,200	7518930
	CHPF3743D6B*+TXV	A*VM970804CNA*		34,600	26,200	15.0	12.5	1,190	7518931
	CHPF3743D6B*+TXV	A*VM971005CNA*		34,600	26,200	15.0	12.5	1,175	7518932
	CHPF3743D6B*+TXV	A*VM971205DNA*		34,600	26,200	15.0	12.5	1,200	7518933
	CHPF3743D6B*+TXV	G*EC961004CNA*		34,600	26,200	15.0	12.5	1,250	7518934
	CHPF3743D6B*+TXV	G*EC961205DNA*		34,200	25,800	15.0	12.5	1,075	7518935
	CHPF3743D6B*+TXV	G*VC80805C*B*		33,600	25,400	15.0	12.5	1,200	7518936
	CHPF3743D6B*+TXV	G*VC81005C*B*		33,400	25,200	15.0	12.5	1,200	7518937
	CHPF3743D6B*+TXV	G*VC960804CNA*		34,600	26,200	15.0	12.5	1,190	7518938
	CHPF3743D6B*+TXV	G*VC961005CNA*		34,600	26,200	15.0	12.5	1,175	7518939
	CHPF3743D6B*+TXV	G*VC961205DNA*		34,600	26,200	15.0	12.5	1,200	7518940
	CHPF3743D6B*+TXV	G*VM970804CNA*		34,600	26,200	15.0	12.5	1,190	7518941
	CHPF3743D6B*+TXV	G*VM971005CNA*		34,600	26,200	15.0	12.5	1,175	7518942
	CHPF3743D6B*+TXV	G*VM971205DNA*		34,600	26,200	15.0	12.5	1,200	7518943
	CSCF4860N6D*	A*EC961004CNA*		34,600	26,200	14.5	12.2	1,250	7519001
	CSCF4860N6D*	A*EC961205DNA*		34,200	25,800	15.0	12.5	1,075	7519002
	CSCF4860N6D*	A*VC80805C*B*		33,600	25,400	14.5	12.2	1,200	7519003
CSCF4860N6D*	A*VC81005C*B*		33,400	25,200	14.5	12.2	1,200	7519004	
CSCF4860N6D*	A*VC960804CNA*		34,600	26,200	14.5	12.2	1,190	7519005	
CSCF4860N6D*	A*VC961005CNA*		34,600	26,200	14.5	12.2	1,175	7519006	

See Notes on Page 69.

OUTDOOR UNIT	INDOOR UNITS		COOLING RATINGS				CFM	AHRI #
	COILS/AIR HANDLERS	FURNACES	TOTAL ¹	SENS. ¹	SEER ²	EER ³		
VSX14 0371A* (cont.)	CSCF4860N6D*	A*VC961205DNA*	34,600	26,200	15.0	12.5	1,200	7519007
	CSCF4860N6D*	A*VM970804CNA*	34,600	26,200	14.5	12.2	1,190	7519008
	CSCF4860N6D*	A*VM971005CNA*	34,600	26,200	14.5	12.2	1,175	7519009
	CSCF4860N6D*	A*VM971205DNA*	34,600	26,200	15.0	12.5	1,200	7519010
	CSCF4860N6D*	G*E80805C*B*	33,600	25,400	14.5	12.2	1,210	7519011
	CSCF4860N6D*	G*E81005C*B*	34,000	25,800	14.5	12.2	1,200	7519012
	CSCF4860N6D*	G*EC961004CNA*	34,600	26,200	14.5	12.2	1,250	7519013
	CSCF4860N6D*	G*EC961205DNA*	34,200	25,800	15.0	12.5	1,075	7519014
	CSCF4860N6D*	G*VC80805C*B*	33,600	25,400	14.5	12.2	1,200	7519015
	CSCF4860N6D*	G*VC81005C*B*	33,400	25,200	14.5	12.2	1,200	7519016
	CSCF4860N6D*	G*VC960804CNA*	34,600	26,200	14.5	12.2	1,190	7519017
	CSCF4860N6D*	G*VC961005CNA*	34,600	26,200	14.5	12.2	1,175	7519018
	CSCF4860N6D*	G*VC961205DNA*	34,600	26,200	15.0	12.5	1,200	7519019
	CSCF4860N6D*	G*VM970804CNA*	34,600	26,200	14.5	12.2	1,190	7519020
	CSCF4860N6D*	G*VM971005CNA*	34,600	26,200	14.5	12.2	1,175	7519021
	CSCF4860N6D*	G*VM971205DNA*	34,600	26,200	15.0	12.5	1,200	7519022
	CSCF4860N6D*+EEP		34,600	26,200	14.0	12.2	1,200	7518964
	CSCF4860N6D*+EEP+TXV		34,600	26,200	14.5	12.2	1,200	7518965
	CSCF4860N6D*+TXV	A*EC961004CNA*	34,600	26,200	15.0	12.5	1,250	7518966
	CSCF4860N6D*+TXV	A*EC961205DNA*	34,200	25,800	15.0	12.5	1,075	7518967
	CSCF4860N6D*+TXV	A*VC80604B*B*	33,600	25,400	14.5	12.2	1,220	7518968
	CSCF4860N6D*+TXV	A*VC80805C*B*	33,600	25,400	15.0	12.5	1,200	7518969
	CSCF4860N6D*+TXV	A*VC81005C*B*	33,400	25,200	15.0	12.5	1,200	7518970
	CSCF4860N6D*+TXV	A*VC960403BNA*	34,200	25,800	14.5	12.2	1,200	7518971
	CSCF4860N6D*+TXV	A*VC960603BNA*	34,400	26,000	14.5	12.2	1,250	7518972
	CSCF4860N6D*+TXV	A*VC960803BNA*	34,400	26,000	14.5	12.2	1,250	7518973
	CSCF4860N6D*+TXV	A*VC960804CNA*	34,600	26,200	15.0	12.5	1,190	7518974
	CSCF4860N6D*+TXV	A*VC961005CNA*	34,600	26,200	15.0	12.5	1,175	7518975
	CSCF4860N6D*+TXV	A*VC961205DNA*	34,600	26,200	15.0	12.5	1,200	7518976
	CSCF4860N6D*+TXV	A*VM970603BNA*	34,400	26,000	14.5	12.2	1,250	7518977
	CSCF4860N6D*+TXV	A*VM970803BNA*	34,400	26,000	14.5	12.2	1,250	7518978
	CSCF4860N6D*+TXV	A*VM970804CNA*	34,600	26,200	15.0	12.5	1,190	7518979
	CSCF4860N6D*+TXV	A*VM971005CNA*	34,600	26,200	15.0	12.5	1,175	7518980
	CSCF4860N6D*+TXV	A*VM971205DNA*	34,600	26,200	15.0	12.5	1,200	7518981
	CSCF4860N6D*+TXV	G*E80603B*B*	33,400	25,200	14.5	12.2	1,225	7518982
	CSCF4860N6D*+TXV	G*E80805C*B*	33,600	25,400	15.0	12.5	1,210	7518983
	CSCF4860N6D*+TXV	G*E81005C*B*	34,000	25,800	15.0	12.5	1,200	7518984
	CSCF4860N6D*+TXV	G*EC961004CNA*	34,600	26,200	15.0	12.5	1,250	7518985
	CSCF4860N6D*+TXV	G*EC961205DNA*	34,200	25,800	15.0	12.5	1,075	7518986
	CSCF4860N6D*+TXV	G*VC80604B*B*	33,600	25,400	14.5	12.2	1,220	7518987
	CSCF4860N6D*+TXV	G*VC80805C*B*	33,600	25,400	15.0	12.5	1,200	7518988
	CSCF4860N6D*+TXV	G*VC81005C*B*	33,400	25,200	15.0	12.5	1,200	7518989
	CSCF4860N6D*+TXV	G*VC960403BNA*	34,200	25,800	14.5	12.2	1,200	7518990
	CSCF4860N6D*+TXV	G*VC960603BNA*	34,400	26,000	14.5	12.2	1,250	7518991
	CSCF4860N6D*+TXV	G*VC960803BNA*	34,400	26,000	14.5	12.2	1,250	7518992
	CSCF4860N6D*+TXV	G*VC960804CNA*	34,600	26,200	15.0	12.5	1,190	7518993
	CSCF4860N6D*+TXV	G*VC961005CNA*	34,600	26,200	15.0	12.5	1,175	7518994
	CSCF4860N6D*+TXV	G*VC961205DNA*	34,600	26,200	15.0	12.5	1,200	7518995
	CSCF4860N6D*+TXV	G*VM970603BNA*	34,400	26,000	14.5	12.2	1,250	7518996
	CSCF4860N6D*+TXV	G*VM970803BNA*	34,400	26,000	14.5	12.2	1,250	7518997
	CSCF4860N6D*+TXV	G*VM970804CNA*	34,600	26,200	15.0	12.5	1,190	7518998
	CSCF4860N6D*+TXV	G*VM971005CNA*	34,600	26,200	15.0	12.5	1,175	7518999
CSCF4860N6D*+TXV	G*VM971205DNA*	34,600	26,200	15.0	12.5	1,200	7519000	

See Notes on Page 69.

OUTDOOR UNIT	INDOOR UNITS		COOLING RATINGS				CFM	AHRI #
	COILS/AIR HANDLERS	FURNACES	TOTAL ¹	SENS. ¹	SEER ²	EER ³		
VSX14 0421A*	ARUF43D14A*		37,400	29,600	14.0	11.5	1,270	8171729
	ARUF43D14A*+TXV		37,600	29,800	14.0	11.5	1,270	8171730
	ARUF47D14A*		37,600	29,800	14.0	11.5	1,375	7984213
	ASPT48D14A*		38,000	30,000	15.0	12.5	1,385	7519023
	ASPT60D14A*		38,000	30,000	15.0	12.5	1,385	7519024
	AVPTC48D14A*		38,000	30,000	15.0	12.5	1,310	7519025
	CA*F4860*6D*	A*EC961004CNA*	38,000	30,000	14.0	11.5	1,275	7519049
	CA*F4860*6D*	A*EC961205DNA*	38,000	30,000	14.0	11.5	1,400	7519050
	CA*F4860*6D*	A*VC80805C*B*	38,000	30,000	14.0	11.5	1,400	7519051
	CA*F4860*6D*	A*VC81005C*B*	38,000	30,000	14.0	11.5	1,370	7519052
	CA*F4860*6D*	A*VC960804CNA*	38,000	30,000	14.0	11.5	1,385	7519053
	CA*F4860*6D*	A*VC961005CNA*	38,000	30,000	14.0	11.5	1,300	7519054
	CA*F4860*6D*	A*VM971005CNA*	38,000	30,000	14.0	11.5	1,300	7519055
	CA*F4860*6D*	A*VM971205DNA*	38,000	30,000	14.0	11.5	1,300	7519056
	CA*F4860*6D*	G*E80805C*B*	38,000	30,000	14.0	11.5	1,425	7519057
	CA*F4860*6D*	G*E80805D*A*	38,000	30,000	14.0	11.5	1,425	7519058
	CA*F4860*6D*	G*E81005C*B*	38,000	30,000	14.0	11.5	1,425	7519059
	CA*F4860*6D*	G*EC961004CNA*	38,000	30,000	14.0	11.5	1,275	7519060
	CA*F4860*6D*	G*EC961205DNA*	38,000	30,000	14.0	11.5	1,400	7519061
	CA*F4860*6D*	G*VC80805C*B*	38,000	30,000	14.0	11.5	1,400	7519062
	CA*F4860*6D*	G*VC81005C*B*	38,000	30,000	14.0	11.5	1,370	7519063
	CA*F4860*6D*	G*VC960804CNA*	38,000	30,000	14.0	11.5	1,385	7519064
	CA*F4860*6D*	G*VC961005CNA*	38,000	30,000	14.0	11.5	1,300	7519065
	CA*F4860*6D*	G*VM971005CNA*	38,000	30,000	14.0	11.5	1,300	7519066
	CA*F4860*6D*	G*VM971205DNA*	38,000	30,000	14.0	11.5	1,300	7519067
	CA*F4860*6D*	A*VC961205DNA*	38,000	30,000	14.0	11.5	1,425	7520405
	CA*F4860*6D*	A*VM970804CNA*	38,000	30,000	14.0	11.5	1,425	7520406
	CA*F4860*6D*	G*VC961205DNA*	38,000	30,000	14.0	11.5	1,425	7520407
	CA*F4860*6D*	G*VM970804CNA*	38,000	30,000	14.0	11.5	1,425	7520408
	CA*F4860*6D*+EEP		38,000	30,000	14.0	11.5	1,400	7519026
	CA*F4860*6D*+EEP+TXV		38,000	30,000	14.0	11.5	1,400	7519027
	CA*F4860*6D*+MBVC1600*-1A*		38,000	30,000	14.5	11.5	1,300	7519028
	CA*F4860*6D*+MBVC2000*-1A*		38,000	30,000	14.5	11.5	1,300	7519029
	CA*F4860*6D*+TXV	A*EC961004CNA*	38,000	30,000	14.5	11.5	1,275	7519030
	CA*F4860*6D*+TXV	A*EC961205DNA*	38,000	30,000	14.5	11.5	1,400	7519031
	CA*F4860*6D*+TXV	A*VC80805C*B*	38,000	30,000	14.5	11.5	1,400	7519032
	CA*F4860*6D*+TXV	A*VC81005C*B*	38,000	30,000	14.5	11.5	1,370	7519033
	CA*F4860*6D*+TXV	A*VC960804CNA*	38,000	30,000	14.5	11.5	1,385	7519034
	CA*F4860*6D*+TXV	A*VC961005CNA*	38,000	30,000	14.5	11.5	1,300	7519035
	CA*F4860*6D*+TXV	A*VM971005CNA*	38,000	30,000	14.5	11.5	1,300	7519036
	CA*F4860*6D*+TXV	A*VM971205DNA*	38,000	30,000	14.5	11.5	1,300	7519037
	CA*F4860*6D*+TXV	G*E80805C*B*	38,000	30,000	14.5	11.5	1,425	7519038
	CA*F4860*6D*+TXV	G*E80805D*A*	38,000	30,000	14.5	11.5	1,425	7519039
	CA*F4860*6D*+TXV	G*E81005C*B*	38,000	30,000	14.5	11.5	1,425	7519040
	CA*F4860*6D*+TXV	G*EC961004CNA*	38,000	30,000	14.5	11.5	1,275	7519041
	CA*F4860*6D*+TXV	G*EC961205DNA*	38,000	30,000	14.5	11.5	1,400	7519042
	CA*F4860*6D*+TXV	G*VC80805C*B*	38,000	30,000	14.5	11.5	1,400	7519043
	CA*F4860*6D*+TXV	G*VC81005C*B*	38,000	30,000	14.5	11.5	1,370	7519044
	CA*F4860*6D*+TXV	G*VC960804CNA*	38,000	30,000	14.5	11.5	1,385	7519045
	CA*F4860*6D*+TXV	G*VC961005CNA*	38,000	30,000	14.5	11.5	1,300	7519046
CA*F4860*6D*+TXV	G*VM971005CNA*	38,000	30,000	14.5	11.5	1,300	7519047	
CA*F4860*6D*+TXV	G*VM971205DNA*	38,000	30,000	14.5	11.5	1,300	7519048	
CA*F4860*6D*+TXV	A*VC961205DNA*	38,000	30,000	14.5	11.5	1,425	7520401	
CA*F4860*6D*+TXV	A*VM970804CNA*	38,000	30,000	14.5	11.5	1,425	7520402	
CA*F4860*6D*+TXV	G*VC961205DNA*	38,000	30,000	14.5	11.5	1,425	7520403	

See Notes on Page 69.

OUTDOOR UNIT	INDOOR UNITS		COOLING RATINGS				CFM	AHRI #
	COILS/AIR HANDLERS	FURNACES	TOTAL ¹	SENS. ¹	SEER ²	EER ³		
VSX14 0421A* (cont.)	CA*F4860*6D*+TXV	G*VM970804CNA*	38,000	30,000	14.5	11.5	1,425	7520404
	CA*F4961*6D*	A*EC961004CNA*	39,000	30,800	14.5	12.2	1,275	7519095
	CA*F4961*6D*	A*EC961205DNA*	39,000	30,800	14.5	12.2	1,400	7519096
	CA*F4961*6D*	A*VC80805C*B*	39,000	30,800	14.5	12.2	1,400	7519097
	CA*F4961*6D*	A*VC81005C*B*	39,000	30,800	14.5	12.2	1,370	7519098
	CA*F4961*6D*	A*VC960804CNA*	39,000	30,800	14.5	12.2	1,385	7519099
	CA*F4961*6D*	A*VC961005CNA*	39,000	30,800	14.5	12.2	1,300	7519100
	CA*F4961*6D*	A*VC961205DNA*	39,000	30,800	14.5	12.2	1,450	7519101
	CA*F4961*6D*	A*VM970804CNA*	39,000	30,800	14.5	12.2	1,430	7519102
	CA*F4961*6D*	A*VM971005CNA*	39,000	30,800	14.5	12.2	1,300	7519103
	CA*F4961*6D*	A*VM971205DNA*	39,000	30,800	14.5	12.2	1,300	7519104
	CA*F4961*6D*	G*E80805C*B*	39,000	30,800	14.5	12.2	1,425	7519105
	CA*F4961*6D*	G*E80805D*A*	39,000	30,800	14.5	12.2	1,425	7519106
	CA*F4961*6D*	G*E81005C*B*	39,000	30,800	14.5	12.2	1,425	7519107
	CA*F4961*6D*	G*EC961004CNA*	39,000	30,800	14.5	12.2	1,275	7519108
	CA*F4961*6D*	G*EC961205DNA*	39,000	30,800	14.5	12.2	1,400	7519109
	CA*F4961*6D*	G*VC80805C*B*	39,000	30,800	14.5	12.2	1,400	7519110
	CA*F4961*6D*	G*VC81005C*B*	39,000	30,800	14.5	12.2	1,370	7519111
	CA*F4961*6D*	G*VC960804CNA*	39,000	30,800	14.5	12.2	1,385	7519112
	CA*F4961*6D*	G*VC961005CNA*	39,000	30,800	14.5	12.2	1,300	7519113
	CA*F4961*6D*	G*VC961205DNA*	39,000	30,800	14.5	12.2	1,450	7519114
	CA*F4961*6D*	G*VM970804CNA*	39,000	30,800	14.5	12.2	1,430	7519115
	CA*F4961*6D*	G*VM971005CNA*	39,000	30,800	14.5	12.2	1,300	7519116
	CA*F4961*6D*	G*VM971205DNA*	39,000	30,800	14.5	12.2	1,300	7519117
	CA*F4961*6D*+EEP		39,000	30,800	14.0	12.2	1,400	7519068
	CA*F4961*6D*+EEP+TXV		39,000	30,800	14.0	12.2	1,400	7519069
	CA*F4961*6D*+MBVC1600**-1A*		39,000	30,800	14.5	12.2	1,300	7519070
	CA*F4961*6D*+MBVC2000**-1A*		39,000	30,800	14.5	12.2	1,300	7519071
	CA*F4961*6D*+TXV	A*EC961004CNA*	39,000	30,800	14.5	12.2	1,275	7519072
	CA*F4961*6D*+TXV	A*EC961205DNA*	39,000	30,800	14.5	12.2	1,400	7519073
	CA*F4961*6D*+TXV	A*VC80805C*B*	39,000	30,800	14.5	12.2	1,400	7519074
	CA*F4961*6D*+TXV	A*VC81005C*B*	39,000	30,800	14.5	12.2	1,370	7519075
	CA*F4961*6D*+TXV	A*VC960804CNA*	39,000	30,800	14.5	12.2	1,385	7519076
	CA*F4961*6D*+TXV	A*VC961005CNA*	39,000	30,800	14.5	12.2	1,300	7519077
	CA*F4961*6D*+TXV	A*VC961205DNA*	39,000	30,800	14.5	12.2	1,450	7519078
	CA*F4961*6D*+TXV	A*VM970804CNA*	39,000	30,800	14.5	12.2	1,430	7519079
	CA*F4961*6D*+TXV	A*VM971005CNA*	39,000	30,800	14.5	12.2	1,300	7519080
	CA*F4961*6D*+TXV	A*VM971205DNA*	39,000	30,800	14.5	12.2	1,300	7519081
	CA*F4961*6D*+TXV	G*E80805C*B*	39,000	30,800	14.5	12.2	1,425	7519082
	CA*F4961*6D*+TXV	G*E80805D*A*	39,000	30,800	14.5	12.2	1,425	7519083
	CA*F4961*6D*+TXV	G*E81005C*B*	39,000	30,800	14.5	12.2	1,425	7519084
	CA*F4961*6D*+TXV	G*EC961004CNA*	39,000	30,800	14.5	12.2	1,275	7519085
	CA*F4961*6D*+TXV	G*EC961205DNA*	39,000	30,800	14.5	12.2	1,400	7519086
	CA*F4961*6D*+TXV	G*VC80805C*B*	39,000	30,800	14.5	12.2	1,400	7519087
	CA*F4961*6D*+TXV	G*VC81005C*B*	39,000	30,800	14.5	12.2	1,370	7519088
	CA*F4961*6D*+TXV	G*VC960804CNA*	39,000	30,800	14.5	12.2	1,385	7519089
CA*F4961*6D*+TXV	G*VC961005CNA*	39,000	30,800	14.5	12.2	1,300	7519090	
CA*F4961*6D*+TXV	G*VC961205DNA*	39,000	30,800	14.5	12.2	1,450	7519091	
CA*F4961*6D*+TXV	G*VM970804CNA*	39,000	30,800	14.5	12.2	1,430	7519092	
CA*F4961*6D*+TXV	G*VM971005CNA*	39,000	30,800	14.5	12.2	1,300	7519093	
CA*F4961*6D*+TXV	G*VM971205DNA*	39,000	30,800	14.5	12.2	1,300	7519094	
CAPT4961*4A*	A*VC80805C*B*	39,000	30,800	14.5	11.5	1,425	7519121	
CAPT4961*4A*	A*VC81005C*B*	39,000	30,800	14.5	11.5	1,370	7519122	
CAPT4961*4A*	A*VC960804CNA*	39,000	30,800	14.5	11.5	1,385	7519123	
CAPT4961*4A*	A*VC961005CNA*	39,000	30,800	14.5	11.5	1,300	7519124	

See Notes on Page 69.

OUTDOOR UNIT	INDOOR UNITS		COOLING RATINGS				CFM	AHRI #
	COILS/AIR HANDLERS	FURNACES	TOTAL ¹	SENS. ¹	SEER ²	EER ³		
VSX14 0421A* (cont.)	CAPT4961*4A*	A*VC961205DNA*	39,000	30,800	14.5	11.5	1,450	7519125
	CAPT4961*4A*	A*VM970804CNA*	39,000	30,800	14.5	11.5	1,430	7519126
	CAPT4961*4A*	A*VM971005CNA*	39,000	30,800	14.5	11.5	1,300	7519127
	CAPT4961*4A*	A*VM971205DNA*	39,000	30,800	14.5	11.5	1,300	7519128
	CAPT4961*4A*	G*E80805C*B*	39,000	30,800	14.5	11.5	1,425	7519129
	CAPT4961*4A*	G*E81005C*B*	39,000	30,800	14.5	11.5	1,425	7519130
	CAPT4961*4A*	G*VC80805C*B*	39,000	30,800	14.5	11.5	1,425	7519131
	CAPT4961*4A*	G*VC81005C*B*	39,000	30,800	14.5	11.5	1,370	7519132
	CAPT4961*4A*	G*VC960804CNA*	39,000	30,800	14.5	11.5	1,385	7519133
	CAPT4961*4A*	G*VC961005CNA*	39,000	30,800	14.5	11.5	1,300	7519134
	CAPT4961*4A*	G*VC961205DNA*	39,000	30,800	14.5	11.5	1,450	7519135
	CAPT4961*4A*	G*VM970804CNA*	39,000	30,800	14.5	11.5	1,430	7519136
	CAPT4961*4A*	G*VM971005CNA*	39,000	30,800	14.5	11.5	1,300	7519137
	CAPT4961*4A*	G*VM971205DNA*	39,000	30,800	14.5	11.5	1,300	7519138
	CAPT4961*4A*+EEP		39,000	30,800	14.0	11.5	1,275	7519118
	CAPT4961*4A*+MBVC1600**-1A*		39,000	30,800	14.5	12.2	1,300	7519119
	CAPT4961*4A*+MBVC2000**-1A*		39,000	30,800	14.5	12.2	1,300	7519120
	CHPF4860D6D*	A*EC961004CNA*	38,000	30,000	14.5	12.2	1,275	7519160
	CHPF4860D6D*	A*EC961205DNA*	38,000	30,000	14.5	12.2	1,400	7519161
	CHPF4860D6D*	A*VC80805C*B*	38,000	30,000	14.5	12.2	1,400	7519162
	CHPF4860D6D*	A*VC81005C*B*	38,000	30,000	14.5	12.2	1,370	7519163
	CHPF4860D6D*	A*VC960804CNA*	38,000	30,000	14.5	12.2	1,385	7519164
	CHPF4860D6D*	A*VC961005CNA*	38,000	30,000	14.5	12.2	1,300	7519165
	CHPF4860D6D*	A*VM971005CNA*	38,000	30,000	14.5	12.2	1,300	7519166
	CHPF4860D6D*	A*VM971205DNA*	38,000	30,000	14.5	12.2	1,300	7519167
	CHPF4860D6D*	G*E80805C*B*	38,000	30,000	14.5	12.2	1,425	7519168
	CHPF4860D6D*	G*E80805D*A*	38,000	30,000	14.5	12.2	1,425	7519169
	CHPF4860D6D*	G*E81005C*B*	38,000	30,000	14.5	12.2	1,425	7519170
	CHPF4860D6D*	G*EC961004CNA*	38,000	30,000	14.5	12.2	1,275	7519171
	CHPF4860D6D*	G*EC961205DNA*	38,000	30,000	14.5	12.2	1,400	7519172
	CHPF4860D6D*	G*VC80805C*B*	38,000	30,000	14.5	12.2	1,400	7519173
	CHPF4860D6D*	G*VC81005C*B*	38,000	30,000	14.5	12.2	1,370	7519174
	CHPF4860D6D*	G*VC960804CNA*	38,000	30,000	14.5	12.2	1,385	7519175
	CHPF4860D6D*	G*VC961005CNA*	38,000	30,000	14.5	12.2	1,300	7519176
	CHPF4860D6D*	G*VM971005CNA*	38,000	30,000	14.5	12.2	1,300	7519177
	CHPF4860D6D*	G*VM971205DNA*	38,000	30,000	14.5	12.2	1,300	7519178
	CHPF4860D6D*	A*VC961205DNA*	38,000	30,000	14.5	12.2	1,425	7520415
	CHPF4860D6D*	A*VM970804CNA*	38,000	30,000	14.5	12.2	1,425	7520416
	CHPF4860D6D*	G*VC961205DNA*	38,000	30,000	14.5	12.2	1,425	7520417
	CHPF4860D6D*	G*VM970804CNA*	38,000	30,000	14.5	12.2	1,425	7520418
	CHPF4860D6D*+EEP		38,000	30,000	14.0	12.0	1,425	7520409
	CHPF4860D6D*+EEP+TXV		38,000	30,000	14.0	12.2	1,425	7520410
	CHPF4860D6D*+MBVC1600**-1A*		38,000	30,000	14.5	12.2	1,400	7519139
	CHPF4860D6D*+MBVC2000**-1A*		38,000	30,000	14.5	12.2	1,400	7519140
	CHPF4860D6D*+TXV	A*EC961004CNA*	38,000	30,000	14.5	12.2	1,275	7519141
	CHPF4860D6D*+TXV	A*EC961205DNA*	38,000	30,000	14.5	12.2	1,400	7519142
	CHPF4860D6D*+TXV	A*VC80805C*B*	38,000	30,000	14.5	12.2	1,400	7519143
	CHPF4860D6D*+TXV	A*VC81005C*B*	38,000	30,000	14.5	12.2	1,370	7519144
	CHPF4860D6D*+TXV	A*VC960804CNA*	38,000	30,000	14.5	12.2	1,385	7519145
	CHPF4860D6D*+TXV	A*VC961005CNA*	38,000	30,000	14.5	12.2	1,300	7519146
CHPF4860D6D*+TXV	A*VM971005CNA*	38,000	30,000	14.5	12.2	1,300	7519147	
CHPF4860D6D*+TXV	A*VM971205DNA*	38,000	30,000	14.5	12.2	1,300	7519148	
CHPF4860D6D*+TXV	G*E80805C*B*	38,000	30,000	14.5	12.2	1,425	7519149	
CHPF4860D6D*+TXV	G*E80805D*A*	38,000	30,000	14.5	12.2	1,425	7519150	
CHPF4860D6D*+TXV	G*E81005C*B*	38,000	30,000	14.5	12.2	1,425	7519151	

See Notes on Page 69.

OUTDOOR UNIT	INDOOR UNITS		COOLING RATINGS				CFM	AHRI #
	COILS/AIR HANDLERS	FURNACES	TOTAL ¹	SENS. ¹	SEER ²	EER ³		
VSX14 0421A* (cont.)	CHPF4860D6D*+TXV	G*EC961004CNA*	38,000	30,000	14.5	12.2	1,275	7519152
	CHPF4860D6D*+TXV	G*EC961205DNA*	38,000	30,000	14.5	12.2	1,400	7519153
	CHPF4860D6D*+TXV	G*VC80805C*B*	38,000	30,000	14.5	12.2	1,400	7519154
	CHPF4860D6D*+TXV	G*VC81005C*B*	38,000	30,000	14.5	12.2	1,370	7519155
	CHPF4860D6D*+TXV	G*VC960804CNA*	38,000	30,000	14.5	12.2	1,385	7519156
	CHPF4860D6D*+TXV	G*VC961005CNA*	38,000	30,000	14.5	12.2	1,300	7519157
	CHPF4860D6D*+TXV	G*VM971005CNA*	38,000	30,000	14.5	12.2	1,300	7519158
	CHPF4860D6D*+TXV	G*VM971205DNA*	38,000	30,000	14.5	12.2	1,300	7519159
	CHPF4860D6D*+TXV	A*VC961205DNA*	38,000	30,000	14.5	12.2	1,425	7520411
	CHPF4860D6D*+TXV	A*VM970804CNA*	38,000	30,000	14.5	12.2	1,425	7520412
	CHPF4860D6D*+TXV	G*VC961205DNA*	38,000	30,000	14.5	12.2	1,425	7520413
	CHPF4860D6D*+TXV	G*VM970804CNA*	38,000	30,000	14.5	12.2	1,425	7520414
	CSCF4860N6D*	A*EC961004CNA*	38,000	30,000	14.5	12.2	1,275	7519198
	CSCF4860N6D*	A*EC961205DNA*	38,000	30,000	14.5	12.2	1,400	7519199
	CSCF4860N6D*	A*VC80805C*B*	38,000	30,000	14.5	11.5	1,400	7519200
	CSCF4860N6D*	A*VC81005C*B*	38,000	30,000	14.5	11.5	1,370	7519201
	CSCF4860N6D*	A*VC960804CNA*	38,000	30,000	14.5	11.5	1,385	7519202
	CSCF4860N6D*	A*VC961005CNA*	38,000	30,000	14.5	11.5	1,300	7519203
	CSCF4860N6D*	A*VM971005CNA*	38,000	30,000	14.5	11.5	1,300	7519204
	CSCF4860N6D*	A*VM971205DNA*	38,000	30,000	14.5	11.5	1,300	7519205
	CSCF4860N6D*	G*E80805C*B*	38,000	30,000	14.5	11.5	1,425	7519206
	CSCF4860N6D*	G*E80805D*A*	38,000	30,000	14.5	11.5	1,425	7519207
	CSCF4860N6D*	G*E81005C*B*	38,000	30,000	14.5	11.5	1,425	7519208
	CSCF4860N6D*	G*EC961004CNA*	38,000	30,000	14.5	12.2	1,275	7519209
	CSCF4860N6D*	G*EC961205DNA*	38,000	30,000	14.5	12.2	1,400	7519210
	CSCF4860N6D*	G*VC80805C*B*	38,000	30,000	14.5	11.5	1,400	7519211
	CSCF4860N6D*	G*VC81005C*B*	38,000	30,000	14.5	11.5	1,370	7519212
	CSCF4860N6D*	G*VC960804CNA*	38,000	30,000	14.5	11.5	1,385	7519213
	CSCF4860N6D*	G*VC961005CNA*	38,000	30,000	14.5	11.5	1,300	7519214
	CSCF4860N6D*	G*VM971005CNA*	38,000	30,000	14.5	11.5	1,300	7519215
	CSCF4860N6D*	G*VM971205DNA*	38,000	30,000	14.5	11.5	1,300	7519216
	CSCF4860N6D*	A*VC961205DNA*	38,000	30,000	14.5	11.5	1,425	7520425
	CSCF4860N6D*	A*VM970804CNA*	38,000	30,000	14.5	11.5	1,425	7520426
	CSCF4860N6D*	G*VC961205DNA*	38,000	30,000	14.5	11.5	1,425	7520427
	CSCF4860N6D*	G*VM970804CNA*	38,000	30,000	14.5	11.5	1,425	7520428
	CSCF4860N6D*+EEP		38,000	30,000	14.0	11.5	1,425	7520419
	CSCF4860N6D*+EEP+TXV		38,000	30,000	14.0	11.5	1,425	7520420
	CSCF4860N6D*+TXV	A*EC961004CNA*	38,000	30,000	14.5	12.2	1,275	7519179
	CSCF4860N6D*+TXV	A*EC961205DNA*	38,000	30,000	14.5	12.2	1,400	7519180
	CSCF4860N6D*+TXV	A*VC80805C*B*	38,000	30,000	14.5	11.5	1,400	7519181
	CSCF4860N6D*+TXV	A*VC81005C*B*	38,000	30,000	14.5	11.5	1,370	7519182
	CSCF4860N6D*+TXV	A*VC960804CNA*	38,000	30,000	14.5	11.5	1,385	7519183
	CSCF4860N6D*+TXV	A*VC961005CNA*	38,000	30,000	14.5	11.5	1,300	7519184
	CSCF4860N6D*+TXV	A*VM971005CNA*	38,000	30,000	14.5	11.5	1,300	7519185
	CSCF4860N6D*+TXV	A*VM971205DNA*	38,000	30,000	14.5	11.5	1,300	7519186
	CSCF4860N6D*+TXV	G*E80805C*B*	38,000	30,000	14.5	11.5	1,425	7519187
	CSCF4860N6D*+TXV	G*E80805D*A*	38,000	30,000	14.5	11.5	1,425	7519188
	CSCF4860N6D*+TXV	G*E81005C*B*	38,000	30,000	14.5	11.5	1,425	7519189
	CSCF4860N6D*+TXV	G*EC961004CNA*	38,000	30,000	14.5	12.2	1,275	7519190
	CSCF4860N6D*+TXV	G*EC961205DNA*	38,000	30,000	14.5	12.2	1,400	7519191
CSCF4860N6D*+TXV	G*VC80805C*B*	38,000	30,000	14.5	11.5	1,400	7519192	
CSCF4860N6D*+TXV	G*VC81005C*B*	38,000	30,000	14.5	11.5	1,370	7519193	
CSCF4860N6D*+TXV	G*VC960804CNA*	38,000	30,000	14.5	11.5	1,385	7519194	
CSCF4860N6D*+TXV	G*VC961005CNA*	38,000	30,000	14.5	11.5	1,300	7519195	
CSCF4860N6D*+TXV	G*VM971005CNA*	38,000	30,000	14.5	11.5	1,300	7519196	
CSCF4860N6D*+TXV	G*VM971205DNA*	38,000	30,000	14.5	11.5	1,300	7519197	
CSCF4860N6D*+TXV	A*VC961205DNA*	38,000	30,000	14.5	11.5	1,425	7520421	
CSCF4860N6D*+TXV	A*VM970804CNA*	38,000	30,000	14.5	11.5	1,425	7520422	
CSCF4860N6D*+TXV	G*VC961205DNA*	38,000	30,000	14.5	11.5	1,425	7520423	
CSCF4860N6D*+TXV	G*VM970804CNA*	38,000	30,000	14.5	11.5	1,425	7520424	

See Notes on Page 69.

OUTDOOR UNIT	INDOOR UNITS		COOLING RATINGS				CFM	AHRI #
	COILS/AIR HANDLERS	FURNACES	TOTAL ¹	SENS. ¹	SEER ²	EER ³		
VSX14 0431A*	ASPT48D14A*		38,000	30,000	15.0	12.5	1,385	8082510
	ASPT60D14A*		38,000	30,000	15.0	12.5	1,385	8082511
	AVPTC48D14A*		38,000	30,000	15.0	12.5	1,310	8082512
	CA*F4961*6D*	G*E80805C*B*	39,000	30,800	14.5	12.2	1,425	8082522
	CA*F4961*6D*	G*E80805D*A*	39,000	30,800	14.5	12.2	1,425	8082526
	CA*F4961*6D*	G*E81005C*B*	39,000	30,800	14.5	12.2	1,425	8082530
	CA*F4961*6D*	G*VC80805C*B*	39,000	30,800	14.5	12.2	1,400	8082534
	CA*F4961*6D*	G*VC81005C*B*	39,000	30,800	14.5	12.2	1,370	8082538
	CA*F4961*6D*	A*VC80805C*B*	39,000	30,800	14.5	12.2	1,400	8082542
	CA*F4961*6D*	A*VC81005C*B*	39,000	30,800	14.5	12.2	1,370	8082546
	CA*F4961*6D*	G*VC960804CNA*	39,000	30,800	14.5	12.2	1,385	8082550
	CA*F4961*6D*	G*VC961005CNA*	39,000	30,800	14.5	12.2	1,300	8082554
	CA*F4961*6D*	G*VC961205DNA*	39,000	30,800	14.5	12.2	1,450	8082558
	CA*F4961*6D*	A*VC960804CNA*	39,000	30,800	14.5	12.2	1,385	8082562
	CA*F4961*6D*	A*VC961005CNA*	39,000	30,800	14.5	12.2	1,300	8082566
	CA*F4961*6D*	A*VC961205DNA*	39,000	30,800	14.5	12.2	1,450	8082570
	CA*F4961*6D*	G*VM970804CNA*	39,000	30,800	14.5	12.2	1,430	8082574
	CA*F4961*6D*	G*VM971005CNA*	39,000	30,800	14.5	12.2	1,300	8082578
	CA*F4961*6D*	G*VM971205DNA*	39,000	30,800	14.5	12.2	1,300	8082582
	CA*F4961*6D*	A*VM970804CNA*	39,000	30,800	14.5	12.2	1,430	8082586
	CA*F4961*6D*	A*VM971005CNA*	39,000	30,800	14.5	12.2	1,300	8082590
	CA*F4961*6D*	A*VM971205DNA*	39,000	30,800	14.5	12.2	1,300	8082594
	CA*F4961*6D*	G*EC961004CNA*	39,000	30,800	14.5	12.2	1,275	8082598
	CA*F4961*6D*	G*EC961205DNA*	39,000	30,800	14.5	12.2	1,400	8082604
	CA*F4961*6D*	A*EC961004CNA*	39,000	30,800	14.5	12.2	1,275	8082610
	CA*F4961*6D*	A*EC961205DNA*	39,000	30,800	14.5	12.2	1,400	8082616
	CA*F4961*6D*+EEP		39,000	30,800	14.0	12.2	1,400	8082513
	CA*F4961*6D*+EEP+TXV		39,000	30,800	14.0	12.2	1,400	8082514
	CA*F4961*6D*+MBVC1600**-1A*		39,000	30,800	14.5	12.2	1,300	8082515
	CA*F4961*6D*+MBVC2000**-1A*		39,000	30,800	14.5	12.2	1,300	8082516
	CA*F4961*6D*+TXV	G*E80805C*B*	39,000	30,800	14.5	12.2	1,425	8082523
	CA*F4961*6D*+TXV	G*E80805D*A*	39,000	30,800	14.5	12.2	1,425	8082527
	CA*F4961*6D*+TXV	G*E81005C*B*	39,000	30,800	14.5	12.2	1,425	8082531
	CA*F4961*6D*+TXV	G*VC80805C*B*	39,000	30,800	14.5	12.2	1,400	8082535
	CA*F4961*6D*+TXV	G*VC81005C*B*	39,000	30,800	14.5	12.2	1,370	8082539
	CA*F4961*6D*+TXV	A*VC80805C*B*	39,000	30,800	14.5	12.2	1,400	8082543
	CA*F4961*6D*+TXV	A*VC81005C*B*	39,000	30,800	14.5	12.2	1,370	8082547
	CA*F4961*6D*+TXV	G*VC960804CNA*	39,000	30,800	14.5	12.2	1,385	8082551
	CA*F4961*6D*+TXV	G*VC961005CNA*	39,000	30,800	14.5	12.2	1,300	8082555
	CA*F4961*6D*+TXV	G*VC961205DNA*	39,000	30,800	14.5	12.2	1,450	8082559
	CA*F4961*6D*+TXV	A*VC960804CNA*	39,000	30,800	14.5	12.2	1,385	8082563
	CA*F4961*6D*+TXV	A*VC961005CNA*	39,000	30,800	14.5	12.2	1,300	8082567
	CA*F4961*6D*+TXV	A*VC961205DNA*	39,000	30,800	14.5	12.2	1,450	8082571
	CA*F4961*6D*+TXV	G*VM970804CNA*	39,000	30,800	14.5	12.2	1,430	8082575
	CA*F4961*6D*+TXV	G*VM971005CNA*	39,000	30,800	14.5	12.2	1,300	8082579
	CA*F4961*6D*+TXV	G*VM971205DNA*	39,000	30,800	14.5	12.2	1,300	8082583
	CA*F4961*6D*+TXV	A*VM970804CNA*	39,000	30,800	14.5	12.2	1,430	8082587
CA*F4961*6D*+TXV	A*VM971005CNA*	39,000	30,800	14.5	12.2	1,300	8082591	
CA*F4961*6D*+TXV	A*VM971205DNA*	39,000	30,800	14.5	12.2	1,300	8082595	
CA*F4961*6D*+TXV	G*EC961004CNA*	39,000	30,800	14.5	12.2	1,275	8082599	
CA*F4961*6D*+TXV	G*EC961205DNA*	39,000	30,800	14.5	12.2	1,400	8082605	
CA*F4961*6D*+TXV	A*EC961004CNA*	39,000	30,800	14.5	12.2	1,275	8082611	
CA*F4961*6D*+TXV	A*EC961205DNA*	39,000	30,800	14.5	12.2	1,400	8082617	
CAPT4961*4A*+MBVC1600**-1A*		39,000	30,800	14.5	12.2	1,300	8082517	
CAPT4961*4A*+MBVC2000**-1A*		39,000	30,800	14.5	12.2	1,300	8082518	

See Notes on Page 69.

OUTDOOR UNIT	INDOOR UNITS		COOLING RATINGS				CFM	AHRI #
	COILS/AIR HANDLERS	FURNACES	TOTAL ¹	SENS. ¹	SEER ²	EER ³		
VSX14 0431A* (cont.)	CHPF4860D6D*	G*E80805C*B*	38,000	30,000	14.5	12.2	1,425	8082524
	CHPF4860D6D*	G*E80805D*A*	38,000	30,000	14.5	12.2	1,425	8082528
	CHPF4860D6D*	G*E81005C*B*	38,000	30,000	14.5	12.2	1,425	8082532
	CHPF4860D6D*	G*VC80805C*B*	38,000	30,000	14.5	12.2	1,400	8082536
	CHPF4860D6D*	G*VC81005C*B*	38,000	30,000	14.5	12.2	1,370	8082540
	CHPF4860D6D*	A*VC80805C*B*	38,000	30,000	14.5	12.2	1,400	8082544
	CHPF4860D6D*	A*VC81005C*B*	38,000	30,000	14.5	12.2	1,370	8082548
	CHPF4860D6D*	G*VC960804CNA*	38,000	30,000	14.5	12.2	1,385	8082552
	CHPF4860D6D*	G*VC961005CNA*	38,000	30,000	14.5	12.2	1,300	8082556
	CHPF4860D6D*	G*VC961205DNA*	38,000	30,000	14.5	12.2	1,425	8082560
	CHPF4860D6D*	A*VC960804CNA*	38,000	30,000	14.5	12.2	1,385	8082564
	CHPF4860D6D*	A*VC961005CNA*	38,000	30,000	14.5	12.2	1,300	8082568
	CHPF4860D6D*	A*VC961205DNA*	38,000	30,000	14.5	12.2	1,425	8082572
	CHPF4860D6D*	G*VM970804CNA*	38,000	30,000	14.5	12.2	1,425	8082576
	CHPF4860D6D*	G*VM971005CNA*	38,000	30,000	14.5	12.2	1,300	8082580
	CHPF4860D6D*	G*VM971205DNA*	38,000	30,000	14.5	12.2	1,300	8082584
	CHPF4860D6D*	A*VM970804CNA*	38,000	30,000	14.5	12.2	1,425	8082588
	CHPF4860D6D*	A*VM971005CNA*	38,000	30,000	14.5	12.2	1,300	8082592
	CHPF4860D6D*	A*VM971205DNA*	38,000	30,000	14.5	12.2	1,300	8082596
	CHPF4860D6D*	G*EC961004CNA*	38,000	30,000	14.5	12.2	1,275	8082600
	CHPF4860D6D*	G*EC961205DNA*	38,000	30,000	14.5	12.2	1,400	8082606
	CHPF4860D6D*	A*EC961004CNA*	38,000	30,000	14.5	12.2	1,275	8082612
	CHPF4860D6D*	A*EC961205DNA*	38,000	30,000	14.5	12.2	1,400	8082618
	CHPF4860D6D*+EEP+TXV		38,000	30,000	14.0	12.2	1,425	8082519
	CHPF4860D6D*+MBVC1600**-1A*		38,000	30,000	14.5	12.2	1,400	8082520
	CHPF4860D6D*+MBVC2000**-1A*		38,000	30,000	14.5	12.2	1,400	8082521
	CHPF4860D6D*+TXV	G*E80805C*B*	38,000	30,000	14.5	12.2	1,425	8082525
	CHPF4860D6D*+TXV	G*E80805D*A*	38,000	30,000	14.5	12.2	1,425	8082529
	CHPF4860D6D*+TXV	G*E81005C*B*	38,000	30,000	14.5	12.2	1,425	8082533
	CHPF4860D6D*+TXV	G*VC80805C*B*	38,000	30,000	14.5	12.2	1,400	8082537
	CHPF4860D6D*+TXV	G*VC81005C*B*	38,000	30,000	14.5	12.2	1,370	8082541
	CHPF4860D6D*+TXV	A*VC80805C*B*	38,000	30,000	14.5	12.2	1,400	8082545
	CHPF4860D6D*+TXV	A*VC81005C*B*	38,000	30,000	14.5	12.2	1,370	8082549
	CHPF4860D6D*+TXV	G*VC960804CNA*	38,000	30,000	14.5	12.2	1,385	8082553
	CHPF4860D6D*+TXV	G*VC961005CNA*	38,000	30,000	14.5	12.2	1,300	8082557
	CHPF4860D6D*+TXV	G*VC961205DNA*	38,000	30,000	14.5	12.2	1,425	8082561
	CHPF4860D6D*+TXV	A*VC960804CNA*	38,000	30,000	14.5	12.2	1,385	8082565
	CHPF4860D6D*+TXV	A*VC961005CNA*	38,000	30,000	14.5	12.2	1,300	8082569
	CHPF4860D6D*+TXV	A*VC961205DNA*	38,000	30,000	14.5	12.2	1,425	8082573
	CHPF4860D6D*+TXV	G*VM970804CNA*	38,000	30,000	14.5	12.2	1,425	8082577
	CHPF4860D6D*+TXV	G*VM971005CNA*	38,000	30,000	14.5	12.2	1,300	8082581
	CHPF4860D6D*+TXV	G*VM971205DNA*	38,000	30,000	14.5	12.2	1,300	8082585
	CHPF4860D6D*+TXV	A*VM970804CNA*	38,000	30,000	14.5	12.2	1,425	8082589
	CHPF4860D6D*+TXV	A*VM971005CNA*	38,000	30,000	14.5	12.2	1,300	8082593
	CHPF4860D6D*+TXV	A*VM971205DNA*	38,000	30,000	14.5	12.2	1,300	8082597
	CHPF4860D6D*+TXV	G*EC961004CNA*	38,000	30,000	14.5	12.2	1,275	8082601
	CHPF4860D6D*+TXV	G*EC961205DNA*	38,000	30,000	14.5	12.2	1,400	8082607
	CHPF4860D6D*+TXV	A*EC961004CNA*	38,000	30,000	14.5	12.2	1,275	8082613
	CHPF4860D6D*+TXV	A*EC961205DNA*	38,000	30,000	14.5	12.2	1,400	8082619
	CSCF4860N6D*	G*EC961004CNA*	38,000	30,000	14.5	12.2	1,275	8082602
CSCF4860N6D*	G*EC961205DNA*	38,000	30,000	14.5	12.2	1,400	8082608	
CSCF4860N6D*	A*EC961004CNA*	38,000	30,000	14.5	12.2	1,275	8082614	
CSCF4860N6D*	A*EC961205DNA*	38,000	30,000	14.5	12.2	1,400	8082620	
CSCF4860N6D*+TXV	G*EC961004CNA*	38,000	30,000	14.5	12.2	1,275	8082603	
CSCF4860N6D*+TXV	G*EC961205DNA*	38,000	30,000	14.5	12.2	1,400	8082609	
CSCF4860N6D*+TXV	A*EC961004CNA*	38,000	30,000	14.5	12.2	1,275	8082615	
CSCF4860N6D*+TXV	A*EC961205DNA*	38,000	30,000	14.5	12.2	1,400	8082621	

See Notes on Page 69.

OUTDOOR UNIT	INDOOR UNITS		COOLING RATINGS				CFM	AHRI #
	COILS/AIR HANDLERS	FURNACES	TOTAL ¹	SENS. ¹	SEER ²	EER ³		
VSX14 0481A*	ARUF61D14A*		45,500	32,200	14.0	11.7	1,520	7984214
	ASPT48D14A*		46,000	32,600	14.5	11.7	1,600	7519217
	ASPT60D14A*		46,000	32,600	14.5	11.7	1,600	7519218
	AVPTC48D14A*		46,000	32,600	14.5	11.7	1,550	7519219
	AVPTC60D14A*		46,000	32,600	14.5	11.7	1,590	7519220
	CA*F4860*6D*	A*VC960804CNA*	45,000	31,800	14.5	11.7	1,385	7519246
	CA*F4860*6D*	A*VC961005CNA*	45,500	32,200	14.5	11.7	1,450	7519247
	CA*F4860*6D*	A*VC961205DNA*	45,500	32,200	14.5	11.7	1,450	7519248
	CA*F4860*6D*	A*VM970804CNA*	45,000	31,800	14.5	11.7	1,385	7519249
	CA*F4860*6D*	A*VM971005CNA*	45,500	32,200	14.5	11.7	1,450	7519250
	CA*F4860*6D*	A*VM971205DNA*	45,500	32,200	14.5	11.7	1,450	7519251
	CA*F4860*6D*	G*VC960804CNA*	45,000	31,800	14.5	11.7	1,385	7519252
	CA*F4860*6D*	G*VC961005CNA*	45,500	32,200	14.5	11.7	1,450	7519253
	CA*F4860*6D*	G*VC961205DNA*	45,500	32,200	14.5	11.7	1,450	7519254
	CA*F4860*6D*	G*VM970804CNA*	45,000	31,800	14.5	11.7	1,385	7519255
	CA*F4860*6D*	G*VM971005CNA*	45,500	32,200	14.5	11.7	1,450	7519256
	CA*F4860*6D*	G*VM971205DNA*	45,500	32,200	14.5	11.7	1,450	7519257
	CA*F4860*6D*+EEP		45,500	32,200	14.0	11.7	1,550	7519221
	CA*F4860*6D*+EEP+TXV		45,500	32,200	14.0	11.7	1,550	7519222
	CA*F4860*6D*+MBVC2000*-1A*+TXV		46,000	32,600	14.5	12.0	1,600	7519223
	CA*F4860*6D*+TXV	A*EC961004CNA*	45,000	31,800	14.5	11.7	1,525	7519224
	CA*F4860*6D*+TXV	A*EC961205DNA*	45,000	31,800	14.5	12.0	1,525	7519225
	CA*F4860*6D*+TXV	A*VC80805C*B*	45,500	32,200	14.5	11.7	1,510	7519226
	CA*F4860*6D*+TXV	A*VC81005C*B*	45,500	32,200	14.5	11.7	1,530	7519227
	CA*F4860*6D*+TXV	A*VC960804CNA*	45,000	31,800	14.5	12.0	1,385	7519228
	CA*F4860*6D*+TXV	A*VC961005CNA*	45,500	32,200	14.5	12.0	1,450	7519229
	CA*F4860*6D*+TXV	A*VC961205DNA*	45,500	32,200	14.5	12.0	1,450	7519230
	CA*F4860*6D*+TXV	A*VM970804CNA*	45,000	31,800	14.5	12.0	1,385	7519231
	CA*F4860*6D*+TXV	A*VM971005CNA*	45,500	32,200	14.5	12.0	1,450	7519232
	CA*F4860*6D*+TXV	A*VM971205DNA*	45,500	32,200	14.5	12.0	1,450	7519233
	CA*F4860*6D*+TXV	G*E80805C*B*	45,000	31,800	14.5	11.7	1,480	7519234
	CA*F4860*6D*+TXV	G*E81005C*B*	45,500	32,200	14.5	11.7	1,570	7519235
	CA*F4860*6D*+TXV	G*EC961004CNA*	45,000	31,800	14.5	11.7	1,525	7519236
	CA*F4860*6D*+TXV	G*EC961205DNA*	45,000	31,800	14.5	12.0	1,525	7519237
	CA*F4860*6D*+TXV	G*VC80805C*B*	45,500	32,200	14.5	11.7	1,510	7519238
	CA*F4860*6D*+TXV	G*VC81005C*B*	45,500	32,200	14.5	11.7	1,530	7519239
	CA*F4860*6D*+TXV	G*VC960804CNA*	45,000	31,800	14.5	12.0	1,385	7519240
	CA*F4860*6D*+TXV	G*VC961005CNA*	45,500	32,200	14.5	12.0	1,450	7519241
	CA*F4860*6D*+TXV	G*VC961205DNA*	45,500	32,200	14.5	12.0	1,450	7519242
	CA*F4860*6D*+TXV	G*VM970804CNA*	45,000	31,800	14.5	12.0	1,385	7519243
	CA*F4860*6D*+TXV	G*VM971005CNA*	45,500	32,200	14.5	12.0	1,450	7519244
	CA*F4860*6D*+TXV	G*VM971205DNA*	45,500	32,200	14.5	12.0	1,450	7519245
	CA*F4961*6D*+EEP		46,000	32,600	14.0	11.7	1,550	7519258
	CA*F4961*6D*+EEP+TXV		46,000	32,600	14.0	11.7	1,550	7519259
	CA*F4961*6D*+MBVC2000*-1A*+TXV		46,000	32,600	14.5	12.0	1,600	7519260
	CAPT4961*4A*	A*EC961004CNA*	45,000	31,800	14.5	11.7	1,525	7519262
	CAPT4961*4A*	A*EC961205DNA*	45,000	31,800	14.5	12.0	1,525	7519263
	CAPT4961*4A*	A*VC80805C*B*	45,500	32,200	14.5	11.7	1,510	7519264
	CAPT4961*4A*	A*VC81005C*B*	45,500	32,200	14.5	11.7	1,530	7519265
	CAPT4961*4A*	A*VC960804CNA*	45,000	31,800	14.5	11.7	1,385	7519266
CAPT4961*4A*	A*VC961005CNA*	45,500	32,200	14.5	11.7	1,450	7519267	
CAPT4961*4A*	A*VC961205DNA*	45,500	32,200	14.5	11.7	1,450	7519268	
CAPT4961*4A*	A*VM970804CNA*	45,000	31,800	14.5	11.7	1,385	7519269	

See Notes on Page 69.

OUTDOOR UNIT	INDOOR UNITS		COOLING RATINGS				CFM	AHRI #
	COILS/AIR HANDLERS	FURNACES	TOTAL ¹	SENS. ¹	SEER ²	EER ³		
	CAPT4961*4A*	A*VM971005CNA*	45,500	32,200	14.5	11.7	1,450	7519270
	CAPT4961*4A*	A*VM971205DNA*	45,500	32,200	14.5	11.7	1,450	7519271
	CAPT4961*4A*	G*E80805C*B*	45,000	31,800	14.5	11.7	1,480	7519272
	CAPT4961*4A*	G*E81005C*B*	45,500	32,200	14.5	11.7	1,570	7519273
	CAPT4961*4A*	G*EC961004CNA*	45,000	31,800	14.5	11.7	1,525	7519274
	CAPT4961*4A*	G*EC961205DNA*	45,000	31,800	14.5	12.0	1,525	7519275
	CAPT4961*4A*	G*VC80805C*B*	45,500	32,200	14.5	11.7	1,510	7519276
	CAPT4961*4A*	G*VC81005C*B*	45,500	32,200	14.5	11.7	1,530	7519277
	CAPT4961*4A*	G*VC960804CNA*	45,000	31,800	14.5	11.7	1,385	7519278
	CAPT4961*4A*	G*VC961005CNA*	45,500	32,200	14.5	11.7	1,450	7519279
	CAPT4961*4A*	G*VC961205DNA*	45,500	32,200	14.5	11.7	1,450	7519280
	CAPT4961*4A*	G*VM970804CNA*	45,000	31,800	14.5	11.7	1,385	7519281
	CAPT4961*4A*	G*VM971005CNA*	45,500	32,200	14.5	11.7	1,450	7519282
	CAPT4961*4A*	G*VM971205DNA*	45,500	32,200	14.5	11.7	1,450	7519283
	CAPT4961*4A*+EEP		46,000	32,600	14.0	11.7	1,550	7519261
	CAPT4961*4A*+MBVC2000**-1A*		45,000	31,800	14.5	11.7	1,595	7519284
	CHPF4860D6D*	A*VC960804CNA*	45,000	31,800	14.5	11.7	1,385	7519310
	CHPF4860D6D*	A*VC961005CNA*	45,500	32,200	14.5	11.7	1,450	7519311
	CHPF4860D6D*	A*VC961205DNA*	45,500	32,200	14.5	11.7	1,450	7519312
	CHPF4860D6D*	A*VM970804CNA*	45,000	31,800	14.5	11.7	1,385	7519313
	CHPF4860D6D*	A*VM971005CNA*	45,500	32,200	14.5	11.7	1,450	7519314
	CHPF4860D6D*	A*VM971205DNA*	45,500	32,200	14.5	11.7	1,450	7519315
	CHPF4860D6D*	G*VC960804CNA*	45,000	31,800	14.5	11.7	1,385	7519316
	CHPF4860D6D*	G*VC961005CNA*	45,500	32,200	14.5	11.7	1,450	7519317
	CHPF4860D6D*	G*VC961205DNA*	45,500	32,200	14.5	11.7	1,450	7519318
	CHPF4860D6D*	G*VM970804CNA*	45,000	31,800	14.5	11.7	1,385	7519319
	CHPF4860D6D*	G*VM971005CNA*	45,500	32,200	14.5	11.7	1,450	7519320
	CHPF4860D6D*	G*VM971205DNA*	45,500	32,200	14.5	11.7	1,450	7519321
	CHPF4860D6D*+EEP		46,000	32,600	14.0	11.7	1,550	7519285
	CHPF4860D6D*+EEP+TXV		46,000	32,600	14.0	11.7	1,550	7519286
	CHPF4860D6D*+MBVC2000**-1A*+TXV		46,000	32,600	14.5	12.0	1,600	7519287
	CHPF4860D6D*+TXV	A*EC961004CNA*	45,000	31,800	14.5	11.7	1,525	7519288
	CHPF4860D6D*+TXV	A*EC961205DNA*	45,000	31,800	14.5	12.0	1,525	7519289
	CHPF4860D6D*+TXV	A*VC80805C*B*	45,500	32,200	14.5	11.7	1,510	7519290
	CHPF4860D6D*+TXV	A*VC81005C*B*	45,500	32,200	14.5	11.7	1,530	7519291
	CHPF4860D6D*+TXV	A*VC960804CNA*	45,000	31,800	14.5	12.0	1,385	7519292
	CHPF4860D6D*+TXV	A*VC961005CNA*	45,500	32,200	14.5	12.0	1,450	7519293
	CHPF4860D6D*+TXV	A*VC961205DNA*	45,500	32,200	14.5	12.0	1,450	7519294
	CHPF4860D6D*+TXV	A*VM970804CNA*	45,000	31,800	14.5	12.0	1,385	7519295
	CHPF4860D6D*+TXV	A*VM971005CNA*	45,500	32,200	14.5	12.0	1,450	7519296
	CHPF4860D6D*+TXV	A*VM971205DNA*	45,500	32,200	14.5	12.0	1,450	7519297
	CHPF4860D6D*+TXV	G*E80805C*B*	45,000	31,800	14.5	11.7	1,480	7519298
	CHPF4860D6D*+TXV	G*E81005C*B*	45,500	32,200	14.5	11.7	1,570	7519299
	CHPF4860D6D*+TXV	G*EC961004CNA*	45,000	31,800	14.5	11.7	1,525	7519300
	CHPF4860D6D*+TXV	G*EC961205DNA*	45,000	31,800	14.5	12.0	1,525	7519301
	CHPF4860D6D*+TXV	G*VC80805C*B*	45,500	32,200	14.5	11.7	1,510	7519302
	CHPF4860D6D*+TXV	G*VC81005C*B*	45,500	32,200	14.5	11.7	1,530	7519303
	CHPF4860D6D*+TXV	G*VC960804CNA*	45,000	31,800	14.5	12.0	1,385	7519304
	CHPF4860D6D*+TXV	G*VC961005CNA*	45,500	32,200	14.5	12.0	1,450	7519305
	CHPF4860D6D*+TXV	G*VC961205DNA*	45,500	32,200	14.5	12.0	1,450	7519306
	CHPF4860D6D*+TXV	G*VM970804CNA*	45,000	31,800	14.5	12.0	1,385	7519307
	CHPF4860D6D*+TXV	G*VM971005CNA*	45,500	32,200	14.5	12.0	1,450	7519308
	CHPF4860D6D*+TXV	G*VM971205DNA*	45,500	32,200	14.5	12.0	1,450	7519309

See Notes on Page 69.

OUTDOOR UNIT	INDOOR UNITS		COOLING RATINGS				CFM	AHRI #
	COILS/AIR HANDLERS	FURNACES	TOTAL ¹	SENS. ¹	SEER ²	EER ³		
VSX14 0481A* (cont.)	CSCF4860N6D*	A*VC960804CNA*	45,000	31,800	14.5	11.7	1,385	7519342
	CSCF4860N6D*	A*VC961005CNA*	45,500	32,200	14.5	11.7	1,450	7519343
	CSCF4860N6D*	A*VC961205DNA*	45,500	32,200	14.5	11.7	1,450	7519344
	CSCF4860N6D*	A*VM970804CNA*	45,000	31,800	14.5	11.7	1,385	7519345
	CSCF4860N6D*	A*VM971005CNA*	45,500	32,200	14.5	11.7	1,450	7519346
	CSCF4860N6D*	A*VM971205DNA*	45,500	32,200	14.5	11.7	1,450	7519347
	CSCF4860N6D*	G*VC960804CNA*	45,000	31,800	14.5	11.7	1,385	7519348
	CSCF4860N6D*	G*VC961005CNA*	45,500	32,200	14.5	11.7	1,450	7519349
	CSCF4860N6D*	G*VC961205DNA*	45,500	32,200	14.5	11.7	1,450	7519350
	CSCF4860N6D*	G*VM970804CNA*	45,000	31,800	14.5	11.7	1,385	7519351
	CSCF4860N6D*	G*VM971005CNA*	45,500	32,200	14.5	11.7	1,450	7519352
	CSCF4860N6D*	G*VM971205DNA*	45,500	32,200	14.5	11.7	1,450	7519353
	CSCF4860N6D*+EEP		45,500	32,200	14.0	11.7	1,550	7519322
	CSCF4860N6D*+EEP+TXV		45,500	32,200	14.0	11.7	1,550	7519323
	CSCF4860N6D*+TXV	A*VC80805C*B*	45,500	32,200	14.5	11.7	1,510	7519324
	CSCF4860N6D*+TXV	A*VC81005C*B*	45,500	32,200	14.5	11.7	1,530	7519325
	CSCF4860N6D*+TXV	A*VC960804CNA*	45,000	31,800	14.5	12.0	1,385	7519326
	CSCF4860N6D*+TXV	A*VC961005CNA*	45,500	32,200	14.5	11.7	1,450	7519327
	CSCF4860N6D*+TXV	A*VC961205DNA*	45,500	32,200	14.5	11.7	1,450	7519328
	CSCF4860N6D*+TXV	A*VM970804CNA*	45,000	31,800	14.5	11.7	1,385	7519329
	CSCF4860N6D*+TXV	A*VM971005CNA*	45,500	32,200	14.5	11.7	1,450	7519330
	CSCF4860N6D*+TXV	A*VM971205DNA*	45,500	32,200	14.5	11.7	1,450	7519331
	CSCF4860N6D*+TXV	G*E80805C*B*	45,000	31,800	14.5	11.7	1,480	7519332
	CSCF4860N6D*+TXV	G*E81005C*B*	45,000	31,800	14.5	11.7	1,570	7519333
	CSCF4860N6D*+TXV	G*VC80805C*B*	45,500	32,200	14.5	11.7	1,510	7519334
	CSCF4860N6D*+TXV	G*VC81005C*B*	45,500	32,200	14.5	11.7	1,530	7519335
	CSCF4860N6D*+TXV	G*VC960804CNA*	45,000	31,800	14.5	12.0	1,385	7519336
	CSCF4860N6D*+TXV	G*VC961005CNA*	45,500	32,200	14.5	11.7	1,450	7519337
	CSCF4860N6D*+TXV	G*VC961205DNA*	45,500	32,200	14.5	11.7	1,450	7519338
	CSCF4860N6D*+TXV	G*VM970804CNA*	45,000	31,800	14.5	11.7	1,385	7519339
CSCF4860N6D*+TXV	G*VM971005CNA*	45,500	32,200	14.5	11.7	1,450	7519340	
CSCF4860N6D*+TXV	G*VM971205DNA*	45,500	32,200	14.5	11.7	1,450	7519341	
VSX14 0601A*	ASPT60D14A*		57,000	40,000	14.0	11.7	1,620	7519354
	ASPT61D14A*		57,000	40,000	14.0	11.7	1,645	7984221
	AVPTC60D14A*		57,000	40,000	14.0	11.7	1,620	7519355
	CA*F4961*6D*	A*VC961205DNA*	56,500	40,000	14.0	11.7	1,575	7519375
	CA*F4961*6D*	A*VM971205DNA*	56,500	40,000	14.0	11.7	1,575	7519376
	CA*F4961*6D*	G*VC961205DNA*	56,500	40,000	14.0	11.7	1,575	7519377
	CA*F4961*6D*	G*VM971205DNA*	56,500	40,000	14.0	11.7	1,575	7519378
	CA*F4961*6D*+EEP+TXV		57,000	40,000	14.0	11.7	1,545	7519356
	CA*F4961*6D*+MBVC2000*-1A*+TXV		57,000	40,000	14.5	12.0	1,620	7519357
	CA*F4961*6D*+TXV	A*EC961205DNA*	57,000	40,000	14.0	11.7	1,525	7519358
	CA*F4961*6D*+TXV	A*VC80805C*B*	57,000	40,000	14.5	11.7	1,560	7519359
	CA*F4961*6D*+TXV	A*VC81005C*B*	57,000	40,000	14.5	11.7	1,525	7519360
	CA*F4961*6D*+TXV	A*VC961005CNA*	57,000	40,000	14.0	11.7	1,525	7519361
	CA*F4961*6D*+TXV	A*VC961205DNA*	57,000	40,000	14.5	12.0	1,575	7519362
	CA*F4961*6D*+TXV	A*VM971005CNA*	57,000	40,000	14.0	11.7	1,525	7519363
	CA*F4961*6D*+TXV	A*VM971205DNA*	57,000	40,000	14.5	12.0	1,575	7519364
	CA*F4961*6D*+TXV	G*E80805C*B*	57,000	40,000	14.5	11.7	1,525	7519365
	CA*F4961*6D*+TXV	G*E80805D*A*	57,000	40,000	14.5	12.0	1,500	7519366
	CA*F4961*6D*+TXV	G*E81005C*B*	57,000	40,000	14.5	11.7	1,600	7519367
	CA*F4961*6D*+TXV	G*EC961205DNA*	57,000	40,000	14.0	11.7	1,525	7519368
CA*F4961*6D*+TXV	G*VC80805C*B*	57,000	40,000	14.5	11.7	1,560	7519369	

See Notes on Page 69.

OUTDOOR UNIT	INDOOR UNITS		COOLING RATINGS				CFM	AHRI #
	COILS/AIR HANDLERS	FURNACES	TOTAL ¹	SENS. ¹	SEER ²	EER ³		
VSX14 0601A* (cont.)	CA*F4961*6D*+TXV	G*VC81005C*B*	57,000	40,000	14.5	11.7	1,525	7519370
	CA*F4961*6D*+TXV	G*VC961005CNA*	57,000	40,000	14.0	11.7	1,525	7519371
	CA*F4961*6D*+TXV	G*VC961205DNA*	57,000	40,000	14.5	12.0	1,575	7519372
	CA*F4961*6D*+TXV	G*VM971005CNA*	57,000	40,000	14.0	11.7	1,525	7519373
	CA*F4961*6D*+TXV	G*VM971205DNA*	57,000	40,000	14.5	12.0	1,575	7519374
	CAPT4961*4A*	A*VC80805C*B*	57,000	40,000	14.0	11.7	1,560	7519380
	CAPT4961*4A*	A*VC81005C*B*	57,000	40,000	14.0	11.7	1,525	7519381
	CAPT4961*4A*	G*E80805C*B*	57,000	40,000	14.0	11.7	1,525	7519382
	CAPT4961*4A*	G*E80805D*A*	57,000	40,000	14.0	12.0	1,500	7519383
	CAPT4961*4A*	G*E81005C*B*	57,000	40,000	14.0	11.7	1,600	7519384
	CAPT4961*4A*	G*VC80805C*B*	57,000	40,000	14.0	11.7	1,560	7519385
	CAPT4961*4A*	G*VC81005C*B*	57,000	40,000	14.0	11.7	1,525	7519386
	CAPT4961*4A*	A*EC961205DNA*	56,500	40,000	14.0	11.7	1,525	7519387
	CAPT4961*4A*	A*VC961005CNA*	57,000	40,000	14.0	11.7	1,525	7519388
	CAPT4961*4A*	A*VC961205DNA*	56,500	40,000	14.0	11.7	1,575	7519389
	CAPT4961*4A*	A*VM971005CNA*	57,000	40,000	14.0	11.7	1,525	7519390
	CAPT4961*4A*	A*VM971205DNA*	56,500	40,000	14.0	11.7	1,575	7519391
	CAPT4961*4A*	G*EC961205DNA*	56,500	40,000	14.0	11.7	1,525	7519392
	CAPT4961*4A*	G*VC961005CNA*	57,000	40,000	14.0	11.7	1,525	7519393
	CAPT4961*4A*	G*VC961205DNA*	56,500	40,000	14.0	11.7	1,575	7519394
	CAPT4961*4A*	G*VM971005CNA*	57,000	40,000	14.0	11.7	1,525	7519395
	CAPT4961*4A*	G*VM971205DNA*	56,500	40,000	14.0	11.7	1,575	7519396
	CAPT4961*4A*+EEP		57,000	40,000	14.0	11.7	1,545	7519379
	CHPF4860D6D*	A*VC961205DNA*	56,500	40,000	14.0	11.7	1,575	7519416
	CHPF4860D6D*	A*VM971205DNA*	56,500	40,000	14.0	11.7	1,575	7519417
	CHPF4860D6D*	G*VC961205DNA*	56,500	40,000	14.0	11.7	1,575	7519418
	CHPF4860D6D*	G*VM971205DNA*	56,500	40,000	14.0	11.7	1,575	7519419
	CHPF4860D6D*+EEP+TXV		57,000	40,000	14.0	11.7	1,545	7519397
	CHPF4860D6D*+MBVC2000**~1A*+TXV		57,000	40,000	14.5	12.0	1,620	7519398
	CHPF4860D6D*+TXV	A*EC961205DNA*	57,000	40,000	14.0	11.7	1,525	7519399
	CHPF4860D6D*+TXV	A*VC80805C*B*	57,000	40,000	14.5	11.7	1,560	7519400
	CHPF4860D6D*+TXV	A*VC81005C*B*	57,000	40,000	14.5	11.7	1,525	7519401
	CHPF4860D6D*+TXV	A*VC961005CNA*	57,000	40,000	14.0	11.7	1,525	7519402
	CHPF4860D6D*+TXV	A*VC961205DNA*	57,000	40,000	14.5	12.0	1,575	7519403
	CHPF4860D6D*+TXV	A*VM971005CNA*	57,000	40,000	14.0	11.7	1,525	7519404
	CHPF4860D6D*+TXV	A*VM971205DNA*	57,000	40,000	14.5	12.0	1,575	7519405
	CHPF4860D6D*+TXV	G*E80805C*B*	57,000	40,000	14.5	11.7	1,525	7519406
	CHPF4860D6D*+TXV	G*E80805D*A*	57,000	40,000	14.5	12.0	1,500	7519407
	CHPF4860D6D*+TXV	G*E81005C*B*	57,000	40,000	14.5	11.7	1,600	7519408
	CHPF4860D6D*+TXV	G*EC961205DNA*	57,000	40,000	14.0	11.7	1,525	7519409
	CHPF4860D6D*+TXV	G*VC80805C*B*	57,000	40,000	14.5	11.7	1,560	7519410
	CHPF4860D6D*+TXV	G*VC81005C*B*	57,000	40,000	14.5	11.7	1,525	7519411
	CHPF4860D6D*+TXV	G*VC961005CNA*	57,000	40,000	14.0	11.7	1,525	7519412
	CHPF4860D6D*+TXV	G*VC961205DNA*	57,000	40,000	14.5	12.0	1,575	7519413
	CHPF4860D6D*+TXV	G*VM971005CNA*	57,000	40,000	14.0	11.7	1,525	7519414
CHPF4860D6D*+TXV	G*VM971205DNA*	57,000	40,000	14.5	12.0	1,575	7519415	
CSCF4860N6D*	A*VC961205DNA*	56,500	40,000	14.0	11.7	1,575	7519439	

See Notes on Page 69.

OUTDOOR UNIT	INDOOR UNITS		COOLING RATINGS				CFM	AHRI #
	COILS/AIR HANDLERS	FURNACES	TOTAL ¹	SENS. ¹	SEER ²	EER ³		
VSX14 0601A* (cont.)	CSCF4860N6D*	A*VM971205DNA*	56,500	40,000	14.0	11.7	1,575	7519440
	CSCF4860N6D*	G*VC961205DNA*	56,500	40,000	14.0	11.7	1,575	7519441
	CSCF4860N6D*	G*VM971205DNA*	56,500	40,000	14.0	11.7	1,575	7519442
	CSCF4860N6D*+EEP+TXV		57,000	40,000	14.0	11.7	1,545	7519420
	CSCF4860N6D*+MBVC2000**-.1A*+TXV		57,000	40,000	14.5	12.0	1,620	7519421
	CSCF4860N6D*+TXV	A*EC961205DNA*	57,000	40,000	14.0	11.7	1,525	7519422
	CSCF4860N6D*+TXV	A*VC80805C*B*	57,000	40,000	14.5	11.7	1,560	7519423
	CSCF4860N6D*+TXV	A*VC81005C*B*	57,000	40,000	14.5	11.7	1,525	7519424
	CSCF4860N6D*+TXV	A*VC961005CNA*	57,000	40,000	14.0	11.7	1,525	7519425
	CSCF4860N6D*+TXV	A*VC961205DNA*	57,000	40,000	14.5	12.0	1,575	7519426
	CSCF4860N6D*+TXV	A*VM971005CNA*	57,000	40,000	14.0	11.7	1,525	7519427
	CSCF4860N6D*+TXV	A*VM971205DNA*	57,000	40,000	14.5	12.0	1,575	7519428
	CSCF4860N6D*+TXV	G*E80805C*B*	57,000	40,000	14.5	11.7	1,525	7519429
	CSCF4860N6D*+TXV	G*E80805D*A*	57,000	40,000	14.5	12.0	1,500	7519430
	CSCF4860N6D*+TXV	G*E81005C*B*	57,000	40,000	14.5	11.7	1,600	7519431
	CSCF4860N6D*+TXV	G*EC961205DNA*	57,000	40,000	14.0	11.7	1,525	7519432
	CSCF4860N6D*+TXV	G*VC80805C*B*	57,000	40,000	14.5	11.7	1,560	7519433
	CSCF4860N6D*+TXV	G*VC81005C*B*	57,000	40,000	14.5	11.7	1,525	7519434
	CSCF4860N6D*+TXV	G*VC961005CNA*	57,000	40,000	14.0	11.7	1,525	7519435
	CSCF4860N6D*+TXV	G*VC961205DNA*	57,000	40,000	14.5	12.0	1,575	7519436
CSCF4860N6D*+TXV	G*VM971005CNA*	57,000	40,000	14.0	11.7	1,525	7519437	
CSCF4860N6D*+TXV	G*VM971205DNA*	57,000	40,000	14.5	12.0	1,575	7519438	

¹ BTU/h

² Seasonal Energy Efficiency Ratio; Certified per AHRI 210/240 @ 80°F/ 67°F/ 95°F

³ Energy Efficiency Ratio @ 80°F/ 67°F/ 95°F

Notes

Always check the S&R plate for electrical data on the unit being installed.

When matching the outdoor unit to the indoor unit, use the piston supplied with the outdoor unit or that specified on the piston kit chart supplied with the indoor unit.

EEP - Order from Service Dept. Part No. B13707-38 or new Solid State Board B13707-35S. Part No. B13707-38 is not interchangeable with B13707-35S.

The GMC brand gas furnace contains the EEP cooling time delay.

DIMENSIONS

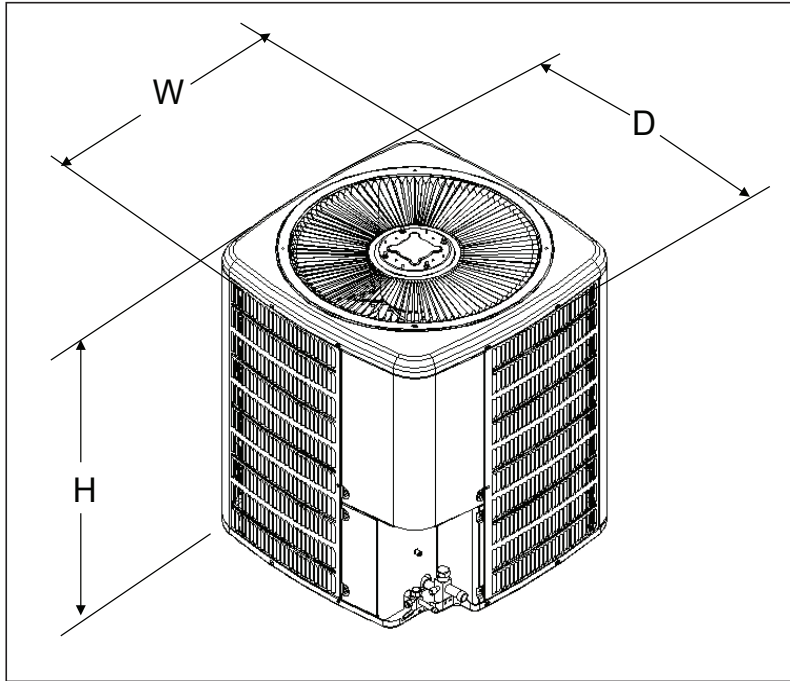

MODEL	DIMENSIONS		
	W"	D"	H"
VSX140181**	26	26	27½
VSX140191**	26	26	27½
VSX140241**	26	26	27½
VSX140251**	26	26	27½
VSX140301**	29	29	32½
VSX140311**	29	29	32½
VSX140361**	29	29	32½
VSX140371**	29	29	32½
VSX140421**	29	29	36¼
VSX140431**	29	29	36¼
VSX140481**	35½	35½	36¼
VSX140601**	35½	35½	38¼

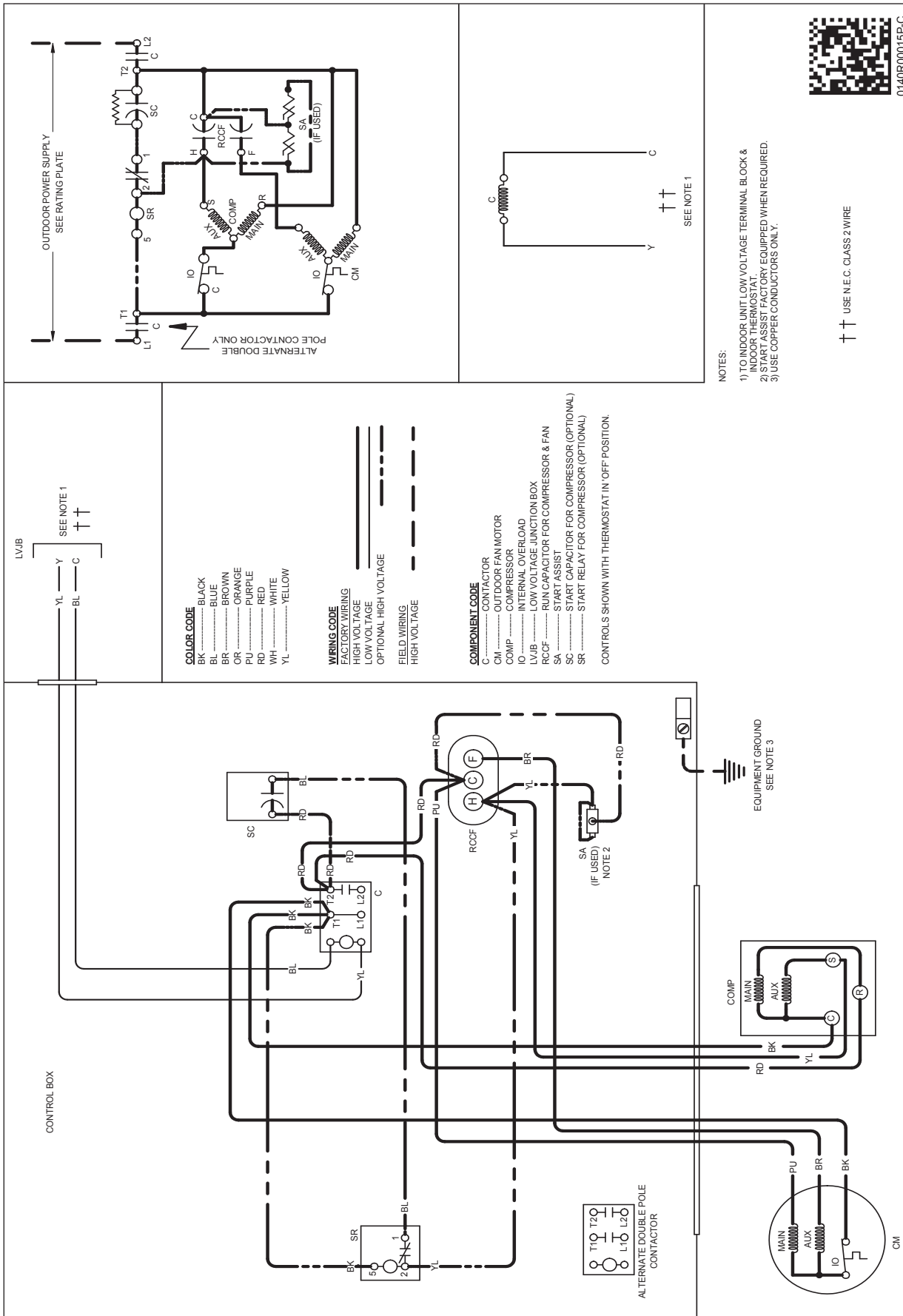

MODEL #	DESCRIPTION	VSX14 018/19	VSX14 024/25	VSX14 030/31	VSX14 036/37	VSX14 042/43	VSX14 048	VSX14 060
ABK-20	Anchor Bracket Kit [Ⓜ]			X	X	X	X	X
ABK-21	Anchor Bracket Kit [Ⓜ]	X	X					
ASC-01	Anti-Short Cycle Kit	X	X	X	X	X	X	X
CSR-U-1	Hard-start Kit	X	X	X	X			
CSR-U-2	Hard-start Kit					X	X	X
CSR-U-3	Hard-start Kit						X	X
FSK01A ¹	Freeze Protection Kit	X	X	X	X	X	X	X
LSK02A ²	Liquid Line Solenoid Kit	X	X	X	X	X	X	X
TX2N4 ²	TXV Kit	X						
TX2N4A ²	TXV Kit	X	X					
TX3N4 ²	TXV Kit			X	X			
TX5N4 ²	TXV Kit					X	X	X

[Ⓜ] Contains 20 brackets; four brackets needed to anchor unit to pad

¹ Installed on indoor coil

² Field-installed, non-bleed, expansion valve kit — Condensing units and heat pumps with reciprocating compressors require the use of start-assist components when used in conjunction with an indoor coil using a non-bleed thermal expansion valve refrigerant metering device or liquid line solenoid kit. The TXV should always be sized based on the tonnage of the outdoor unit.