

Air-Cooled Split System Condensing Units

Models RCS 06F – 20F
6.5 to 20 Tons
R-410A Refrigerant



6.5 – 7.5 Tons



10.0 – 12.0 Tons



15.0 – 20.0 Tons

Table of Contents

Introduction	3	Maintenance and Operation	20
Hazard Identification Information	3	Charging Charts	21
Checking Product Received	3	Wiring Diagrams	27
Standard Unit Features	4	Service and Warranty Procedure	29
Dimensional and Weight Data	6	Replacement Parts	29
Physical Data	8	In-Warranty Return Material Procedure	29
Unit Capacity and Physical Data	8	Warranty Registration Form	30
Electrical Data	9	Quality Assurance Survey Form	32
Power Wiring	9		
Installation	10		
Order Parts	10		
Standard Items	10		
Crankcase Heaters	10		
Corrosive Environment	10		
Installation General	10		
Rooftop Installation	11		
Slab Installation	11		
Installation of Piping	12		
Typical Piping Recommendations	12		
Electrical Wiring	14		
Refrigerant Charge	16		
Evaporator Coil	17		
Evacuation and Charging	17		
Final Leak Testing	18		
Accessory Installation	19		

Hazard Identification Information

DANGER

The use of unauthorized components, accessories or devices may adversely affect the operation of the condensing unit and may also endanger life and property.

The manufacturer disclaims any responsibility for such loss or injury and the manufacturer's warranty does not cover any damage or defect to the air conditioner caused by the attachment or use of any components, accessories or devices (other than those authorized by the manufacturer) into, onto or in conjunction with the condensing unit.

DANGER

Dangers indicate a hazardous situation which will result in death or serious injury if not avoided.

WARNING

Warnings indicate potentially hazardous situations, which can result in property damage, severe personal injury, or death if not avoided.

CAUTION

Cautions indicate potentially hazardous situations, which can result in personal injury or equipment damage if not avoided.

This manual contains the installation and operating instructions for your split condensing unit. There are a few precautions that should be taken to derive maximum satisfaction from it. Improper installation can result in unsatisfactory operation or dangerous conditions.

Read this manual and any instructions packaged with separate equipment required to make up the system prior to installation. Give this manual to the owner and explain its provisions. The owner should retain this manual for future reference.

Checking Product Received

Upon receiving the unit, inspect it for any damage from shipment. Claims for damage, either shipping or concealed, should be filed immediately with the shipping company. Check the unit model number, electrical characteristics, and accessories to determine if they are correct.

Nomenclature

R C S - 06 - F - 078 - C

Rooftop Condensing System

Nominal capacity (tons)

06 = 6.5

07 = 7.5

10 = 10 (single compressor)

11 = 10 (tandem compressors)

12 = 12

15 = 15

20 = 20

Refrigerant

F = R-410A

Voltage

C = 208/230 - 3 - 60

D = 460 - 3 - 60

Y = 575 - 3 - 60

Compressor

078 = 6.5 ton, single

090 = 7.5 ton, single

120 = 10 ton, single

125 = 10 ton, tandem

150 = 12.5 ton, tandem

180 = 15 ton, tandem

240 = 20 ton, tandem

NOTE: For larger size units (greater than 20 ton), refer to Catalog 222.

Introduction

Standard Unit Features

Cabinet — Galvanized steel with a durable powder paint finish. Stamped louvered panels offer 100% protection for the condenser coil.

Compressor — Hermetically sealed scroll compressors. Compressors are mounted on rubber-in-shear pads to reduce vibration and noise.

Condenser Coil — Constructed with copper tubes and aluminum fins mechanically bonded to the tubes for maximum heat transfer capabilities. All coil assemblies are leak tested at 450 psig internal pressure.

Refrigerant Connections — Field piping connections are made through a fixed panel. This allows complete access or removal of access panels after piping connections have been made.

Crankcase Heater — Standard, all models.

Low Ambient Control — A pressure sensitive fan cycling control to allow unit operation to 0°F is standard.

Service Valves — Standard on liquid lines and vapor lines.

Service Access — The control box, as well as the compressor and other refrigerant controls, is accessible through access panels. It may be opened without affecting the normal operation of the unit. Condenser fan motors are accessible by removing wire grilles.

Filter Drier — Field supplied.

Sight Glass — Optional, field supplied.

Transformer — Step down type, line to 24 volts.

Contactor — The contactor is an electrical switch which operates the compressor and condenser fans.

High Pressure Control — Opens the contactor circuit on high refrigerant pressure; manual reset.

Low Pressure Control — Stops compressor operation in the event of loss of refrigerant.

Condenser Fan Motor (Direct Drive) — Ball bearing 1075 RPM motors are mounted to minimize vibration and noise problems. These are permanent split capacitor types and require the same capacitance for both run and start.

Testing — All units are run tested at the factory prior to shipment. Units are shipped with a holding pressure of nitrogen.

Figure 1: RCS 06F & 07F Ton Features

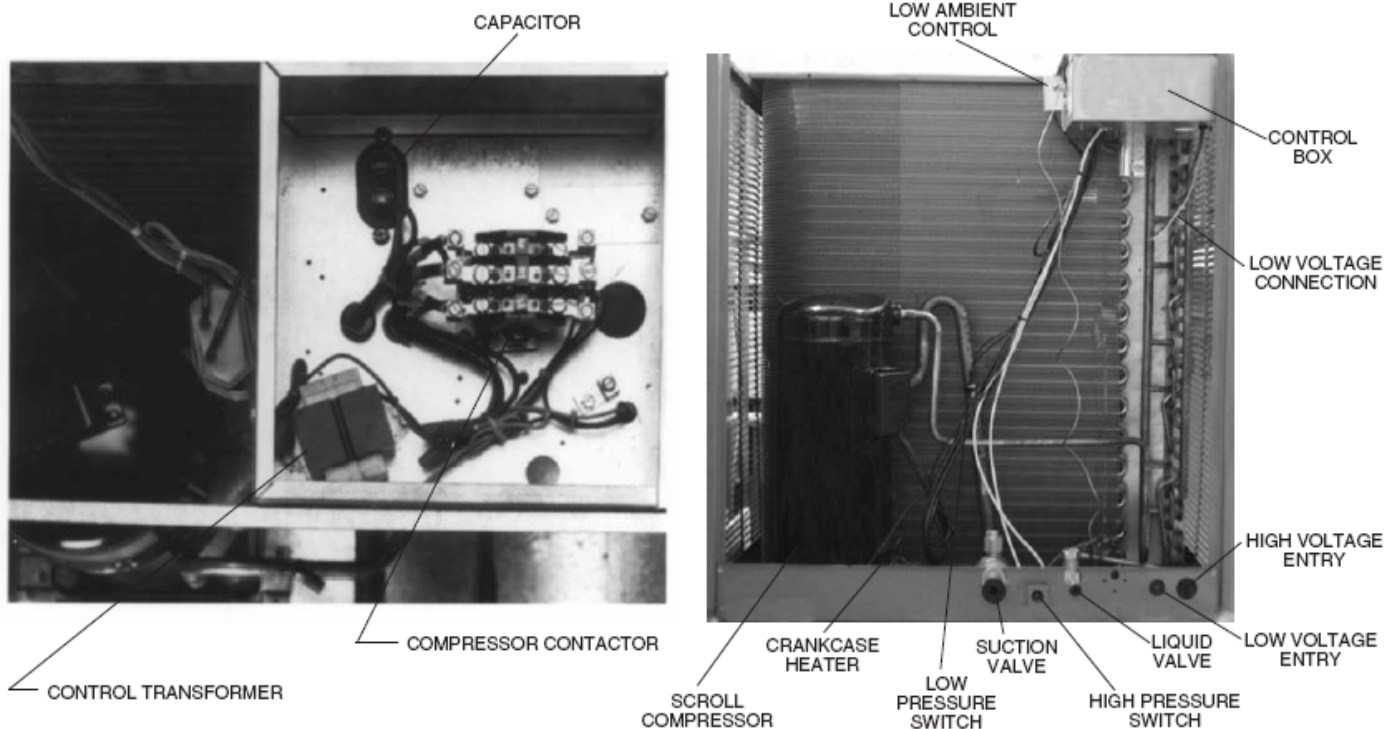
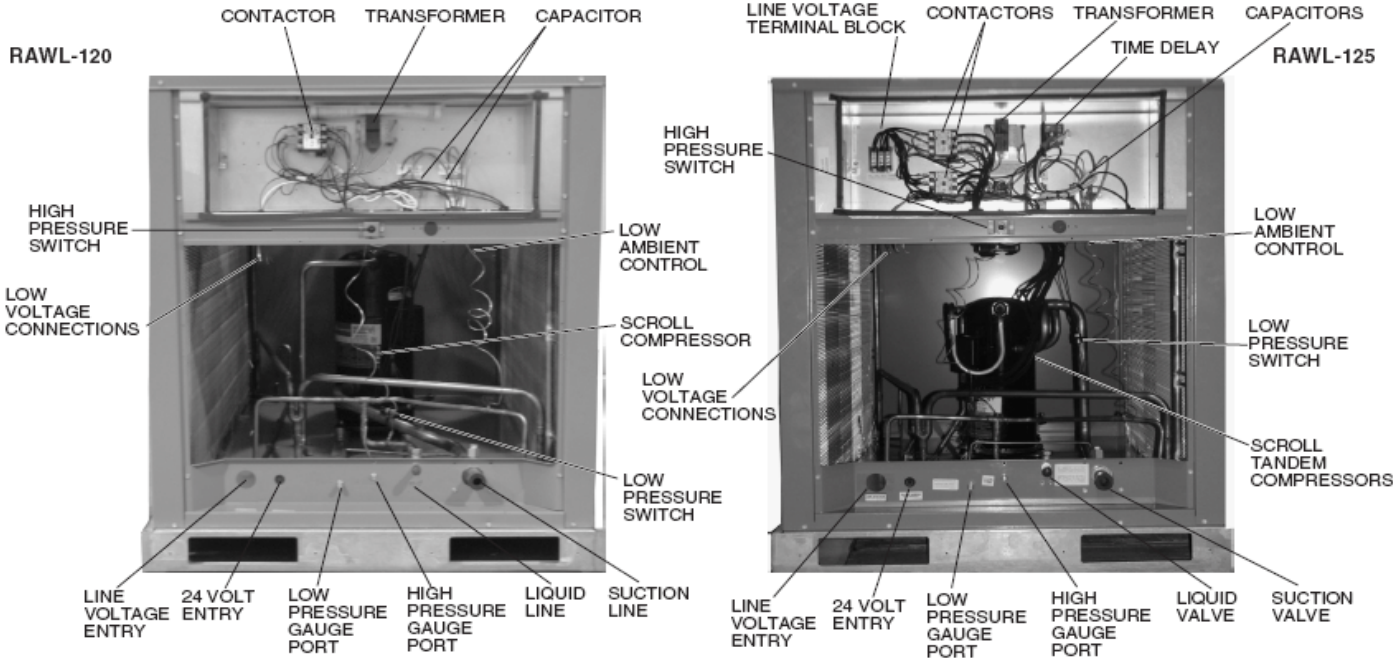

Figure 2: RCS 10F – 20F Ton Features



Dimensional and Weight Data

Figure 3: RCS 06F and 07F Dimensions and Weights

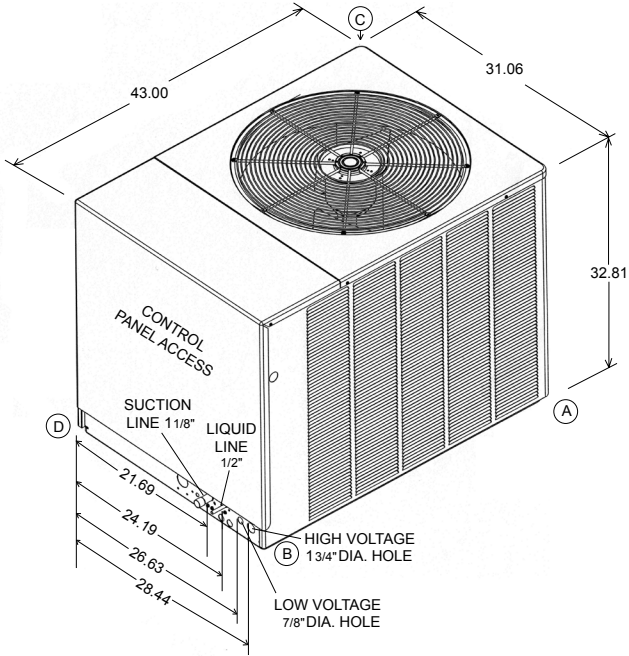

Table 1: RCS 06F and 07F Operating Weights

RCS model	Total weight lbs. [kg]	Corner weight lbs. [kg]			
		A	B	C	D
06F	291 [132]	50 [22.7]	73 [33.1]	69 [31.3]	99 [44.9]
07F	318 [144]	53 [24.0]	84 [38.1]	71 [32.2]	110 [49.9]

Figure 4: RCS 10F and 11F Dimensions and Weights

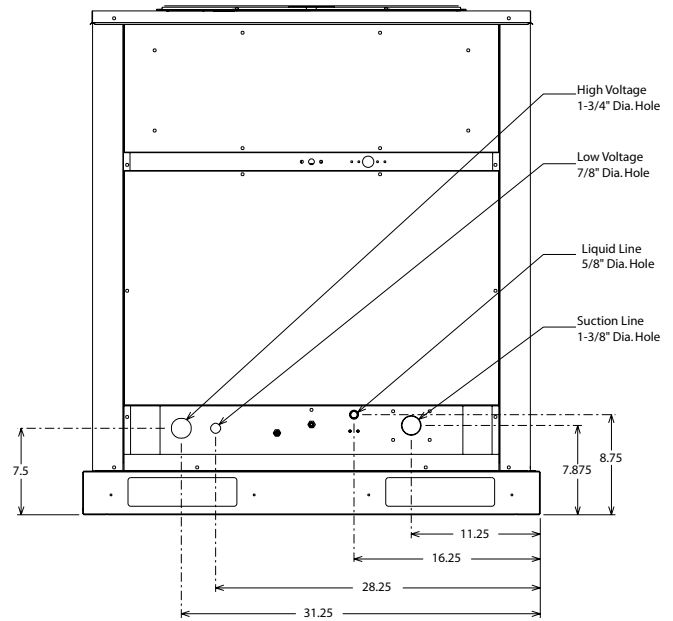
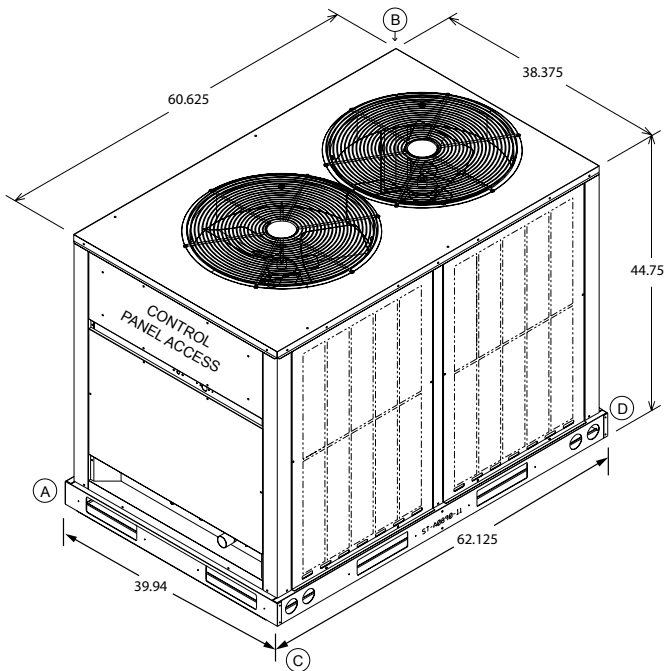

Table 2: RCS 10F and 11F Operating Weights

RCS model	Total weight lbs. [kg]	Corner weight lbs. [kg]			
		A	B	C	D
10F (Single)	501 [228]	123 [53.9]	132 [60.0]	119 [54.1]	127 [58.0]
11F (Tandem)	586 [266]	144 [65.3]	154 [69.9]	139 [63.2]	149 [67.6]

Dimensional and Weight Data

Figure 5: RCS 12F Dimensions and Weights

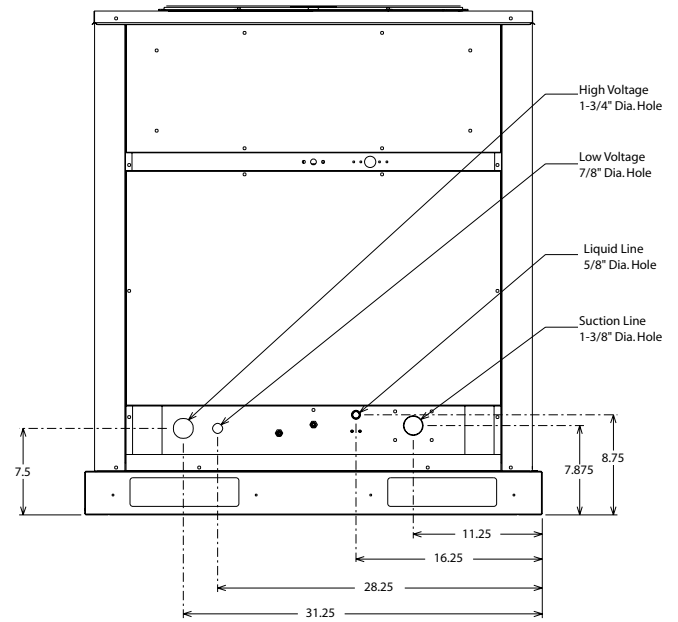
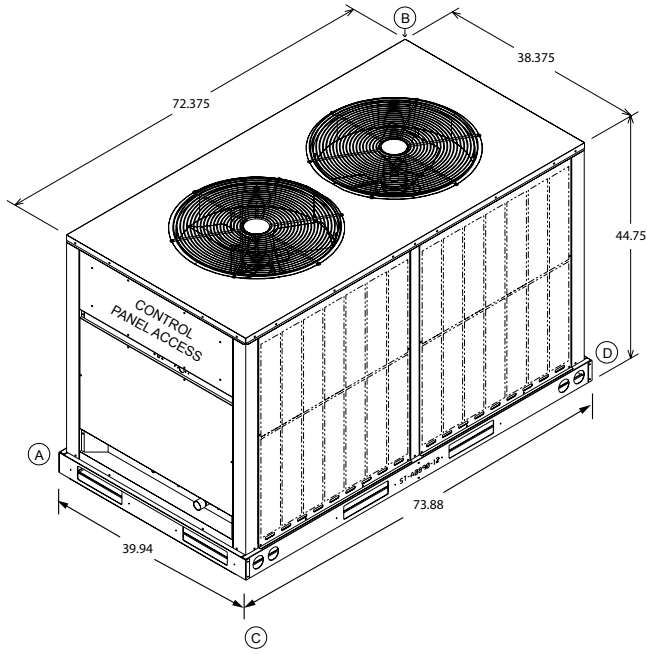

Table 3: RCS 12F Operating Weights

RCS model	Total weight lbs. [kg]	Corner weight lbs. [kg]			
		A	B	C	D
12F	650 [293]	160 [72.0]	171 [78.0]	154 [70.0]	165 [75.0]

Figure 6: RCS 15F – 20F Dimensions and Weights

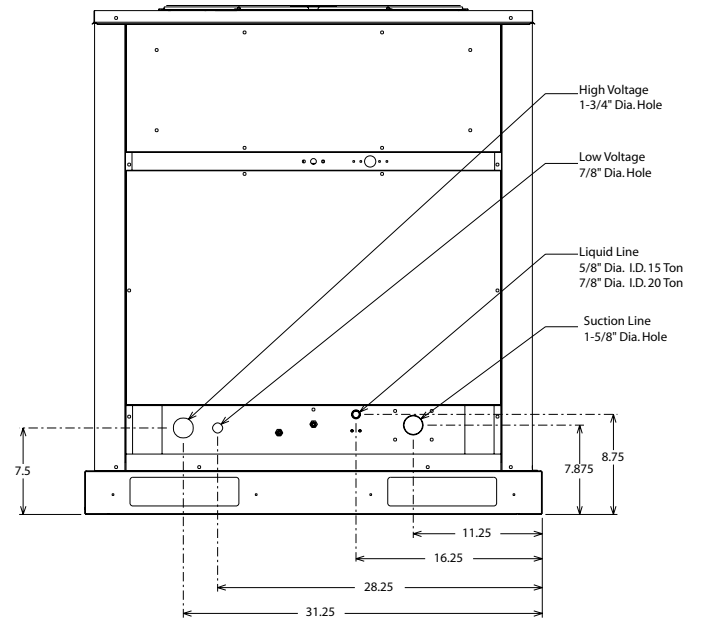
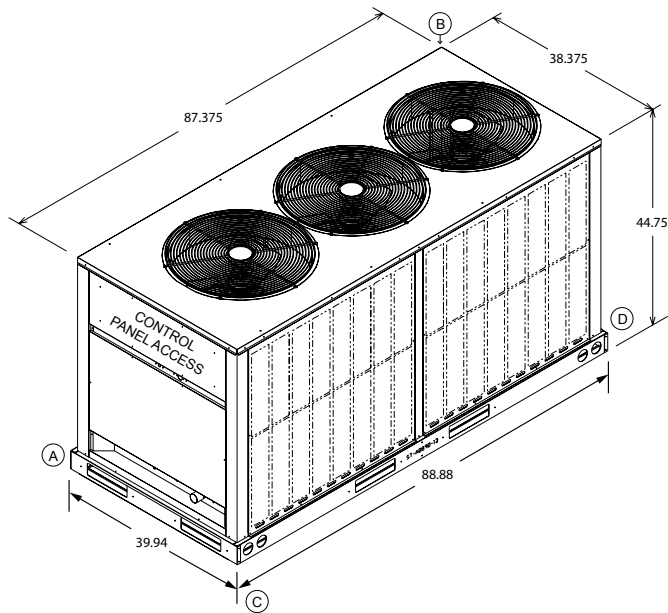

Table 4: RCS 15F and 20F Operating Weights

RCS model	Total weight lbs. [kg]	Corner weight lbs. [kg]			
		A	B	C	D
15F	746 [338.0]	183 [83.0]	196 [89.0]	177 [80.0]	189 [86.0]
20F	952 [432.0]	234 [106.0]	251 [114.0]	226 [103.0]	241 [110.0]

Physical Data

Unit Capacity and Physical Data

Table 5: RCS 06F – 20F Physical Data

Model	RCS						
	06F Single	07F Single	10F Single	11F Tandem	12F Tandem	15F Tandem	20F Tandem
Capacity and Weight							
Capacity (tons) [kW]	6.5 [22.9]	7.5 [26.4]	10 [35.2]	10 [35.2]	12 [42.2]	15 [52.8]	20 [70.3]
Number of circuits	1						
Operating weight (lbs) [Kg]	291 [132]	318 [144]	501 [227.3]	586 [265.8]	650 [294.8]	746 [338.4]	952 [431.8]
Shipping weight (lbs) [Kg]	314 [142.5]	341 [154.7]	541 [245.4]	626 [284.0]	690 [313.0]	786 [356.5]	992 [450.0]
Compressor							
Quantity	1			2			
Type	Scroll						
RPM	3500						
Refrigerant charge R410A oz. [g]	178 [5046]	242 [6861]	339 [9661]	300 [8505]	378 [10,716]	506 [14,345]	655 [18,569]
Condenser Fans							
Quantity	1		2			3	
CFM [L/s]	4700 [2218]	4700 [2218]	8100 [3822]	8100 [3822]	8100 [3882]	12,000 [5663]	12,000 [5663]
Diameter (in.) [mm]	24 [610]	24 [610]	24 [610]	24 [610]	24 [610]	24 [610]	24 [610]
Drive	Direct						
Motor horsepower each [W]	1/3 [249]	1/3 [249]	1/3 [249]	1/3 [249]	1/3 [249]	1/3 [249]	1/3 [249]
Type	PSC						
RPM	1075						
Condenser Coil							
Quantity	1		2				3
Rows	1-1/2			2			3
Fins per inch	20	22	18	22	22	22	22
Sq. ft. [m ²]	23.0 [2.14]	23.0 [2.14]	27.0 [2.51]	27.0 [2.51]	33.9 [3.05]	40.38 [3.75]	40.38 [3.75]
Fins/tubes	Aluminum/Copper						
Cabinet							
Finish	Powder Coat						
Sheet metal	Galvanized						
Gauge (nominal) top	20						
Sides	20						
Base rails	14						
Refrigerant Connection							
Vapor sweat (in.) [mm]	1-1/8 [29]	1-1/8 [29]	1-3/8 [35]	1-3/8 [35]	1-3/8 [35]	1-5/8 [41.3]	1-5/8 [41.3]
Liquid sweat (in.) [mm]	1/2 [13]	1/2 [13]	5/8 [16]	5/8 [16]	5/8 [16]	5/8 [16]	7/8 [22]

Power Wiring

Table 6: RCS 06F – 20F Electrical Data

Model	RCS																				
	06F			07F			10F			11F			12F			15F			20F		
Compressor Motor																					
Voltage	208/230	460-	575	208/230	460	575	208/230	460	575	208/230	460	575	208/230	460	575	208/230	460	575	208/230	460	575
Phase and hertz																			3-60		
Number of compressors	Single									Tandem											
Operating Current																					
Rated load amps (each) ¹	22.4	10.6	7.7	25.0	12.2	9.0	30.1	16.7	12.2	17.6	9.6	6.1	22.4	10.6	7.7	25.0	12.2	9.0	33.3	17.9	12.8
Locked rotor amps (each) ¹	149	75	54	164	100	78	225	114	80	123	64	40	14	75	54	164	100	78	239	125	80
Condenser Fan Motors																					
Voltage	208/230	460	575	208/230	460	575	208/230	460	575	208/230	460	575	208/230	460	575	208/230	460	575	208/230	460	575
Phase	Single																				
Full load amps (each)	2.2	1.3	1.0	2.2	1.3	1.0	2.4	1.4	1.0	2.4	1.4	1.0	2.4	1.4	1.0	2.4	1.4	1.0	2.4	1.1	0.8
System characteristics																					
Unit full load amps ²	24.6	11.9	8.7	27.2	13.5	10.0	34.9	19.5	14.2	40.0	22.0	14.2	49.6	24.0	17.4	57.2	28.6	21.0	73.8	39.1	28.0
Minimum circuit ampacity	31.0	15.0	11.0	34.0	17.0	13.0	43.0	24.0	18.0	45.0	25.0	16.0	56.0	27.0	20.0	64.0	32.0	24.0	83.0	44.0	32.0
Maximum fuse size (amps) or HACR circuit breaker ampacity ³	50	25	15	50	25	20	60	40	25	60	30	20	70	35	25	80	40	30	110	60	40
Disconnect size	60	30	30	60	30	30	60	40	25	60	30	30	60	30	30	100	60	60	200	60	60

Note:

- 1 Each compressor
- 2 Conditions at 45° suction and 95° ambient
- 3 Local codes take precedent over recommended fuse size

Figure 7: Control Box Example – RCS 10F Through 20F

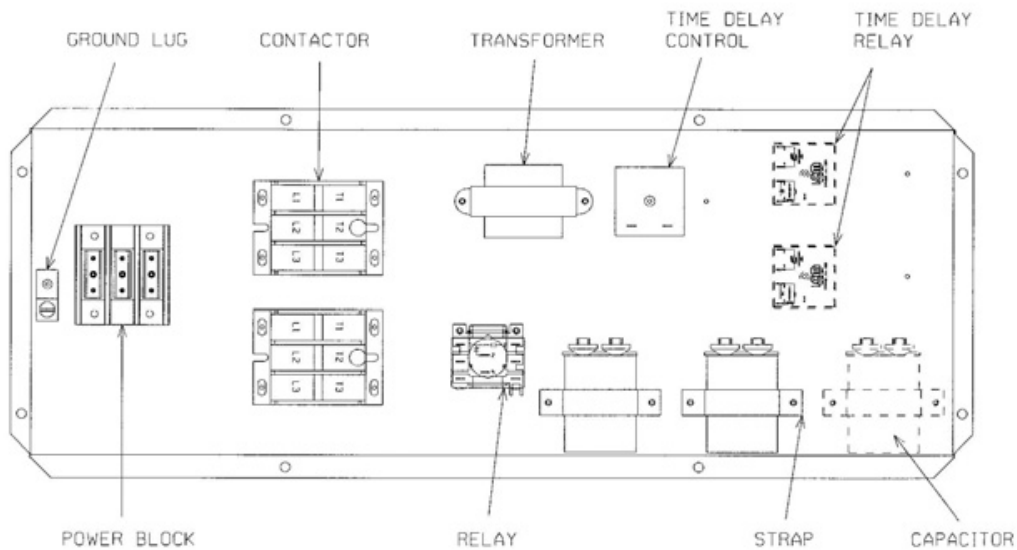

Installation

Order Parts

When reporting shortages or damaged parts, or when ordering repair parts, give the complete unit model and serial numbers which are stamped on the unit rating plate.

Standard Items

The condensing unit consists of a completely assembled package which includes a compressor pack, condenser coils, fans, fan motors, outdoor control box, factory wiring, factory tubing and fittings.

Crankcase Heaters

These units are equipped with a crankcase heater that is factory wired to operate whenever the main power supply to the unit is "ON" and compressors are "OFF." Before starting the equipment after prolonged shutdown or at the time of initial spring startup, be sure that the circuits to the condensing units are closed for at least 24 hours.

Corrosive Environment

The metal parts of this unit may be subject to rust or deterioration if exposed to a corrosive environment. This oxidation could shorten the equipment's useful life. Corrosive elements include salt spray, fog or mist in seacoast areas, sulphur or chlorine from lawn watering systems, and various chemical contaminants from industries such as paper mills and petroleum refineries.

If the unit is to be installed in an area where contaminants are likely to be a problem, special attention should be given to the equipment location and exposure.

- Avoid having lawn sprinkler heads spray directly on the unit cabinet
- In coastal areas, locate the unit on the side of the building away from the waterfront.
- Shielding provided by a protection, based on clearances

DANGER

Disconnect all power to unit before starting maintenance. Failure to do so can cause electrical shock resulting in severe personal injury or death.

Regular maintenance will reduce the buildup of contaminants and help to protect the unit's finish.

- Frequent washing of the cabinet, fan blade and coil with fresh water will remove most of the salt or other contaminants that build up on the unit.
- Regular cleaning and waxing of the cabinet with a good automobile polish will provide some protection.
- A good liquid cleaner may be used several times a year to remove matter that will not wash off with water.

Several different types of protective coatings are offered in some areas. These coatings may provide some benefit, but the effectiveness of such coating materials cannot be verified by the equipment manufacturer.

Installation General

The condensing unit should be installed outdoors. It should be located as near as possible to the evaporator section to keep connecting refrigerant tubing lengths to a minimum. The unit must be installed to allow a free air flow to the condenser coils

If several units are installed adjacent to each other, take care to avoid recirculation of air from one condenser to another. In all installations, adequate space must be provided for installation and servicing.

The unit must not be connected to any duct work. Do not locate unit under a roof drip; if necessary, install gutters, etc., to prevent water runoff onto the unit. To prevent air recirculation, it is recommended that the unit not be installed under an overhang. However, if this is necessary, allow a minimum of 60" above the unit for air discharge

Figure 8: Clearances RCS 06F – 20F Service Clearances

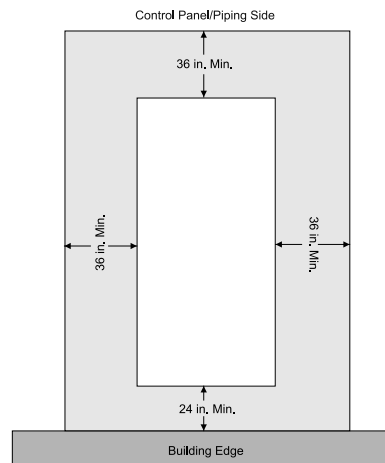

Rooftop Installation

If rooftop installation is required, make certain that the building construction is adequate for the weight of the unit. (Table 5) Before placing the unit on the roof, make certain that the nylon rigging slings are of sufficient length to maintain equilibrium of the unit when lifting. Under no circumstances should the unit be lifted by only one corner for rooftop installation.

Slab Installation

Condensing units should be set on a solid level foundation. When installed at ground level, the unit should be placed on a 6" cement slab. If the pad is formed at the installation site, do not pour the pad tight against the structure, otherwise vibration will be transmitted from the unit through the pad.

Table 7: RCS 06F and 07F Operating Weights

RCS model	Total weight lbs. [kg]	Corner weight lbs. [kg]			
		A	B	C	D
06F	291 [132]	50 [22.7]	73 [33.1]	69 [31.3]	99 [44.9]
07F	318 [144]	53 [24.0]	84 [38.1]	71 [32.2]	110 [49.9]
10F (Single)	501 [228]	123 [53.9]	132 [60.0]	119 [54.1]	127 [58.0]
11F (Tandem)	586 [266]	144 [65.3]	154 [69.9]	139 [63.2]	149 [67.6]
12F	650 [293]	160 [72.0]	171 [78.0]	154 [70.0]	165 [75.0]
15F	746 [338.0]	183 [83.0]	196 [89.0]	177 [80.0]	189 [86.0]
20F	952 [432.0]	234 [106.0]	251 [114.0]	226 [103.0]	241 [110.0]

Figure 9: Rigging

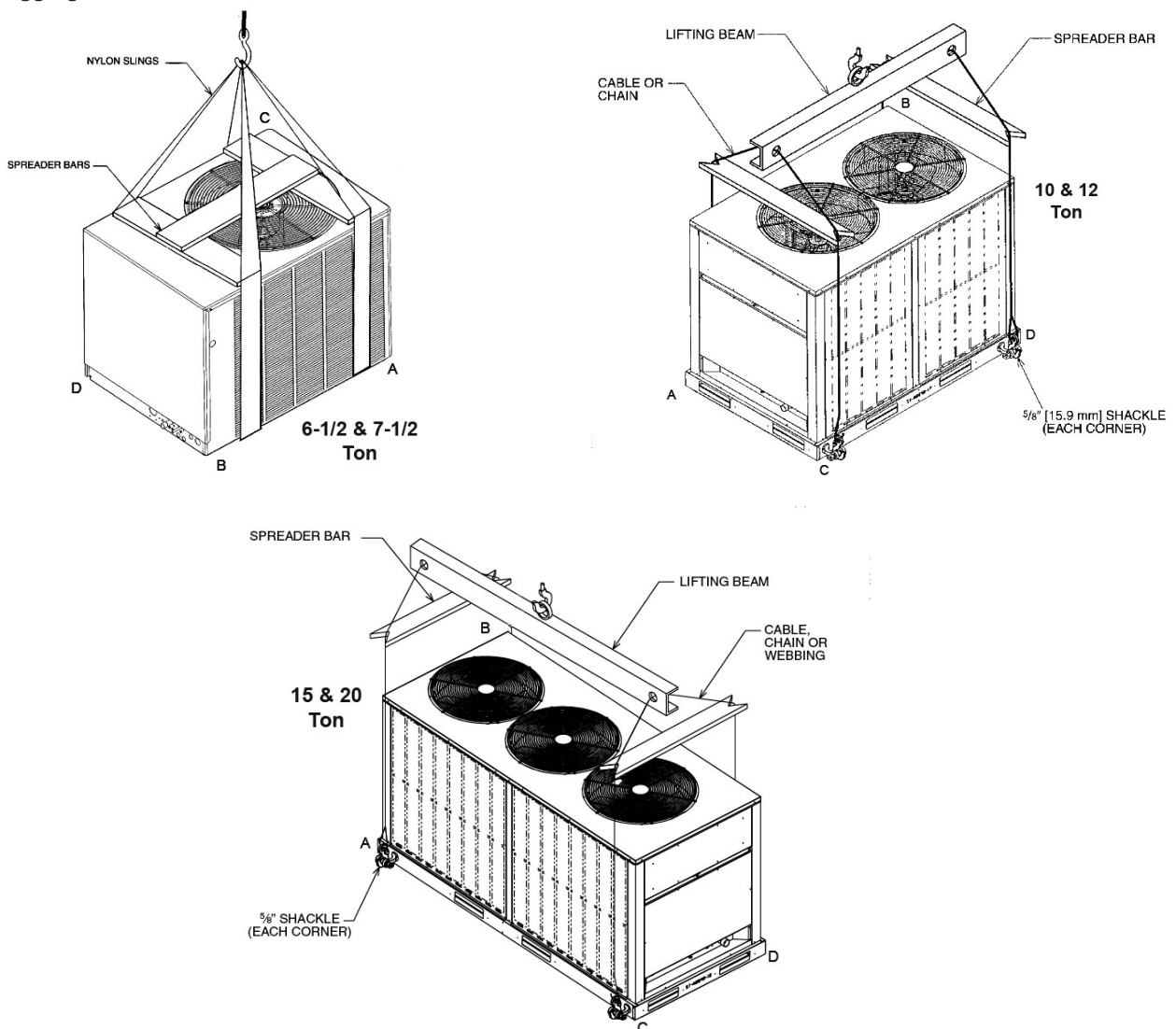

Installation

Installation of Piping

WARNING

Do not use oxygen to purge lines or pressure system for leak test. Oxygen reacts violently with oil, which can cause an explosion resulting in severe personal injury or death.

NOTE: The condensing unit is shipped with a holding charge of dry nitrogen which must be purged from the unit before evacuation.

Once located, the condensing unit is ready to be interconnected with the evaporator using ONLY refrigeration grade dehydrated tubing. The following should be considered when connecting the tubing.

1. Pitch vapor line toward the compressor approximately 1/2" every 10 feet to facilitate oil return.
2. It is recommended that the sight glass, filter drier and liquid line solenoid valve be installed in the liquid line just prior to the evaporator.
3. Silver solder (such as silfos, Easy Flow, etc.) should be used for all refrigerant joints.
4. Thoroughly clean all joints before fluxing. DO NOT USE ACID FLUX.
5. When fluxing, limit the application of paste to the minimum and always apply flux to the male portion of the connection.
6. Vapor lines should be insulated to prevent condensate drip. Use insulation of at least 3/8" wall thickness. The insulation should be installed on the tubing prior to making the sweat connections.
7. Insulate the liquid line whenever the heat pickup or transfer can affect the subcooling.
8. Care should be taken to avoid transmission of noise or vibration to building structure.

Typical Piping Recommendations

The following will be of help in accomplishing a successful

1. Size liquid line for no more than 10°F loss which corresponds to approximately 3 psig pressure drop.
2. Size vapor lines for no more than 2°F loss which corresponds to approximately 3 psig pressure drop.
3. Install sight glass, filter drier and solenoid valve in liquid line adjacent to evaporator. Filter drier should be between the condensing unit and sight glass.
4. Pitch all horizontal vapor lines downward in the direction of flow (1/2" to 10 ft. run).
5. When making up refrigerant piping, take every precaution to prevent dirt and moisture from entering the piping.
6. Locate the condensing unit and evaporator(s) as close together as possible to minimize piping runs.
7. Liquid or vapor lifts not to exceed 60 ft.
8. To prevent suction line breakage due to vibration and to prevent tubing noise transmission into the conditioned space, the suction clamp must be installed after tubing is brazed as illustrated in [Figure 10](#).

Figure 10: Suction Clamp

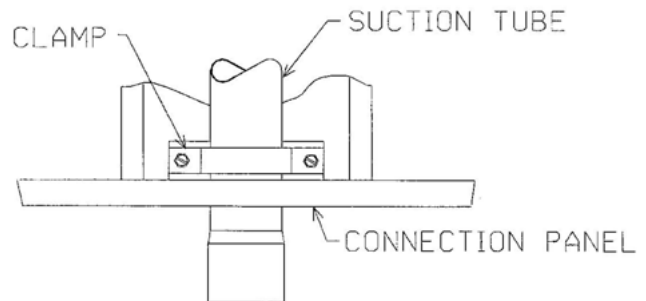

Table 8: Refrigerant Piping Data

Equivalent Length, ft. [m] of Straight Type "L" Tubing for Nonferrous Valves/Fittings (Brazed)						
Tube Size, O.D.	Solenoid Valve	Angle Valve	Short Radius El	Long Radius El	Tee Line Flow	Tee Branch Flow
1/2	70 [21.3]	8.3 [2.5]	1.6 [0.5]	1.0 [0.3]	1.0 [0.3]	3.1 [0.9]
5/8	72 [21.9]	10.4 [3.2]	1.9 [0.6]	1.2 [0.4]	1.2 [0.4]	3.6 [1.1]
3/4	75 [22.9]	12.5 [3.8]	2.1 [0.7]	1.4 [0.4]	1.4 [0.4]	4.2 [1.3]
7/8	78 [23.8]	14.6 [4.4]	2.4 [0.7]	1.6 [0.5]	1.6 [0.5]	4.8 [1.5]
1-1/8	—	18.8 [5.7]	3.0 [0.9]	2.0 [0.6]	2.0 [0.6]	6.0 [1.8]
1-3/8	—	22.9 [7.0]	3.6 [1.1]	2.4 [0.7]	2.4 [0.7]	7.2 [2.2]
1-5/8	—	27.1 [8.3]	4.2 [1.3]	2.8 [0.8]	2.8 [0.8]	8.4 [2.6]
2-1/8	—	35.4 [10.8]	5.3 [1.6]	3.5 [1.1]	10.7 [3.3]	10.7 [3.3]

Table 9: Recommended Vapor and Liquid Line Sizes for Various Lengths of Run

Recommended Vapor and Liquid Line Sizes for Various Lengths of Run														
Equivalent Length to Evaporator (ft)	Cooling Model													
	Liquid Line O.D. Sizes (in)							Vapor Line O.D. Sizes (in)						
	6	7	10	11	12	15	20	6	7	10	11	12	15	20
0 to 15	1/2	1/2	5/8	5/8	5/8	5/8	7/8	1-1/8	1-1/8	1-3/8	1-3/8	1-3/8	1-5/8	1-5/8
16 to 50	1/2	1/2	5/8	5/8	5/8	5/8	7/8	1-1/8	1-1/8	1-3/8	1-3/8	1-5/8	1-5/8	1-5/8
51 to 100	1/2	1/2	5/8	5/8	5/8	3/4	7/8	1-1/8	1-3/8	1-3/8	1-3/8	1-5/8	1-5/8	2-1/8
101 to 150	1/2	1/2	5/8	5/8	5/8	3/4	7/8	1-3/8	1-3/8	1-5/8	1-5/8	2-1/8	2-1/8	2-1/8

NOTE: Line length between condenser and evaporator (suction and liquid) not to exceed 150' equivalent length.

Figure 11: Liquid Line Pressure Drop Per 100 Feet Equivalent Length (Type L Copper Tubing)

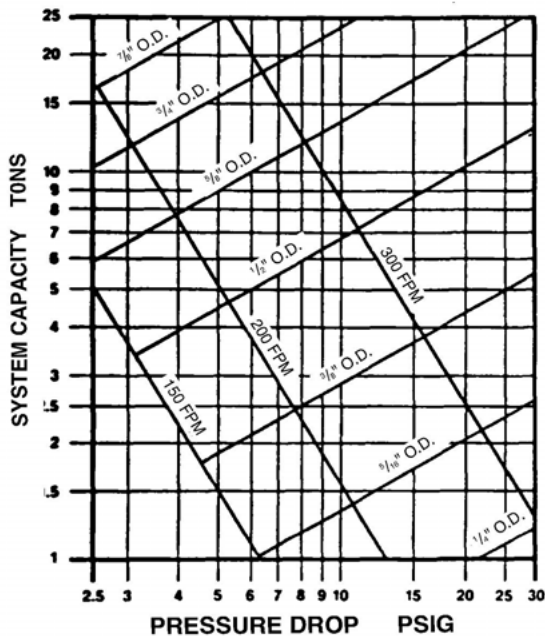

Note:

1. When evaporator coil is above condenser, the pressure drop due to vertical lift (0.5 PSIG per foot of lift) must be added to the pressure drop derived from this curve.
2. Size liquid line for no more than 10°F loss (approximately 30 PSIG total pressure drop).
3. Do not oversize liquid line. Oversized liquid lines add significantly to the amount of refrigerant required to charge the system.
4. The maximum recommended velocity with solenoid valves or other quick closing devices in the liquid line is 300 FPM.

Figure 12: Suction Line System Capacity Loss In Percent Per 100 Feet Equivalent Length (Type L Copper Tubing)

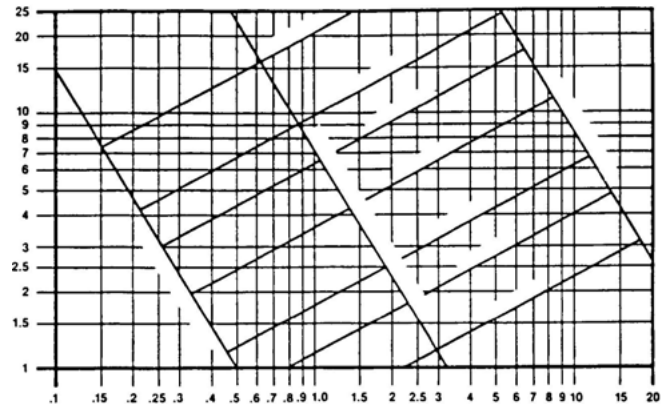

Note:

1. The minimum velocity line (700 fpm) is recommended for cooling only units with vertical or horizontal run refrigerant lines.
2. For suction pressure drop (PSIG), multiply percent (%) loss by 1.18.

Figure 13: Typical Drain Piping

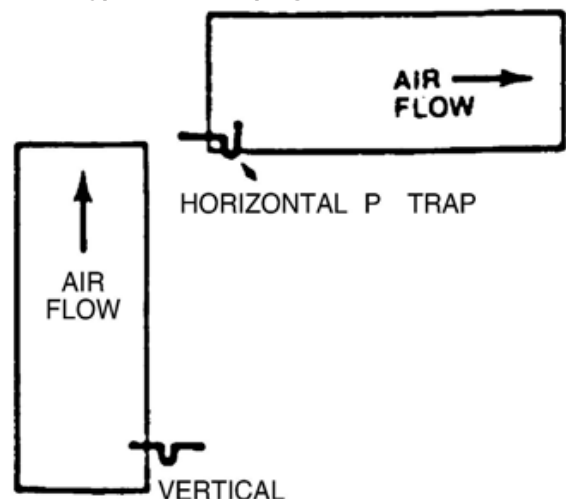

Installation

Figure 14: Coil Above Condensing Unit

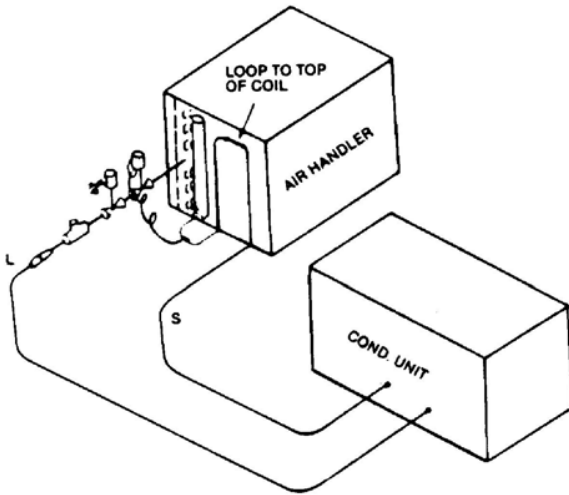
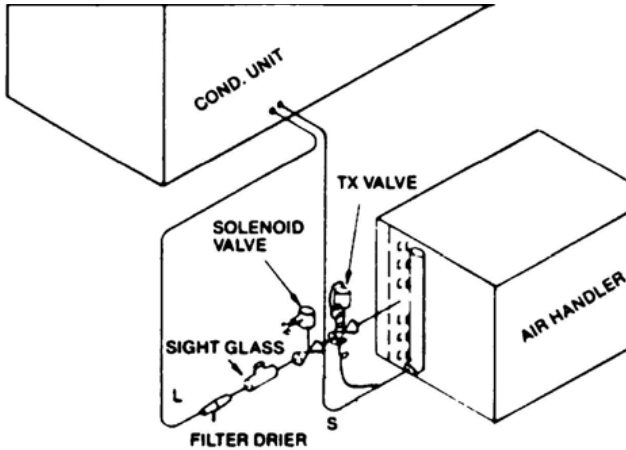

Figure 15: Coil Below Condensing Unit



NOTE: PIPING ACCESSORIES SHOWN SHOULD BE MOUNTED AS CLOSE TO AIR HANDLER AS POSSIBLE.

Electrical Wiring

NOTE: Field wiring must comply with the National Electric Code (NEC in the U.S., CEC in Canada) and any local ordinance that may apply.

Electrical Power

It is important that proper electrical power is available at the unit. Voltage must not vary more than 10% from that stamped on the rating plate. (See [Table 6 on page 9](#) for minimum and maximum voltage.) Interphase voltage variation on three-phase units must not be more than 3%. Contact local power company for correction of improper voltage or phase unbalance.

Important: Models equipped with scroll compressors must be phased correctly for proper compressor rotation. If the compressor is noisy or if suction and discharge pressures do not appear normal, reverse any two power leads to the unit. Extended run time in reverse rotation will damage the compressor and lead to premature failure.

Power Wiring

Power wiring should be run in grounded rain-tight conduit. See [Table 6](#) for wire ampacity and proper wire size.

Wire Routing

POWER WIRING MUST BE RUN IN CONDUIT. Conduit must be run through the connector panel below the service cover and attached to the bottom of the control box.

If low (extra-low in Canada) voltage control wire is run in conduit with power supply, Class I insulation is required. If run separate, Class II is required. Low voltage wiring may be run through the insulated bushing provided in the 7/8" hole in the connector panel, then route to the control box.

WARNING

After completing wiring, check all electrical connections, including factory wiring within the unit. Make sure all connections are tight. Replace and secure all electrical box covers and access doors before leaving the unit or turning on power to the unit. Failure to do so can cause a fire or electrical shock resulting in property damage, personal injury or death.

Table 10: Field Wire Size for 24 Volt Thermostat

Thermostat Load Amps	Solid Copper Wire –AWG				
	16	12	10	10	10
3.0	16	12	10	10	10
2.5	16	12	12	10	10
2.0	18	14	12	12	10
Length of Run, ft ⁽¹⁾	50	150	200	250	300

(1) Wire length equals twice the run distance.

Grounding

A grounding lug is provided in control box for a ground wire. Grounding also may be accomplished by grounding the power line conduit to the unit.

WARNING

This unit must be permanently grounded. A ground lug is provided near the contactor for a ground wire. Failure to do so can cause a fire or electrical shock resulting in property damage, severe personal injury or death.

Thermostat

An appropriate thermostat should be mounted on an inside wall in a location where it will not be affected by the sun or drafts, from open doors or other sources. Install, level, and after installation check the thermostat calibration and recalibrate if necessary. Refer to thermostat manufacturer's information for additional installation, checkout and operation instructions.

Table 11: Copper Wire Size (1% Voltage Drop)

Circuit Ampacity	Copper Wire Gauge (75°C Insulation)				
	Distance In Feet				
	100	150	200	250	300
40	6	4	3	2	1
45	4	3	2	1	1/0
50	4	3	2	1	1/0
60	4	2	1	1/0	2/0
70	3	2	1/0	2/0	3/0
80	3	1	1/0	2/0	3/0
90	2	1/0	2/0	3/0	4/0
100	2	1/0	2/0	3/0	4/0
110	1	2/0	3/0	4/0	250
125	1	2/0	3/0	4/0	250

Figure 16: Typical Field Wiring Connections

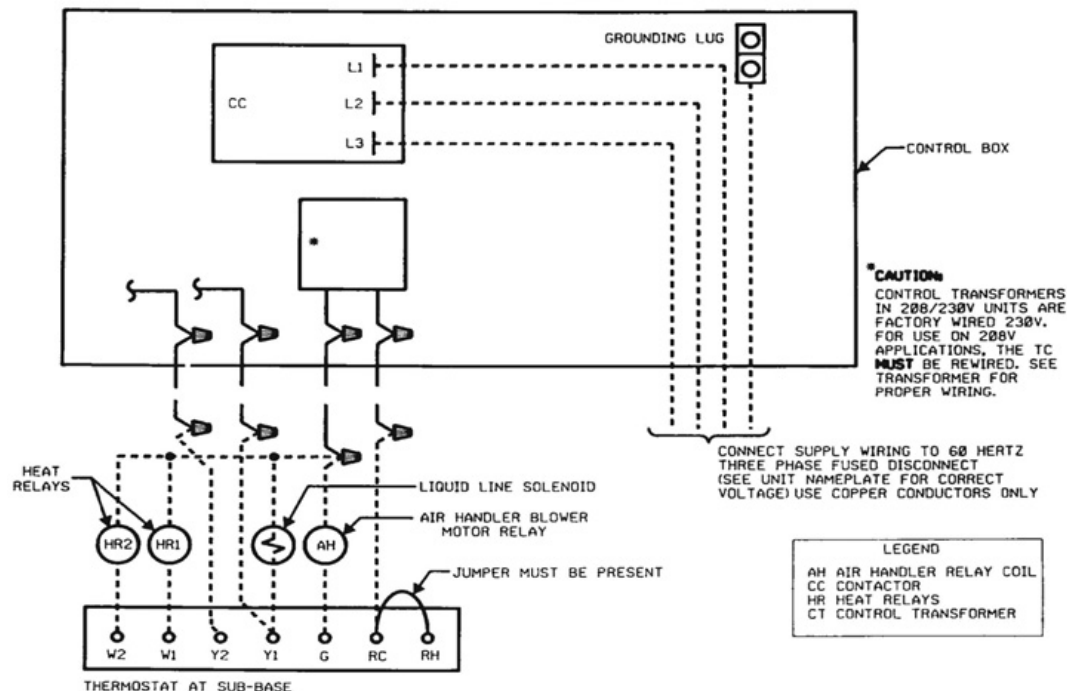

Installation

Refrigerant Charge

Leak Testing

Pressurize line set and coil through service fittings with dry nitrogen to 150 psig maximum. Leak test all joints using liquid detergent. If a leak is found, recover pressure and repair.

WARNING

Do not use oxygen to purge lines or pressure system for leak test. Oxygen reacts violently with oil, which can cause an explosion resulting in severe personal injury or death.

Table 12: Basic System Charge*

Unit	Charge oz [g]
06F	178 [5046]
07F	242 [6861]
10F	339 [9661]
11F	300 [8505]
12F	378 [10,716]
15F	506 [14,345]
20F	655 [18,569]

Note: *System with 0 Feet of Tubing

Table 13: Required Ounces of R410A Charge per Foot of Tubing

Tube Size O.D., in [mm]	Liquid Tube, oz [g]	Vapor, oz [g]
1/2 [12.7]	1.06 [30.0]	0.04 [1.13]
5/8 [15.88]	1.65 [46.7]	0.07 [1.98]
3/4 [19.05]	2.46 [69.7]	0.10 [2.83]
7/8 [22.23]	3.28 [92.9]	0.13 [3.68]
1-1/8 [28.58]	—	0.22 [6.23]
1-3/8 [34.93]	—	0.34 [9.63]
1-5/8 [41.28]	—	0.48 [13.60]
2-1/8 [53.98]	—	0.84 [23.81]

Note: Quantities based on 110°F liquid and 45°F vapor

Tools Required for Installing and Servicing R410A Models

Manifold Sets:

- Up to 800 PSIG High side
- Up to 250 PSIG Low Side
- 550 PSIG Low Side Retard

Manifold Hoses:

- Service Pressure Rating of 800 PSIG

Recovery Cylinders:

- 400 PSIG Pressure Rating
- Dept. of Transportation 4BA400 or BW400

CAUTION

R410A systems operate at higher pressures than R22 systems. Do not use R22 service equipment or components on R410A equipment

Specification of R410A

Application: R410A is not a drop-in replacement for R22; equipment designs must accommodate its higher pressures. It cannot be retrofitted into R22 condensing units.

Physical Properties: R410A has an atmospheric boiling point of 62.9°F and its saturation pressure at 77°F is 224.5 psig.

Composition: R410A is an azeotropic mixture of 50% by weight difluoromethane (HFC32) and 50% by weight pentafluoroethane (HFC125).

Pressure: The pressure of R410A is approximately 60% (1.6 times) greater than R22. Recovery and recycle equipment, pumps, hoses and the like need to have design pressure ratings appropriate for R410A. Manifold sets need to range up to 800 psig high-side and 250 psig low-side with a 550 psig low-side retard. Hoses need to have a service pressure rating of 800 psig. Recovery cylinders need to have a 400 psig service pressure rating. DOT 4BA400 or BW400.

Combustibility: At pressures above 1 atmosphere, mixture of R410A and air can become combustible. R410A and air should never be mixed in tanks or supply lines, or be allowed to accumulate in storage tanks. Leak checking should never be done with a mixture of R410A and air. Leak checking can be performed safely with nitrogen or a mixture of FR410A and nitrogen.

Quick Reference Guide for R410A

- R410A refrigerant operates at approximately 60% higher pressure (1.6 times) than R22. Ensure that servicing equipment is designed to operate with R410A.
- R410A refrigerant cycles are pink in color.
- R410A, as with other HFC's is only compatible with POE oils.
- Vacuum pumps will not remove moisture from oil.
- R410A systems are to be charged with liquid refrigerants. Prior to March 1999, R410A refrigerant cylinders had a dip tube. These cylinders should be kept upright for equipment charging. Post March 1999 cylinders do not have a dip tube and should be inverted to ensure liquid charging of the equipment.
- Do not install a suction line filter drier in the liquid line.
- A liquid line filter drier is standard on every unit. Only manufacturer approved liquid line filter driers can be used. These filter driers are rated for minimum working pressure of 600 psig.
- Desiccant (drying agent) must be compatible for POE oils and R410A.

Replacement Units

To prevent failure of a new condensing unit, the existing evaporator tubing system must be correctly sized and cleaned or replaced. Care must be exercised that the expansion device is not plugged. For new and replacement units, a liquid line filter drier should be installed and refrigerant tubing should be properly sized. Test the oil for acid. If positive, a suction line filter drier is mandatory.

Important: When replacing an R22 unit with an R410A unit, either replace the line set or ensure that the existing line set is thoroughly cleaned of any old oil or debris.

Evaporator Coil

Refer to evaporator coil manufacturer's installation instructions.

Important: The manufacturer is not responsible for the performance and operation of a mismatched system, or for a match listed with another manufacturer's coil.

CAUTION

Only use evaporators approved for use on R410A systems. Use of existing R22 evaporators can introduce mineral oil to the R410A refrigerant forming two different liquids and decreasing oil return to the compressor. This can result in compressor failure.

Evacuation and Charging

The evacuation of any system component that has been exposed to atmosphere or lost its charge is essential before charging. Never attempt to operate a system while it is under a vacuum.

NOTE: The condensing unit is shipped with a holding charge of dry nitrogen which must be purged from the unit before evacuation.

1. Since the condensing unit itself must be evacuated, open the vapor, discharge and liquid shut-off valves.
2. Use a refrigeration type vacuum pump capable of evacuation in the 500 micron range.
3. Connect the vacuum pump to the service manifold assembly with a pressure gauge that will read 30 inches vacuum. Connect the service manifold to the vapor line service port. ("Low" shown on label.)
4. With an accurate scale, 1/2 oz., set refrigerant tank up so its weight can be measured while in a position to charge liquid. (Unit must be OFF.) Energize liquid line solenoid valve by wiring valve to 24V power supply (or open by manual stem if applicable).
5. Connect to the liquid line service port. ("High" shown on label.) Shut off tank and evacuate the system. The pressure gauge should read at least 29.5" of vacuum.
6. Triple evacuate the system.
7. The refrigerant system will now be free of noncondensables.
8. Remove vacuum pump from 3-way valve.
9. Install refrigerant tank (liquid charging) to liquid line service valve.
10. Before tightening, purge tank and service valve hose.
11. Note weight of refrigerant tank.
12. De-energize liquid line solenoid valve. Open refrigerant tank valve. Allow pressure in tank and unit to equalize.
13. Close off service valve to liquid line service port and note weight of refrigerant tank.
14. Position tank for gas charging.
15. Rewire liquid line solenoid to thermostat control. Close main disconnect switch and turn thermostat to lowest setting.
16. Charge unit per [Table 12](#) and [Table 13](#).

Installation

17. Adjust refrigerant charge to obtain pressures indicated in the temperature/pressure [Charging Charts starting on page 21](#).
18. Note weight of refrigerant tank.
19. When system has stabilized, check superheat at the suction line service valve. The actual line temperature should be 8° to 20°F higher than the saturation temperature corresponding to the vapor pressure. If superheat is measured at evaporator, the actual line temperature should be 6° to 10° higher than the saturation temperature corresponding to the vapor pressure.
20. Close service ports on vapor and liquid valves. Remove service gauges.
21. Replace service port caps and valve stem caps. These caps must be replaced to prevent leaks.
22. Record total charge quantity on rating plate.

Final Leak Testing

After the unit has been properly evacuated and charged, a halogen leak detector should be used to detect leaks in the system. All piping within the condensing unit, evaporator, and interconnecting tubing should be checked for leaks. If a leak is detected, the refrigerant should be recovered before repairing a the leak. The Clean Air Act prohibits releasing refrigerant into the atmosphere.

Table 14: Charging Hints

Symptom	Possible Cause	Remedy
High head pressure	Air flow to/from condenser restricted or dirty condenser	Remove obstruction, relocate condensing unit, if necessary clean condenser
	Faulty condenser fan or motor	Replace
	Overcharge of refrigerant	Reduce charge
	Air in system	Evacuate and recharge
Low head pressure	Short of refrigerant	Check for leak, add charge
	Low evaporator air flow	Increase blower speed, check filters
Low vapor & hot compressor	Short of refrigerant	Check for leak—add refrigerant
Excessive sweating	Low indoor airflow	Increase speed of air handler blower or reduce restriction, replace air filter
	Excess refrigerant	Slowly reduce charge

Table 15: Pre-Start Check

1	Is the condensing unit properly located and level?	<input type="checkbox"/> Yes	<input type="checkbox"/> No
2	Is there free air movement to and from the condensing unit?	<input type="checkbox"/> Yes	<input type="checkbox"/> No
3	Is the wiring connected according to the unit wiring diagram?	<input type="checkbox"/> Yes	<input type="checkbox"/> No
4	Are the wiring connections tight (including those in the unit and compressor electrical box)?	<input type="checkbox"/> Yes	<input type="checkbox"/> No
5	Is the unit properly grounded?	<input type="checkbox"/> Yes	<input type="checkbox"/> No
6	Is the circulating air blower correctly wired?	<input type="checkbox"/> Yes	<input type="checkbox"/> No
7	Is the condensing unit properly fused?	<input type="checkbox"/> Yes	<input type="checkbox"/> No
8	Is the thermostat level, correctly wired and in a good location?	<input type="checkbox"/> Yes	<input type="checkbox"/> No
9	Is the ductwork correctly sized, run, taped and insulated?	<input type="checkbox"/> Yes	<input type="checkbox"/> No
10	Is the refrigerant tubing neatly run and the vapor line thoroughly insulated?	<input type="checkbox"/> Yes	<input type="checkbox"/> No
11	Is the condensate drain properly sized, run, trapped and pitched?	<input type="checkbox"/> Yes	<input type="checkbox"/> No
12	Are the refrigerant connections tight and leak tested?	<input type="checkbox"/> Yes	<input type="checkbox"/> No
13	Are the filters clean and in place?	<input type="checkbox"/> Yes	<input type="checkbox"/> No
14	Does the condenser fan turn freely without rubbing?	<input type="checkbox"/> Yes	<input type="checkbox"/> No
15	Is the fan blade tight on the fan shaft?	<input type="checkbox"/> Yes	<input type="checkbox"/> No
16	Are all covers and access panels in place to prevent air loss?	<input type="checkbox"/> Yes	<input type="checkbox"/> No

Accessory Installation

Louvered Panels

1. Remove two screws from top panel where louver will install.
2. Slide top of louver panel under lip of the top panel and slide into place.
3. Attach with four screws provided.

Figure 17: Louver Removal

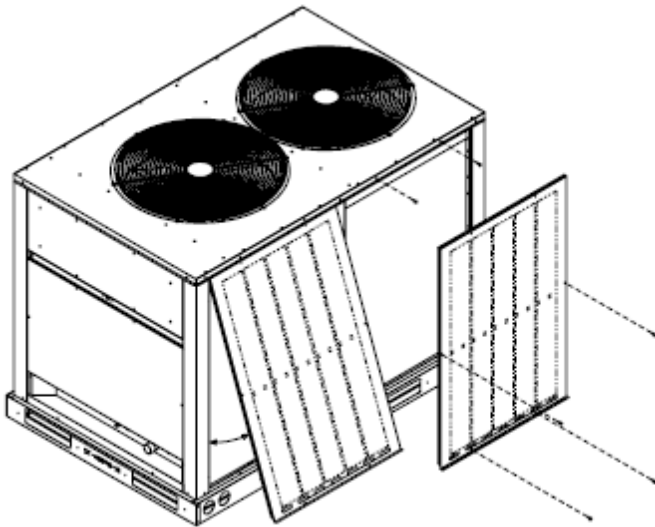

Optional Service Valve

1. Remove clamp securing suction line ext. tube (if applicable).
2. Remove connector panel "A".
3. Remove suction line ext. tube by sweating at reducer/suction line "B" (reducer required on some models and remains on suction line). Remove excess braze material from surface.
4. Slide service valve "C" onto reducer/suction line "B" (DO NOT braze at this time).
5. Install connector panel "A".
6. Install bracket "D".
7. Braze valve.

Maintenance and Operation

IMPORTANT

Refrigerant Piping: A qualified Architect or Systems HVAC Design Engineer familiar with refrigerant piping design, as well as local codes and regulations, must provide refrigerant piping design. The following manufacturer recommendations serve as a general guide and should not replace a qualified professional's refrigerant piping system design.

IMPORTANT

Chilled Water Piping: A qualified Architect or Systems HVAC Design Engineer familiar with piping design, local codes and regulations, must provide piping design. The following manufacturer recommendations serve as a general guide and should not replace a qualified professional's piping system design.

- All access panels must be in place when unit is in operation.
- For maximum efficiency, the condenser coil must be kept clean. Periodic inspections, depending on local conditions are recommended. If it is necessary to clean the condenser coil, use a common garden hose.
- Never operate the unit without filters installed in the air handler.

Crankcase Heaters

All units are equipped with crankcase heaters that are factory wired to operate whenever the main power supply to the unit is "ON" and compressors are "OFF". Before starting the equipment after prolonged shutdown or at the time of initial start-up, be sure that the circuits to the condensing units are closed for at least 24 hours.

Contactors

The contactor is an electrical switch which operates the compressor and condenser fans. Relay activates contactor when safety circuit is made.

High Pressure Switch (HPC)

Opens the contactor circuit on high refrigerant pressure - Manual Reset - check for cause of tripping before putting unit back in service.

WARNING

Do not wire around the high pressure switch. 15 ton unit compressors are not provided with internal pressure relief means. Failure to follow this warning can cause an explosion resulting in personal injury or death.

Low Pressure Switch (LPC)

Acts as safety against loss of refrigerant.

Relay (R)

Energizes the compressor contactor when safety circuit is made.

Replacement Parts

To find your local Daikin McQuay Certified Parts Distributor, go to www.DaikinMcQuay.com and select Parts Locator.

Charge Information

Refer to the appropriate [Charging Charts](#) starting on page 21.

Wiring Diagrams

Refer to the appropriate [Wiring Diagrams](#) starting on page 27.

Troubleshooting

Refer to the troubleshooting chart [Table 15](#) on page 18.

Figure 18: 6-1/2 Ton Charging Charts

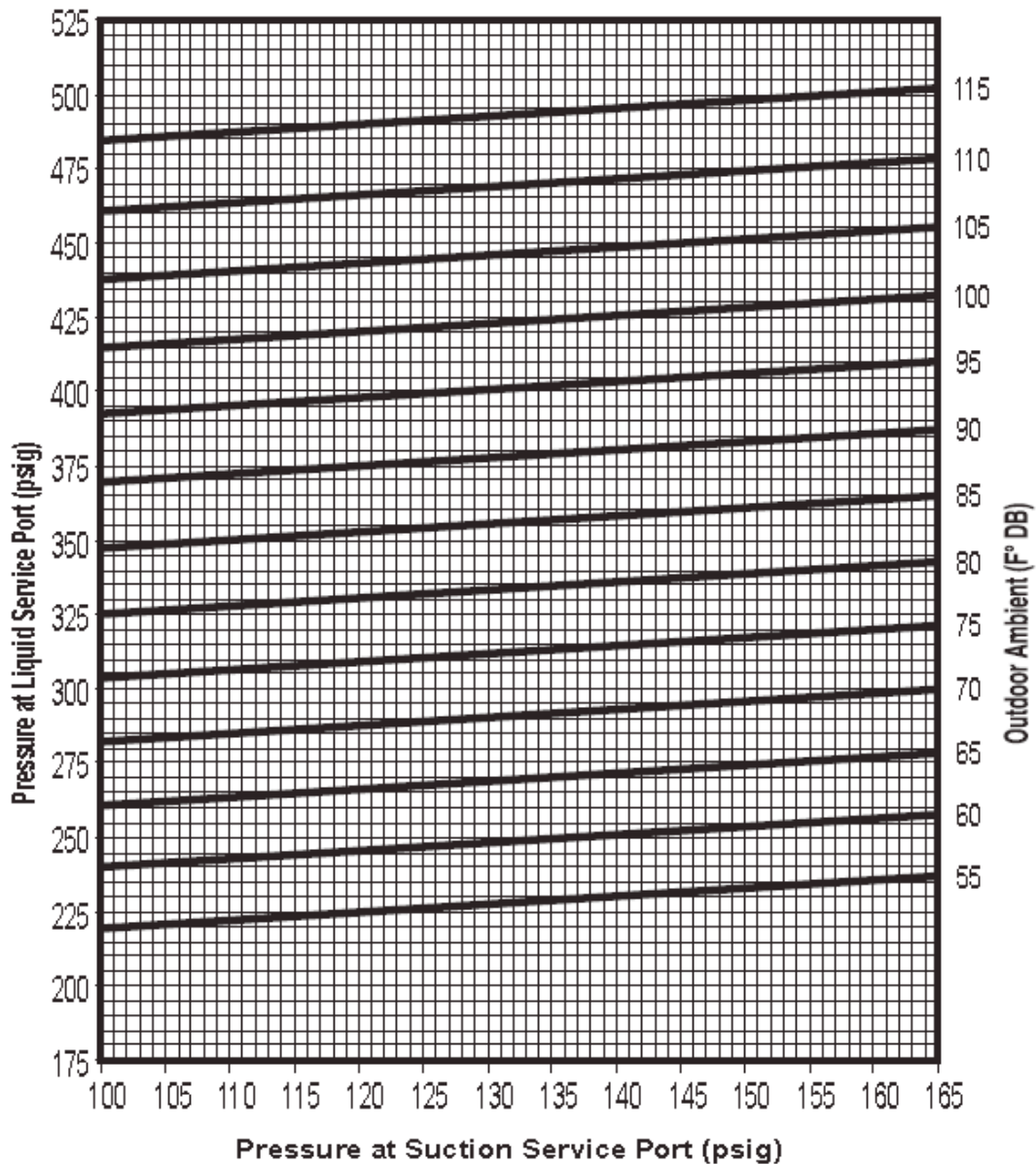

REQUIRED OUNCES R-410A CHARGE PER FOOT OF TUBING		
TUBE SIZE OD. IN.	LIQUID LINE	WVPC LINE
1/2	1.06	
5/8	1.65	
1-1/8		.22
1-3/8		.34

REFRIGERANT REQUIRED: 17.8 OZ. WITH 0 FT. OF SUCTION AND LIQUID LINE.

CAUTION: BEFORE FINAL REFRIGERANT CHECK, INDOOR AIR TEMPERATURE SHOULD BE AT COMFORT CONDITIONS FOR MOST ACCURATE RESULTS.

INSTRUCTIONS:

1. CONNECT PRESSURE GAUGES TO SUCTION AND LIQUID PORTS ON UNIT.
2. MEASURE AIR TEMPERATURE TO OUTDOOR COIL.
3. PLACE AN "X" ON THE APPROPRIATE CHART WHERE THE SUCTION AND LIQUID PRESSURES CROSS.
4. IF "X" IS BELOW AMBIENT TEMPERATURE LINE, ADD CHARGE AND REPEAT STEP 3.
5. IF "X" IS ABOVE AMBIENT TEMPERATURE LINE, RECOVER EXCESS CHARGE AND REPEAT STEP 3.
6. IF CONDENSER FANS ARE NOT RUNNING, THE HEAD PRESSURE CONTROL MAY REQUIRE JUMPING.

Charging Charts

Figure 19: 7-1/2 Ton Charging Chart

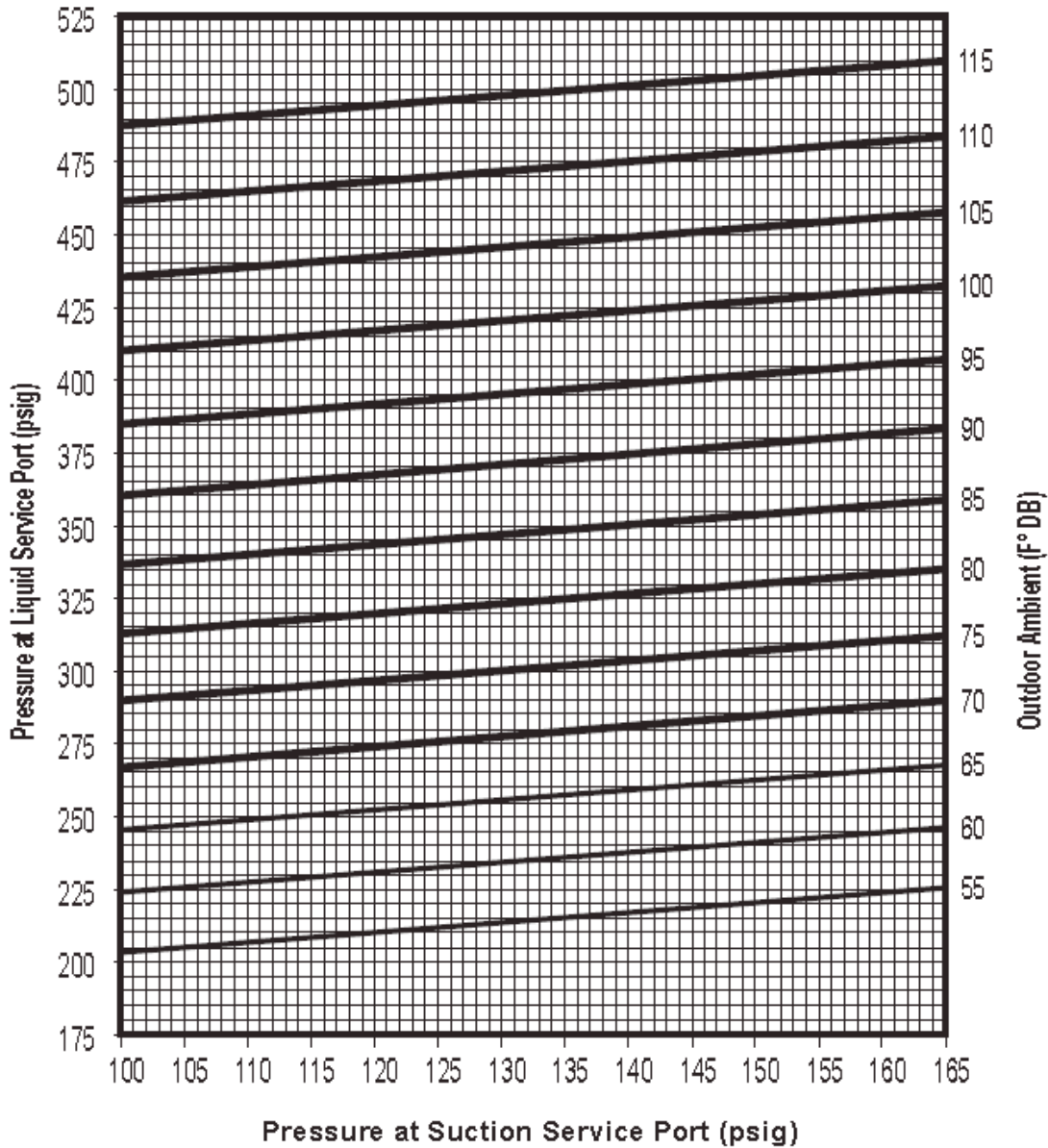

REQUIRED OUNCES R-410A CHARGE PER FOOT OF TUBING		
TUBE SIZE O.D. IN.	LIQUID LINE	VAPOR LINE
1/2	1.06	
5/8	1.65	
1-1/8		2.2
1-3/8		3.4

REFRIGERANT REQUIRED: 239 OZ. WITH 0 FT. OF SUCTION AND LIQUID LINE

CAUTION: BEFORE FINAL REFRIGERANT CHECK, INDOOR AIR TEMPERATURE SHOULD BE AT COMFORT CONDITIONS FOR MOST ACCURATE RESULTS.

INSTRUCTIONS:

1. CONNECT PRESSURE GAUGES TO SUCTION AND LIQUID PORTS ON UNIT.
2. MEASURE AIR TEMPERATURE TO OUTDOOR COIL.
3. PLACE AN "X" ON THE APPROPRIATE CHART WHERE THE SUCTION AND LIQUID PRESSURES CROSS.
4. IF "X" IS BELOW AMBIENT TEMPERATURE LINE, ADD CHARGE AND REPEAT STEP 3.
5. IF "X" IS ABOVE AMBIENT TEMPERATURE LINE, RECOVER EXCESS CHARGE AND REPEAT STEP 3.
6. IF CONDENSER FANS ARE NOT RUNNING, THE HEAD PRESSURE CONTROL MAY REQUIRE JUMPERING.

Figure 20: 10 Ton Charging Chart

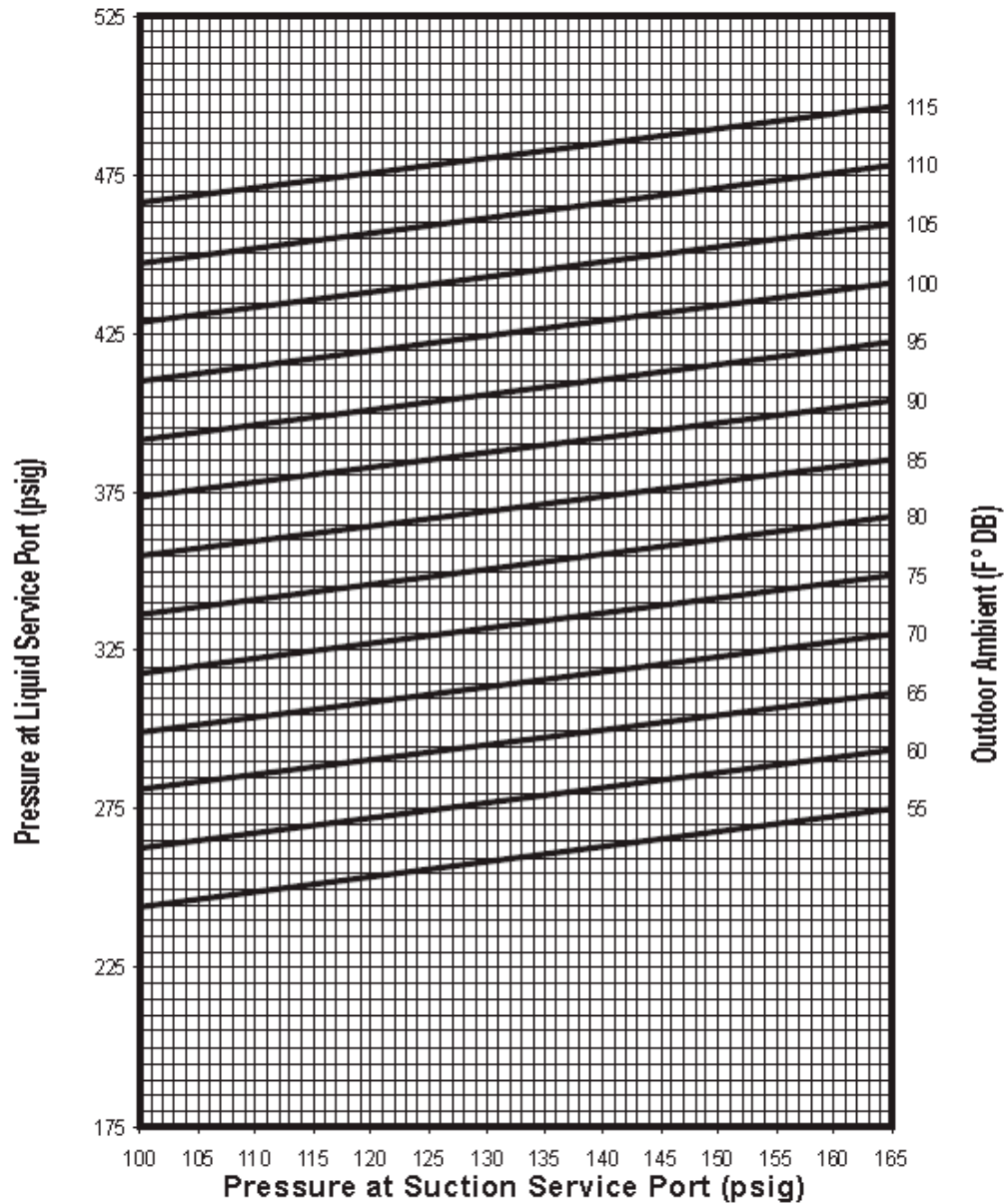

REQUIRED OUNCES R-410A CHARGE PER FOOT OF TUBING		
TUBE SIZE O.D. IN.	LIQUID LINE	WVOR LINE
1/2	1.06	
5/8	1.65	
1-1/8		.22
1-3/8		.34

REFRIGERANT REQUIRED: 300 OZ. WITH 0 FT. OF SUCTION AND LIQUID LINE.

CAUTION: BEFORE FINAL REFRIGERANT CHECK, INDOOR AIR TEMPERATURE SHOULD BE AT COMFORT CONDITIONS FOR MOST ACCURATE RESULTS.

INSTRUCTIONS:

1. CONNECT PRESSURE GAUGES TO SUCTION AND LIQUID PORTS ON UNIT.
2. MEASURE AIR TEMPERATURE TO OUTDOOR COIL.
3. PLACE AN "X" ON THE APPROPRIATE CHART WHERE THE SUCTION AND LIQUID PRESSURES CROSS.
4. IF "X" IS BELOW AMBIENT TEMPERATURE LINE, ADD CHARGE AND REPEAT STEP 3.
5. IF "X" IS ABOVE AMBIENT TEMPERATURE LINE, RECOVER EXCESS CHARGE AND REPEAT STEP 3.
6. IF CONDENSER FANS ARE NOT RUNNING, THE HEAD PRESSURE CONTROL MAY REQUIRE JUMPING.

Charging Charts

Figure 21: 12 Ton Charging Chart

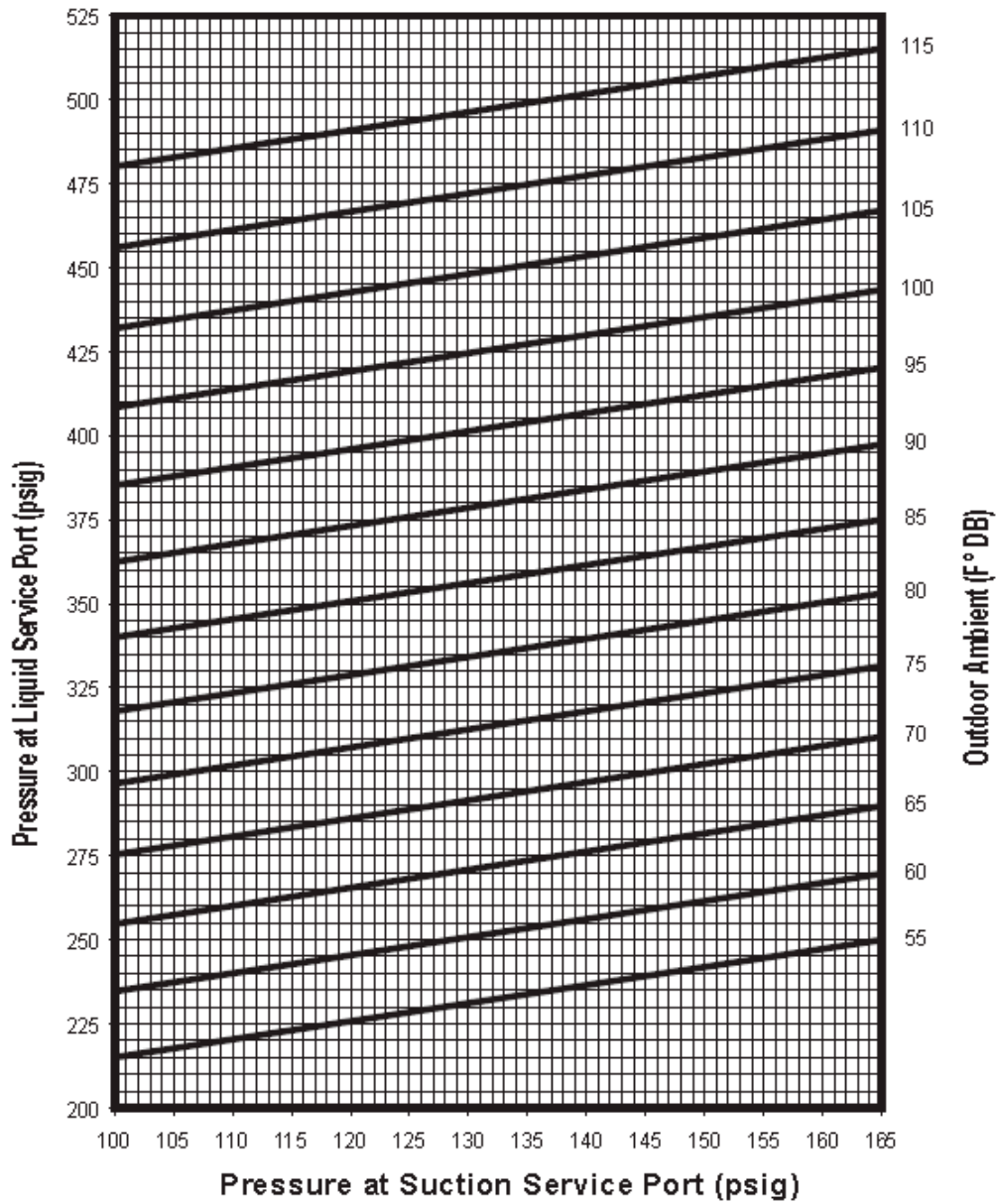

REQUIRED OUNCES R-410A CHARGE PER FOOT OF TUBING		
TUBE SIZE O.D. IN.	LIQUID LINE	VAPOR LINE
1/2	1.06	
5/8	1.65	
1-1/8		.22
1-3/8		.34

REFRIGERANT REQUIRED: 378 OZ. WITH 0 FT. OF SUCTION AND LIQUID LINE.

CAUTION: BEFORE FINAL REFRIGERANT CHECK, INDOOR AIR TEMPERATURE SHOULD BE AT COMFORT CONDITIONS FOR MOST ACCURATE RESULTS.

INSTRUCTIONS:

1. CONNECT PRESSURE GAUGES TO SUCTION AND LIQUID PORTS ON UNIT.
2. MEASURE AIR TEMPERATURE TO OUTDOOR COIL.
3. PLACE AN "X" ON THE APPROPRIATE CHART WHERE THE SUCTION AND LIQUID PRESSURES CROSS.
4. IF "X" IS BELOW AMBIENT TEMPERATURE LINE, ADD CHARGE AND REPEAT STEP 3.
5. IF "X" IS ABOVE AMBIENT TEMPERATURE LINE, RECOVER EXCESS CHARGE AND REPEAT STEP 3.
6. IF CONDENSER FANS ARE NOT RUNNING, THE HEAD PRESSURE CONTROL MAY REQUIRE JUMPING.

Figure 22: 15 Ton Charging Chart

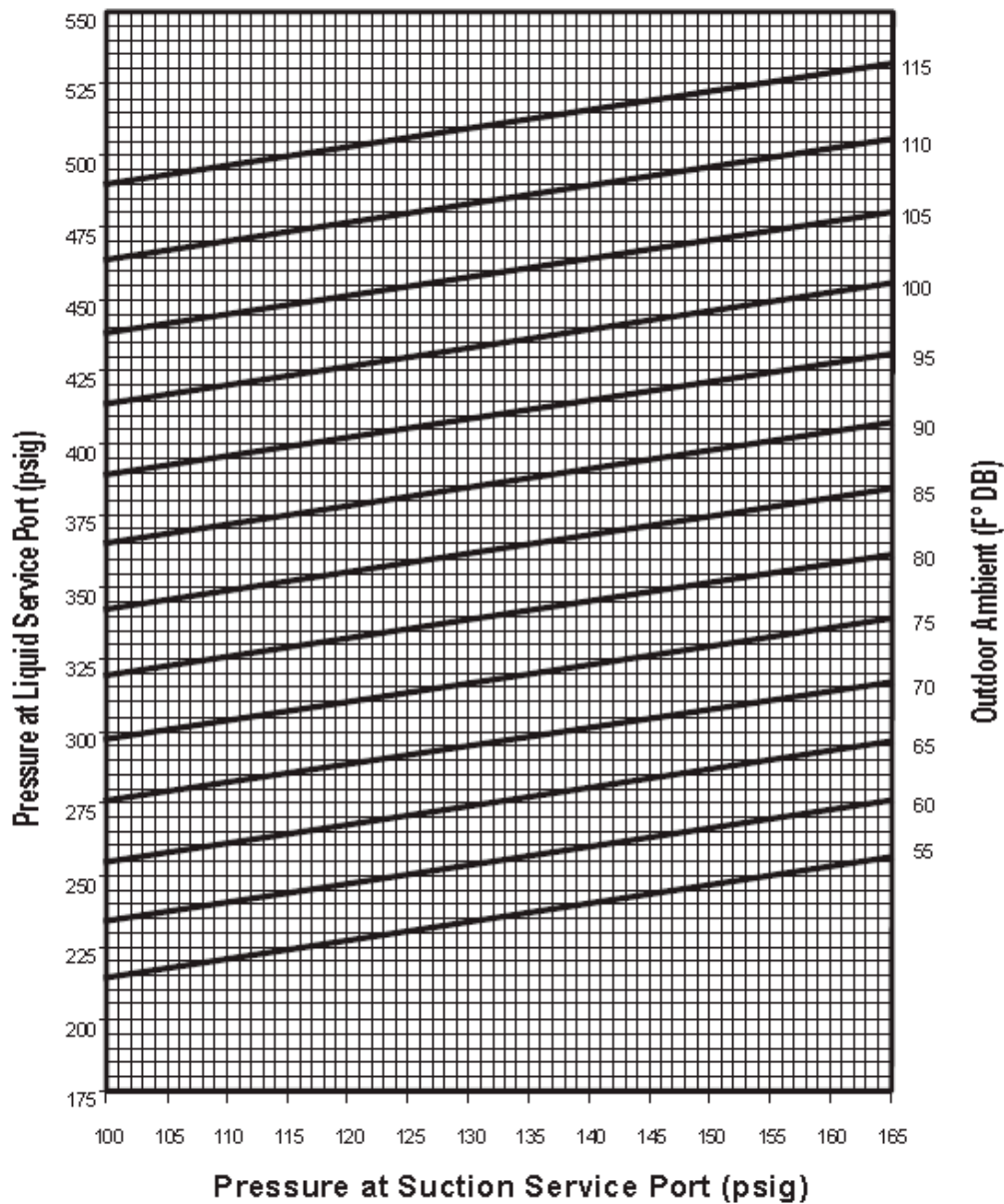

REQUIRED OUNCES R-410A CHARGE PER FOOT OF TUBING		
TUBE SIZE O.D. IN.	LIQUID LINE	VAPOR LINE
1/2	1.06	
5/8	1.65	
1-1/8		.22
1-3/8		.34

REFRIGERANT REQUIRED: 506 OZ. WITH 0 FT. OF SUCTION AND LIQUID LINE.

CAUTION: BEFORE FINAL REFRIGERANT CHECK, INDOOR AIR TEMPERATURE SHOULD BE AT COMFORT CONDITIONS FOR MOST ACCURATE RESULTS.

INSTRUCTIONS:

1. CONNECT PRESSURE GAUGES TO SUCTION AND LIQUID PORTS ON UNIT.
2. MEASURE AIR TEMPERATURE TO OUTDOOR COIL.
3. PLACE AN "X" ON THE APPROPRIATE CHART WHERE THE SUCTION AND LIQUID PRESSURES CROSS.
4. IF "X" IS BELOW AMBIENT TEMPERATURE LINE, ADD CHARGE AND REPEAT STEP 3.
5. IF "X" IS ABOVE AMBIENT TEMPERATURE LINE, RECOVER EXCESS CHARGE AND REPEAT STEP 3.
6. IF CONDENSER FANS ARE NOT RUNNING, THE HEAD PRESSURE CONTROL MAY REQUIRE JUMPERING.

Charging Charts

Figure 23: 20 Ton Charging Chart

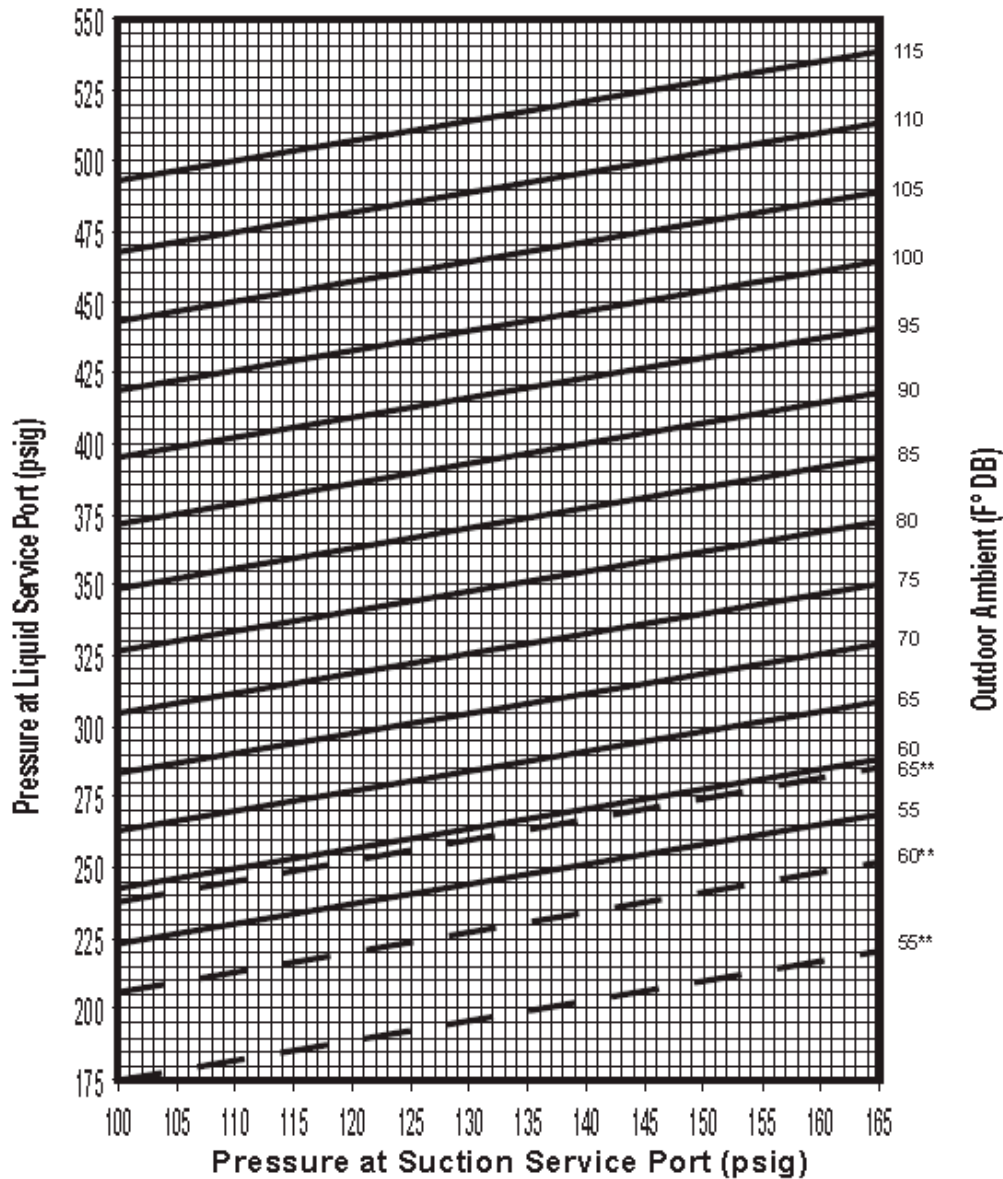

REQUIRED OUNCES R-410A CHARGE PER FOOT OF TUBING		
TUBE SIZE OD. IN.	LIQUID LINE	WVOR LINE
1/2	1.06	
5/8	1.65	
1-1/8		.22
1-3/8		.34

REFRIGERANT REQUIRED: 655 OZ. WITH 0 FT. OF SUC TION AND LIQUID LINE.

CAUTION: BEFORE FINAL REFRIGERANT CHECK, INDOOR AIR TEMPERATURE SHOULD BE AT COMFORT CONDITIONS FOR MOST AC CURATE RESULTS.

INSTRUCTIONS:

1. CONNECT PRESSURE GUAGES TO SUC TION AND LIQUID PORTS ON UNIT.
2. MEASURE AIR TEMPERATURE TO OUT DOOR COIL.
3. PLACE AN "X" ON THE APPROPRIATE CHART WHERE THE SUC TION AND LIQUID PRESSURES CROSS.
4. IF "X" IS BELOW AMBIENT TEMPERATURE LINE, ADD CHARGE AND REPEAT STEP 3.
5. IF "X" IS ABOVE AMBIENT TEMPERATURE LINE, REC OVER EXCESS C HARGE AND REPEAT STEP 3.
6. IF CONDENSER FANS ARE NOT RUNNING, THE HEAD PRESSURE CONTROL MAY REQUIRE JUMPERING.

** DOTTED LINES INDICATE ONLY 1 COMPRESSOR OPERATING.

Figure 24: Typical Wiring Schematic - RCS 06F-10F

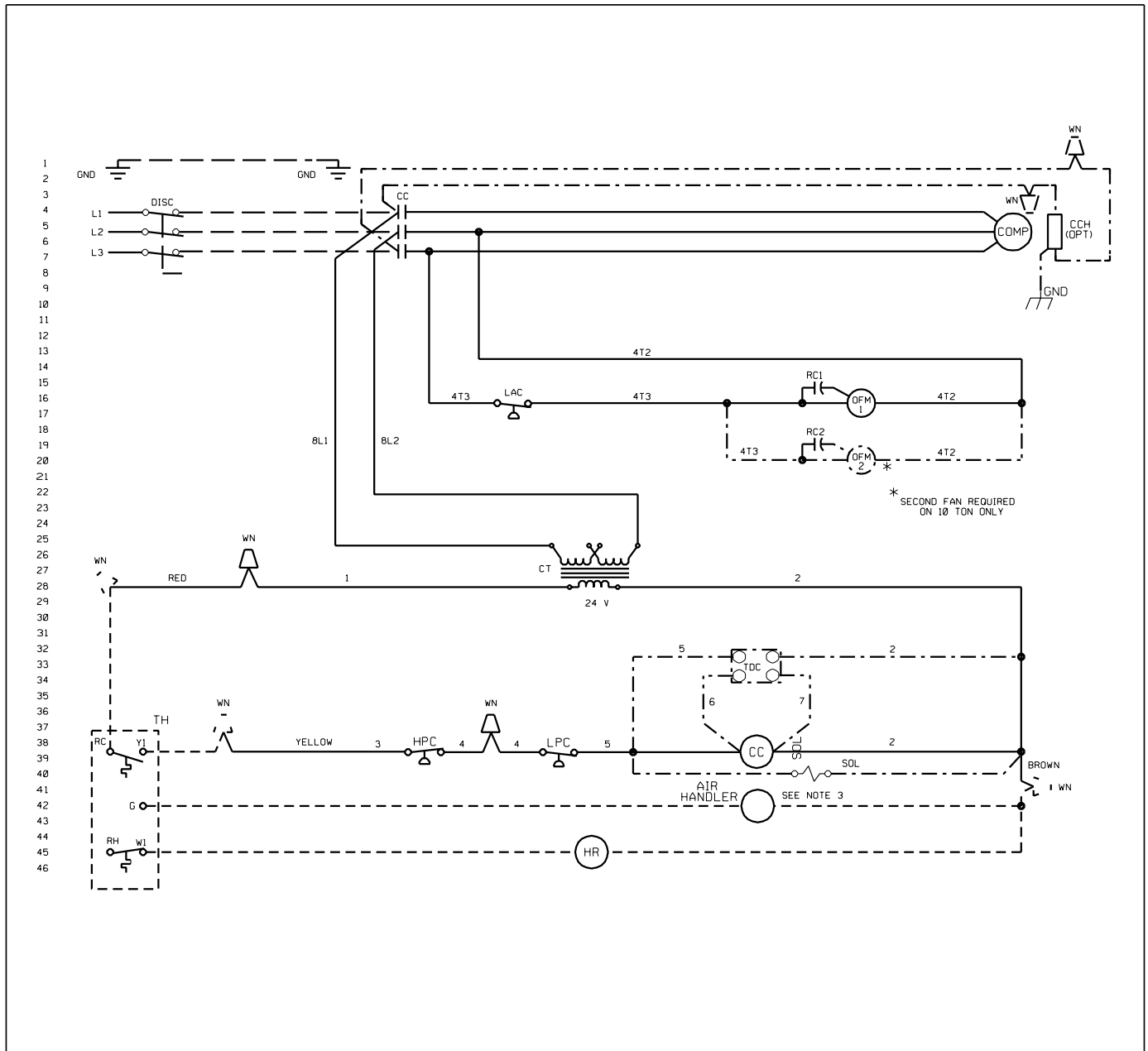

DWG. NO. 90-42456-02 REV 14	COMPONENT CODE CC COMPRESSOR CONTACTOR CCH CRANKCASE HEATER COMP COMPRESSOR CT CONTROL TRANSFORMER HPC HIGH PRESSURE CONTROL HR HEATER RELAY LAC LOW AMBIENT CONTROL LPC LOW PRESSURE CONTROL OFM OUTDOOR FAN MOTOR RC RUN CAPACITOR TH THERMOSTAT (H/C) TDC TIME DELAY CONTROL WN WIRE NUT	NOTES: REPLACEMENT WIRE & FUSES MUST BE 1. SAME TYPE & SIZE AS ORIGINAL. 2. UNIT MUST BE PERMANENTLY GROUNDED & CONFORM TO N.E.C. & LOCAL CODES. 3. MAXIMUM IN RUSH VA NOT TO EXCEED 92 VA. 4. MINIMUM WIRE SIZE BASED ON 75 DEGREE'S C INSULATION COPPER WIRE.	WIRING INFORMATION LINE VOLTAGE -FACTORY STANDARD _____ -FACTORY OPTION - - - - - -FIELD INSTALLED - - - - - LOW VOLTAGE -FACTORY STANDARD _____ -FACTORY OPTION - - - - - -FIELD INSTALLED - - - - - REPLACEMENT WIRE -MUST BE THE SAME SIZE AND TYPE OF INSULATION AS ORIGINAL (105° C MIN.) WARNING -CABINET MUST BE PERMANENTLY GROUNDED AND CONFORM TO I.E.C., N.E.C., C.E.C., NATIONAL WIRING REGULATIONS, AND LOCAL CODES AS APPLICABLE.	WIRE COLOR CODE BK__BLACK BR__BROWN BL__BLUE G__GREEN GY__GRAY O__ORANGE PR__PURPLE R__RED W__WHITE Y__YELLOW
	WIRING SCHEMATIC CONDENSING UNIT 208/230, 380, 460 3PH 60Hz & 200/220, 380/415 3PH 50Hz & 6½ & 7½ TON - 575 3PH 60Hz			DR. BY MCB APP. BY DATE 8-29-90 DWG. NO. 90-42456-02 REV 14

Wiring Diagrams

Figure 25: Typical Wiring Schematic - RCS 11F-20F

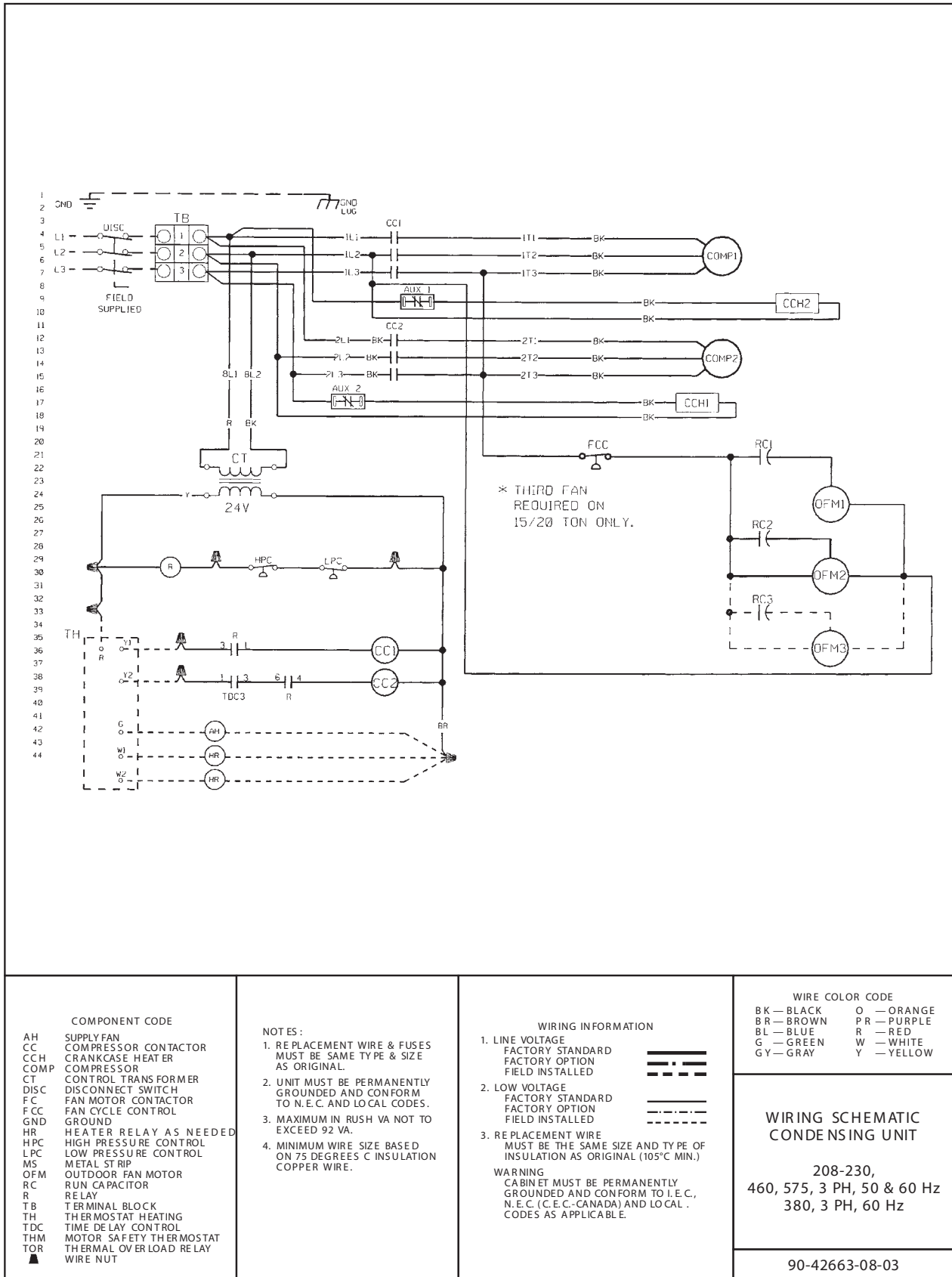

Replacement Parts

When contacting Daikin McQuay for service or replacement parts, provide the model number, serial number, and unit part number of the unit as stamped on the serial plate attached to the unit. For questions regarding wiring diagrams, provide the number on the specific diagram. If replacement parts are required, include the date of unit installation, the date of failure, an explanation of the malfunction, and a description of the replacement parts required.

Scroll Compressor

All Daikin McQuay Rooftop products include a first-year parts only warranty. The warranty period extends 12 months from startup or 18 months from date of shipment, whichever comes first. Labor to install these parts is not included with this warranty. Compressors are considered a part and are included in this standard warranty.

All Compressors

Replacement compressors for Daikin McQuay Rooftop Units can be obtained from the Daikin McQuay Service Parts department.

1. Contact the Daikin McQuay Parts Department for compressor availability.
2. Send a completed parts order form to the Daikin McQuay Parts Department.
3. The Parts Department processes the order and the compressors are shipped from our Dayton, OH warehouse via ground transportation. If next-day air is required, indicate this on the parts order form and a freight charge will be billed to your account. Air freight costs are not covered under the Daikin McQuay warranty.
4. After the failed compressor is replaced, return it to Daikin McQuay with a Return Goods Tag attached, which you will receive in the mail. It must be attached to the compressor. The Return Goods Tag has instructions on where to send the compressor. If the compressor is not returned, you will be billed for the replacement compressor.
5. Consideration may be given at this time to a compressor teardown analysis, depending on the history of failures.

In-Warranty Return Material Procedure

Material other than compressors may not be returned except by permission of authorized factory service personnel of Daikin McQuay at Minneapolis, Minnesota.

A “return goods” tag will be sent to be included with the returned material. Enter the information as called for on the tag in order to expedite handling at our factories and issuance of credits. All parts shall be returned to the factory designated on the return goods tag, transportation charges prepaid.

The return of the part does not constitute an order for replacement. A purchase order for the replacement part must be entered through your nearest Daikin McQuay representative. The order should include the component’s part number and description and the model and serial numbers of the unit involved.

If it is determined that the failure of the returned part is due to faulty material or workmanship within the standard warranty period, credit will be issued on the customer’s purchase order.

Warranty Registration Form

DAIKIN McQUAY® To comply with the terms of Daikin McQuay Warranty, complete and return this Equipment Warranty Registration Form within 10 days to Daikin McQuay, Warranty Department.

Check, test, and start procedure for RoofPak roof mounted air conditioners with or without heat recovery and roof mounted air handlers.

Job Name: _____ McQuay G.O. No.: _____
 Installation address: _____
 City: _____ State: _____
 Purchasing contractor: _____
 City: _____ State: _____
 Name of Person doing start-up (print) _____
 Company name _____
 Address _____
 City/State/Zip _____

Unit model number: _____ Unit serial number: _____
 Compressor #1 model number: _____ Serial number: _____
 Compressor #2 model number: _____ Serial number: _____

Circle Yes or No. If not applicable to the type of unit, circle N/A.

I. INITIAL CHECK

- A. Is any shipping damage visible? Yes No N/A
- B. Tightened all setscrews? Yes No N/A
- C. Have the shipping spacers been removed from the compressor springs and have the neoprene spacers been installed on each compressor mounting bolt? (Only applies to 115C-135C units with compressor spring isolators.)? Yes No N/A
- D. Electrical service corresponds to unit nameplate? Yes No N/A
 Volts _____ Hertz _____ Phase _____
- E. Is the main disconnect adequately fused and are fuses installed? Yes No N/A
- F. Are crankcase heaters operating, and have they been operating 24 hours prior to start-up? Yes No N/A
- G. Are all electrical power connections tight (Check compressor electrical box.) Yes No N/A
- H. Has the field piping been piped per ASHRAE recommendations? Yes No N/A

II. START-UP COMPRESSOR OPERATION

- A. Has each circuit been field leak tested? Yes No N/A
- B. Circuit 1 Yes No N/A
- C. Circuit 2 Yes No N/A
- D. Refrigerant charge per circuit: Circuit 1 _____ Circuit 2 _____
- E. Do condenser fans rotate in the right direction? Yes No N/A
- F. Are compressors rotating in the right direction? Yes No N/A
- G. Ambient temperature: _____°F
- H. Compressor lockout timers function? Yes No N/A
- I. Does unit start up and perform per sequence of operation? Yes No N/A

III. PERFORMANCE DATA

A. Compressor voltage across each phase:	L1-2 _____ V	L2-3 _____ V	L1-3 _____ V
B. Compressor amperage of fully loaded compressor:			
Compressor #1:	Phase 1 _____	Phase 2 _____	Phase 3 _____
Compressor #2:	Phase 1 _____	Phase 2 _____	Phase 3 _____
C. Low pressure cut-out:	Circuit 1 _____	psig	Circuit 2 _____
Low pressure cut-in:	Circuit 1 _____	psig	Circuit 2 _____
D. High pressure cut-out:	Circuit 1 _____	psig	Circuit 2 _____
E. Discharge pressure, one compressor:	Circuit 1 _____	psig	Circuit 2 _____
F. Discharge pressure, fully loaded:	Circuit 1 _____	psig	Circuit 2 _____
G. Suction pressure, one compressor:	Circuit 1 _____	psig	Circuit 2 _____
Suction pressure, fully loaded:	Circuit 1 _____	psig	Circuit 2 _____
Liquid press, fully loaded (at liquid line shut-off valve):	Circuit 1 _____	psig	Circuit 2 _____
Liquid temperature, fully loaded:	Circuit 1 _____	psig	Circuit 2 _____

Warranty Registration Form

H. Suction Line temperature: _____ °F _____ °F
I. Superheat: _____ °F _____ °F
J. Supercooling: _____ °F _____ °F
K. Is the liquid in the liquid line sightglass clear and dry? Yes No N/A
L. At what suction pressure does the hot gas bypass valve open? Circuit 1 _____ psig Circuit 1 _____ psig
M. Record discharge air temperature at discharge of the air handler: _____ °F
N. Are all control lines secure to prevent excessive vibration and wear? Yes No N/A
O. Are all gauges shut off and valve caps and packings tight after start-up? Yes No N/A

Signature: _____ Start-up date: _____

Please see the following page "Quality Assurance Survey Report" and list any additional comments that could affect the operation of this unit; e.g., shipping damage, failed components, adverse installation applications, etc. If additional comment space is needed, write the comment(s) on a separate sheet, attach it to the Survey Report and return it to the Warranty Department with the above completed Warranty Registration form.

RETURN COMPLETED EQUIPMENT WARRANTY REGISTRATION FORM TO:
Daikin McQuay Warranty Department, 13600 Industrial Park Boulevard, Minneapolis, MN 55441

Quality Assurance Survey Form



Quality Assurance Survey Report

To whom it may concern:

Please review the items below upon receiving and installing our product. Mark N/A on any item that does not apply to the product.

Job Name: _____ McQuay G.O. No. _____

Installation address: _____

City: _____ State: _____

Purchasing contractor: _____

City: _____ State: _____

Name of person doing start-up (print): _____

Company name: _____

Address: _____

City/State/Zip: _____

1. Is there any shipping damage visible? Yes No N/A

Location on unit _____

2. How would you rate the overall appearance of the product; i.e., paint, fin damage, etc.?

Excellent Good Fair Poor

3. Did all sections of the unit fit together properly? Yes No N/A

4. Did the cabinet have any air leakage? Yes No N/A

Location on unit _____

5. Were there any refrigerant leaks? Yes No N/A

From where did it occur? Shipping Workmanship Design

6. Does the refrigerant piping have excessive vibration? Yes No N/A

Location on unit _____

7. Did all of the electrical controls function at start-up? Yes No N/A

Comments _____

8. Did the labeling and schematics provide adequate information? Yes No N/A

9. How would you rate the serviceability of the product?

Excellent Good Fair Poor

10. How would you rate the overall quality of the product?

Excellent Good Fair Poor

11. How does the quality of McQuay products rank in relation to competitive products?

Excellent Good Fair Poor

Comments _____

Please list any additional comments which could affect the operation of this unit; i.e., shipping damage, failed components, adverse installation applications, etc. If additional comment space is needed, write the comment(s) on a separate sheet, attach the sheet to this completed Quality Assurance Survey Report, and return it to the Warranty Department with the completed preceding "Equipment Warranty Registration Form".

Daikin McQuay Training and Development

Now that you have made an investment in modern, efficient Daikin McQuay equipment, its care should be a high priority. For training information on all Daikin McQuay HVAC products, please visit us at www.DaikinMcQuay.com and click on training, or call 540-248-9646 and ask for the Training Department.

Warranty

All Daikin McQuay equipment is sold pursuant to its standard terms and conditions of sale, including Limited Product Warranty. Consult your local Daikin McQuay Representative for warranty details. Refer to Form 933-430285Y. To find your local Daikin McQuay Representative, go to www.DaikinMcQuay.com.

Aftermarket Services

To find your local parts office, visit www.DaikinMcQuay.com or call 800-37PARTS (800-377-2787). To find your local service office, visit www.DaikinMcQuay.com or call 800-432-1342.

This document contains the most current product information as of this printing. For the most up-to-date product information, please go to www.DaikinMcQuay.com.

Products manufactured in an ISO Certified Facility.

DAIKIN McQUAY®