

UPLIFT CONNECTIONS- 130MPH WINDS EXP. "B"						
CONNECTION	FRAMING SPACING (in.)	ROOF SPAN (ft.)	U	L	S	NUM. OF 8d COM. NAILS OR 10d BOX NAILS IN EA. END OF 1-1/4"x20 GA. STRAP
ROOF ASSEMBLY TO WALL ASSEMBLY	16" O.C.	17	386	246	109R	4
WALL ASSEMBLY TO WALL ASSEMBLY	16" O.C.	17	386	246	109R	4
WALL ASSEMBLY TO FOUNDATION	16" O.C.	17	170	185	436	4

THERMAL COMPONENT CRITERIA (U-FACTOR AND R-VALUE)					
MAX. GLAZING U-FACTOR	MINIMUM INSULATION R-VALUE				
	CEILINGS	WALLS	FLOORS	BASEMENT WALLS	CRAWL SPACE WALLS
.75	R-26	R-13	R-11	R-5	R-5

WINDBORNE DEBRIS PROTECTION FASTENING SCHEDULE FOR WOOD STRUCTURAL PANELS				
FASTENER TYPE	FASTENER SPACING			
	PANEL SPAN ≤ 4 FOOT	4 FOOT PANEL SPAN ≤ 6 FOOT	6 FOOT PANEL SPAN ≤ 8 FOOT	8 FOOT PANEL SPAN ≤ 12 FOOT
2-1/2" #6 WOOD SCREWS	16"	12"	9"	6"
2-1/2" #8 WOOD SCREWS	16"	16"	12"	9"

JACK STUD REQUIREMENTS-FOR INTERIOR LOADBEARING WALLS													
HEADER SUPPORTING	HEADER SPAN (ft.)	ROOF SPAN (ft.)											
		12 FEET				24 FEET				36 FEET			
		3"	4.5"	5"	6.5"	3"	4.5"	5"	6.5"	3"	4.5"	5"	6.5"
NO. JACK STUDS REQ.													
ROOF AND CEILING	2	1	1	1	1	1	1	1	1	1	1	1	
	4	1	1	1	1	1	1	1	1	1	1	1	
	6	1	1	1	1	1	1	1	1	1	1	1	
	8	1	1	1	1	2	1	1	1	2	2	2	
	10	1	1	1	1	2	2	1	1	3	2	2	
	12	1	1	1	1	2	2	2	1	3	2	2	
	14	2	1	1	1	3	2	2	2	4	3	3	
ROOF, CEILING, AND 1 CENTER BEARING FLR.	2	1	1	1	1	1	1	1	1	1	1	1	
	4	1	1	1	1	2	1	1	1	3	2	2	
	6	2	1	1	1	3	2	2	2	4	3	3	
	8	2	2	1	1	3	2	2	2	5	3	3	
	10	2	2	2	1	4	3	3	2	6	4	4	
	12	3	2	2	2	5	3	3	3	7	5	4	
	14	3	2	2	2	5	4	3	3	8	5	5	
16	4	3	2	2	6	4	4	3	9	6	5		

SILL or BOTTOM PLATE TO FND. CONNECTIONS RESISTING UPLIFT LOADS-130MPH WINDS EXP. "B"			
BOTTOM PLATE TO FND. ANCHOR BOLT CONNECTION RESISTING	FOUNDATION SUPPORTING	MAX. ANCHOR BOLT SPACING (in.)	
		8' END ZONES	INTERIOR ZONES
UPLIFT LOADS	1-3 STORIES	28	33

SILL or BOTTOM PLATE TO FND. CONNECTIONS RESISTING SHEAR LOADS-130MPH WINDS EXP. "B"			
BOTTOM PLATE TO FND. ANCHOR BOLT CONNECTION RESISTING	FOUNDATION SUPPORTING	MAX. ANCHOR BOLT SPACING (in.)	
		1/2" ANC. BOLTS	5/8" ANC. BOLTS
SHEAR LOADS	1-3 STORIES	30	45

HEADER SPANS-FOR INT. LOADBEARING WALLS				
HEADER SUPPORTING	SIZE	BLDG. WIDTH (ft.)		
		12	24	36
		SPAN (ft.-in.)		
ONE FLOOR (CENTER BEARING)	(2)2x4S	4'-4"	3'-1"	2'-6"
	(2)2x6S	6'-5"	4'-6"	3'-8"
	(2)2x8S	8'-1"	5'-9"	4'-8"
	(2)2x10S	9'-11"	7'-0"	5'-9"
	(2)2x12S	11'-6"	8'-1"	6'-7"
	(3)2x8S	10'-2"	7'-2"	5'-10"
	(3)2x10S	12'-5"	8'-9"	7'-2"
	(3)2x12S	14'-4"	10'-2"	8'-3"
	(4)2x8S	11'-6"	8'-3"	6'-9"
	(4)2x10S	14'-4"	10'-1"	8'-3"
2 FLOORS ONLY (CENTER BEARING)	(2)2x4S	2'-10"	2'-1"	1'-8"
	(2)2x6S	4'-2"	3'-1"	2'-6"
	(2)2x8S	5'-4"	3'-11"	3'-3"
	(2)2x10S	6'-6"	4'-9"	3'-11"
	(2)2x12S	7'-6"	5'-6"	4'-7"
	(3)2x8S	6'-8"	4'-10"	4'-0"
	(3)2x10S	8'-1"	6'-0"	4'-11"
	(3)2x12S	9'-5"	6'-11"	5'-9"
	(4)2x8S	7'-8"	5'-8"	4'-8"
	(4)2x10S	9'-4"	6'-10"	5'-8"

HEADER SPANS-EXPOSURE B FOR EXTERIOR LOADBEARING WALLS			
HEADER SIZE	SPAN	NO. FULL HGT. STUDS REQ. AT EA. END	
(2)2x4S	4'-7"	2	
(2)2x6S	5'-6"	2	
(2)2x8S	6'-1"	3	
(2)2x10S	6'-8"	3	
(2)2x12S	7'-1"	3	
(3)2x8S	7'-5"	3	
(3)2x10S	8'-3"	3	
(3)2x12S	8'-8"	3	
(4)2x8S	8'-7"	3	
(4)2x10S	9'-6"	3	
(4)2x12S	10'-0"	4	

NOTE:
1. BLDG. WIDTH IS MEASURED PERPENDICULAR TO THE RIDGE. FOR WIDTHS BETWEEN THOSE SHOWN, SPANS ARE PERMITTED TO BE INTERPOLATED.
2. ALL HEADERS SHALL HAVE SOLID BLOCKING.

JACK STUD REQ.-EXP. B FOR EXT. LOADBEARING WALLS				
HEADER SUPPORTING	HEADER SPAN (ft.)	HEADER WIDTH NO. JACK STUDS REQ.		
		3"	4.5"	5" 6.5"
ROOF AND CEILING	2	1	1	1
	4	1	1	1
	6	2	2	2
	8	2	2	2
	10	3	2	2
	12	3	2	2
	14	4	3	2
ROOF, CEILING, AND 1 CENTER BEARING FLR.	2	1	1	1
	4	2	1	1
	6	2	2	1
	8	3	2	2
	10	4	3	2
	12	4	3	2
	14	5	3	3

WALL SHEATH. OR CLAD. REQ. FOR WIND LOAD-EXP. B				
SHEATHING LOCATION	STUD SPAC.	MAX. NAIL SPAC. FOR 8d COM. NAILS OR 10d BOX NAILS (INCHES, O.C.)		
		E	F	
INTERIOR ZONE	12" O.C.	6	12	
	16" O.C.	6	12	
	24" O.C.	6	12	
PERIMETER EDGE ZONE	12" O.C.	6	12	
	16" O.C.	6	12	
	24" O.C.	6	12	

HEADER NAILING SCHEDULE			
DESCRIPTION	NUM. OF COM. NAILS	NUM. OF BOX NAILS	SPACING
HEAD. TO HEAD. (FACE-NAILED)	8d	10d	6" O.C. EDGES/ 12" O.C. FIELD

NOTE:
ALL HEADERS SHALL HAVE SOLID BLOCKING

ROOF SHEATH. OR CLAD. REQ. FOR WIND LOAD-EXP. B				
SHEATHING LOCATION	RAFTER/TRUSS SPAC.	MAX. NAIL SPAC. FOR 8d COM. NAILS OR 10d BOX NAILS (INCHES, O.C.)		
		E	F	
INTERIOR ZONE	12" O.C.	6	12	
	16" O.C.	6	12	
	24" O.C.	6	12	
PERIMETER EDGE ZONE	12" O.C.	6	12	
	16" O.C.	6	12	
	24" O.C.	6	12	

ROOF UNDERLAYMENT APPLICATION

FOR ROOF SLOPES FROM TWO UNITS VERTICAL IN 12 UNITS HORIZONTAL (17-PERCENT SLOPE), UP TO FOUR UNITS VERTICAL IN 12 UNITS HORIZ. (33-PERCENT SLOPE), UNDERLAYMENT SHALL BE TWO LAYERS APPLIED IN THE FOLLOWING MANNER:

APPLY A 1/8 INCH STRIP OF UNDERLAYMENT FELT PARALLEL WITH AND STARTING AT THE EAVES, FASTENED SUFFICIENTLY TO HOLD IN PLACE. STARTING AT THE EAVE, APPLY 36 INCH WIDE SHEETS OF UNDERLAYMENT, OVERLAPPING SUCCESSIVE SHEETS 19 INCHES, AND FASTENED SUFFICIENTLY TO HOLD IN PLACE.

FOR ROOF SLOPES OF FOUR UNITS VERTICAL IN 12 UNITS HORIZONTAL (33-PERCENT SLOPE) OR GREATER, UNDERLAYMENT SHALL BE ONE LAYER APPLIED IN THE FOLLOWING MANNER:

UNDERLAYMENT SHALL BE APPLIED SHINGLE FASHION, PARELLEL TO AND STARTING FROM THE EAVE AND LAPPED 2 INCHES, FASTENED SUFFICIENTLY TO HOLD IN PLACE. END LAPS SHALL BE OFFSET BY 6 FEET.

SHINGLE APPLICATION/FASTENING

ASPHALT STRIP SHINGLES SHALL HAVE A MINIMUM OF SIX FASTENERS PER SHINGLE WHERE THE ROOF IS IN ONE OF THE FOLLOWING CATEGORIES:

1. THE BASIC WIND SPEED IS 110 MPH OR GREATER AND THE EAVE IS 20 FEET OR HIGHER ABOVE GRADE.
2. THE BASIC WIND SPEED IS 120 MPH OR GREATER.
3. SPECIAL WIND ZONES.

UPLIFT CONNECTIONS

ROOF ASSEMBLY TO WALL ASSEMBLY:

UPLIFT CONNECTIONS SHALL BE FROM RAFTER OR TRUSS TO WALL STUD. WHEN RAFTERS OR TRUSSES ARE NOT LOCATED DIRECTLY ABOVE STUDS, RAFTERS SHALL BE ATTACHED TO THE WALL PLATE AND THE WALL TOP PLATE SHALL BE ATTACHED TO THE WALL STUD WITH UPLIFT CONNECTIONS. UPLIFT CONNECTIONS SHALL BE IN ACCORDANCE WITH TABLE.

WALL ASSEMBLY TO WALL ASSEMBLY:

STORY TO STORY UPLIFT CONNECTIONS FROM UPPER STORY WALL STUD TO LOWER STORY WALL STUD. WHEN UPPER STORY WALL STUDS ARE NOT LOCATED DIRECTLY ABOVE LOWER WALL STUDS, THE STUDS SHALL BE ATTACHED TO A COMMON MEMBER IN THE FLOOR ASSEMBLY BY UPLIFT CONNECTIONS. UPLIFT CONNECTIONS SHALL BE IN ACCORDANCE WITH TABLE.

WALL ASSEMBLY TO FOUNDATION:

FIRST FLOOR WALL STUDS SHALL BE CONNECTED TO THE FOUNDATION, SILL, PLATE, OR BOTTOM PLATE. A MINIMUM OF A 1-1/4" x 20 GA. ASTM A653 GRADE 33 STEEL STRAP SHALL BE NAILED TO THE WALL STUDS AND HAVE A MINIMUM EMBEDMENT OF 7 INCHES IN CONCRETE FOUNDATIONS AND SLABS-ON-GRADE, 15 INCHES IN MASONRY BLOCK FOUNDATIONS, OR BE LAPPED UNDER THE BOTTOM PLATE, 3 INCH SQUARE WASHERS SHALL BE USED ON THE ANCHOR BOLTS AND ANCHOR BOLT SPACINGS SHALL NOT EXCEED THE REQUIREMENTS. STEEL STRAPS EMBEDDED IN OR IN CONTACT WITH SLAB-ON-GRADE OR MASONRY BLOCK FOUNDATIONS SHALL BE HOT-DIPPED GALV. AFTER FABRICATION, OR MANUF. FROM G185 OR Z450 GALV. STL CONNECTIONS SHALL BE IN ACCORDANCE WITH TABLE.

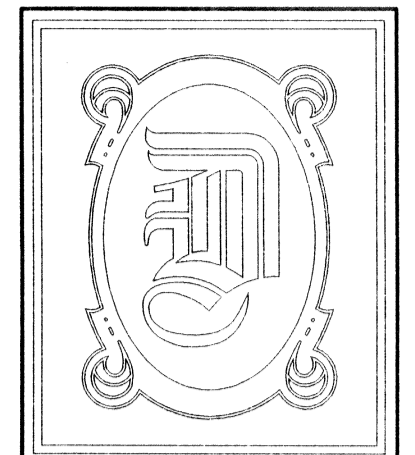
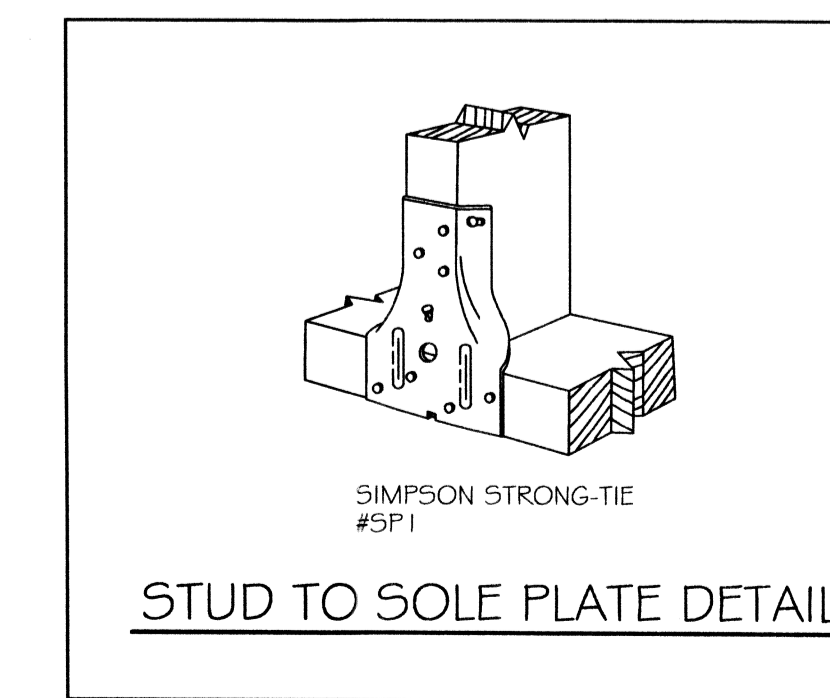
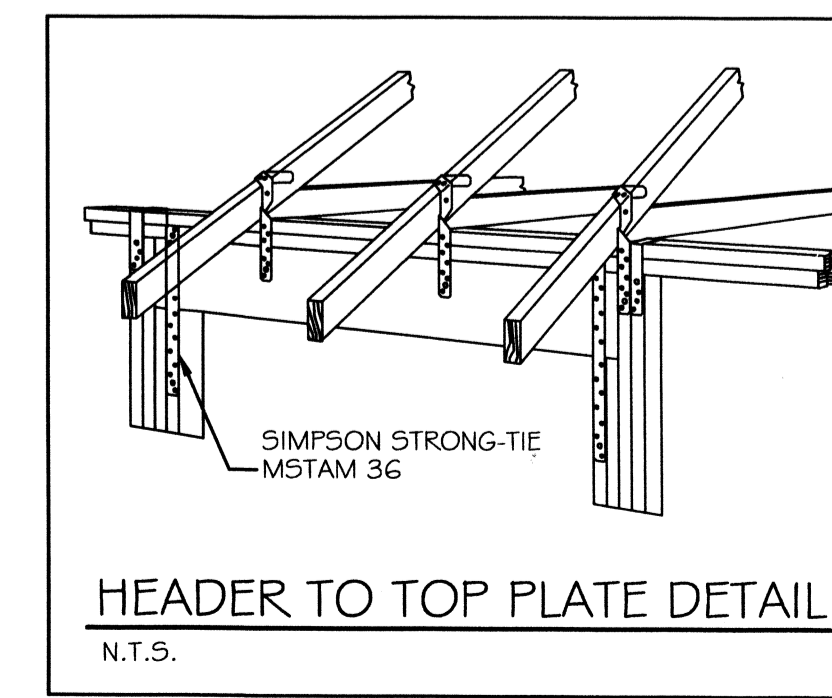
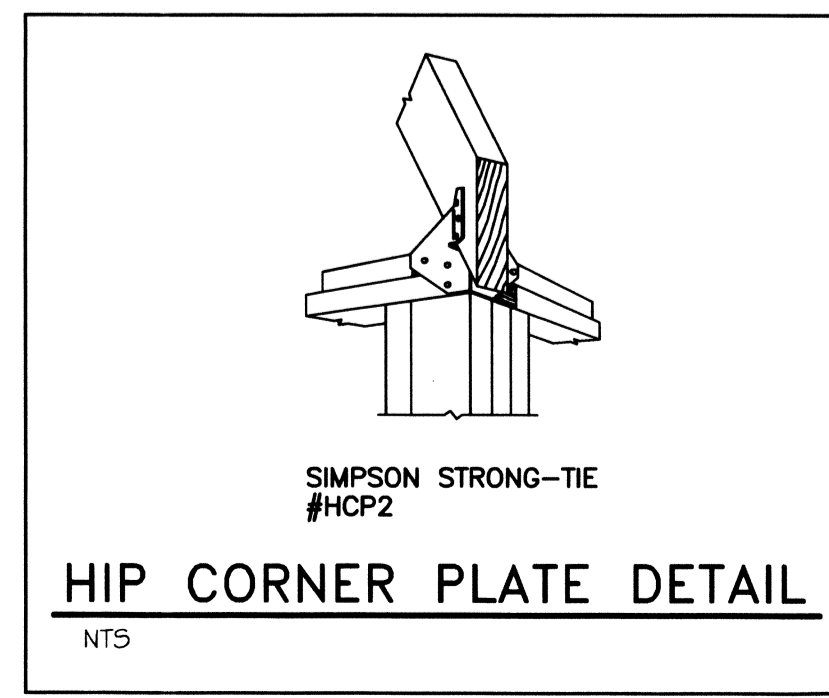
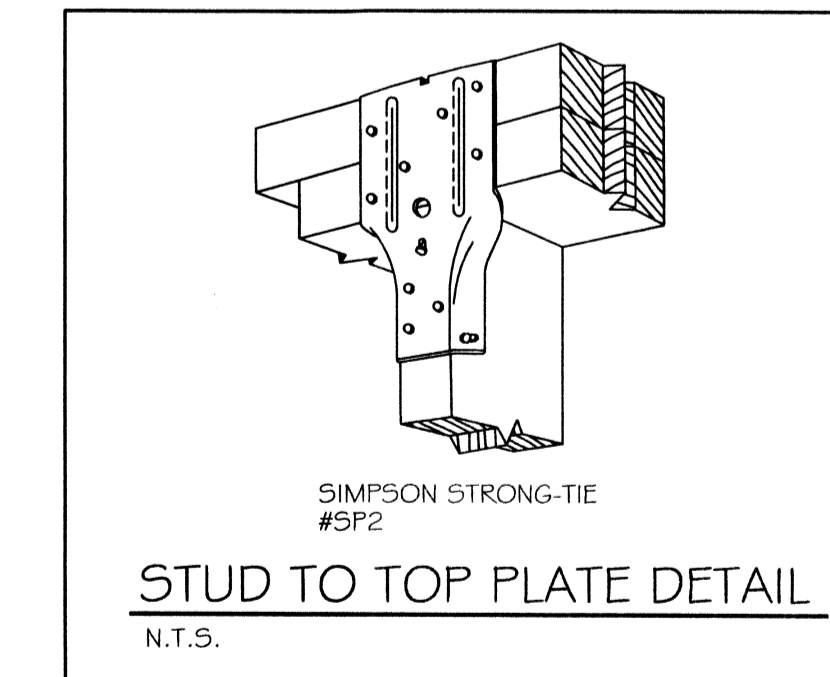
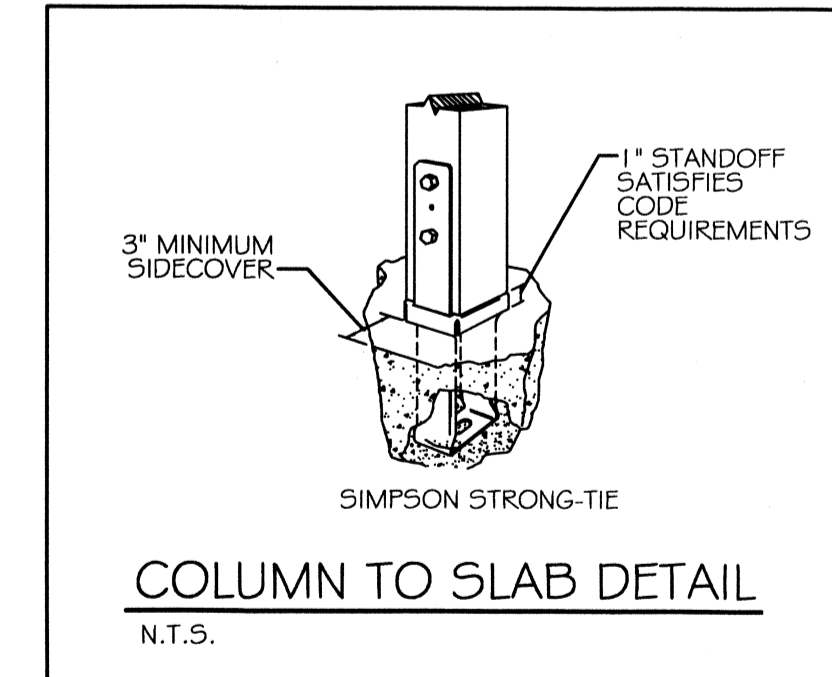
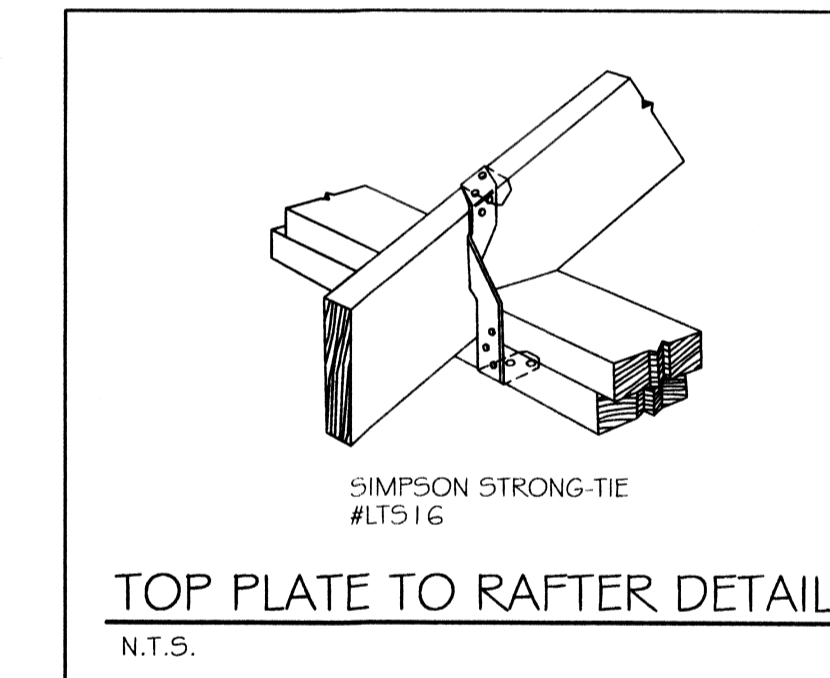
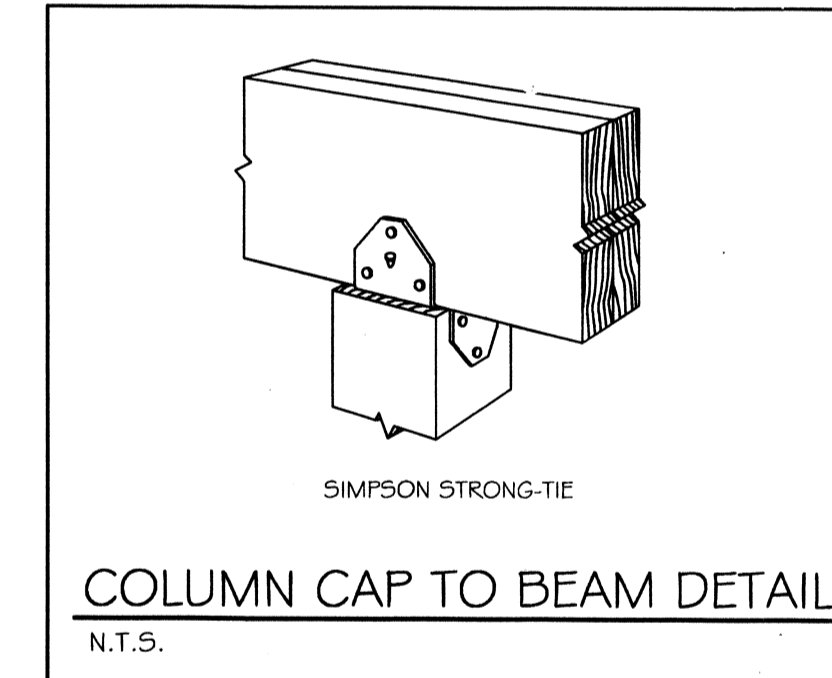
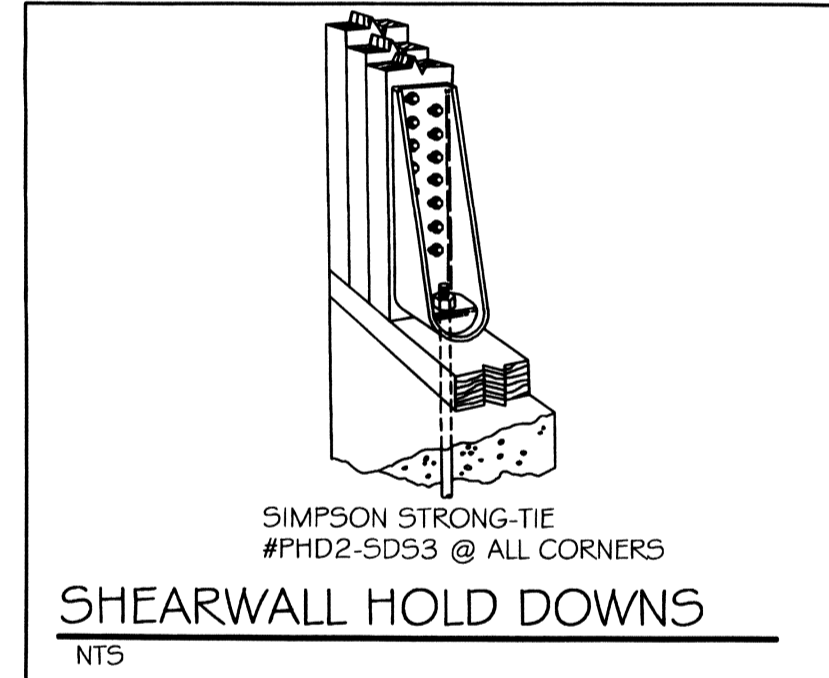
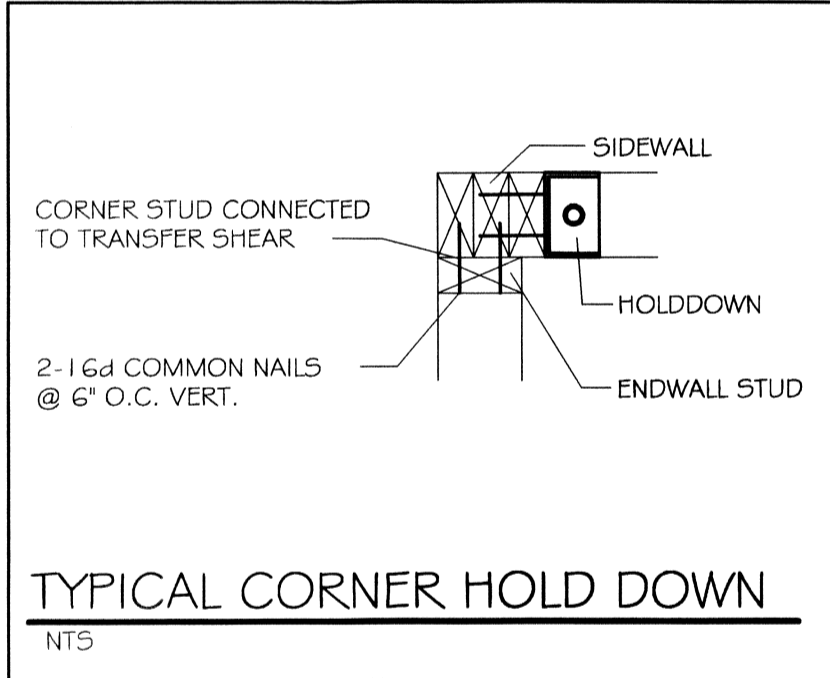
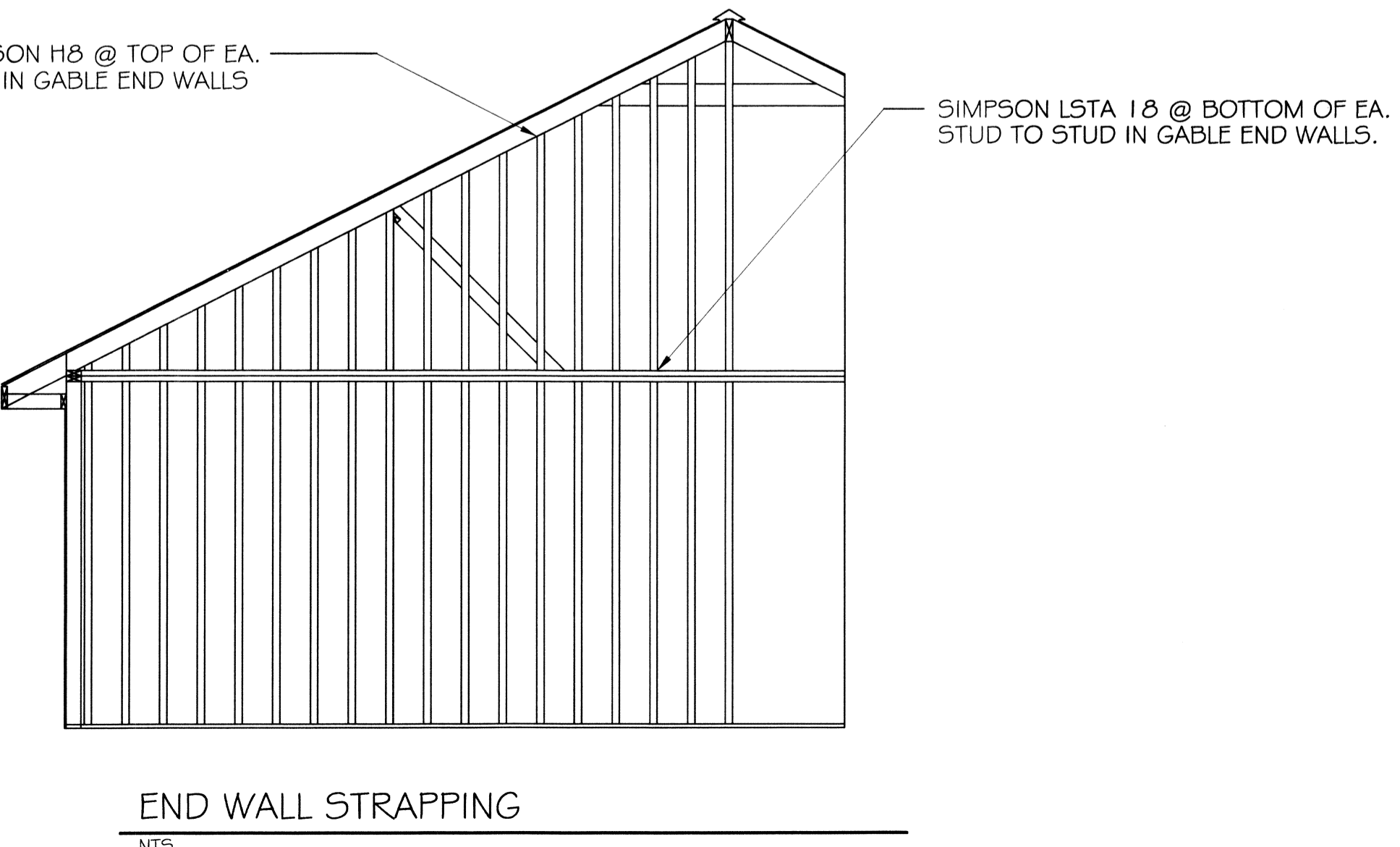

DAMMON ENGINEERING, INC.

CHIEF ENGINEER
EMMETT DAMMON, P.E.

CHIEF ARCHITECT
ROBERT WILTSE

554 OLD SPANISH TRAIL
SLIDELL, LA. 70458
OFFICE: 985-649-5832
FAX: 985-641-5950

WEBSITE:
WWW.DAMMONENGINEERING.COM

EMAIL:
DAMMONENG@BELLSOUTH.NET

- ARCHITECTURE
- ENGINEERING
- STUDIES
- PLANNING
- INVESTIGATION
- EXPERT WITNESS

NEW RESIDENTIAL COMMUNITY HOME

STARC WEST
1705 VIOLA ST
MANDEVILLE, LA

STRAPPING DETAILS & NOTES

REV: [Signature]

SCALE: AS NOTED

JOB#: 2081

DATE: 04-08-2011

SHEET 11

F-1

OF 17