

**HVAC NOTES**

1. ALL DUCTWORK SHALL BE CONSTRUCTED IN STRICT ACCORDANCE WITH SMACNA STANDARDS.
2. ALL NEW SUPPLY AIR DUCTS, RETURN AIR DUCTS, OUTSIDE AIR DUCTS AND PLENUMS SHALL BE GALVANIZED STEEL, EXTERNALLY INSULATED WITH 2" THICK 1 PCF DENSITY INSULATION WITH FOIL FACING.
3. ROUND FLEXIBLE DUCT TO BE UL-181, CLASS 1, AIR DUCT MATERIALS.
4. DUCT SIZES SHOWN ARE CLEAR INSIDE DIMENSIONS.
5. IN ALL SYSTEMS 2000 CFM AND OVER, BUT LESS THAN 15,000 CFM, SMOKE DETECTORS SHALL BE INSTALLED, IN ACCORDANCE WITH NFPA 72E & NFPA 90A, IN THE RETURN DUCT UPSTREAM OF THE AIR HANDLING UNIT AND DOWNSTREAM OF ALL FILTERS TO AUTOMATICALLY STOP THE FAN. IN ADDITION TO SMOKE DETECTOR, PROVIDE FIRESTAT CONTROL WITH FIXED CUTOFF TEMP. OF 125°F IN THE SUPPLY AIR DUCT DOWNSTREAM OF THE AIR HANDLING UNIT.
6. IF MORE THAN ONE SYSTEM IS SERVING A SHARED AREA AND THE TOTAL CFM OF THE COMBINED SYSTEMS SERVING THE SHARED AREA ARE GREATER THAN 2,000 CFM, THEN BOTH UNITS SHALL BE EQUIPPED WITH A SMOKE DETECTOR IN THE RETURN DUCT.
7. PROVIDE U.L. RATED FIRE DAMPERS WHERE REQUIRED AT ALL DUCT PENETRATIONS OF FIRE-RATED ASSEMBLIES AND WHERE REQUIRED BY CODE, INCLUDING OUTSIDE AIR INTAKES.
8. CONDENSATE DRAINS TO BE PVC PIPE RUN TO PLUMBERS P-TRAP WITHIN FIVE FEET OF AIR HANDLING UNITS.
9. ALL AIR HANDLING SYSTEMS TO BE BALANCED TO ASSURE PROPER AIR FLOWS PER PLANS.
10. ALL THERMOSTATS TO BE AUTOMATIC CHANGEOVER WITH HEAT SWITCH.
11. EXHAUST FAN EQUAL TO BROAN MODEL NO. 100 CF. OR EQUAL. FAN SHALL BE CONTROLLED BY A SWITCH ON THE WALL IN THE SAME LOCATION AS LIGHT SWITCH(S). PROVIDE BACK DRAFT DAMPER.
12. PROVIDE AND INSTALL WATER PROOF GRILLE VENT IN PROPER ROOF LOCATION FOR PLUMBING FIXTURE EXHAUST.
13. ALL SUPPLY AIR VENTS SHALL BE EQUIPPED WITH AIR CONTROL DAMPERS.
14. LOCATE OUTDOOR UNITS AS SHOWN ON ARCH. DWGS.
15. REFRIGERANT LINES SHALL BE SIZED BY UNIT MANUFACTURER AND INSTALLED ACCORDING TO MANUFACTURER'S INSTRUCTIONS.
16. FRESH AIR SHALL BE SUPPLIED TO EACH AIR HANDLER THROUGH EXTERIOR WALL DUCT SUPPLIED WITH A CONTROL DAMPER.
17. INSTALL FIRE DAMPER WHERE S.A. & R.A. DUCTS PENETRATE 1 HOUR RATED CEILING.
18. ALL ELECTRICAL, MECHANICAL, AND PLUMBING PENETRATING FIRE WALLS SHALL BE FIRE CAULKED. (PENETRATIONS THROUGH RATED CONSTRUCTION SHALL BE SEALED WITH A MATERIAL CAPABLE OF PREVENTING THE PASSAGE OF FLAMES AND HOT GASES WHEN TESTED IN ACCORDANCE WITH ASTM-E8-14).
19. ALL MECHANICAL SYMBOLS ARE DRAWN DIAGRAMMATICALLY, CONTRACTOR TO VERIFY WITH OWNER LOCATIONS OF VENTS, DAMPERS, REGISTERS, ETC.
20. REFER TO STRUCTURAL DRAWINGS TO COORDINATE LOCATION(S) & MOUNTING OF MECHANICAL EQUIPMENT.
21. FLEXIBLE DUCTWORK LENGTH NOT TO EXCEED 10'-0".
22. REFER TO REFLECTED CEILING PLAN FOR FINAL GRILLE AND DIFFUSER LOCATIONS AND COORDINATE AS REQUIRED.
23. FINAL LOCATION OF TEMPERATURE CONTROLS TO BE COORDINATED WITH OWNER AT JOB SITE.
24. PROVIDE AND INSTALL SMOKE DETECTORS AS APPROVED BY LOCAL AHJ'S. PLACE NEAR R/A AND S/A OPENINGS OF AHU AND PROVIDE, WITH ACCESS PANEL, WIRING BY ELECTRICAL CONTRACTOR.
25. FRESH AIR INTAKES ARE REQUIRED TO HAVE MOTORIZED OR GRAVITY DAMPERS TO SHUT OFF WHEN SYSTEM IS NOT RUNNING. ALL THERMOSTATS MUST BE PROGRAMMABLE. SEE SECTIONS 502.4.4 OR 503.2.4.3 OF THE 2006 INTERNATIONAL ENERGY CODE.

**STARC WEST HVAC CALCULATIONS**

Wed October 13, 2010

**Zone 1**  
 The Btuh Gain for 90 SqFt of East and West Double Pane Glass = 8550  
 The Btuh Gain for 18 SqFt of South Double Pane Glass = 1260  
 The Btuh Gain for 1250 SqFt of Wood Stud, R-13, # 5/8" Gypsum Wall = 2875  
 The Btuh Gain for 2150 SqFt of Roof Only 8" - 9.5" R-30; Ceiling = 6880  
 The Btuh Gain for 6 People = 60  
 The Btuh Gain for 2150 SqFt of Area Lighting in an Office = 6450

**Fresh Air Calculations:** (per the 2007 supplement to the IMC Section 403.3.1.1)  
 $Vbz = RpPz + RaAz$   
 $(5 * 6) + (0.06 * 2150) = 160$  cfm of fresh air  
 The Btuh Gain for Outside Fresh Air = 7200

The Total BTU/h Gain = 33275  
 The Total Tons of HVAC needed = 2.773  
 Electric Heat Required = 9.729 kW

**Zone 2**  
 The Btuh Gain for 72 SqFt of North and Shaded Double Pane Glass = 960  
 The Btuh Gain for 48 SqFt of South Double Pane Glass = 1260  
 The Btuh Gain for 1290 SqFt of Wood Stud, R-13, # 5/8" Gypsum Wall = 2967  
 The Btuh Gain for 1700 SqFt of Roof Only 8" - 9.5" R-30; Ceiling = 5440  
 The Btuh Gain for 20 People = 200  
 The Btuh Gain for 1700 SqFt of Area Lighting in an Office = 5100

**Fresh Air Calculations:** (per the 2007 supplement to the IMC Section 403.3.1.1)  
 $Vbz = RpPz + RaAz$   
 $(5 * 20) + (0.06 * 1290) = 180$  cfm of fresh air  
 The Btuh Gain for Outside Fresh Air = 8100

The Total BTU/h Gain = 24027  
 The Total Tons of HVAC needed = 2.002  
 Electric Heat Required = 7.025 kW

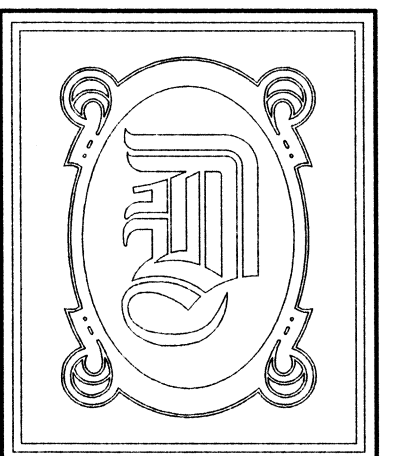
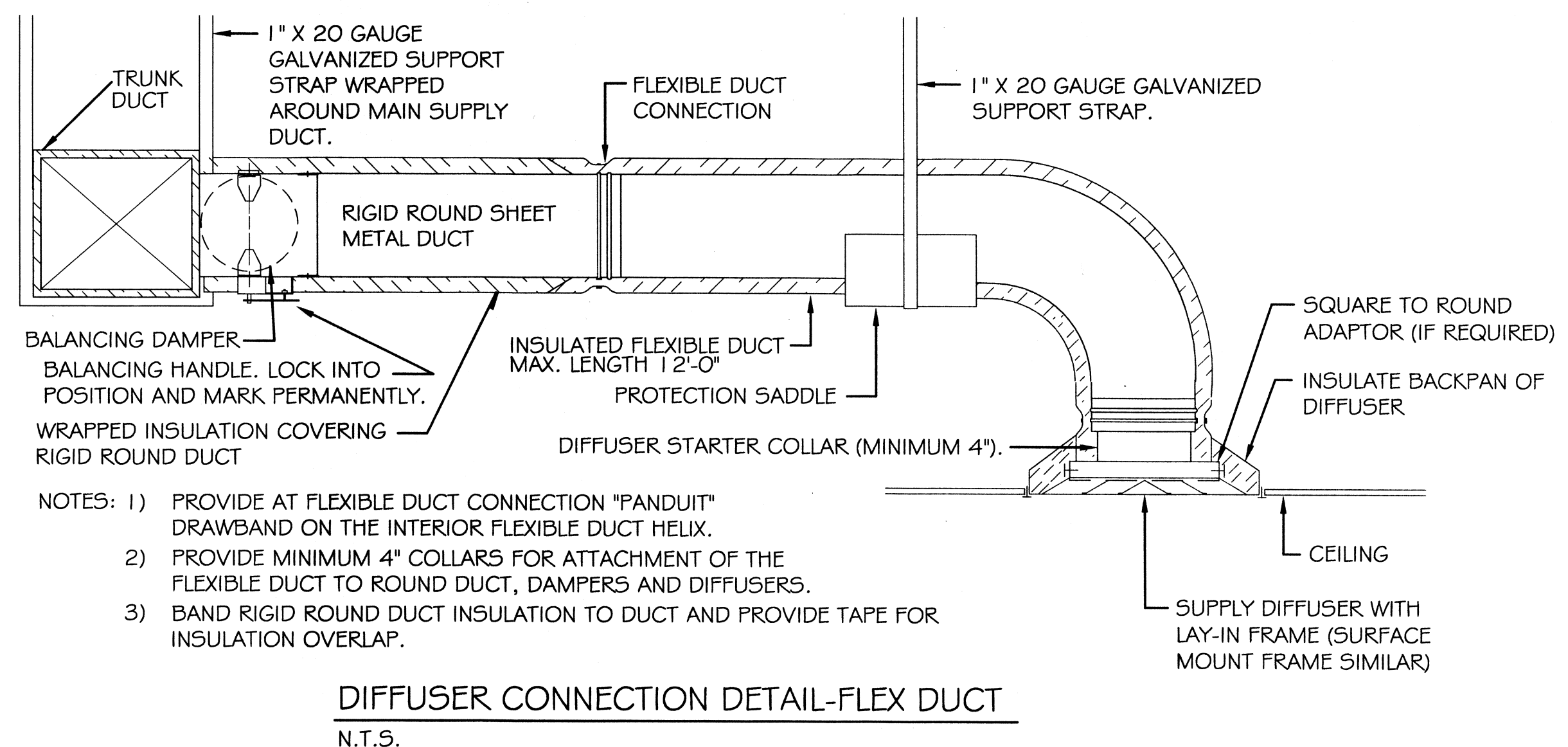
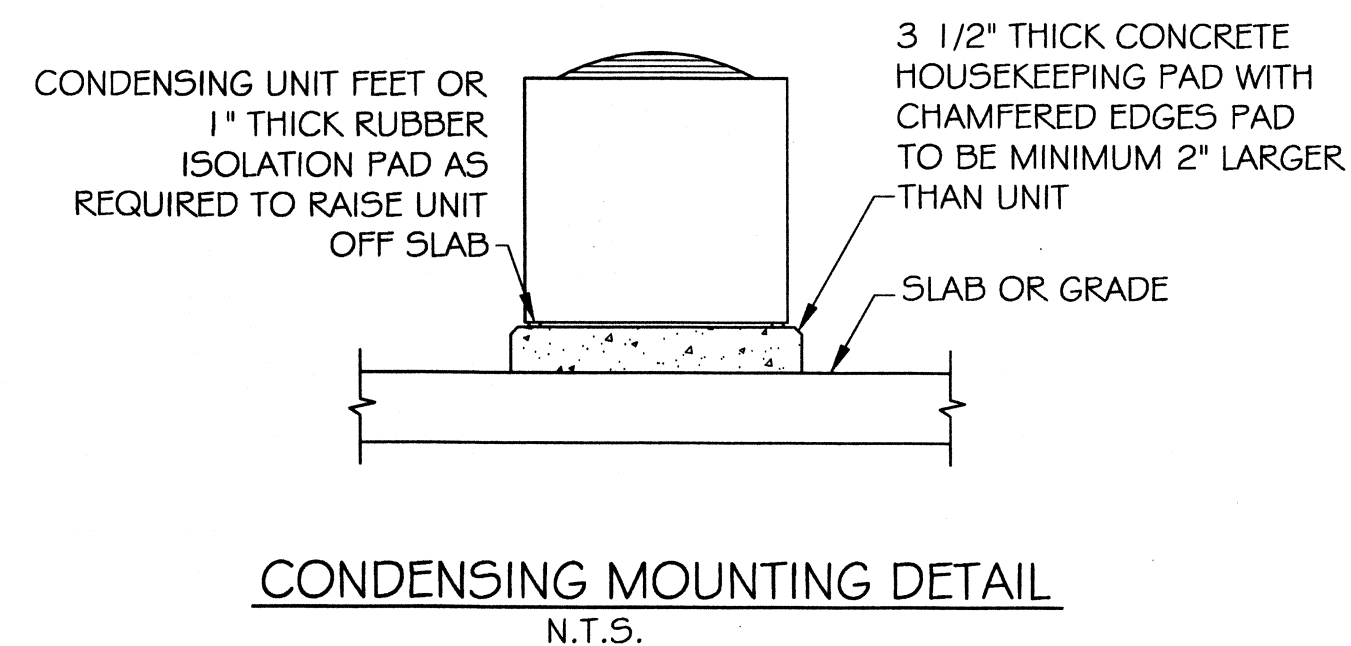
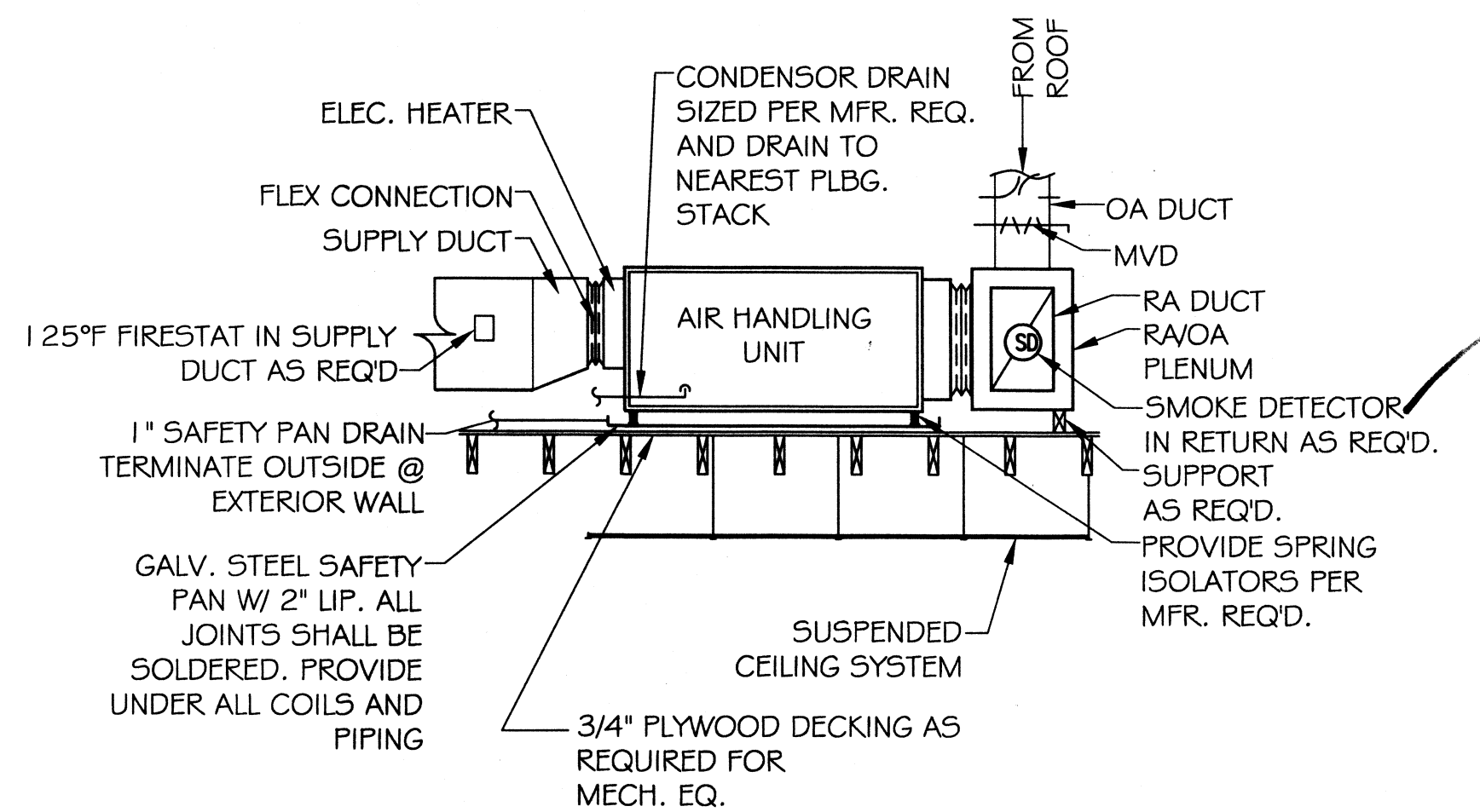
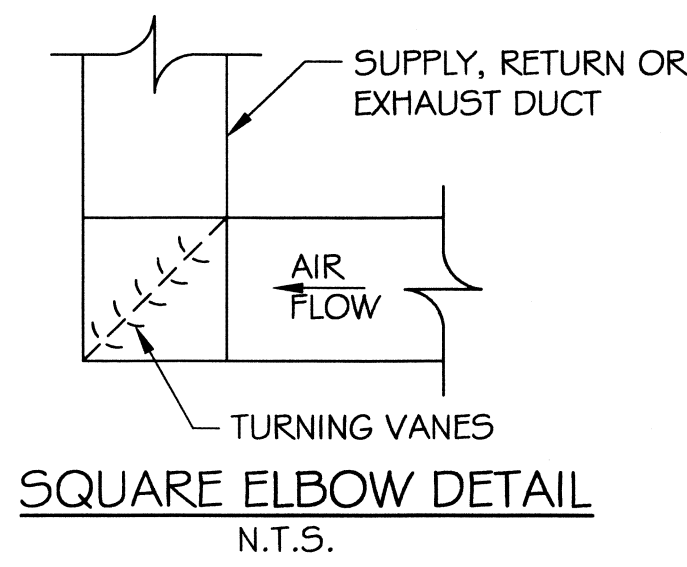
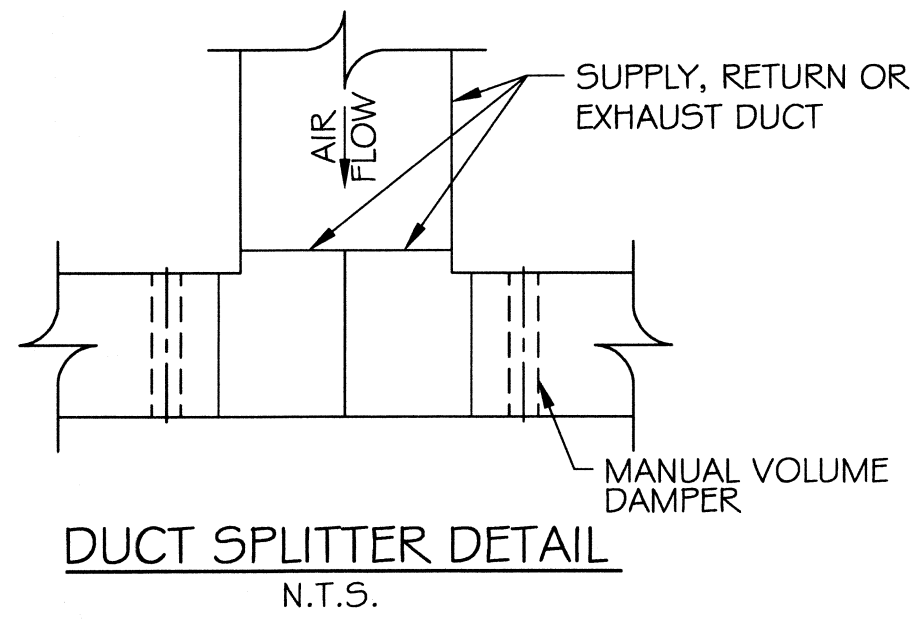
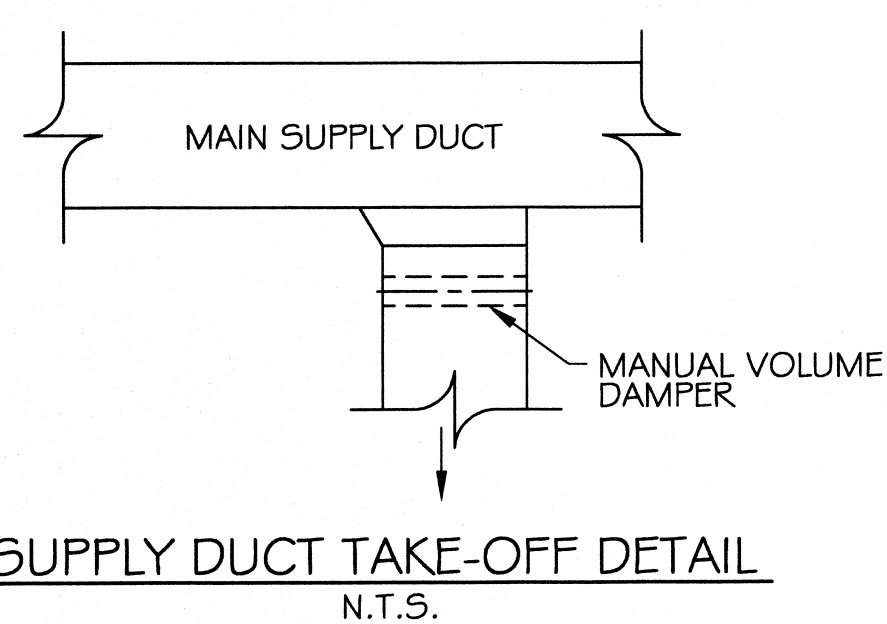

**DAMMON ENGINEERING, INC.**

CHIEF ENGINEER  
EMMETT DAMMON, P.E.

CHIEF ARCHITECT  
ROBERT WILTSE

1095 FLORIDA AVENUE  
SLIDELL, LA. 70458  
OFFICE: 985-649-5832  
FAX: 985-641-5950

WEBSITE:  
WWW.DAMMONENGINEERING.COM

EMAIL:  
DAMMONENG@BELLSOUTH.NET

- ARCHITECTURE
- ENGINEERING
- STUDIES
- PLANNING
- INVESTIGATION
- EXPERT WITNESS

**NEW RESIDENTIAL COMMUNITY HOME**

STARC WEST  
1705 VIOLA ST  
MANDEVILLE, LA

**MECHANICAL NOTES**

Robert Wiltse

REV:

SCALE: AS NOTED

JOB#: 2081

DATE: 11-4-10

SHEET 13

**M-2**