

- CHASEWAYS NOTES**
1. SLOPE CHASEWAYS TO DRAIN INTO TRENCH
  2. 90° BENDS IN CHASEWAYS SHALL BE MADE USING "SWEEP" ELBOWS OR TWO (2) 45° ELBOWS OR "SWEEP" TEE WHEN APPLICABLE.

NO.	CHASEWAY SCHEDULE		
A	4" PVC PIPE	ROLLER UP	PNEUMATIC
B	4" PVC PIPE	FLOOR SWITCH	ELECTRIC
C	4" PVC PIPE	CIA	CHEMICAL DISTRIBUTION
D	4" PVC PIPE	SPARE	CHEMICAL
E	4" PVC PIPE	CONVEYOR	HYDRAULIC
F	4" PVC PIPE	CONVEYOR	HYDRAULIC
G	4" PVC PIPE	CONVEYOR	HYDRAULIC
H	2" PVC PIPE	ANTI COLLISION BOX	ELECTRIC

**TYPICAL CHASEWAY INSTALLATION DETAIL**  
N.T.S.

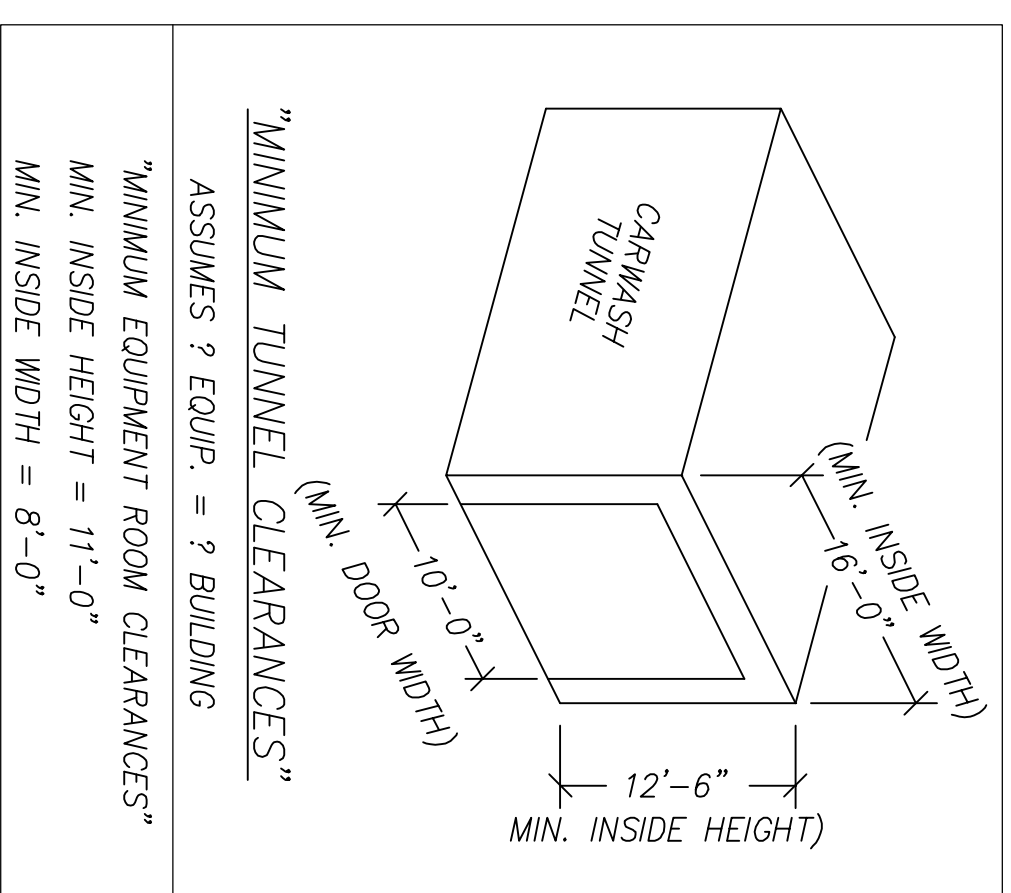
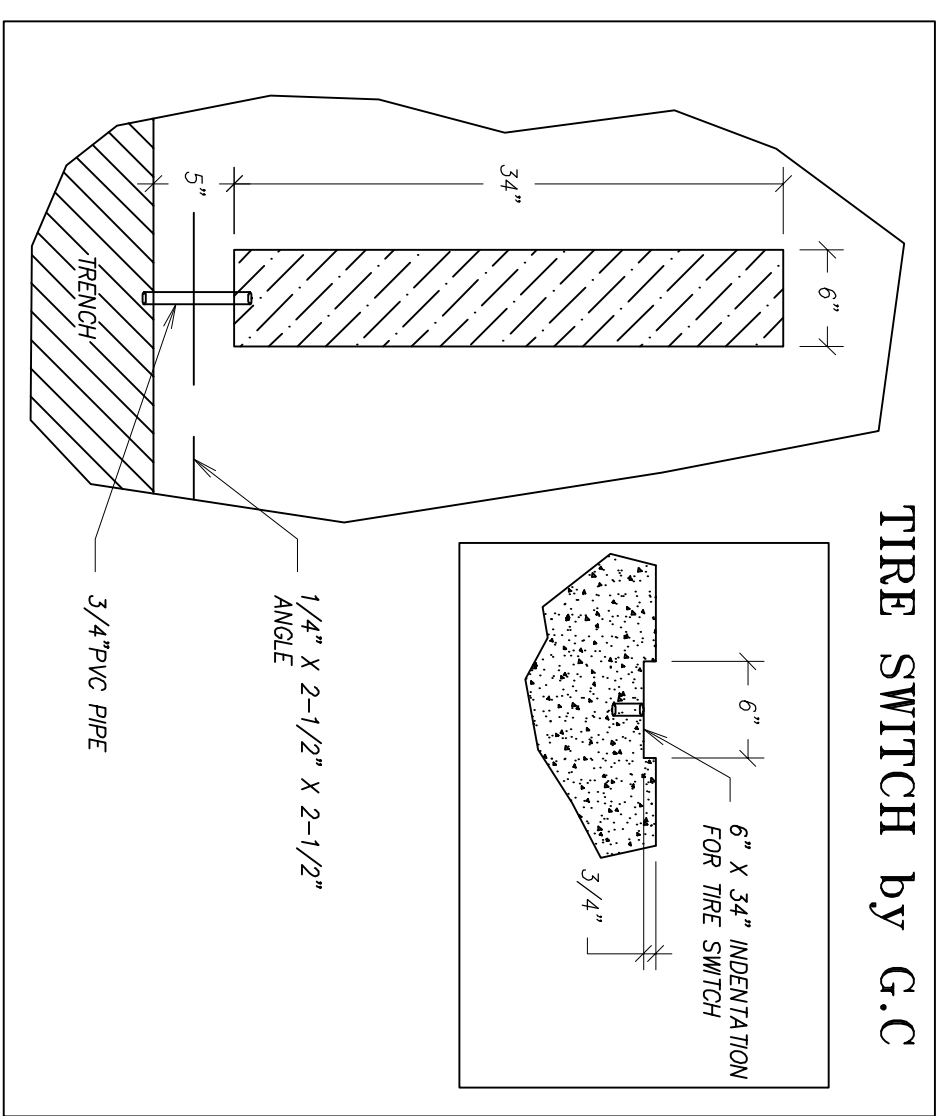

"MINIMUM TUNNEL CLEARANCES"  
ASSUMES ? EQUIP. = ? BUILDING  
"MINIMUM EQUIPMENT ROOM CLEARANCES"  
MIN. INSIDE HEIGHT = 11'-0"  
MIN. INSIDE WIDTH = 8'-0"

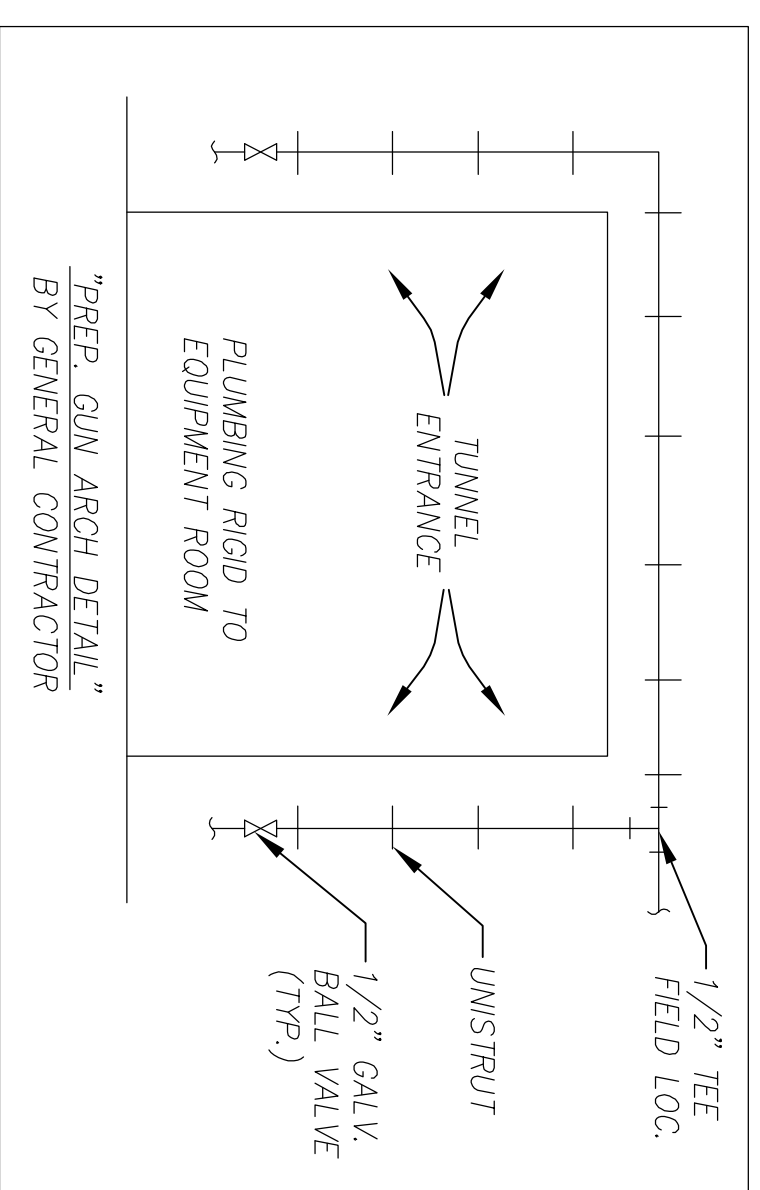
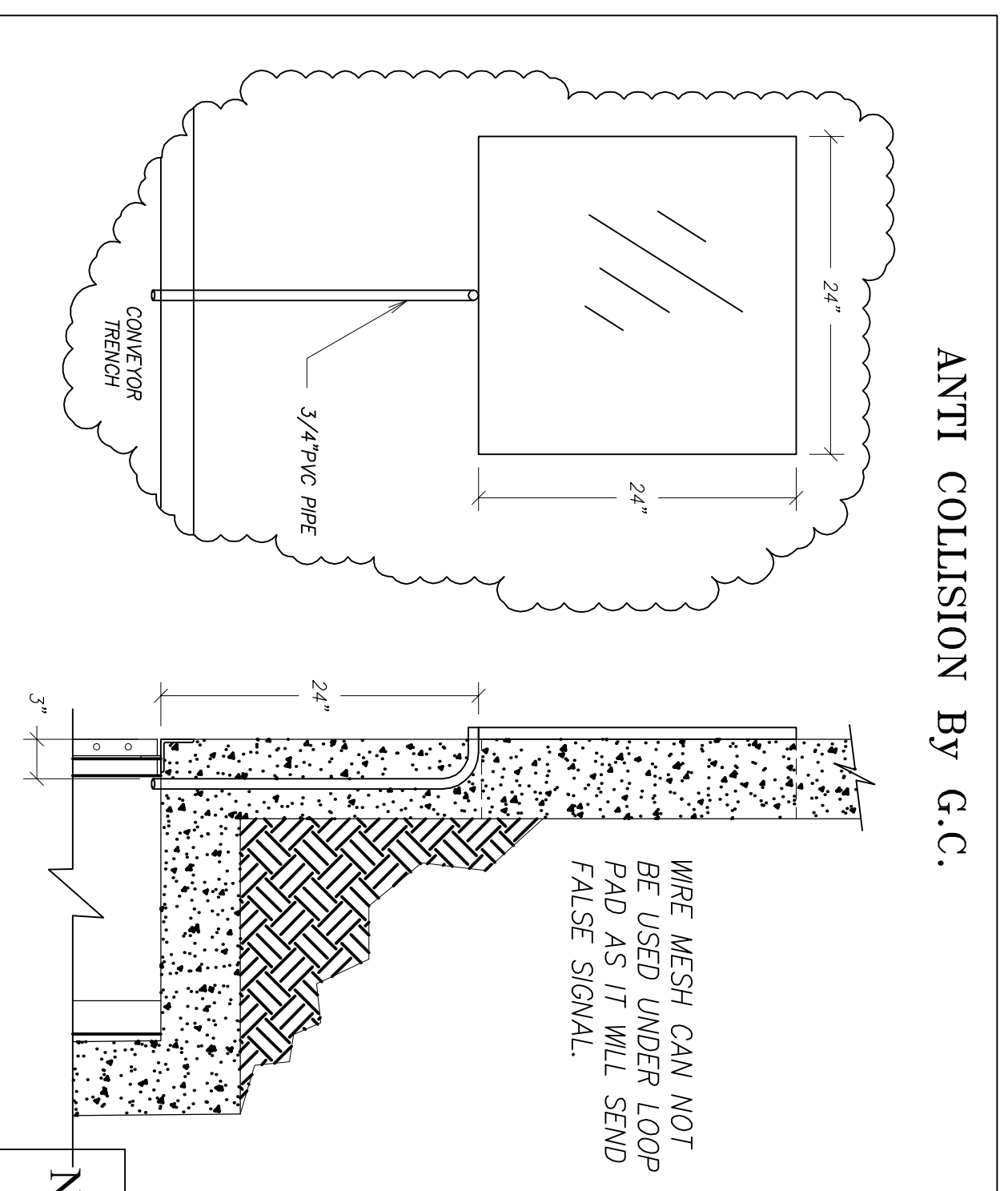

NOT FOR CONSTRUCTION UNTIL APPROVED BELOW.

APPROVED BY: \_\_\_\_\_ DATE: \_\_\_\_\_

**DISCLAIMER**  
ALTHOUGH BUILDING CODES HAVE BEEN CONSIDERED IN DEVELOPING THIS DRAWING, VERIFICATION OF SITE SPECIFIC CONDITIONS AND COMPLIANCE WITH FEDERAL, STATE AND LOCAL BUILDING CODES IS THE EXCLUSIVE RESPONSIBILITY OF THE CUSTOMER AND/OR ARCHITECT AND ENGINEER.  
THESE DRAWINGS REFLECT REQUIREMENTS FOR SONNY'S FURNISHED EQUIPMENT ONLY UNLESS OTHERWISE NOTED. PLEASE REFER TO OTHER MANUFACTURERS, IF ANY, FOR THEIR EQUIPMENT REQUIREMENTS.

**CONFIDENTIAL WARNING:**  
THIS SHEET CONTAINS AND CONSTITUTES CONFIDENTIAL INFORMATION, IMAGES AND TRADE SECRETS OF SONNY'S ENTERPRISES INC. ANY UNAUTHORIZED USE OR DISCLOSURE OF ANY OR PORTION THEREOF IS STRICTLY PROHIBITED. THIS WORK IS THE EXCLUSIVE PROPERTY OF SONNY'S ENTERPRISES INC. ALL RIGHTS RESERVED.

**CWP-06370-B11-RAINFOREST-HATT.**  
SCALE: N.T.S. LOCATION: LA

Sheet 16 Rev. 1

**LEGEND**



DATE:	11.06.06
REVISION DATE:	06.18.13
CREATED BY:	LV
REVISED BY:	JCH
CHECKED BY:	Luis V.