

FILE NAME: C:\Users\jdammon\OneDrive\Documents\2022\2101 - Piling Plan.dwg
 PLOT DATE: 09/15/2022 11:42 AM
 PLOT SCALE: 1/4" = 1'-0"
 PLOT SIZE: 24.00 x 36.00
 PLOT DEVICE: HP DesignJet 5000 Series
 PLOTTER: HP DesignJet 5000 Series

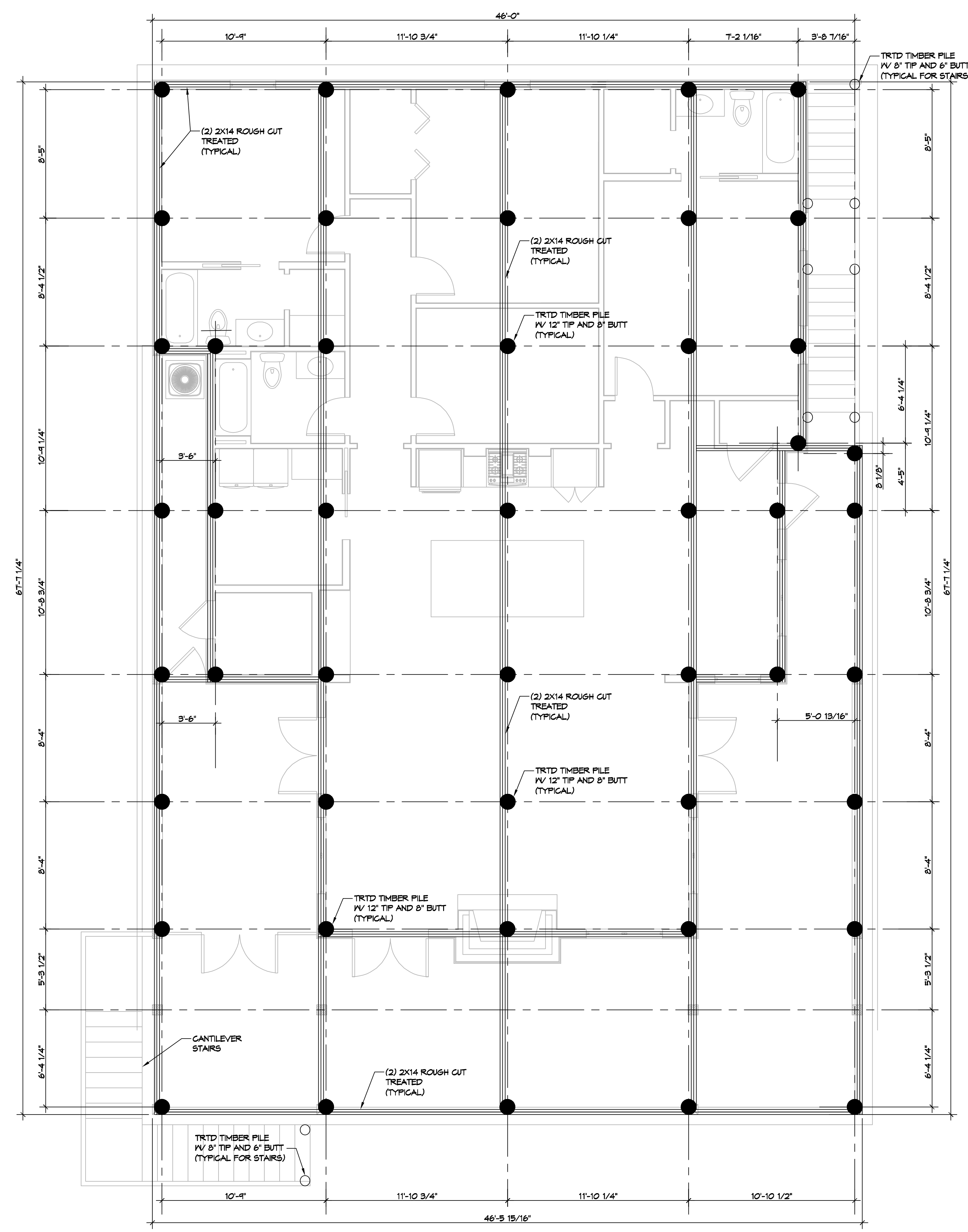

1 PILING PLAN
SCALE: 1/4" = 1'-0"

PILING NOTES

1. PILES ARE TO BE 50 FT. IN LENGTH WITH A 8 INCH TIP AND 12" BUTT. DRIVEN TO REFUSAL.
2. ALL PILES SHALL BE PRESSURE-TREATED ROUND TIMBER PILES CONFORMING TO ASTM D25.
3. DESIGN LOAD = 5 TONS PER PILE.
4. NO FIELD SUPERVISION OR INSPECTION PROVIDED UNDER THIS SEAL UNLESS OTHERWISE NOTED.
5. PILE LAYOUT MAY BE MODIFIED DUE TO ACTUAL DRIVING CONDITIONS. ENGINEER TO BE NOTIFIED ON ANY MODIFICATION.
6. A PILE BLOW COUNT LOG OF ALL PILES IS TO BE SUBMITTED TO THE ENGINEER OF RECORD. FAILURE TO SUBMIT SAID LOG WILL RELEASE THE ENGINEER OF ALL RESPONSIBILITY.
7. CONTRACTOR IS RESPONSIBLE FOR THE COMPARISON & VERIFICATION OF PILE LAYOUT DIMENSIONS WITH MOST RECENT ARCHITECTURAL DRAWINGS, ASSURING THAT PILES DO FALL WITHIN LIMITS OF THE DESIGN.
8. USE DROP HAMMER OR SINGLE ACTING AIR HAMMER DELIVERING 1500 FT-LBS OF ENERGY PER BLOW. RAM WEIGHT OF DROP HAMMER SHALL NOT EXCEED 2500 TO 3000 LBS AND THE DROP SHOULD NOT EXCEED 3 FT. AT MINIMUM OF 25 BLOWS PER FOOT. IF THE DROP EXCEEDS 3 FT., CONTACT ENGINEER FOR INSTRUCTIONS.
9. BRACE ALL PILING AS NEEDED FOR SWAYING.
10. FIELD VERIFY DIMENSIONS AGAINST THE ARCHITECTURAL DRAWINGS.

GENERAL NOTES

1. ALL LUMBER SHALL BE PRESSURE TREATED WITH A RETENTION OF .4 PER C.F.
2. ALL FASTENERS SHALL BE HOT DIPPED GALVANIZED (HDS) PER ASTM A153.
3. ALL CONNECTORS SHALL BE HDG PER ASTM A653, CLASS 6185 SHEET WITH 1.85 OZ/SF ZINC COATING.

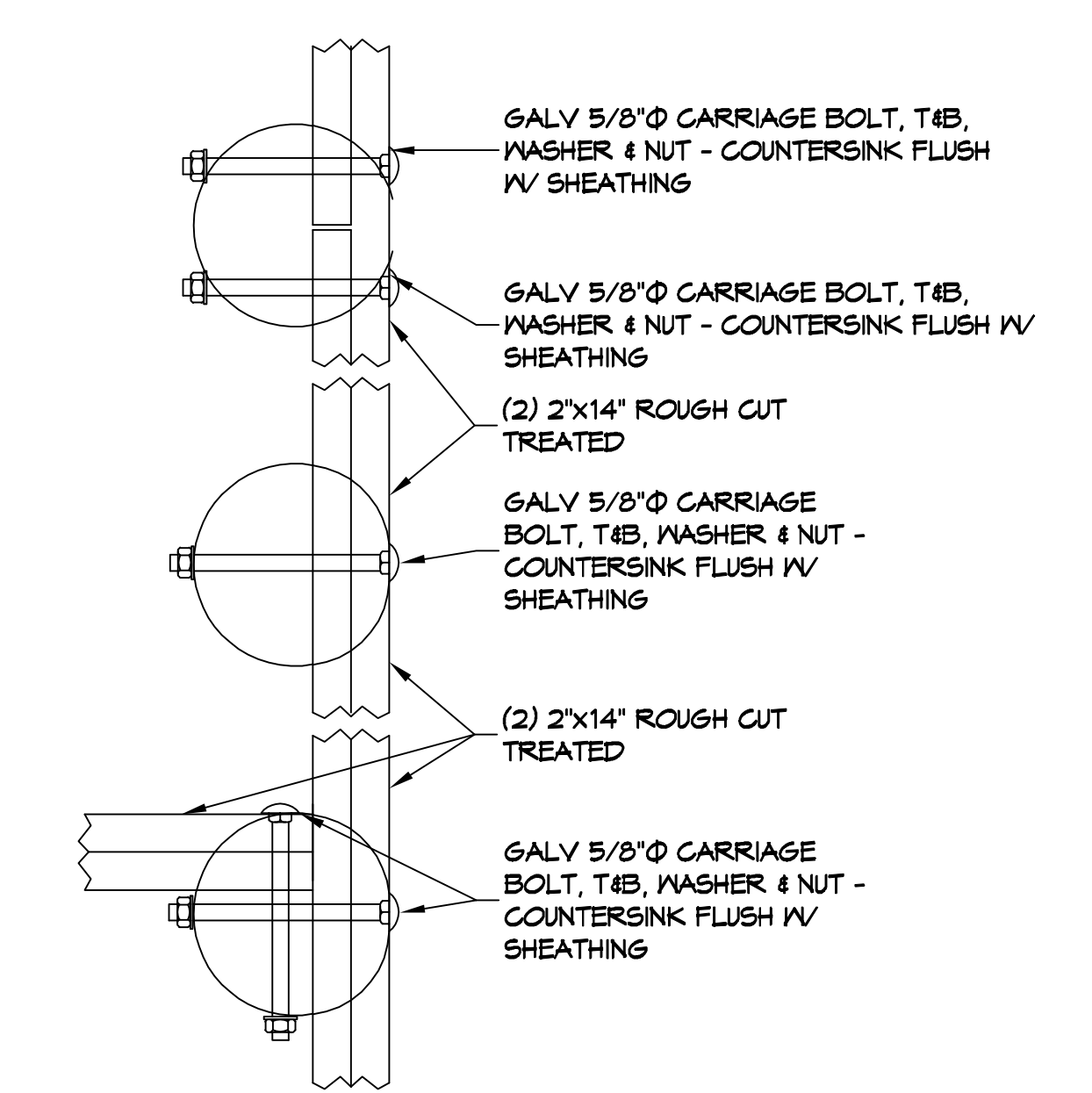

DETAIL
SCALE: 1-1/2" = 1'-0"

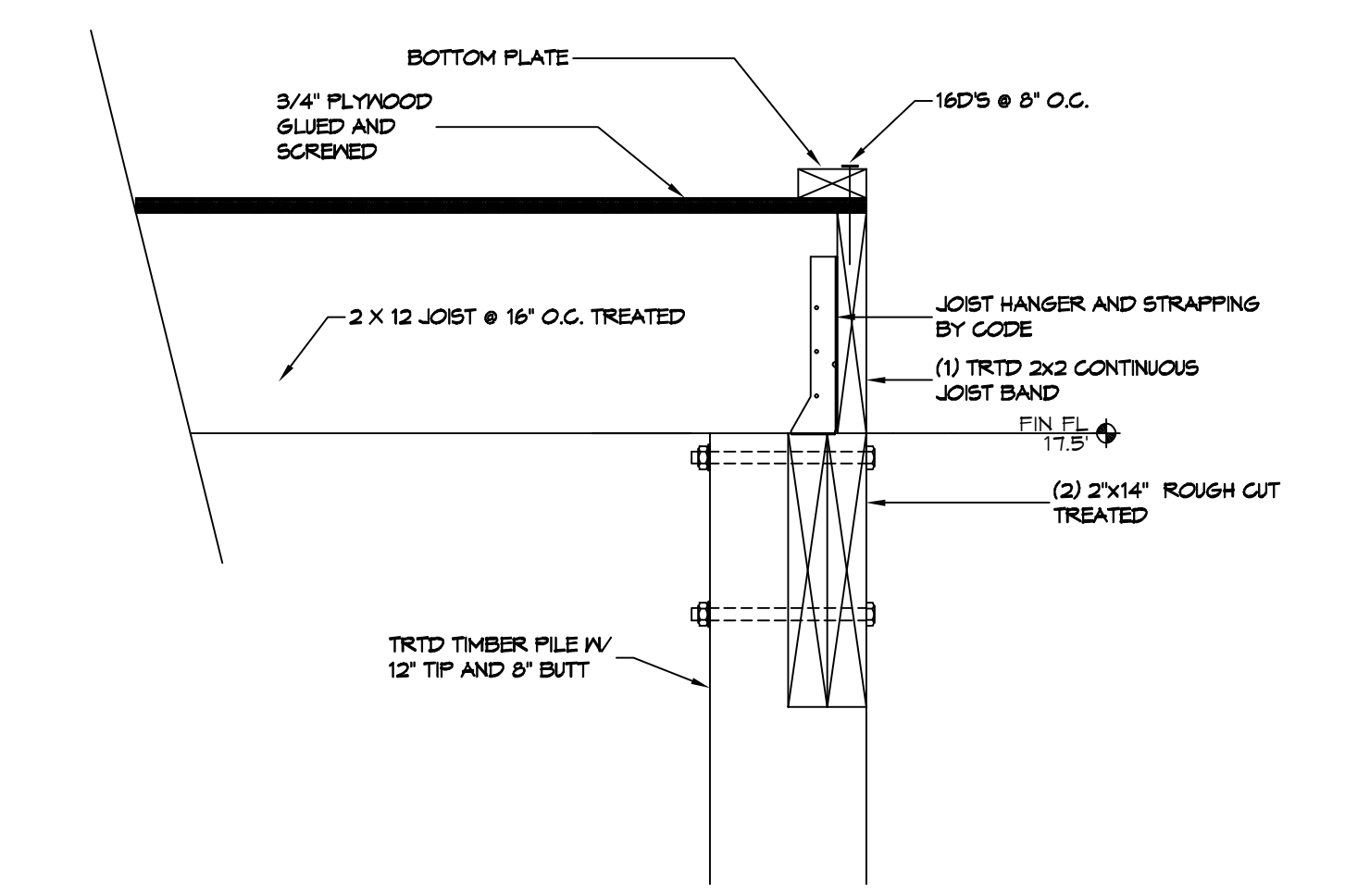

DETAIL
SCALE: 1-1/2" = 1'-0"

DAMMON ENGINEERING, INC.
 LOUISIANA & MISSISSIPPI
 Chief Engineer: Brian Misch, PE
 554 Old Spanish Trail
 Slidell, LA 70458
 www.dammonengineering.com
 info@dammonengineering.com
 PH: 985.649.8822

REVISIONS	DATE
#	DESCRIPTION

SEAL:

STRUCTURAL DWGS
JIM SMITH
 LOT 1 SQUARE 1
 22190 CHEF MENTEUR HWY US 90
 NEW ORLEANS LA 70121
 JOB No: 2021 DATE: 09-15-2022
 DRAWN BY: CKD CHECKED BY: BAM

SHEET TITLE:
PILING PLAN

DRAWING NUMBER:
S101

