

7 INTERIOR ELEVATION - GEAR ROOM
SCALE: 1/2" = 1'-0"

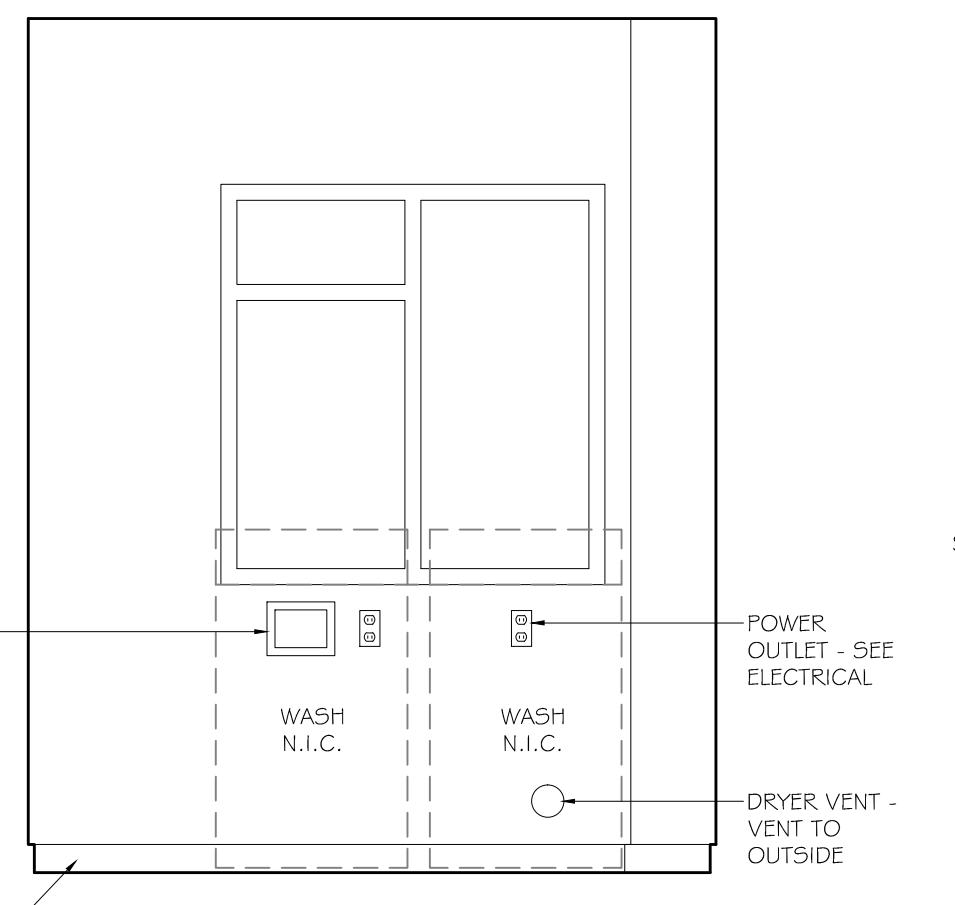

6 INTERIOR ELEVATION - UTILITY ROOM
SCALE: 1/2" = 1'-0"

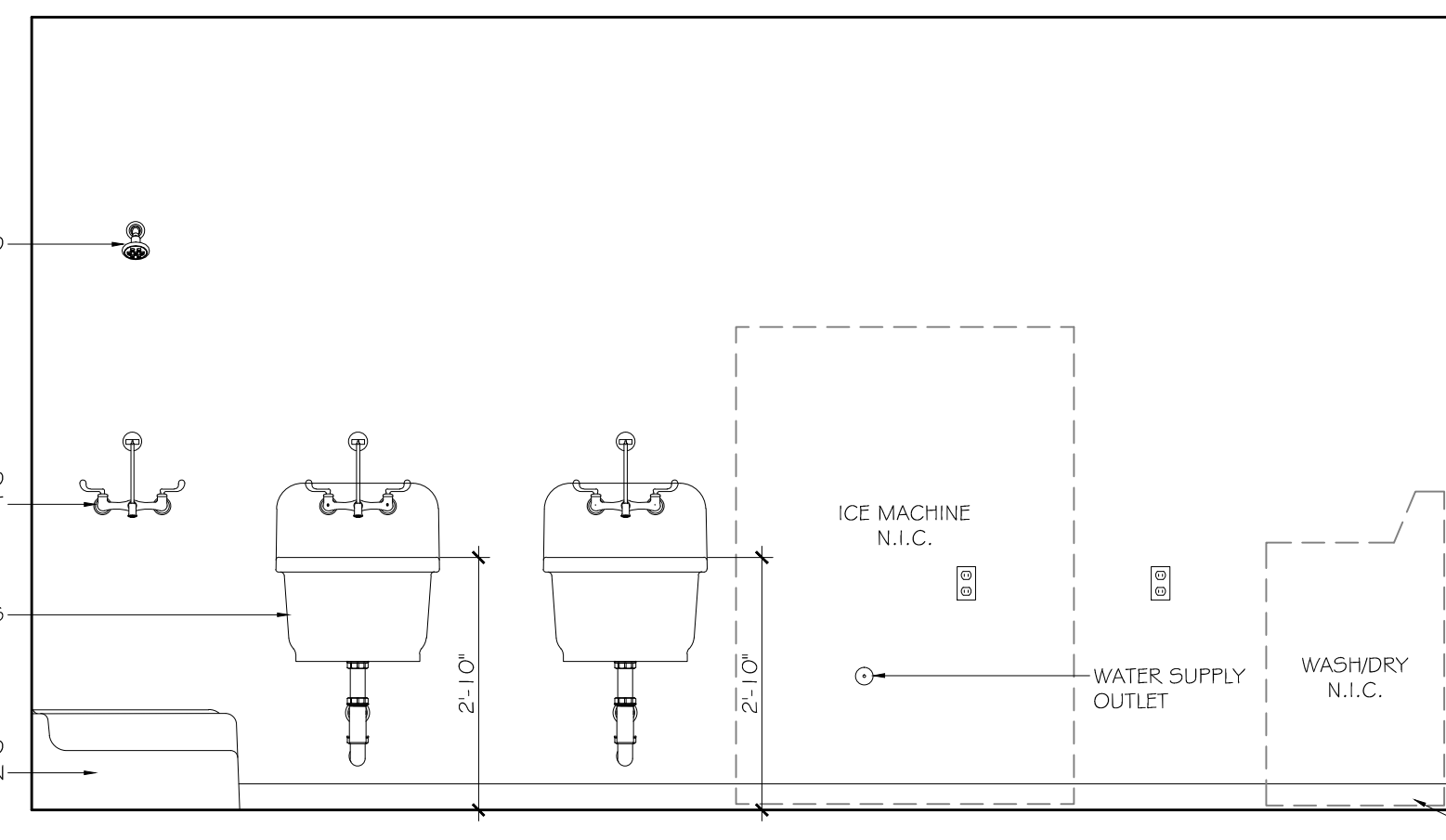

5 INTERIOR ELEVATION - UTILITY ROOM
SCALE: 1/2" = 1'-0"

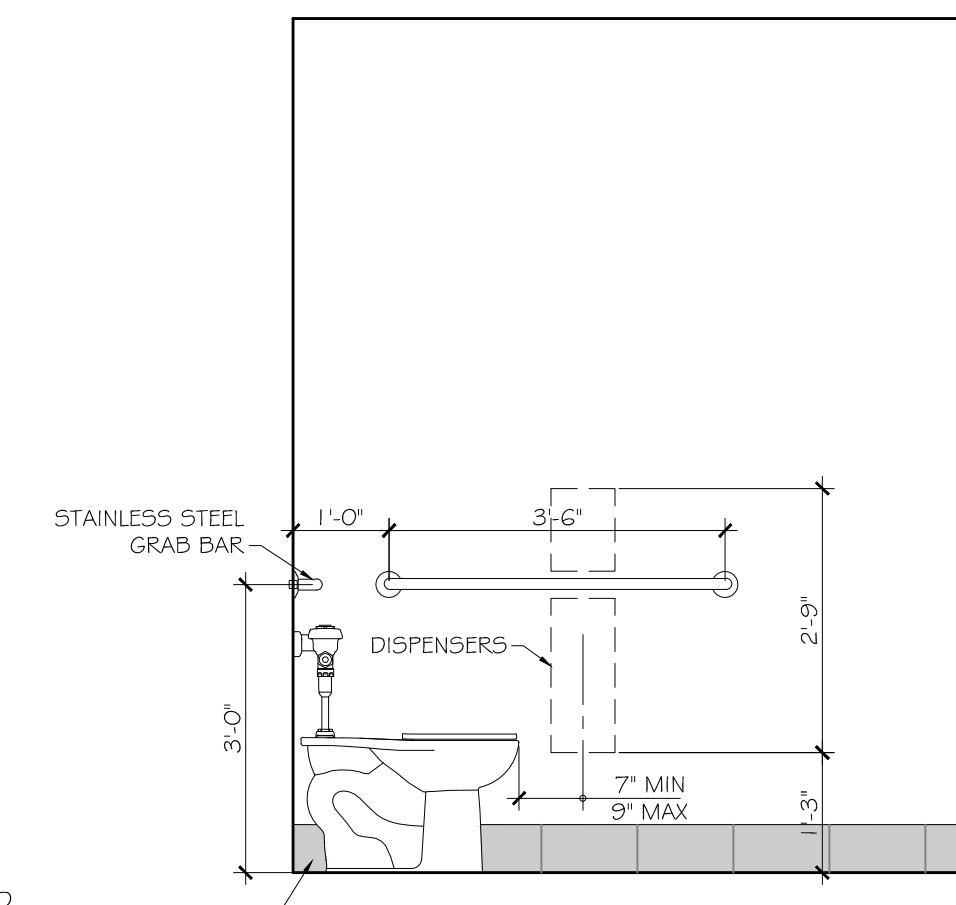

4 INTERIOR ELEVATION - REST ROOM
SCALE: 1/2" = 1'-0"

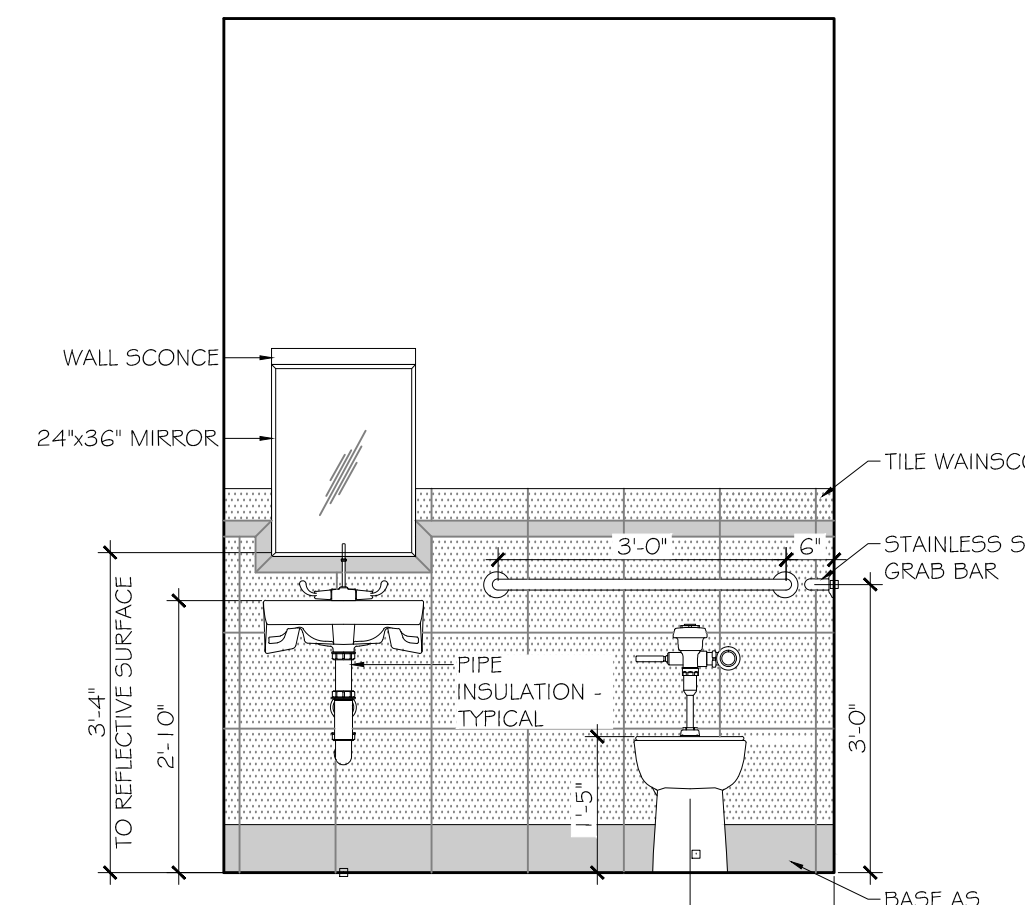

3 INTERIOR ELEVATION - REST ROOM
SCALE: 1/2" = 1'-0"

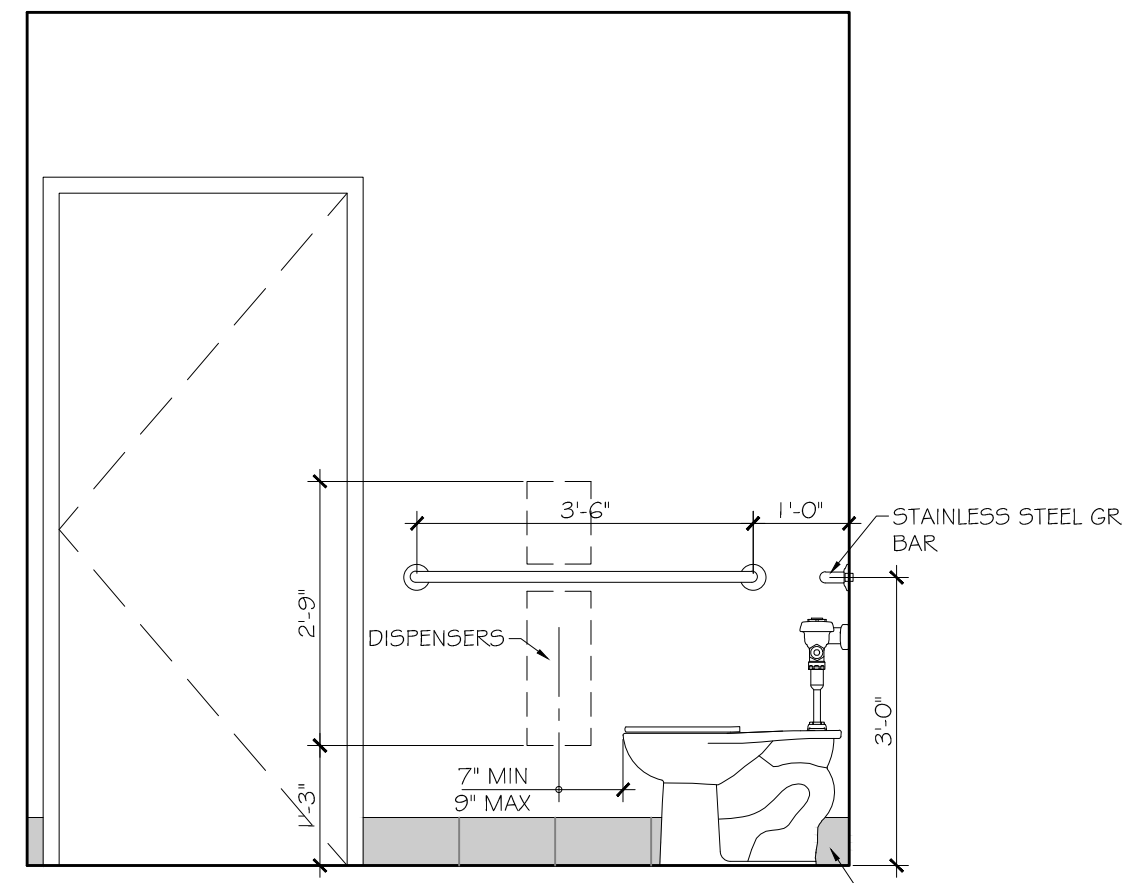

2 INTERIOR ELEVATION - WOMEN'S TOILET
SCALE: 1/2" = 1'-0"

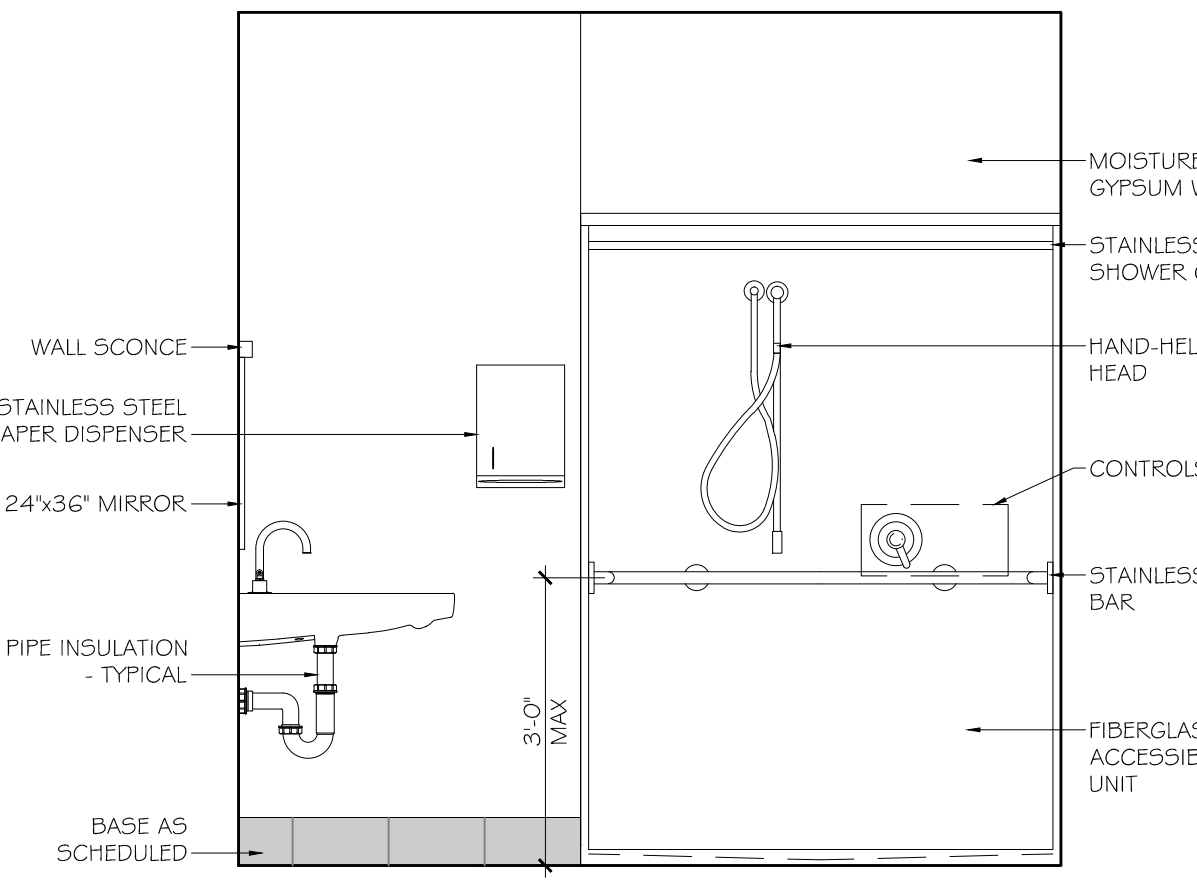

1 INTERIOR ELEVATION - WOMEN'S TOILET
SCALE: 1/2" = 1'-0"

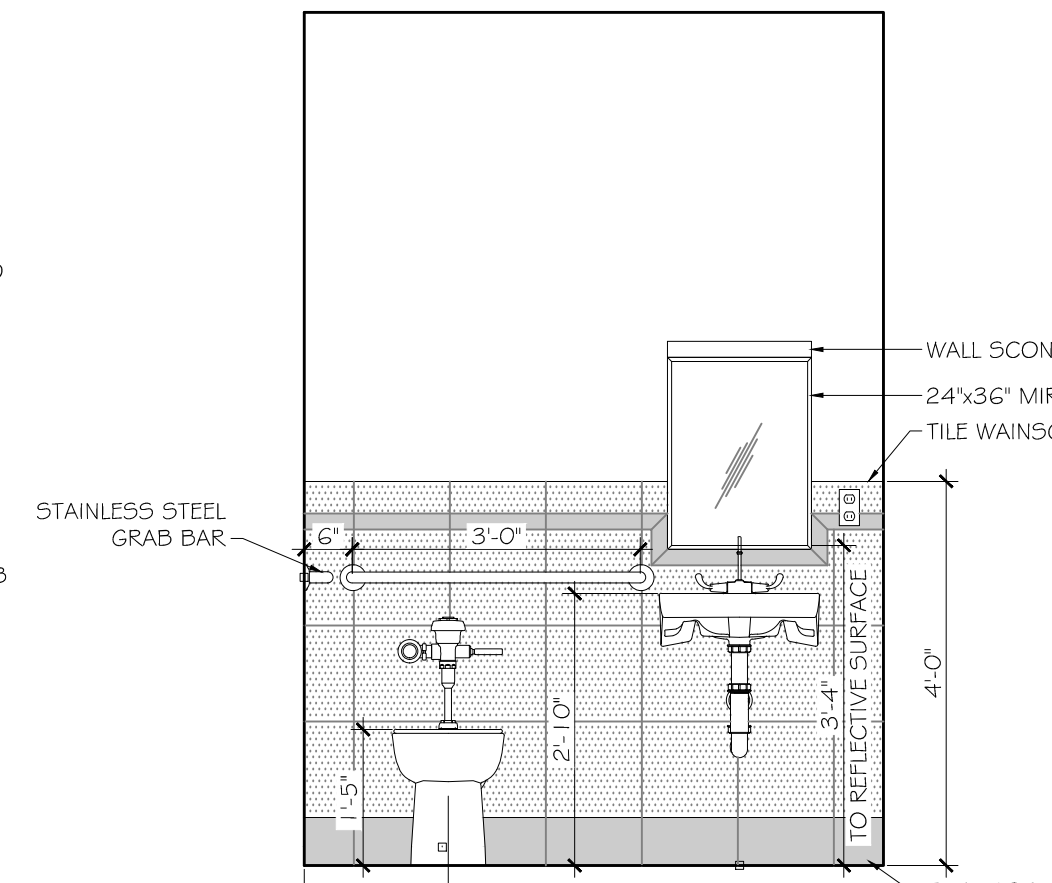

0 INTERIOR ELEVATION - WOMEN'S TOILET
SCALE: 1/2" = 1'-0"

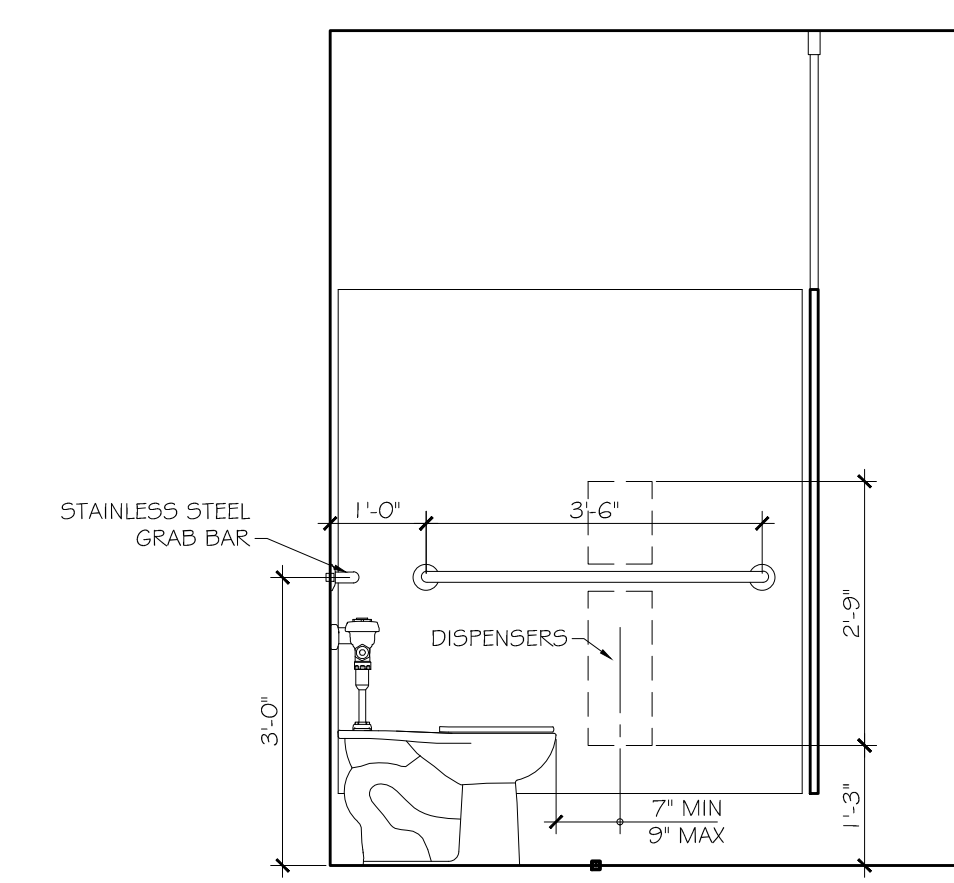

9 INTERIOR ELEVATION - MEN'S TOILET
SCALE: 1/2" = 1'-0"

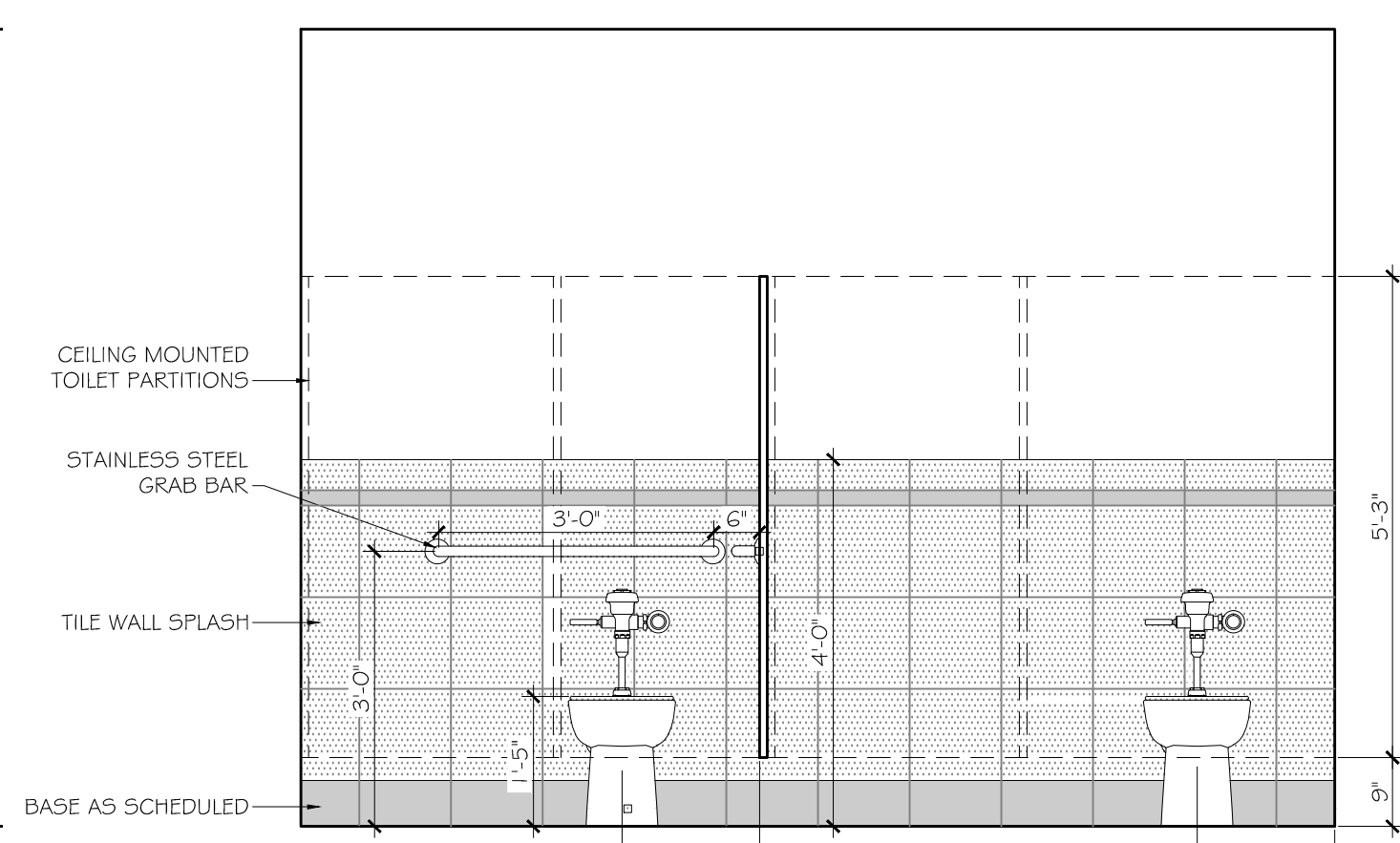

8 INTERIOR ELEVATION - MEN'S TOILET
SCALE: 1/2" = 1'-0"

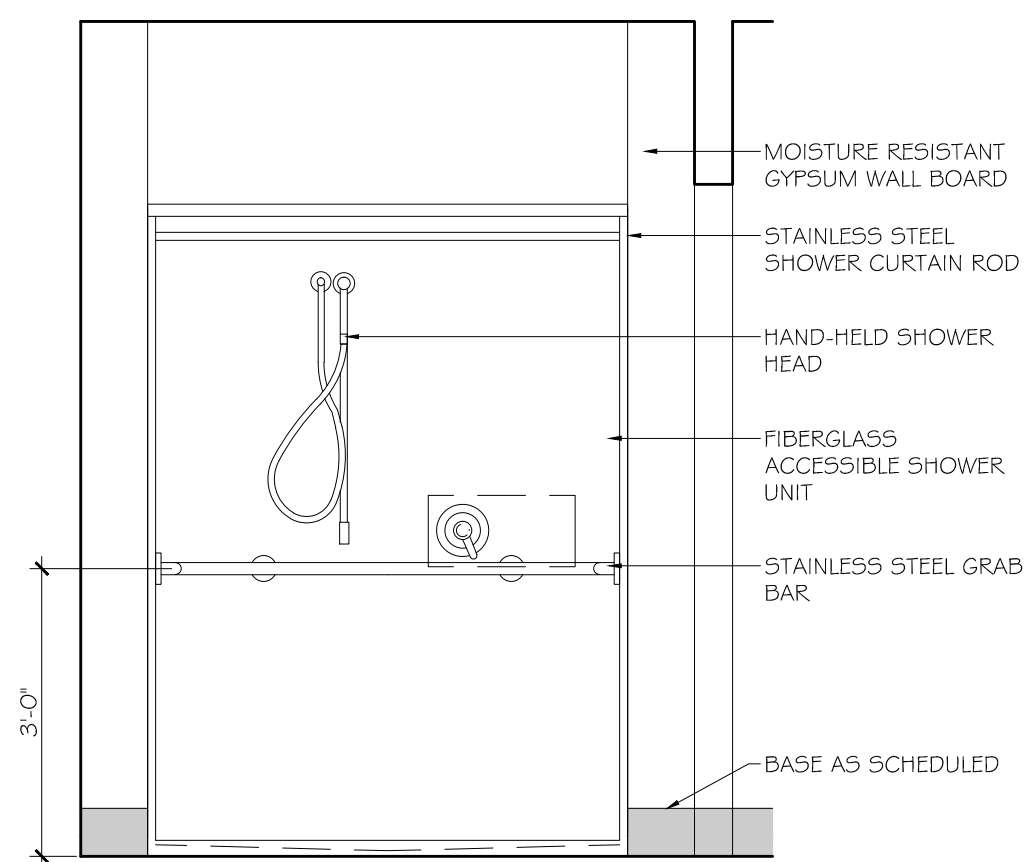

7 INTERIOR ELEVATION - MEN'S SHOWER
SCALE: 1/2" = 1'-0"

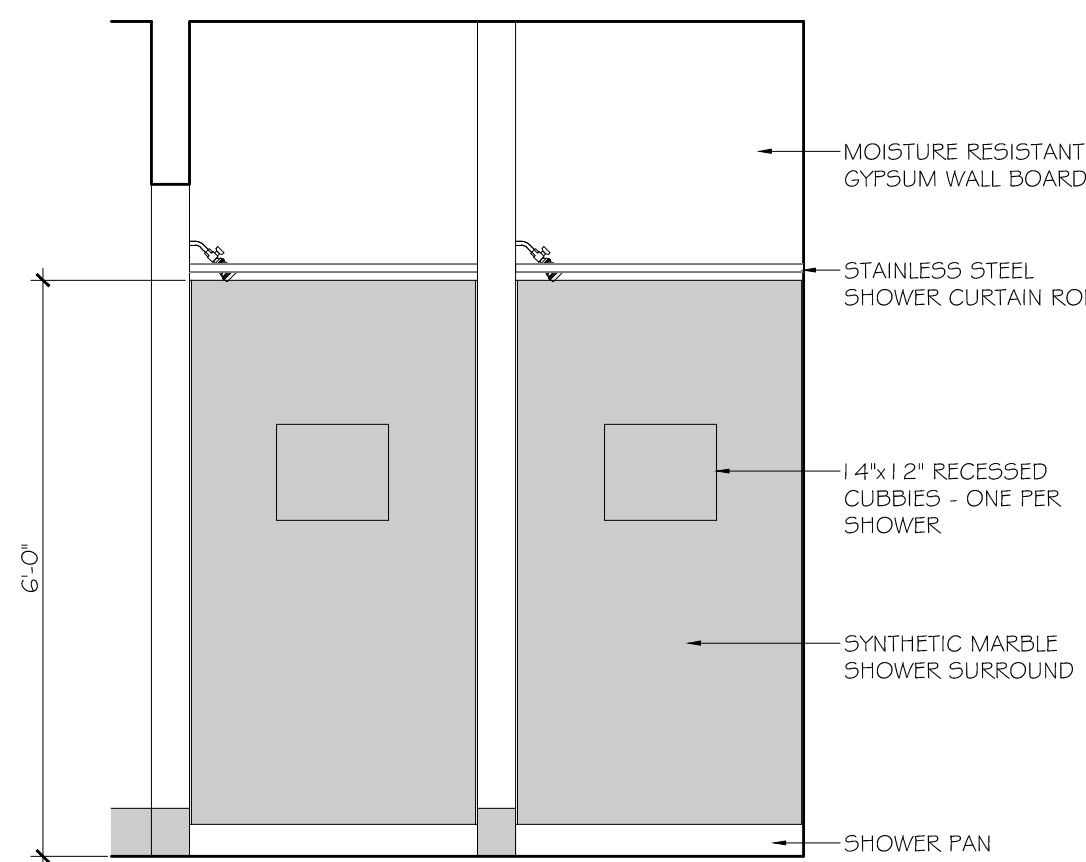

6 INTERIOR ELEVATION - MEN'S SHOWER
SCALE: 1/2" = 1'-0"

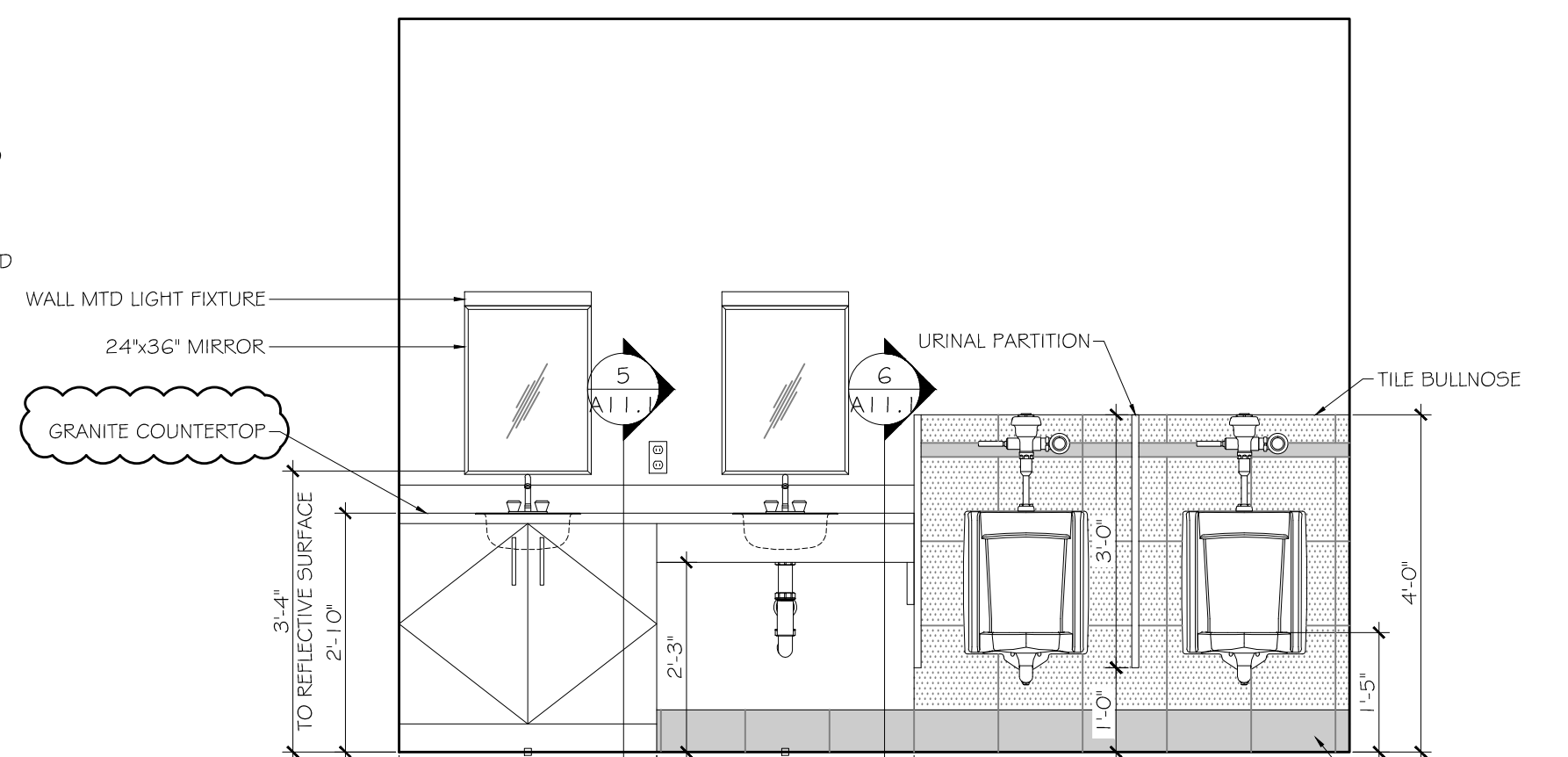

5 INTERIOR ELEVATION - MEN'S TOILET
SCALE: 1/2" = 1'-0"

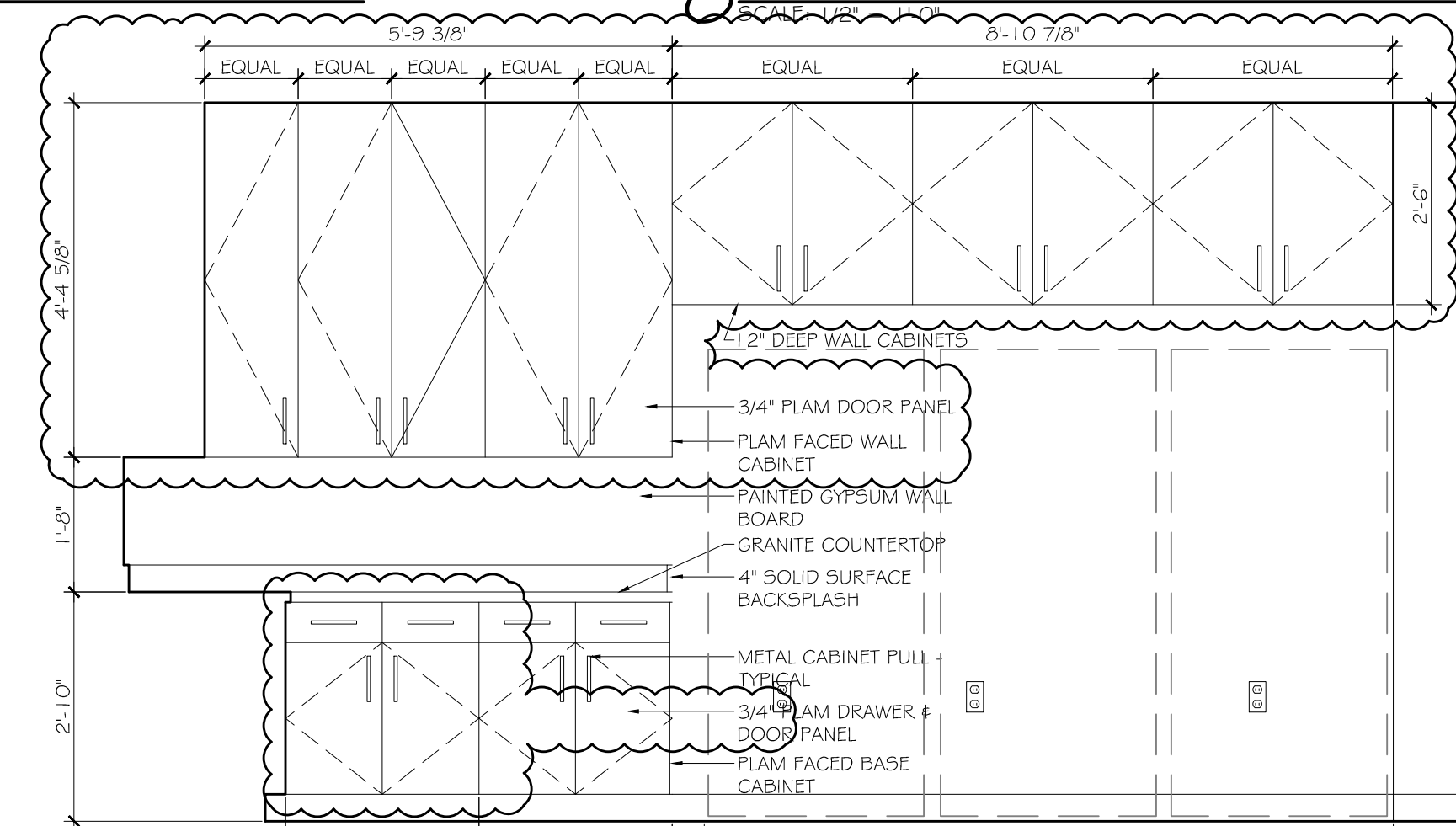

4 INTERIOR ELEVATION - KITCHEN
SCALE: 1/2" = 1'-0"

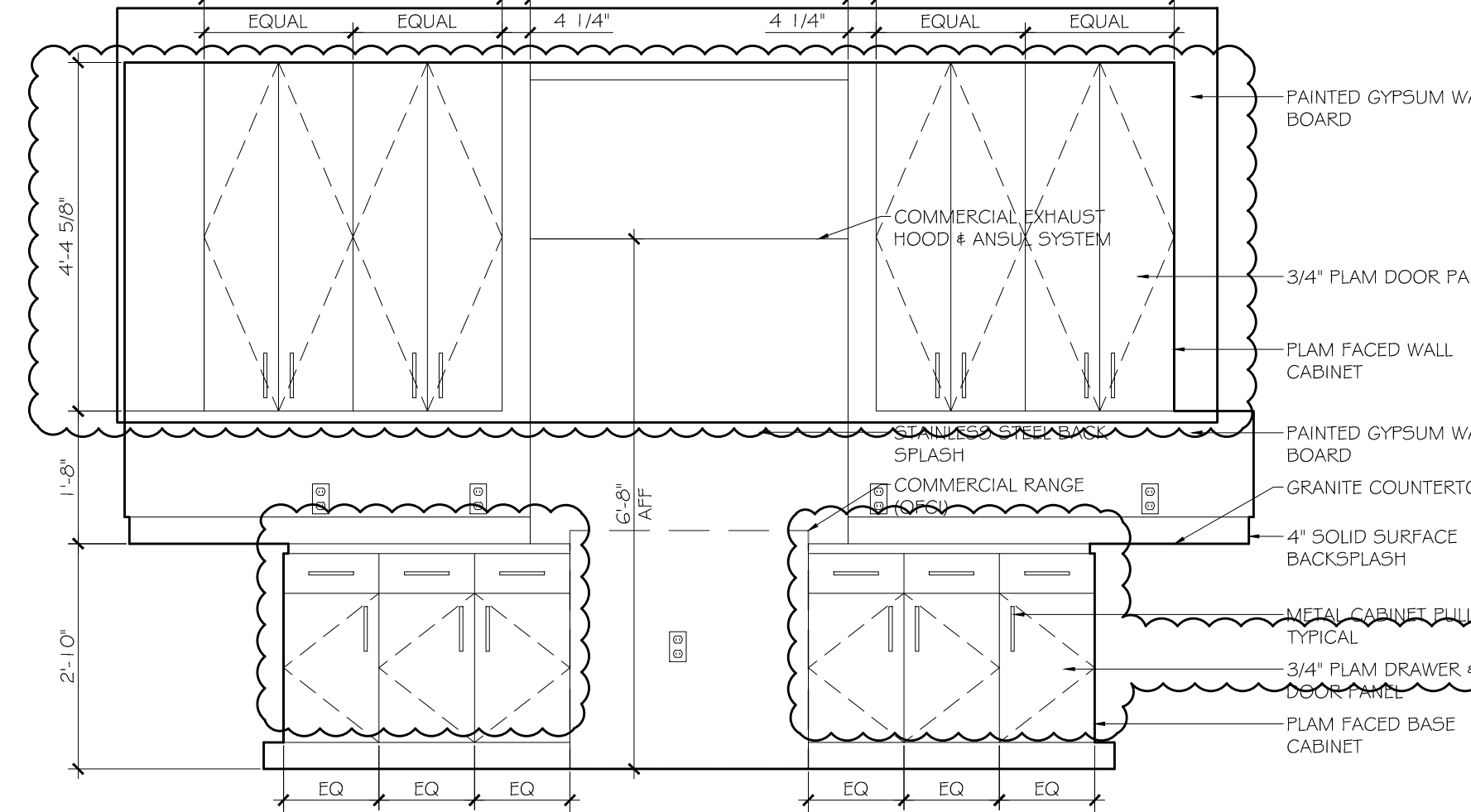

3 INTERIOR ELEVATION - KITCHEN
SCALE: 1/2" = 1'-0"

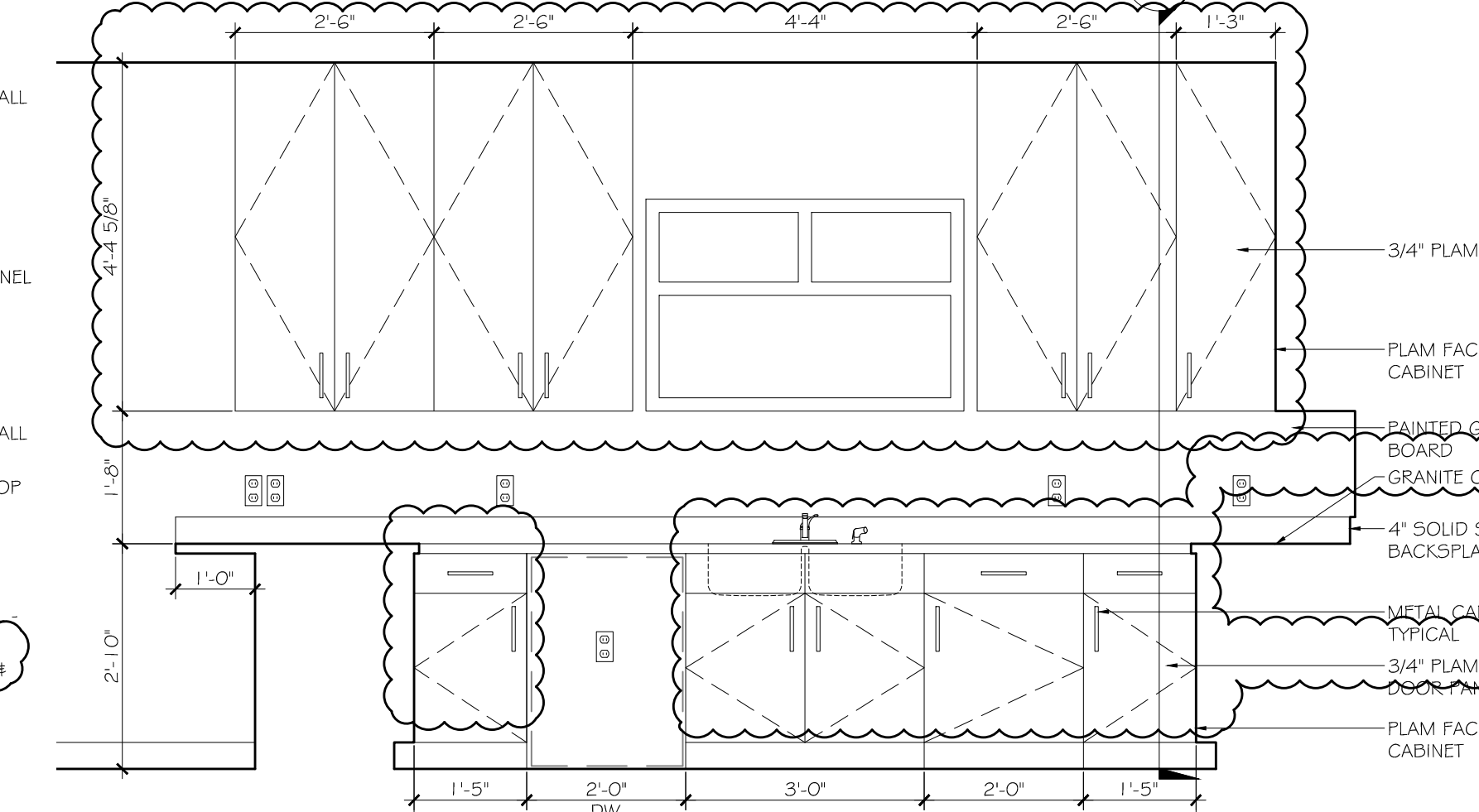

2 INTERIOR ELEVATION - KITCHEN
SCALE: 1/2" = 1'-0"

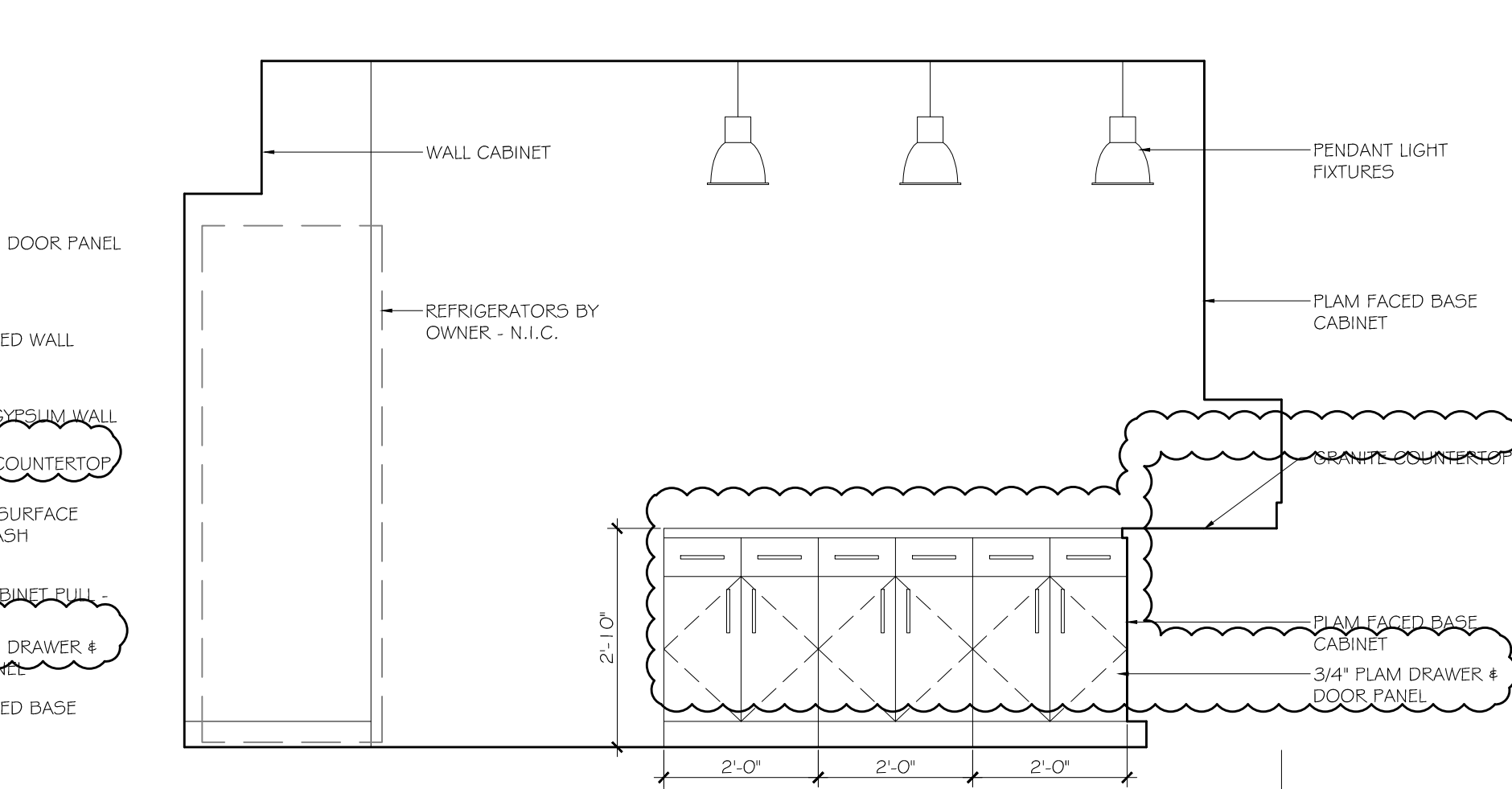

1 INTERIOR ELEVATION - KITCHEN
SCALE: 1/2" = 1'-0"

DAMMON ENGINEERS & ARCHITECTS
Architects & Engineers
554 OLD SPANISH TRAIL
SUDELL, LA 70458
PHONE: 985-649-5332
FAX: 985-641-9950

ST. TAMMANY FIRE PROTECTION DISTRICT No 1
FIRE STATION # 14
297 STEELE ROAD
SUDELL, LA

JOB No: 2161
DATE: 4/30/2013
DRAWN BY: KJK
CHECKED BY: KJK

REVISIONS
DESCRIPTION
1 CHANGE ORDER NO. 1

DATE
X-XX-2013

INTERIOR ELEVATIONS
SHEET No: 20 OF 32
All

9/25/13