

Aluminum Storefront - Kawneer IR501 Product Details

BROADMOOR, L.L.C.

I hereby agree that the (equipment) (material) (article) shown and marked in this submittal is that proposed to be incorporated with contract number N69450-05-D-0096, is in compliance with the contract documents, can be installed in the allocated spaces, and is submitted for Government approval.

Robert V. Allen 5.12.09

DQC Manager

Date

Andrew McCull

QC Officer

5/12/09

Date

Other: _____
 Deleted _____
 Saved and Resubmit _____
 Reviewed as Noted _____
 Reviewed: _____
 Date: _____

DYNAMIC ENGINEERING INC

DAMMON ENGINEERING INC

Date: 5.12.04 Project: Stennis ROP

Reviewed as Noted: _____

Revised and Resubmit: _____

Rejected: _____

Other: _____

Corrections or comments made on the shop drawings during this review do not relieve the contractor from compliance with requirements of the drawings and specifications. This check is only for review of the general conformance with the design concept of the project and general compliance with the information given in the contract documents. This contractor is responsible for confirming and correcting all quantities and dimensions; selecting fabrication processes and techniques of construction; coordinating his or her work with that of all other trades and performing all in a safe and satisfactory manner.

Submitted Item: Alum. Insulators
Comments _____

APPLICABLE TO FIXED ALUMINUM STOREFRONT WINDOWS AND
ENTRANCE FRAMING - RIVERINE

JANUARY, 2005

IR 500/501

1

EG-97903-01

FEATURES

HURRICANE RESISTANT PRODUCT

To be used at all typical window openings
with exception of Window "C" at Bldg 2440
which will require "1600 Wall" Framing

KAWNEER IR 501 SYSTEM

Features

- IR 500/501 is 5" deep and has a 2-1/2" sightline (Expansion mullions have a 2-3/4" sightline)
- Screw Spline fabrication
- Center glazed
- Outside glazed with internal silicone seal
- IR 500 glazing options are 9/16", 5/8" and 1/4" (non-impact)
- IR 501 glazing options are 1-5/16" and 1" (non-impact)
- Permanodic® anodized finishes in 7 choices
- Painted finishes in standard and custom choices

2 1/2" x 5" PROFILE DIM.

Optional Features

- Integrated entrance framing
- 350 IR Medium Stile - single or pairs of entrances
- IR 500 - shop or field glazed

Product Applications

- Impact resistant
- Storefront, ribbon window or punched opening
- Low to mid-rise
- Single span

For specific product applications,
Consult your Kawneer representative.

Laws and building and safety codes governing the design and use of glazed entrance, window, and curtain wall products vary widely. Kawneer does not control the selection of product configurations, operating hardware, or glazing materials, and assumes no responsibility therefor.

Kawneer reserves the right to change configuration without prior notice when deemed necessary for product improvement.

© Kawneer Company, Inc., 2008



SCALE 3" = 1'-0"

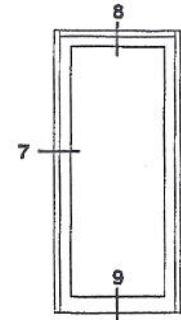
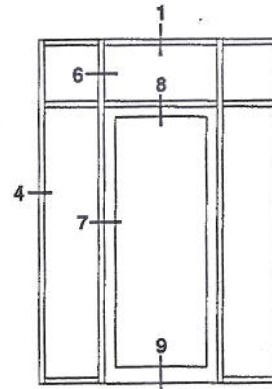
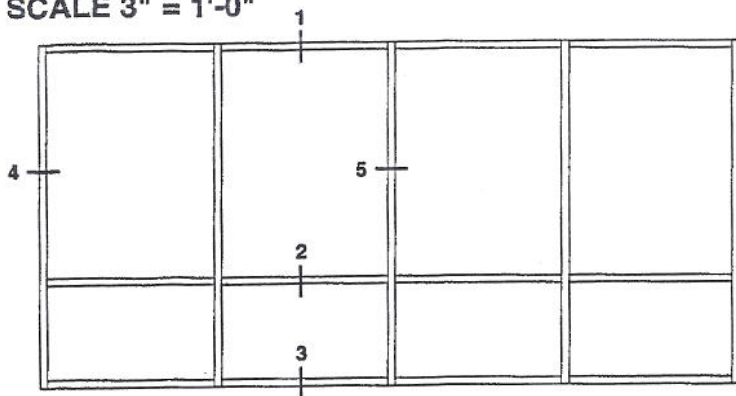

ELEVATIONS ARE NUMBER KEYED TO DETAILS

1-5/16" INFILL
APPLICABLE TO RIVERINE PROJECT

1" INFILL (NON-IMPACT)

CAD DETAIL = IR501_1-516_pg01.dwg

CAD DETAIL = IR501_1_pg01.dwg

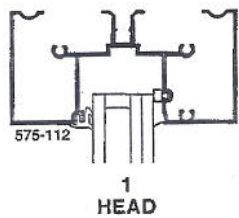
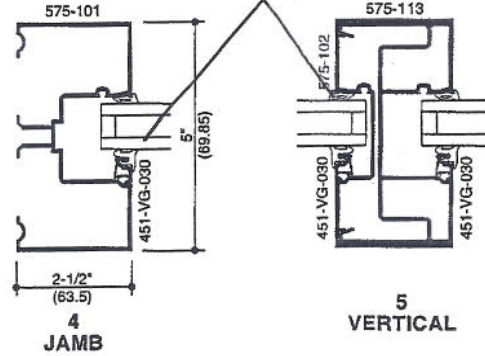
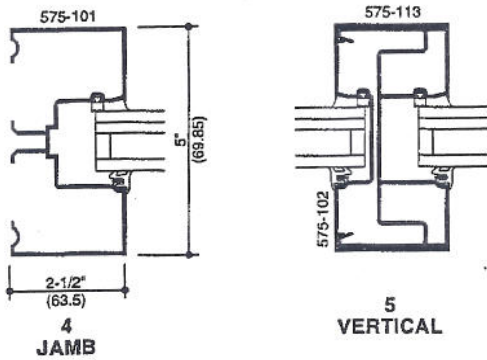

1 HEAD

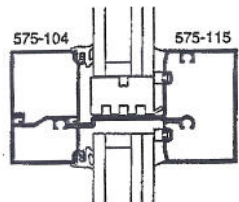

2 HORIZONTAL

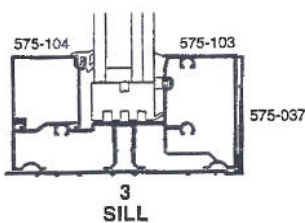

3 SILL

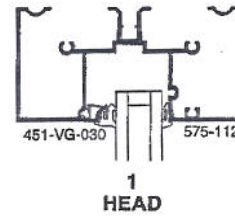

1 HEAD

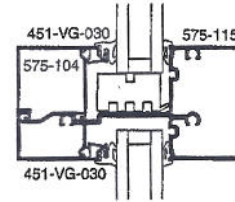

2 HORIZONTAL

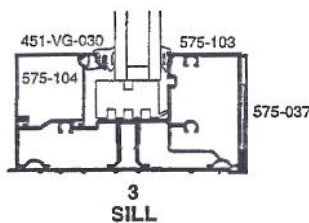

3 SILL

Laws and building and safety codes governing the design and use of glazed entrance, window, and curtain wall products vary widely. Kawneer does not control the selection of product configurations, operating hardware, or glazing materials, and assumes no responsibility therefor.

Kawneer reserves the right to change configuration without prior notice when deemed necessary for product improvement.
© Kawneer Company, Inc., 2006

SCALE 3" = 1'-0"

1-5/16" INFILL

CAD DETAIL = IR501_1-516_pg02.dwg

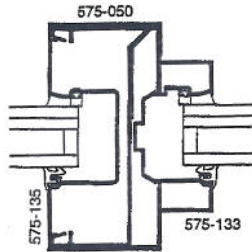

6
DOOR JAMB AT TRANSOM

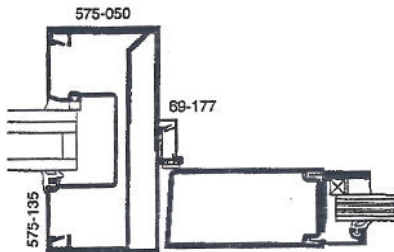

7
DOOR JAMB

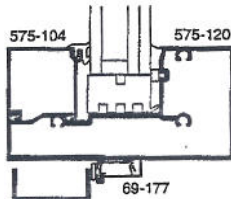

8
DOOR WITH
TRANSOM



9
BOTTOM RAIL

1" INFILL (NON-IMPACT)

CAD DETAIL = IR501_1_pg02.dwg

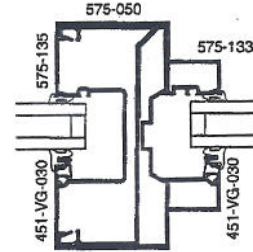

6
DOOR JAMB AT TRANSOM

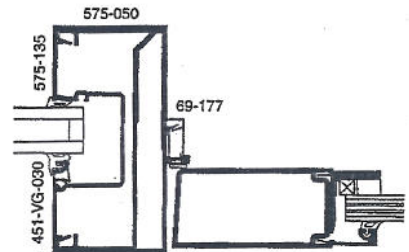

7
DOOR JAMB

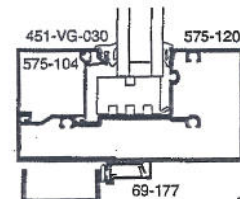

8
DOOR WITH
TRANSOM

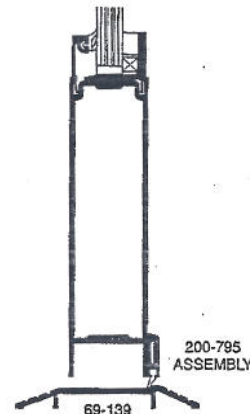

9
BOTTOM RAIL

Laws and building and safety codes governing the design and use of glazed entrance, window, and curtain wall products vary widely. Kawneer does not control the selection of product configurations, operating hardware, or glazing materials, and assumes no responsibility therefor.

Kawneer reserves the right to change configuration without prior notice when deemed necessary for product improvement.
© Kawneer Company, Inc., 2006



SCALE 3" = 1'-0"

CADDDETAIL (1-5/16) = IR501_1-516_pg03.dwg
CAD DETAIL (1") = IR501_1_pg03.dwg

Laws and building and safety codes governing the design and use of glazed entrance, window, and curtain wall products vary widely. Kawneer does not control the selection of product configurations, operating hardware, or glazing materials, and assumes no responsibility therefor.

Kawneer reserves the right to change configuration without prior notice when deemed necessary for product improvement.
© Kawneer Company, Inc., 2005

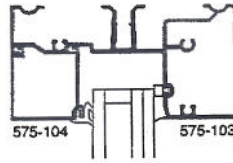

OPTIONAL HEAD WITH STOP

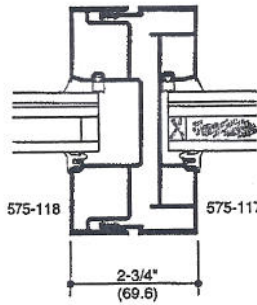

EXPANSION MULLION

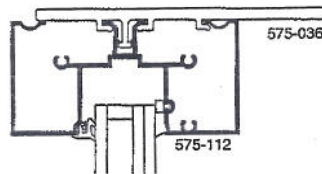
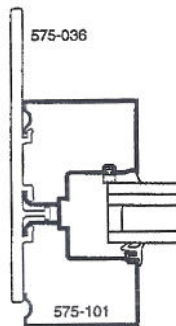

STRAP ANCHORS



Aluminum Storefront - Kawneer 1600 Wall Product Details (Window C - Bldg 2440)

BROADMOOR, L.L.C.

I hereby agree that the (equipment) (material) (article) shown and marked in this submittal is that proposed to be incorporated with contract number N69450-05-D-0096, is in compliance with the contract documents, can be installed in the allocated spaces, and is submitted for Government approval.

Robert Adams 5.12.09

DQC Manager

Date

Jeffrey M. Geller 5/12/09

QC Officer

Date

DAMMON ENGINEERING INC

Date: 5.12.09 Project: Stennis ROF
 Reviewed: X
 Reviewed as Noted: _____
 Revise and Resubmit: _____
 Rejected: _____
 Other: _____

Corrections or comments made on the shop drawings during this review do not relieve the contractor from compliance with requirements of the drawings and specifications. This check is only for review of the general conformance with the design concept of the project and general compliance with the information given in the contract documents. This contractor is responsible for confirming and correlating all quantities and dimensions; selecting fabrication processes and techniques of construction; coordinating his or her work with that of all other trades and performing all in a safe and satisfactory manner.

Submittal Item: Kawneer Window "C" Comments

KAWNEER 1600 WALL SYSTEM

Features

- 1600 Wall System®1 is an outside glazed captured curtain wall
- 1600 Wall System®1 has a 2-1/2" (63.5) sight line
- Standard ~~8~~" (152.4) or 7~~1/2~~" (190.5) depth systems
- Infill options up to 1-1/8" (28.6)
- Concealed fastener joinery creates smooth, monolithic appearance
- Open-back horizontals and perimeters are available for cost savings
- Shear block fabrication method
- Corners and splayed mullions available
- Offers integrated entrance framing systems
- Silicone compatible glazing materials for long-lasting seals
- 1600 Wall System®1 has been small and large missile impact and cycle tested
- Two color option
- Permanodic® anodized finishes in 7 choices
- Painted finishes in standard and custom choices

PROFILE DIMENSIONS
 2 1/2" x 7 13/16" @ RIVERINE PROJECT

Optional Features

- Steel reinforcing available
- Rain screen and backpans
- Optional deep profile and bull nose covers available
- Deep and heavy-weight mullions available
- Veneer system available
- Integrates with standard Kawneer windows and concealed GLASSvent™
- Integrates with 1600 SUNSHADE™ and 1600 POWERSHADE®

Product Applications

- Ideal for low to mid-rise applications where high performance is desired
- It also is the right choice for high span applications

For specific product applications,
 Consult your Kawneer representative.

Laws and building and safety codes governing the design and use of glazed entrance, window, and curtain wall products vary widely. Kawneer does not control the selection of product configurations, operating hardware, or glazing materials, and assumes no responsibility therefor.

Kawneer reserves the right to change configuration without prior notice when deemed necessary for product improvement.
 © Kawneer Company, Inc., 2009

Laws and building and safety codes governing the design and use of glazed entrance, window, and curtain wall products vary widely. Kawneer does not control the selection of product configurations, operating hardware, or glazing materials, and assumes no responsibility therefor.

Kawneer reserves the right to change configuration without prior notice when deemed necessary for product improvement.

© Kawneer Company, Inc., 2009

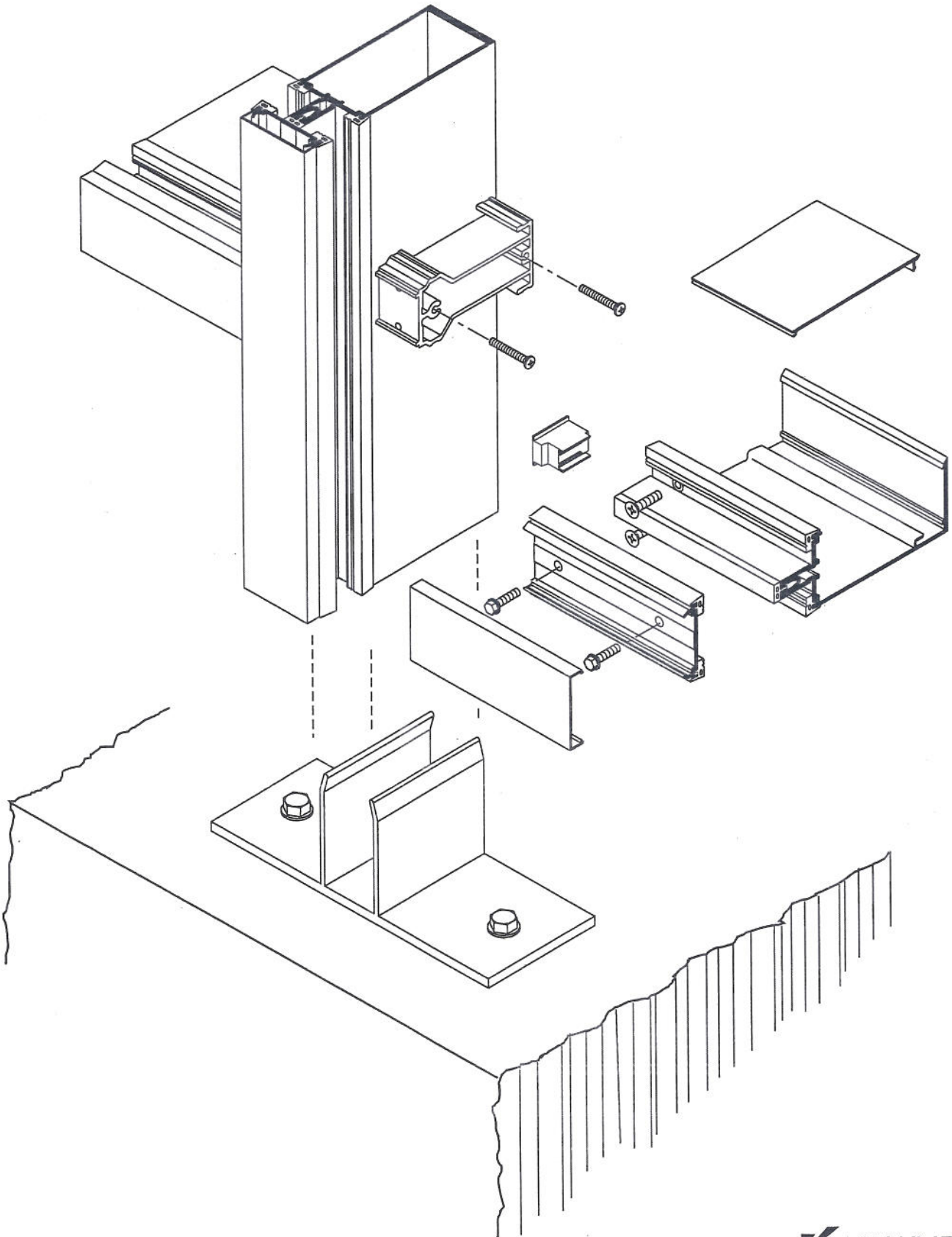

RIVERINE PROJECT WILL UTILIZE
 1 5/16" INSULATED-LAMINATED GLASS
 INFILL IN LIEU OF 1" SHOWN

SCALE 3" = 1'-0"

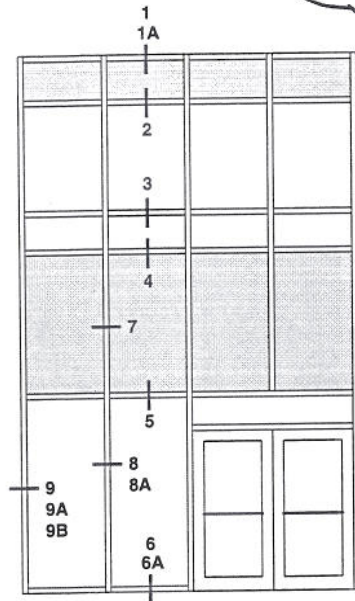

ELEVATION IS NUMBER KEYED TO DETAILS

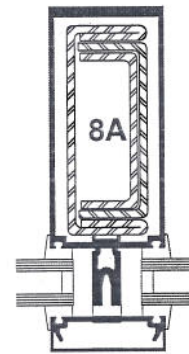
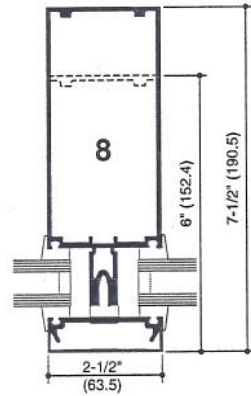
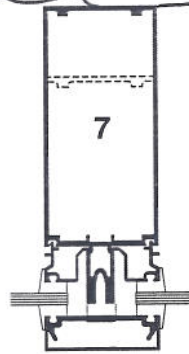

OPTIONAL STEEL REINFORCING AS REQUIRED

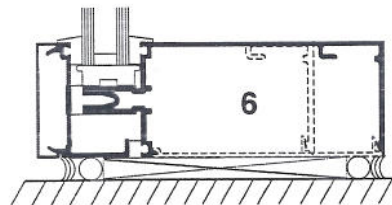
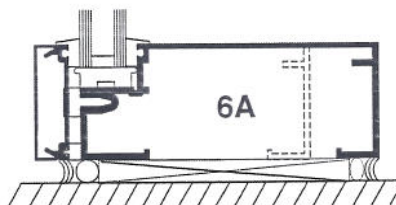
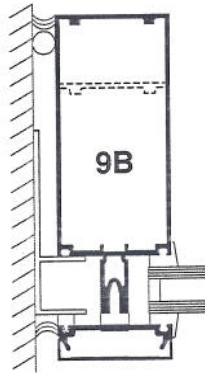
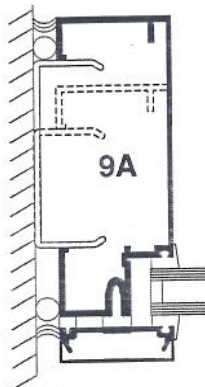
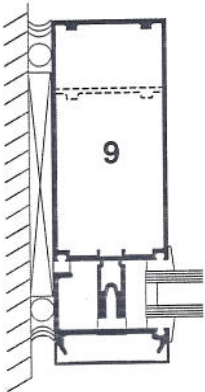
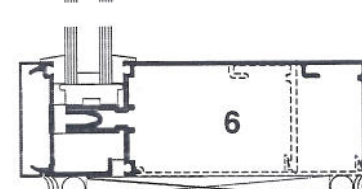
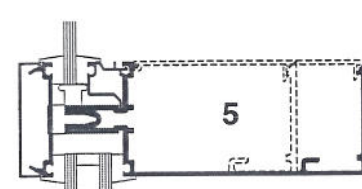
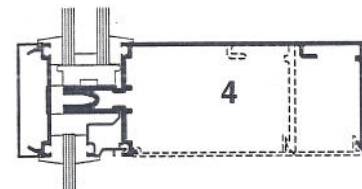
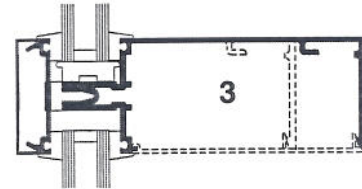
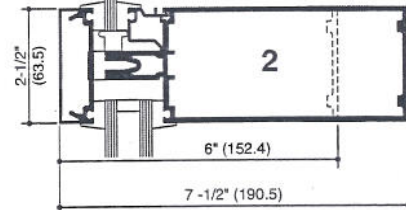
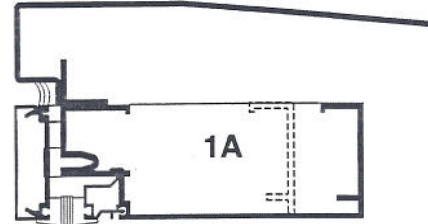
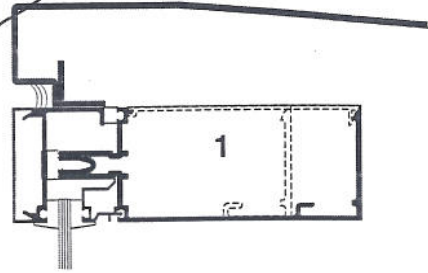

Laws and building and safety codes governing the design and use of glazed entrance, window, and curtain wall products vary widely. Kawneer does not control the selection of product configurations, operating hardware, or glazing materials, and assumes no responsibility therefor.

Kawneer reserves the right to change configuration without prior notice when deemed necessary for product improvement.
 © Kawneer Company, Inc., 2009

SCALE 3" = 1'-0"

NOTE: 1" SYSTEM SHOWN, 1/4" SYSTEM SIMILAR.

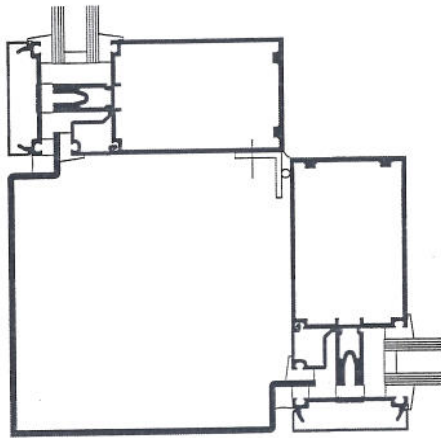

90° OUTSIDE CORNER

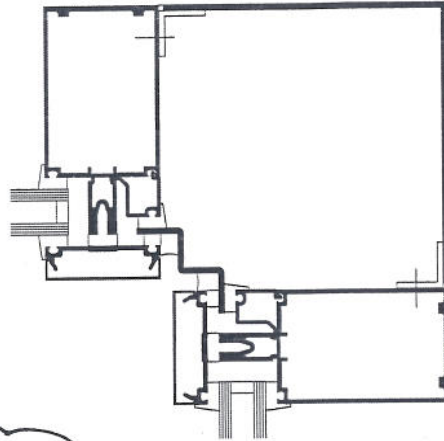

90° INSIDE CORNER

RIVERINE PROJECT LEAN-OUT WINDOW TYPE "C"
ON BLDG 2440 WILL USE SIMILAR CORNER
DETAIL

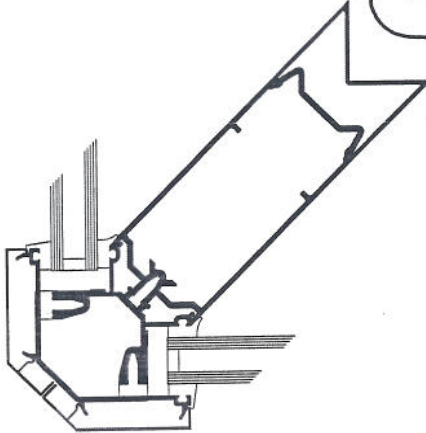

90° OUTSIDE CORNER

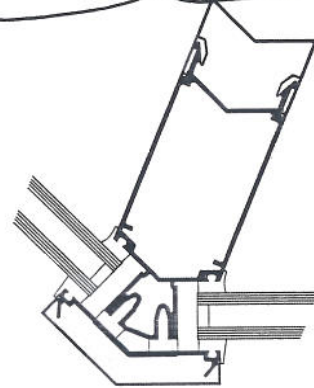

135° OUTSIDE CORNER

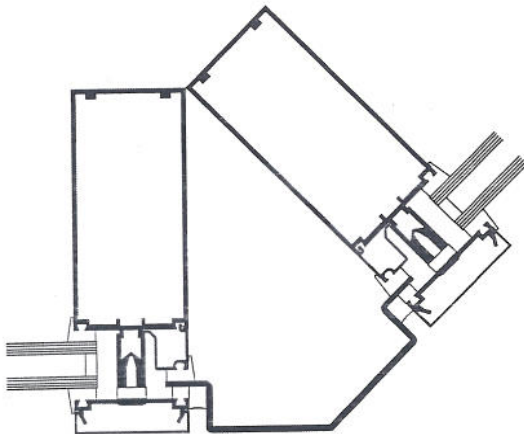

135° OUTSIDE CORNER

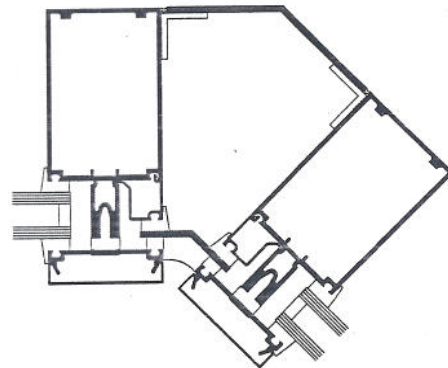

135° INSIDE CORNER

Laws and building and safety codes governing the design and use of glazed entrance, window, and curtain wall products vary widely. Kawneer does not control the selection of product configurations, operating hardware, or glazing materials, and assumes no responsibility therefor.

Kawneer reserves the right to change configuration without prior notice when deemed necessary for product improvement.

© Kawneer Company, Inc., 2009

SCALE 3" = 1'-0"

NOTE: 350 IR DOORS ARE USED WITH IMPACT FRAMING. DOORS ARE GLAZED WITH 9/16" INFILL.

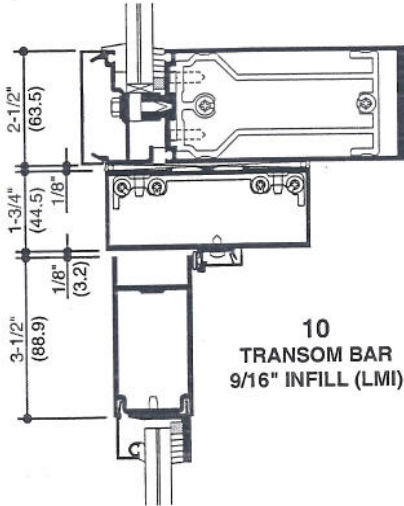
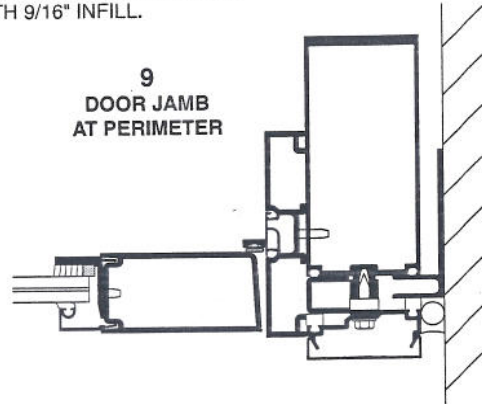
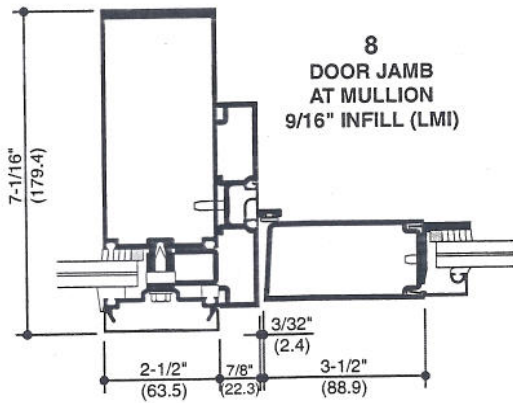

OPTIONAL 10" DEEP SYSTEM 9/16" INFILL (LMI)

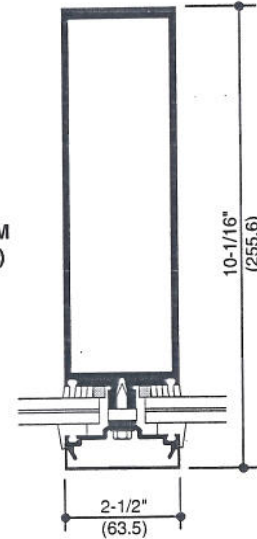

GLAZING OPTIONS

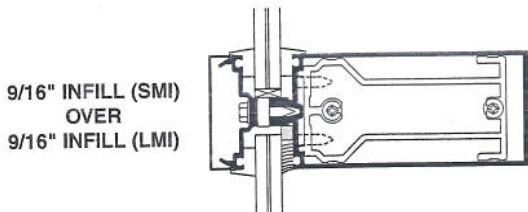
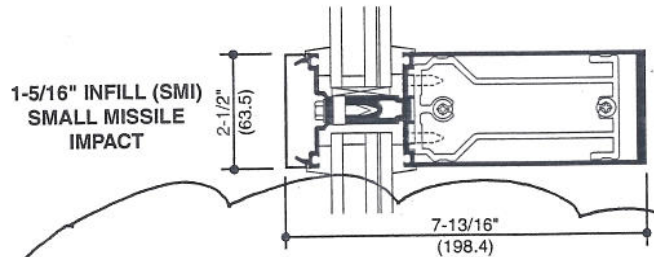
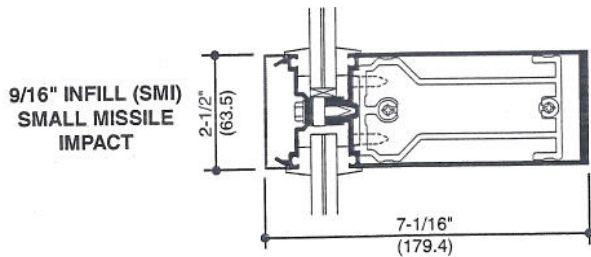

1-5/16" INFILL (LMI) *LARGE MISSILE IMPACT

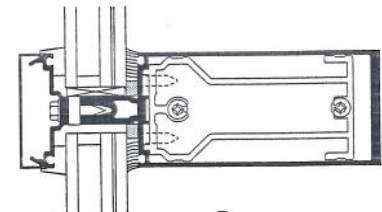

APPLICABLE TO RIVERINE PROJECT

Insulated-Laminated Glass Infill

Laws and building and safety codes governing the design and use of glazed entrance, window, and curtain wall products vary widely. Kawneer does not control the selection of product configurations, operating hardware, or glazing materials, and assumes no responsibility therefor.

Kawneer reserves the right to change configuration without prior notice when deemed necessary for product improvement. © Kawneer Company, Inc., 2009

Kawneer 1600 Wall UFC Performance Test Report

BROADMOOR, L.L.C.

I hereby agree that the (equipment) (material) (article) shown and marked in this submittal is that proposed to be incorporated with contract number N69450-05-D-0096, is in compliance with the contract documents, can be installed in the allocated spaces, and is submitted for Government approval.

Robert White 5.12.09
DQC Manager Date

George M. Carter 5/12/09
QC Officer Date

DAMMON ENGINEERING INC

Date: 5.12.09 Project: Stennis ROF
Reviewed: _____
Reviewed as Noted: _____
Revise and Resubmit: _____
Rejected: _____
Other: _____

Corrections or comments made on the shop drawings during this review do not relieve the contractor from compliance with requirements of the drawings and specifications. This check is only for review of the general conformance with the design concept of the project and general compliance with the information given in the contract documents. This contractor is responsible for: confirming and correlating all quantities and dimensions; selecting fabrication processes and techniques of construction; coordinating his or her work with that of all other trades and performing all in a safe and satisfactory manner.

Submittal Item: Kawneer Test Report Comments

BLAST TEST REPORT (UFC)

1225
95438-63

APPLICABLE TO WINDOW "C" BLDG 2440 - RIVERINE

Kawneer Company, Inc. - Blast Resistant Windows Test Report T049-0112-06



Hurricane Test Laboratory, LLC
Testing and Evaluation Solutions
3417 73rd Street, Suite D
Lubbock, Texas 79423
www.htltest.com

Full Scale Arena Blast Test per ASTM F 1642-04 Kawneer Company, Inc., Norcross, Georgia

Test Site:

Hurricane Test Laboratory, LLC, Field Site
Lynn County, Texas
February 1, 2006

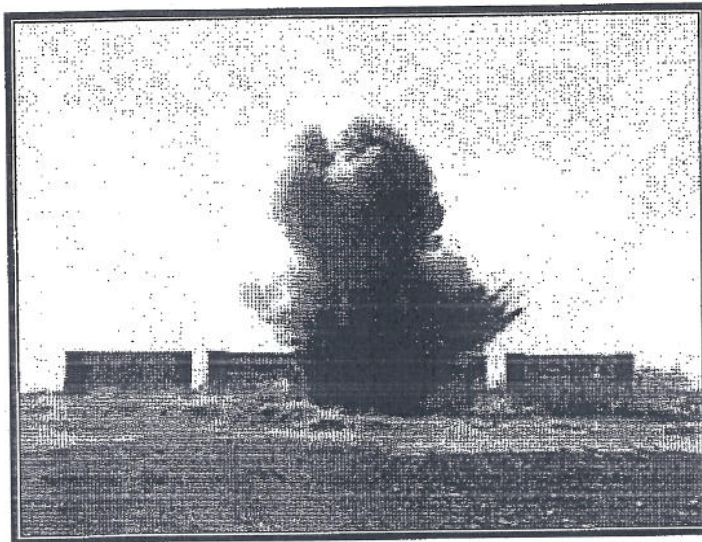

Test Summary:

Hurricane Test Laboratories, LLC, conducted a single full scale arena blast test with three (3) identical test specimens of the 350HW Door with 1600 System 1 Framing with Project-Out Glassvent and three (3) identical test specimens of the 8325TL Fixed over Project-Out Window for Kawneer Company, Inc. The test specimens were manufactured, fabricated and installed per Kawneer Company's drawings TUD162-100B (Sheets 1-16). Each test specimen underwent the specified test pressure 6 psi peak air blast pressure and 42 psi-ms positive phase impulse.



*Testing & Evaluation
Solutions*

www.htltest.com

March 08, 2006

Attn: Mr. Donnie Hunter
Kawneer Company
555 Guthridge Ct.
Technology Park/Atlanta
Norcross, Georgia 30092

Subject: Full Scale Area Blast Test on Feb 1, 2006

Dear Mr. Donnie Hunter:

I have attached the independent test report for the full scale arena blast test we performed on the "350HW Door with 1600 System 1 Framing with Project-Out Glassvent" storefront and the "8325TL Fixed over Project-Out Windows." We performed this test per the specifications set forth by ASTM F1642-04.

Hurricane Test Laboratory performed this test using 300 pounds of ANFO with a standoff distance of 125 feet. This charge produced a peak air blast pressure and positive phase impulse above the required pressure of 6 psi and 42 psi-msec respectively.

Please feel free to contact me if you have any questions or require further assistance.

Sincerely,

Steven R. Samuels
Operations Manager
Hurricane Test Laboratory, LLC

Hurricane Test Laboratory, LLC
3417 73rd Street, Suite D
Lubbock, Texas 79423
806-797-2208

Kawneer Company, Inc. - Blast Resistant Windows
Test Report T049-0112-06



Hurricane Test Laboratory, LLC
Testing and Evaluation Solutions
3417 73rd Street, Suite D
Lubbock, Texas 79423
www.htltest.com

Full Scale Arena Blast Test per ASTM F 1642-04
Kawneer Company, Inc., Norcross, Georgia

Test Site:
Hurricane Test Laboratory, LLC, Field Site
Lynn County, Texas
February 1, 2006

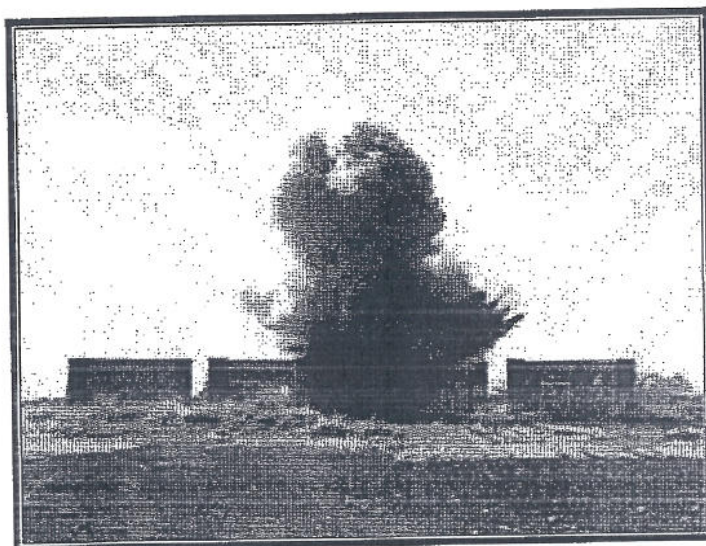

Test Summary:

Hurricane Test Laboratories, LLC, conducted a single full scale arena blast test with three (3) identical test specimens of the 350HW Door with 1600 System 1 Framing with Project-Out Glassvent and three (3) identical test specimens of the 8325TL Fixed over Project-Out Window for Kawneer Company, Inc. The test specimens were manufactured, fabricated and installed per Kawneer Company's drawings TUD162-100B (Sheets 1-16). Each test specimen underwent the specified test pressure 6 psi peak air blast pressure and 42 psi-ms positive phase impulse.

PREFACE

Hurricane Test Laboratory, LLC (HTL) conducted a single full scale arena blast test for Kawneer Company, Inc. in Norcross, Georgia on February 01, 2006, at the HTL remote blast site located in Lynn County, Texas. HTL evaluated three (3) identical "350HW Door with 1600 System 1 Framing with Project-Out Glassvent" and three (3) identical "8325TL Fixed over Project-Out Windows" to evaluate the hazard rating per ASTM F 1642-04: Glazing and Glazing Systems Subject to Airblast Loadings (ASTM F1642-04). This report documents the test results for the specified windows.

HTL provided the blast reaction chambers, test planning, data acquisition system, test execution, and report documentation. Mr. Steven R. Samuels acted as the test director for HTL and Mr. Vinu Abraham, also from HTL, witnessed the test. Kawneer Company designed, manufactured, and installed their test specimen at an offsite location and shipped the preassembled windows to HTL's test site. Mr. Donnie Hunter served as the product manager and as a witness for Kawneer Company.

ABSTRACT

Kawneer Company in Norcross, Georgia commissioned HTL to perform a single full scale arena blast test with three (3) identical storefront systems and three (3) identical window specimens in accordance with ASTM F 1642-04. Kawneer Company designed, manufactured, and preassembled their single span test specimens offsite per Kawneer Company's drawings TUD162-100B (Sheets 1-16), provided in Appendix A, and shipped the completed systems to our remote test facility in Lynn County, Texas. HTL installed their preassembled window buck into the HTL blast reaction chambers. HTL instrumented the blast reaction chambers with pressure transducers to record the reflected air blast pressure acting on the windows and a free field pressure transducer to measure the incident air blast pressure. The test charge size consisted of 300 lbs (136 kg) of Ammonium Nitrate Fuel Oil (ANFO) at a standoff distance of 124 ft (37.8 m). This created a peak overpressures within ten (10) percent of 6 psi (41.37 kPa) and a positive phase impulse of 42 psi-ms (289.7 kPa-ms) acting on the reflecting surface.

Two (2) of Kawneer Company's "350HW Door with 1600 System 1 Framing with Project-Out Glassvent" provided protection consistent with a "*Low Hazard*" in accordance with ASTM F 1642-04. Some glass fragments flew into the opening with a sum total united dimension of greater than 10 in. (25 cm) for each specimen. One (1) of Kawneer Company's "350HW Door with 1600 System 1 Framing with Project-Out Glassvent" provided protection consistent with a "*High Hazard*" in accordance with ASTM F 1642-04. It should be noted Kawneer Company mistakenly installed one of the glass lites inside-out. If this was prevented, HTL strongly feels the third wall system would have also provided protection consistent with a "*Low Hazard*" rating per ASTM F1642-04. In all three (3) storefront systems the glazing fractured with no tears in the glazing interlayer and HTL observed zero length of pull out from the glass pocket.

Kawneer Company also tested their "8325TL Fixed over Project-Out Window." This window provided protection consistent with a "*Minimal Hazard*" per ASTM F1642-04. The glazing fractured with no tears in the glazing interlayer and HTL observed zero length pullout from the glass pocket. There were zero perforations caused by glazing slivers and zero fragment indents anywhere in the vertical witness panel.

BACKGROUND

Accidental and intentional explosions have heightened the need for blast resistance glazing. Glass shards historically cause many injuries as a result of air blast pressure loadings. Eliminating or reducing flying or falling glass shards greatly reduces or eliminates glass related injuries during an airblast pressure event.

American Standard for Testing and Materials (ASTM F 1642-04)

ASTM published a standard test method titled "F 1642-04: Glazing and Glazing Systems Subject to Airblast Loadings" (ASTM F 1642-04) that provides a protocol for conducting and assessing blast tests on glazing. This test method provides a means to evaluate the hazards of glazing or glazing systems subject to airblast loadings. Table 1 provides a summary of the different hazard ratings specified in ASTM F 1642-04, and Figure 1 provides a graphical presentation of the hazard ratings.

Table 1: Summary of the ASTM F1642-04: Glazing and Glazing Systems Subject to Airblast Loadings Hazard Rating for Glazings under Full Scale Blast Loading.

Hazard Rating	Description	Fragments	
		1 m to 3m	Witness Panel
No Break	The glazing is allowed to break and there is no visible damage to the framing system.	None	None
No Hazard	The glazing fractures but is fully retained in the facility test frame or glazing system frame and the rear surface is unbroken	None	None
Minimal Hazard	Glazing fractures and the total length of tears in the glazing plus the total length of pullout from the edge of the frame is less than 20% of the glazing sight perimeter.	< 10" unified dimension	3 or less perforations from glazing slivers and no fragment indents.
Very Low Hazard	Glazing fractures and is located within 1 meter of the original location	< 10" unified dimension	3 or less perforations from glazing slivers and no fragment indents.
Low Hazard	Glazing Fractures	Glazing fragments generally fall between 1 meter and 3 meters.	<10 perforations 50 cm below the bottom of the specimen and none of the perforations penetrate through the full thickness of the witness panel
High Hazard	Glazing Fractures	1 meter and 3 meters.	> 10 perforations in the area of the witness panel and one or more fragments penetrate fully through the witness panel

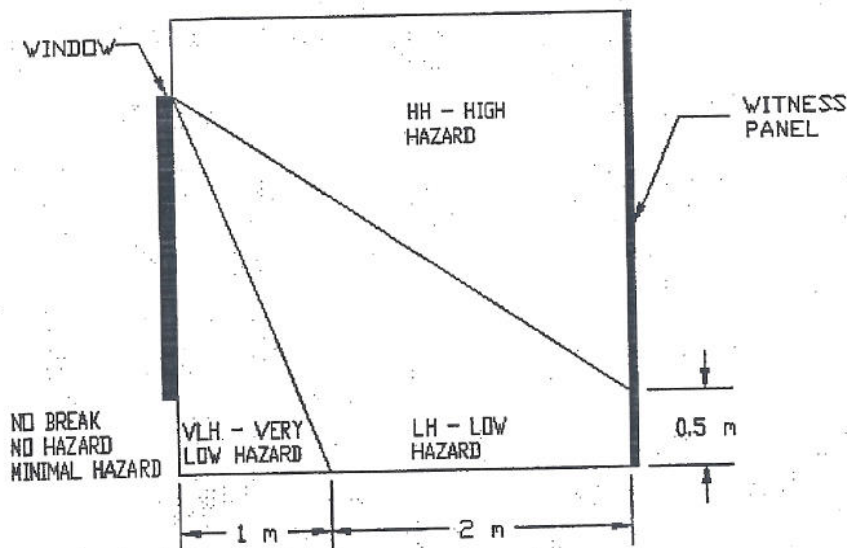

Figure 1: Cross-Section through Witness Area per ASTM F1642-04: Glazing and Glazing Systems Subject to Airblast Loadings.

US General Service Administration (GSA)

US General Service Administration published a standard titled "US General Service Administration Standard Test Method for Glazing and Window Systems Subject to Dynamic Overpressure Loading" (GSA) that provides a protocol for conducting and assessing blast tests on glazing. This test method provides a means to evaluate the hazards of glazing or glazing systems subject to airblast loadings. Table 2 provides a summary of the different hazard ratings specified in GSA and Figure 2 provides a graphical presentation of the hazard ratings.

Table 2: GSA Performance Condition for Window System Response

Performance Condition	Protection Level	Hazard Level	Description of Window Glazing Response
1	Safe	None	Glazing does not break. No visible damage to glazing or frame.
2	Very High	None	Glazing cracks but is retained by the frame. Dusting or very small fragments near sill or on the floor acceptable.
3a	High	Very Low	Glazing cracks. Fragments enter space and land on floor no further than 3.3 ft from the window.
3b	Medium	Medium	Glazing cracks. Fragments enter space and land on floor no further than 10 ft from the window.
4	Low	High	Glazing cracks. Fragments enter space and land on floor and impact a vertical witness panel at a distance of no more than 10 ft. from the window at a height no greater than 2 ft. above the floor.
5	Low	High	Glazing cracks and window system fails catastrophically. Fragments enter space impacting a vertical witness panel at a distance of no more than 10 ft. from the window at a height greater than 2 ft above the floor

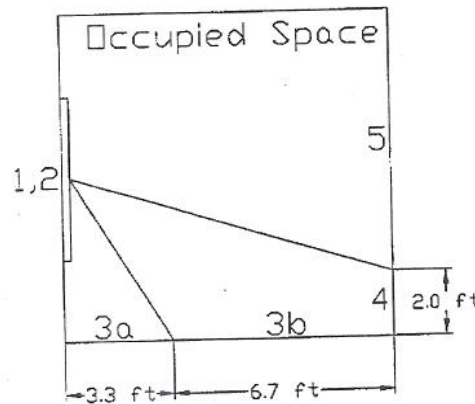

Figure 2: Cross-Section through Occupied Space per US General Service Administration Standard Test Method for Glazing and Window Systems Subject to Dynamic Overpressure Loading

Unified Facilities Criteria (UFC)

The Unified Facilities Criteria (UFC): *DoD Minimum Antiterrorism Standards for Building* published a document to “minimize the likelihood of mass casualties from terrorist attacks.” This document describes levels of protection for building occupants. These protection levels are described in Table 3.

Table 3: Levels of Protection per UFC 4-010-01 – New and Existing Buildings

Level of Protection	Potential Structural Damage	Potential Door and Glazing Hazard	Potential Injury
Below AT standards	Severely damaged. Frame collapse/massive destruction. Little left standing	Doors and windows fail and result in lethal hazard	Majority of personnel suffer fatalities.
Very Low	Heavily damaged-onset of structural collapse: Major deformation of primary and secondary structural members, but progressive collapse is unlikely. Collapse of non-structural elements.	Glazing will break and is likely to be propelled into the building, resulting in serious glazing fragment injuries, but fragments will be reduced. Doors may be propelled into rooms, presenting serious hazards.	Majority of personnel suffer serious injuries. There are likely to be a limited number (10% to 25%) of fatalities.
Low	Damaged – unreparable. Major deformations of non-structural elements and secondary structural members and minor deformation of primary structural members, but progressive collapse is unlikely.	Glazing will break, but fall within 1 meter of the wall or otherwise not present a significant fragment hazard. Doors may fail, but they will rebound out and their frames, presenting minimal hazards.	Majority of personnel suffer significant injuries. There may be a few (<10%) fatalities.
Medium	Damaged – repairable. Minor deformations of non-structural elements and secondary structural members and no permanent deformations in primary structural members.	Glazing will break, but will remain in the window frame. Doors will stay in frames, but will not be reusable.	Some minor injuries, but fatalities are unlikely.
High	Superficially damaged. No permanent deformation of primary and secondary structural members or non-structural elements.	Glazing will not break. Doors will be reusable.	Only superficial injuries are likely.

Test Site

The HTL remote blast site, located in Lynn County, Texas, and 40 miles south of Lubbock, Texas, creates an ideal location for blast testing. Located amidst cotton fields, this site offers an area with flat terrain secluded from any houses or populated areas. This minimizes any possible problems that may arise with the public's concern with noise and general concerns of an explosion. Although secluded, the blast site offers electrical power which runs critical systems for blast testing.

Blast Reaction Chambers

HTL's blast reaction chambers construction consist of wide flange steel beams, steel tubes, and a 3/16" steel skin which encloses the blast reaction chambers as shown in Figure 3. HTL also placed 48" wide wing walls on the blast reaction chamber to reduce clearing effects on the reflecting surface as shown in Figure 3. The overall dimensions of the blast reaction chambers are twenty-eight (28) feet wide, including the wing wall, twelve (12) feet tall, and ten (10) feet deep. This depth encloses the blast reaction chambers to facilitate the housing of witness panels, structural members, and prevents air blast pressures from wrapping around the test specimen.

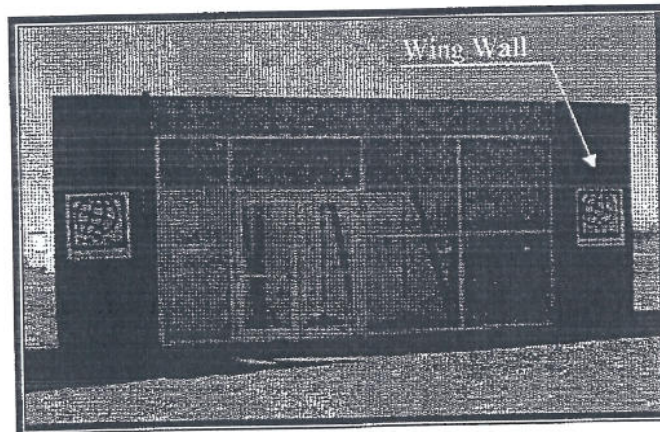

Figure 3: Blast Reaction Chamber

Test Specimens

HTL tested two glazing systems under a single air blast loading; the Kawneer “350HW Door with 1600 System 1 Framing with Project-Out Glassvent” (Figure 4), and the “8325TL Fixed over Project-Out Window” (Figure 5). Figure 4 shows a label schematic of the storefront test specimen. This label schematic is used as a reference for this report.

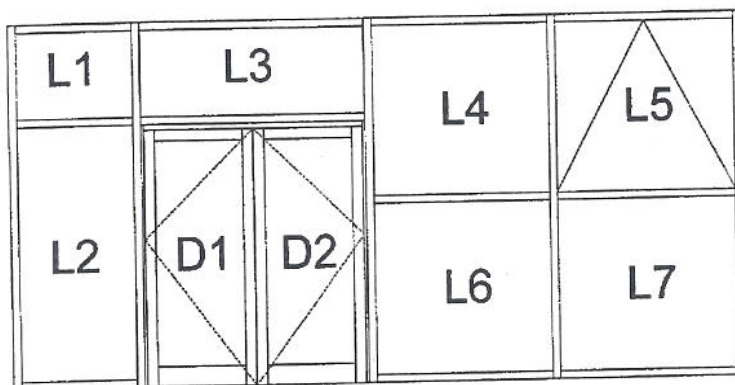

Figure 4: “350HW Door with 1600 System 1 Framing with Project-Out Glassvent” Wall System Label Schematic

Lites L2, L6, L7 and doors D1, D2 in the “350HW Door with 1600 System 1 Framing with Project-Out Glassvent” consisted of insulating units with an inboard lite constructed of two (2) 3.0 mm (1/8 in) laminated annealed plies with a 2.29 mm (0.090 in) Solutia Saflex interlayer, and the outboard lite consisted of a 6.0 mm (1/4 in) fully tempered lite sealing a 12.7 mm (0.5 in) airspace. Lites L1, L3, L4, and L5 consisted of insulating units with the inboard lite constructed with two (2) 3.0 mm (1/8 in) laminated annealed plies with a 0.090 in (2.29 mm) Solutia Saflex interlayer and an outboard lite of 6.0 mm (1/4 in) annealed sealing a 0.5 in (12.7 mm) airspace. Kawneer company wet glazed each lite with Tremco Proglaze SSG. A detailed set of drawings for the glazing and framing is provided in Appendix A.

Lite L5 served as an operable vent. Doors D1, and D2 served as functional doors at the time of the full scale arena blast test. Appendix A provides a detailed set of drawings of the door hardware and construction.

Kawneer Company also tested three (3) identical specimens of their "8325TL Fixed over Project-Out Window" in a single blast reaction chamber. Each window comprised of two lites, both insulating units. The inboard lite construction consisted of a laminated lite with two (1/8 in) annealed plies with a (0.060 in) Solutia Safelex interlayer and an outboard lite comprised of a 3.0 mm (1/4 in) annealed ply sealing a 1/2 in (12.7 mm) air space. Kawneer Company wet glazed each lite with Tremco Trimsil 600 for the weather seals and perimeter sills and all structure sealant consisted of Tremco Proglaze SSG. A detailed set of drawings for the glazing and framing is provided in Appendix A.

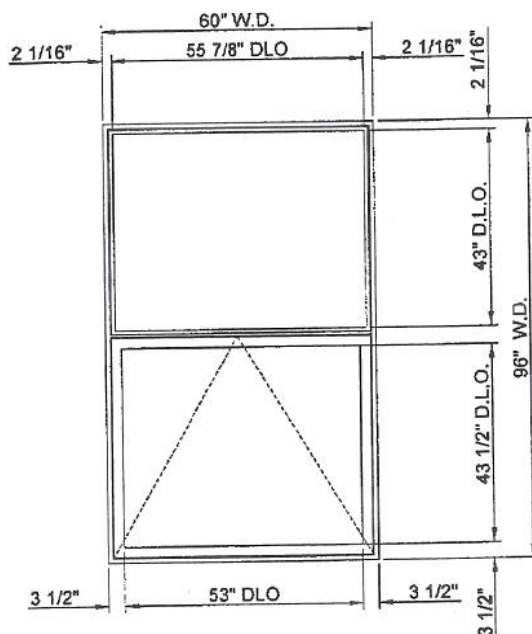

Figure 5: 8325TL Fixed over Project-Out Window

Witness Panels

HTL installed witness panels 121.5" from the interior face of the test specimen. Each panel consisted of two layers of material. The outer layer consisted of one-half (1/2) in. (12.7 mm) thick rigid foam plastic thermal insulation board composed of polyisocyanurate foam bonded to a durable white-matte non-glare aluminum facer and a reflective reinforced aluminum facer with a density of two (2) pounds per cubic foot.

The inside layer consisted of 1" extruded polystyrene insulation with a density of 1.8 pounds per cubic foot.

Data Acquisition System

HTL used a high speed data acquisition system with twelve (12) PCB reflected pressure transducers and one (1) PCB free-field pressure transducer. HTL mounted the reflected pressure transducers on the blast reaction chamber to determine the peak air blast pressure and positive phase impulse acting on the test specimen. The data acquisition system recorded seventy-five thousand (75,000) samples per second during the air blast pressure event.

HTL mounted reflected pressure transducers on each of the blast reaction chambers. For blast reaction chamber 1 through 3, HTL mounted two reflected pressure transducer on the wing wall located six (6) feet from the ground and thirty-four (34) inches from the outside of the wing wall. Also on these chambers, HTL mounted one (1) reflected pressure transducer on the midpoint twenty (20) inches from the top of the blast reaction chamber. For blast reaction chamber 4, HTL mounted two (2) pressure transducers at the midpoint between the middle and side windows and one (1) pressure transducer at the midpoint twenty-five (25) inches from the top of the blast reaction chamber.

Weather Conditions

On February 1, 2006, the test site's weather was clear and warm. No precipitation had fallen on the test date. HTL measured the ambient air temperature as 64°F (18°C) and the average temperature of the glazing as 43°F (6°C) less than five (5) minutes prior to the blast test.

Chamber Location

HTL utilized all four of their blast reaction chambers. Each chamber was placed tangent to a one hundred twenty-four (124) foot arc providing the required standoff distance for this specific test. Test Chamber 1, 2, and 3 (Figure 6) enclosed the "350HW Door with 1600 System 1 Framing with Project-Out Glassvent." Test Chamber 4

enclosed three (3) identical test specimens of the "8325TL Fixed over Project-Out Window." Figure 6 shows and labels the orientation of each blast reaction chamber.

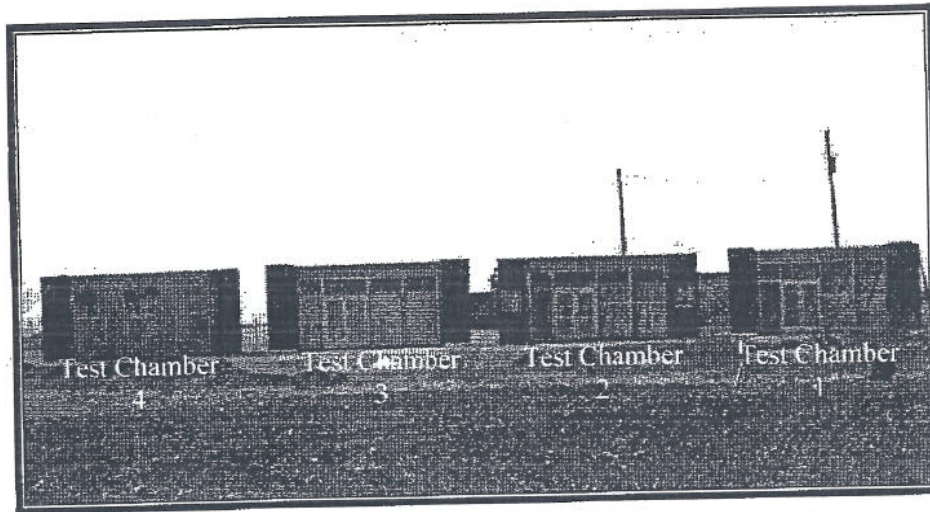

Figure 6: Blast Reaction Chamber Location

TEST RESULTS AND MAJOR FINDINGS

HTL performed a full scale arena blast test for Kawneer Company on February 1, 2006. This section presents the test results and major findings from the full scale arena blast test.

Peak Air Blast Pressure

HTL used a data acquisition system to record the pressure time history for each chamber in the blast. HTL then used this data to determine the peak air blast pressure. The data system recorded consistent peak air blast pressures on the reflecting surface. Theoretically, the peak air blast pressure acts equally over the reflecting surface at the time air blast event. Figure 7 shows the pressure time history for the full scale arena blast test.

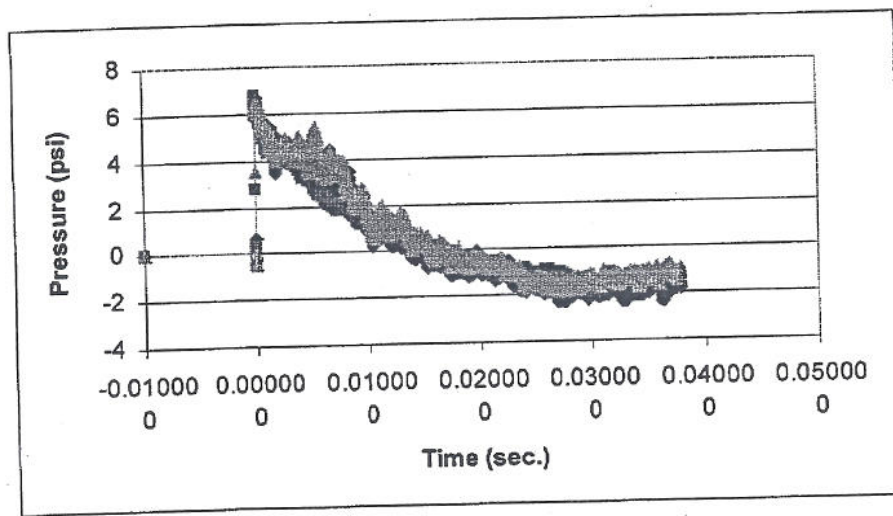

Figure 7: Airblast Pressure vs. Time Raw Data

Positive Phase Impulse

The positive phase impulse varies over the reflecting surface due to clearing effects. Higher pressures on the reflecting surface move toward the lower air pressure surrounding the blast reaction chamber causing a rarefaction wave on this surface. This creates lower impulses towards the edge of the reflecting surface and higher impulses towards the middle of the reflecting surface. HTL mounted two (2) pressure transducers on the wing walls and one (1) pressure transducer above the specimen in the centerline. These locations read the same peak positive phase air blast pressure but lower positive phase impulses due to their location. The positive phase impulse measured on the pressure transducers is slightly lower than what actually occurred on the test specimen.

Blast Reaction Chamber 1

Blast reaction chamber 1 housed a single storefront specimen of Kawneer, Company's "350HW Door with 1600 System 1 Framing with Project-Out Glassvent." This specimen underwent a peak overpressure of 6.62 psi (45.7 kpa) and a positive phase impulse of approximately 41.0 psi-ms (282.8 kpa-ms). Blast Reaction Chamber 1 is pictured in Figure 8 prior to the arena test and Figure 9 shows the test specimen post blast testing.

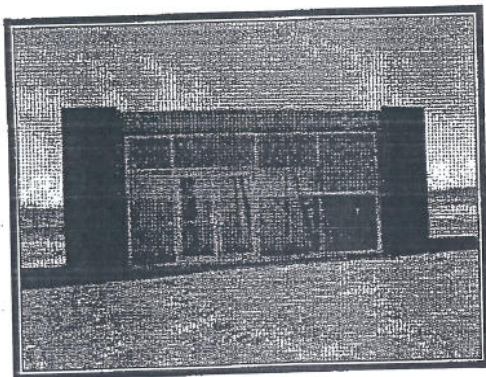

Figure 8: Blast Reaction Chamber 1,
Pre-Blast Test

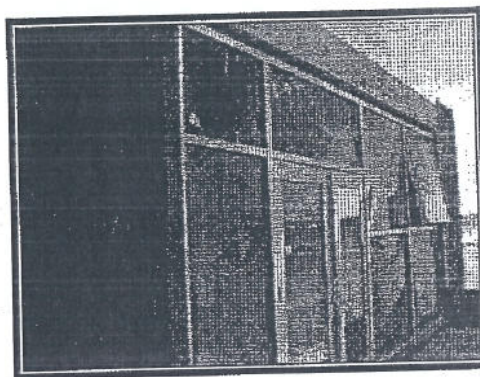

Figure 9: Blast Reaction Chamber 1,
Post-Blast Test

The specimen placed in blast reaction chamber 1 received a "*High Hazard*" rating per ASTM F1642-04, a "*Performance Condition 5*" per GSA, and a "*Very Low Level of Protection*" per UFC 4-010-01. Kawneer Company mistakenly glazed lite L4 inside-out thus placing the sacrificial lite, i.e. 1/4" (6.0 mm) annealed, toward the inside of the building. This caused glass shards from this lite to enter the occupied as shown in Figure 10. Kawneer Company glazed identical lites for L1, L3, L4, and L5. These identical lites performed similarly for all storefront specimens except the incorrect glazed lite L4 projected glass shards into the occupied space instead of outside the occupied space. This leads HTL to believe correct installation of Lite L4 in the storefront specimen placed in Blast Reaction Chamber 1 would have produced a "*Low Hazard*" per ASTM F1642-04 and a "*Performance Condition 3b*" per GSA since glass fragments would have been projected away from the occupied space. All other lites in this system behaved similarly to the other two (2) storefronts systems placed in the blast reaction chambers two (2) and three (3). Table 4 summarizes the "350HW Door with 1600 System 1 Framing with Project-Out Glassvent" individual lite sizes and the fractured lites in the system. The storefront system glazing fractured with no tears in the glazing interlayer and no pull out from the glass pocket. Also, the doors and operable vent rebounded outward from the frames but remained attached to the frame.

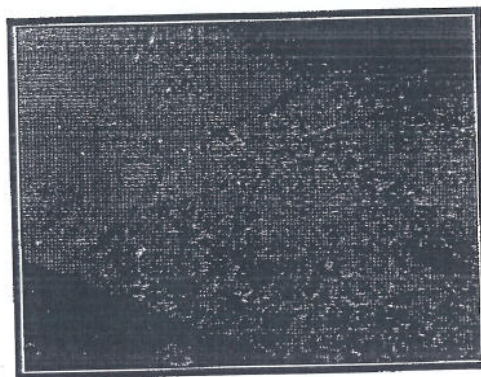

Figure 10: Glass Fragments from Incorrectly Glazed Lite.

Table 4: Storefront System Installed in Blast Reaction Chamber 1, Dimension and Fracture Summary

Label	Dimensions		Inboard Fractured?	Outboard Fractured?	Length of Tear Out in. (mm)
	Width* in. (mm)	Height* in. (mm)			
L1	37.5 (952.5)	28.4 (720.7)	No	Yes	None
L2	28.4 (720.7)	82.6 (2098.7)	Yes	Yes	None
L3	73.5 (1866.9)	28.4 (720.7)	Yes	Yes	None
L4*	57.5 (1460.5)	55.5 (1409.7)	Yes	Yes	None
L5	57.5 (1460.5)	55.5 (1409.7)	Yes	Yes	None
L6	57.5 (1460.5)	55.5 (1409.7)	Yes	Yes	None
L7	57.5 (1460.5)	55.5 (1409.7)	Yes	Yes	None
D1	28.8 (732.6)	73.2 (1859.0)	Yes	No	None
D2	28.8 (732.6)	73.2 (1859.0)	Yes	No	None

*Lite was installed backwards, i.e. laminated lite was installed as outboard lite.

*All dimensions are DLO.

Blast Reaction Chamber 2

Blast reaction chamber 2 housed a single specimen of Kawneer, Company's "350HW Door with 1600 System 1 Framing with Project-Out Glassvent". This specimen underwent a peak overpressure of 6.70 psi (46.2 kpa) and a positive phase impulse of 40.0 psi-ms (275.8 kpa-ms). Figure 11 shows the pre-test specimen and Figure 12 shows the post-test specimen.

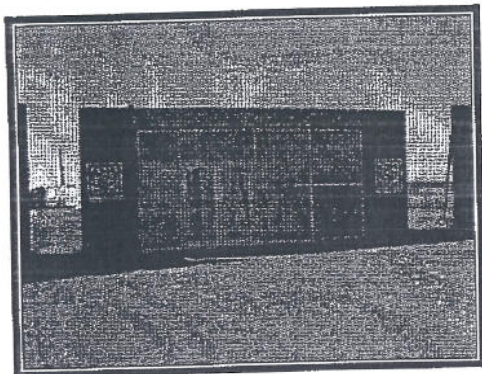

Figure 11: Blast Reaction Chamber 2,
Pre-Blast Test and Post-Blast Test

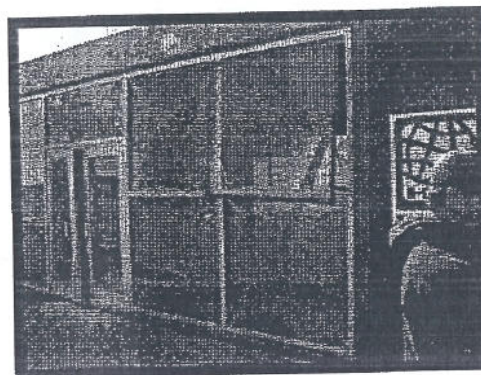

Figure 12: Blast Reaction Chamber 2,
Pre-Blast Test and Post-Blast Test

The storefront system placed in Blast Reaction Chamber 2 received a “*Low Hazard*” rating per ASTM F1642-04, a “*Performance Condition 3b*” per GSA, and far exceeded a “*Low Level of Protection*” per UFC 4-010-01. HTL collected fragments with a sum total united dimension greater than 10 in. (25 cm) on the floor between 40 in. (1 m) and 120 in. (3 m). There were zero perforations or fragment indents found in the witness panels. The storefront system glazing fractured with no tears in the glazing interlayer and HTL observed zero pull out from the glass pocket. The doors and operable vent rebounded outward from the frames but remained attached to the frame. Table 5 provides a summary of each individual lite in the storefront system.

Table 5: Storefront System Installed in Blast Reaction Chamber 2, Dimension and Fracture Summary

Label	Dimensions		Inboard Fractured?	Outboard Fractured?	Length of Tear Out in. (mm)
	Width* in. (mm)	Height* in. (mm)			
L1	37.5 (952.5)	28.4 (720.7)	No	No	None
L2	28.4 (720.7)	82.6 (2098.7)	Yes	No	None
L3	73.5 (1866.9)	28.4 (720.7)	Yes	Yes	None
L4	57.5 (1460.5)	55.5 (1409.7)	Yes	Yes	None
L5	57.5 (1460.5)	55.5 (1409.7)	Yes	Yes	None
L6	57.5 (1460.5)	55.5 (1409.7)	Yes	No	None
L7	57.5 (1460.5)	55.5 (1409.7)	Yes	Yes	None
D1	28.8 (732.6)	73.2 (1859.0)	Yes	Yes	None
D2	28.8 (732.6)	73.2 (1859.0)	Yes	Yes	None

*All dimensions are DLO.

Blast Reaction Chamber 3

Blast reaction chamber 3 housed a single storefront system of Kawneer Company's "350HW Door with 1600 System 1 Framing with Project-Out Glassvent". This specimen underwent a peak overpressure of 6.62 psi (45.7 kpa) and a positive phase impulse of 38.4 psi-ms (264.8 kpa-ms). Figure 13 shows the pre-test specimen and Figure 14 shows the post test specimen.

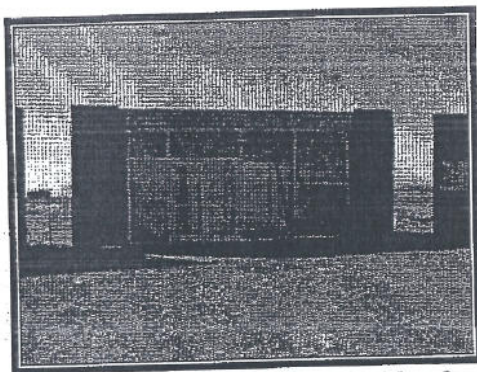

Figure 13: Blast Reaction Chamber 2, Pre-Blast Test

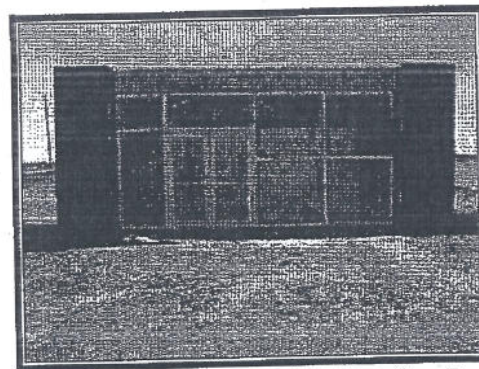

Figure 14: Blast Reaction Chamber 2, Post-Blast Test

The specimen placed in blast reaction chamber 3 received a “*Low Hazard*” rating per ASTM F1642-04, a “*Performance Condition 3b*” per GSA, and far exceeded a “*Low Level of Protection*” per UFC 4-010-01. HTL collected fragments with a sum total united dimension greater than 10 in. (25 cm) on the floor between 40 in. (1 m) and 120 in. (3 m). There were zero perforations or fragment indents found in the witness panels. The storefront system glazing fractured with no tears in the glazing interlayer and no pull out from the glass pocket. The doors and operable vent rebounded outward from the frames but remained attached to the frame. Table 6 provides a summary of each individual lite in the storefront system.

Table 6: Storefront System Installed in Blast Reaction Chamber 3: Dimension and Fracture Summary

Label	Dimensions		Inboard Fractured?	Outboard Fractured?	Length of Tear Out in. (mm)
	Width*	Height*			
	in. (mm)	in. (mm)			
L1	37.5 (952.5)	28.4 (720.7)	Yes	No	None
L2	28.4 (720.7)	82.6 (2098.7)	Yes	No	None
L3	73.5 (1866.9)	28.4 (720.7)	Yes	Yes	None
L4	57.5 (1460.5)	55.5 (1409.7)	No	No	None
L5	57.5 (1460.5)	55.5 (1409.7)	Yes	Yes	None
L6	57.5 (1460.5)	55.5 (1409.7)	Yes	Yes	None
L7	57.5 (1460.5)	55.5 (1409.7)	Yes	Yes	None
D1	28.8 (732.6)	73.2 (1859.0)	Yes	Yes	None
D2	28.8 (732.6)	73.2 (1859.0)	Yes	Yes	None

*All dimensions are DLO.

Blast Reaction Chamber 4

Blast reaction chamber 4 housed three (3) identical specimens of Kawneer Company’s “8325TL Fixed over Project-Out Windows.” These specimens underwent a peak overpressure of 6.63 psi (45.7 kpa) and a positive phase impulse of 38.7 psi-ms (266.9 kpa-ms). Figure 15 shows the window prior to blast testing and Figure 16 shows the Kawneer Company’s specimens after the blast test.

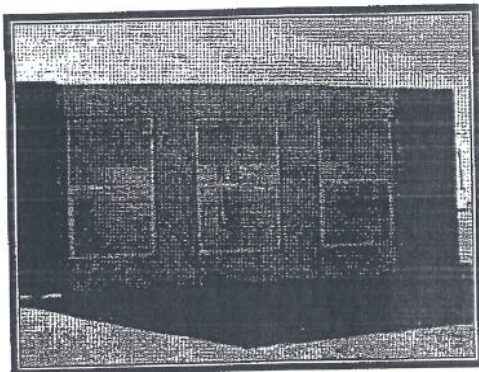

Figure 15: Blast Reaction Chamber 4,
Pre-Blast Test

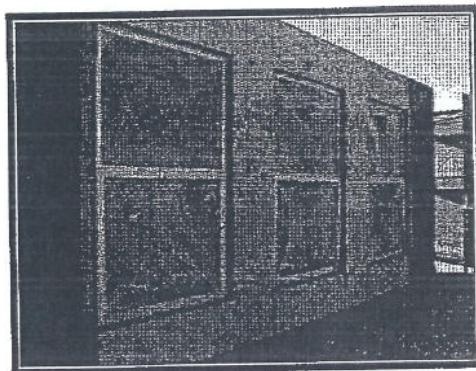

Figure 16: Blast Reaction Chamber 4,
Pre-Blast Test

The specimen placed in blast reaction chamber 4 received a "*Minimal Hazard*" rating per ASTM F1642-04 a "*Performance Condition 2*" per GSA, and a "*Medium Level of Protection*" per UFC 4-010-01. HTL collected zero fragments on the floor behind each specimen. Each lite fractured under blast loading but only produced glazing dust on the floor. There were zero perforations or fragment indents found in the witness panels. The window system glazing fractured with no tears in the glazing interlayer and HTL observed zero pull out from the glass pocket.

SUMMARY

The main objective of blast resistant glazing is to reduce or eliminate glass related injuries from an air blast pressure loading. In order to accomplish this objective, the glazing and frame must perform to its specifications. Kawneer, Company's "350HW Door with 1600 System 1 Framing with Project-Out Glassvent" performed well under air blast pressure loading. Incorrect installation of the lite L4 in the storefront system installed in Blast Reaction Chamber 1 created a "*High Hazard*" rating. HTL believes correct installation would have produced a "*Low Hazard*" rating, the same as the other two (2) identical storefront systems for this blast test.

Kawneer Company's "8325TL Fixed over Project-Out Windows" performed very well under air blast pressure loading. All the lites fractured but only produced glass dust and glazing slivers. Each lite's interlayer remained untornd and remained fully retained in the glass pocket.

ASTM F1642 is in the process of "loosing" their standard in regards to the sum total dimension of fragments. HTL believes under the new standard, the "350HW Door with 1600 System 1 Framing with Project-Out Glassvent" would receive a higher rating than under the ASTM F1642-04. At that time, HTL feels the hazard rating for the storefront system needs reevaluation after the release of the new ASTM F1642 standard.

Table 3: Summary of Test Results

Date:	February 1, 2006
Location:	Lynn County, Texas
Ambient Temperature:	64°F (18°C)
Specimen Temperature:	43°F (6°C)
Weather:	Clear
Charge Type:	Ammonium Nitrate Fuel Oil
Charge Weight:	300 lbs (136 kg)
Standoff Distance:	124 feet (37.8 m)
Peak Air Blast Pressure:	6.62 psi (45.7 kPa)
Measured Positive Phase Impulse:	Chamber 1: 41 psi-ms (282.8 kPa-ms) Chamber 2: 40 psi-ms (275.8 kPa-ms) Chamber 3: 38.4 psi-ms (275.8 kPa-ms) Chamber 4: 38.7 psi-ms (268.9 kPa-ms)

APPENDIX B

AIR BLAST PRESSURE-TIME HISTORIES

Air blast pressure time histories have not been included in the document per the request of Kawneer Company. To obtain this information, please submit a written statement requesting this information and proof of permission from Kawneer Company to Hurricane Test Laboratory, LLC. Hurricane Test Laboratory, LLC will then provide a copy of this information to the requesting party.

Kawneer IR501 & 350IR UFC Performance Test Report

BROADMOOR, L.L.C.

I hereby agree that the (equipment) (material) (article) shown and marked in this submittal is that proposed to be incorporated with contract number N69450-05-D-0096, is in compliance with the contract documents, can be installed in the allocated spaces, and is submitted for Government approval.

Robert White 5.12.09
 DQC Manager Date

Jeffery McCull 5/12/09
 QC Officer Date

DAMMON ENGINEERING INC

Project: Stennis ROF

Date: 5.12.09
 Reviewed: _____
 Reviewed as Noted: _____
 Revise and Resubmit: _____
 Rejected: _____
 Other: _____

Corrections or comments made on the shop drawings during this review do not relieve the contractor from compliance with requirements of the drawings and specifications. This check is only for review of the general conformance with the design concept of the project and general compliance with the information given in the contract documents. This contractor is responsible for: confirming and correlating all quantities and dimensions; selecting fabrication processes and techniques of construction; coordinating his or her work with that of all other trades and performing all in a safe and satisfactory manner.

Submitted Item: Kawneer Test Report Comments

BLAST TEST REPORT (UFL 4-010-02) — RIVERINE
ALUMINUM ENTRANCE FRAME & WINDOW PRODUCTS

1463
95438-76



FLORIDA | GEORGIA | TEXAS
BRANCH OFFICE
525 32nd Street
Lubbock, Texas 79404
806.797.2208
HTLTEST.COM

Test Report #: T049-1201-07-IR501
Specimen #: 1, 2, 3
Page: 1 of 15

Kawneer Company, Inc.
350IR Door in an IR501 Frame
Test Report #: T049-1201-07-IR501

1.0 MANUFACTURER'S IDENTIFICATION

- 1.1 Name of Applicant: Kawneer Company, Inc.
555 Guthridge Court
Norcross, GA 30092
Voice: 770.449.5555
Fax: 770.734.1560
- 1.2 Contact Person: Donnie Hunter

2.0 SCOPE OF WORK

Kawneer Company, Inc. retained HTL, LLC to conduct a full scale arena blast test per the requirements of ASTM F1642 and GSA-TS01-2003 on their 350IR Door in an IR501 Frame. HTL tested three (3) alike mock-ups exceeding the required minimum peak positive pressure of 5.8 psi and positive phase impulse of 41 psi-msec.

3.0 TESTING INFORMATION

- 3.1 Location: Lynn County, Texas
- 3.2 Test Date: June 24th, 2008
- 3.3 Test Time: 2:55 P.M. CST
- 3.4 Ambient Temperature: 93.0 °F
- 3.5 Relative Humidity: 24%
- 3.6 Weather Conditions: Clear

4.0 EXPLOSIVE CHARGE

- 4.1 Charge Type: Dyno Nobel Unimax[®]
- 4.2 Charge Weight: 420 lbs
- 4.3 Standoff Distance: 143 feet.

5.0 TEST SETUP

- 5.1 Data Acquisition System
HTL used a high speed data acquisition system with a system record time of one-hundred thousand (100,000) samples per second.
- 5.2 Reflected Pressure Transducers
HTL used seven (7) pressure transducers to measure the blast pressure time histories acting on the surface of the 350IR Door in an IR501 Frame.
- 5.3 Internal Pressure Transducers
HTL used one (1) pressure transducers to measure the internal blast pressure time history in each of the three (3) blast reaction chamber. These sensors were installed parallel to charge.

ENGINEER OF RECORD

Steven R. Samuels

9/15/08

Steven R. Samuels, P.E.

TX Reg. # 101259

9/15/2008



FLORIDA | GEORGIA | TEXAS
BRANCH OFFICE
 525 32nd Street
 Lubbock, Texas 79404
 806.797.2208
 HTLTEST.COM

Test Report #: T049-1201-07-IR501
 Specimen #: 1, 2, 3
 Page: 2 of 15

5.4 Free Field Pressure Transducers

HTL used two (2) free field pressure transducers to measure the free field air blast pressure time history. HTL placed these transducers at a distance greater than twenty-five (25) feet from any blast reaction chamber with a standoff distance of 143 ft.

5.5 Witness Panels

HTL used witness panels defined in ASTM F1642-04 Section 8.7.5. These witness panels also qualify for GSA-TS01-2003 Section 6.4.1. The witness panel makeup consisted of two layers of material. The outer layer consisted of one-half (1/2) inch thick rigid foam plastic thermal insulation board composed of polyisocyanurate foam bonded to a durable white-matte non-glare aluminum facer and a reflective reinforced aluminum facer with a density of two (2) pounds per cubic foot. The inside layer consisted of one (1) inch extruded polystyrene insulation with a density of 1.8 pounds per cubic foot.

6.0 PRODUCT IDENTIFICATION

- 6.1 Product Type: Storefront
- 6.2 Model Designation: 350IR Door in a IR501 Frame
- 6.3 Overall Size: 239 1/4" (w) x 119-5/8" (h)
- 6.4 Drawing: This test report is incomplete if not accompanied by Kawneer Company, Inc.'s drawing labeled "TUD575001B" (Sheets 1 through 8) bearing the digital stamp of Hurricane Test Laboratory, LLC with an original signature located in Appendix E.
- 6.5 Sample Source: Kawneer Company, Inc.

7.0 PRODUCT DESCRIPTION

- 7.1 Frame Construction
 The framing members were fabricated using the aluminum extrusions defined in Table 7.1.

Table 7.1: Aluminum Extrusion Details

Description	Part #	Overall Cross-Section	Alloy
Door Jamb with Fin	575-051	2.500" x 5.000" x 0.125"	6063-T6
HW Mullion	575-101	2.500" x 5.000" x 0.172"	
Pocket Filler	575-102	0.855" x 4.656" x 0.090"	
Standard Head/Sill	575-103	2.500" x 4.952" x 0.090"	
Glass Stop	575-104	1.523" x 1.628" x 0.075"	
Tubular Horizontal	575-115	2.500" x 4.952" x 0.090"	
HW Mullion	575-116	2.500" x 5.000" x 0.172"	
Pocket Insert	575-133	1.748" x 3.320" x 0.090"	
Deep Pocket Filler	575-135	1.575" x 4.656" x 0.090"	
HP Sill Flashing	575-157	1.500" x 5.188" x 0.090"	
HP Sill	575-158	2.500" x 4.952" x 0.090"	
HP Sill Cover	575-159	1.438" x 1.492" x 0.063"	
IR500/501 C.O.C. Transom Bar	575-059	2.500" x 4.952" x 0.090"	
IR501 Transom Bar Stop - Exterior	575-160	0.843" x 1.650" x 0.070"	
IR501 Transom Bar Stop - Interior	575-161	1.588" x 1.650" x 0.090"	
SAM II Door Stop	041-045	1.062" x 2.000" x 0.062"	
S/A Transom Bar Clip	450-103	1.250" x 4.150" x 0.125"	

ENGINEER OF RECORD

SKS

9/15/2008



FLORIDA | GEORGIA | TEXAS
BRANCH OFFICE
525 32nd Street
Lubbock, Texas 79404
806.797.2208
HTLTEST.COM

Test Report #: T049-1201-07-IR501
Specimen #: 1, 2, 3
Page: 3 of 15

7.1.1 Typical Frame Corner Construction

At each frame corner, the verticals ran through while the horizontal members were square cut, butted, and mechanically fastened to the verticals using #12 x 1" PHTF "AB" 300 series stainless steel screws.

7.1.2 Mullion Assembly

The mullions consisted of a single extrusion (Part# 575-116) and the pocket filler (Part# 575-102) snap fit into HW mullion extrusion.

7.1.3 Door Mullion Assembly

The door mullion consisted of a single extrusion (Part# 575-051) and the deep pocket filler (Part# 575-135) snap fit into the door jamb with fin extrusion.

7.1.4 Door Transom Jamb Assembly

The door mullion consisted of a single extrusion (Part# 575-051) with the deep pocket filler (Part# 575-135) and the pocket insert (Part# 575-133) snap fit into the door jamb with fin extrusion with the fin removed.

7.1.5 Head Assembly

The head consisted of a single extrusion (Part# 575-103) and the glass stop (Part# 575-104) snap fit into the head extrusion.

7.1.6 Sill Assembly

The sill consisted of a single extrusion (Part# 575-158) that was mechanically fastened to the HP sill flashing (Part# 575-157) using #12 x 7/16" PHTFS 400 series SS screws. The glass stop (Part# 575-104) and HP sill cover (Part# 575-159) were then snap fit into the HP sill extrusion.

7.1.7 Horizontal Assembly

The horizontal consisted of a single extrusion (Part# 575-115) and the glass stop (Part# 575-104) snap fit into the tubular horizontal extrusion.

7.1.8 Door Header Assembly

The head consisted of a single extrusion (Part# 575-059) that was mechanically fastened to the interior transom bar stop (Part# 575-161) using #10 x 1/2" FHTFS 300 series SS screws, the S/A transom bar clip (Part# 450-103) using 1/4-20 self drilling Grade 2 steel screws, and the SAM II door stop using #10 x 1-5/8" FHTF "B" 300 series SS screws. The exterior transom bar stop (Part# 575-160) snap fit into the C.O.C. transom bar.

7.1.9 Door Header Corner Construction

At each side of the door header, the verticals ran through while the horizontal members were square cut, butted, and mechanically fastened to the verticals using four (4) #10 x 1-19/32" PHTF 430 series SS screws and two(2) #12 x 1" PHTF "AB" 300 series SS screws.

ENGINEER OF RECORD

SPS

9/15/2008



FLORIDA | GEORGIA | TEXAS
BRANCH OFFICE
 525 32nd Street
 Lubbock, Texas 79404
 806.797.2208
 HTLTEST.COM

Test Report #: T049-1201-07-IR501
 Specimen #: 1, 2, 3
 Page: 4 of 15

7.1.10 Intermediate Mullion Reinforcement

Each interior mullion was reinforced with two (2) pieces of 1/2" x 1/2" x 8' A36 steel angle. The steel bar was attached to the mullion using two (2) #12 x 5/8" "B" fasteners on each side. The fasteners were located 4" from the top and bottom of the steel.

7.1.11 Interior Door Mullion and Transom Reinforcement

The interior door mullion and the door transom was reinforced with 1.096" x 4.494" x 0.134" Grade 50 steel. The steel was attached to the mullion and transom using two (2) #12 x 5/8" "B" fasteners on each side. The fasteners were located 4" from the top and bottom of the steel.

7.2 Door Construction

The framing members were fabricated using the aluminum extrusions defined in Table 7.2.

Table 7.2: Aluminum Extrusion Details

Description	Part #	Overall Cross-Section	Alloy
Door Stile	200-005	3.500" x 1.750" x 0.125"	6063-T6
Active Door Meeting Stile	200-006	3.500" x 1.750" x 0.125"	
Inactive Door Meeting Stile	200-007	3.562" x 1.750" x 0.125"	
Door Top Rail	200-023	3.500" x 1.724" x 0.125"	
Door Bottom Rail	200-032	6.500" x 1.724" x 0.125"	
Door Cross Rail	200-058	3.000" x 1.724" x 0.125"	
Exterior Door Glass Stop	575-043	1.356" x 0.351" x 0.070"	
Interior Door Glass Stop	575-045	1.354" x 1.359" x 0.188"	
Threshold	069-139	0.500" x 4.000" x 0.125"	
S/A T-Bar/Header w/ Weathering	450-502	1.750" x 4.452" x 0.125"	
Door Jamb Anchor Block	575-297	0.497" x 1.646" x 8.000"	

7.2.1 Typical Door Frame Corner Construction

Frame members were all square cut. The vertical jambs ran through while the horizontal members were square cut, butted and mechanically fastened to each vertical. The IR 501 horizontal members have internal extruded screw splines and were attached to the jambs with (3) # 12 x 1" SS PHTFS at each connection. The door jamb consisted of a tubular open back section with an extruded fin (part # 575-051). At each bottom corner, the vertical jamb ran through while the threshold was square cut, butted and mechanically fastened to each vertical jamb using one (1), jamb pivot assembly (Part #035-523 LH and 035-524 RH). Each pivot assembly was secured to the vertical jamb using three (3), #12-24" x 5/8" FHMS (part #028-350). The threshold (Part #069-139) was then placed over the pivot assembly and secured to the pivot assembly using two (2), #12-24 X 3/8" FHMS (Part # 028-845). In addition the threshold was secured directly to the opening as described in the installation section of this test report.

7.2.2 Door Panel Cross Rail Corner Construction

At each cross rail, the cross rail end is square cut, butted, and attached to the vertical stile and welded in place using one (1) 1/4" x 1-1/8" fillet weld that are applied to both webs of the cross rail.

ENGINEER OF RECORD

SPS

9/15/2008



FLORIDA | GEORGIA | TEXAS
BRANCH OFFICE
525 32nd Street
Lubbock, Texas 79404
806.797.2208
HTLTEST.COM

Test Report #: T049-1201-07-IR501
Specimen #: 1, 2, 3
Page: 5 of 15

7.2.3 Exterior Glass Stop

Each exterior glass stop (Part #575-043) is cut to the desired length and snap-fit to the adjacent door panel member. No sealant required.

7.2.4 Interior Fixed & Removable Glass Stop

Each interior glass stop (Part #575-045) is cut to the desired length and attached to the adjacent door panel member using a single row of #10 x 1/2" FHTFS (Part # 128-910). At the top and bottom rail four (4) fasteners, spaced 3" away from each end and two (2) equally spaced in between. At the vertical stiles nine (9) fasteners; spaced 3" away from each end and seven (7) equally spaced in between.

7.2.5 Miscellaneous Construction

A continuous aluminum sweep is applied along the bottom edge of each door panel (Part #200-795). Each sweep is secured to the bottom rail of the door panel using six (6), #6 x 3/4" PHTFS. A continuous adjustable astragal (Part #200-496) is applied to the lock stile of the active door panel using a single row of #6 x 11/16" FHSMS (part # 128-439) spaced 3.984, (4) at 9.562, 10.750, (4) at 8.750" on center thereafter. One flat spring was included at each fastener location.

7.3 Glazing Details

7.3.1 Glazing Materials

7.3.1.1 Type 1

This glazing consisted of an annealed glass lite with an overall thickness of 9/16" (nominal) constructed using the following components.

- 1/4" Annealed (Outboard)
- 0.090" Solutia Saflex® PVB Inner Layer
- 1/4" Annealed (Inboard)

7.3.1.2 Type 3

This glazing consisted of an annealed glass lite with an overall thickness of 1-5/16" (nominal) constructed using the following components.

- 1/4" Annealed (Outboard)
- 1/2" Air Space
- 1/4" Annealed
- 0.060" Solutia Saflex® PVB Inner Layer
- 1/4" Annealed (Inboard)

7.3.1.3 Type 4

This glazing consisted of an aluminum composite panel with an overall thickness of 1-5/16" (nominal) constructed using the following components.

- 4 mm Reynobond® with KEVLAR® Aluminum Composite Panel
- 1" x 1" Aluminum Bar Support

7.3.2 350IR Glazing Method

Lites L1, L2, and L3 were placed on a setting block, (Part # 027-342), and glazed from the exterior using a Tremco® Proglaze® SSG on the interior and a fixed gasket (Part# 027-563) on the exterior.

ENGINEER OF RECORD

S/S

9/15/2008



FLORIDA | GEORGIA | TEXAS
BRANCH OFFICE
 525 32nd Street
 Lubbock, Texas 79404
 806.797.2208
 HTLTEST.COM

Test Report #: T049-1201-07-IR501
 Specimen #: 1, 2, 3
 Page: 6 of 15

- 7.3.3 IR501 Dry Glazing Method
 Lites L6 and L8 were placed on a setting block, (Part # 127-070), and glazed from the exterior using a fixed gasket (Part# 127-121) on the interior and a fixed gasket (Part# 127-126) on the exterior.
- 7.3.4 IR501 Wet Glazing Method
 Lites L4, L5, and L7 were placed on a setting block, (Part # 127-070), and glazed from the exterior using Tremco® Proglaze® SSG on the interior and a fixed gasket (Part# 027-074) on the exterior.
- 7.3.5 Reynobond® with KEVLAR® Glazing Method
 Panels RB1 and RB2 were glazed from the exterior using Tremco® Proglaze® SSG on the interior and a fixed gasket (Part# 027-074) on the exterior.
- 7.3.6 Door Daylight Opening and Glass Bite
 Each lite of glass had a glass bite of 3/4" on all four sides. Reference Kawneer Company, Inc. drawing #TUD575001B for daylight openings located in Appendix B. HTL verified all daylight opening dimensions.
- 7.3.7 Frame Daylight Opening and Glass Bite
 Each lite of glass had a glass bite of 5/8" on all four sides. Reference Kawneer Company, Inc. drawing #TUD575001B for daylight openings located in Appendix B. HTL verified all daylight opening dimensions.

- 7.4 Frame Gaskets and Weather Stripping
 Table 7.3 provides a summary of the gaskets and weather stripping used in the test specimen.

Table 7.3: Gasket and Weather Stripping Details

Location	Part #	Material
Standard Push In Gasket	027-074	EPDM
Setting Block	127-070	
C.O.C. Transom Bar Setting Block	127-138	
Exterior Fixed Gasket	127-126	
Interior Fixed Gasket	127-121	
Slide In Spacer	127-011	Santropene
Sill to Sill Flashing Foam Tape	127-120	CCN Sponge
Water Deflector	451-105	Rigid PVC

- 7.5 Sealants Used
 Table 7.4 describes the location and sealant used in the test specimen.

Table 7.4: Sealants

Location	Sealant
Perimeter Sealant	Tremco Proglaze SSG
Door Frame Sealant	Tremco Tremsil 600
Door Panel Corner Sealant	None

ENGINEER OF RECORD

SPS

9/15/2008



FLORIDA | GEORGIA | TEXAS
BRANCH OFFICE
 525 32nd Street
 Lubbock, Texas 79404
 806.797.2208
 HTLTEST.COM

Test Report #: T049-1201-07-IR501
 Specimen #: 1, 2, 3
 Page: 7 of 15

7.6 Anchorage

Kawneer Company, Inc. secured the frame to the C12 x 25 A36 steel channel and 12" x 4" x 3/8" steel tube buck using #12 x 7/16" PHTFS aluminum anchors, 1/4-20 x 2" HH DrillFlex®, 1/4-20 x 2-1/2" DrillFlex®, 1/4-20 x 4" DrillFlex®, and 1/4"-20 x 2" FH Drill-flex® screws. Kawneer Company, Inc.'s drawing #TUD575001B shows anchorage locations and spacing for each anchor location. HTL verified the location, spacing, and type of anchor for each system tested to the drawing located in Appendix B.

8.0 AIR BLAST PRESSURE

8.1 Reflected Pressure Transducer Location

Figure 8.1 shows the locations of the reflected pressure transducers for the full scale arena blast test. HTL instrumented the test buck containing the three 8400TL windows. This buck was used as a transducer panel and accurately provided a means to measure the air blast pressure. This structure was same size, orientation, and standoff distance to the charge.

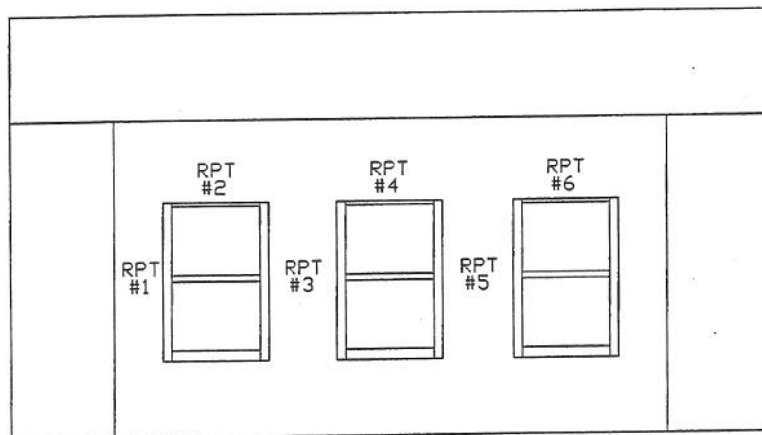

Figure 8.1: Reflected Pressure Transducer Locations.

8.2 Reflected Air Blast Pressure Results

The reflected pressure transducers were located on the test buck containing three 8400TL window specimens. This allowed HTL to observe the reflected blast pressure in areas where clearing effects have little influence; thus allowing a more accurate positive phase impulse data acquisition on the test specimen. RPT #1 was located in a region where the positive phase impulse begins to drop off due to clearing effects. The transducers located towards the middle of the reflecting surface showed consistent results, as predicted. Table 8.1 summarizes the reflected blast pressure results and Figure 8.2 shows the air blast pressure time histories.

Table 8.1: Reflected Air Blast Pressure Results

	RFP 1	RFP 2	RFP 3	RFP 4	RFP 5	RFP 6	Average
Peak Air Blast Pressure (psi)	7.56	7.77	7.93	7.82	7.87	7.39	7.72
Peak Positive Phase Impulse (psi-msec)	38.11	41.19	42.07	42.12	42.67	42.72	42.15
Positive Phase Duration (msec)	11.81	10.94	12.39	14.17	12.59	14.63	12.75

ENGINEER OF RECORD

SRS

9/15/2008



FLORIDA | GEORGIA | TEXAS
BRANCH OFFICE
 525 32nd Street
 Lubbock, Texas 79404
 806.797.2208
 HTLTEST.COM

Test Report #: T049-1201-07-IR501
 Specimen #: 1, 2, 3
 Page: 8 of 15

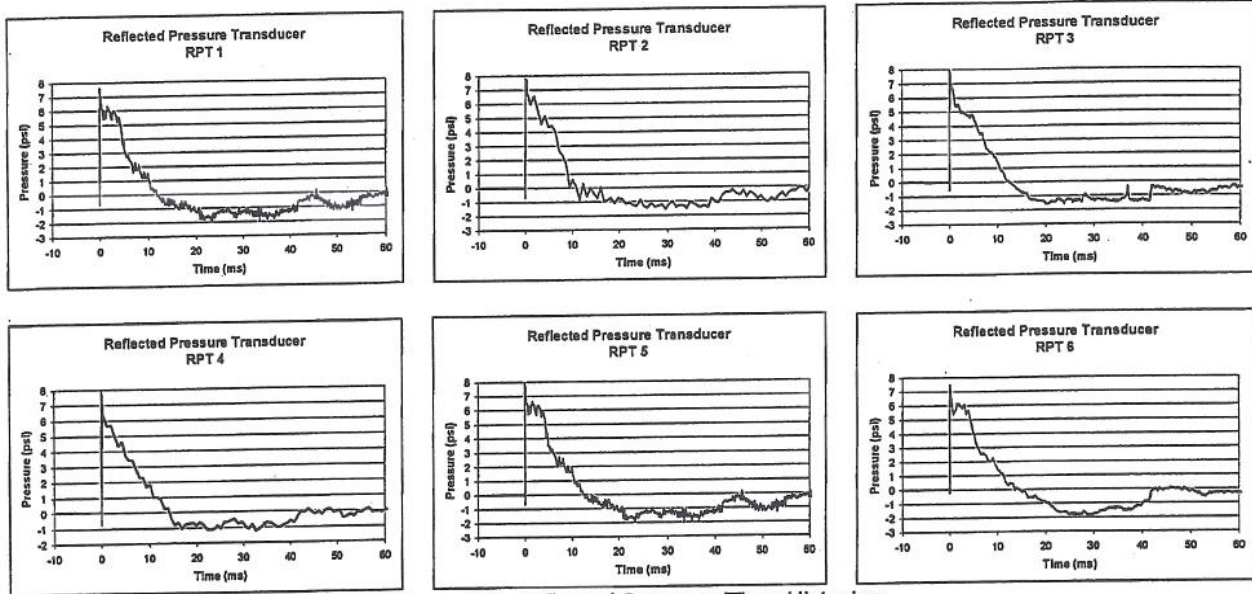

Figure 8.2: Reflected Pressure Time Histories

8.3 Free Field Air Blast Pressure Results

The free field pressure transducer produced consistent results between the two transducers. Table 8.2 provides the results obtained from the free field pressure transducers, and Figure 8.3 provides the free field air blast pressure time histories.

Table 8.2: Free Field Airblast Pressure Results

	FF 1	FF 2	Average
Peak Air Blast Pressure (psi)	3.6	3.4	3.5
Peak Positive Phase Impulse (psi-msec)	24.3	24.5	24.4
Positive Phase Duration (msec)	19.31	17.23	12.04

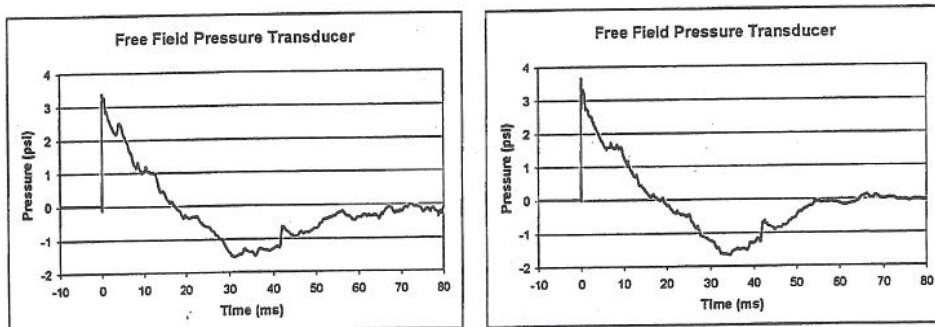

Figure 8.3: Free Field Airblast Pressure Time History

ENGINEER OF RECORD

SRS
9/15/2008



FLORIDA | GEORGIA | TEXAS
BRANCH OFFICE
525 32nd Street
Lubbock, Texas 79404
806.797.2208
HTLTEST.COM

Test Report #: T049-1201-07-IR501
Specimen #: 1, 2, 3
Page: 9 of 15

8.4 Internal Blast Pressure

HTL measured the internal blast pressure of blast reaction chamber. HTL obtained a maximum peak internal pressure for Specimens 1, 2, and 3 of 0.99 psi, 0.71 psi, and 0.56 psi respectively.

9.0 TEST RESULTS

9.1 350IR Door in IR501 Frame Test Specimen

Figure 9.1 shows a 350IR Door in an IR501 Frame. This figure also provides labels for each lite and Reynobond® with KEVLAR® Sheet. The prefix "L" indicates a lite of glass while "RB" indicates a Reynobond® with KEVLAR® panel. These labels are used as a reference in this test report for all three (3) test specimens.

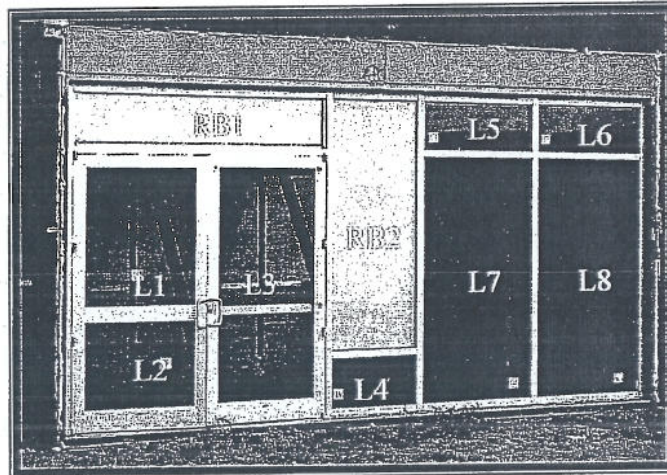

Figure 9.1: Pre-Blast Test Specimen with Lite and Framing Labels

9.2 Test Specimen #1 - Test Results

Tables 9.1 through 9.3 outline the response of the IR501 Storefront, 350IR Storefront Entrance Doors, and the Reynobond® with KEVLAR® panels under air blast pressure loading for Specimen #1. The tables also provide a glazing rating per the requirements of ASTM F1642-04 and GSA-TS01-2003. A complete photographic record of Specimen #1 is located in Appendix B.

ENGINEER OF RECORD

SRS
9/15/2008



FLORIDA | GEORGIA | TEXAS
BRANCH OFFICE
 525 32nd Street
 Lubbock, Texas 79404
 806.797.2208
 HTLTEST.COM

Test Report #: T049-1201-07-IR501
 Specimen #: 1, 2, 3
 Page: 10 of 15

Table 9.1: Specimen #1:
IR501 Storefront Test Results

IR501 Storefront	Response	Frame	The IR501 Storefront frame remained in the opening; however, most of the header anchors sheared. HTL observed a partial separation of the mullions between lites L4, RB2 and L5, L7. The mullion between lites L7 and L8 showed yielding at the midspan from the air blast pressure loading. The glass stops located above L6, below L7, and above RB2 detached from the frame and landed on the exterior of the blast reaction chamber.
		Glazing	None of the glazing fractured under air blast pressure loading and remained fully retained in the framing. HTL observed zero glazing dust, slivers, and fragments inside the occupied space. Since the glazing did not fracture, zero perforation or fragment indents were observed in the witness panel.
		Anchors	All of the top anchors sheared except for the two (2) end anchors for a total of twenty-eight (28) anchors that failed. The side and bottoms anchors so no sign of failure.
	Hazard Level	ASTM F1642-04	Minimal Hazard
		GSA-TS01-2003	Performance Condition 2
		UFC 4-010-02	Medium Level of Protection

Table 9.2: Specimen #1
305IR Entrance Door Test Results

350IR Entrance Door	Response	Frame	The left door detached from the mullion and landed on the exterior of the occupied space, the right door remained attached to the mullion. The bottom and two (2) middle hinges completely sheared from the frame on the left door. The right door hinges showed signs of stress but remained attached to the mullion. Both doors opened to the exterior. The door frames suffered minor permanent deformations. The panic devices and door closers remained attached to the doors.
		Glazing	The glazing L1 and L2 did not fracture. The glazing L3 fractured under air blast pressure loading. HTL observed a sum total united dimension of 2.75" inches past 40" from the interior face of the glazing which originated from Lite L3. HTL observed zero perforation or fragment indents in the witness panel.
		Anchors	The hinge anchors remained attached to the frame; however, three hinges failed during the air blast pressure loading.
	Hazard Level	ASTM F1642-04	Minimal Hazard
		GSA-TS01-2003	Performance Condition 2
		UFC 4-010-02	Medium Level of Protection

ENGINEER OF RECORD

SRS

9/15/2008



FLORIDA | GEORGIA | TEXAS
BRANCH OFFICE
 525 32nd Street
 Lubbock, Texas 79404
 806.797.2208
 HTLTEST.COM

Test Report #: T049-1201-07-IR501
 Specimen #: 1, 2, 3
 Page: 11 of 15

Table 9.3: Specimen #1
 Reynobond® with KEVLAR® Test Results

Reynobond® with KEVLAR®	Response		The Reynobond® with KEVLAR® panels remained in the glazing pocket. The glass stop located at the head of RB2 detached from the frame and landed on the exterior of the blast reaction chamber. The corners of RB2 shows stress lines and permanent deformations in the panel. RB1 showed only minimal signs of damage.
	Hazard Level	ASTM F1642-04	No Hazard
		GSA-TS01-2003	No Hazard
		UFC 4-010-02	High Level of Protection

9.3 Test Specimen #2 - Test Results

Tables 9.4 through 9.6 outline the response of the IR501 Storefront, 350IR Storefront Entrance Doors, and the Reynobond® with KEVLAR® panels under air blast pressure loading for Specimen #2. The tables also provide a glazing rating per the requirements of ASTM F1642-04 and GSA-TS01-2003. A complete photographic record of Specimen #2 is located in Appendix C.

Table 9.4: Specimen #2:
 IR501 Storefront Test Results

IR501 Storefront	Response	Frame	The IR501 Storefront frame remained in the opening; however, most of the header anchors sheared. HTL observed a partial separation of the mullion between lites L4, RB2 and L5, L7. The mullions located between lites L7 and L8 showed yielded at the midspan. The glass stop located above RB2 detached from the frame.
		Glazing	None of the glazing fractured under air blast pressure loading except the outboard lite L7. All glazing remained fully retained in the framing. Since none of the inboard lites fractured, HTL observed zero glazing dust, slivers, and fragments inside the occupied space. Zero perforation or fragment indents were observed in the witness panel.
		Anchors	All of the top anchors sheared except for the two (2) end anchors for a total of twenty-eight (28) anchors that failed. The side and bottoms anchors showed minimal damage.
	Hazard Level	ASTM F1642-04	Minimal Hazard
		GSA-TS01-2003	Performance Condition 2
		UFC 4-010-02	Medium Level of Protection

ENGINEER OF RECORD

SRS

9/15/2008



FLORIDA | GEORGIA | TEXAS
BRANCH OFFICE
 525 32nd Street
 Lubbock, Texas 79404
 806.797.2208
 HTLTEST.COM

Test Report #: T049-1201-07-IR501
 Specimen #: 1, 2, 3
 Page: 12 of 15

Table 9.5: Specimen #2
 350IR Entrance Door Test Results

350IR Entrance Door	Response	Frame	The left door detached from the mullion and landed on the exterior of the occupied space, the right door remained attached to the mullion. The bottom and two (2) middle hinges completely sheared from the frame on the left door. The right door hinges showed signs of stress but remained attached to the mullion. Both doors opened to the exterior. The door frames suffered minor permanent deformations. The panic devices and door closers remained attached to the doors.
		Glazing	The glazing L3 fractured under air blast pressure loading and remained fully retained in the framing. The remaining lites did not fracture. HTL observed minor glazing dust, slivers, and fragments inside the occupied space with a sum total united dimension of .75 inches. Zero perforation or fragment indents were observed in the witness panel.
		Anchors	The hinge anchors remained attached to the frame; however, three hinges fail during the air blast pressure loading.
	Hazard Level	ASTM F1642-04	Minimal Hazard
		GSA-TS01-2003	Performance Condition 3b
		UFC 4-010-02	Medium Level of Protection

Table 9.6: Specimen #2
 Reynobond® with KEVLAR® Test Results

Reynobond® with KEVLAR®	Response		The Reynobond® with KEVLAR® panels remained in the glazing pocket. The glass stop located at the head of RB2 detached from the frame and landed on the exterior of the blast reaction chamber. The corners of RB2 shows stress lines in the panel and panel had permanent deformation and "crinkling" in the panel. RB1 showed only minimal signs of stress.
	Hazard Level	ASTM F1642-04	No Hazard
		GSA-TS01-2003	Performance Condition 2
		UFC 4-010-02	High Level of Protection

9.4 Test Specimen #3 - Test Results

Tables 9.7 through 9.9 outline the response of the IR501 Storefront, 350IR Storefront Entrance Doors, and the Reynobond® with KEVLAR® panels under air blast pressure loading for Specimen #2. The tables also provide a glazing rating per the requirements of ASTM F1642-04 and GSA-TS01-2003. A complete photographic record of Specimen #2 is located in Appendix C.

ENGINEER OF RECORD

SRS

9/15/2008



FLORIDA | GEORGIA | TEXAS
BRANCH OFFICE
 525 32nd Street
 Lubbock, Texas 79404
 806.797.2208
 HTLTEST.COM

Test Report #: T049-1201-07-IR501
 Specimen #: 1, 2, 3
 Page: 13 of 15

Table 9.7: Specimen #3:
IR501 Storefront Test Results

IR501 Storefront	Response	Frame	The IR501 Storefront frame remained in the opening; however, many of the anchors sheared in the header. HTL observed a partial separation of the mullion between lites L4, RB2 and L5, L7. The mullions located between lites L6 and L7 showed damage and yielding at the midspan. The glass stop located above RB2, and below L4 and L8 detached from the frame.
		Glazing	None of the glazing fractured under air blast pressure loading except for L4 and glazing remained fully retained in the framing. HTL observed zero glazing dust, slivers, and fragments inside the occupied space. Since none of the inboard lites fractures, zero perforation or fragment indents were observed in the witness panel.
		Anchors	The first anchor on the top left of the header appeared to have minimal damage, the twenty (20) subsequent anchors located to the right of the first anchors completely sheared. The following nine (9) anchors showed only minimal damage. The side and bottom anchors showed only minimal damage.
	Hazard Level	ASTM F1642-04	Minimal Hazard
		GSA-TS01-2003	Performance Condition 2
		UFC 4-010-02	Medium Level of Protection

Table 9.8: Specimen #3
305IR Entrance Door Test Results

305IR Entrance Door	Response	Frame	Both doors remained attached to the mullion and opened toward the exterior of the occupied space. The top left hinge pin completely disengaged from the hinge. The middle hinges showed considerable damage but remained attached to the frame. The hinges on the right mullions showed minimal damage. The doors frame suffered minor permanent deformations. The panic device on the left door detached and landed inside the occupied with a maximum distance of 56.5 inches away from the interior side of the glazing. The left door panic device remained attached to the door.
		Glazing	None of the glazing fractured under air blast pressure loading and the glazing remained fully retained in the framing. HTL observed zero glazing dust, slivers, and fragments inside the occupied space. Since none of the lites fractured, zero perforation or fragment indents were observed in the witness panel.
		Anchors	The hinge anchors remained attached to the frame.
	Hazard Level	ASTM F1642-04	Minimal Hazard
		GSA-TS01-2003	Performance Condition 3b
		UFC 4-010-02	Medium Level of Protection

ENGINEER OF RECORD

SRS

9/15/2008



FLORIDA | GEORGIA | TEXAS
BRANCH OFFICE
 525 32nd Street
 Lubbock, Texas 79404
 806.797.2208
 HTLTEST.COM

Test Report #: T049-1201-07-IR501
 Specimen #: 1, 2, 3
 Page: 14 of 15

Table 9.9: Specimen #3
 Reynobond® with KEVLAR® Test Results

Reynobond® with KEVLAR®	Response		The Reynobond® with KEVLAR® panels remained in the glazing pocket. The glass stop located at the head of RB2 detached from the frame and landed on the exterior of the blast reaction chamber. The corners of RB2 shows stress lines in the panel and panel had permanent deformation and "crinkling" in the panel. RB1 showed only minimal signs of stress.
	Hazard Level	ASTM F1642-04	No Hazard
		GSA-TS01-2003	Performance Condition 2
		UFC 4-010-02	High Level of Protection

10.0 SUMMARY

Table 10.1 provides a summary of the test results for Kawneer Company, Inc.'s 350IR Door in a IR501 Frame.

Table 10.1: Summary of Test Results

Specimen #	Description	Hazard Rating			Internal Peak Air Blast Pressure (psi)	Average Peak Air Blast Pressure (psi-msec)	Average Positive Phase Impulse (psi-msec)
		ASTM 1642	GSA	UFC			
Specimen #1	IR501 Frame	Minimal Hazard	2	Medium Level of Protection	0.99	7.72	42.15
	350 IR Door	Minimal Hazard	3b	Medium Level of Protection			
	Reynobond® with KEVLAR®	No Hazard	2	High Level of Protection			
Specimen #2	IR501 Frame	Minimal Hazard	2	Medium Level of Protection	0.71	7.72	42.15
	350 IR Door	Minimal Hazard	3b	Medium Level of Protection			
	Reynobond® with KEVLAR®	No Hazard	2	High Level of Protection			
Specimen #3	IR501 Frame	Minimal Hazard	2	Medium Level of Protection	0.56	7.72	42.15
	350 IR Door	Minimal Hazard	2	Medium Level of Protection			
	Reynobond® with KEVLAR®	No Hazard	2	High Level of Protection			

11.0 CERTIFICATION AND DISCLAIMER STATEMENT

All tests performed on this test specimen were conducted in accordance with the specifications of the applicable codes, standards and test methods listed below by HTL, LLC. HTL, LLC does not have, nor does it intend to acquire or will it acquire, a financial interest in any company manufacturing or

ENGINEER OF RECORD

SRS

9/15/2008



FLORIDA | GEORGIA | TEXAS
BRANCH OFFICE
525 32nd Street
Lubbock, Texas 79404
806.797.2208
HTLTEST.COM

Test Report #: T049-1201-07-IR501
Specimen #: 1, 2, 3
Page: 15 of 15

distributing products tested at HTL. HTL is not owned, operated or controlled by any company manufacturing or distributing products it tests. This report is only intended for the use of the entity named in Section 1.0 of this report. Detailed assembly drawings showing wall thickness of all members, corner construction and hardware applications are on file and have been compared to the test specimen submitted. A copy of this test report along with representative sections of the test specimen will be retained at HTL for a period of three (3) years. All results obtained apply only to the specimen tested and they do indicate compliance with the performance requirements of the test methods and specifications listed in the following section.

12.0 APPLICABLE CODES, STANDARDS, AND TEST METHODS

ASTM F-1642-04: *Glazing and Glazing Systems subject to Airblast Loading*

GSA-TS01-2003: *US General Services Administration Standard Test Method for Glazing and Window Systems Subject to Dynamic Overpressure Loadings.*

* **UFC 4-010-02:** *DoD Minimum Anitferrosim Standards for Buildings*

13.0 WITNESSES (ALL OR PARTIAL)

Steven Samuels, P.E.	Operations Manager	HTL, LLC
Kyle Turner	Test Technician	HTL, LLC
Bart Master	Test Technician	HTL, LLC
Donnie Hunter	Product Manager	Kawneer Company, Inc.
Tanya Dolby, P.E.	Product Engineer	Kawneer Company, Inc.
Bill Hooper	Manager R&D	Kawneer Company, Inc.
Stephen Turano	Research Engineer	Kawneer Company, Inc.
Stan Steingold, P.E.	Application Engineer	Alcoa Architectural Products
Steve Austin	Technical Services Specialist	3M

ENGINEER OF RECORD

SLS

9/15/2008



FLORIDA | GEORGIA | TEXAS
BRANCH OFFICE
525 32nd Street
Lubbock, Texas 79404
806.797.2208
HTLTEST.COM

Test Report #: T049-1201-07-IR501
Specimen #: 1, 2, 3
Page: A1 of A2

**APPENDIX A:
PHOTOGRAPHIC RECORD**

ENGINEER OF RECORD

SRJ

9/15/2008



FLORIDA | GEORGIA | TEXAS
BRANCH OFFICE
525 32nd Street
Lubbock, Texas 79404
806.797.2208
HTLTEST.COM

Test Report #: T049-1201-07-IR501
Specimen #: 1, 2, 3
Page: A2 of A2

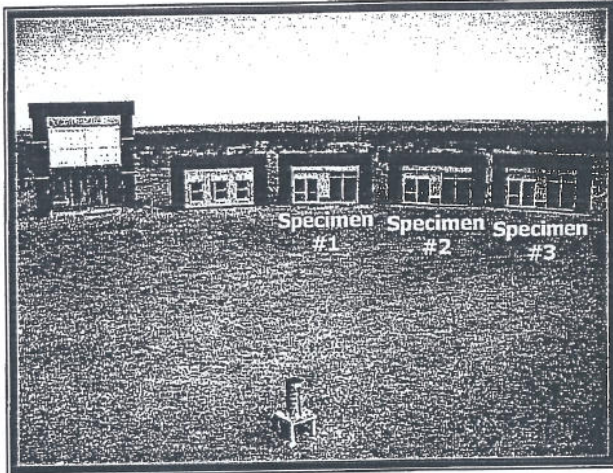

Range Setup

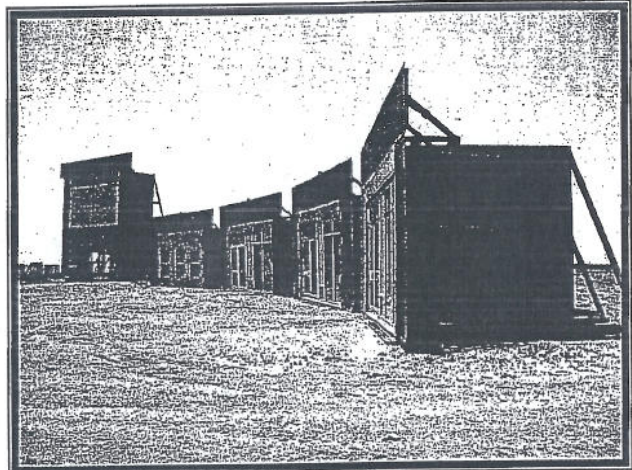

Range Setup

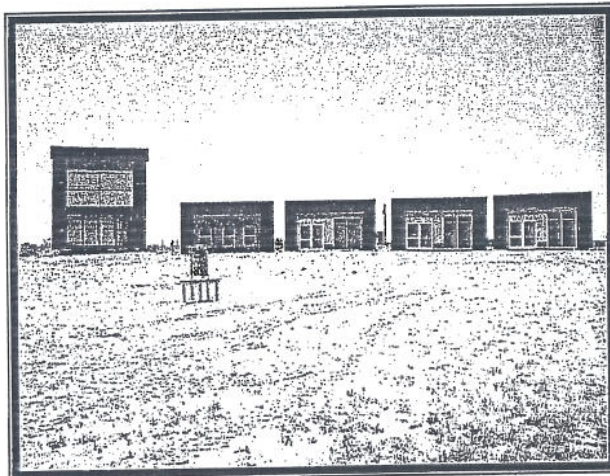

Range Setup

ENGINEER OF RECORD

SRS

9/15/2008

Glass Load Resistance Report

2/26/2009

Glazing Information **Project Details**

Edge Support: 4 Sides
 Glazing Angle: 90.0°
 Lite Dimensions:
 Width: 27.0 in.
 Height: 72.0 in.

Project Name: Riverine & Combatant Craft Oper Faci
 Project Location: Stennis Space Center, MS
 Comments: Bldg 2440 Door1, Requested by Rob Haidler, DeGeorg

Glass Construction

Single Glazed Lite (Annealed)
 Outboard Ply Thickness: 1/4 in.
 Interlayer Thickness: 0.090 in.
 Inboard Ply Thickness: 1/4 in.
 Nominal Lite Thickness: 1/2 in.

DOOR #1 BLDG 2440

Short Load Duration, Resistance, and Deflection Data

Load (~ 3 sec.)	50.0	psf
Load Resistance:	172	psf
Approximate center of glass deflection:	0.1	in.

Conclusion

Based on your design information, the load resistance is greater than or equal to the specified loading.

Statement of Compliance

Procedures followed in determining the resistance of this window glass are in accordance with ASTM E1300-02.

Disclaimer:

This software can be used to determine the load resistance of specified glass types exposed to uniform lateral loads of short or long duration subject to the following conditions:

- The glass is free of edge and surface damage and has been properly glazed in the opening in conformance with the manufacturer's recommendations.
- Procedures exist to determine load resistance for rectangular glass assemblies that are:
 Continuously supported along (1) all four edges, (2) all three edges, (3) two parallel edges, and (4) one edge.
- The software user has the responsibility of selecting the correct procedures for the required application from the software.
- The stiffness of members supporting any glass edge shall be sufficient that under design load, edge deflections shall not exceed L/175, where L denotes that length of the supported edge.
- The non-factored load values for laminated glass are representative of test data and calculations performed for polyvinyl butyral interlayer at a temperature of 50°C (122°F).

For other limiting conditions that may apply, refer to Section 5 of ASTM E1300 and local building codes.

Neither SDG nor PGMC guarantees and each disclaims any responsibility for any particular results relating to the use of the Window Glass Design-2002 Software Program. SDG and PGMC disclaim any liability for any personal injury or any loss or damage of any kind, including all indirect, special, or consequential damages and lost profits, arising out of or relating to the use of the Window Glass Design-2002 Software Program.

Prepared by: Steve Marino, PPG Ind on 2/26/2009

BROADMOOR, L.L.C.

I hereby agree that the (equipment) (material) (article) shown and marked in this submittal is that proposed to be incorporated with contract number N69450-05-D-0096, is in compliance with the contract documents, can be installed in the allocated spaces, and is submitted for Government approval.

Robert A. ... 5.12.09

DQC Manager

Date

Andy McAule 5/12/09

QC Officer

Date

DAMMON ENGINEERING INC

Date: 5.12.09 Project: Stennis ROK

Reviewed: _____
Revised and Resubmit: _____
Rejected: _____
Other: _____

Corrections or comments made on the shop drawings during this review do not relieve the contractor from compliance with requirements of the drawings and specifications. This check is only for review of the general conformance with the design concept of the project and general compliance with the information given in the contract documents. This contractor is responsible for confirming and correcting all quantities and dimensions; selecting fabrication processes and techniques of construction; coordinating his or her work with that of all other trades and performing all in a safe and satisfactory manner.

Submittal Item: Glass Lead Report Comments

Glass Load Resistance Report

2/26/2009

Glazing Information

Edge Support: 4 Sides
 Glazing Angle: 90.0°
 Lite Dimensions:
 Width: 30.0 in.
 Height: 42.0 in.

Project Details

Project Name: Riverine & Combatant Craft Oper Faci
 Project Location: Stennis Space Center, MS
 Comments: Bldg 2440 Wnd A, Requested by Rob Haidler, DeGeorg

Glass Construction

WINDOW "A" BLDG 2440

Double Glazed Insulating Unit

Outboard Lite [Heat Strengthened]

Nominal Lite Thickness: 1/4 in.

Inboard Lite [Annealed]

Outboard Ply Thickness: 1/4 in.

Interlayer Thickness: 0.090 in.

Inboard Ply Thickness: 1/4 in.

Nominal Lite Thickness: 1/2 in.

Short Load Duration, Resistance, and Deflection Data

Load (~ 3 sec.) 50.0 psf
 Load Resistance: > 210 psf
 Approximate center of glass deflection: 0.08 in.

use 210 psf since this is the maximum value that falls w/in scope of ASTM E1300

Conclusion

Based on your design information, the load resistance is greater than or equal to the specified loading.

Statement of Compliance

Procedures followed in determining the resistance of this window glass are in accordance with ASTM E1300-02.

Disclaimer:

This software can be used to determine the load resistance of specified glass types exposed to uniform lateral loads of short or long duration subject to the following conditions:

- The glass is free of edge and surface damage and has been properly glazed in the opening in conformance with the manufacturer's recommendations.
- Procedures exist to determine load resistance for rectangular glass assemblies that are:
 - Continuously supported along (1) all four edges, (2) all three edges, (3) two parallel edges, and (4) one edge.
- The software user has the responsibility of selecting the correct procedures for the required application from the software.
- The stiffness of members supporting any glass edge shall be sufficient that under design load, edge deflections shall not exceed $L/175$, where L denotes that length of the supported edge.
- The non-factored load values for laminated glass are representative of test data and calculations performed for polyvinyl butyral interlayer at a temperature of 50°C (122°F).

For other limiting conditions that may apply, refer to Section 5 of ASTM E1300 and local building codes.

Neither SDG nor PGMC guarantees and each disclaims any responsibility for any particular results relating to the use of the Window Glass Design-2002 Software Program. SDG and PGMC disclaim any liability for any personal injury or any loss or damage of any kind, including all indirect, special, or consequential damages and lost profits, arising out of or relating to the use of the Window Glass Design-2002 Software Program.

Prepared by: _____ on 2/26/2009

Steve Marino, PPG Ind

Glass Load Resistance Report

2/26/2009

Glazing Information

Edge Support: 4 Sides
 Glazing Angle: 90.0°
 Lite Dimensions:
 Width: 33.0 in.
 Height: 84.0 in.

Project Details

Project Name: Riverine & Combatant Craft Oper Faci
 Project Location: Stennis Space Center, MS
 Comments: Bldg 2440 Wnd C, Requested by Rob Haidler,
 DeGeorg

Glass Construction

Double Glazed Insulating Unit
 Outboard Lite [Heat Strengthened]
 Nominal Lite Thickness: 1/4 in.

Inboard Lite [Annealed]
 Outboard Ply Thickness: 1/4 in.
 Interlayer Thickness: 0.090 in.
 Inboard Ply Thickness: 1/4 in.
 Nominal Lite Thickness: 1/2 in.

WINDOW "C" BLDG 2440
 (lean-out observation)

Short Load Duration, Resistance, and Deflection Data

Load (~ 3 sec.) 50.0 psf
 Load Resistance: 129 psf
 Approximate center of glass deflection: 0.16 in.

Conclusion

Based on your design information, the load resistance is greater than or equal to the specified loading.

Statement of Compliance

Procedures followed in determining the resistance of this window glass are in accordance with ASTM E1300-02.

Disclaimer:

This software can be used to determine the load resistance of specified glass types exposed to uniform lateral loads of short or long duration subject to the following conditions:

- The glass is free of edge and surface damage and has been properly glazed in the opening in conformance with the manufacturer's recommendations.
- Procedures exist to determine load resistance for rectangular glass assemblies that are:
 - Continuously supported along (1) all four edges, (2) all three edges, (3) two parallel edges, and (4) one edge.
- The software user has the responsibility of selecting the correct procedures for the required application from the software.
- The stiffness of members supporting any glass edge shall be sufficient that under design load, edge deflections shall not exceed L/175, where L denotes that length of the supported edge.
- The non-factored load values for laminated glass are representative of test data and calculations performed for polyvinyl butyral interlayer at a temperature of 50°C (122°F).

For other limiting conditions that may apply, refer to Section 5 of ASTM E1300 and local building codes.

Neither SDG nor PGMC guarantees and each disclaims any responsibility for any particular results relating to the use of the Window Glass Design-2002 Software Program. SDG and PGMC disclaim any liability for any personal injury or any loss or damage of any kind, including all indirect, special, or consequential damages and lost profits, arising out of or relating to the use of the Window Glass Design-2002 Software Program.

Prepared by: _____ on 2/26/2009
 Steve Marino, PPG Ind

Glass Load Resistance Report

2/26/2009

Glazing Information

Edge Support: 4 Sides
 Glazing Angle: 90.0°
 Lite Dimensions:
 Width: 48.0 in.
 Height: 37.0 in.

Project Details

Project Name: Riverine & Combatant Craft Oper Faci
 Project Location: Stennis Space Center, MS
 Comments: Bldg 2441 Wnd B, Requested by Rob Haidler,
 DeGeorg

Glass Construction

WINDOW "B" BLDG 2441

Double Glazed Insulating Unit
 Outboard Lite { Heat Strengthened }
 Nominal Lite Thickness: 1/4 in.

Inboard Lite { Annealed }
 Outboard Ply Thickness: 1/4 in.
 Interlayer Thickness: 0.090 in.
 Inboard Ply Thickness: 1/4 in.
 Nominal Lite Thickness: 1/2 in.

Short Load Duration, Resistance, and Deflection Data

Load (~ 3 sec.) 50.0 psf
 Load Resistance: 182 psf
 Approximate center of glass deflection: 0.15 in.

Conclusion

Based on your design information, the load resistance is greater than or equal to the specified loading.

Statement of Compliance

Procedures followed in determining the resistance of this window glass are in accordance with ASTM E1300-02.

Disclaimer:

This software can be used to determine the load resistance of specified glass types exposed to uniform lateral loads of short or long duration subject to the following conditions:

- The glass is free of edge and surface damage and has been properly glazed in the opening in conformance with the manufacturer's recommendations.
- Procedures exist to determine load resistance for rectangular glass assemblies that are:
 Continuously supported along (1) all four edges, (2) all three edges, (3) two parallel edges, and (4) one edge.
- The software user has the responsibility of selecting the correct procedures for the required application from the software.
- The stiffness of members supporting any glass edge shall be sufficient that under design load, edge deflections shall not exceed L/175, where L denotes that length of the supported edge.
- The non-factored load values for laminated glass are representative of test data and calculations performed for polyvinyl butyral interlayer at a temperature of 50°C (122°F).

For other limiting conditions that may apply, refer to Section 5 of ASTM E1300 and local building codes.

Neither SDG nor PGMC guarantees and each disclaims any responsibility for any particular results relating to the use of the Window Glass Design-2002 Software Program. SDG and PGMC disclaim any liability for any personal injury or any loss or damage of any kind, including all indirect, special, or consequential damages and lost profits, arising out of or relating to the use of the Window Glass Design-2002 Software Program.

Prepared by: _____ on 2/26/2009
 Steve Marino, PPG Ind

Glass Load Resistance Report

2/26/2009

Glazing Information

Edge Support: 4 Sides
 Glazing Angle: 90.0°
 Lite Dimensions:
 Width: 46.0 in.
 Height: 46.0 in.

Project Details

Project Name: Riverine & Combatant Craft Oper Faci
 Project Location: Stennis Space Center, MS
 Comments: Bldg 2442 Wnd A, Requested by Rob Haidler,
 DeGeorg

Glass Construction

Double Glazed Insulating Unit
 Outboard Lite [Heat Strengthened]
 Nominal Lite Thickness: 1/4 in.

WINDOW "A" BLDG 2442
 Inboard Lite [Annealed]
 Outboard Ply Thickness: 1/4 in.
 Interlayer Thickness: 0.090 in.
 Inboard Ply Thickness: 1/4 in.
 Nominal Lite Thickness: 1/2 in.

Short Load Duration, Resistance, and Deflection Data

Load (~ 3 sec.) 50.0 psf
 Load Resistance: 164 psf
 Approximate center of glass deflection: 0.2 in.

Conclusion

Based on your design information, the load resistance is greater than or equal to the specified loading.

Statement of Compliance

Procedures followed in determining the resistance of this window glass are in accordance with ASTM E1300-02.

Disclaimer:

This software can be used to determine the load resistance of specified glass types exposed to uniform lateral loads of short or long duration subject to the following conditions:

- The glass is free of edge and surface damage and has been properly glazed in the opening in conformance with the manufacturer's recommendations.
- Procedures exist to determine load resistance for rectangular glass assemblies that are:
 - Continuously supported along (1) all four edges, (2) all three edges, (3) two parallel edges, and (4) one edge.
- The software user has the responsibility of selecting the correct procedures for the required application from the software.
- The stiffness of members supporting any glass edge shall be sufficient that under design load, edge deflections shall not exceed L/175, where L denotes that length of the supported edge.
- The non-factored load values for laminated glass are representative of test data and calculations performed for polyvinyl butyral interlayer at a temperature of 50°C (122°F).

For other limiting conditions that may apply, refer to Section 5 of ASTM E1300 and local building codes.
 Neither SDG nor PGMC guarantees and each disclaims any responsibility for any particular results relating to the use of the Window Glass Design-2002 Software Program.
 SDG and PGMC disclaim any liability for any personal injury or any loss or damage of any kind, including all indirect, special, or consequential damages and lost profits, arising out of or relating to the use of the Window Glass Design-2002 Software Program.

Prepared by: _____ on 2/26/2009
 Steve Marino, PPG Ind