

Steel City

Thinwall Conduit Fittings (EMT)

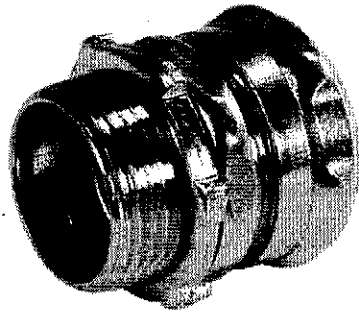

- ½" – 4" Concrete Tight
- Zinc Plated



Compression Connectors, Steel – Non-Insulated

"A" Cat#	Conduit Size	Inner Pack	Outer Pack
TC111A	½"	50	500
TC112A	¾"	50	250
TC113A	1"	25	100
TC114A	1¼"	–	25
TC115A	1½"	–	25
TC116A	2"	–	25
TC117A	2½"	–	10
TC118A	3"	–	5
TC119A	3½"	–	5
TC1110A	4"	–	5

Compression Connectors, Steel – Insulated

"A" Cat#	Conduit Size	Inner Pack	Outer Pack
TC711A	½"	50	500
TC712A	¾"	50	250
TC713A	1"	25	100
TC714A	1¼"	–	25
TC715A	1½"	–	25
TC716A	2"	–	25
TC717A	2½"	–	10
TC718A	3"	–	5
TC719A	3½"	–	5
TC7110A	4"	–	5

U.L. File No. E-16592

Steel City®

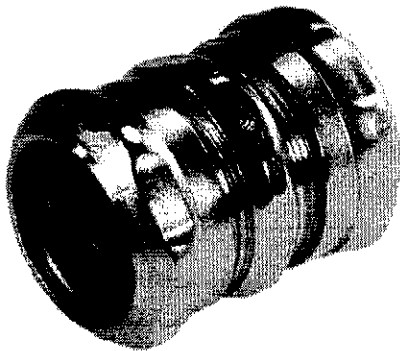

- ½" – 4" Concrete Tight
- Zinc Plated



Compression Couplings – Steel

"A" Cat#	Conduit Size	Inner Pack	Outer Pack
TK111A	½"	50	250
TK112A	¾"	50	250
TK113A	1"	25	100
TK114A	1¼"	–	25
TK115A	1½"	–	25
TK116A	2"	–	25
TK117A	2½"	–	10
TK118A	3"	–	5
TK119A	3½"	–	5
TK1110A	4"	–	5

U.L. File No. E-16592

Thomas & Betts

Steel City

Thinwall Conduit Fittings (EMT)

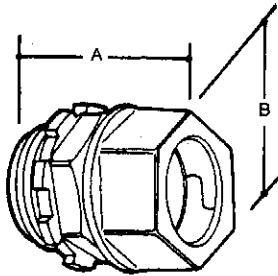

• ½" - 4" Concrete Tight

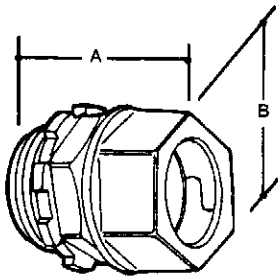

• ½" - 4" Concrete Tight

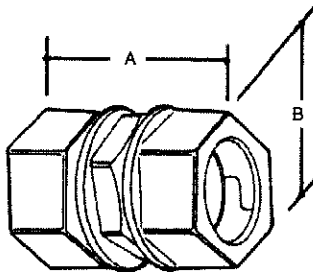

• ½" - 4" Concrete Tight

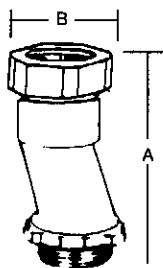

Compression Connectors – Die Cast Zinc, Noninsulated

Cat. No.	Conduit Size	A	B	Std. Ctn.
TC-211-SC	½"	1¼"	1"	500
TC-212-SC	¾"	1½"	1½"	250
TC-213-SC	1"	1¾"	1¾"	200
TC-214-SC	1¼"	1¾"	1¾"	100
TC-215-SC	1½"	1¾"	2¼"	40
TC-216-SC	2"	2½"	2½"	20
TC-217-SC	2½"	2¾"	3¼"	12
TC-218-SC	3"	2¾"	3¾"	12
TC-219-SC	3½"	2¾"	4¾"	10
TC-2110-SC	4"	2¾"	4¾"	6

U.L. File No. E-16592 – ½"-4"
CSA File No. LR-12798 – ½"-2"



Compression Connectors – Die Cast Zinc, Insulated

Cat. No.	Conduit Size	A	B	Std. Ctn.
TC-811-SC	½"	1¾"	¾"	500
TC-812-SC	¾"	1¾"	¾"	250
TC-813-SC	1"	1¾"	¾"	200
TC-814-SC	1¼"	1¾"	¾"	100
TC-815-SC	1½"	1¾"	2¼"	40
TC-816-SC	2"	2¼"	2½"	20
TC-817-SC	2½"	2¾"	3¼"	12
TC-818-SC	3"	2¾"	3¾"	12
TC-819-SC	3½"	2¾"	4¾"	10
TC-8110-SC	4"	2¾"	4¾"	6

U.L. File No. E-16592 – ½"-4"
CSA File No. LR-12798 – ½"-2"



Compression Couplings – Die Cast Zinc

Cat. No.	Conduit Size	A	B	Std. Ctn.
TK-211-SC	½"	1½"	1¾"	500
TK-212-SC	¾"	1¾"	1¾"	250
TK-213-SC	1"	1¾"	1¾"	200
TK-214-SC	1¼"	1¾"	2¾"	100
TK-215-SC	1½"	2¾"	2¾"	40
TK-216-SC	2"	2½"	2¾"	20
TK-217-SC	2½"	3¾"	3¾"	12
TK-218-SC	3"	3¾"	4½"	12
TK-219-SC	3½"	3¾"	5¼"	10
TK-2110-SC	4"	3¾"	5¾"	6

U.L. File No. E-16592 – ½"-4"
CSA File No. LR-12798 – ½"-1¼", 2½"-4"



Offset Compression Connectors – Die Cast Zinc

Cat. No.	Conduit Size	A	B	Std. Ctn.
TO-211-SC	¾" offset	2¾"	1"	200
TO-212	¾" offset	2.98"	1.16"	100

U.L. File No. E-16592

Thomas & Betts

Steel City

Thinwall Conduit Fittings (EMT)

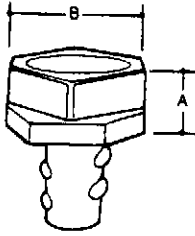

Combination Couplings – EMT to Flex Compression to Screw-In Type – Die Cast Zinc

Cat. No.	Trade Size	A	B	Std. Ctn.
TX-201	1/2"	0.84	1.10	500
TX-202	3/4"	0.95	1.30	250

E

Steel City®

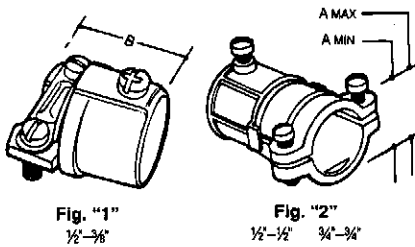
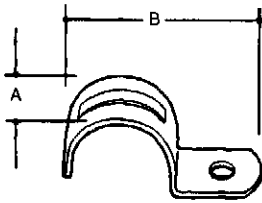

Fig. "1"
1/2"-3/8"

Fig. "2"
1/2"-1/2" 3/4"-3/4"

Combination Couplings – EMT to Flex Set Screw Type – Die Cast Zinc

Cat. No.	Fig. #	Trade Size	A-Min	A-Max	B	Std. Ctn.
TX-210	1	1/2" - 3/8"	0.15	0.61	1.16	250
TX-211	2	1/2" - 1/2"	0.60	1.00	1.71	250
TX-212	2	3/4" - 3/4"	0.78	1.20	1.93	200



- Steel
- Zinc Plated

One Hole Snap-Straps – Steel

Cat. No.	Conduit Size	A	B	Std. Ctn.
TS-101	1/2"	0.57"	1.79"	1000
TS-102	3/4"	0.62"	1.96"	500
TS-103	1"	0.75"	2.25"	500
TS-104	1 1/4"	0.88"	2.85"	250
TS-105	1 1/2"	0.99"	3.16"	100
TS-106	2"	1.10"	3.93"	50
HS-107	2 1/2"	1.28"	5.00"	25
HS-108	3"	1.28"	5.55"	25
HS-109	3 1/2"	1.28"	6.37"	10
HS-110	4"	1.28"	6.87"	10

Pipe Spacers for Thinwall or Heavywall – Die Cast

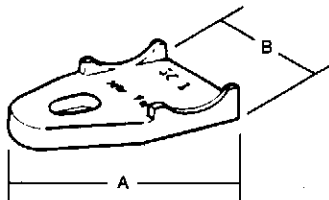

Cat. No.	Conduit Size	A	B	Std. Ctn.
CB-201	1/2"	2"	1"	1000
CB-202	3/4"	2 3/8"	1 1/8"	500
CB-203	1"	2 3/4"	1 5/8"	500
CB-204	1 1/8"	2 3/8"	1 1/2"	250
CB-205	1 1/2"	3 3/8"	1 5/8"	100
CB-206	2"	4 1/2"	2"	50

Thomas & Betts

Steel City

Thinwall Conduit Fittings (EMT)

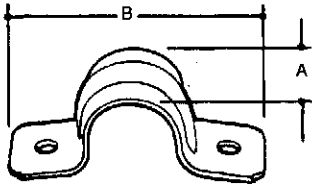

- Steel
- Zinc Plated

Steel City®

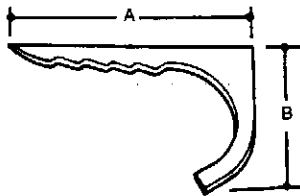

- Stamped Steel
- Zinc Plated

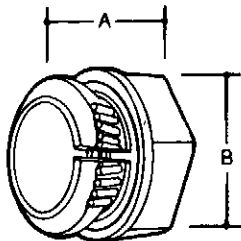

EMT Connector

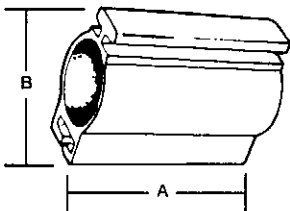

Space Cap

Two Hole EMT Straps – Steel

Cat. No.	Conduit Size	A	B	Std. Ctn.
TS-901	1/2"	0.56"	2.20"	250
TS-902	3/4"	0.62"	2.67"	200
TS-903	1"	0.68"	2.97"	100
TS-904	1 1/4"	0.75"	3.67"	50
TS-905	1 1/2"	0.88"	4.22"	200
TS-906	2"	1.00"	4.91"	25

Nail Strap – Steel

Cat. No.	Rigid/MC Size	EMT Size	Flex Size	A	B	Std. Ctn.
N-101-SC	—	1/2"	3/8"	1 1/8"	1 3/4"	1000
N-102-SC	1/2"	3/4"	1/2"	2 3/16"	1 7/32"	1000
N-103-SC	3/4"	1"	—	2 3/8"	1 5/32"	1000

EMT Connectors – Two Piece Type – Die Cast Zinc

Cat. No.	Trade Size	A	B	Std. Ctn.
TC-201-SC	1/2"	0.68	1.05	1000

UL File No. E16592

Space Caps – Plastic

Cat. No.	Conduit Size	A	B	Std. Ctn.
BT-501	1/2"	2 1/32"	1 3/64"	100
BT-502	3/4"	2 5/32"	1 4/64"	100
BT-503	1"	2 9/32"	1 1/4"	100
BT-504	1 1/4"	2 15/32"	2 3/64"	100
BT-505	1 1/2"	2 5/32"	3 1/32"	100

Thomas & Betts

Steel City

Rigid/Intermediate Grade Conduit Fittings

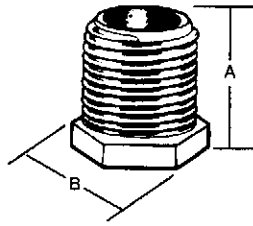

Conduit Nipples – Die Cast Zinc 1" Long

Cat. No.	Conduit Size	A	B	Std. Ctn.
HA-211	1/2"	1"	5/8"	1000
HA-212	3/4"	1"	1 1/8"	500
HA-213	1"	1"	1 1/8"	250

U.L. File No. E-1275 1/2" & 3/4" only



E

Steel City®

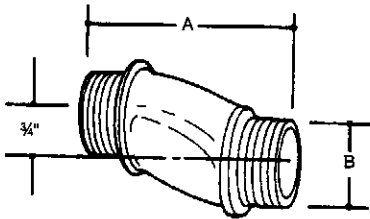

Offset Nipples – Die Cast Zinc

Cat. No.	Conduit Size	A	B	Std. Ctn.
HO-221	1/2"	2.60"	1.00"	100
HO-222	3/4"	2.62"	1.32"	100
HO-223	1"	2.68"	1.51"	100
HO-224	1 1/4"	2.85"	1.85"	50
HO-225	1 1/2"	2.88"	2.08"	50
HO-226	2"	3.19"	2.71"	20

3/4 offset.

U.L. File No. E-1275

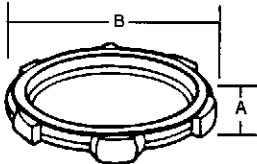

Locknuts – Steel/Zinc Plated

Cat. No.	Conduit Size	Dimensions (in.)		Std. Ctn.
		A (min.)	B (max.)	
LN-100-SC	3/8"	-	-	1000
LN-101-SC	1/2"	0.125"	1.140"	1000
LN-102	3/4"	0.140"	1.420"	1000
LN-103	1"	0.170"	1.770"	500
LN-104	1 1/4"	0.170"	2.281"	200
LN-105	1 1/2"	0.170"	2.598"	100
LN-106	2"	0.187"	3.175"	50
LN-107	2 1/2"	0.375"	3.562"	30
LN-108	3"	0.375"	4.250"	25
LN-109	3 1/2"	0.438"	4.803"	25
LN-110	4"	0.438"	5.402"	25
LN-111	5"	0.500"	6.674"	10
LN-112	6"	0.561"	7.934"	10

U.L. File No. E-1275



Thin Construction Locknuts-Steel/Zinc Plated

Cat. No.	Conduit Size	Unit Qty.	Std. Ctn.
SPLN-107	2 1/2"	30	30
SPLN-108	3"	25	25
SPLN-109	3 1/2"	25	25
SPLN-110	4"	25	25

*Not U.L. Listed

Thomas & Betts

Steel City

Rigid/Intermediate Grade Conduit Fittings

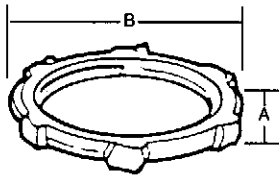

Locknuts – Die Cast Zinc

Cat. No.	Conduit Size	Dimensions (In.)		Std. Ctn.
		A (min.)	B (max.)	
LN-201	1/2"	0.125"	1.140"	2000
LN-202	3/4"	0.140"	1.420"	1000
LN-203	1"	0.170"	1.770"	1000
LN-204	1 1/4"	0.170"	2.281"	500
LN-205	1 1/2"	0.170"	2.598"	500
LN-206	2"	0.187"	3.175"	200
LN-207	2 1/2"	0.375"	3.562"	100
LN-208	3"	0.375"	4.250"	100
LN-209	3 1/2"	0.438"	4.803"	40
LN-210	4"	0.438"	5.402"	40

CSA File No. LR-12798
U.L. File No. E-1275

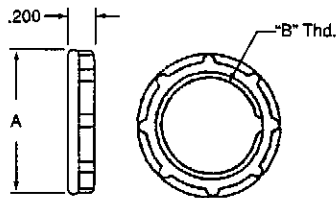

Locknuts-Nonmetallic

Cat. No.	Trade Size	"A" Dia.	"B" Thd.	Std. Ctn.
LN-501	1/2"	1.3	1/2-14	100
LN-502	3/4"	1.4	3/4-14	100
LN-503	1"	1.7	1-11 1/2	50

Material: Nylon 6/6
Color: Gray

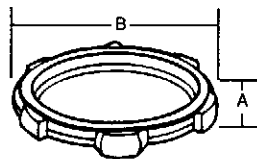

Sealing Locknuts – Steel/Zinc Plated

Cat. No.	Conduit Size	Dimensions (In.)		Std. Ctn.
		A (min.)	B (max.)	
LS-101	1/2"	0.26"	1.12"	1000
LS-102	3/4"	0.27"	1.37"	1000
LS-103	1"	0.28"	1.75"	500
LS-104	1 1/4"	0.32"	2.06"	200
LS-105	1 1/2"	0.32"	2.37"	100
LS-106	2"	0.32"	2.87"	50
LS-107	2 1/2"	0.32"	3.43"	50
LS-108	3"	0.32"	4.12"	50
LS-109	3 1/2"	0.32"	4.62"	50
LS-110	4"	0.32"	5.18"	25

U.L. File No. E-1275

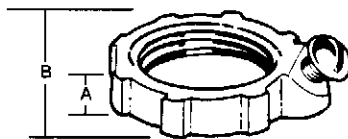

Grounding Locknuts – Malleable Iron/Zinc Plated

Cat. No.	Conduit Size	Dimensions (In.)		Std. Ctn.
		A (min.)	B (max.)	
LG-401	1/2"	0.125"	1.140"	100
LG-402	3/4"	0.140"	1.420"	100
LG-403	1"	0.170"	1.770"	50
LG-404	1 1/4"	0.170"	2.281"	50
LG-405	1 1/2"	0.170"	2.598"	50
LG-406	2"	0.187"	3.175"	25
LG-407	2 1/2"	0.375"	3.562"	10
LG-408	3"	0.375"	4.250"	10
LG-409	3 1/2"	0.438"	4.803"	50
LG-410	4"	0.438"	5.402"	5

U.L. File No. E-1275

Thomas & Betts

Steel City®

Steel City

Rigid/Intermediate Grade Conduit Fittings

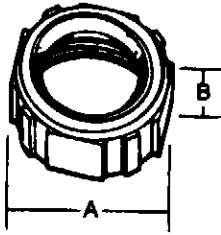

- 105°C thermoplastic liners.
- Heavy reinforced ribs.

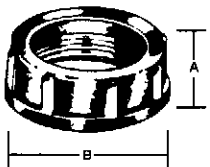
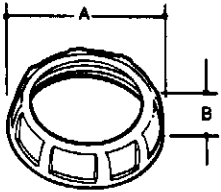

Conduit Bushings Die Cast Zinc – Insulated Metallic

Cat. No.	Conduit Size	A	B	Std. Ctn.
BU-801	½"	1.06	0.43	1000
BU-802	¾"	1.31	0.43	1000
BU-803	1"	1.59	0.48	500
BU-804	1¼"	1.96	0.56	250
BU-805	1½"	2.18	0.60	250
BU-806	2"	2.68	0.56	250
BU-807	2½"	3.25	0.90	50
BU-808	3"	3.87	0.85	25
BU-809	3½"	4.37	0.93	25
BU-810	4"	5.00	0.93	10

Conduit Bushings Die Cast Zinc – Heavy Reinforced Ribs

Cat. No.	Conduit Size	Dimensions (in.)		Std. Ctn.
		A (min.)	B (max.)	
BU-201	½"	1.05	0.37	1000
BU-202	¾"	1.32	0.37	1000
BU-203	1"	1.58	0.47	500
BU-204	1¼"	1.94	0.50	250
BU-205	1½"	2.20	0.52	250
BU-206	2"	2.69	0.52	250
BU-207	2½"	3.23	0.85	50
BU-208	3"	3.84	0.85	25
BU-209	3½"	4.35	0.85	25
BU-210	4"	5.02	0.85	10



Insulated Bushings – Thermoplastic

Cat. No.	Conduit Size	A	B	Std. Ctn.
BU-501	½"	1¾"	1¾"	400
BU-502	¾"	1¾"	1¾"	400
BU-503	1"	1¾"	1¾"	200
BU-504	1¼"	1¾"	1¾"	100
BU-505	1½"	1¾"	1¾"	100
BU-506	2"	1¾"	1¾"	60
BU-507	2½"	2¾"	3¾"	20
BU-508	3"	2¾"	3¾"	20
BU-509	3½"	3¾"	4¾"	5
BU-510	4"	3¾"	4¾"	5
BU-511	5"	4¾"	6¾"	5
BU-512	6"	1"	7¾"	5

U.L. File No. E-1275 ½"-4" only
Rated 105°C

Thomas & Betts

Steel City

Rigid/Intermediate Grade Conduit Fittings

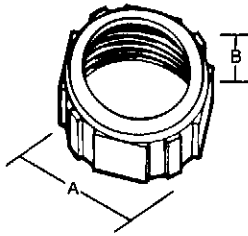

Bushings – Iron/Zinc Plated

Cat. No.	Conduit Size	A	B	Std. Ctn.
BU-401	1/2"	1 1/32"	7/16"	1000
BU-402	3/4"	1 1/4"	7/16"	1000
BU-403	1"	1 9/16"	7/2"	500
BU-404	1 1/4"	1 5/8"	7 1/2"	200
BU-405	1 1/2"	2 13/64"	9/16"	100
BU-406	2"	2 45/64"	5/8"	50
BU-407	2 1/2"	3 3/16"	19/32"	30
BU-408	3"	3 9/8"	2 5/32"	25
BU-409	3 1/2"	4 1/16"	2 3/32"	25
BU-410	4"	4 7/32"	1 5/16"	25
BU-411	5"	4 21/32"	1 5/16"	10

U.L. File No. E-1275

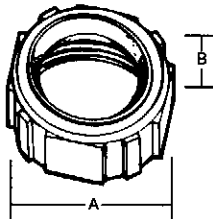

Insulated Bushings – Iron/Zinc Plated

Cat. No.	Conduit Size	A	B	Std. Ctn.
BI-901	1/2"	1 1/32"	1/2"	1000
BI-902	3/4"	1 1/4"	1/2"	1000
BI-903	1"	1 9/16"	5/8"	500
BI-904	1 1/4"	1 5/8"	1 9/32"	200
BI-905	1 1/2"	2 13/64"	5/8"	100
BI-906	2"	2 45/64"	5/8"	50
BI-907	2 1/2"	3 3/32"	4 1/4"	30
BI-908	3"	3 27/32"	4 1/8"	25
BI-909	3 1/2"	4 7/16"	7/8"	25
BI-910	4"	4 31/32"	2 9/32"	25

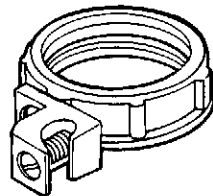

- 105°C Thermoplastic liners.
- Heavy reinforced ribs.

Grounding Bushings Die Cast Zinc – Insulated Metallic – With Aluminum Lay in Type Lug

Cat. No.	Trade Size	Grounding Lug Wire size		Std. Ctn.
		min.	max.	
BG-201	1/2"	14	4	500
BG-202	3/4"	14	4	500
BG-203	1"	14	4	250
BG-204A	1 1/4"	14	4	200
BG-204	1 1/4"	8	1/0	200
BG-205A	1 1/2"	11	4	100
BG-205	1 1/2"	8	1/0	50
BG-206A	1"	14	4	100
BG-206	2"	8	1/0	50
BG-207	2 1/2"	8	1/0	50
BG-207A	2 1/2"	6	250 MCM	50
BG-208	3"	8	1/0	50
BG-208A	3"	6	250 MCM	50
BG-209	3 1/2"	8	1/0	10
BG-209A	3 1/2"	6	250 MCM	10
BG-210	4"	8	1/0	10
BG-210A	4"	6	250 MCM	10

Thomas & Betts

Steel City

Liquidtight Flexible Nonmetallic Conduit Connectors and Tubing

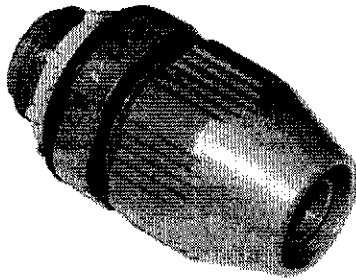

E

Steel City®

Connectors – Liquidtight Flex for Nonmetallic Conduit

Cat. No.	Trade Size	A ± .015 (0.40) Inch (mm)	B* ± .35 (0.90) Inch (mm)	C ± .015 (0.40) Across Corners Inch (mm)	Min. Throat Dia. D. Inch (mm)	E Thread NPT.	F Inch (mm) Approx.	Std. Ctn.
LT-500	¾"	.570	1.595 (40.51)	1.354	.417	½-14	1.880 (47.75)	100
LT-501	½"	.570	1.636 (41.55)	1.448	.550	½-14	1.986 (50.44)	100
LT-502	¾"	.582	1.757 (44.63)	1.740	.740	¾-14	2.212 (56.18)	50
LT-503	1"	.726	1.923 (48.84)	2.068	.940	1-11/12	2.508 (63.70)	50

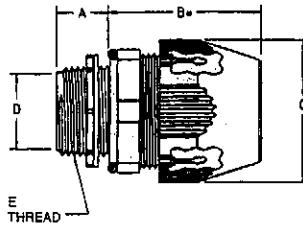

90° Connectors – Liquidtight Flex for Nonmetallic Conduit

Cat. No.	Trade Size	A ± .015 (0.40) Inch (mm)	B* ± .35 (0.90) Inch (mm)	C ± .015 (0.40) Across Corners Inch (mm)	Min. Throat Dia. D. Inch (mm)	E Thread NPT.	F Inch (mm) Approx.	Std. Ctn.
LT-590	¾"	(14.48)	1.380 (35.05)	(34.39)	(10.59)	½-14	1.880 (47.75)	50
LT-591	½"	(14.48)	1.489 (37.82)	(36.78)	(13.97)	½-14	1.986 (50.44)	50
LT-592	¾"	(14.78)	1.790 (45.47)	(44.20)	(18.80)	¾-14	2.212 (56.18)	50
LT-593	1"	(18.44)	2.104 (53.44)	(52.53)	(23.88)	1-11/12	2.508 (63.70)	25

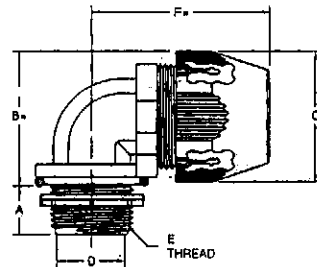

45° Connectors – Liquidtight Flex for Nonmetallic Conduit

Cat. No.	Trade Size	A ± .015 (0.40) Inch (mm)	B* ± .35 (0.90) Inch (mm)	C ± .015 (0.40) Across Corners Inch (mm)	Min. Throat Dia. D. Inch (mm)	E Thread NPT.	F Inch (mm) Approx.	Std. Ctn.
LT-540	¾"	(14.48)	2.012 (51.10)	(34.39)	(10.59)	½-14	1.534 (38.95)	50
LT-541	½"	(14.48)	2.092 (53.14)	(36.78)	(13.97)	½-14	1.590 (40.39)	50
LT-542	¾"	(14.78)	2.452 (62.28)	(44.20)	(18.80)	¾-14	1.821 (46.25)	50
LT-543	1"	(18.44)	2.684 (68.17)	(52.53)	(23.88)	1-11/12	2.034 (51.66)	25

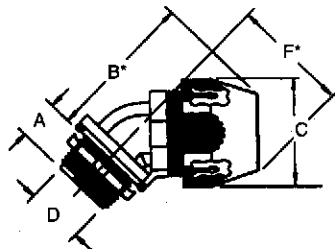

Standard Material/Finish

- Body/Gland—Nylon-Grey
- "O" Ring—Nitrile (Black)
- Locknut—Nylon
- Temp. Rating—80°C
- Material Flammability Rating: UL94-V2

Listed/Certified by:

- U.L. Listed (File # E23018)
- C.S.A. (File # LR52391)

Conforms To:

- Watertight requirements for Type 4

Thomas & Betts

Steel City

Liquidtight Flexible Nonmetallic Conduit Connectors and Tubing

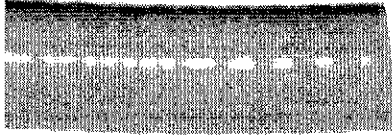

Liquidtight Flexible Nonmetallic Conduit (Type B) Outdoor XTRAFLEX® Raceway System

Cat. No. Series	Trade Size	I.D. IN.		O.D. IN.		Std. Ctn.
		Min.	Max.	Min.	Max.	
LTC038GY	3/8"	.484	.504	.690	.710	100
LTC050GY	1/2"	.622	.642	.820	.840	100
LTC075GY	3/4"	.820	.840	1.030	1.050	100
LTC100GY	1"	1.041	1.066	1.290	1.315	100
LTC125GY	1 1/4"	1.380	1.410	1.630	1.660	100
LTC150GY	1 1/2"	1.575	1.600	1.865	1.900	50
LTC200GY	2"	2.020	2.045	2.340	2.375	50

Color: Gray

Length: 100 ft. for LTC038GY thru LTC125GY 50 ft. for LTC150GY and LTC200GY

U.L. Listed: File E95745

U.L. Temperature Rating: 80°C dry, 60°C wet, 70°C oil. res. sunlight resistant, outdoor, direct burial.

CSA Certified: File LR 80349-2

CSA Temperature Rating: 75°C to -18°C

For use with Thomas & Betts LT38P, LT38M, LT500 series and Liquidtight Flexible Metal Conduit Fittings.

Material: PVC Helix reinforcement surrounded with flexible PVC.

Voltage Rating: 600V

Steel City®



Liquidtight Whip Assembly

Cat. No.	Conduit Size	Length	Wire Gauge	Std. Ctn.
LTWHIP 12-6-10	1/2"	6'	#10	6
LTWHIP 12-4-10	1/2"	4'	#10	6
LTWHIP 34-6-8	3/4"	6'	#8	6
LTWHIP 34-4-8	3/4"	4'	#8	6

Whip with metallic fittings – one straight, one 90°

LTWM 12-6-10	1/2"	6'	#10	6
LTWM 12-4-10	1/2"	4'	#10	6
LTWM 34-6-8	3/4"	6'	#8	6
LTWM 34-4-8	3/4"	4'	#8	6

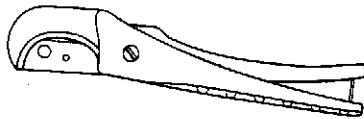

Conduit Cutter – For Nonmetallic Flexible Conduit

Cat. No.	Description
XF-CUT	For cutting NM flexible conduit up to 1"
XF-BLADE	Replacement blade for XF-CUT



Thomas & Betts

Steel City[®]

Liquidtight Fittings



Steel City[®]

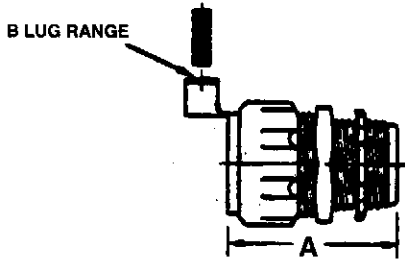

Versa Ground[™] Liquidtight Fittings

Cat. No.	Trade Size	A	B	Std. Ctn.
5331GR	3/8"	1 1/2"	14-4	100
5332GR	1/2"	1 9/16"	14-4	100
5333GR	3/4"	1 5/8"	14-4	25
5334GR	1"	2 1/16"	14-4	50
5231GR	3/8"	1 1/2"	14-4	100
5232GR	1/2"	1 9/16"	14-4	100
5233GR	3/4"	1 5/8"	14-4	25
5234GR	1"	2 1/16"	14-4	50
5231ALGR	3/8"	1 1/2"	14-4	100
5232ALGR	1/2"	1 9/16"	14-4	100
5233ALGR	3/4"	1 5/8"	14-4	50
5234ALGR	1"	2 1/16"	14-4	50

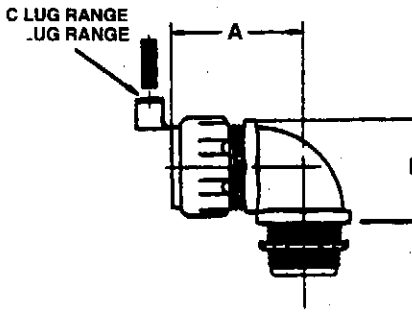

Versa Ground[™] Liquidtight Fittings – 90° Type

Cat. No.	Trade Size	A	B	C	Std. Ctn.
5351GR	3/8"	1 3/8"	1 1/4"	14-4	50
5352GR	1/2"	1 9/16"	1 3/8"	14-4	50
5353GR	3/4"	1 3/4"	1 5/8"	14-4	50
5354GR	1"	2 3/16"	2 1/8"	14-4	25
5251GR	3/8"	1 3/8"	1 1/4"	14-4	50
5252GR	1/2"	1 9/16"	1 3/8"	14-4	50
5253GR	3/4"	1 3/4"	1 5/8"	14-4	50
5254GR	1"	2 3/16"	2 1/8"	14-4	25
5251ALGR	3/8"	1 3/8"	1 1/4"	14-4	50
5252ALGR	1/2"	1 9/16"	1 3/8"	14-4	50
5253ALGR	3/4"	1 3/4"	1 5/8"	14-4	50
5254ALGR	1"	2 3/16"	2 1/8"	14-4	25

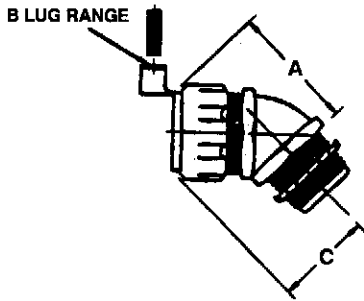

Versa Ground[™] Liquidtight Fittings

Cat. No.	Trade Size	A	B	C	Std. Ctn.
5341GR	3/8"	1 9/16"	14-4	1 1/16"	50
5342GR	1/2"	1 7/8"	14-4	1 3/8"	50
5343GR	3/4"	2 1/8"	14-4	1 3/8"	50
5344GR	1"	2 1/4"	14-4	1 3/4"	25
5241GR	3/8"	1 9/16"	14-4	1 1/16"	50
5242GR	1/2"	1 7/8"	14-4	1 3/8"	50
5243GR	3/4"	2 1/8"	14-4	1 3/8"	50
5244GR	1"	2 1/4"	14-4	1 3/4"	25

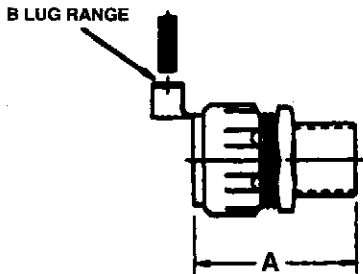

Liquidtight to Rigid External Ground Adapter

Cat. No.	Trade Size	A	B	Std. Ctn.
5271GR	3/8"	1 5/8"	14-4	50
5272GR	1/2"	1 7/8"	14-4	50
5273GR	3/4"	2 1/8"	14-4	50
5274GR	1"	1 7/8"	14-4	25

Thomas & Betts

Steel City®

Conduit and Pipe Hangers

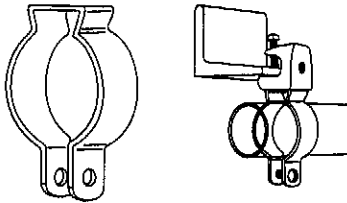

Without Bolt

All Steel City 6H Hanger Bolts include a combination Slot-Phillips Head.

For hanging conduit (rigid or EMT) and pipe. The 6H series hangers are fast, easy and economical to use. May be fastened directly to a #500 beam clamp through a hole in the base of the hanger by means of a 1/4-20 stove bolt or suspended on 1/4" hanger rod.

6H Series Conduit and Pipe Hangers – Without Bolt

Cat. No.	Size (in.)		Dimensions (in.)				Load Rating	Std. Ctn.
	Rigid Conduit or Pipe	EMT	A	B	C	D (dia.)		
6H0	3/8 - 1/2	1/2	3/4	.045	1 13/32	9/32	500	100
6H0-T	3/8 - 1/2	1/2	3/4	.045	1 23/32	9/32	500	100
6H1	3/4	3/4	7/8	.045	1 31/32	9/32	500	100
6H1-T	3/4	3/4	7/8	.045	2 9/32	9/32	500	100
6H2	1	1	7/8	.045	2 3/4	9/32	500	100
6H2-1/2	-	1 1/4	7/8	.045	2 23/32	9/32	500	100
6H3-SC	1 1/4	1 1/2	7/8	.045	2 7/8	9/32	500	100
6H4	1 1/2	-	1	.071	3 3/8	1 1/32	500	100
6H5	2	2	1 1/4	.071	3 29/32	1 1/32	500	50
6H6	2 1/2	-	1 1/4	.071	4 9/32	1 1/32	500	50
6H7	3	-	1 1/4	.071	5 1/8	1 1/32	500	25
6H8	3 1/2	-	1 1/4	.071	5 7/8	1 1/32	500	25
6H9	4	4	1 1/4	.071	5 7/8	1 1/32	500	10

* Add SS suffix to part number for stainless steel.

Load rating is 500 lbs. with a safety factor of 3. Available with or without closure bolt. Standard finishes: electrogalvanized and Type 302 Stainless Steel.



6H Series Conduit and Pipe Hangers – With Bolt

Cat. No.	Size (in.)		Dimensions (in.)				Load Rating	Std. Ctn.
	Rigid Conduit or Pipe	EMT	A	B	C	D (dia.)		
6H0-B	3/8 - 1/2	1/2	3/4	.045	1 13/32	9/32	500	100
6H0-TB	3/8 - 1/2	1/2	3/4	.045	1 23/32	9/32	500	100
6H1-B	3/4	3/4	7/8	.045	1 31/32	9/32	500	100
6H1-TB	3/4	3/4	7/8	.045	2 9/32	9/32	500	100
6H2-B	1	1	7/8	.045	2 3/4	9/32	500	100
6H2-1/2-B	-	1 1/4	7/8	.045	2 23/32	9/32	500	100
6H3-SC-B	1 1/4	1 1/2	7/8	.045	2 7/8	9/32	500	100
6H4-B	1 1/2	-	1	.071	3 3/8	1 1/32	500	100
6H5-B	2	2	1 1/4	.071	3 29/32	1 1/32	500	50
6H6-B	2 1/2	-	1 1/4	.071	4 9/32	1 1/32	500	50
6H7-B	3	-	1 1/4	.071	5 1/8	1 1/32	500	25
6H8-B	3 1/2	-	1 1/4	.071	5 7/8	1 1/32	500	25
6H9-B	4	4	1 1/4	.071	5 7/8	1 1/32	500	10

* Add SS suffix to part number for stainless steel. (not UL listed.)

Load rating is 500 lbs. with a safety factor of 3. Available with or without closure bolt. Standard finishes: electrogalvanized and Type 302 Stainless Steel.

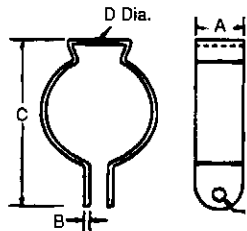

6H
Without bolt.



6H-B
With bolt and hex nut.



6H-T
Threaded without bolt.



6H-TB
Threaded with bolt.

5/16-18 x 1.5" HEX HEAD,
CUP POINT, HARDENED STEEL
CAP SCREW NOTE

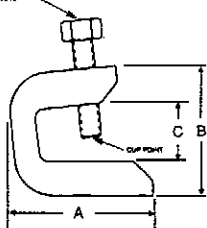

Beam Clamp

Cat. No.	Size	Tapped	Std. Ctn.
BC1-TB	1	1/4-20	250
BC2-TB	2 1/4	3/8-16	-

Material: Steel
Finish: Zinc Plated

Thomas & Betts

Steel City

Liquidtight Flexible Metal Conduit Connectors

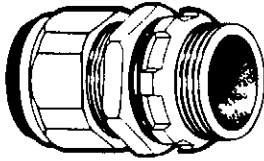

- 3/4"-1" - Steel.
- 1 1/4"-2" - Malleable Iron/Zinc Plated.

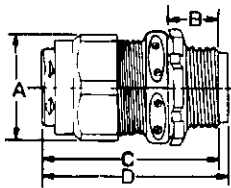

- 3/4"-1" - Steel.
- 1 1/4"-2" - Malleable Iron/Zinc Plated (with insulated throat).

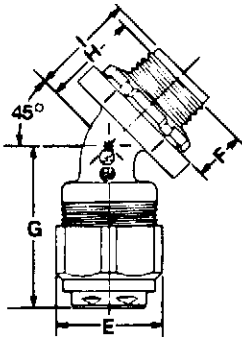
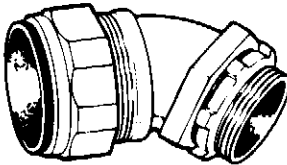

Straight Connectors

Cat. No.	Conduit Size	Diameter			Std. Ctn.
		A	B	C	
LT-100	3/4"	1 1/16"	1/2"	1 1/4"	100
LT-101	1/2"	1 3/16"	3/8"	1 1/8"	100
LT-102	3/4"	1 7/16"	9/16"	2 1/8"	50
LT-103	1"	1 3/4"	5/8"	2 3/8"	50
LT-104	1 1/4"	2 1/16"	1 1/16"	2 1/8"	25
LT-105	1 1/2"	2 3/4"	2 5/8"	2 5/8"	10
LT-106	2"	3 1/8"	2 5/8"	3 3/8"	5

CSA File No. LR-12798
U.L. File No. E-1275 -3/8"-4"



Straight Connectors

Cat. No.	Conduit Size	Diameter			Std. Ctn.
		A	B	C	
LT-700	3/4"	1 1/16"	1/2"	1 29/32"	100
LT-701	1/2"	1 3/16"	3/8"	1 21/32"	100
LT-702	3/4"	1 7/16"	9/16"	2 1/8"	50
LT-703	1"	1 3/4"	5/8"	2 9/16"	50
LT-704	1 1/4"	2 7/16"	1 1/16"	2 11/16"	25
LT-705	1 1/2"	2 3/4"	2 5/8"	2 7/8"	10
LT-706	2"	3 1/8"	2 5/8"	3 5/8"	5



45° Connectors - Malleable Iron/Zinc Plated

Cat. No.	Conduit Size	Dimensions				Std. Ctn.
		E	F	G	H	
LT-450	3/4"	1 1/16"	1/2"	1 19/16"	1 31/32"	50
LT-451	1/2"	1 3/16"	1/2"	1 5/8"	1"	50
LT-452	3/4"	1 7/16"	9/16"	1 7/8"	1 13/32"	50
LT-453	1"	1 3/4"	5/8"	2 1/8"	1 9/32"	25

CSA File No. LR-12798
U.L. File No. E-1275

45° Connectors - Malleable Iron/Zinc Plated (with insulated throat)

Cat. No.	Conduit Size	Dimensions				Std. Ctn.
		E	F	G	I	
LT-950	3/4"	1 1/16"	1/2"	1 19/16"	1 1/8"	50
LT-951	1/2"	1 3/16"	1/2"	1 5/8"	1 3/8"	50
LT-952	3/4"	1 7/16"	9/16"	1 7/8"	1 3/8"	50
LT-953	1"	1 3/4"	5/8"	2 1/8"	1 3/8"	25

Thomas & Betts

E
Steel City®

Steel City

Grounding Clamps/Connectors



Two-screw ground connection for armored ground wire.

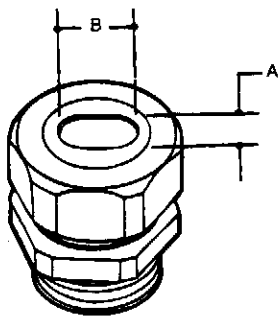

• For Type SE, Style U, Flat; 2 Insulating Conductors, 1 Bare.



Ground Clamps – Die Cast Zinc Alloy for Armored Ground Wire

Cat. No.	Conduit Conduit Size	Std. Ctn.
GA-203	½", ¾", 1"	250

U.L. File No. E-10661

Ground Clamps – Die Cast Zinc, Brass Colored

Cat. No.	Conduit Conduit Size	Std. Ctn.
GC-203-B	½", ¾", 1"	200

E

Steel City®

Water-Tight Connectors

Cat. No.	Trade Size	Fits Cable	Rubber Grommet Opening		Std. Ctn.
			A	B	
WT-203A	1"	3#8	.500	.750	100
WT-203B	1"	3#6	.563	.844	100
WT-203C	1"	3#4	.625	.938	100
WT-204A	1¼"	3#3	.625	1.000	50
WT-204B	1¼"	3#2	.580	.960	50
WT-204C	1¼"	3#1	.660	1.090	50
WT-204D	1¼"	3#1/0	.750	1.125	50
WT-205A	1½"	3#1/0 & 3#2/0	.735	1.240	20
WT-205B	1½"	3#2/0 & 3#3/0	.875	1.375	20
WT-205C	1½"	3#2/0 & 3#3/0	.938	1.438	20
WT-206A	2"	3#1/0 & 3#2/0	.735	1.240	20
WT-206B	2"	3#2/0 & 3#3/0	.875	1.375	20
WT-206C	2"	3#2/0 & 3#3/0	.938	1.438	20
WT-206D	2"	3#4/0	.890	1.550	20
WT-206E	2"	3#4/0	1.063	1.688	20
For Underground Feeder Cable					
UF-201	½"	2#14	.210	.440	250
UF-202	¾"	3#14	.220	.660	250

Thomas & Betts

Blackburn Grounding

Ground Rod Clamps

UL Listed for both copper-clad and galvanized ground rods.
Type JWR — Wide-Range Ground Rod Clamp

Blackburn Grounding

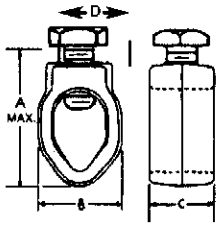

- UL Listed for direct burial in earth/concrete
- Constructed from bronze alloy and high-performance stainless steel bolt
- Provides wide range of connection sizes
- More than 300 lbs. torque capacity



CAT. NO.	NOMINAL ROD DIA.		WIRE RANGE				DIMENSIONS (IN.)				
	(IN.)	(MM.)	MAX.	MIN.	MAX. (MM ²)	MIN. (MM ²)	A (MAX.) BOLT	B	C	D	
JWR	3/8"	9.5	1/0 Str.	10 Sol.	53.4	5.2	1.535	1.050	.812	.652	
	1/2"	12.7	1/0 Str.	10 Sol.	53.4	5.2	1.535	1.050	.812	.652	
	3/4"	15.8	1/0 Str.	10 Sol.	53.4	5.2	1.535	1.050	.812	.652	
	1"	19.0	1/0 Str.	8 Sol.	53.4	8.3	1.535	1.050	.812	.652	

*3/4" rod not recognized/listed by UL.

Long bearing surface of clamp on ground wire secures ground connection.

Type JAB — Ground Rod Clamps



- Cast of high-strength corrosion-resistant copper alloy
- Both hex head bolts and socket set screws available
- UL Listed for direct burial

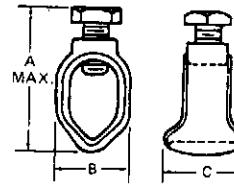

TYPE JABH



CAT. NO.	NOMINAL ROD DIA.		WIRE RANGE				DIMENSIONS (IN.)						
	SOCKET SET SCREW	HEX HEAD BOLT	(IN.)	(MM.)	MAX.	MIN.	MAX. (MM ²)	MIN. (MM ²)	A (MAX.) SOCKET SCREW	A (MAX.) HEX BOLT	SCREW THREAD SIZE UNC-2A	B	C
JAB12*	JAB12H	3/8"	12.7	2 Str.	10 Sol.	33.6	5.2	1 1/2"	2 3/8"	7/16-14	7/8"	3/4"	1 1/8"
JAB5B	JAB5BH	1/2"	15.8	1/0 Str.	8 Sol.	53.4	8.3	1 3/4"	2 1/4"	7/16-14	7/8"	1"	1 1/4"
JAB34	JAB34H	3/4"	19.0	1/0 Str.	8 Sol.	53.4	8.3	2"	2 1/2"	7/16-14	1 1/8"	1 1/4"	1 5/8"
—	JAB34C	3/4 + 1/2"	15.8 to 19.0	4/0 Str.	8 Sol.	95.0	8.3	—	2 1/2"	7/16-14	1 1/8"	1 1/2"	1 3/4"
JAB1	JAB1H	1"	25.0	4/0 Str.	8 Sol.	107.1	8.3	2 1/2"	3"	7/16-14	1 1/2"	1 1/8"	1 1/4"

*Not CSA listed Add suffix P to Cat. No. for tin-plated clamp.

A dependable ground connection offered at a substantial savings.

Type G — Budget-Line Ground Clamps

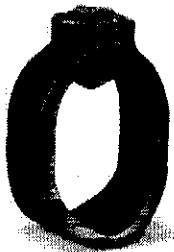

- Cast of high-strength corrosion-resistant copper alloy
- Furnished with hex head bolts
- Simplified, compact design makes lasting, trouble-free connection
- UL Listed for direct burial

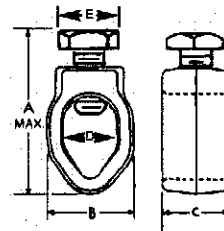

CAT. NO.	NOMINAL ROD DIA.		WIRE RANGE				DIMENSIONS (IN.)					
	(IN.)	(MM.)	MAX.	MIN.	MAX. (MM ²)	MIN. (MM ²)	A (MAX.) BOLT	SCREW THREAD SIZE UNC-2A	B	C	D	E
G3*	3/8"	9.5	4 Str.	10 Sol.	21.1	5.2	1"	7/16-18	1 1/8"	3/4"	3/4"	3/4"
G4	1/2"	12.7	2 Str.	10 Sol.	33.6	5.2	—	7/16-16	3/4"	3/4"	3/4"	1/2"
G5*	3/4"	15.8	2 Str.	10 Sol.	33.6	5.2	—	7/16-16	3/4"	3/4"	3/4"	1/2"
G6	1"	19.0	2 Str.	10 Sol.	33.6	5.2	—	7/16-16	1 1/8"	3/4"	3/4"	1/2"

*Not UL Listed *RUS Listed Add suffix P to Cat. No. for tin-plated clamp.

Thomas & Betts

United States
 Tel: 901.252.8000
 800.816.7899
 Fax: 901.252.1354

Canada
 Tel: 450.347.5216
 Fax: 450.347.1976

Technical Services
 Tel: 898.862.3289

Ground Clamps

Flexible copper strap makes alignment easy.

- For grounding rigid conduit systems
- Same features as "JP" clamp plus flexible copper strap
- Strap helps protect conduit system from water system vibrations
- Furnished with zinc-plated screws

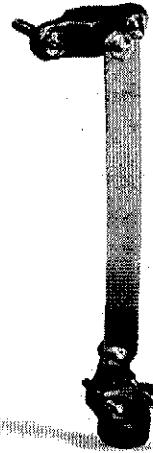

Cast Bronze Clamps with Copper Strap

CAT. NO.	CONDUIT SIZE	WATER PIPE SIZE	CONDUCTOR RANGE	
			MAX.	MIN.
JPS-12	1/2"	1/2"-1"	6 sol.	10 sol.
JPS-34	3/4"	1/2"-1"	2/0 str.	10 sol.
JPS-1	1"	1/2"-1"	3/0 str.	10 sol.

Add suffix C to Cat. No. to specify plating.

Blackburn Grounding

Connects copper ground wire to water pipe, copper tubing or ground rods.

- High strength, high conductivity copper alloy (over 80% copper)
- UL467 Listed for direct burial



Cast Bronze Ground Clamps

CAT. NO.	WATER PIPE SIZE	CONDUCTOR RANGE
JD	1/2"-1"	#2 str.-#10 str.
J2D	1"-2"	#2 str.-#10 str.

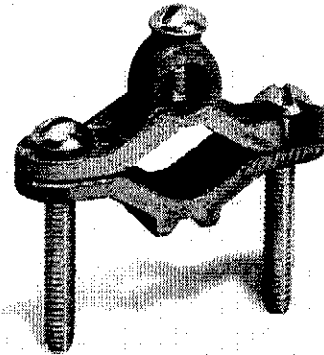

For connecting grounding conductor to water pipe or copper tube.

- Cast of high-strength, highly conductive copper alloy
- Screws plated for corrosion resistance
- UL Listed

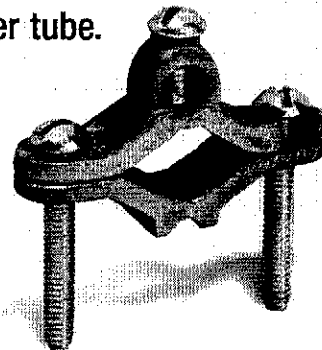

Type J — Cast Bronze Ground Clamps

CAT. NO.	WATER PIPE SIZE	CONDUCTOR RANGE		DIMENSIONS (IN.)		
		MAX.	MIN.	A (MAX.)	B	C
J	1/2 to 1	2 str.	10 sol.	2 3/4	2 1/4	3/4
J2BB	1 1/4 to 2	2 str.	10 sol.	3	3 3/4	1 1/4
J212A	2 1/2 to 4	4 str.	10 sol.	6	6 3/4	1 1/2
J6	4 1/4 to 6	4 str.	10 sol.	7 1/4	8 3/4	1 1/2

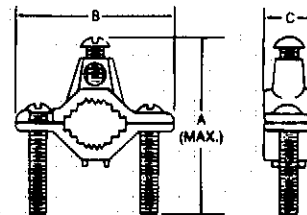

Rigid Nonmetallic Conduit – Schedule 40

Carlton® Rigid Nonmetallic Conduit (RNC), Fittings & Accessories

Carlton® manufactures the most complete line of nonmetallic conduits and fittings in the electrical industry. Carlton Schedule 40 and Schedule 80 conduits are designed for use aboveground and underground as described in the National Electrical Code. Specify only Carlton conduits and fittings to insure raceway system integrity.

Features

Ease of Installation Nonmetallic conduits are 1/4 to 1/5 the weight of metallic systems, can be installed in less than half the time, and are easily fabricated on the job.

Safety Nonmetallic conduits are nonconductive, assuring a safe system.

Impact Resistant Carlton Schedule 40 and Schedule 80 nonmetallic conduits are resistant to sunlight and are listed for exposed or outdoor usage. The use of expansion fittings allows the system to expand and contract with temperature variations.

Corrosion Resistant Carlton conduits and fittings are nonmetallic and will not rust or corrode.

Carlton nonmetallic Schedule 40 and Schedule 80 conduits and elbows are manufactured to NEMA TC-2, Federal specification WC1094A and UL 651 specifications. Fittings are manufactured to NEMA TC-3, Federal specification WC1094A and UL514B. Both conduit and fittings carry respective UL or ETL Listings and UL or ETL labels.

Schedule 40 PVC Rigid Nonmetallic Conduit (RNC). (Heavy Wall EPC)

Listed for underground applications encased in concrete or direct burial. Also for use in exposed or concealed applications aboveground.

- Sunlight resistant • Rated for use with 90°C conductors • Superior weathering characteristics



RUS Listed

Schedule 40 Heavy Wall

With Integral Bell*



Part No.			Std. Crate Qty.		Wt. Per	Dimensions		
10'	20'	Nom. Size	10'	20'	100'	O.D.	I.D.	Wall
49005-010		1/2"	6000'		17	.840	.622	.109
49007-010	49007-020	3/4"	4400'	8800'	23	1.050	.824	.113
49008-010	49008-020	1"	3600'	7200'	34	1.315	1.049	.133
49009-010	49009-020	1 1/4"	3300'	6600'	46	1.660	1.380	.140
49010-010	49010-020	1 1/2"	2250'	4500'	55	1.900	1.610	.145
49011-010	49011-020	2"	1400'	2800'	73	2.375	2.067	.154
49012-010	49012-020	2 1/2"	930'	1860'	124	2.875	2.469	.203
49013-010	49013-020	3"	880'	1760'	163	3.500	3.068	.216
49014-010	49014-020	3 1/2"	630'	1260'	196	4.000	3.548	.226
49015-010	49015-020	4"	570'	1140'	232	4.500	4.026	.237
49016-010	49016-020	5"	380'	760'	315	5.563	5.047	.258
49017-010	49017-020	6"	260'	520'	409	6.625	6.065	.280

Rigid nonmetallic conduit is normally supplied in standard 10' lengths, with one belled end per length. For specific requirements, it may be produced in lengths shorter or longer than 10', with or without belled ends.

Use RNC Fittings with Schedule 40 and Schedule 80 Conduit.

- Notes: 1. Special fittings and conduit sizes will be quoted on request.
2. DON'T FORGET TO ORDER CEMENT.
3. Carlton reserves the right to ship to the nearest unitized quantity.

Rigid Nonmetallic Conduit – Schedule 80

Schedule 80 PVC Rigid Nonmetallic Conduit (RNC) (Extra Heavy Wall EPC-80)



ETL Listed
to UL 651 in
compliance
to the NEC

LISTED
E35297

Listed for use in aboveground and belowground applications that are subject to physical damage.
• Sunlight resistant • Rated for use with 90°C conductors • Superior weathering characteristics
• For use in areas subject to physical damage

RUS Listed

With Integral Bell*



Schedule 80 Extra Heavy Wall

Part No. 10'	20'	Nom. Size	Std. Crate Qty. Wt. Per			Dimensions		Wall
			10'	20'	100'	O.D.	I.D.	
49405-010	49405-020	1/2"	6000'	12000'	21	.840	.546	.147
49407-010	49407-020	3/4"	4400'	8000'	30	1.050	.742	.154
49408-010	49408-020	1"	3600'	7200'	44	1.315	.957	.179
49409-010	49409-020	1 1/4"	3300'	6600'	60	1.660	1.278	.191
49410-010	49410-020	1 1/2"	2250'	3600'	72	1.900	1.500	.200
49411-010	49411-020	2"	1400'	2800'	101	2.375	1.939	.218
49412-010	49412-020	2 1/2"	930'	1880'	154	2.875	2.323	.276
49413-010	49413-020	3"	880'	1760'	210	3.500	2.900	.300
49415-010	49415-020	4"	570'	1140'	308	4.500	3.826	.337
49416-010	-	5"	380'	-	428	5.563	4.813	.375
49417-010	49417-020	6"	260'	520'	588	6.625	5.761	.432

Rigid nonmetallic conduit is normally supplied in standard 10' lengths, with one belled end per length. For specific requirements, it may be produced in lengths shorter or longer than 10', with or without belled ends.

Use RNC Fittings with Schedule 40 and Schedule 80 Conduit.

Notes: 1. Special fittings and conduit sizes will be quoted on request.
2. DON'T FORGET TO ORDER CEMENT.
3. Carlon reserves the right to ship to the nearest unitized quantity.

Support of Carlon Rigid Nonmetallic Conduit in Aboveground Installations

Table 352.30(B) NEC shows the support requirements for Schedule 40 and Schedule 80 rigid PVC nonmetallic conduit.

Plastic conduit should always be installed away from steam lines, etc. Support straps should allow for lineal movement caused by expansion and contraction.

Maximum ambient temperature is 122°F (50°C).

Table 352.30(B), NEC

Trade Size	Maximum Spacing Between Supports (feet)
1/2 - 1	3
1 1/4 - 2	5
2 1/2 - 3	6
3 1/2 - 5	7
6	8

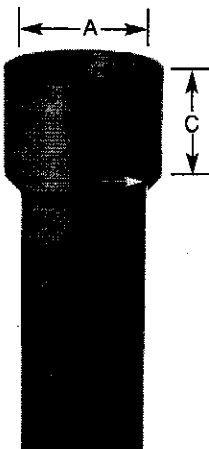

Acceptable Dimensions in Inches of Integral Bell per UL 651

Trade Size	A		B		C
	At Entrance (in.) Maximum	Minimum	At Bottom (in.) Maximum	Minimum	
1/2	0.860	0.844	0.844	0.828	1.375
3/4	1.074	1.054	1.056	1.036	1.500
1	1.340	1.320	1.320	1.300	1.750
1 1/4	1.689	1.665	1.667	1.643	1.875
1 1/2	1.930	1.906	1.906	1.882	2.750
2	2.405	2.381	2.381	2.357	3.250
2 1/2	2.905	2.875	2.883	2.853	3.250
3	3.530	3.500	3.507	3.477	3.875
3 1/2	4.065	3.965	4.007	3.977	3.875
4	4.565	4.465	4.506	4.476	4.625
5	5.643	5.543	5.583	5.523	5.625
6	6.708	6.608	6.644	6.584	6.375

Rigid Nonmetallic Conduit – Schedule 40 Elbows

Schedule 40 Elbows Standard Radius

Available in plain and integral belled end for use with nonmetallic solvent weld fittings.



ETL Listed
to UL 651 in
compliance to
the NEC

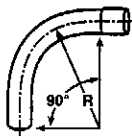
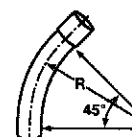
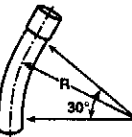

LISTED
E35297

Item	Plain End Part No.	Belled End Part No.	Size	Plain End Std. Ctn. Qty.	Belled End Std. Ctn. Qty.	
90° Elbow 	UA9AD	UA9ADB	1/2"	50	50	
	UA9ADR-CAR	UA9ADB	1/2"	25	50	
	UA9AE	UA9AEB	3/4"	25	25	
	UA9AFR-CTN	UA9AFB-CTN	1"	25	25	
	UA9AG	UA9AGB	1 1/4"	20	20	
	UA9AH	UA9AHB	1 1/2"	25	25	
	UA9AJ	UA9AJB	2"	20	20	
	UA9AJ-CAR	UA9AJB	2"	5	20	
	UA9AK-CAR	UA9AKB-CAR	2 1/2"	10	10	
	UA9AL	UA9ALB-CAR	3"	1	5	
	UA9AM	UA9AMB	3 1/2"	1	20	
	UA9AN	UA9ANB	4"	1	1	
	UA9AP	UA9APB	5"	1	1	
	UA9AR	UA9ARB	6"	1	1	
	45° Elbow 	UA7AD	UA7ADB	1/2"	50	50
		UA7AE	UA7AEB	3/4"	25	25
		UA7AER-CAR	UA7AEB	3/4"	15	25
UA7AF		UA7AFB	1"	20	20	
UA7AF-CAR		UA7AFB	1"	15	20	
UA7AG		UA7AGB	1 1/4"	20	20	
UA7AH		UA7AHB	1 1/2"	20	20	
UA7AJ		UA7AJB	2"	20	20	
UA7AJ-CAR		UA7AJB-CAR	2"	4	4	
UA7AK		UA7AKB	2 1/2"	20	20	
UA7AK-CAR		UA7AKB-CAR	2 1/2"	5	5	
UA7AL-CAR		UA7ALB	3"	5	25	
UA7AL-CAR		UA7ALB-CAR	3"	5	10	
UA7AM		UA7AMB	3 1/2"	1	20	
UA7AN		UA7ANB	4"	1	20	
UA7AP		UA7APB	5"	1	1	
UA7AR		UA7ARB	6"	1	1	
30° Elbow 	UA6AD	UA6ADB	1/2"	50	50	
	UA6AE	UA6AEB	3/4"	25	25	
	UA6AF	UA6AFB	1"	25	1	
	UA6AG	UA6AGB	1 1/4"	20	20	
	UA6AH	UA6AHB	1 1/2"	25	1	
	UA6AJ	UA6AJB	2"	20	20	
	UA6AK	UA6AKB	2 1/2"	10	20	
	UA6AL	UA6ALB	3"	1	1	
	UA6AM	UA6AMB	3 1/2"	1	1	
	UA6AN	UA6ANB	4"	1	1	
	UA6AP	UA6APB	5"	1	1	
	UA6AR	UA6ARB	6"	1	1	

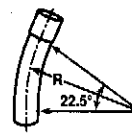
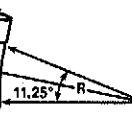
Item	Plain End Part No.	Belled End Part No.	Size	Plain End Std. Ctn. Qty.	Belled End Std. Ctn. Qty.	
22 1/2° Elbow 	UA5AD	-	1/2"	1	-	
	UA5AE	-	3/4"	1	-	
	UA5AF	-	1"	1	-	
	UA5AG	-	1 1/4"	1	-	
	UA5AH	-	1 1/2"	1	-	
	UA5AJ	UA5AJB	2"	25	1	
	UA5AK	-	2 1/2"	20	-	
	UA5AL	UA5ALB	3"	5	1	
	UA5AM	-	3 1/2"	1	-	
	UA5AN	UA5ANB	4"	1	1	
	UA5AP	UA5APB	5"	1	1	
	UA5AR	UA5ARB	6"	1	1	
	11 1/4° Elbow 	UA3AD	-	1/2"	1	-
		UA3AE	-	3/4"	1	-
UA3AF		-	1"	1	-	
UA3AG		-	1 1/4"	1	-	
UA3AH		-	1 1/2"	1	-	
UA3AJ		-	2"	1	-	
UA3AK		-	2 1/2"	1	-	
UA3AL		-	3"	1	-	
UA3AM		-	3 1/2"	1	-	
UA3AN		UA3ANB	4"	1	1	
UA3AP	-	5"	1	-		
UA3AR	-	6"	1	-		

Standard Radius Elbow Dimensions

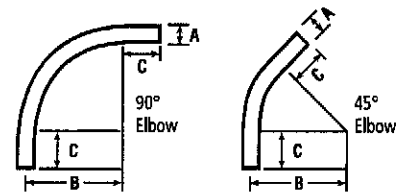

Integral Belled End Dimensions

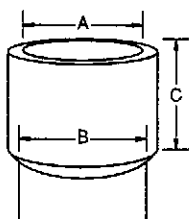

Trade Size	A		B		C	
	At Entrance Max.	Min.	At Bottom Max.	Min.	Socket Depth Max.	Min.
1/2"	.860	0.844	0.844	0.828	1.500	0.652
3/4"	1.074	1.054	1.056	1.036	1.500	0.719
1"	1.340	1.320	1.320	1.300	1.875	0.875
1 1/4"	1.689	1.665	1.667	1.643	2.000	0.938
1 1/2"	1.930	1.906	1.906	1.882	2.000	1.062
2"	2.405	2.381	2.381	2.357	2.000	1.125
2 1/2"	2.905	2.875	2.883	2.853	3.000	1.469
3"	3.530	3.500	3.507	3.477	3.125	1.594
3 1/2"	4.065	3.965	4.007	3.977	3.250	1.687
4"	4.565	4.465	4.506	4.476	3.375	1.750
5"	5.643	5.543	5.583	5.523	3.625	1.937
6"	6.708	6.608	6.644	6.584	3.750	2.125

Size	A	B (Min. Radius)	C (Min.)
1/2"	.840	4"	1 1/2"
3/4"	1.050	4 1/2"	1 1/2"
1"	1.315	5 3/4"	1 7/8"
1 1/4"	1.660	7 1/4"	2"
1 1/2"	1.900	8 1/4"	2"
2"	2.375	9 1/2"	2"
2 1/2"	2.875	10 1/2"	3"
3"	3.500	13"	3 1/8"
3 1/2"	4.000	15"	3 1/4"
4"	4.500	16"	3 3/8"
5"	5.563	24"	3 5/8"
6"	6.625	30"	3 3/4"

Rigid Nonmetallic Conduit – Schedule 40 Elbows

Schedule 40 Elbows Special Radius

*Consult factory for additional sizes/configurations



ETL Listed to UL 651 in compliance to the NEC

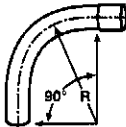

LISTED E35297

Segment	Plain End Part No.	Belled End Part No.	Nom. Diam.	Radius (in.)	Plain End Std. Ctn. Qty.	Belled End Std. Ctn. Qty.
90° Elbow 	UA9CF	UA9CFB	1"	18"	1	1
	UA9DF	UA9DFB	1"	24"	1	1
	UA9EF	UA9EFB	1"	30"	1	1
	UA9FF	-	1"	36"	1	-
	UA9HF	-	1"	48"	1	-
	UA9CG	UA9CGB	1 1/4"	18"	1	1
	UA9DG	UA9DGB	1 1/4"	24"	1	1
	UA9EG	UA9EGB	1 1/4"	30"	1	1
	UA9FG	UA9FGB	1 1/4"	36"	1	1
	UA9HG	-	1 1/4"	48"	1	-
	UA9CH	UA9CHB	1 1/2"	18"	1	1
	UA9DH	UA9DHB	1 1/2"	24"	1	1
	UA9EH	UA9EHB	1 1/2"	30"	1	1
	UA9FH	UA9FHB	1 1/2"	36"	1	1
	UA9HH	-	1 1/2"	48"	1	-
	UA9CJ	UA9CJB	2"	18"	1	1
	UA9DJ	UA9DJB-UPC	2"	24"	1	1
	UA9EJ	UA9EJB	2"	30"	1	1
	UA9FJ-UPC	UA9FJB	2"	36"	1	1
	UA9HJ	UA9HJB	2"	48"	1	1
	UA9JJ	-	2"	72"	1	-
	UA9CK	UA9CKB	2 1/2"	18"	1	1
	UA9DK	UA9DKB-UPC	2 1/2"	24"	1	1
	UA9EK	UA9EKB	2 1/2"	30"	1	1
	UA9FK-UPC	UA9FKB	2 1/2"	36"	1	1
	UA9HK	UA9HKB	2 1/2"	48"	1	1
	UA9CL	UA9CLB	3"	18"	1	1
	UA9DL	UA9DLB-UPC	3"	24"	1	1
	UA9EL	UA9ELB	3"	30"	1	1
	UA9FL	UA9FLB	3"	36"	1	1
	UA9HL	UA9HLB	3"	48"	1	1
	UA9IL	-	3"	60"	1	-
	UA9DM	UA9DMB	3 1/2"	24"	1	1
	UA9EM	UA9EMB	3 1/2"	30"	1	1
	UA9FM	UA9FMB	3 1/2"	36"	1	1
	UA9HM	UA9HMB	3 1/2"	48"	1	1
	-	UA9CNB	4"	18"	-	1
	UA9DN	UA9DNB	4"	24"	1	1
	UA9EN	UA9ENB	4"	30"	1	1
	UA9FN	UA9FNB	4"	36"	1	1
	UA9HN	UA9HNB	4"	48"	1	1
	UA9IN	UA9INB	4"	60"	1	1
	UA9JN	-	4"	72"	1	1
	UA9EP	UA9EPB	5"	30"	1	1
	UA9FP	UA9FPB	5"	36"	1	1
UA9HP	UA9HPB	5"	48"	1	1	
UA9IP	UA9IPB	5"	60"	1	1	
UA9FR	UA9FRB	6"	36"	1	1	
UA9HR	UA9HRB	6"	48"	1	1	
UA9IR	UA9IRB	6"	60"	1	1	
-	UA9TRB	6"	180"	-	1	
UA9HT	-	8"	48"	1	1	

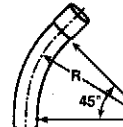
Segment	Plain End Part No.	Belled End Part No.	Nom. Diam.	Radius (in.)	Plain End Std. Ctn. Qty.	Belled End Std. Ctn. Qty.
45° Elbow 	UA7CF	-	1"	18"	1	-
	UA7DF	-	1"	24"	1	-
	UA7EF	-	1"	30"	1	-
	UA7FF	-	1"	36"	1	-
	UA7HF	-	1"	48"	1	-
	UA7CG	-	1 1/4"	18"	1	-
	UA7DG	-	1 1/4"	24"	1	-
	UA7EG	-	1 1/4"	30"	1	-
	UA7FG	-	1 1/4"	36"	1	-
	UA7HG	-	1 1/4"	48"	1	-
	UA7CH	-	1 1/2"	18"	1	-
	UA7DH	-	1 1/2"	24"	1	-
	UA7EH	-	1 1/2"	30"	1	-
	UA7FH	UA7FHB	1 1/2"	36"	1	1
	UA7HH	-	1 1/2"	48"	1	-
	-	UA7BJB	2"	12"	-	1
	UA7CJ	UA7CJB	2"	18"	1	1
	UA7DJ	UA7DJB	2"	24"	1	1
	UA7EJ	UA7EJB	2"	30"	1	1
	UA7FJ	UA7FJB	2"	36"	1	1
	UA7HJ	UA7HJB	2"	48"	1	1
	UA7SJ	-	2"	150"	1	-
	UA7CK	-	2 1/2"	18"	1	-
	UA7DK	UA7DKB	2 1/2"	24"	1	1
	UA7EK	-	2 1/2"	30"	1	-
	UA7FK	UA7FKB	2 1/2"	36"	1	1
	UA7HK	-	2 1/2"	48"	1	-
	UA7CL	UA7CLB	3"	18"	1	1
	UA7DL	UA7DLB	3"	24"	1	1
	UA7EL	UA7ELB	3"	30"	1	1
	UA7FL	UA7FLB	3"	36"	1	1
	-	UA7HLB	3"	48"	-	1
	UA7DM	-	3 1/2"	24"	1	-
	UA7EM	-	3 1/2"	30"	1	-
	UA7FM	-	3 1/2"	36"	1	-
	UA7DN	UA7DNB	4"	24"	1	1
	UA7EN	UA7ENB	4"	30"	1	1
	UA7FN	UA7FNB	4"	36"	1	1
	-	UA7NNB	4"	120"	-	1
	UA7SN	UA7SNB	4"	150"	1	-
	UA7EP	UA7EPB	5"	30"	1	1
	UA7FP	UA7FPB	5"	36"	1	1
	UA7HP	UA7HPB	5"	48"	1	1
	-	UA7IPB	5"	60"	-	1
	-	UA7NPB	5"	120"	-	1
-	UA7SPB	5"	150"	-	1	
UA7FR	UA7FRB	6"	36"	1	1	
UA7HR	UA7HRB	6"	48"	1	1	
UA7FT	-	8"	36"	1	-	
UA7HT	-	8"	48"	1	-	

Rigid Nonmetallic Conduit – Schedule 40 Elbows



ETL Listed to UL 651 in compliance to the NEC



LISTED E35297

Schedule 40 Elbows Special Radius

*Consult factory for additional sizes/configurations

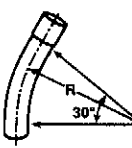
Segment	Plain End Part No.	Belled End Part No.	Nom. Diam.	Radius (in.)	Plain End Std. Ctn. Qty.	Belled End Std. Ctn. Qty.
30° Elbow 	UA6CJ	-	2"	18"	1	-
	UA6DJ	UA6DJB	2"	24"	1	1
	UA6FJ	UA6FJB	2"	36"	1	1
	UA6HJ	UA6HJB	2"	48"	1	1
	UA6CK	-	2 1/2"	18"	1	-
	UA6DK	-	2 1/2"	24"	1	-
	UA6CL	-	3"	18"	1	-
	UA6DL	UA6DLB	3"	24"	1	1
	UA6FL	UA6FLB	3"	36"	1	1
	UA6HL	UA6HLB	3"	48"	1	1
	UA6DM	-	3 1/2"	24"	1	-
	UA6FM	-	3 1/2"	36"	1	-
	UA6HM	-	3 1/2"	48"	1	-
	UA6DN	-	4"	24"	1	-
	UA6FN	UA6FNB	4"	36"	1	1
	UA6HN	UA6HNB	4"	48"	1	1
	UA6FP	UA6FPB	5"	36"	1	1
	UA6HP	UA6HPB	5"	48"	1	1
	UA6FR	UA6FRB	6"	36"	1	1
	UA6HR	UA6HRB	6"	48"	1	1

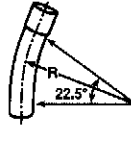

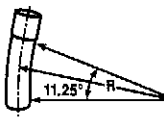
Segment	Plain End Part No.	Belled End Part No.	Nom. Diam.	Radius (in.)	Plain End Std. Ctn. Qty.	Belled End Std. Ctn. Qty.
22 1/2° Elbow 	UA5FF	-	1"	36"	1	-
	UA5FG	-	1 1/4"	36"	1	-
	UA5FH	UA5FHB	1 1/2"	36"	1	1
	UA5CJ	UA5CJB	2"	18"	1	1
	UA5DJ	UA5DJB	2"	24"	1	25
	UA5EJ	UA5EJB	2"	30"	1	1
	UA5FJ	UA5FJB	2"	36"	1	1
	UA5HJ	-	2"	48"	1	-
	UA5VJ	-	2"	300"	1	-
	UA5CK	-	2 1/2"	18"	1	-
	UA5DK	-	2 1/2"	24"	1	-
	UA5EK	-	2 1/2"	30"	1	-
	UA5FK	-	2 1/2"	36"	1	-
	UA5HK	-	2 1/2"	48"	1	-
	-	UA5CLB	3"	18"	1	1
	UA5DL	UA5DLB	3"	24"	1	1
	UA5EL	UA5ELB	3"	30"	1	1
	UA5FL	UA5FLB	3"	36"	1	1
	UA5HL	-	3"	48"	1	-
	UA5VL	-	3"	300"	1	-
	UA5DM	-	3 1/2"	24"	1	-
	UA5EM	-	3 1/2"	30"	1	-
	UA5FM	-	3 1/2"	36"	1	-
	UA5HM	-	3 1/2"	48"	1	-
	UA5DN	UA5DNB	4"	24"	1	1
	UA5EN	UA5ENB	4"	30"	1	1
	UA5FN	UA5FNB	4"	36"	1	1
	UA5HN	UA5HNB	4"	48"	1	-
	UA5IN	-	4"	60"	1	-
	UA5JN	-	4"	72"	1	-
	UA5SN	UA5SNB	4"	150"	1	-
	-	UA5UNB	4"	240"	-	1
	-	UA5VNB	4"	300"	-	1
	-	UA5DPB	5"	24"	1	1
	UA5EP	UA5EPB	5"	30"	1	1
	UA5FP	UA5FPB	5"	36"	1	1
	UA5HP	UA5HPB	5"	48"	1	1
	UA5IP	-	5"	60"	1	-
	UA5SP	-	5"	150"	1	-
	-	UA5UPB	5"	240"	-	1
	-	UA5VPB	5"	300"	-	1
	UA5FR	UA5FRB	6"	36"	1	1
UA5HR	UA5HRB	6"	48"	1	1	
UA5IR	-	6"	60"	1	-	
UA5RR	-	6"	144"	1	-	
UA5SR	-	6"	150"	1	-	
UA5VR	-	6"	300"	1	-	
UA5FT	-	8"	36"	1	-	
UA5HT	-	8"	48"	1	-	

Segment	Plain End Part No.	Belled End Part No.	Nom. Diam.	Radius (in.)	Plain End Std. Ctn. Qty.	Belled End Std. Ctn. Qty.
11 1/4° Elbow 	UA3DJ	UA3DJB	2"	24"	1	25
	UA3FJ	UA3FJB	2"	36"	1	1
	UA3HJ	-	2"	48"	1	-
	UA3HK	-	2 1/2"	48"	1	-
	UA3DL	UA3DLB	3"	24"	1	1
	UA3FL	UA3FLB	3"	36"	1	1
	UA3HL	-	3"	48"	1	-
	UA3DM	-	3 1/2"	24"	1	-
	UA3HM	-	3 1/2"	48"	1	-
	UA3DN	UA3DNB	4"	24"	1	1
	UA3FN	UA3FNB	4"	36"	1	1
	-	UA3SNB	4"	150"	-	1
	UA3HN	UA3HNB	4"	48"	1	1
	UA3FP	UA3FPB	5"	36"	1	1
	UA3HP	-	5"	48"	1	-
	-	UA3UPB	5"	240"	-	1
	UA3FR	UA3FRB	6"	36"	1	1
	UA3HR	-	6"	48"	1	-
	UA3FT	-	8"	36"	1	-

Rigid Nonmetallic Conduit – Schedule 80 Elbows

Schedule 80 Elbows Standard Radius

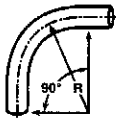
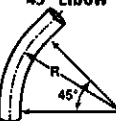
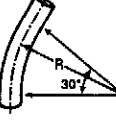
Available in plain end only for use with nonmetallic solvent weld fittings.

Item	Plain End Part No.	Belled End Part No.	Size	Plain End Std. Ctn. Qty.	Belled End Std. Ctn. Qty.
90° Elbow					
	UB9AD	—	1/2"	50	—
	UB9AD-CAR	—	1/2"	25	—
	UB9AE	—	3/4"	25	—
	UB9AE-CAR	—	3/4"	15	—
	UB9AF	—	1"	25	—
	UB9AF-CAR	—	1"	10	—
	UB9AG	—	1 1/4"	20	—
	UB9AG-CAR	—	1 1/4"	5	—
	UB9AH	—	1 1/2"	25	—
	UB9AH-CAR	—	1 1/2"	5	—
	UB9AJ	—	2"	20	—
	UB9AJ-CAR	—	2"	5	—
	UB9AK-CAR	—	2 1/2"	10	—
	UB9AL-CAR	—	3"	5	—
	UB9AN	—	4"	1	—
	UB9AP	UB9APB	5"	1	1
	UB9AR	—	6"	1	—
45° Elbow					
	UB7AD	—	1/2"	50	—
	UB7AE-UPC	—	3/4"	25	—
	UB7AF-UPC	—	1"	20	—
	UB7AG	—	1 1/4"	20	—
	UB7AH	—	1 1/2"	20	—
	UB7AH-CAR	—	1 1/2"	5	—
	UB7AJ-UPC	—	2"	20	—
	UB7AK	—	2 1/2"	20	—
	UB7AL	—	3"	1	—
	UB7AN	—	4"	1	—
	UB7AP	UB7APB	5"	1	1
	UB7AR	—	6"	1	—
30° Elbow					
	UB6AD	—	1/2"	50	—
	UB6AE	—	3/4"	25	—
	UB6AF	—	1"	25	—
	UB6AG	—	1 1/4"	5	—
	UB6AH	—	1 1/2"	25	—
	UB6AJ	—	2"	20	—
	UB6AK	—	2 1/2"	1	—
	UB6AL	—	3"	1	—
	UB6AN	—	4"	1	—
	UB6AP	—	5"	1	—
	UB6AR	—	6"	1	—
22 1/2° Elbow					
	UB5AL	—	3"	5	—
	UB5AN	—	4"	1	—
	UB5AP	UB5APB	5"	1	1
11 1/4° Elbow					
	UB3AL	—	3"	1	—
	UB3AR	—	6"	1	—

Flexible PVC Elbows



- UL listed for exposed and direct burial applications in accordance with Article 356 of 2002 NEC
- 0° - 90° bending and offset applications
- O-ring seal for moisture tight connections
- Maintains round shape throughout bend
- Sunlight resistant
- Non-corrosive – all PVC and Neoprene material
- Fully assembled and ready to use

Part No.	Size	Std. Ctn. Qty.	Std. Ctn. Wt. (lbs.)	Length Fully Assembled
UAFAAD	1/2"	8	1.6	8.5"
UAFAE	3/4"	6	1.9	9.6"
UAFAF	1"	6	2.4	11.9"

Special Radius



ETL Listed to UL 651 in compliance to the NEC

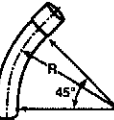
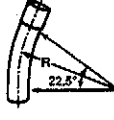

LISTED E35297

Segment	Plain End Part No.	Belled End Part No.	Nom. Diam.	Radius (in.)	Plain End Std. Ctn. Qty.	Belled End Std. Ctn. Qty.
90° Elbow						
	UB9CF	—	1"	18"	1	—
	UB9DF	—	1"	24"	1	—
	UB9FF	—	1"	36"	1	—
	UB9HF	—	1"	48"	1	—
	UB9CG	—	1 1/4"	18"	1	—
	UB9DG	—	1 1/4"	24"	1	—
	UB9FG	—	1 1/4"	36"	1	—
	UB9HG	—	1 1/4"	48"	1	—
	UB9CH	—	1 1/2"	18"	1	—
	UB9DH-UPC	UB9DHB	1 1/2"	24"	1	1
	UB9FH	—	1 1/2"	36"	1	—
	UB9HH	—	1 1/2"	48"	1	—
	UB9CI	—	2"	18"	1	—
	UB9D-UPC	UB9DJB	2"	24"	1	1
	UB9FI	UB9FJB	2"	36"	1	1
	UB9HJ	—	2"	48"	1	—
	UB9CK	—	2 1/2"	18"	1	—
	UB9DK-UPC	UB9DKB	2 1/2"	24"	1	1
	UB9FK	UB9FKB	2 1/2"	36"	1	1
	UB9HK	—	2 1/2"	48"	1	—
	UB9CL	—	3"	18"	1	—
	UB9DL	UB9DLB	3"	24"	1	1
	UB9FL	UB9FLB	3"	36"	1	1
	UB9HL	—	3"	48"	1	—
	UB9DN	UB9DNB	4"	24"	1	1
	UB9FN	UB9FNB	4"	36"	1	1
	UB9HN	UB9HNB	4"	48"	1	—
	UB9NN	—	4"	120"	1	—
	UB9FP	—	5"	36"	1	—
	UB9HP	—	5"	48"	1	—
	UB9IP	—	5"	60"	1	—
	UB9FR	—	6"	36"	1	—
	UB9HR	—	6"	48"	1	—
	UB9IR	—	6"	60"	1	—
45° Elbow						
	UB7CE	—	1"	18"	1	—
	UB7DF	—	1"	24"	1	—
	UB7FF	—	1"	36"	1	—
	UB7HF	—	1"	48"	1	—
	UB7DG	—	1 1/4"	24"	1	—
	UB7FG	—	1 1/4"	36"	1	—
	UB7HG	—	1 1/4"	48"	1	—
	UB7CH	—	1 1/2"	18"	1	—
	UB7DH	UB7DHB	1 1/2"	24"	1	1
	UB7FH	—	1 1/2"	36"	1	—
	UB7HH	—	1 1/2"	48"	1	—
	UB7CJ	—	2"	18"	1	—
	UB7DJ	UB7DJB	2"	24"	1	1
	UB7FJ	UB7FJB	2"	36"	1	1
	UB7HJ	—	2"	48"	1	—
	UB7DK	UB7DKB	2 1/2"	24"	1	1
	UB7FK	—	2 1/2"	36"	1	—
	UB7HK	—	2 1/2"	48"	1	—
	UB7CL	—	3"	18"	1	—
	UB7DL	UB7DLB	3"	24"	1	1
	UB7FL	UB7FLB	3"	36"	1	1
	UB7HL	—	3"	48"	1	—
	UB7DN	UB7DNB	4"	24"	1	1
	UB7FN	UB7FNB	4"	36"	1	1
	UB7HN	—	4"	48"	1	—
	UB7FP	—	5"	36"	1	—
	UB7HP	—	5"	48"	1	—
	UB7FR	—	6"	36"	1	—
	UB7HR	—	6"	48"	1	—
	UB7IR	—	6"	60"	1	—
30° Elbow						
	UB6FN	—	4"	36"	1	—
	UB6FR	—	6"	36"	1	—
22 1/2° Elbow						
	—	UB5DHB	1 1/2"	24"	—	20
	—	UB5DJB	2"	24"	—	20
	—	UB5FJB	2"	36"	—	25
	—	UB5DKB	2 1/2"	24"	—	15
	UB5DL	UB5DLB	3"	24"	1	10
	—	UB5FLB	3"	36"	—	1
	UB5DN	UB5DNB	4"	24"	1	5
	—	UB5FNB	4"	36"	—	1
	UB5FF	—	5"	36"	1	—
11 1/4° Elbow						
	UB3FP	—	5"	36"	1	—

Rigid Nonmetallic Conduit – Couplings

Expansion Fittings

(For Use with Schedule 40 & 80 Conduit)

E945 series expansion fittings are designed to compensate for length changes due to temperature variations in exposed conduit runs.

- EXCLUSIVE Molded in Mid-point indicator on the piston.
- EXCLUSIVE 2" Expansion Fitting with an 8" travel distance.
- Two-piece molded design with lubricated seals for easier movement for the life of the product.
- Ridges on the fitting for easier installation (Sizes 2" through 6" only).
- Male terminal Adapter End design (1/2" – 2" NPT Threads, and 2 1/2" – 6" NPSC Threads).
- Two O-Rings to prevent leakage.
- Can be installed vertically or horizontally.

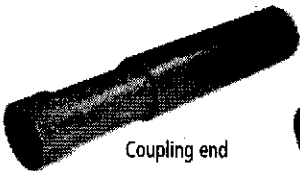

Coupling end



Male terminal adapter end

Coupling End Part No.	Male Terminal Adapter End Part No.	Size	Std. Ctn. Qty.	Travel Length (in.)
E945D	E945DX	1/2	20	4"
E945E	E945EX	3/4	15	4"
E945F	E945FX	1	10	4"
E945G	E945GX	1 1/4	5	4"
E945H	E945HX	1 1/2	5	4"
E945J	E945JX	2	15	8"
E945K	E945KX	2 1/2	10	8"
E945L	E945LX	3	10	8"
E945M	E945MX	3 1/2	5	8"
E945N	E945NX	4	5	8"
E945P	E945PX	5	1	8"
E945R	E945RX	6	1	8"

Short Expansion Couplings

(Expands to a maximum of 2")



Part No.	Size	Std. Ctn. Qty.
E955D	1/2	40
E955E	3/4	40
E955F	1	25
E955G	1 1/4	15
E955H	1 1/2	10
E955J	2	6



Couplings

Standard Couplings



Except where noted by ▶

All socket fittings should be attached using Carlon solvent cement. Using Carlon fittings with Carlon nonmetallic conduit insures system integrity.

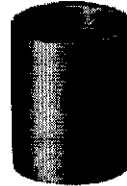

Socket type for joining nonmetallic conduit.

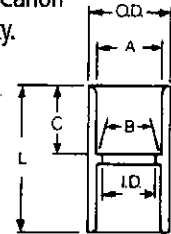

Part No.	Size	Std. Ctn. Qty.	A Typical	B Typical	I.D.	O.D.	C Typical	L Typical
E940D	1/2	150	.852	.836	.728	17/64	11/16	1 1/2
E940E	3/4	100	1.064	1.046	.840	15/16	3/4	1 5/8
E940F	1	50	1.330	1.310	1.210	15/8	15/16	2
E940G	1 1/4	30	1.677	1.655	1.535	1 63/64	1	2 1/8
E940H	1 1/2	25	1.918	1.894	1.755	2 15/64	1 1/8	2 3/8
E940J	2	30	2.393	2.369	2.190	2 47/64	1 3/16	2 1/2
E940K	2 1/2	20	2.890	2.868	2.688	3 5/16	1 33/64	3 1/16
E940K-CAR	2 1/2	4	2.890	2.868	2.688	3 5/16	1 33/64	3 1/16
E940L	3	25	3.515	3.492	3.375	3 31/32	1 3/4	3 13/32
E940L-CAR	3	5	3.515	3.492	3.375	3 31/32	1 3/4	3 13/32
E940M	3 1/2	20	4.015	3.992	3.780	4 9/16	1 3/4	3 5/8
E940N	4	15	4.515	4.491	4.265	5 3/32	1 25/32	3 3/4
E940N-CAR	4	5	4.515	4.491	4.265	5 3/32	1 25/32	3 3/4
E940P	5	8	5.593	5.553	5.097	6 1/4	1 5/16	4 1/16
E940R	6	5	6.658	6.614	6.115	7 1/2	2 3/16	4 5/8

Special Long Line Couplings



Long Line Couplings

Part No.	Size	Std. Ctn. Qty.	Std. Wt. (lbs.)
E941H	1 1/2	40	9
E941J	2	25	8
E941K	2 1/2	15	8
E941L	3	15	14
E941N	4	10	15
E941PF	5	4	12
▶ E941RF	6	5	21

Fabricated Expansion Couplings



Part No.	Size	Std. Ctn. Qty.	Travel Length (in.)
E945KXL	2 1/2	10	12

Rigid Nonmetallic Conduit – Adapters

Couplings

Special Long Line Couplings – Sleeve Couplings



Sleeve Coupling (For Repair Work)
No Internal Stop

Part No.	Size	Std. Ctn. Qty.	Std. Ctn. Wt. (lbs.)
▶ E948H	1 1/2	25	6
▶ E948J	2	25	5
▶ E948K	2 1/2	25	16
▶ E948L	3	25	13
▶ E948N	4	10	8
▶ E948P	5	14	33
▶ E948R	6	6	16
▶ E948JR	2" (6" long)	15	8
▶ E948JS	2" (Sch. 40 Split Duct)	25	6
▶ E948L12	3" (12" long)	1	1
▶ E948L6	3" (6" long)	15	15
▶ E948LS	3" (Sch. 40 Split Duct)	25	17
▶ E948N12	4" (12" long)	10	28
▶ E948N7	4" (7" long)	15	25
▶ E948NS	4" (Sch. 40 Split Duct)	10	15
▶ E948PS	5" (Sch. 40 Split Duct)	1	2
▶ E948R10	6" (10" long)	6	25
▶ E948R12	6" (12" long)	6	25
▶ E948RS	6" (Sch. 40 Split Duct)	1	2

Adapters

Female Adapters

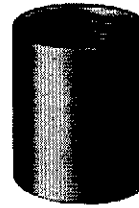

For adapting nonmetallic conduits to threaded fittings, metallic systems. Female threads on one end, socket end on other.



Except where noted by ▶

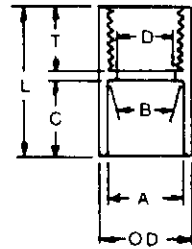

Part No.	Size	Std. Ctn. Qty.	A Typical	B Typical	Min. D	Max. OD	C Typical	T Typical	L Typical
E942D	1/2	150	.852	.836	.620	1 7/64	1 1/16	3/4	1 9/16
E942E	3/4	100	1.064	1.046	.822	1 5/16	1 3/16	3/4	1 5/8
E942F	1	50	1.330	1.310	1.046	1 5/8	1 5/16	7/8	1 15/16
E942G	1 1/4	30	1.677	1.655	1.377	1 63/64	1	7/8	2
E942H	1 1/2	25	1.918	1.894	1.607	2 5/32	1 1/8	7/8	2 7/32
E942J	2	30	2.393	2.369	2.064	2 27/64	1 3/16	1	2 9/16
E942K	2 1/2	20	2.890	2.868	2.450	3 11/32	1 5/8	1 1/8	2 15/16
E942K-CAR	2 1/2	4	2.890	2.868	2.450	3 11/32	1 5/8	1 1/8	2 15/16
E942L	3	25	3.515	3.492	3.000	3 31/32	1 3/4	1 1/8	3 1/16
E942L-CAR	3	3	3.515	3.492	3.000	3 31/32	1 3/4	1 1/8	3 1/16
E942M	3 1/2	20	4.015	3.992	3.500	4 1/2	1 7/8	1 1/8	3 1/4
E942N	4	15	4.515	4.491	4.000	5 1/64	2	1 1/8	3 3/64
E942N-CAR	4	7	4.515	4.491	4.000	5 1/64	2	1 1/8	3 3/64
E942NX9*	4	15	(Call for information)						
E942P	5	8	5.593	5.553	5.047	6 1/4	1 15/16	1 1/16	3 3/16
E942R	6	6	6.658	6.614	6.055	7 1/4	2 1/8	1 1/16	3 3/8
E942RX*	6	6	(Call for information)						

* Long Line Adapter

Special Schedule 40 Swedge Couplings

*Consult factory for additional sizes



Part No.	Size	Std. Ctn. Qty.	Std. Ctn. Wt. (lbs.)
▶ E442K	2 1/2	20	13
▶ E442R	6	6	27
▶ E442T	8	2	17

Male Terminal Adapters



For adapting nonmetallic conduits to boxes, threaded fittings, metallic systems. Male threads on one end, socket end on other.

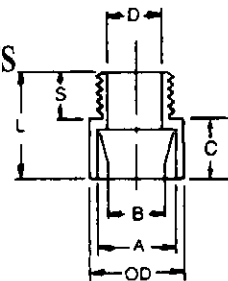

Part No.	Size	Std. Ctn. Qty.	A Typical	B Typical	Min. D	Max. OD	C Typical	S Typical	L Typical
E943D	1/2	150	.852	.836	.597	1 1/8	5/8	9/16	1 5/16
E943E	3/4	125	1.064	1.046	.800	1 11/32	3/4	9/16	1 3/8
E943F	1	50	1.330	1.310	1.018	1 5/8	1	1 1/16	1 25/32
E943G	1 1/4	50	1.677	1.655	1.332	2 1/32	1	3/4	1 15/16
E943H	1 1/2	25	1.918	1.894	1.566	2 5/32	1 3/16	3/4	2 1/16
E943J	2	50	2.393	2.369	2.000	2 21/32	1 3/16	3/4	2 1/8
E943K	2 1/2	25	2.890	2.868	2.376	3 5/16	1 3/4	7/8	2 7/8
E943K-CAR	2 1/2	5	2.890	2.868	2.376	3 5/16	1 3/4	7/8	2 7/8
E943L	3	45	3.515	3.492	2.954	4	1 15/16	7/8	3 1/16
E943L-CAR	3	5	3.515	3.492	2.954	4	1 15/16	7/8	3 1/16
E943M	3 1/2	30	4.015	3.992	3.440	4 1/2	2 7/16	1 7/8	3 7/16
E943N	4	20	4.515	4.491	3.940	5 3/32	2 3/8	7/8	3 1/2
E943N-CAR	4	20	4.515	4.491	3.940	5 3/32	2 3/8	7/8	3 1/2
E943P	5	5	5.593	5.553	4.815	6 1/4	2 1/3	1	3 15/16
E943R	6	10	6.658	6.614	5.860	7 1/2	2 3/8	1	3 3/8

Risers Schedule 40

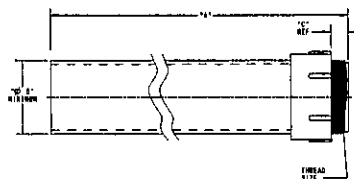

Part No.	Size	A (Length)	B (Min.)	C	Thread Size	Std. Ctn. Qty.	Std. Ctn. Wt. (lbs.)
E954HX	1 1/2	80.00	1.567	.950	1 1/2" NPT	1	3.8
E954J	2	60.00	2.024	.825	2" NPT	1	3.7
E954JX	2	80.00	2.024	.825	2" NPT	1	5.0
E954K	2 1/2	60.00	2.418	.812	2 1/2" NPSC	1	6.0
E954KX	2 1/2	80.00	2.418	.812	2 1/2" NPSC	1	8.4
E954L	3	60.00	3.012	.798	3" NPSC	1	8.7
E954LX	3	80.00	3.012	.798	3" NPSC	1	11.0

Rigid Nonmetallic Conduit – Fittings & Accessories



LISTED

E32447

Except where noted by ▶

Adapters

Box Adapters for Enclosures



Adapts nonmetallic conduit to all electrical enclosures by inserting adapter through knockout and cementing into Carlon couplings.

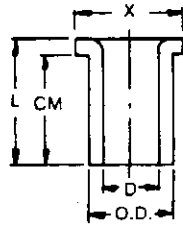

Part No.	Size	Std. Ctn. Qty.	Min D	OD Typical	Max X	CM Typical	L
E996D	1/2	100	.662	.840	17/64	23/32	27/32
E996E	3/4	100	.824	1.050	121/64	25/32	29/32
E996F	1	100	1.049	1.315	15/8	51/64	13/32
E996G	1 1/4	50	1.380	1.660	131/32	11/16	11/4
E996H	1 1/2	50	1.610	1.900	213/64	13/16	13/8
E996J	2	25	2.067	2.375	229/32	11/4	17/16
E996K-CAR	2 1/2	10	2.469	2.875	37/16	17/8	115/16
E996L	3	20	3.068	3.500	41/8	2	2 1/16
E996L-CAR	3	5	3.068	3.500	41/8	2	2 1/16
E996N	4	10	4.026	4.500	51/8	2 1/2	2 1/4

Threaded Adapters

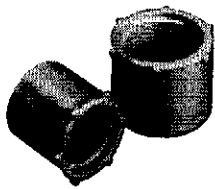

Part No.	Size	Std. Ctn. Qty.
E9842D ¹	1/2	25
E9842E ²	3/4	25

¹ Fits 3/4" sockets ² Fits 1" sockets

Reducers

Reducer Bushings



For connecting different sizes of conduit. Bell x Spigot.

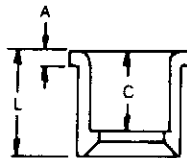

Part No.	Size	Std. Ctn. Qty.	L Typical	A Typical	C Typical
E950ED	3/4" x 1/2"	100	15/32	13/64	11/32
E950FD-CAR	1" x 1/2"	25	111/32	3/16	57/64
E950FE	1" x 3/4"	100	111/32	3/16	11/64
E950GE-CAR	1 1/4" x 3/4"	10	115/32	3/16	11/64
E950GF	1 1/4" x 1"	50	115/32	3/16	19/64
E950HF-CAR	1 1/2" x 1"	10	119/32	3/16	19/64
E950HG-CAR	1 1/2" x 1 1/4"	10	119/32	3/16	117/64
E950JG-CAR	2" x 1 1/4"	10	13/4	7/32	117/64
E950JH-CAR	2" x 1 1/2"	10	13/4	7/32	125/64
E950KJ-CAR	2 1/2" x 2"	10	25/32	3/8	127/64
E950LJ-CAR	3" x 2"	10	21/8	1/4	17/8
▶ E950LK	3" x 2 1/2"	25	115/16	1/4	111/16
E950NL	4" x 3"	25	23/4	5/16	115/16

Reducers

Fabricated Reducers



Fabricated Reducers (Male x Male)

Part No.	Size	Std. Ctn. Qty.	Std. Ctn. Wt. (lbs.)
▶ E952KJ	2 1/2" x 2"	48	28
▶ E952LJ	3" x 2"	36	21
▶ E952LK	3" x 2 1/2"	36	31
▶ E952NL	4" x 3"	15	23
▶ E952NM	4" x 3 1/2"	15	25
▶ E952PN	5" x 4"	12	26
▶ E952RP	6" x 5"	10	31

Plugs

Reducer Plugs



Part No.	Size	Std. Ctn. Qty.	Std. Ctn. Wt. (lbs.)
▶ E971C	3/4" x 1/2"	100	2
▶ E971D	1" x 3/4"	100	3

Plugs (Polyethylene)



Part No.	Size	Std. Ctn. Qty.	Std. Ctn. Wt. (lbs.)
▶ P258H	1 1/2"	50	2
▶ P258K	2 1/2"	25	1.5

Plugs with Pull Tabs (Polyethylene)



Part No.	Size	Std. Ctn. Qty.	Std. Ctn. Wt. (lbs.)
▶ P258JT	2	60	3
▶ P258LT	3	30	3
▶ P258NT	4	48	8
▶ P258PT	5	30	6
▶ P258RT	6	30	9

Rigid Nonmetallic Conduit – Fittings & Accessories



LISTED
E32447

Except where noted by ▶

Caps

Service Entrance Caps



Part No.	Size	Std. Ctn. Qty.	Dimensions (in.)		
			F	G	H
E998D	1/2	5	.45	.45	—
E998E	3/4	20	.45	.45	—
E998E-CAR	3/4	5	.45	.45	—
E998F	1	15	.59	.58	—
E998F-CAR	1	5	.59	.58	—
E998G-CAR	1 1/4	5	.74	.71	.50
E998H-CAR	1 1/2	5	.74	.71	.50
E998J-CAR	2	5	.83	.78	.56
E998K-UPC	2 1/2	2	1.70	1.31	1.00
E998L	3	2	1.70	1.31	1.00
E998N	4	2	2.25	1.88	1.31

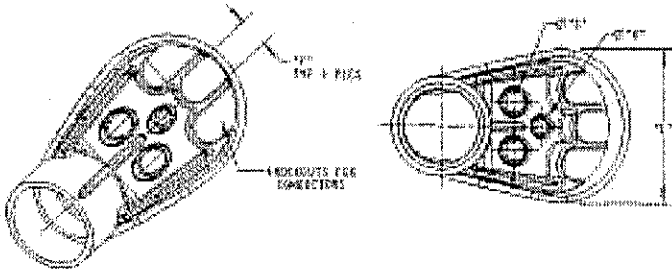

End Caps

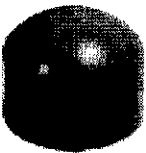

Part No.	Size	Std. Ctn. Qty.	Std. Ctn. Wt. (lbs.)
▶ E958D	1/2	100	3
▶ E958E	3/4	100	4
▶ E958F	1	75	5
▶ E958G	1 1/4	40	4
▶ E958H	1 1/2	30	4
▶ E958J	2	25	5
▶ E958K	2 1/2	10	4
▶ E958L	3	10	5
▶ E958N	4	5	17
▶ E958P	5	5	11
▶ E958R	6	5	13

PVC Riser Caps



Part No.	Size	Std. Ctn. Qty.	Std. Ctn. Wt. (lbs.)
▶ E935J	2	25	9
▶ E935L	3	25	18
▶ E935N	4	25	18
▶ E935P	5	25	35
▶ E935R	6	10	13

Offsets

Meter Offset

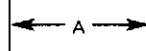

Part No.	Size	Std. Ctn. Qty.	Offset	A
▶ E995G	1 1/4	15	0.758	4.230
E995G-CTN	1 1/4	6	0.758	4.230
▶ E995J	2	8	0.684	4.270

Offset



Part No.	Size	Std. Ctn. Qty.	Std. Ctn. Wt. (lbs.)
▶ E994DR-CAR	1/2	25	3
▶ E994ER-CAR	3/4	15	2
▶ E994F	1	50	12

End Bells

End Bells



Part No.	Size	Std. Ctn. Qty.	Std. Ctn. Wt. (lbs.)
▶ E997F	1	50	1
▶ E997F-CAR	1	15	1
▶ E997G	1 1/4	35	1
▶ E997G-CAR	1 1/4	15	1
▶ E997H	1 1/2	30	1
▶ E997H-CAR	1 1/2	10	1
▶ E997J	2	40	1
▶ E997J-CAR	2	10	1
▶ E997K	2 1/2	30	2
▶ E997K-CAR	2 1/2	10	2
▶ E997L	3	50	2
▶ E997L-CAR	3	10	2
▶ E997M	3 1/2	40	10
▶ E997N	4	30	11
▶ E997P	5	15	10
▶ E997R	6	10	7.4
▶ E997T	8	3	14.55

Fabricated End Bells

Schedule 40



Part No.	Size	Std. Ctn. Qty.	Std. Ctn. Wt. (lbs.)
E949J5	2" x 5"	50	10
E949J6	2" x 6"	25	12
E949JN	2" x 4"	25	7
E949JX	2" x 8"	12	7
E949LR	3" x 6"	20	21
E949N5	4" x 5"	20	2
E949NR	4" x 6"	15	21
E949R5	6" x 5"	12	27
E949RX	6" x 8"	6	17

Rigid Nonmetallic Conduit – Fittings & Accessories

Washers

Flat Sealing Washer

Where a waterproof termination is required into any enclosure (metallic or nonmetallic), install the neoprene washer over the threads of a terminal adapter before inserting into the enclosure. Use a standard locknut or threaded bushing to secure the assembly.

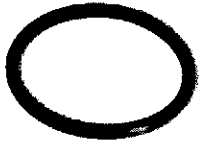

Part No.	Size	Std. Ctn. Qty.
▶ E943DW	1/2	125
▶ E943EW	3/4	125
▶ E943FW	1	100
▶ E943GW	1 1/4	50
▶ E943HW	1 1/2	50
▶ E943JW	2	25

Lock Nuts



PVC Lock Nut



Part No.	Size	Std. Ctn. Qty.
▶ LT9LD	1/2	1200
▶ LT9LE	3/4	700
▶ LT9LF	1	600

Pull Elbows

Access Pull Elbows



Gasket included.

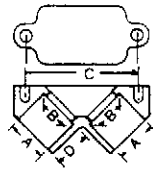

Part No.	Size	Std. Ctn. Qty.	A Typical	B Typical	C Typical	D Typical
E990D	1/2	75	.852	.836	2.187	.718
E990DR-CAR	1/2	25	.852	.836	2.187	.718
E990E	3/4	50	1.064	1.046	2.531	.781
E990ER-CAR	3/4	20	1.064	1.046	2.531	.781

Sleeves

HOLFORM™ Concrete Sleeves

HOLFORM nonmetallic concrete sleeve forms are the easy way to form holes in concrete. They install in seconds with nails, screws or staples and are easily removed. Concrete will not adhere to them. HOLFORMS are adjustable to any slab thickness.



E32447

Except where noted by ▶

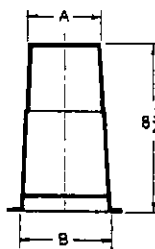

Part No.	Min. O.D. A	B	Std. Ctn. Qty.	Std. Ctn. Wt. (lbs.)
▶ E92CSH	1 1/2	1 3/4	20	3
▶ E92CSJ	2	2 13/32	25	6
▶ E92CSL	3	3 13/32	25	8
▶ E92CSN	4	4 13/32	18	8
▶ E92CSP	5	5 13/32	15	8
▶ E92CSR	6	6 13/32	12	8

Conduit Bodies

Type X with Cover

Four knock-out type socket openings, 90° spacing. Available with 1/2" or 3/4" socket outlets. Includes cover and gasket.

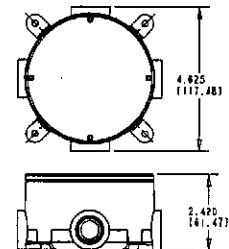
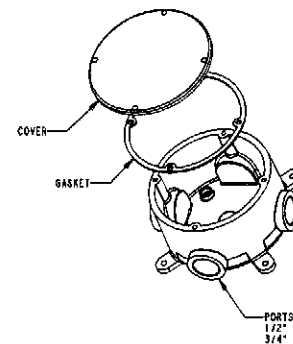
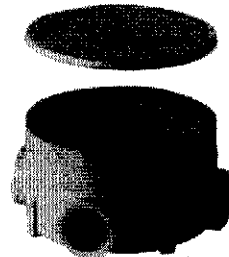

Part No.	Size	Vol. Cu. In.	Std. Ctn. Qty.
E970CD	1/2	15.16	15
E970CE	3/4	15.16	15

Supplied with 4 stainless steel cover screws. Diameter 4 1/8", Thickness 1/4".
*Not designed for use with wiring devices or light fixtures.

Rigid Nonmetallic Conduit – Clamps

Nonmetallic Clamps

Nonmetallic clamps offer the same chemical resistance as Carlon nonmetallic conduits for a complete, corrosion resistant system.

To be used in accordance with conduit spacing requirements per the NEC, Section 352.30.

- UV inhibited for use in direct sunlight

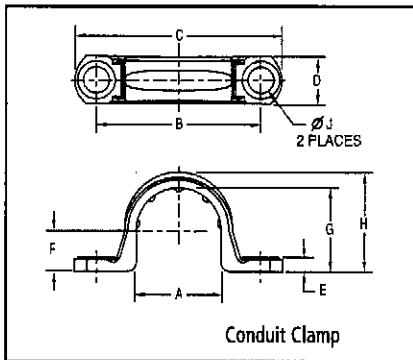
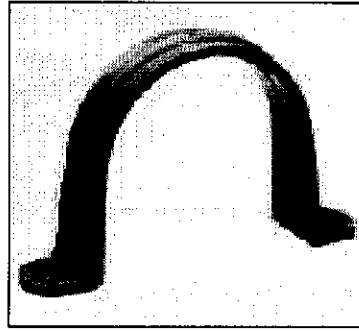

Conduit Clamps

Part No.	Size: inches (mm)	Std. Ctn. Qty.	Std. Ctn. Wt. (lbs.)	A	B	C	D	E	F	G	H	J
E977DC	1/2" (16)	100	1.2	0.892 (22.6)	1.71 (43.4)	2.16 (54.8)	0.50 (12.7)	.14 (3.5)	.42 (10.6)	.866 (21.9)	1.04 (26.4)	.260 (6.6)
E977EC	3/4" (21)	100	1.4	1.102 (27.9)	1.97 (50.0)	2.40 (60.9)	0.50 (12.7)	.14 (3.5)	.525 (13.3)	1.076 (27.3)	1.255 (31.8)	.260 (6.6)
E977FC	1" (27)	100	2	1.39 (35.3)	2.25 (57.1)	2.81 (71.3)	0.594 (15.0)	.14 (3.5)	.658 (16.7)	1.342 (34.0)	1.574 (39.9)	.260 (6.6)
E977GC	1 1/4" (35)	50	5	1.714 (43.5)	2.68 (68.0)	3.28 (83.3)	.64 (16.2)	.15 (3.8)	.83 (21.0)	1.687 (42.8)	1.89 (48.0)	.320 (8.1)
E977HC	1 1/2" (41)	50	6	1.92 (48.7)	2.82 (71.6)	3.44 (87.3)	.70 (17.7)	.15 (3.8)	.97 (24.6)	1.93 (49.0)	2.12 (53.8)	.312 (7.9)
E977JC	2" (53)	25	4.5	2.54 (64.5)	3.54 (89.9)	4.18 (106.1)	.76 (19.3)	.16 (4.0)	1.05 (26.6)	2.29 (58.1)	2.49 (63.2)	.315 (8.0)
E977KC-CAR	2 1/2" (63)	25	1.4	2.86 (72.6)	4.50 (114.3)	5.46 (138.7)	1.00 (25.4)	.20 (5.08)	1.43 (36.3)	2.86 (72.6)	3.12 (79.2)	.36 (9.14)
E977LC-CAR	3" (78)	20	1.4	3.47 (88.2)	5.00 (127.0)	6.00 (152.4)	1.00 (25.4)	.20 (5.08)	1.74 (44.3)	3.48 (88.4)	3.70 (94.0)	.36 (9.14)
E977NC-CAR	4" (103)	15	12.2	4.366 (110.9)	6.15 (156.2)	7.20 (182.9)	1.00 (25.4)	.20 (5.08)	2.32 (58.8)	4.50 (114.3)	4.70 (119.4)	.36 (9.14)

*Note: Some clamp applications require 2 screws, 2 nuts and 2 washers.

Rigid Nonmetallic Conduit – Technical Information

Typical Properties of Conduit Raw Material Compound

Thermal	ASTM Test	Typical Values
Co-efficient of Thermal Expansion-inch/inch/°F (properties @ 73.4°F)	D696	3.38 x 10 ⁻⁵
Heat Distortion °F at 264 psi	D648	160°F
Thermal Conductivity BTU (hr.) (ft.) (°F/in.)	N/A	1.3

Mechanical	ASTM Test	Typical Values
Specific Gravity	D792	1.43 - 1.6
Tensile Strength (psi) @ 73.4°F	D638	5,000-6,500
Izod Impact ft lbs./in. of notch	D256	0.65 - 1.5
Flexural Strength (psi)	D790	12,500
Compressive Strength (psi)	D695	9,000
Hardness (Durometer D)	D2240	85

Electrical	ASTM Test	Typical Values
Dielectrical Strength volts/mil	D149	1100
Dielectric Constant 60 CPS @ 30°C	D150	4.00
Power Factor 60 CPS @ 30°C	D150	1.93

Impedance (Volts lost per ampere per 100 feet)	Trade Size			
	3Ø90% P.F.	80% P.F.	1Ø90% P.F.	80% P.F.
Steel Conduit	.0118	.0123	.0136	.0142
Schedule 40 ^o	.0105	.0106	.0121	.0122

Using 250 KCmil Cu. conductor, comparable values for other conductor sizes.

Wire Fill

Maximum number of conductors in Schedule 40 PVC conduit
(Based on Table 1, Chapter 9 of the NEC)

Type Letters	Conductor Size AWG, MCM	Trade Size															
		1/2	3/4	1	1 1/4	1 1/2	2	2 1/2	3	3 1/2	4	4 1/4	5	6	8		
THWN	14	13	24	39	69	94	154										
	12	10	18	29	51	79	114	164									
	10	6	11	18	32	44	73	194	160								
	8	3	5	9	19	22	36	51	71	106	136						
THHN	6	1	4	6	11	15	26	37	57	76	98	125	154				
	4	1	2	4	7	9	16	22	35	47	60	75	94	137	236		
FEP (14 thru 2)	3	1	1	3	6	8	13	19	29	39	51	64	90	116	201		
FEPB (14 thru 8)	2	1	1	3	5	7	11	16	25	33	43	54	67	97	169		
	1	1	1	3	5	9	12	18	25	32	49	59	72	125			
PFA (14 thru 4/0)	1/0	1	1	3	4	7	10	15	21	27	33	42	61	105			
	2/0	1	1	2	3	6	8	13	17	22	28	35	51	88			
PFAH (14 thru 4/0)	3/0	1	1	1	3	5	7	11	14	18	23	29	42	73			
	4/0	1	1	1	2	4	6	9	12	15	19	24	35	61			
Z (14 thru 4/0)	250			1	1	3	4	7	10	12	16	20	28	49			
	300			1	1	3	4	6	8	11	13	17	24	42			
	350			1	1	2	3	5	7	9	12	15	21	37			
	400			1	1	1	3	5	6	8	10	13	19	33			
XHHW (4 thru 500MCM)	500			1	1	1	2	4	5	7	9	11	16	27			
	600			1	1	1	3	4	5	7	9	13	22				
	700			1	1	1	3	4	5	6	8	11	19				
	750			1	1	1	2	3	4	6	7	11	19				
XHHW	6	1	3	5	9	13	21	30	47	63	81	102	128	185	320		
	600			1	1	1	3	4	5	7	9	13	22				
	700			1	1	1	3	4	5	6	7	11	19				
	750			1	1	1	2	3	4	6	7	10	18				

Maximum number of conductors in Schedule 80 PVC conduit
(Based on Table 1, Chapter 9 of the NEC)

Conductor Size AWG, MCM		Trade Size															
		1/2	3/4	1	1 1/4	1 1/2	2	2 1/2	3	4	5						
#14	THW	4	8	13	24	34	57	82	128								
	THHN	10	19	33	58	81	135	194	0								
12	THW	3	6	11	20	28	47	67	105	183							
	THHN	8	14	24	43	60	100	144	0								
10	THW	3	5	9	16	22	37	54	85	148							
	THHN	5	9	15	27	38	64	92	143								
8	THW	1	2	4	8	11	19	28	44	77	121						
	THHN	1	4	7	13	18	31	45	70	123	195						
6	THW	1	1	3	6	8	14	20	32	56	88						
	THHN	1	3	5	9	13	22	32	50	88	140						
4	THW	0	1	2	4	6	10	15	24	42	66						
	THHN	1	1	3	6	8	13	20	31	54	86						
3	THW	0	1	1	4	5	9	13	20	36	57						
	THHN	1	1	2	5	7	11	17	26	46	73						
2	THW	0	1	1	3	4	8	11	17	31	49						
	THHN	1	1	1	4	5	9	14	22	38	61						
1	THW	0	1	1	1	3	5	8	13	22	35						
	THHN	0	1	1	3	4	7	10	16	28	45						
0	THW	0	0	1	1	2	4	7	11	19	30						
	THHN	0	1	1	2	3	6	8	13	24	38						
00	THW	0	0	1	1	1	4	6	9	16	26						
	THHN	0	1	1	3	5	7	11	20	32	52						
000	THW	0	0	1	1	1	3	5	8	14	22						
	THHN	0	0	1	1	2	4	6	9	16	26						
0000	THW	0	0	1	1	1	3	4	6	11	18						
	THHN	0	0	1	1	1	3	5	8	14	22						
250	THW	0	0	0	1	1	3	5	9	14							
	THHN	0	0	0	1	1	2	4	6	11	18						
300	THW	0	0	0	1	1	3	4	8	13							
	THHN	0	0	0	1	1	1	3	5	9	15						
350	THW	0	0	0	1	1	1	2	4	7	11						
	THHN	0	0	0	1	1	1	3	4	8	13						
400	THW	0	0	0	0	1	1	1	3	6	10						
	THHN	0	0	0	0	1	1	2	4	7	12						
500	THW	0	0	0	0	0	1	1	1	3	5	8					
	THHN	0	0	0	0	1	1	1	3	6	10						
600	THW	0	0	0	0	0	1	1	1	4	7						
	THHN	0	0	0	0	1	1	1	3	5	8						
700	THW	0	0	0	0	0	1	1	1	3	6						

Weight Comparison

Carlson Schedule 40^o rigid nonmetallic conduit compared to other rigid conduit in pounds per 100 feet (approx.)

Nom. Size	Carlson Schedule 40 ^o Rigid Nonmetallic Conduit	Carlson Schedule 80 ^o Rigid Nonmetallic Conduit	Aluminum	Electrical Metallic Tubing (EMT)	Intermediate Metal Conduit (IMC)	Rigid Metal Conduit (RMC)
1/2	18	22	27	30	57	79
3/4	23	29	36	46	78	105
1	35	43	53	66	112	153
1 1/4	48	60	70	96	114	201
1 1/2	57	72	86	112	176	246
2	76	100	116	142	230	334
2 1/2	125	153	183	230	393	527
3	164	212	239	270	483	690
3 1/2	198	288	350	350	561	831
4	234	310	340	400	625	982
5	317	431	465	Not Made	Not Made	1344
6	412	592	612	Not Made	Not Made	1770

Rigid Nonmetallic Conduit – Expansion and Contraction

Expansion and Contraction

Temperature Considerations for Rigid Nonmetallic Conduit Compensation for Linear Expansion

Like all construction materials, PVC will expand or contract with variations in temperatures. The coefficient of linear expansion in PVC conduit is 3.38×10^{-5} in./in./°F as compared to 1.2×10^{-5} for aluminum and 0.6×10^{-5} for steel. An expansion coupling is needed whenever the change in length due to temperature variation will exceed 1/2 in.

Add 30°F to the estimated temperature range when conduit is installed in direct sunlight to allow for radiant heating.

An expansion coupling consists of two sections of conduit, one telescoping inside another. When installing expansion couplings, alignment of piston and barrel is important. Be sure to mount expansion joint level for best performance.

For a vertical run, the expansion coupling must be installed close to the top of the run with the barrel jointing down, in order that rain water does not run into the opening. The lower end of the conduit run must be secured at the bottom so that any length change due to temperature variation will result in an upward movement.

Expansion Characteristics of PVC Rigid Nonmetallic Conduit Coefficient of Thermal Expansion = 3.38×10^{-5} in./in./°F

Temperature Change in Degrees F	Length Change in inches per 100 Ft. of PVC Conduit	Temperature Change in Degrees F	Length Change in inches per 100 Ft. of PVC Conduit	Temperature Change in Degrees F	Length Change in inches per 100 Ft. of PVC Conduit	Temperature Change in Degrees F	Length Change in inches per 100 Ft. of PVC Conduit
5	0.2	55	2.2	105	4.2	155	6.3
10	0.4	60	2.4	110	4.5	160	6.5
15	0.6	65	2.6	115	4.7	165	6.7
20	0.8	70	2.8	120	4.9	170	6.9
25	1.0	75	3.0	125	5.1	175	7.1
30	1.2	80	3.2	130	5.3	180	7.3
35	1.4	85	3.4	135	5.5	185	7.5
40	1.6	90	3.6	140	5.7	190	7.7
45	1.8	95	3.8	145	5.9	195	7.9
50	2.0	100	4.1	150	6.1	200	8.1

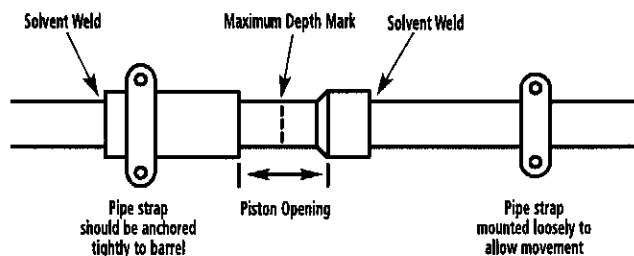

Determine the Piston Opening

The expansion joint must be installed to allow both expansion and contraction of the conduit run. The correct piston opening for any installation condition should use the following formula:

$$O = \left[\frac{T_{\text{max}} - T_{\text{installed}}}{\Delta T} \right] E$$

Where:

- O = Piston opening (in.)
- T max = Maximum anticipated temperature of conduit (°F)
- T inst. = Temperature of conduit at time of installation (°F)
- Δ T = Total change in temperature of conduit (°F)
- E = Expansion allowance built into each expansion coupling (in.)

Example

380 ft. of conduit is to be installed on the outside of a building exposed to the sun in a single straight run. It is expected that the conduit will vary in temperature from 0°F in the winter to 140°F in the summer (this includes the 30°F for radiant heating from the sun.) The installation is to be made at a conduit temperature of 90°F. From the table, a 140°F temperature change will cause a 5.7 in. length change in 100 ft. of conduit. The total change for this example is $5.7 \times 3.8 = 21.67$ " which should be rounded to 22". The number of expansion couplings will be 22" x coupling range (4" for Carlon trade sizes 1/2" through 1-1/2", and 8" for sizes 2" through 6"). If the E945D coupling is used, the number will be $22 \times 4 = 5.50$ which should be rounded to 6. The coupling should be placed at 62 ft. intervals (380×6). the proper piston setting at the time of installation is calculated as explained above.

$$O = \left[\frac{140 - 90}{140} \right] 4.0 = 1.4 \text{ in.}$$

Insert the piston into the barrel to the maximum depth. Place a mark on the piston at the end of the barrel. To properly set the piston, pull the piston out of the barrel to correspond to the 2.1 in. calculated above. See drawing at lower left.

Summary

1. Anticipate expansion and contraction of PVC conduit in aboveground, exposed installation.
2. Use an expansion coupling when length change due to temperature variation will exceed 1/2".
3. PVC conduit expands 4.1" for each 100 feet of run and a 100°F temperature change.
4. Align expansion coupling with the conduit run to prevent binding.
5. Follow the instructions to set the piston opening.
6. Rigidly fix the outer barrel of the expansion coupling so it cannot move. Mount the conduit connected to the piston loosely enough to allow the conduit to move as the temperature changes.

Corrosion Resistance of Carlon Schedule 40 and Schedule 80 PVC Conduit and Fittings

Carlon Schedule 40 and Schedule 80 are generally acceptable for use in environments containing the chemicals below. These environmental resistance ratings are based upon tests where the specimens were placed in complete submergence in the reagent listed. Schedule 40 and Schedule 80 can be used in many process areas where

chemicals not on this list are manufactured or used because worker safety requirements dictate that any air presence or splashing be at a very low level.

If there are any questions for specific suitability in a given environment, prototype samples should be tested under actual conditions.

Acetic Acid 0-20%	Butyl Alcohol	Fluorine Gas – Wet	Mercurous Nitrate	Sodium Arsenite
Acetic Acid 20-30%	Butyl Phenol	Fluorine Gas – Dry	Mercury	Sodium Benzoate
Acetic Acid 30-60%	Butylene	Fluoroboric Acid	Methyl Sulfate	Sodium Bicarbonate
Acetic Acid 80%	Butyric Acid	Fluorosilicic Acid	Methylene Chloride	Sodium Bisulfate
Acetic Acid – Glacial	Calcium Bisulfite	Formaldehyde	Mineral Oils	Sodium Bisulfite
Acetic Acid Vapors	Calcium Carbonate	Formic Acid	Naphthalene	Sodium Bromide
Acetylene	Calcium Chlorate	Fructose	Nickel Chloride	Sodium Chlorate
Adipic Acid	Calcium Chloride	Gallic Acid	Nickel Nitrate	Sodium Chloride
Alum	Calcium Hydroxide	Gas – Coke Oven	Nitric Acid, Anhydrous	Sodium Cyanide
Aluminum Chloride	Calcium Hypochlorite	Gas – Natural (Dry)	Nitric Acid 20%	Sodium Dichromate
Aluminum Fluoride	Calcium Nitrate	Gas – Natural (Wet)	Nitric Acid 40%	Sodium Ferricyanide
Aluminum Hydroxide	Calcium Sulfate	Gasoline – Sour	Nitric Acid 60%	Sodium Ferrocyanide
Aluminum Oxochloride	Carbonic Acid	Gasoline – Refined	Nitrobenzene	Sodium Fluoride
Aluminum Nitrate	Carbon Dioxide Gas – Wet	Glucose	Nitrous Oxide	Sodium Hydroxide
Aluminum Sulfate	Carbon Dioxide – Aqueous Solution	Glycerine (Glycerol)	Oils and Fats	Sodium Hypochlorite
Ammonia-Dry Gas	Carbon Monoxide	Glycol	Oils – Petroleum – (See Type)	Sodium Nitrate
Ammonium Bifluoride	Caustic Potash	Glycolic Acid	Oleic Acid	Sodium Nitrite
Ammonium Carbonate	Caustic Soda	Green Liquor (Paper Industry)	Oxalic Acid	Sodium Sulfate
Ammonium Chloride	Chloracetic Acid	Heptane	Palmitic Acid 10%	Sodium Sulfide
Ammonium Hydroxide 28%	Chloral Hydrate	Hexanol, Tertiary	Perchloric Acid 10%	Sodium Sulfite
Ammonium Metaphosphate	Chlorine Gas (Dry)	Hydrobromic Acid 20%	Phenylhydrazine Hydrochloride	Sodium Thiosulfate (Hypo)
Ammonium Nitrate	Chlorine Gas (Moist)	Hydrochloric Acid 0% - 25%	Phosgene Gas	Stannic Chloride
Ammonium Persulfate	Chlorine Water	Hydrochloric Acid 25% - 40%	Phosphoric Acid – 0-25%	Stannous Chloride
Ammonium Phosphate – Neutral	Chlorosulfonic Acid	Hydrocyanic Acid or Hydrogen Cyanide	Phosphoric Acid – 25-50%	Stearic Acid
Ammonium Sulfate	Chrome Alum	Hydrofluoric Acid 10%	Phosphoric Acid – 50-85%	Sulfur
Ammonium Sulfide	Chromic Acid 10%	Hydrogen Phosphide	Photographic Chemicals	Sulfur Dioxide – Gas Dry
Ammonium Thiocyanate	Chromic Acid 30%	Hydrogen Sulfide – Dry	Plating Solutions	Sulfur Trioxide
Amyl Alcohol	Chromic Acid 40%	Aqueous Solution	Potassium Bicarbonate	Sulfuric Acid – 0-10%
Anthraquinone	Chromic Acid 50%	Hydroquinone	Potassium Bichromate	Sulfuric Acid – 10-75%
Anthraquinonesulfonic Acid	Citric Acid	Hydroxylamine Sulfate	Potassium Borate	Sulfuric Acid – 75-90%
Antimony Trichloride	Copper Chloride	Iodine	Potassium Bromide	Sulfurous Acid
Aqua Regia	Copper Cyanide	Kerosene	Potassium Carbonate	Tannic Acid
Arsenic Acid 80%	Copper Fluoride	Lactic Acid 28%	Potassium Chloride	Tanning Liquors
Arylsulfonic Acid	Copper Nitrate	Lauric Acid	Potassium Chromate	Tartaric Acid
Barium Carbonate	Copper Sulfate	Lauryl Chloride	Potassium Cyanide	Titanium Tetrachloride
Barium Chloride	Cottonseed Oil	Lauryl Sulfate	Potassium Dichromate	Triethanolamine
Barium Hydroxide	Cresylic Acid 50%	Lead Acetate	Potassium Ferricyanide	Trimethyl Propane
Barium Sulfate	Crude Oil – Sour	Lime Sulfur	Potassium Ferrocyanide	Trisodium Phosphate
Barium Sulfide	Crude Oil – Sweet	Linoleic Acid	Potassium Fluoride	Turpentine
Beet – Sugar Liquor	Demineralized Water	Linseed Oil	Potassium Hydroxide	Urea
Benzine Sulfonic Acid 10%	Dextrin	Lubricating Oils	Potassium Nitrate	Vinegar
Benzoic Acid	Dextrose	Magnesium Carbonate	Potassium Perborate	Whiskey
Bismuth Carbonate	Diglycolic Acid	Magnesium Chloride	Potassium Perchlorate	White Liquor (Paper Industry)
Black Liquor (Paper Industry)	Disodium Phosphate	Magnesium Hydroxide	Potassium Permanganate 10%	Wines
Bleach – 12.5% Active Cl	Ethyl Alcohol	Magnesium Nitrate	Potassium Persulfate	Zinc Chloride
Borax	Ethylene Glycol	Magnesium Sulfate	Potassium Sulfate	Zinc Chromate
Boric Acid	Fatty Acids	Maleic Acid	Propane	Zinc Cyanide
Brine	Ferric Chloride	Maleic Acid	Propyl Alcohol	Zinc Nitrate
Breeder Pellets – Dane, Fish	Ferric Nitrate	Mercuric Chloride	Silicic Acid	Zinc Sulfate
Bromic Acid	Ferric Sulfate	Mercuric Chloride	Silver Cyanide	
Bromine – Water	Ferrous Chloride	Mercuric Cyanide	Silver Nitrate	
Butane	Ferrous Sulfate		Silver Plating Solutions	
Butadiene			Sodium Acetate	

Rigid Nonmetallic Conduit – Specification Format

Suggested Format for Specifying Carlon Nonmetallic Conduit, Conduit Fittings and Junction Boxes

- A.** The Carlon rigid nonmetallic conduit system shall be installed as indicated on the drawings and as specified herein.
- B.** All wiring shall be installed in Carlon rigid nonmetallic conduit. All conduit shall be secured by means of proper fittings. All fittings shall be Carlon.
- C.** Carlon outlet boxes, fittings and junction boxes shall be used for all outlets, pull boxes and junction points. (Lighting fixtures shall not be supported or hung from PVC junction boxes but be supported in position by other means.)
- D.** Exposed conduits shall be mounted securely by suitable hangers or straps with the maximum spacing of points of supports not greater than indicated by Section 352.30 of the NEC.
- E.** Except where embedded in concrete or direct buried, Carlon conduit shall be supported to permit adequate lineal movement to allow for expansion and contraction of conduit due to temperature change.
- F.** For aboveground installations where temperature change in excess of 14°C (25°F) is anticipated, expansion joints shall be installed. See Table 352.44(A) NEC for expansion characteristics.
- G.** Proper care shall be taken when field bending is employed to maintain the internal diameter and wall thickness of the conduit.

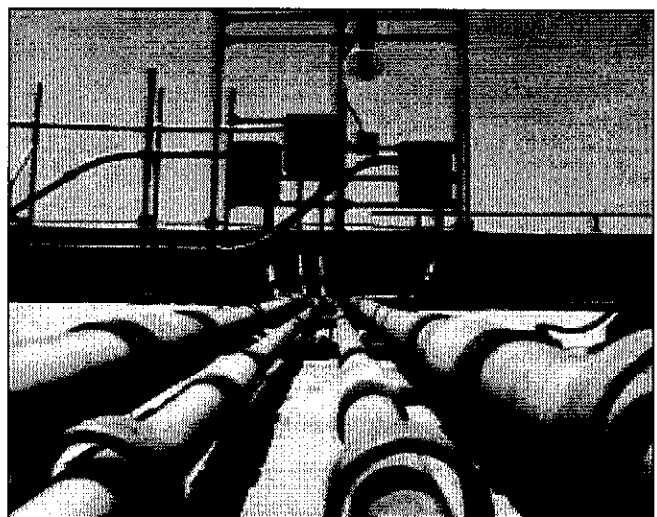
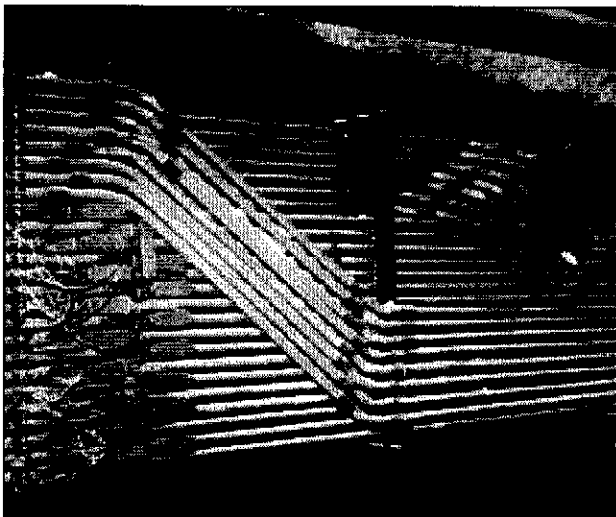
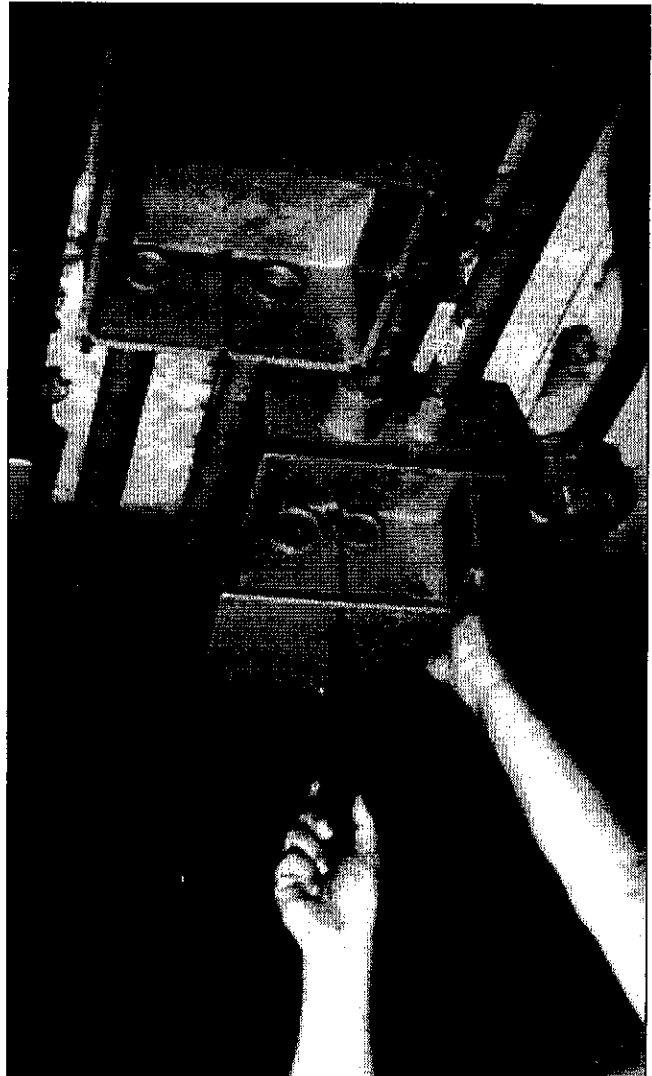

Carlton® Cements, Primers and Sealers

Spray Cement
Medium Clear
Medium Gray
Regular Clear
Regular Gray
Low VOC Gray

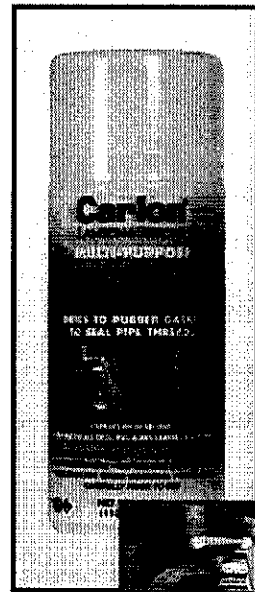
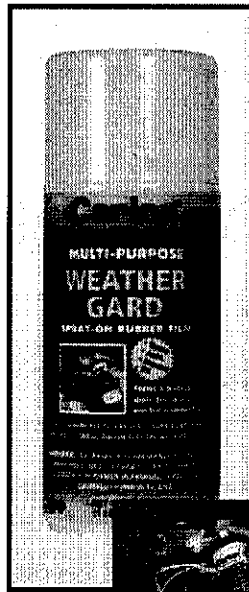
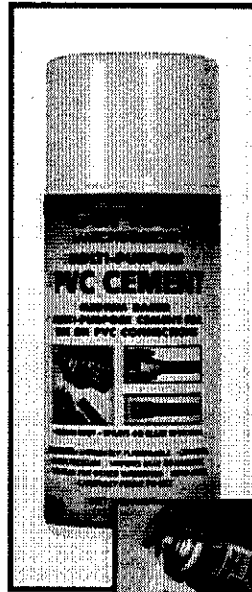

Primers

Spray Sealers

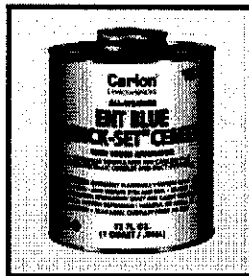
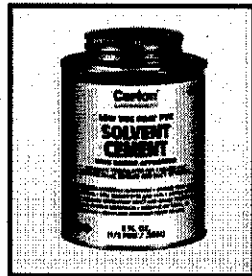

*Innovative Solutions For
Wire and Cable Management*

Medium – Clear

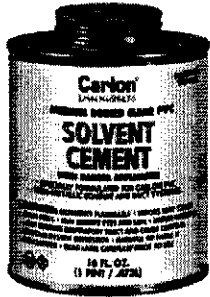

Recommended pipe application and sizes	Set-up time (Evaporation Rate)	Recommended installation temp.	Lap Shear @ 73°F	Viscosity at 75° as manufactured
Recommended for all grades and types of Carlon PVC conduit, duct, wireway and fittings, except Flex-Plus® Blue™ ENT (Electrical Nonmetallic Tubing.) Up through 6" diameter.	10°-30°F Not recommended 30°-50°F 5-6 minutes 50°-70°F 3-4 minutes 70°-90°F 1-2 minutes	40° to 100°F	2 hrs. 350 psi 16 hrs. 800 psi 72 hrs. 1,500 psi	500-900 cps

Part No	Size	Applicator	Description	Ctn. Qty.	Ctn. Wt. (lbs.)
VC9963	Pint	Dauber	PVC Medium Clear	24	29.0
VC9962	Quart	Dauber	PVC Medium Clear	12	27.5
VC9961P	Gallon	-	PVC Medium Clear	6	53.5

Meets ASTM D-2564

Medium – Gray

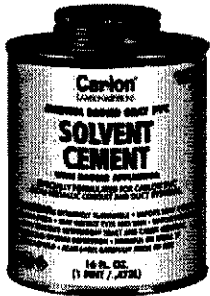

Recommended pipe application and sizes	Set-up time (Evaporation Rate)	Recommended installation temp.	Lap Shear @ 73°F	Viscosity at 75° as manufactured
Recommended for all grades and types of Carlon PVC conduit, duct, wireway and fittings, except Flex-Plus® Blue™ ENT (Electrical Nonmetallic Tubing.) Up through 6" diameter.	10°-30°F Not recommended 30°-50°F 5-6 minutes 50°-70°F 3-4 minutes 70°-90°F 1-2 minutes	40° to 100°F	2 hrs. 350 psi 16 hrs. 800 psi 72 hrs. 1,500 psi	500-900 cps

Part No	Size	Applicator	Description	Ctn. Qty.	Ctn. Wt. (lbs.)
VC9923	Pint	Dauber	PVC Medium Gray	24	29.0
VC9922	Quart	Dauber	PVC Medium Gray	12	27.5
VC9941P	Gallon	-	PVC Medium Gray	6	53.5

Meets ASTM D-2564

Regular – Clear

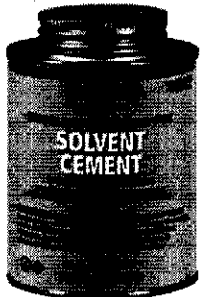

Recommended pipe application and sizes	Set-up time (Evaporation Rate)	Recommended installation temp.	Lap Shear @ 73°F	Viscosity at 75° as manufactured
Recommended for all grades and types of Carlon PVC conduit, duct, wireway and fittings, except Flex-Plus® Blue™ ENT (Electrical Nonmetallic Tubing.) Up through 6" diameter.	10°-30°F Not recommended 30°-50°F 5-6 minutes 50°-70°F 3-4 minutes 70°-90°F 1-2 minutes	40° to 100°F	2 hrs. 350 psi 16 hrs. 800 psi 72 hrs. 1,500 psi	500-900 cps

Part No	Size	Applicator	Description	Ctn. Qty.	Ctn. Wt. (lbs.)
VC9964	1/2 Pint	Dauber	PVC Regular Clear	10	29.06.5

Meets ASTM D-2564

Regular – Gray

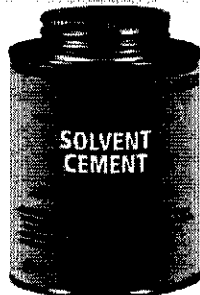

Recommended pipe application and sizes	Set-up time (Evaporation Rate)	Recommended installation temp.	Lap Shear @ 73°F	Viscosity at 75° as manufactured
Recommended for all grades and types of Carlon PVC conduit, duct, wireway and fittings, except Flex-Plus® Blue™ ENT (Electrical Nonmetallic Tubing.) Up through 6" diameter.	10°-30°F Not recommended 30°-50°F 5-6 minutes 50°-70°F 3-4 minutes 70°-90°F 1-2 minutes	40° to 100°F	2 hrs. 350 psi 16 hrs. 800 psi 72 hrs. 1,500 psi	500-900 cps

Part No	Size	Applicator	Description	Ctn. Qty.	Ctn. Wt. (lbs.)
VC9924-24	1/2 Pint	Dauber	PVC Regular Gray	24	15.0

Meets ASTM D-2564

All Weather - Clear



Recommended pipe application and sizes	Set-up time (Evaporation Rate)	Recommended installation temperature	Lap Shear @ 73°F	Viscosity at 75° as manufactured
Recommended for all grades and types of Carlon PVC conduit, duct, wireway and fittings, except Flex-Plus® Blue™ ENT (Electrical Nonmetallic Tubing.) Up through 6" diameter.	-5°-10°F 6-8 minutes 10°-30°F 4-5 minutes 30°-50°F 3-4 minutes 50°-70°F 1-2 minutes 70°-90°F 1/2-1 1/2 minutes	-5° to 100°F	2 hrs. 350 psi 16 hrs. 800 psi 72 hrs. 1,500 psi	400-700 cps

Part No	Size	Applicator	Description	Ctn. Qty.	Ctn. Wt. (lbs.)
VC9984	1/2 Pint	Dauber	All Weather "Quick-Set" Cement	10	7.0
VC9983	Pint	Dauber	All Weather "Quick-Set" Cement	24	30.0
VC9982	Quart	Dauber	All Weather "Quick-Set" Cement	12	29.0
VC9981P	Gallon	-	All Weather "Quick-Set" Cement	6	54.0

Meets ASTM D-2564

All Weather - ENT Blue



Recommended pipe application and sizes	Set-up time (Evaporation Rate)	Recommended installation temperature	Lap Shear @ 73°F	Viscosity at 75° as manufactured
Required for use with Flex-Plus® Blue™ ENT (Electrical Nonmetallic Tubing), Riser-Gard®, P&C Flex®, and Carlon PVC fittings. Up through 6" diameter.	-5°-10°F 6-8 minutes 10°-30°F 4-5 minutes 30°-50°F 3-4 minutes 50°-70°F 1-2 minutes 70°-90°F 1/2-1 1/2 minutes	-5° to 100°F	2 hrs. 350 psi 16 hrs. 800 psi 72 hrs. 1,500 psi	400-700 cps

Part No	Size	Applicator	Description	Ctn. Qty.	Ctn. Wt. (lbs.)
VC9992	Quart	Dauber	All Weather "Quick-Set" Blue	12	29.0

Meets ASTM D-2564

Resi-Gard® - Clear



Recommended pipe application and sizes	Set-up time (Evaporation Rate)	Recommended installation temperature	Lap Shear @ 73°F	Viscosity at 75° as manufactured
For use with Resi-Gard®, Riser-Gard®, P&C Flex®, and Carlon PVC fittings. Up through 6" diameter.	10°-30°F Use extra caution 30°-50°F 5-6 minutes 50°-70°F 3-4 minutes 70°-90°F 1-2 minutes	40° to 100°F	2 hrs. 350 psi 16 hrs. 800 psi 72 hrs. 1,500 psi	500-900 cps

Part No	Size	Applicator	Description	Ctn. Qty.	Ctn. Wt. (lbs.)
VC9963SC	Pint	Brush	Resi-Gard® Solvent Cement Clear	24	28.0

Meets ASTM D-2564

Clear Primer

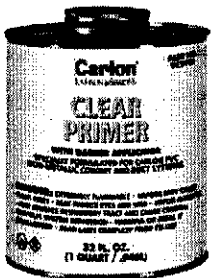

Recommended pipe application and sizes	Recommended installation temperature
Recommended for use with Carlon cement	5° to 100°F

Part No	Size	Applicator	Ctn. Qty.	Ctn. Wt. (lbs.)
VC9903	Pint	Dauber	24	27.0
VC9902	Quart	Dauber	12	25.0

Meets ASTM F-686

Purple Primer

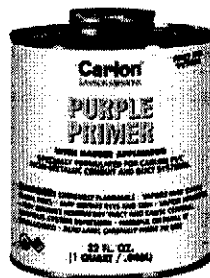

Recommended pipe application and sizes	Recommended installation temperature
Recommended for use with Carlon cement	5° to 100°F

Part No	Size	Applicator	Ctn. Qty.	Ctn. Wt. (lbs.)
VC9932	Quart	Dauber	12	25.0

Meets ASTM F-686

Cement Joints

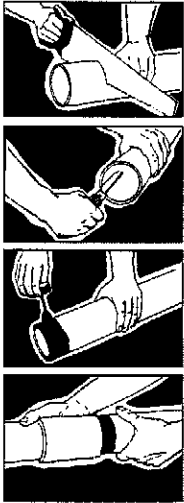

Carlton nonmetallic products are joined by means of solvent cement joints. Sizes 1/2" through 1 1/2" should be cut square (using a fine tooth handsaw) and deburred. For sizes 2" through 6" a miter box or similar saw guide should be utilized to keep the material steady. After cutting and deburring, wipe ends clean of dust, dirt and shavings.

Joining process as follows: Be sure that conduit end is clean and dry. Apply coat of Carlton Solvent Cement (use dauber) to end of conduit, the length of the socket to be attached. Push conduit firmly into fitting while rotating conduit slightly about one-quarter turn to spread cement evenly. Allow joint to set approximately 10 minutes.

Carlton recommends the use of Carlton cement for proper solvent cement joints. Since this cement is prepared particularly for our product

compounds and tolerances, we cannot guarantee joints assembled with cement materials supplied by other manufacturers. Regular grade grey solvent cement will accommodate most application situations being of a general purpose nature. In situations requiring an extremely fast-setting joint, (low temperature or difficult installation conditions) Carlton All Weather Quick-Set Cement is recommended. Standard grade clear cement is recommended for noncritical utility applications where gap filling and leak testing are not required.

Average number of joints per can

Pipe size	1/2 Pint 8 oz.	Pint 16 oz.	Quart 32 oz.	Gallon 128 oz.	Spray 4 oz.	Spray 16 oz.
1/2	140	275	550	2,200	70	275
3/4	90	180	360	1,440	45	180
1	70	140	280	1,120	35	140
1 1/4	50	100	200	800	25	100
1 1/2	37	75	150	600	18.5	75
2	20	40	80	320	10	40
2 1/2	17	35	70	280	8.5	35
3	15	30	60	240	7.5	30
3 1/2	13	27	54	216	6.5	27
4	12	25	50	200	6	25
5	9	19	38	150	N/A	N/A
6	6	12	24	95	N/A	N/A

CAN: Average shelf-life of all Carlton cement is 24 months (unopened cans stored below 80°F.)

SPRAY: Average shelf-life of all Carlton Spray PVC Cement is 3 years.

All Carlton cements are specially formulated to be used with Carlton PVC products, and do not require primers when parts are clean of dirt and moisture.

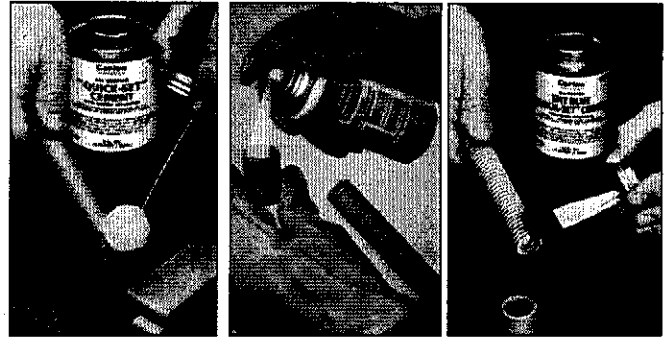

Cementing PVC Conduit:

1. Make square saw cut with fine tooth saw.
2. Deburr and round inside edge of the cut end.
3. Clean socket ID and spigot OD of dirt and moisture.
4. Apply a uniform coat of cement to spigot end and push onto socket bottom, rotating 1/4 turn.
5. Allow time to set before disturbing. This will depend upon temperature.

Cementing PVC Conduit for Submerged Areas Requiring Air or Water Tightness:

1. Follow the procedure to the left for cementing conduit.
2. Test workmanship by conducting a low pressure air (3.0 - 5.0 psi) test after system is installed and cemented joints are set.
3. Plug and block ends to prevent movement prior to pressurization.
4. Check for leaks with soap solution.
5. Even low pressure air can cause high thrust loads and caution must be observed.

Cementing ENT for Concrete-Tight Applications:

1. Use Carlton Socket tight fittings or couplings.
2. **Do not** use chemical primer or cleaner.
3. Apply a light uniform coat of cement, labeled for use with ENT.
4. A **brush** shall be used to apply the cement.
5. Brush excess cement out of ENT grooves
6. Promptly insert ENT into fitting while cement is wet, until the fitting stop is reached, and give 1/4 turn.
7. Do not disturb until the joint is set.

MSDS available at www.carlton.com

Carlton[®]
LAMSON & SESSIONS

In USA, contact:

25701 Science Park Drive • Cleveland, Ohio 44122

1-800-3-CARLON (1-800-322-7566)

In Ohio, (216) 464-3400 • Fax: (216) 766-6444

TDD/Hearing Impaired Access (216) 831-5918 • www.carlton.com

In Canada, contact:

Lamson & Sessions Ltd. • 121 Watline Avenue

Mississauga, ON • Canada L4Z 1P2

(905) 755-1262 • (888) 269-9902

Fax: (905) 755-1265 • (888) 269-8622

Allied E-Z PULL® EMT

Quality Electrical Metallic Tubing

E-Z to Install

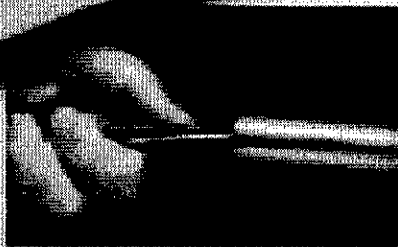

E-Z Wire Pulling

Allied EMT combines strength with ductility, resulting in faster and easier installations. EMT provides easy bending, cutting and joining while resisting flattening, kinking and splitting, creating smooth, continuous raceways for fast wire pulling.

Allied E-Z Pull EMT has a special low friction ID coating that greatly improves the slip properties between conduit and wire. With E-Z Pull, wire pulls through the conduit smoothly and easily.

KWIK-FIT® EMT

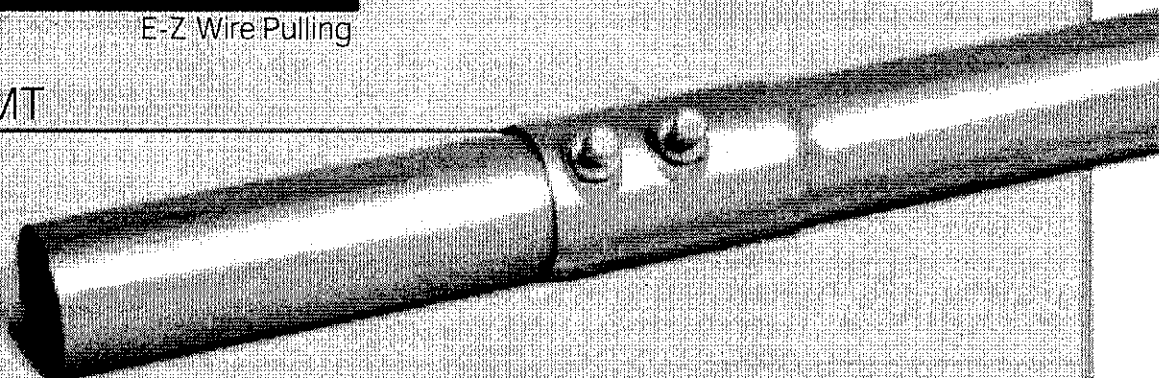

*A new innovation
from the conduit leader*

Allied's Kwik-Fit EMT has an integral steel set-screw coupling formed on one end of each length of EMT. Specifying U.L. listed Kwik-Fit EMT ensures an all steel system — both conduit and coupling for excellent strength and ground return, as well as economy. Contact Allied for detailed specifications on Kwik-Fit EMT. Available in trade sizes 2-4.

 **allied**
TUBE & CONDUIT

Allied E-Z PULL® EMT Specifications

MANUFACTURED FOR LONG LIFE

Allied EMT is precision manufactured from high grade mild strip steel for exceptional durability and long-lasting life.

Allied EMT is hot galvanized using Allied's patented in-line Flo-Coat® process. This process combines zinc, a conversion coating, and a clear organic polymer top-coat to form a triple layer of protection against corrosion and abrasion.

EMI SHIELDING

Allied EMT greatly reduces electromagnetic fields, effectively shielding computers and sensitive electronic equipment from the electromagnetic interference caused by power distribution systems. For further information, visit our website for a free download of the GEMI (Grounding and Electromagnetic Interference) analysis software and related research papers.

FULL CODES AND STANDARDS COMPLIANCE

Allied EMT is listed to Underwriters Laboratories Safety Standard UL 797 and meets ANSI C80.3. The Federal specifications are UL 797 and ANSI C80.3 in lieu of WWC 563. EMT is recognized as an equipment grounding conductor by NEC Section 250-118. Documentation for compliance with NEC Article 250 is available from Allied.

Installation of EMT shall be in accordance with the National Electrical Code and the UL listing information. Allied EMT is listed in category FJMX.

Master bundles conform to NEMA Standard RN2.

SPECIFICATION DATA

To specify Allied EMT, include the following: Electrical Metallic Tubing shall be equal to that manufactured by Allied Tube & Conduit Corporation. EMT shall be hot galvanized steel O.D. with an organic corrosion resistant I.D. coating and shall be produced in accordance with U.L. Safety Standard #797 and ANSI C80.3 and shall be listed by a nationally recognized testing laboratory with follow-up service. Where **Kwik-Fit EMT** is used it shall also meet U.L. Safety Standard #514-B. It is noted that these U.L. and ANSI standards have been adopted by the federal government and separate military specifications no longer exist.

Weights and Dimensions for Electrical Metallic Tubing

Trade Size Designator		Approx. Wt. Per 100 Ft. (30.5M)		Nominal Outside Diameter ¹		Nominal Wall Thickness		Quantity In Master Bundle	
U.S.	Metric	lb.	kg.	in.	mm	in.	mm	ft.	m
1/2	16	30	13.6	0.706	17.9	0.042	1.07	7000	2135.0
3/4	21	46	20.9	0.922	23.4	0.049	1.25	5000	1525.0
1	27	67	30.4	1.163	29.5	0.057	1.45	3000	915.0
1-1/4	35	101	45.8	1.510	38.4	0.065	1.65	2000	610.0
1-1/2	41	116	52.6	1.740	44.2	0.065	1.65	1500	457.5
2	53	148	67.1	2.197	55.8	0.065	1.65	1200	366.0
2-1/2	63	216	98.0	2.875	73.0	0.072	1.83	610	186.1
3	78	263	119.3	3.500	88.9	0.072	1.83	510	155.6
3-1/2	91	249	158.3	4.000	101.6	0.083	2.11	370	112.9
4	103	393	178.2	4.500	114.3	0.083	2.11	300	91.5

¹Outside diameter tolerances: +/- .005 in. (.13mm) for trade sizes 1/2" (16mm) through 2" (53mm); +/- .010 in. (.25mm) for trade sizes 2-1/2" (63mm) +/- .015 in. (.38mm) for trade size 3" (78mm) +/- .020 in. (.51mm) for trade sizes 3-1/2" (91mm) and 4" (103mm).
NOTE: Length = 10 ft. (3.05m) with a tolerance of ± .25" (6.35 mm)

Weights and Dimensions for Kwik-Fit EMT

Trade Size Designator		Approx. Wt. Per 100 Ft. (30.5M)		Nominal Outside Diameter ¹		Nominal Wall Thickness		Quantity In Master Bundle	
U.S.	Metric	lb.	kg.	in.	mm	in.	mm	ft.	m
2	53	148	67.1	2.197	55.8	0.065	1.65	500	152.4
2-1/2	63	216	98.0	2.875	73.0	0.072	1.83	350	106.8
3	78	263	119.3	3.500	88.9	0.072	1.83	300	91.5
3-1/2	91	349	158.3	4.000	101.6	0.083	2.11	250	76.3
4	103	393	178.2	4.500	114.3	0.083	2.11	250	76.3

¹Outside diameter tolerances: +/- .005 in. (.13mm) for trade size 2" (53mm); +/- .010 in. (.25mm) for trade size 2-1/2" (63mm); +/- .015 in. (.38mm) for trade size 3" (78mm) +/- .020 in. (.51mm) for trade sizes 3-1/2" (91mm) and 4" (103mm).

NOTE: Length = 10 ft. (3.05m) with a tolerance of ± .25" (6.35 mm)

For more information, contact Allied at (800) 882-5543
or visit our website at www.atcelectrical.com

tyco

Electrical &
Metal Products

AFC Cable Systems® • Allied Tube & Conduit • Cope® Cable Tray • Power-Strut® Metal & Fiberglass Framing



Allied **RIGID**

Quality, Long Lasting Steel Conduit

Heavy Duty

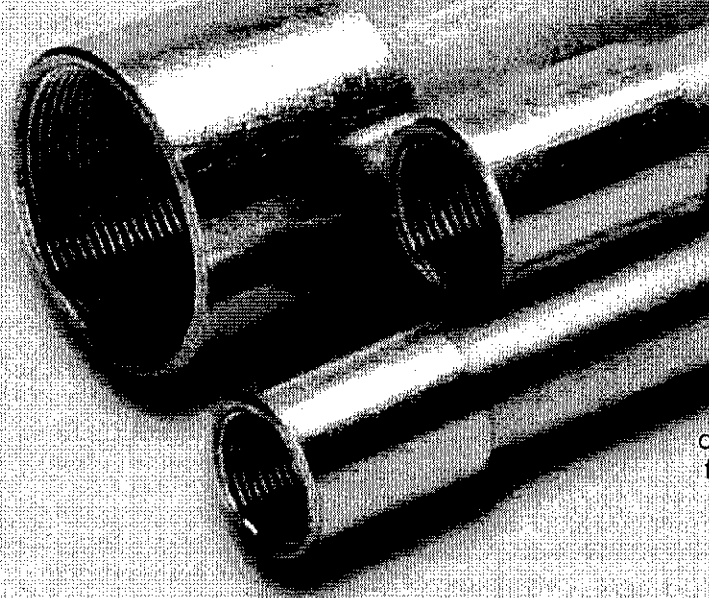

Allied Rigid is precision manufactured for dependable, long-lasting value and protection for the electrical raceway system. Allied Rigid also provides radiation protection, magnetic shielding and resists impact.

Kwik-Couple® RIGID

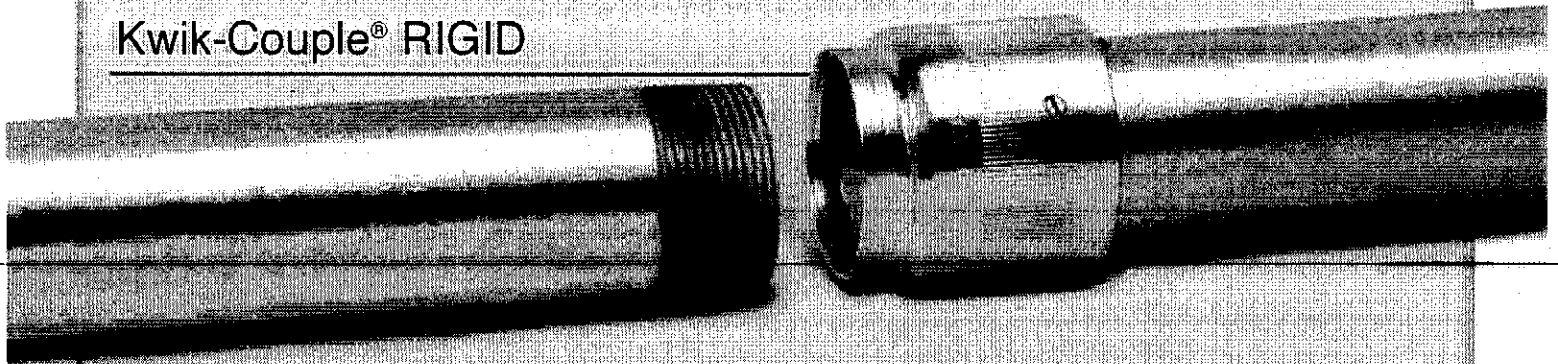

Allied's patented Kwik-Couple Rigid cuts threaded conduit installation time and cost significantly. Kwik-Couple comes installed right on the conduit or elbows, right where you need it. Just line up the ends, spin the coupling forward onto the next piece and wrench tighten. It's that easy!

*U.S. Patent Numbers 4258936, 4547004.

 **allied**
TUBE & CONDUIT

Allied **RIGID** Specifications

PROVIDES FULL ELECTRICAL SYSTEM PROTECTION

Allied RIGID is precision manufactured for dependable, long-lasting value and protection for the electrical raceway system. Manufactured from high-strength steel, Allied RIGID combines damage-resistant strength with ductility to assure easy bending, cutting and joining. It also provides smooth, continuous raceways for fast wire-pulling. No need to worry about damage to the conduit system even when pulling through multiple 90° bends.

Allied RIGID is hot-dipped galvanized inside and out. It is top-coated with a compatible organic layer to inhibit white rust and increase corrosion resistance.

Allied RIGID is impact and crush resistant for maximum conductor protection.

The 3/4" taper NPT threads (ANSI B1.20.1) are full cut and hot galvanized after cutting. Color-coded end-cap thread protectors keep the threads clean and sharp and also provide instant trade size recognition. Even trade sizes are color-coded blue, 1/2 trade sizes are black, and 1/4 trade sizes are red.

EMI SHIELDING

Allied RIGID greatly reduces electromagnetic fields, effectively shielding computers and sensitive electronic equipment from the electromagnetic interference caused by power distribution systems. For further information, visit our website for a free download of the **GEMI** (Grounding and ElectroMagnetic Interference) analysis software and related research papers.

FULL CODES AND STANDARDS COMPLIANCE

Allied RIGID is covered by article 344 of the National Electrical Code. It is listed to Underwriters Laboratories Safety Standard U.L. 6. and is manufactured to ANSI C80.1, both of which have been adopted as Federal Specifications in lieu of WWC 581.

Allied RIGID is recognized as an equipment grounding conductor by NEC Article 250. Documentation for compliance with NEC Article 250 is also available in the **GEMI** (Grounding and ElectroMagnetic Interference) analysis software and related research studies found at the www.alliedeg.com website.

Installation of Rigid Metal Conduit shall be in accordance with the National Electrical Code and U.L. General Information card #DYIX. Master bundles conform to NEMA standard RN2.

SPECIFICATION DATA

RIGID Metal Conduit shall be hot-dip galvanized steel equal to that manufactured by Allied Tube & Conduit Corporation. Threads shall be hot galvanized after cutting. RIGID shall be produced in accordance with U.L. Safety Standard #6 and ANSI C80.1 and shall be listed by a nationally recognized testing laboratory with follow-up service. Where

Kwik-Couple RIGID is used it shall also meet U.L. Safety Standard #514-B. It is noted that these U.L. standards have been adopted by the federal government and separate military specifications no longer exist.

For more information, contact Allied at (800) 882-5543 or visit our website at www.alliedeg.com

Weights and Dimensions for Galvanized Rigid Tubing

Trade Size Designator		Approx. Wt. Per 100 Ft. (30.5M)		Nominal Outside Diameter ¹		Nominal Wall Thickness		Quantity In Master Bundle	
U.S.	Metric	lb.	kg	in.	mm	in.	mm	ft.	m
1/2	16	82	37.2	0.840	21.3	0.104	2.60	2500	762.5
3/4	21	109	49.4	1.050	26.7	0.107	2.70	2000	610.0
1	27	161	73.0	1.315	33.4	0.126	3.20	1250	381.3
1-1/4	35	218	98.9	1.660	42.2	0.133	3.40	900	274.5
1-1/2	41	263	119.3	1.900	48.3	0.138	3.50	800	244.0
2	53	350	158.7	2.375	60.3	0.146	3.70	600	183.0
2-1/2	63	559	253.5	2.875	73.0	0.193	4.90	370	112.9
3	78	727	329.7	3.500	88.9	0.205	5.20	300	91.5
3-1/2	91	880	399.1	4.000	101.6	0.215	5.50	250	76.3
4	103	1030	467.1	4.500	114.3	0.225	5.70	200	61.0
5	129	1400	634.9	5.563	141.3	0.245	6.20	150	45.8
6	155	1840	834.5	6.625	168.3	0.266	6.80	100	30.5

¹ For more information only; not a spec requirement.

NOTE: Length = 10 ft. (3.05m) with a tolerance of +/- .25 in. (6.35mm).

* NEMA Standard

Weights and Dimensions for Kwik-Couple Rigid

Trade Size Designator		Approx. Wt. Per 100 Ft. (30.5M)		Nominal Outside Diameter ¹		Nominal Wall Thickness ²		Quantity In Master Bundle	
U.S.	Metric	lb.	kg	in.	mm	in.	mm	ft.	m
2-1/2	63	559	253.5	2.875	73.0	0.193	4.90	400	122.0
3	78	727	329.7	3.500	88.9	0.205	5.20	300	91.5
3-1/2	91	880	399.1	4.000	101.6	0.215	5.50	250	76.3
4	103	1030	467.1	4.500	114.3	0.225	5.70	200	61.0

¹Outside diameter tolerances: +/- .025 in. (.64mm) ²For information only; not a spec requirement.



Allied Tube & Conduit
Registered to ISO 9001:2000
File Numbers A2106, A1154, A12768

ALLIED ELECTRICAL GROUP

• Allied Tube & Conduit • AFC Cable Systems® • Cope® Cable Tray • Power-Strut® Metal & Fiberglass Framing

www.alliedeg.com

Allied Tube & Conduit, AFC Cable Systems, Cope, Power-Strut, and Tyco are trademarks or registered trademarks of Tyco and/or its affiliates in the United States and in other countries. All other brand names, product names, or trademarks belong to their respective owners.

© Allied Tube & Conduit Printed in U.S.A. ATC-L-1749-0608

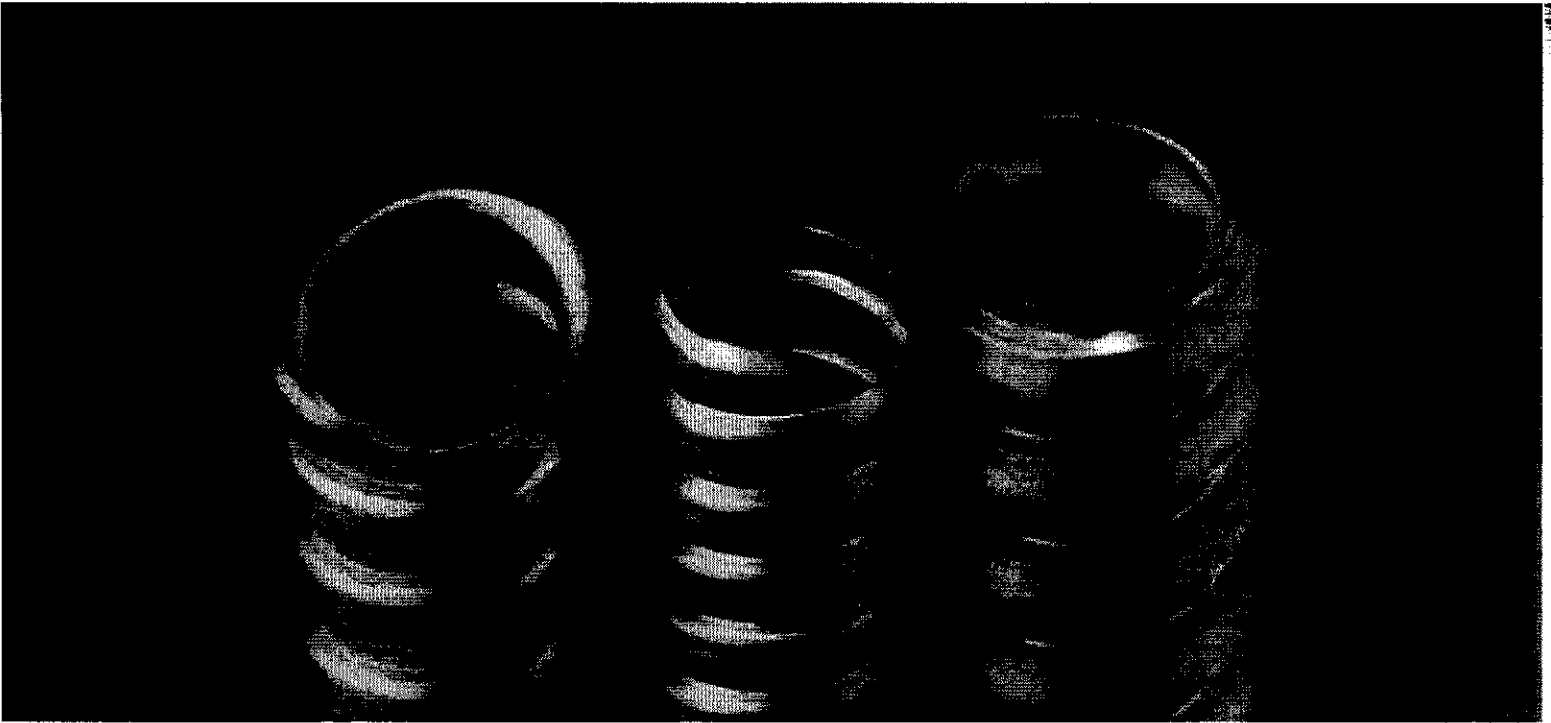

EASTERN

PROTECTION IN DRY ENVIRONMENTS

GREENFIELD and RAYFLEX

Eastern offers a *complete line* of aluminum and steel flexible conduits for use in dry locations.

Eastern's **RAYFLEX** is a heavy wall aluminum conduit which is suitable for all applications where UL and CSA certifications are required.

Our Greenfield **GFAU** is a reduced wall UL aluminum conduit which can be installed anywhere a UL flexible aluminum conduit is required.



GFSU, a reduced wall UL flexible steel conduit, that is suitable anywhere steel is preferred.

GFSN is an extra flexible steel conduit used in those areas where tight bends are required.

RAYFLEX

Trade Size	Inside Diameter (Minimum)	Inside Diameter (Maximum)	Outside Diameter (Minimum)	Outside Diameter (Maximum)	Weight per Meter (Kg)	Bend Diameter (Inches)	Standard Cartons (Meters)	Standard Reels (Meters)
3/8	.375	.394	.560	.610	.096	4	75	150/300
1/2	.625	.645	.860	.920	.25	6	30	150/300
3/4	.812	.835	1.045	1.105	.30	8	30	150/300
1	1.000	1.040	1.300	1.380	.47	10	30	120
1 1/4	1.250	1.300	1.550	1.630	.58	13	15	
1 1/2	1.500	1.575	1.850	1.950	.76	15	15	
2	2.000	2.080	2.350	2.245	.98	20	15	
2 1/2	2.500		2.860	3.060	1.46	25	15	
3	3.000		3.360	3.560	1.67	30	15	
3 1/2	3.500		3.860	4.060	1.89	35	15	
4	4.000		4.360	4.560	2.1	40	15	

Approvals:

* CSA C22.2 No. 56-1961

* ULI, CSA-NRTL

GREENFIELD - GFAU, GFSU, GFSN

Trade Size	Inside Diameter (Minimum)	Inside Diameter (Maximum)	Outside Diameter (Minimum)	Outside Diameter (Maximum)	Bend Diameter (Inches)	Standard Cartons (Feet)	Standard Reels (Feet)
3/8	.375	.393	.560	.610	2	100/250	1000
1/2	.625	.645	.860	.920	3	100	1000
3/4	.812	.835	1.045	1.105	4	100	500
1	1.000	1.040	1.300	1.380	5	50	400
1 1/4	1.250	1.300	1.550	1.630	6.25	50	250
1 1/2	1.500	1.575	1.850	1.950	7.5	25	150
2	2.000	2.080	2.350	2.450	10	25	100
2 1/2	2.500		2.860	3.060	12.5	25	
3	3.000		3.360	3.560	15	25	
3 1/2	3.500		3.860	4.060	17.5	25	
4	4.000		4.360	4.560	20	25	

Approvals:

* ULI, CSA-NRTL (Reduced Wall Aluminum Greenfield-GFAU)

* ULI Listed (Reduced Wall Steel Greenfield-GFSU)

Mono-Tray[®] Aluminum and Steel

Mono-Tray[®] is a unique center-hung cable tray system, which provides organization and support for virtually any cable or wiring installation. Available in both steel and aluminum, Mono-Tray[®] redefines labor-saving with its versatile "lay-in feature".

Full side accessibility allows cable to be laid-in, as opposed to the time consuming, and potentially damaging, effects of cable pulling required with conventional trapeze supports.

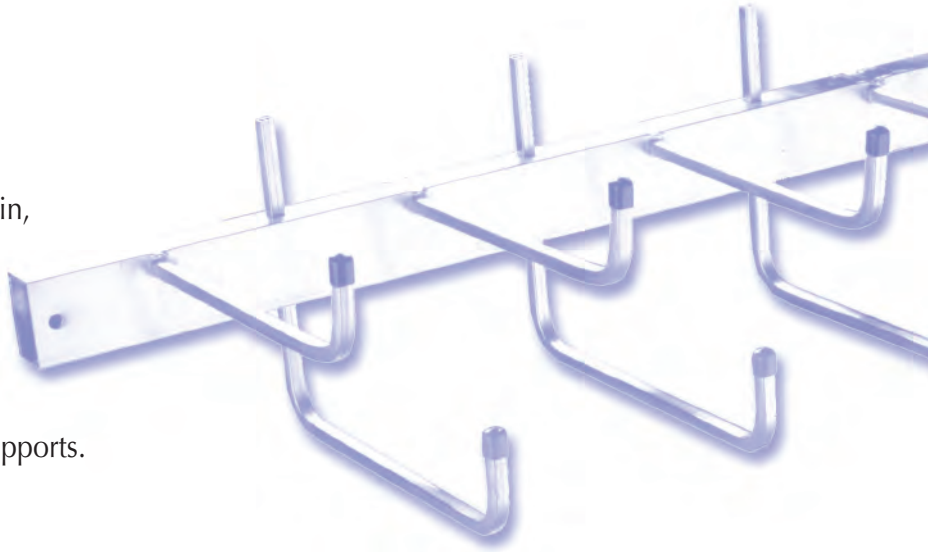

A full line of quick fittings and accessories are available to complete any installation.

UL Listed, CSA Certified. Available in Steel or Aluminum.



Ordering Summary Guide Quick Selector

Example Catalog Number

Bottom Rung Mono-Tray Aluminum, 3" Rung Spacing, 3" High, 12'-0" Length, 6" Wide

B 1 1 5 3 - 0 3 2 1 -

TRAY STYLE		TRAY TYPE		MATERIAL		RUNG SPACING			RUNG HEIGHT			TRAY LENGTH			TRAY WIDTH			RUNG STYLE	
						in	mm	in	mm	ft	m	in	mm	in	mm				
B	Bottom Rung Tray	1	Mono-Tray (Ladder)	1	Aluminum	1	6"	150	3	3"	75	32	12'	3.6	1	6"	150	R	Removable 1/2" (12mm) Type "C" Rung
L	L-Series Top Rung	2	Dual-Rail	2	Pre-Galvanized Steel	2	9"	225	4	4"	100				2	9"	225	D	3/4" (19mm) Type "D" Rung
LB	L-Series Bottom Rung	6	Wall-Rack	3	Hot Dipped Galvanized Steel after Fabrication	3	12"	300	6	6"	150				3	12"	300	RD	Removable 3/4" (19mm) Type "D" Rung
CB	4" High Spine	9	Wall-Rack Double-Tier	4	Epoxy Paint (Aluminum)	4	18"	450							4	18"	450	A	"A" Rung ("L" Series) Only
				5	Epoxy Paint (Steel)	5	3"	75							5	24"	600		
				6	Anodized Aluminum	6	4"	100							6	36"	900		
															7	3"	75		
															8	4"	100		
															9	30"	750		
																		B	"B" Rung

3" Rung spacing not available with "L" Series Tray.

CSA Load Ratings

CSA LOAD RATING						
CSA Load Class	Product Line	Maximum Tray Width		Maximum Rung Spacing		Rung Style
		in	mm	in	mm	
A 37Kg/m/3m	"L"-Series Mono-Tray® Aluminum	12	300	12	300	A, B
	"L"-Series Wall-Rack Aluminum	6	150	12	300	A, B
C1 97Kg/m/3m	Mono-Tray® Aluminum	24	600	6	150	B, C
	Mono-Tray® Aluminum	12	300	12	300	B
	Mono-Tray® Aluminum	9	230	18	450	B
	Wall-Rack Aluminum	12	300	6	150	C, D
	Wall-Rack Steel	12	300	6	150	E
D1 179Kg/m/3m	Mono-Tray® Aluminum	12	300	12	300	B
	Mono-Tray® Aluminum	18	450	9	230	C
	Mono-Tray® Aluminum	24	600	6	150	C
	Mono-Tray® Aluminum	24	600	12	300	D
	Mono-Tray® Steel	24	600	12	300	E
E 299Kg/m/3m	Dual-Rail® Aluminum	36	900	12	300	C
	Dual-Rail® Steel	36	900	12	300	E



Material Data - Aluminum

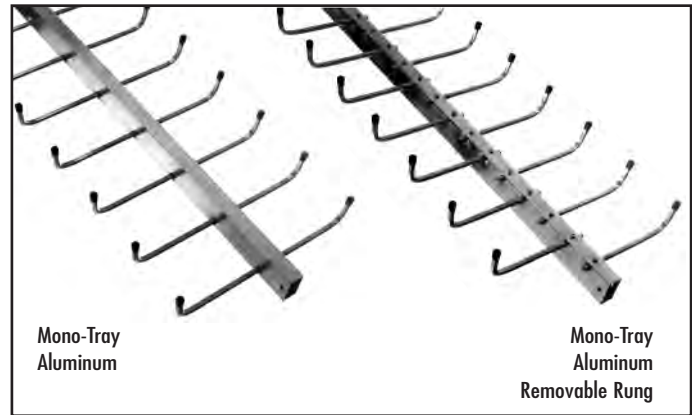
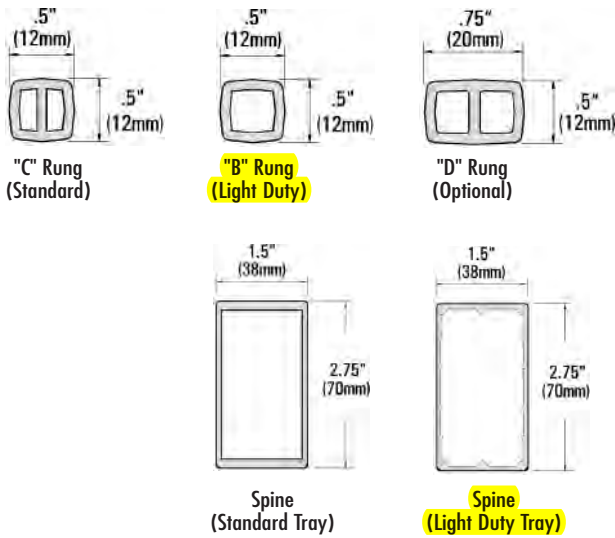

SPINE DEFLECTION @ 100#/ft (149kg/m)					
Spine Type	Support Span		Deflection		NEMA Rating (1.5 Safety Factor)
	ft	m	in	mm	
Standard	12	3.6	2.8	71	12C
Light	12	3.6	3.4	86	12B

Design Data

One splice connector (p/n: 0100-0420) is provided with each tray length.

BOTTOM RUNG WIDTH CHART (ALUMINUM TRAY)		
W	BW	
	in	mm
6	7.5	191
9	10.5	267
12	13.5	343
18	18	450
24	24	600

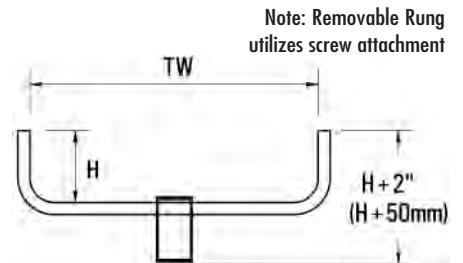
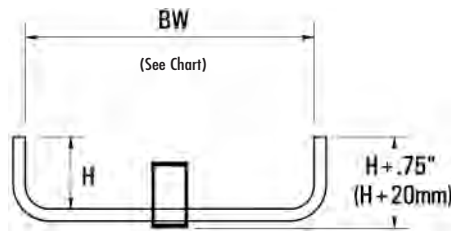

Ordering Data

Example Tray Catalog Number
Bottom Rung Mono-Tray Aluminum, 6" Rung Spacing, 3" High, 12'-0" Length, 6" Wide

B 1 1 1 3 - 0 32 1 -

LB1133-0324-B

TRAY STYLE	MATERIAL	RUNG SPACING	RUNG HEIGHT	TRAY LENGTH	TRAY WIDTH	RUNG STYLE
B Bottom Rung Tray	1 Aluminum	1 6" 150	3 3" 75	32 12' 3.6	1 6" 150	R Removable 1/2" (12mm) Type "C" Rung
L Light Duty Tray	4 Epoxy Paint (Aluminum)	2 9" 225	4 4" 100	35 10' 3.0	2 9" 225	D 3/4" (19mm) Type "D" Rung
LB L-Series Bottom Rung	6 Anodized Aluminum	3 12" 300	6 6" 150		3 12" 300	RD Removable 3/4" (19mm) Type "D" Rung
		4 18" 450			4 18" 450	B "B" Hollow Rung
		5 3" 75			5 24" 600	
		6 4" 100			7 3" 75	
					8 4" 100	

For Top Rung Standard Spine Tray No Letter Prefix is required.

3" R.S. for Standard Tray Only. Not available in "L" Series
18" R.S. only for 6" & 9" widths.
12" R.S. only for 6", 9" & 12" widths.

For Standard Type "C" Aluminum Fixed Rung. No Letter Suffix is required.
Removable Rung is not available for Double Tier.



PART 1 - GENERAL

1.10 REFERENCE STANDARDS:

- A. Underwriter's Laboratories, Inc. certified No. E80034; National Electrical Code 318; NEMA class 12C (100#/ft./12 ft.) for Mono-Tray, L-Series NEMA 12A - 50#/ft./12ft..
- B. Canadian Standards Association No. LR 082927, Mono-Tray 3 meter sections are CSA classified 3C12 and 3D12 (179kg/m/3m). L-Series Mono-Tray CSA classified 3A2 (37kg/m/3m).
- C. The cable tray system components shall be certified by one of the following UL, C-UL, CSA and/or a recognized testing laboratory.

1.20 DESCRIPTION:

- A. Complete center hung and/or wall mounted steel or aluminum (select one) cable tray system and necessary accessories shall be provided as shown on plans. Install entire cable tray system in accordance with all local governing codes.

1.30 SUBMITTALS:

- A. Submittal drawings, in the form of 8 1/2 x 11 catalog cut sheets, shall be provided for the following items: cable trays, fittings, accessories and load data.

PART 2 - PRODUCTS

2.10 MATERIALS - Steel or Aluminum (SELECT 3A or B2)

- A. Steel cable trays shall be ventilated ladder type construction with widths and depths as indicated on the drawings. The ladder tray shall be supported from one (1) steel splice connector, installed in a telescoping manner, around the outer portion of the main spine members.
- B. Aluminum cable trays shall be ventilated ladder type construction with widths and depths as indicated on the drawings. The ladder tray shall be supported from one (1) aluminum splice connector, installed inside the inner portion of the main spine members.

2.20 CENTER HUNG Mono-Tray - Steel or Aluminum (SELECT 3A or B2)

- A. Steel Mono-Tray shall be constructed of one (1) 12x32 rectangular seam welded steel tube to which .6252 square seam welded tube steel rungs are attached on ____ inch (mm) centers. The cross rungs shall be bent up at their ends to a height of ____ inches (mm) to form a center supported, open sided, ladder type assembly. The tray shall be ____ inches (mm) wide and must not have continuous side rails. As noted on drawings, rungs shall emanate at right angles from the top of the spine or bottom of the spine (select one).
- B. Aluminum Mono-Tray Ladder Tray shall be constructed of one (1) 1.52x2.752 rectangular extruded aluminum tube to which 1/2" square box beam (type C standard) or 3/4" x 1/2" box beam (type D) (select one) rungs are attached on ____ inch (mm) centers. The cross rungs shall be bent up at their ends to a height of ____ inches (mm) to form a dual supported, open sided, ladder type assembly. The tray must not have continuous side rails. As noted on drawings, rungs shall emanate at right angles from the top of the spine or bottom of the spine (select one). L-Series Mono-Tray shall have 1/2" solid aluminum triangular (type B) rungs.

2.30 WALL RACK LADDER TRAY - Steel or Aluminum (SELECT 3A or B2)

- A. Steel Wall Rack tray shall be constructed of one (1) 12x32 rectangular seam welded steel tubes to which .6252 square seam welded tube steel rungs are attached on ____ inch (mm) centers. The cross rungs shall emanate from one side of the spine and shall be bent up at their ends to a height of ____ inches (mm) to form an open sided, ladder type assembly. The tray shall be ____ inches (mm) wide and must not have continuous side rails. As noted on drawings, rungs shall emanate at right angles from the top of the spine or bottom of the spine (select one).
- B. Aluminum Wall Rack tray shall be constructed of one (1) 1.52x2.752 rectangular extruded aluminum tube to which 1/2" square box beam (type C standard) or 3/4" x 1/2" box beam (type D) rungs are attached on ____ inch (mm) centers. The cross rungs shall be emanate from one side of the spine and shall be bent up at their ends to a height of ____ inches (mm) to an open sided, ladder type assembly. The tray must not have continuous side rails. As noted on drawings, rungs shall emanate at right angles from the top of the spine or bottom of the spine (select one). L-Series Wall Rack shall have 1/2" solid aluminum triangular (type B) rungs.

2.40 DOUBLE TIER WALL RACK LADDER TRAY - Aluminum Only

- A. Aluminum Wall Rack Double Tier tray shall be constructed of one (1) 1.52x2.752 rectangular extruded aluminum tube to which 1/2" square box beam (type C standard) rungs are attached on ____ inch (mm) centers. These cross rungs shall emanate from one side (top of the spine only) and also vertically from the bottom of the spine to form two tiers of cable tray, one above the other and shall be bent up at their ends to a height of ____ inches (mm) to an open sided, ladder type assembly. The tray must not have continuous side rails. Tray shall be mounted by fastening the spine directly to the wall in accordance with manufacturer's specifications.

2.50 FITTINGS

- A. Splice Connectors - Steel or Aluminum (select one). Sections of Mono-Tray, Wall Rack and/or Double Tier Wall Rack and all other fittings shall be joined by using one (1), two bolt, 4 inch (102mm) long, rectangular splice connector which telescope about the spine of the tray. Splice connectors shall allow for thermal expansion/contraction of the tray system. The splice connectors shall be provided with a vertical hole to accept a 1/2 inch (12mm) threaded rod (furnished by others) which is used to support the tray in an overhead application. In addition, steel splice connectors shall be installed with the seam up and shall have holes to accommodate mounting configurations associated with horizontal and vertical pivot connectors.
- B. Quick Tee and Quick Cross Connectors. Horizontal and Vertical quick connect items shall be used for all 90 degree elbows. Quick Tees and Crosses shall have factory installed splice connector(s) welded to the component assembly.
- C. Horizontal and Vertical Pivot Connectors - Angle tray connections to be field installed with Horizontal and Vertical pivot connectors. Fittings and shall telescope about the spine in a similar manner as the above splice connectors with top or side mounted pivot plates.
- D. Tray Inserts / Tray Covers - Steel or Aluminum (select one), as well as other accessories shall be constructed of compatible material and design. Inserts and covers shall be field installed and rigidly secured by means of self tapping screws.

2.60 CONSTRUCTION

- A. The Mono-Tray, Wall Rack and/or Double Tier Wall Rack rungs must pass through sections of spine and be staked in place, not screwed or welded. Each tray length shall consist of one tubular rectangular shaped spine member. All fittings and accessories to be constructed of steel or aluminum (select one) and to be manufactured for use with cable tray system.

2.70 SUPPORTS

- A. Each Mono-Tray, Wall Rack and/or Double Tier Wall Rack ladder tray section shall be supported on maximum 12 foot centers (3.6 meters) in Canada 10 foot centers (3 meters) by one .50 inch (12mm) piece of threaded rod which pass through the vertical hole in each of the splice connectors and fasten directly to each piece of spine by one .50 inch (12mm) nut and washer on both the top and bottom sides of each piece spine. When shorter spans are required, then a 5/8 inch (16 mm) diameter hole should be drilled through the top and bottom walls of each piece of spine at support points only, and a single .50 inch (12mm) threaded rod should be inserted, through each spine member, also using a .50 inch (12mm) nut and washer on both the top and bottom sides of the spine.
- B. Wall Mounted Mono-Tray Steel or Aluminum (select one) Ladder Tray - shall utilize wall bracket of adequate widths to accommodate Mono-Tray configuration. Brackets to be Mono-Systems, Inc. Series 0100-047_. All mounting material shall be furnished and installed by others.

2.80 OPTIONAL PAINTED FINISHES

- A. Optional powder coated painted finish to be applied to the outer surfaces of the cable tray and associated components. Prior to the application of the powder coat all surfaces shall be cleaned and have an iron phosphate film applied. The color shall be _____.

PART 3 - MANUFACTURER

3.10 MANUFACTURER

- A. Company specializing in manufacturing products specified in this section must have a minimum of ten years documented experience. Unless written approval is obtained from the engineer 14 days prior to bid, the cable tray and fittings shall be manufactured by: Mono-Systems, Inc., 4 International Drive, Rye Brook New York 10573. (TEL) 914-934-2075 (FAX) 914-934-2190.

PART 1 - GENERAL

- 1.10 REFERENCE STANDARDS:**
- A. Underwriter's Laboratories, Inc. certified No. E80034; National Electrical Code 318; NEMA class 12C (100#/ft./12 ft.).
 - B. Canadian Standards Association No. LR 082927, Dual-Rail 3 meter sections are CSA classified "E" (299kg/m/3m).
 - C. The cable tray system components shall be certified by one of the following UL, C-UL, CSA and/or a recognized testing laboratory.
- 1.20 DESCRIPTION:**
- A. Complete assembly of steel or aluminum (select one) cable tray system and necessary accessories shall be provided as shown on plans. Install entire cable tray system in accordance with all local governing codes.
- 1.30 SUBMITTALS:**
- A. Submittal drawings, in the form of 8 " x 11" catalog cut sheets, shall be provided for the following items: cable trays, fittings, accessories and load data.

PART 2 - PRODUCTS

- 2.10 MATERIALS (SELECT "A or B")**
- A. Steel Dual-Rail shall be ventilated ladder type construction with widths and depths as indicated on the drawings. The ladder tray shall be supported from two (2) steel splice connectors, installed in a telescoping manner, around the outer portion of the main spine members.
 - B. Aluminum Dual-Rail shall be ventilated ladder type construction with widths and depths as indicated on the drawings. The ladder tray shall be supported from two (2) aluminum splice connectors, installed inside the inner portion of the main spine members.
- 2.20 Dual-Rail® LADDER TRAY - Steel or Aluminum (SELECT "A or B")**
- A. Steel Dual-Rail Ladder Tray shall be constructed of two (2) 1"x3" rectangular seam welded steel tubes to which .625" square seam welded tube steel rungs are attached on ____ inch (mm) centers. The cross rungs shall be bent up at their ends to a height of ____ inches (mm) to form a dual supported, open sided, ladder type assembly. The tray must not have continuous side rails. As noted on drawings, rungs shall emanate at right angles from the top of the spine or bottom of the spine (select one).
 - B. Aluminum Dual-Rail Ladder Tray shall be constructed of two (2) 1.5"x2.75" rectangular extruded aluminum tubes to which " square box beam (type C standard) or " x " box beam (type D) (select one) rungs are attached on ____ inch (mm) centers. The cross rungs shall be bent up at their ends to a height of ____ inches (mm) to form a dual supported, open sided, ladder type assembly. The tray must not have continuous side rails. As noted on drawings, rungs shall emanate at right angles from the top of the spine or bottom of the spine (select one).
- 2.30 FITTINGS**
- A. Splice Connectors - Steel or Aluminum (select one). Sections of Dual-Rail tray and all other fittings shall be joined by using two (2), two bolt, 4 inch (102mm) long, rectangular splice connectors which telescope about the spine of the tray. Splice connectors shall allow for thermal expansion/contraction of the tray system. The splice connectors shall be provided with a vertical hole to accept a 1/2 inch (12mm) threaded rod (furnished by others) which is used to support the tray in an overhead application. In addition, steel splice connectors shall be installed with the welded seam up and shall have holes to accommodate mounting configurations associated with horizontal and vertical pivot connectors.
 - B. Quick Tee - Steel or Aluminum (select one), Horizontal and Vertical quick connect items shall be used for all 90 degree elbows, tees and crosses by clamping to the spine(s).
 - C. Horizontal and Vertical Pivot Connectors - Steel or Aluminum (select one), shall be used for angles of 90 degrees to 30 degrees and fasten into the spine in a similar manner as the above splice connectors with top or side mounted pivot plates.
 - D. Tray Inserts / Tray Covers - Steel or Aluminum (select one), as well as other accessories shall be constructed of compatible material and design. Inserts and covers shall be field installed and rigidly secured by means of self tapping screws.
- 2.40 CONSTRUCTION**
- A. The Dual-Rail rungs must pass through both sections of spine and be staked in place, not screwed or welded. Each tray length shall consist of two parallel spine members, each being a tubular rectangular shape. All fittings and accessories to be constructed of steel or aluminum (select one) and to be manufactured for use with cable tray system.
- 2.50 SUPPORTS**
- A. Each Dual-Rail Steel or Aluminum (select one). Ladder Tray section shall be supported on maximum 12 foot centers (3.6 meters) in Canada 10 foot centers (3 meters) by two .50 inch (12mm) pieces of threaded rod which pass through the vertical hole in each of the splice connectors and fasten directly to each piece of spine by one .50 inch (12mm) nut and washer on both the top and bottom sides of each piece spine. When shorter spans are needed, then a 5/8 inch (16 mm) diameter hole should be drilled through the top and bottom walls of each piece of spine at support points only, and a single .50 inch (12mm) threaded rod should be inserted, through each spine member, also using a .50 inch (12mm) nut and washer on both the top and bottom sides of each piece of spine. All mounting material shall be furnished and installed by others.
- 2.60 OPTIONAL PAINTED FINISHES**
- A. Optional powder coated painted finish to be applied to the outer surfaces of the cable tray and associated components. Prior to the application of the powder coat all surfaces shall be cleaned and have an iron phosphate film applied. The color shall be _____.

PART 3 - MANUFACTURER

- 3.10 MANUFACTURER**
- A. Company specializing in manufacturing products specified in this section must have a minimum of ten years documented experience. The cable tray and fittings shall be manufactured by: Mono-Systems, Inc., 4 International Drive, Rye Brook New York 10573. (TEL) 914-934-2075 (FAX) 914-934-2190.

Home	Products	Customer Service	About Intermatic	Buy Online
----------------------	--------------------------	----------------------------------	----------------------------------	----------------------------

[Home](#) » [Timers](#) » [In-Wall Timers](#) » [Commercial Spring Wound Timers](#)

Consumer Indoor
Timers
Consumer Outdoor
Timers
Electronic Time
Switches
In-Wall Timers

[24-Hour Mechanical
Time Switches](#)
[Commercial Spring
Wound Timers](#)
[Compact
Programmable
Timers](#)
[Decorator Spring
Wound Timers](#)
[Digital 7-Day Time
Switches](#)
[Digital Auto-Off
Timers](#)
[Electronic 7-Day
Astro Time Switches](#)
[Electronic Auto-Off
Timers](#)

Mechanical Time
Switches

Commercial Spring Wound Timers

These energy saving commercial timers use no electricity to operate. These timers are designed to replace any standard wall switch, single or multi-gang, and automatically limit the "ON" time of fans, lights, motors, heaters and other energy consuming loads. Time limits of 5, 15, 30 and 60 minutes and 2, 4, 6 and 12 hours are available. The "hold feature" allows the user to override the automatic shut-off function for extended use of the load as required. Rugged time-dial plate takes the abuse encountered in commercial environments. Time saving "up front" terminal connection with teeter type terminals and an easy "press-on" knob design ensure quick and easy installation.



Specifications

- **Switch Rating –**
 - **Inductive:** 20 Amp 125 VAC 50/60 Hz; 10 Amp 250 VAC 50/60 Hz; 10 Amp 277 VAC 50/60 Hz,
 - **Tungsten:** 7 Amp 125 VAC,
 - **Motor:** 1 HP 125 VAC 50/60 Hz; 2 HP 250 VAC 50/60Hz

Caution: Do not use for sunlamps, sauna, etc...

- **Colors –** Commercial "brush metal" look
- **Style –** New simulated metal finish meets NEC requirements

Products				
Model	Time Cycle	Pole	Finish	Hold
FF12HC	12 hour	SPST	Simulated brushed metal	no
FF12HHC	12 hour	SPST	Simulated brushed metal	yes
FF15MC	15 minute	SPST	Simulated brushed metal	no
FF15MH	15 minute	SPST	Simulated brushed metal	yes
FF2H	2 hour	SPST	Simulated brushed metal	no
FF30MC	30 minute	SPST	Simulated brushed metal	no

<u>FF30MH</u>	30 minute	SPST	Simulated brushed metal	yes
<u>FF312H</u>	12 hour	SPDT	Simulated brushed metal	no
<u>FF312HH</u>	12 hour	SPDT	Simulated brushed metal	yes
<u>FF32H</u>	2 hour	SPDT	Simulated brushed metal	no
<u>FF32HH</u>	2 hour	SPDT	Simulated brushed metal	yes
<u>FF34H</u>	4 hour	SPDT	Simulated brushed metal	no
<u>FF34HH</u>	4 hour	SPDT	Simulated brushed metal	yes
<u>FF36H</u>	6 hour	SPDT	Simulated brushed metal	no
<u>FF412H</u>	12 hour	DPST	Simulated brushed metal	no
<u>FF415M</u>	15 minute	DPST	Simulated brushed metal	no
<u>FF430M</u>	30 minute	DPST	Simulated brushed metal	no
<u>FF460M</u>	60 minute	DPST	Simulated brushed metal	no
<u>FF46H</u>	6 hour	DPST	Simulated brushed metal	no
<u>FF4H</u>	4 hour	SPST	Simulated brushed metal	no
<u>FF5M</u>	5 minute	SPST	Simulated brushed metal	no
<u>FF5MH</u>	5 minute	SPST	Simulated brushed metal	yes
<u>FF60MC</u>	60 minute	SPST	Simulated brushed metal	no
<u>FF60MHC</u>	60 minute	SPST	Simulated brushed metal	yes
<u>FF6H</u>	6 hour	SPST	Simulated brushed metal	no
<u>FF6HH</u>	6 hour	SPST	Simulated brushed metal	yes

Steel City®

NEW!

665 Cast Iron Floor Box



Cover opened with single-gang GFCI plate and Keystone Jack plate installed.

The new Steel City® 665 Cast Iron Floor Box provides a high capacity power and data solution for ground floor installations. This 4-gang recessed service floor box is ideal for slab-on-grade applications. Removable voltage dividers allow users to customize wiring configurations by feeding two or more adjacent compartments with a single conduit. Aesthetic covers feature a recess to accept floor covering to match the surrounding floor.

- Cast iron construction for slab-on-grade applications
- 4-Gang, recessed service for a high capacity, aesthetic floor box solution
- Removable voltage dividers between compartments allow a single conduit to feed two or more adjacent compartments
- Heavy duty nonmetallic covers with steel reinforcement plates are available in a wide variety of colors to match any décor (black, gray, brown and beige)
- Separate cord door in the cover latches firmly in the open position to prevent damage to cables
- MopTite™ covers meet UL scrubwater exclusion requirements for carpet, tile and wood
- Largest cubic inch capacity of any cast iron recessed 4-gang floor box
- Inline 1 1/4" hubs allow high capacity straight runs for communication wiring
- Custom device panels and hub sizes are available – contact technical service about these offerings



Cover shown closed.

Material: Box – Cast Iron
Cover – Polycarbonate with Steel Reinforcement Plate

Listing: UL, CSA Listed

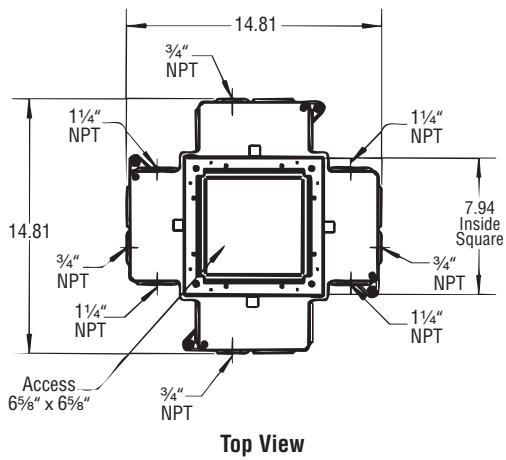

Top View

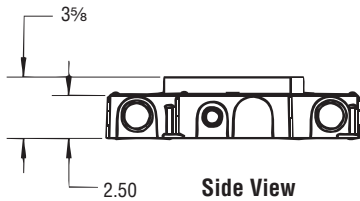

Side View

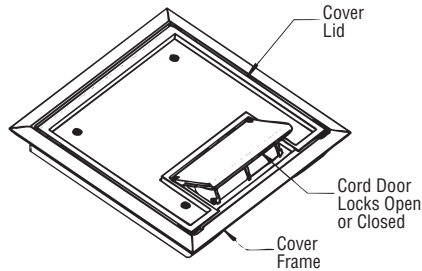
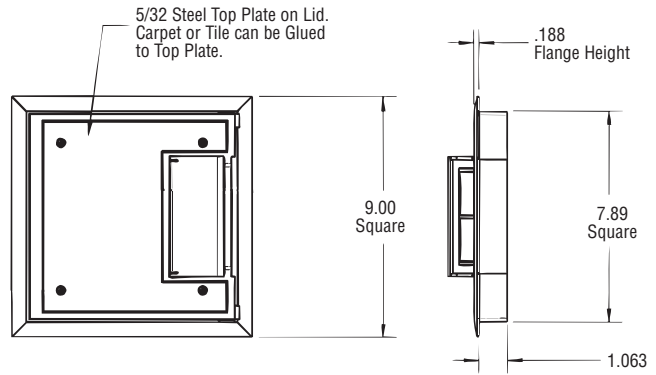

Steel City® 665 Cast Iron Floor Box

Cat. Number	Description	Std. Pkg. Qty.	UPC Number
665-CI	665 Cast Iron Floor Box	1	78599103865
665-CST-SW-BGE	665 Cover, Scrubwater Tight, Beige	4	78599103268
665-CST-SW-BLK	665 Cover, Scrubwater Tight, Black	4	78599103269
665-CST-SW-BRN	665 Cover, Scrubwater Tight, Brown	4	78599103270
665-CST-SW-GRY	665 Cover, Scrubwater Tight, Gray	4	78599103271
665-RP	665 Single Gang Duplex Plate	4	78599161862
665-GP	665 Single Gang GFCI Plate	4	78599161864
665-BP	665 Blank Plate	4	78599161863
665-6RJ	665 Data Plate - 6 Keystone Jacks	4	78599101372

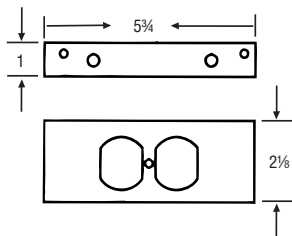

665-RP

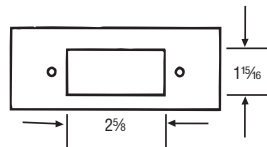

665-GP

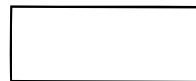

665-BP

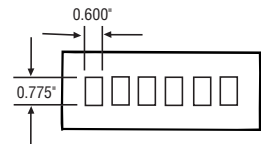

665-6RJ

Thomas & Betts

Please ask your Thomas & Betts sales representative for a complete catalog of quality Thomas & Betts electrical products or visit us at www.tnb.com. For customer service, 1-800-816-7809. For technical questions, call 1-888-862-3289.

© 2005 Thomas & Betts Corporation. All rights reserved. Printed in U.S.A. 5/05/15M GM-1626

Thomas & Betts Corporation
 Electrical Division
 8155 T&B Boulevard
 Memphis, TN 38125
 901-252-5000

Thomas & Betts Ltd.
 700 Thomas Avenue
 Iberville, Québec J2X 2M9
 450-347-5318



POWER CORD & LIGHT REELS Series 4000 and 5000

Better by Design™

Adjustable Bumper Stop

Allows any desired length of cord to be maintained outside the reel.

Corrosion-Resistant

Steel components are individually powder coated to virtually eliminate corrosion.

Reelcraft offers eight styles of outlets and lamps

- Single receptacle
- Duplex outlet box w/ GFCI (F) - 2 styles available
- R.V. plug
- Fluorescent - 2 styles available
- Incandescent - 2 styles available

Easy to Mount

Attaches to most structurally sound surfaces. Edges are curved for safety.

NOTE: Swing brackets should be used if cords are pulled at more than 45°, see page 49.



Adjustable Guide Arm

Multiple guide arm positions for versatile uses and easier field adjustment.

Enclosed Drive Spring

Drive mechanism is enclosed for protection against the environment.

Long Life Drive Spring

Declutching arbor virtually eliminates possibility of spring damage due to reverse winding of reel spool.

Structural Strength

Robotically welded heavy gauge steel frame.



MODEL NUMBER SIGNIFICANCE

This chart is for reference purposes only. Reels cannot be ordered by selecting from this chart. Please see Selection Charts on pages 40-41 or consult manufacturer for any questions about option combinations.

BUMPER ASSEMBLIES FOR CORD REELS

PART NUMBER	OUTSIDE DIA. OF CORD	CORD SPECIFICATIONS		
		AWG / mm ²	# Cond.	Type
600193	.320" - .530"	16 1.33	3	SJO
1-HR1004-A	.438" - .624"	12 3.32	3	SJO
600267	.645"	10 5.37	3	SO
1-HR1004	.625" - .749"	12 3.32	3	SO
3-HR1004-3	1.06" - 1.30"	6 8.00	3	SO

SERIES 4000 and 5000 CORD REELS

FOR REFERENCE ONLY

L 40501633

LATCH TYPE
L = LATCHING
C = CONSTANT TENSION

REEL SERIES
40 = 4000 SERIES REEL
45 = 4500 SERIES REEL
55 = 5500 SERIES REEL
57 = 5700 SERIES REEL

CSA CERTIFIED

UL LISTED

WIRE SIZE
10 = 10 GAUGE
12 = 12 GAUGE
16 = 16 GAUGE

LENGTH OF CORD
00 = W/O CORD
35 = 35 FEET
45 = 45 FEET
50 = 50 FEET

NO. OF CONDUCTORS
2 = TWO CONDUCTOR
3 = THREE CONDUCTOR

STYLE NUMBERS
NONE. OPEN END
1 = INCANDESCENT LAMP
2 = FLUORESCENT LAMP
3 = SINGLE RECEPTACLE
4 = R.V. PLUG (M)
5 = INCANDESCENT NON-SPARKING
6x = FLUORESCENT EXPLOSION PROOF
7 = DUPLEX OUTLET BOX (F) W/GFCI
8 = FLUORESCENT W/OUTLET

POWER SOURCE STYLE OPTIONS

Style #7

Metal outlet box with dual 20 AMP receptacles and GFCI protection with flip-top lid.



The GFCI Receptacle is designed to protect people from the line-to-ground shock hazards which could occur from defective power tools or appliances operating from this device or from down line outlets protected by it.

Style #4

Male rubber plug used with recreational vehicles (RV's).



Style #3A

Single 20 AMP receptacle.



Style #3B

Single 20 AMP receptacle with twist lock connector.

Style #3 Two Options

#600209 Single 15 AMP receptacle with clamp type strain relief. (Cord size - 16 AWG)



#600251

Single 15 AMP receptacle with clamp type strain relief. (Cord size - 12 AWG)



The Ground Fault Circuit Interrupter does not protect against short circuits or overloads. This is the function of the fuse or circuit breaker.

- ✓ Spring retractable with latch
- ✓ Compact for critical space requirements
- ✓ Durable abrasion and corrosion resistant baked-on powder coat finish
- ✓ Wall, ceiling or bench mount
- ✓ Engineered for industrial use
- ✓ All models supplied with cord are complete with approximately 4-5 foot pigtail and three-prong plug
- ✓ Adjustable cord stop

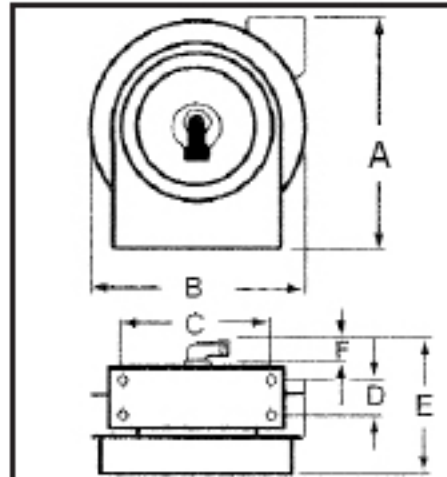

Series 4000 and 5000 models have four 5/16" diameter mounting holes. Series L5700 "E" dimension is 12 1/2".

DIMENSIONS

	L4000 L4500		L5000 L5400		L5500 L5700	
	in / mm		in / mm		in / mm	
A	13 1/4	337	14 1/2	369	17 1/2	445
B	12 5/8	321	13 3/4	350	16 1/2	419
C	8	203	9 3/4	248	9 3/4	248
D	2 1/2	64	2 1/2	64	2 1/2	64
E	9 3/8	239	12 1/2	318	12 1/2*	318
F	1 3/4	45	2 1/8	54	2 1/8	54

*Series L5700 "E" dimension is 12.5"

Made in USA

POWER CORD & CABLE REEL SELECTION CHART For indoor non-weather light applications only

MODEL	ACCESSORY	CORD SPECIFICATIONS					VOLTS *	AMPS	WEIGHT	
		AWG / mm ²	No. Cond.	Length ft / m	Type	lbs / kg				
L 4035 163 3	Single Receptacle	16 1.33	3	35 11	SJTOW	115	13	22	10	
L 4050 163 3	Single Receptacle	16 1.33	3	50 15	SJTOW	115	13	26	12	
L 4545 123 3	Single Receptacle	12 3.32	3	45 14	SJEOW	115	15	28	13	
L 5550 123 3	Single Receptacle	12 3.32	3	50 15	STOW	115	15	47	21	
L 4545 123 3A	Single Connector	12 3.32	3	45 14	SJEOW	125	20	29	14	
L 4545 123 3B	Twist Lock Connector	12 3.32	3	45 14	SJEOW	125	20	29	14	
L 5750 103 4	R.V. Plug	10 5.37	3	50 15	SO	115	35	50	23	
L 4545 123 7A	Duplex Outlet Box w/GFCI (F)	12 3.32	3	45 14	SJEOW	125	20	28	13	
L 4545 123 7	Duplex Outlet Box w/GFCI (F)	12 3.32	3	45 14	SJEOW	115	**20	29	14	
L 5550 123 7	Duplex Outlet Box w/GFCI (F)	12 3.32	3	50 15	STOW	115	**20	47	21	

*All models UL listed at 115 Volt 60 HZ single phase. Base power cord reels without cord ends are suitable for 220V.
 **Inlet plug is NEMA5-15P configuration. Plug ends not set up for 20 amp. NOTE: Swing brackets should be used if cords are pulled at more than 45°, see page 49.

POWER CORD & CABLE REEL SELECTION CHART For indoor non-weather light applications only

MODEL	ACCESSORY	REEL CAPABILITIES sold w/o cable				VOLTS *	AMPS	WEIGHT	
		AWG / mm ²	No. Cond.	Length ft / m	Type			lbs / kg	
L 4000	Reel w/o electric cord	16 1.33	3	50 15	SJO	115	13	22	10
L 4100	Reel w/o electric cord	16 1.33	4	40 12	SJO	115	13	22	10
L 4500	Reel w/o electric cord	12 3.32	3	45 14	SJO	115	25	21	9
L 5000	Reel w/o electric cord	10 5.27	3	35 11	SO	115	35	29	13
L 5400	Reel w/o electric cord	12 3.32	3	35 11	SO	115	25	25	12
L 5500	Reel w/o electric cord	12 3.32	3	50 15	STOW	115	25	34	15
L 5700	Reel w/o electric cord	10 5.27	3	50 15	SO	115	35	37	17
L 7000	Reel w/o electric cord	6 13.3	4	35 11	SO	220	50	41	19

*All models UL listed at 115 Volt 60 HZ single phase; suitable for 220 V. For indoor use only.



L 4050 163 3



L 4545 123 7



L 5700

UL LISTED
 CSA CERTIFIED



POWER CORD & LIGHT REELS Series 4000 and 5000

LIGHT STYLE OPTIONS

Fluorescent Light Style #2

- Durable shock absorbing lamp holder
- Shatter-resistant tube with switch



NEW!

Style #8

- One foot #16/3 conductor SJTOW-A yellow cord with molded NEMA 5-15P plug
- 120v-15amp receptacle is located in line on cord
- SAF-T-TIE keeps the light plugged into receptacle
- Scratch guard protects lamp cover
- For cord assembly only, order model 1 163 3 8

Style #6

- Explosion Proof 13 watt fluorescent hand lamp
 - Automatic on/off switch at reel guide arm
 - Suitable for Class 1, group C and D locations
- Note:** Reel is not explosion-proof.

Incandescent Hand Lamps

Style #5

- Rubber handle with vinyl-coated cage
- W/O switch or receptacle
- Automatic on/off switch at reel guide arm
- Complies with NEC #511-3,f., portable lighting equipment.
- Meets OSHA requirements.

Style #1

- Single receptacle tool tap
- Push-through switch
- Metal grounded guard.



UL LISTED



CSA CERTIFIED



L 4050 163 1

Note: Reel is not explosion proof

Five retractable light cord options

Illuminate your work area with incandescent, fluorescent or explosion-proof hand lamps

Made in USA

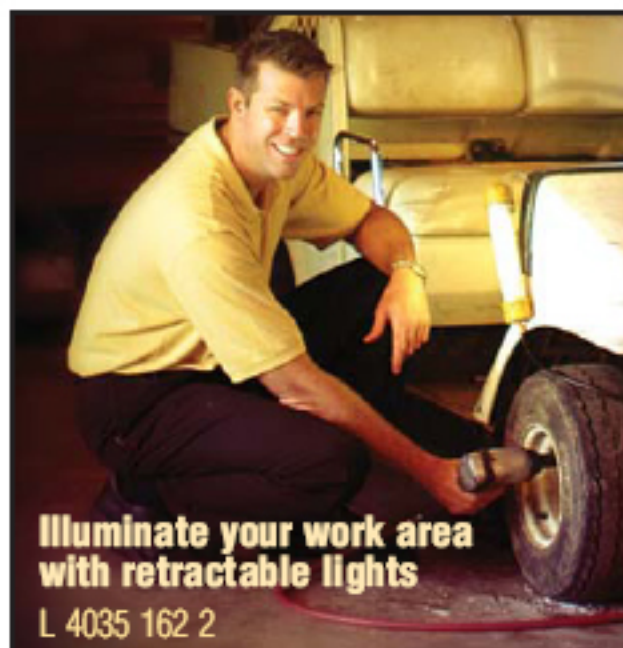

Illuminate your work area with retractable lights

L 4035 162 2

Auto-Switch Light Cord Reels

Models equipped with an automatic on/off switch incorporate a guide arm mounted switch that activates power with a pull of the cord.



L 5245 A 163 6X

LIGHT CORD REEL SELECTION CHART For indoor non-weather light applications only

MODEL	ACCESSORY	CORD SPECIFICATIONS				VOLTS*	AMPS	WEIGHT	
		AWG / mm ²	No. Cond.	Length ft / m	Type			lbs	kg
L 4035 163 1	*Incandescent	16 1.33	3	35 11	SJTOW	115	13	22	10
L 4050 163 1	*Incandescent	16 1.33	3	50 15	SJTOW	115	13	23	11
L 4035 A163 5**	*Incandescent	16 1.33	3	35 11	SJOW	115	15	25	12
L 5245 A163 6X**	Fluorescent	16 1.33	3	45 14	SEOW	115	0.3	32	15
L 4035 162 2	Fluorescent	16 1.33	2	35 11	SJTOW	115	0.3	23	11
L 4050 162 2	Fluorescent	16 1.33	2	50 15	SJTOW	115	0.3	24	11
L 4035 163 8	Fluorescent Light and Outlet	16 1.33	3	35 11	SJTO	115	10	26	11
L 4050 163 8	Fluorescent Light and Outlet	16 1.33	3	50 15	SJTO	115	10	27	12

* Incandescent bulb 75 watt maximum. All models UL listed at 115 Volt 60 HZ single phase. Base power cord reels without cord ends are suitable for 220 V. For indoor use only. See accessories page for optional mounting brackets and bases.

**Models are equipped with automatic on/off switch that activates power.

NOTE: Swing brackets should be used if cords are pulled at more than 45°, see page 49.



L 4035 162 2



reelcraftsales.com
813-241-4900



REELCRAFT

Wind Things Up With Reelcraft™