

Parking Bumpers
 Sanitary Sewer
 Splash Blocks
 Electric Handholds
 Catch Basins
 Vaults & Manholes
 Curb Inlets
 Highway Catch Basins
 Headwalls
 Highway Manholes
 Grease & Sand Traps
 Dilution - Basins
 Barrier Walls

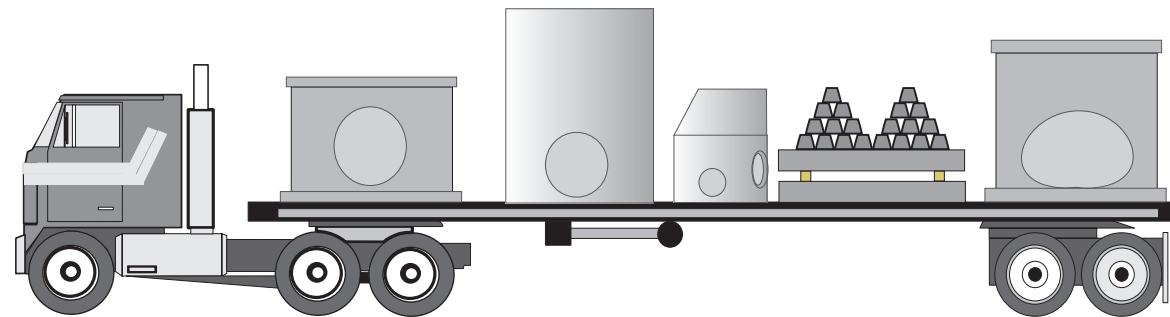

Custom Precast Products, Inc.

P.O. Drawer 242 Lumberton, MS 39455 (601) 796-8531



JOB: STENNIS SPACE CENTER / PICAYUNE, MS.

CONTR.: H.T.E.

REF. : SHOP DRAWINGS

SPECIAL NOTES !!!

1. BY APPROVING THE SUBMITTAL PACKAGE THE UNDERSIGNED HEREBY AGREES TO INDEMNIFY AND HOLD CUSTOM PRECAST PRODUCTS, INC. HARMLESS FROM ANY LIABILITY DUE TO THE FAILURE OF THE UNDERSIGNED, WHETHER BY OMISSION OR COMMISSION, TO COMPLY WITH ANY AND ALL OSHA RULES AND REGULATIONS. THE UNDERSIGNED HEREBY ACKNOWLEDGES AND AGREES IT SHALL REMAIN FULLY RESPONSIBLE FOR INSURING THAT IT HAS MET ALL OSHA STANDARDS AND THAT CUSTOM PRECAST PRODUCTS, INC. IS NOT RESPONSIBLE, IN ANY MANNER, FOR THE ACTIONS OR INACTIONS OF THE UNDERSIGNED.
2. CPPI RECOMMENDS THAT ALL SUBMITTAL DRAWINGS BE REVIEWED AND APPROVED BY THE PROJECT ENGINEER AND THE CONTRACTOR.
3. THESE APPROVED SHOP DRAWINGS SUPERCEDES ALL OTHER DRAWINGS ON THIS PROJECT.
4. C.P.P.I. DOES NOT ACCEPT BACK CHARGES. IF THERE ARE ANY PROBLEMS WITH OUR PRODUCT THE CONTRACTOR NEEDS TO NOTIFY C.P.P.I. AT 1-800-585-3112 TO HAVE THE PROBLEM FIXED. (NOTE: ALL PRODUCTS ARE BUILT STRICTLY FROM APPROVED SUBMITTAL DRAWINGS.)

NOTES

- 1- CONCRETE TO BE 4,000 PSI IN 28 DAYS
- 2- STANDARD GRAY CONCRETE WITH RIVER RUN SAND AND GRAVEL
- 3- REBAR TO BE # 5 GRADE 60
- 4- FLAT TOP WT.: 8,650 LBS.
- 5- BOTTOM WT.: 14,845 LBS.
- 6- RISER SECTION WT.: 11,400 LBS.
- 7- CABLE RACKING BY OTHERS.
- 8- MANUFACTURED IN ACCORDANCE WITH ASTM C858-07.

NO EXCEPTIONS TAKEN
 APPROVED WITH CHANGES
 RESUBMIT
 APPROVED BY:

VULCAN FOUNDRY V1600-4 RING AND COVER MARKED "COMMUNICATION" SUPPLIED AND SHIPPED LOOSE BY C.P.P.I. TO BE INSTALLED BY OTHERS.

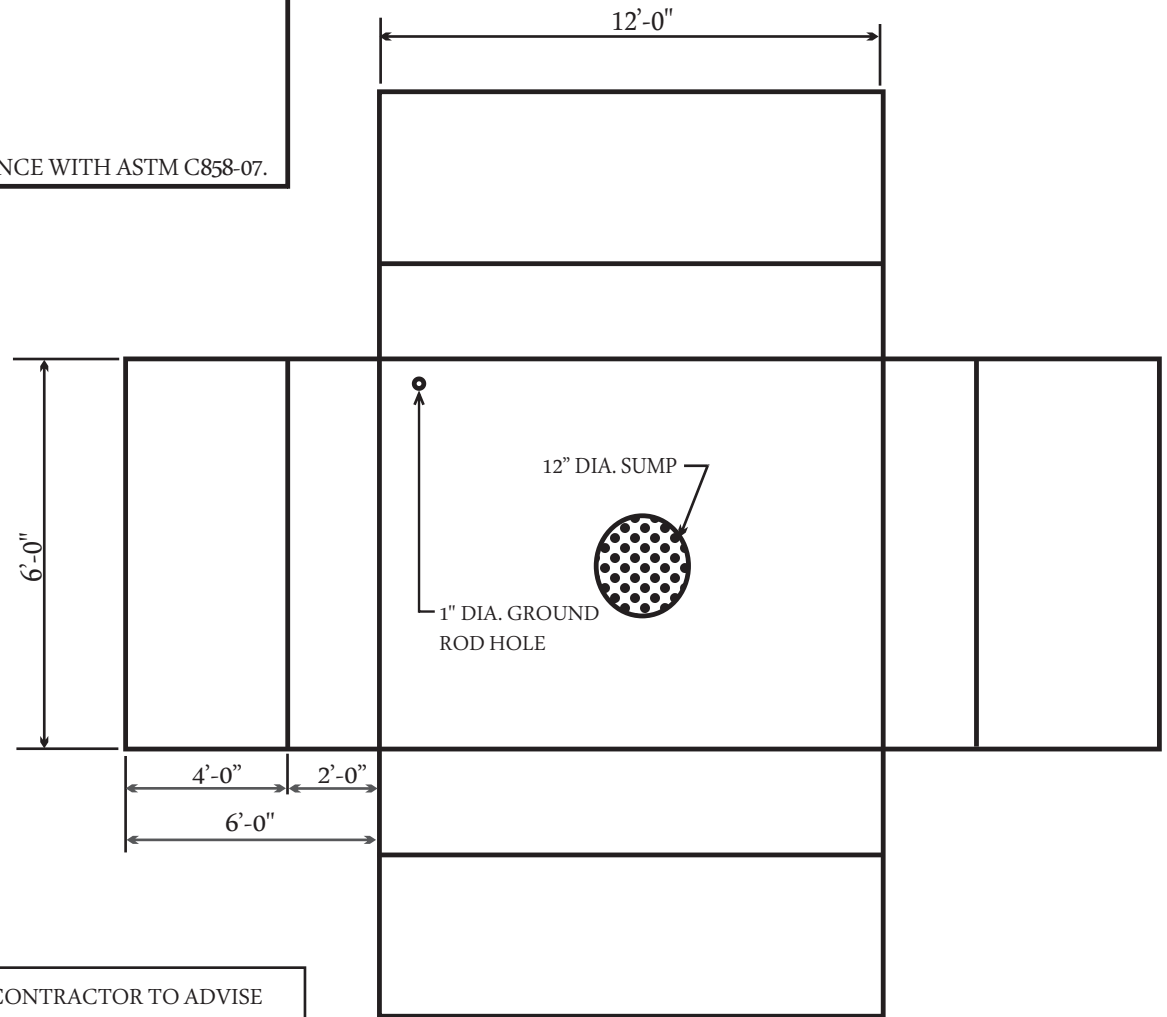
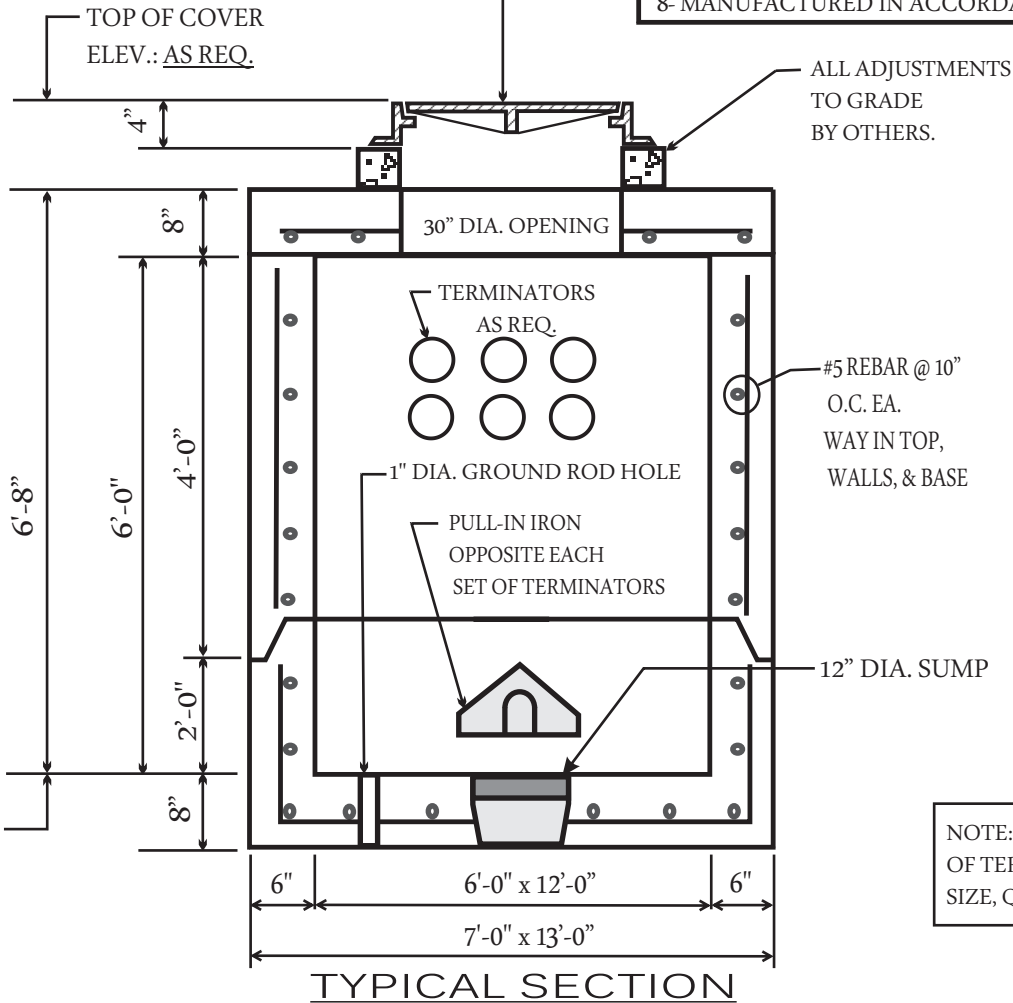

NOTE: CONTRACTOR TO ADVISE OF TERMINATOR (OR KNOCKOUT) SIZE, QUANTITIES, AND LOCATIONS.

(NO SCALE)

JOB: STENNIS SPACE CENTER / PICAYUNE, MS.
 CONTR.: H.T.E.

6'-0" X 12'-0" PRECAST COMMUNICATION MANHOLE
 (QTY: 6 REQ.)

CUSTOM PRECAST PRODUCTS INC.
 P.O. DRAWER #242 LUMBERTON, MS. 39455 (601) 796-8531

VULCAN FOUNDRY V1600-4 RING AND COVER MARKED "POWER" SUPPLIED AND SHIPPED LOOSE BY C.P.P.I. TO BE INSTALLED BY OTHERS.

NOTES

- 1- CONCRETE TO BE 4,000 PSI IN 28 DAYS.
- 2- STANDARD GRAY CONCRETE WITH RIVER RUN SAND AND GRAVEL
- 3- REBAR TO BE # 5 GRADE 60
- 4- FLAT TOP WT.: 5,840 LBS.
- 5- BOTTOM WT.: 10,830 LBS.
- 6- RISER SECTION WT.: 9,000 LBS.
- 7- CABLE RACKING BY OTHERS.
- 8- MANUFACTURED IN ACCORDANCE WITH ASTM C 858-07.

- NO EXCEPTIONS TAKEN
- APPROVED WITH CHANGES
- RESUBMIT

APPROVED BY:

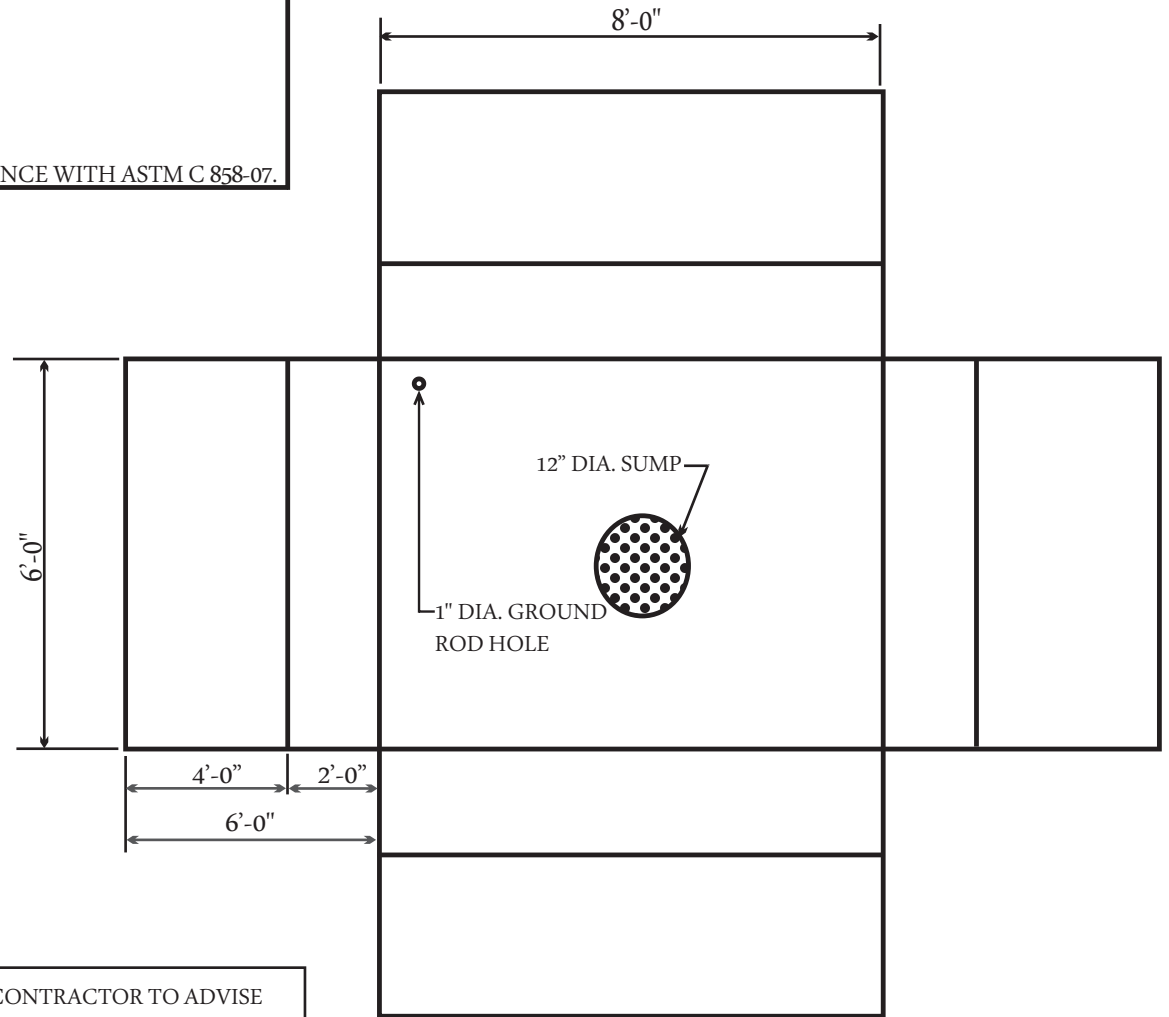
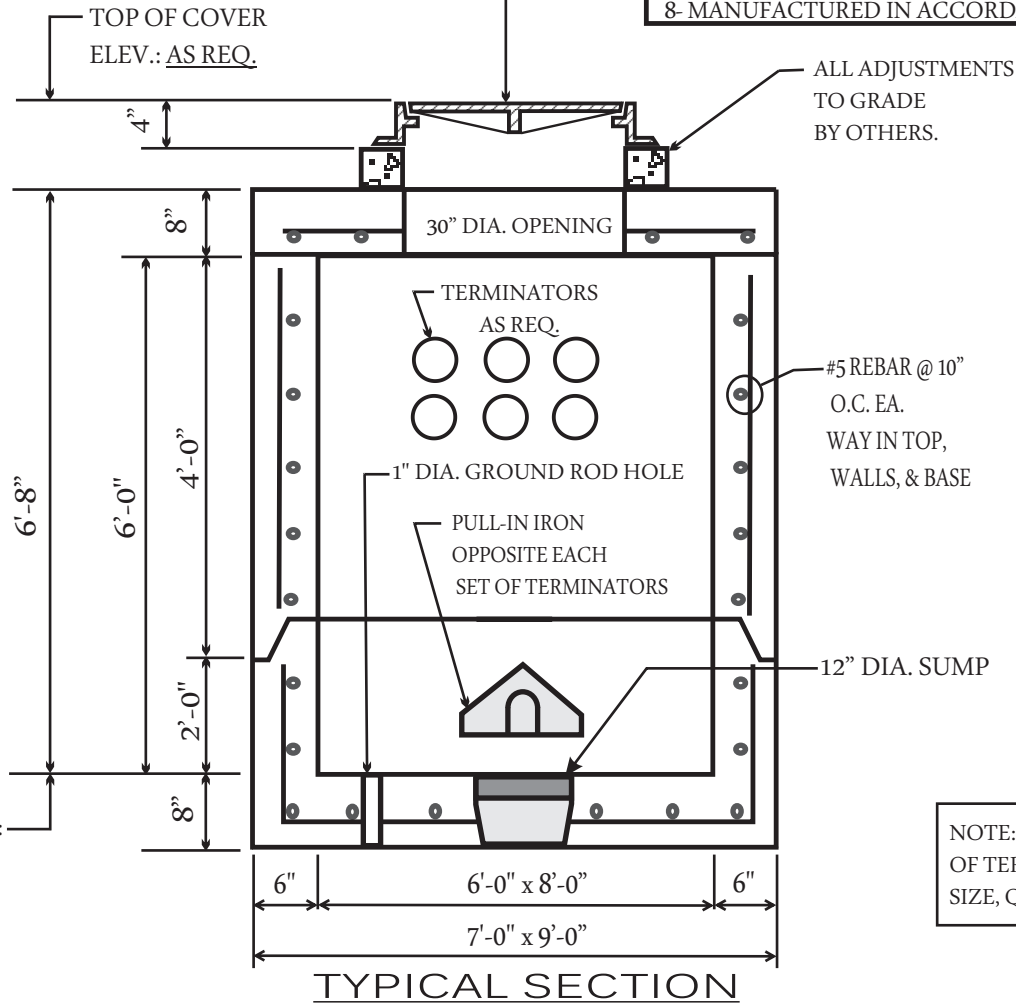

NOTE: CONTRACTOR TO ADVISE OF TERMINATOR (OR KNOCKOUT) SIZE, QUANTITIES, AND LOCATIONS.

FOLD OUT VIEW

LOOKING DOWN ON BOX WITH SIDES FOLDED OUT (FLAT TOP & RING/COVER REMOVED FOR CLARITY)

(NO SCALE)

6'-0" X 8'-0" PRECAST
POWER MANHOLE
(QTY: 1 REQ.)

JOB: STENNIS SPACE CENTER / PICAYUNE, MS.
CONTR.: H.T.E.

CUSTOM PRECAST PRODUCTS INC.

P.O. DRAWER # 242 LUMBERTON, MS. 39455 (601) 796-8531

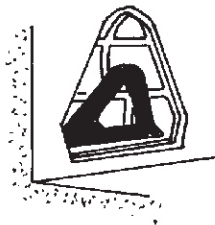
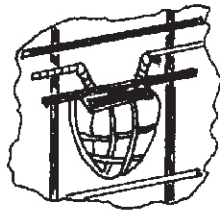

RECESSED PULLING IRON DETAIL
AS MANF. BY PENNSYLVANIA INSERT CORP.

DETAIL 'A'

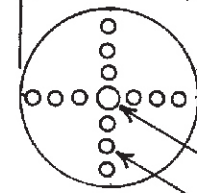
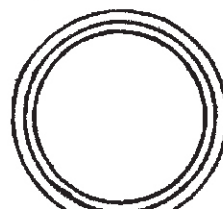
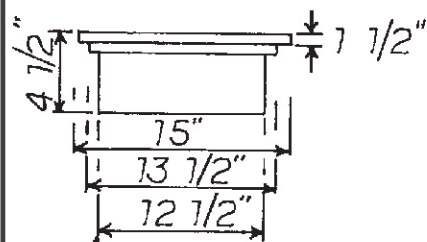

1" DIA. HOLE
5/8" DIA. HOLES

LID

PLASTIC SUMP DETAIL
AS MANF. BY PENNSYLVANIA INSERT CORP.

DETAIL 'B'

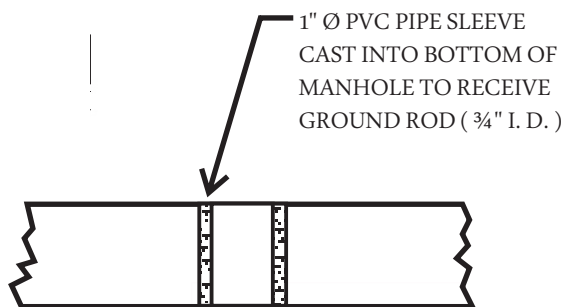

DETAIL 'E'

1. CONCRETE TO BE 4000 PSI IN 28 DAYS.
2. JOINTS TO BE SEALED WITH BIDCO C-56 JOINT SEALANT.
3. RACKING PACKAGE TO BE SUPPLIED AND INSTALLED BY CONTRACTORS.

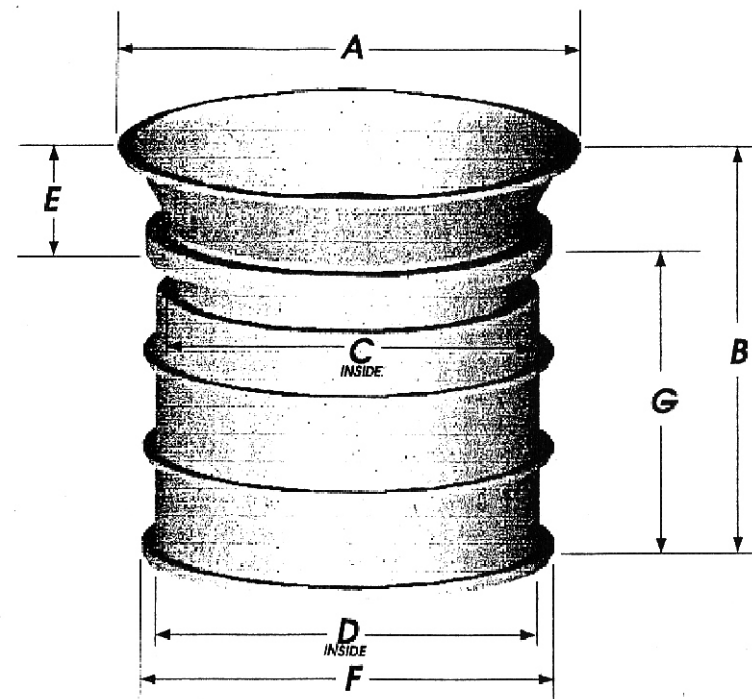

SIZE	A	B	C	D	E	F	G
2 INCH	—	—	2 1/4"	2 3/8"	—	3"	3 1/2"
4.50 INCH	5 1/4"	4 3/8"	4 3/8"	4 1/2"	11/4"	4 15/16"	3 3/8"
4.35 INCH	5 1/4"	4 3/8"	4 1/4"	4 3/8"	11/4"	4 13/16"	3 3/8"
4 INCH STEP DOWN	5 1/4"	4 3/8"	4 1/4"	4 1/2"	11/4"	4 15/16"	3 3/8"
5 INCH	6 5/8"	4 3/8"	5 1/2"	5 5/8"	11/4"	6 1/4"	3 3/8"
6 INCH	7 5/8"	4 3/8"	6 1/2"	6 5/8"	11/4"	7 1/4"	3 3/8"

SIZE	GLUE SURFACE
2 INCH	2 3/4 INCH
4.50 INCH	2 5/8 INCH
4.35 INCH	2 5/8 INCH
4 INCH STEP DOWN	1 5/16 INCH EACH STEP
5 INCH	2 3/4 INCH
6 INCH	2 3/4 INCH

JOB: STENNIS SPACE CENTER / PICAYUNE, MS.
CONTR.: H.T.E.

ELECTRICAL MANHOLE
DETAIL SHEET

CUSTOM PRECAST PRODUCTS INC.
P.O. DRAWER #242 LUMBERTON, MS. 39455 (601) 796-8531

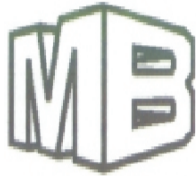

HOOK-LIFT UTILITY ANCHOR

ITEM NUMBER	DESCRIPTION	FINISH	UNIT WEIGHT (LBS)	TYPE	QTY.	WEIGHT (LBS)
79U55	UTILITY ANCHOR 5 1/2" SLAB	MILL	1.25	DRUM	550	688

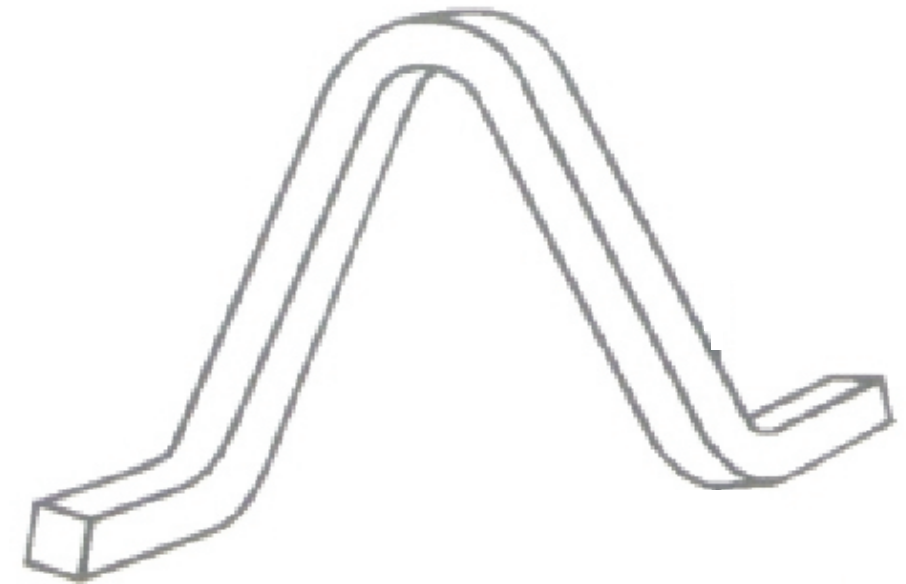
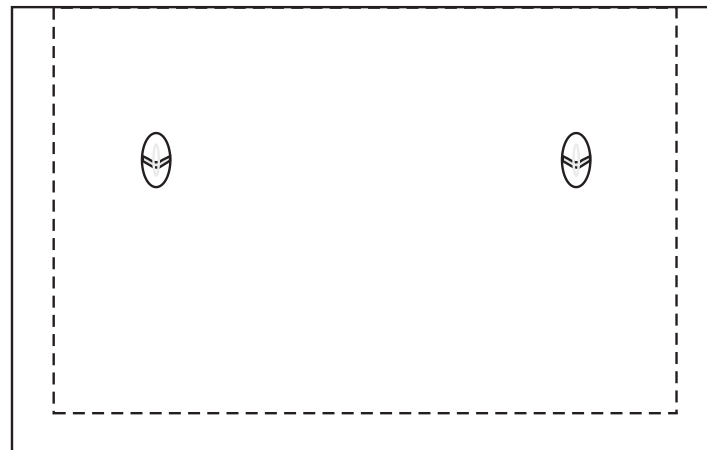

JOB: STENNIS SPACE CENTER / PICAYUNE, MS.
CONTR.: H.T.E.

HOOK LIFT UTILITY
ANCHOR DETAIL

CUSTOM PRECAST PRODUCTS INC.
P.O. DRAWER #242 LUMBERTON, MS. 39455 (601) 796-8531

**BIDCO C-56 PRE-FORMED
BUTYL MASTIC JOINT SEALANT**

PRODUCT FEATURES:

1. AVAILABLE IN STRIP OR COIL FORM
2. NEW, CRUSH PROOF PACKAGE
3. NON-STICK, NON-TEAR PLASTIC BACKING

CHEMICAL COMPOSITION	SPECIFICATION	REQUIREMENTS	C-56
CONTENT OF HYDROCARBON - % BY WT.	ASTM D4-86	50-70	56.0
INERT MINERAL FILLER - % BY WT.	AASHTO T III	30-50	44.0
VOLATILE MATTER - % BY WT.	ASTM D-6	2.0 MAX	BELOW 1

CHEMICAL RESISTANCE (TOTAL IMMERSION - 30 DAYS)

- 5% SULFURIC ACID - NO VISIBLE DETERIORATION
- 5% HYDROCHLORIC ACID - NO VISIBLE DETERIORATION
- 5% POTASSIUM HYDROXIDE - NO VISIBLE DETERIORATION
- SATURATED HYDROGEN SULFIDE SOLUTION - NO VISIBLE DETERIORATION

PHYSICAL PROPERTIES:

- SPECIFIC GRAVITY - 77°F ASTM D-71 1.2-1.35 1.27
- DUCTILITY - 77°F ASTM D-113 5.0 MIN. 10.00
- SOFTENING POINT - °F ASTM D-36 320 MIN 380
- PENETRATION - 77°F ASTM D-217 50 - 120 85
- ACCELERATED AGING (MECHANICAL OVEN 4 HOURS @ 212°F)
 MAINTAINED 99+% SOLIDS (FLEXIBILITY NOT EFFECTED)
- ELONGATION INITIAL 77°F - 330% MIN
 TWO WEEKS - TOTAL WATER IMMERSION - 330% MIN
- FLOW RESISTANCE (1" WIDE OVERHEAD JOINT EXPOSED TO 135°F FOR 7 DAYS - NO FLOW
- STORAGE LIFE - INDEFINITE
- APPLICATION TEMPERATURE RANGE - 10 TO 125°F
- SERVICE TEMPERATURE RANGE - NEGATIVE 20 TO 200°F

C-56 BUTYL JOINT SEALANT IS DESIGNED TO FULLY COMPLY WITH CURRENT ASTM STANDARDS AND SPECIFICATIONS AS REQUIRED BY FEDERAL, STATE, AND LOCAL AGENCIES FOR USE BY THE PRECAST CONCRETE INDUSTRY AND CONTRACTORS.

C-56 REMAINS FLEXIBLE AND FORMS A PERMANENT BOND TO A WIDE VARIETY OF SUBSTRATES INCLUDING CONCRETE, METALS, AND PLASTICS. ADHESION AND COHESION AT THE TIME OF INSTALLATION ARE EXCELLENT, AND ACTUALLY IMPROVE AFTER THE JOINT HAS BEEN FORMED AND PLACED IN SERVICE. THIS SEALANT IS DESIGNED NOT TO SHRINK, OXIDIZE OR HARDEN AND HAS EXCELLENT RESISTANCE TO TEMPERATURE EXTREMES, ACID AND ALKALINE ENVIRONMENTS.

PRIMARY APPLICATIONS:

- CONCRETE PIPE BOX CULVERTS
- UTILITY VAULTS BURIAL VAULTS
- SEPTIC TANKS WET WELLS
- SANITARY & STORM SEWER MANHOLES
- CONCRETE WALL PANEL SYSTEMS

CONFORMS TO AASHTO M-198B
SS-S210A - ASTM C 900

**AVAILABLE SIZE:
BIDCO C-56**

JOINT STRIPS SIZE X LENGTH	STRIP PER CONTAINER
1 ¼" X 42"	28

NPC
ST. JOE DR. & LEWIS ST.
PARK HILLS, MO 63601
TELEPHONE: 1-800-442-0141
FAX: 573-431-1035

JOB: STENNIS SPACE CENTER / PICAYUNE, MS.
CONTR.: H.T.E.

BIDCO C-56 BUTYL
MASTIC JOINT SEALANT

CUSTOM PRECAST PRODUCTS INC.
P.O. DRAWER #242 LUMBERTON, MS. 39455 (601) 796-8531

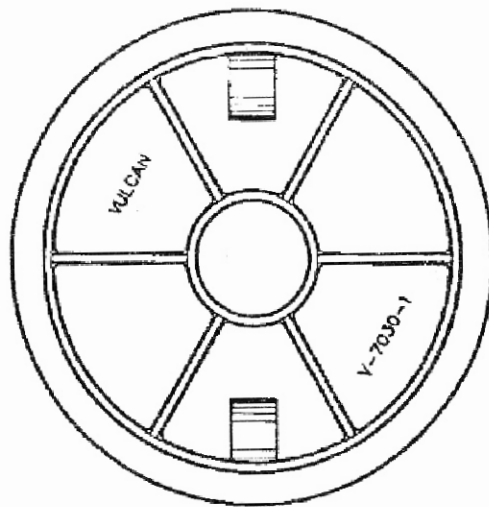

COVER BACK

COVER MARKED AS REQUIRED

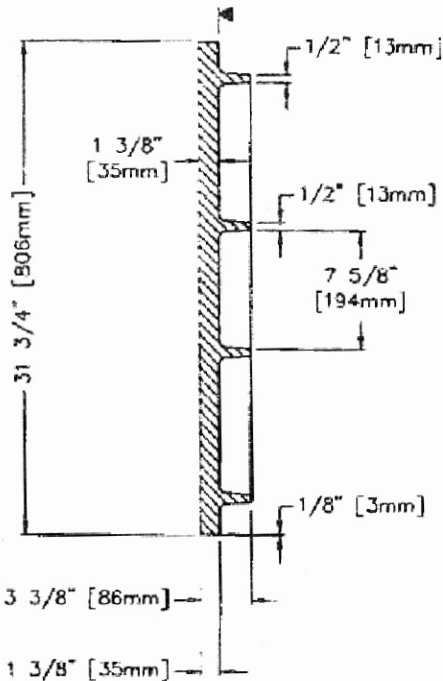

COVER SECTION

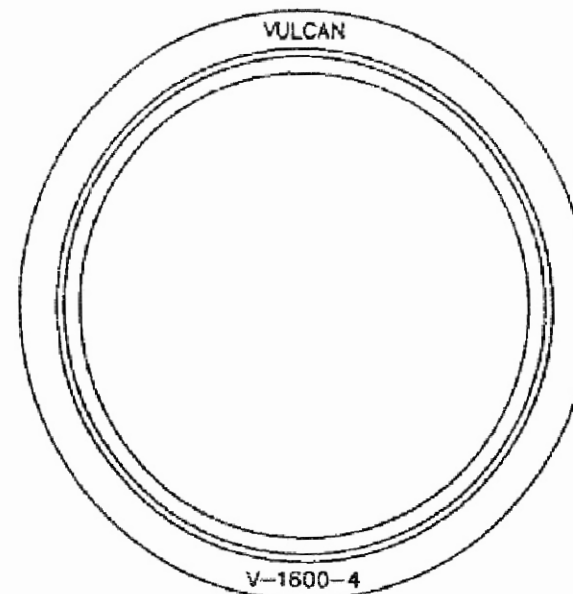

REVERSIBLE RING TOP VIEW

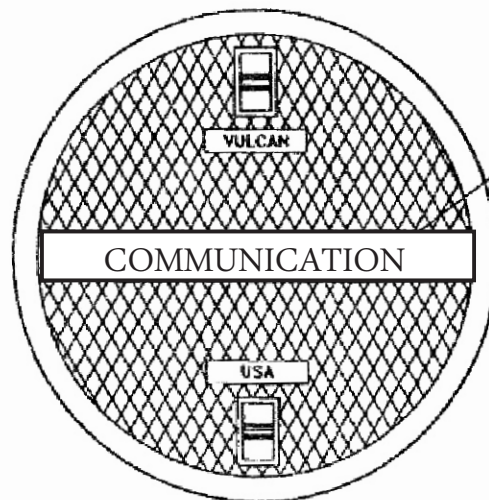

COVER FACE

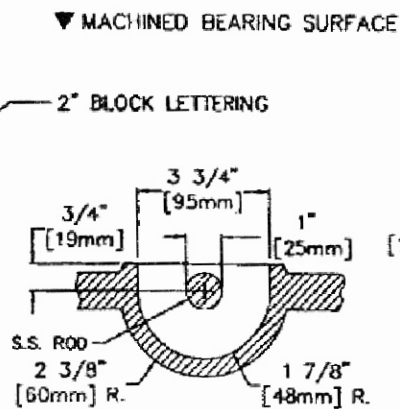

(2) TYPE 4 STAINLESS STEEL PICKBARS

PICKBAR DETAIL

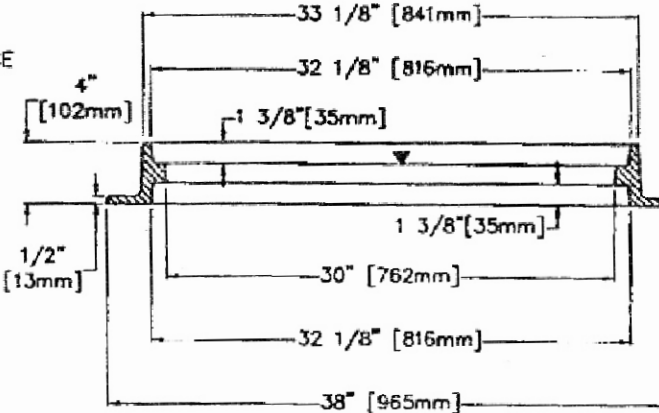

REVERSIBLE RING SECTION

NOTE: FOR TOP FLANGE ORDER NUMBER V-1800-4,
FOR BOTTOM FLANGE ORDER NUMBER V-1600-4.

Vulcan Foundry Corp.

POST OFFICE BOX 905
DENHAM SPRINGS, LA 70727
WATS No. 1-800-MANHOLE
LOCAL No. 1-225-665-6151
FAX No. 1-225-665-4306

DRAWN BY: OHV DATE:10/12/98
REVISION: UPDATED

LOAD RATING
HEAVY DUTY

MATERIAL SPECIFICATION
ASTM A48 CLASS 30

OPEN AREA - sq.in [sq.cm]
N/A

ESTIMATED WEIGHT - lbs.[kg]

COVER 310 [1451kg]
RING 145 [66kg]

TOTAL 455 [207kg]

PATTERN BREAKDOWN

V-7030-1 COVER
V-1600-4 RING

CATALOG NUMBER

V-1600-4

PRODUCT NUMBER

41600466

V-1600-4

JOB: STENNIS SPACE CENTER / PICAYUNE, MS.
CONTR.: H.T.E.

V-1600-4 RING AND
COVER DETAIL

CUSTOM PRECAST PRODUCTS INC.
P.O. DRAWER #242 LUMBERTON, MS. 39455 (601) 796-8531

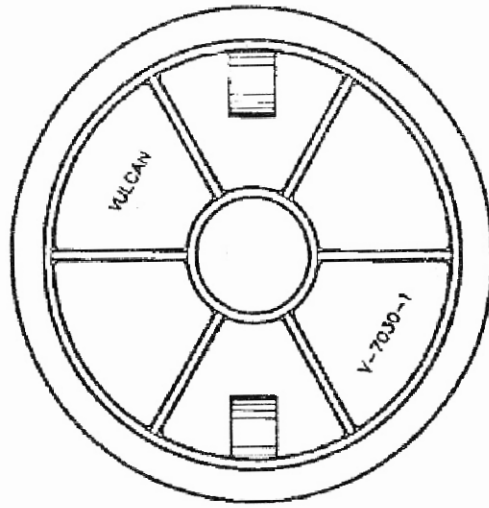

COVER BACK

COVER MARKED AS REQUIRED

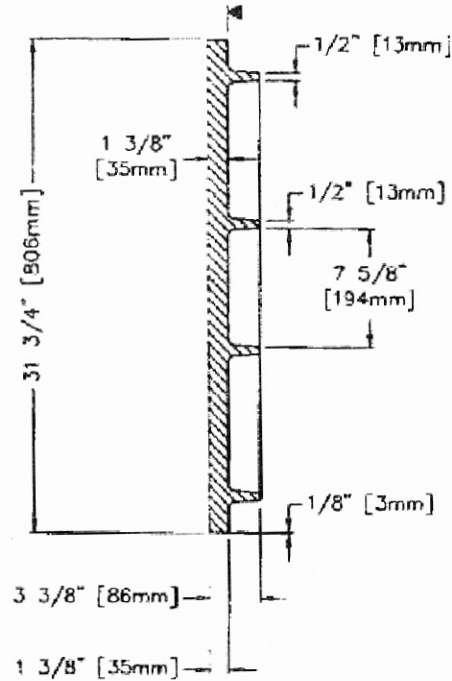

COVER SECTION

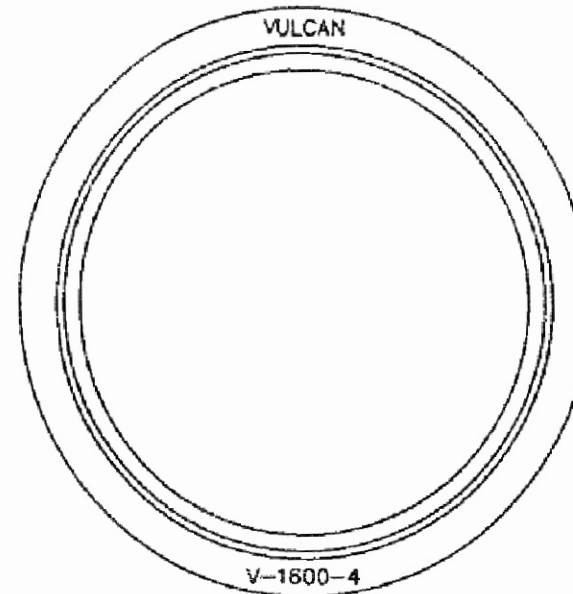

REVERSIBLE RING TOP VIEW

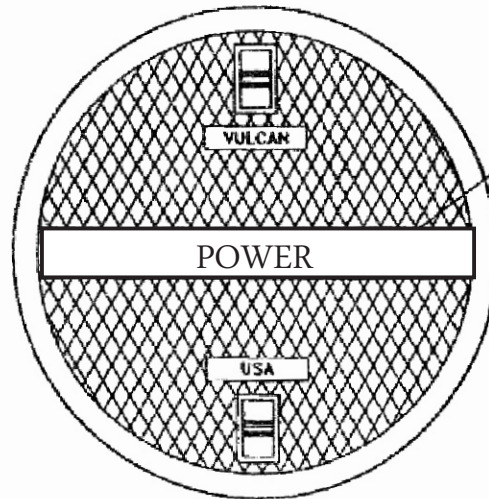

COVER FACE

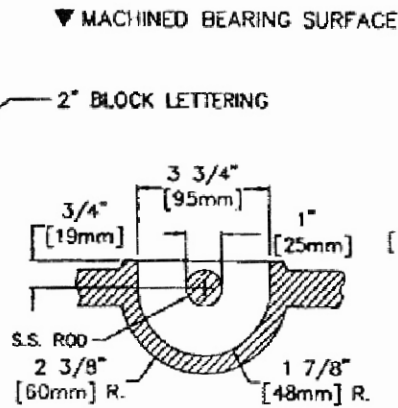

(2) TYPE 4 STAINLESS STEEL PICKBARS

PICKBAR DETAIL

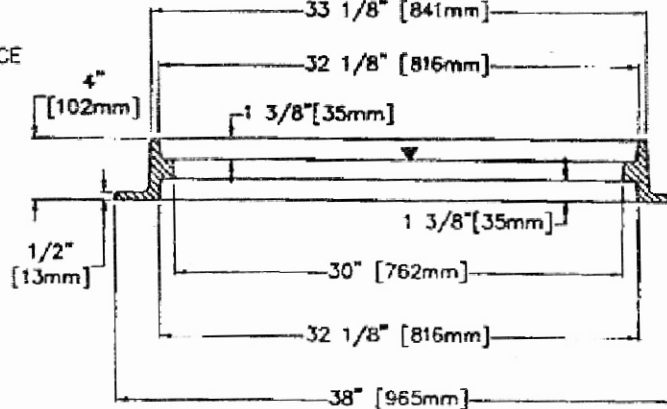

REVERSIBLE RING SECTION

NOTE: FOR TOP FLANGE ORDER NUMBER V-1800-4,
FOR BOTTOM FLANGE ORDER NUMBER V-1600-4.

Vulcan Foundry Corp.
 POST OFFICE BOX 905
 DENHAM SPRINGS, LA 70727
 WATS No. 1-800-MAHOLE
 LOCAL No. 1-225-665-6151
 FAX No. 1-225-665-4306
 DRAWN BY: OHV DATE:10/12/98
 REVISION: UPDATED

LOAD RATING
 HEAVY DUTY
 MATERIAL SPECIFICATION
 ASTM A48 CLASS 30

OPEN AREA - sq.in [sq.cm]
 N/A

ESTIMATED WEIGHT - lbs.[kg]
 COVER 310 [1451kg]
 RING 145 [66kg]
 TOTAL 455 [207kg]

PATTERN BREAKDOWN
 V-7030-1 COVER
 V-1600-4 RING

CATALOG NUMBER
V-1600-4
 PRODUCT NUMBER
41600466

V-1600-4

JOB: STENNIS SPACE CENTER / PICAYUNE, MS.
 CONTR.: H.T.E.

V-1600-4 RING AND
 COVER DETAIL

CUSTOM PRECAST PRODUCTS INC.
 P.O. DRAWER #242 LUMBERTON, MS. 39455 (601) 796-8531

SPECIFICATIONS/DATA

11" x 18" PC Style (Stackable) Assembly

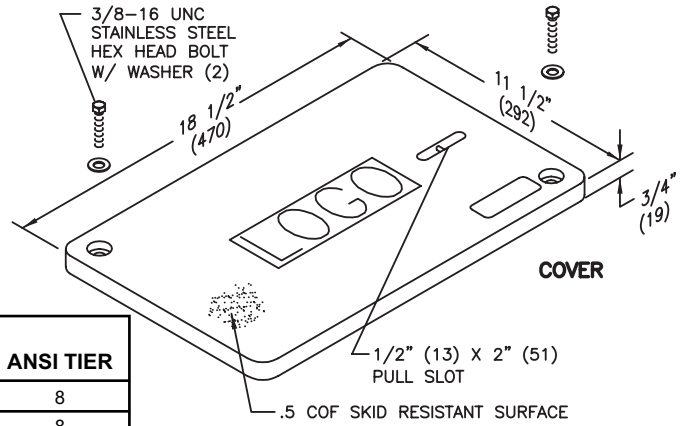

Covers (Blank unless logo is specified)

DESCRIPTION	PART NO.	WEIGHT #	DESIGN/TEST LOAD #	ANSI TIER
W/2 Bolts	PC1118CA00	13 (5.9 kg)	8,000 / 12,000	8
Gasketed w/4 Bolts	PC1118CG00	13 (5.9 kg)	8,000 / 12,000	8
No Bolts	PC1118WA00	13 (5.9 kg)	8,000 / 12,000	8
Heavy Duty w/2 Bolts	PC1118HA00	13 (5.9 kg)	15,000 / 22,500	15
Gasketed Heavy Duty w/4 Bolts	PC1118HG00	13 (5.9 kg)	15,000 / 22,500	15

• Gasketed covers and bolt grommets must be used with a gasketed box. Gaskets reduce the inflow of fluids but do not make the enclosure water tight.

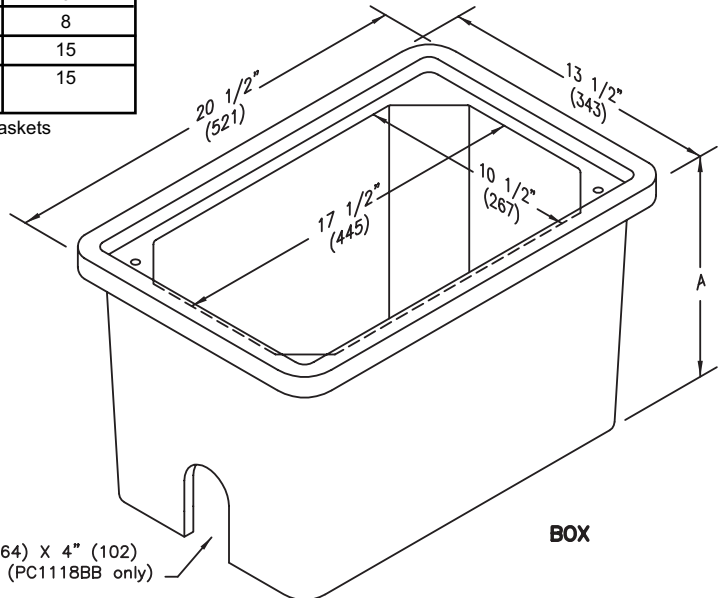
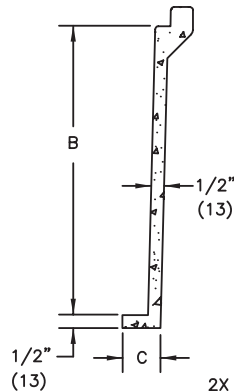

ENCLOSURE DRAWINGS

Boxes (Stackable with self-aligning, replaceable EZ-Nut)

DESCRIPTION	PART NO.	WEIGHT #	DIMENSION A	DIMENSION B	DIMENSION C	DESIGN/TEST LOAD #	ANSI TIER
Open Bottom	PC1118BA12	37 (16.8 kg)	12" (304.8 mm)	11 1/4" (286 mm)	N/A	15,000 / 22,500	15
	PC1118BA18	53 (24.0 kg)	18" (457 mm)	17 1/4" (438 mm)	N/A	15,000 / 22,500	15
Open Bottom w/ Gasket	PC1118BG12	37 (16.8 kg)	12" (304.8 mm)	11 1/4" (286 mm)	N/A	15,000 / 22,500	15
	PC1118BG18	53 (24.0 kg)	18" (457 mm)	17 1/4" (438 mm)	N/A	15,000 / 22,500	15
Open Bottom w/ 2 Mouseholes	PC1118BB12	36 (16.3 kg)	12" (304.8 mm)	11 1/4" (286 mm)	N/A	15,000 / 22,500	15
	PC1118BB18	52 (23.6 kg)	18" (457 mm)	17 1/4" (438 mm)	N/A	15,000 / 22,500	15
Solid Bottom	PC1118DA12	45 (20.4 kg)	12 1/2" (317.5 mm)	11 1/4" (286 mm)	N/A	15,000 / 22,500	15
	PC1118DA18	60 (27.2 kg)	18 1/2" (470 mm)	17 1/4" (438 mm)	N/A	15,000 / 22,500	15
Solid Bottom w/ Gasket	PC1118DG12	45 (20.4 kg)	12 1/2" (317.5 mm)	11 1/4" (286 mm)	N/A	15,000 / 22,500	15
	PC1118DG18	60 (27.2 kg)	18 1/2" (470 mm)	17 1/4" (438 mm)	N/A	15,000 / 22,500	15
Footed Box	PC1118JA12	37 (16.8 kg)	12 1/2" (317.5 mm)	11 1/4" (286 mm)	1 1/2" (38 mm)	15,000 / 22,500	15
	PC1118JA18	56 (25.4 kg)	18 1/2" (470 mm)	17 1/4" (438 mm)	1 1/2" (38 mm)	15,000 / 22,500	15

Dimensions & weights in parentheses are metric equivalent.