

Design No. G714

February 17, 2009

1 HR. RATING

Restrained Assembly Ratings 1, 1-1/2, 2 or 3 Hr.
Unrestrained Assembly Ratings 1, 1-1/2, 2 or 3 Hr. (See Item 2 and 5)
Unrestrained Beam Ratings 1, 1-1/2, 2 or 3 Hr. (See Items 2 and 5)

1. Normal Weight or Lightweight Concrete -- Normal weight concrete: carbonate or siliceous aggregate concrete, 147 to 150 pcf unit weight, 3500 psi compressive strength, vibrated. Lightweight concrete: expanded shale, clay, or slate aggregate by rotary-kiln method, 110 to 118 pcf unit weight, 3000 psi compressive strength, vibrated. 2 oz. air entrainment per bag of cement. For 1-1/2 and 2 h assembly ratings, the 2-3/4 in. concrete topping thickness may be reduced to 2-1/2 in. when noncomposite joists are used. The Unrestrained Assembly Rating depends on the type of concrete aggregate and joist spacing as shown below.

Unrestrained Assembly Rating		
Max Joist Spacing	3 ft, 6 in.	Joist Spacing Greater Than 3 ft, 6 in. O.C.
Lightweight Aggregate	1-1/2 h	1-1/2 h
Normal Weight Aggregate	2 h	1-1/2 h

2. Welded Wire Fabric -- 6x6-8/8 SWG.

3. Steel Floor and Form Units -- No. 28 MSG golv corrugated sheet steel min. 2-1/2 in. pitch and 1/2 in. depth of corrugations. Units welded to each joist, 36 welds per 100 sq ft of form units, with at least one weld at each joint.

4. Steel Joists -- Min. 16K6 or heavier with min. 3/4 in. diam or large cross sectional area for web members with horizontal bridging, Item 7. As an alternate, any LH Series steel joists spanning no greater than 60 ft may be used. For spans greater than 60 ft, LH Series joists may be used provided that the deflection under their published total load shall not be greater than 1/277 of the joist span.

4A. Steel Joist -- As an alternate to Item 4, composite or noncomposite welded or bolted to end supports. May be uncoated or provided with a shop coat of paint. Designed per S.J.I. specifications for a max design stress of 30,000 psi. Top chords shall consist of two angles measuring 1-1/2 by 1-1/2 by 0.156 in. thick. Bottom chord shall consist of two round bars measuring 0.675 in. in. diam. or two angles measuring 1 by 1.0125 in. thick. The second web member at each end shall consist of a 0.554 in. diam round bar. Primary web members, including the end web members, shall consist of 0.774 in. diam round bars. All remaining non-primary web members shall consist of 0.5 in. diam round bars. Horizontal bridging (Item 7) per S.J.I. specifications is required when noncomposite joists are used.

4B. Composite Joists -- (Not Shown) -- As an alternate to Item 4 and 4A, steel joists designed for full composite action with the concrete slab. Min overall depth 13 in. Min area of joist members shall be 0.708 sq in. for top and bottom chord angles and 0.442 sq in. for web. Designated in accordance with SJI Specifications for K-Series joists as revised in November 15, 1989.

4C. Structural Steel Members* -- (Not Shown) As an alternate to 4, 4A and 4B-(not shown) -- Composite joists with top chord embedded in concrete slab. Welded to end supports. Min area of joist members shall be 0.708 sq in. for top and bottom chord angles and 0.442 sq in. for web.

VESSCOM STRUCTURAL SYSTEMS, INC. -- Type V

4D. Steel Joists -- As an alternate to Items 4, 4A, 4B or 4C -- may be either uncoated or provided with a shop coat of paint. Composite or noncomposite. Welded or bolted to end supports. Designed per S.J.I. specifications for a max design stress of 30 ksi. The top chords shall consist of two angles measuring 1-1/4 by 1-1/4 by 0.127 in. thick. Bottom chords shall consist of two round bars measuring 0.566 in. in. diam. or two angles measuring 1 by 1.0125 in. thick. Bearing plates shall consist of two angles measuring 1-1/2 by 2 by 0.188 in. thick and 5-1/16 in. long. Web members shall consist of 0.565 in. diam bars. The min depth and weight shall be 8 in. and 4.9 lb/ft, respectively.

4E. Steel Beam -- As an alternate to steel joists (Items 4-4D), W8x28 min size.

5. Spray-Applied Fire Resistive Materials* -- Applied by mixing with water and spraying in one or more coats to the thicknesses shown below, to steel surfaces which are clean and free of dirt, loose scale and oil. Use of Type PPKC Pre-coat is required on steel floor and form units. Type PPKC Pre-coat shall be applied to cover approx. 70 percent of the surface. Thickness of Type PPKC Pre-coat is included in the total thickness of the protection material. Min average and min individual density of 17.5 and 16 pcf, respectively, for Type PC3C. Min average and min individual density of 22 and 19 pcf, respectively, for Type PC4C. For method of density determination, see Design Information Section, Sprayed Material.

Restrainted Assembly Rating	Unrestrained Assembly Rating	Min Thickness In., Deck	Min Thickness In., Joist (Item 4, 4B, 4C)	Min Thickness In., Joist (Item 4A)	Min Thickness In., Joist (Item 4D) Normal Weight Concrete	Min Thickness In., Joist (Item 4D) Light Weight Concrete	Min Thickness In., Beam (Item E)
1	1	1/2	1-1/2	9/16+	1+	1-1/8+	5/16
1-1/2	1	1/2	1-1/2	1	1-9/16	1-3/4	5/16
2	1	1/2	1-1/2	1-3/8	2-1/16	2-1/4	5/16
2	1-1/2	1/2	1-1/2	1-3/8	2-1/16	2-1/4	1/2
2	2	1/2	1-1/2	1-3/8	2-1/16	2-1/4	11/16
3	2	1/2	1-1/2	2-1/4	-	-	11/16
3	3	1	2-1/4	2-1/4	-	-	1-11/16

CAFCO INTERNATIONAL, L.L.C. -- Types PC3C, PC4C and PPKC.
CAFCO INTERNATIONAL, DIV OF PROMAT UK LTD -- TYPES PC3C, PC4C AND PPKC.
FLAMTECHNOC CO LTD -- Type PC3C.
NEWKEM PRODUCTS CORP -- Type PC3C.

+ When bottom chords consist of 1 by 1 by 0.125 in. thick steel angles, the thickness of spray-applied fire resistive material shall be increased by 1/4 in. on the bottom chord only.

6. Metal Lath -- (Optional) -- Metal lath may be used to facilitate the spray application of spray-applied resistive material on steel bar joists and trusses. The diamond mesh, 3/8 in. expanded steel lath, 1.7 to 3.4 lb/sq yd is secured to one side of each steel joist with No. 18 SWG golv steel wire at joist web and bottom chord members, spaced 15 in. O.C. max. When used, the metal lath is to be fully covered with spray-applied resistive material with no min thickness requirements.

6A. Nonmetallic fabric mesh -- (Optional, Not Shown) -- As an alternate to metal lath, glass fiber mesh, weighing approx. 2.5 oz/sq yd, polypropylene fabric mesh, weighing approx. 1.25 oz/sq yd or equivalent, may be used to facilitate the spray application. The mesh is secured to one side of each joist web member. The method of attaching the mesh must be sufficient to hold the mesh and the spray-applied resistive material in place during application until it has cured. An acceptable method to attach the mesh is by embedding the mesh in min 1/4 in. long beads of hot melted glue. The beads of glue shall be spaced a max of 12 in. O.C. along the top chord of the bar joist. Another method to secure the mesh is by 1-1/4 in. long by 1/2 in. wide hairpin clips formed from No. 18 SWG or heavier steel wire.

7. Horizontal Bridging -- (Not Shown) -- Min 1-1/4x1-1/4x1/8 in. thick steel angles for use with noncomposite joists (Item 4 and 4A). Number and spacing per Steel Joist Institute specifications. Welded to top and bottom chord of the joists. Min thickness of spray-applied resistive material on bridging angles is min thickness on steel joist.

*Bearing the UL Classification Mark

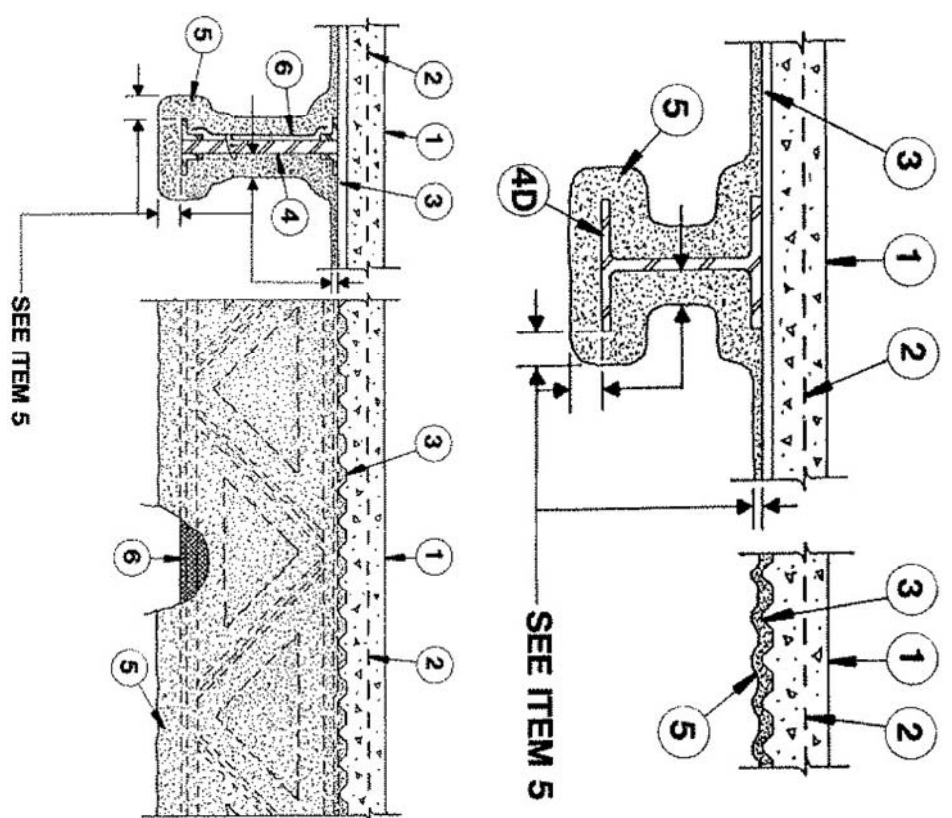

1

2

3

4

5

6

7

8

9

10

11

12

13

14

15

16

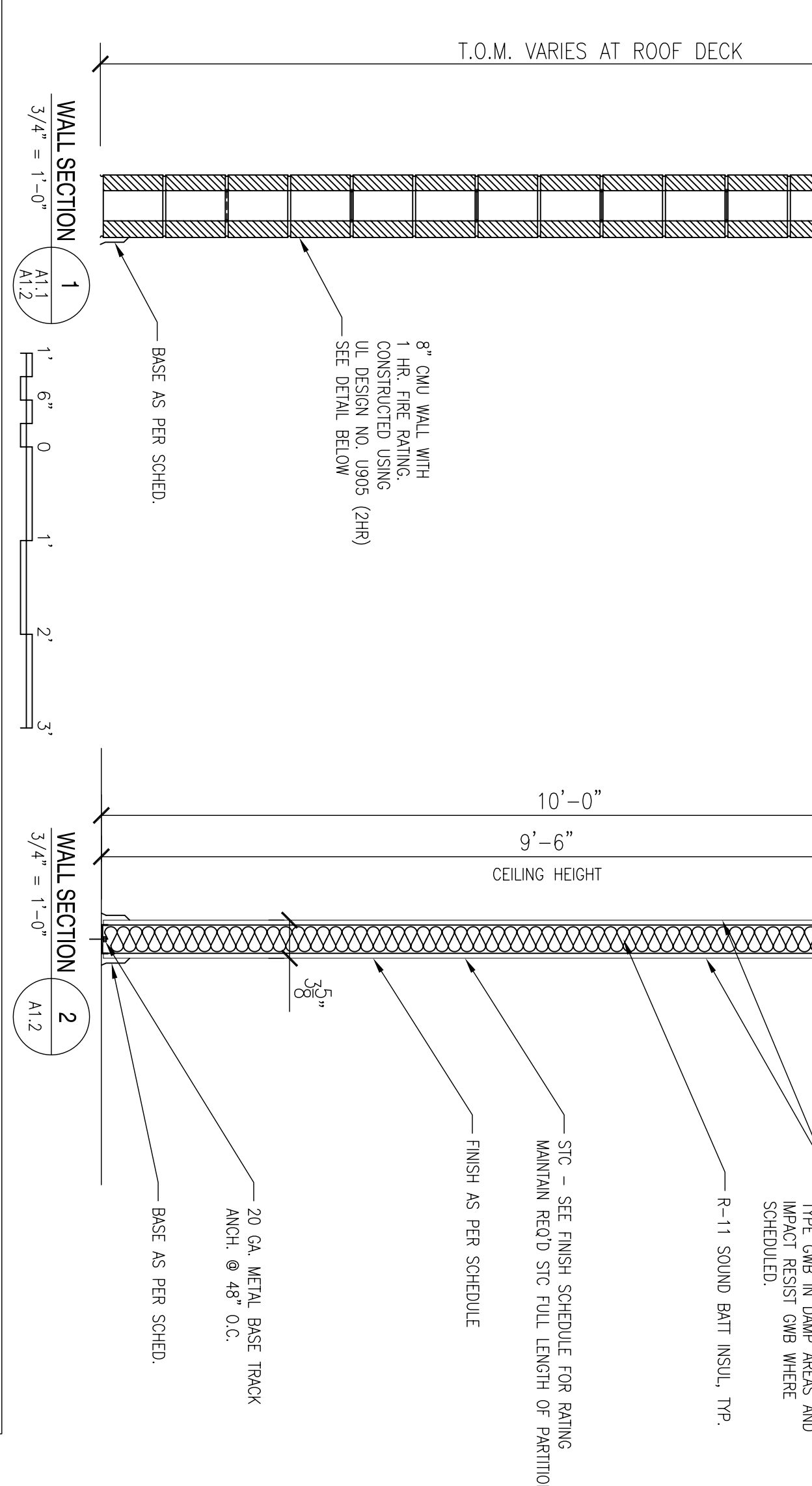
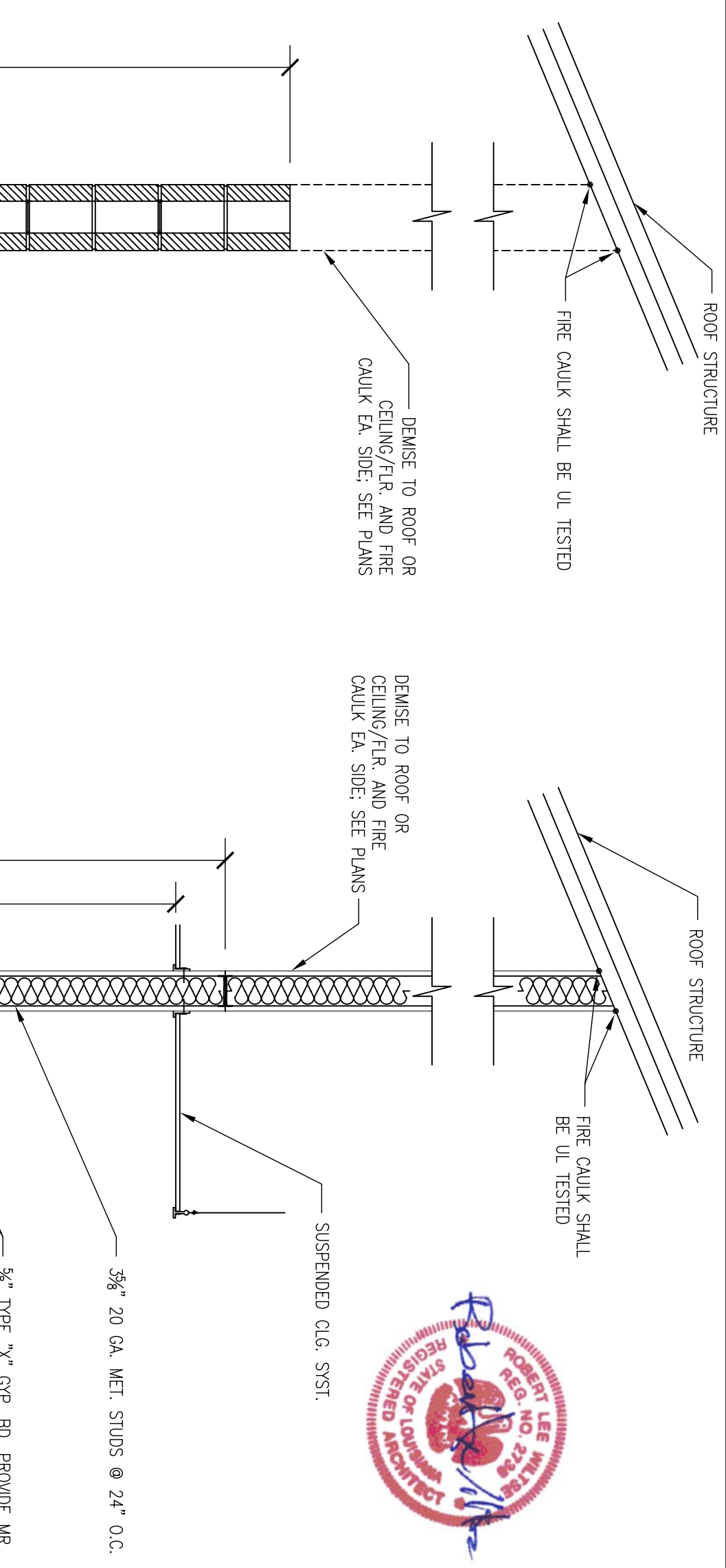

Design No. U905
March 17, 2004

Bearing Wall Rating -- 2 HR
Nonbearing Wall Rating -- 2 HR
Load Restricted for Canadian Applications -- See Guide BXUV7

1. Concrete Blocks* -- Various designs, Classification D-2 (2 hr). See Concrete Blocks category for list of eligible manufacturers.

2. Mortar -- Blocks laid in full bed of mortar, non. 3/8 in. thick, of not less than 2-1/4 and not more than 3-1/2 parts of clean sharp sand to 1 part Portland cement (proportioned by volume) and not more than 50 percent hydrated lime (by cement volume). Vertical joints staggered.

3. Portland Cement Stucco or Gypsum Plaster -- Add 1/2 hr to classification if used. Where combustible members are framed in wall, plaster or stucco must be applied on the face opposite framing to achieve a max. Classification of 1-1/2 hr. Attached to concrete blocks (Item 1).

4. Loose Masonry Fill -- If all core spaces are filled with loose dry expanded slag, expanded clay or shale (Rotary Kiln Process), water repellent vermiculite masonry fill insulation, or silicone treated perlite loose fill insulation add 2 hr to classification.

5. Foamed Plastic* -- (Optional--Not Shown) -- 1-1/2 in. thick max. 4 ft wide sheathing attached to concrete blocks (Item 1).

THE DOW CHEMICAL CO -- Type Thermax

*Bearing the UL Classification Mark

Design No. U465
April 22, 2009

Nonbearing Wall Rating 1 HR

1. Floor and Ceiling Runners -- (not shown) -- Channel shaped runners, 3-5/8 in. wide (min.), 1-1/4 in. legs, 3/8 in. folded back returns, formed from min. No. 25 MSG golv steel, attached to floor and ceiling with fasteners spaced 24 in. OC max.

2. Steel Studs -- Channel shaped, 3-5/8 in. wide (min.), 1-1/4 in. legs, 3/8 in. folded back returns, formed from min. No. 25 MSG golv steel.

3. OC max. Studs to be cut 3/4 in. less than assembly height.

4. Batts and Blankets* -- (Optional) -- Mineral wool or glass fiber bats partially or completely filling stud cavity.

5. Gypsum Board -- 5/8 in. thick, 4 ft wide, attached to steel studs and floor and ceiling track with 1 in. long, Type S steel screws spaced 12 in. along edges of board and 12 in. OC in the field of the board. Joints oriented vertically and staggered on opposite sides of the assembly. When attached to item 6 (resilient channels) or 6A (turning channels), gypsum board is screw attached to furring channels with 1 in. long, Type S steel screws spaced 12 in. OC.

6. Joint Tape and Compound -- Vinyl dry or premixed joint compound, applied in two coats to joints and screw heads; paper tape, 2 in. wide, embedded in first layer of compound over all joints. As an alternate, nominal 3/32 in. thick gypsum veneer plaster may be applied to the entire surface of Classified veneer baseboard. Joints reinforced. Paper tape and joint compound may be omitted when gypsum boards are supplied with square edges.

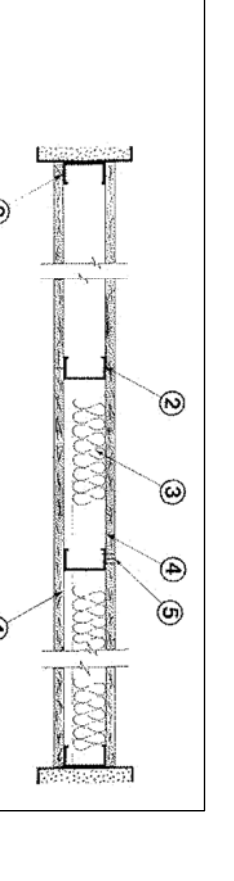

DEPARTMENT OF THE NAVY
NAVAL FACILITIES ENGINEERING COMMAND SOUTHEAST
NAVAL AIR STATION JACKSONVILLE

JOHN C. STENNIS SPACE CENTER
MISSISSIPPI

SOF RIVERINE AND COMBATANT
CRAFT OPERATIONS FACILITY - PRE-FINAL

TYPICAL SECTIONS AND DETAILS

DES. R. WITSE
REVISED BY: R. WITSE
DRAWN: J. JEFFREY

ENGINEERING, INC.
DAMMON ENGINEERING, INC.
1000 W. GULF COAST
SUITE 100
SIBOLLA, LA 70382
(985) 649-4332
ESTABLISHED 1962

REVISAS AS PER URS COMMENTS 9 OCTOBER 2009

SYM	DESCRIPTION	DATE	APPR
		11-6-09	RW

NAVFAC

DESIGN REVISION: 01 JAN 2009

A16

REVDATE:

A

B

C

D

A

B

C

D

1

2

3

4

5

6

7

8

9

10

11

12

13

14

15

16