

- PENETRATION NOTES
1. RISER PIPE CLAMPS SHALL NOT REST ON TOP OF SLEEVE.
  2. ALL SEALANTS SHALL BE INSTALLED IN STRICT ACCORDANCE WITH MANUFACTURER'S INSTRUCTIONS.
  3. SURFACE OF PIPE, SLEEVE, AND CONCRETE SHALL BE FREE OF MOISTURE AND DUST PRIOR TO APPLICATION OF SEALANT.

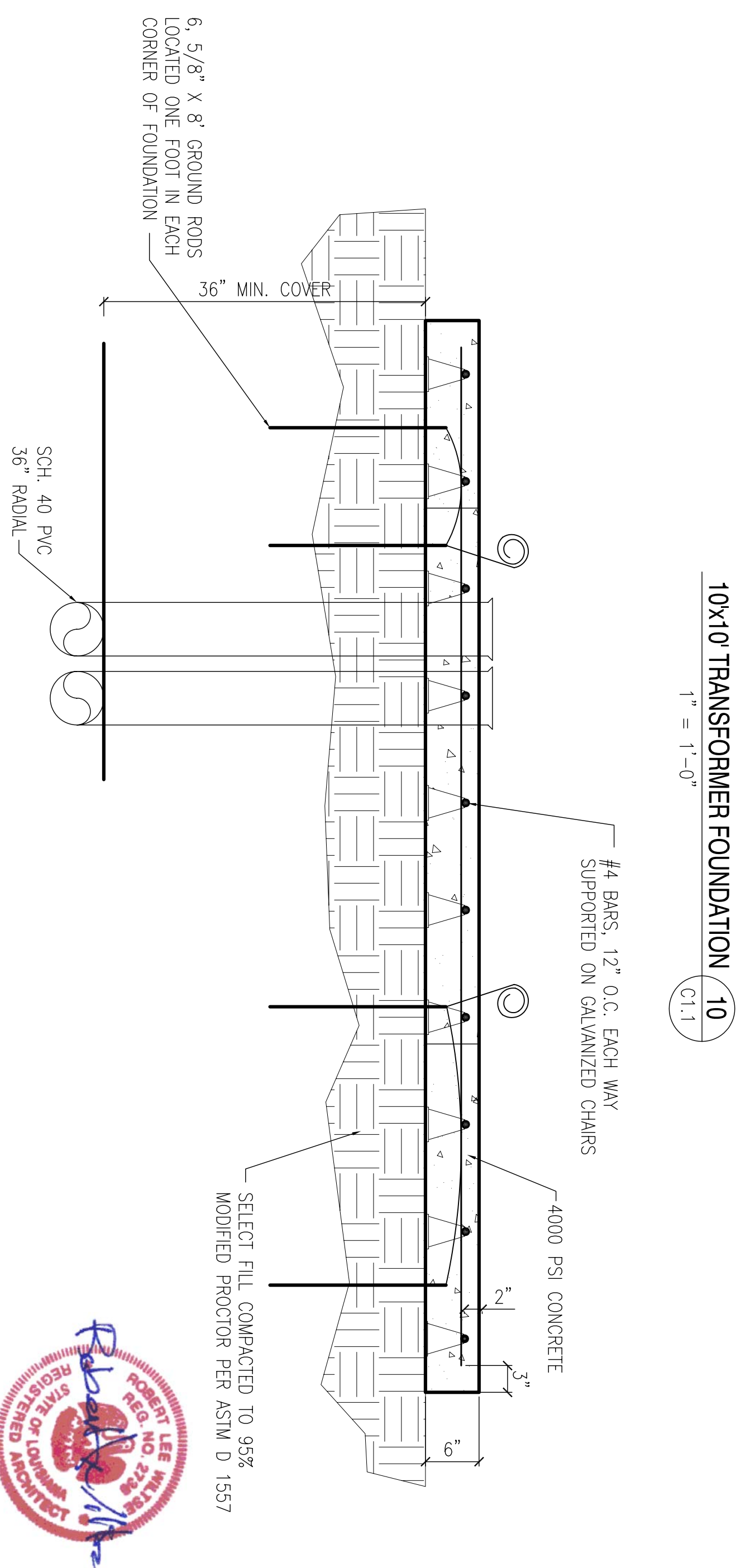
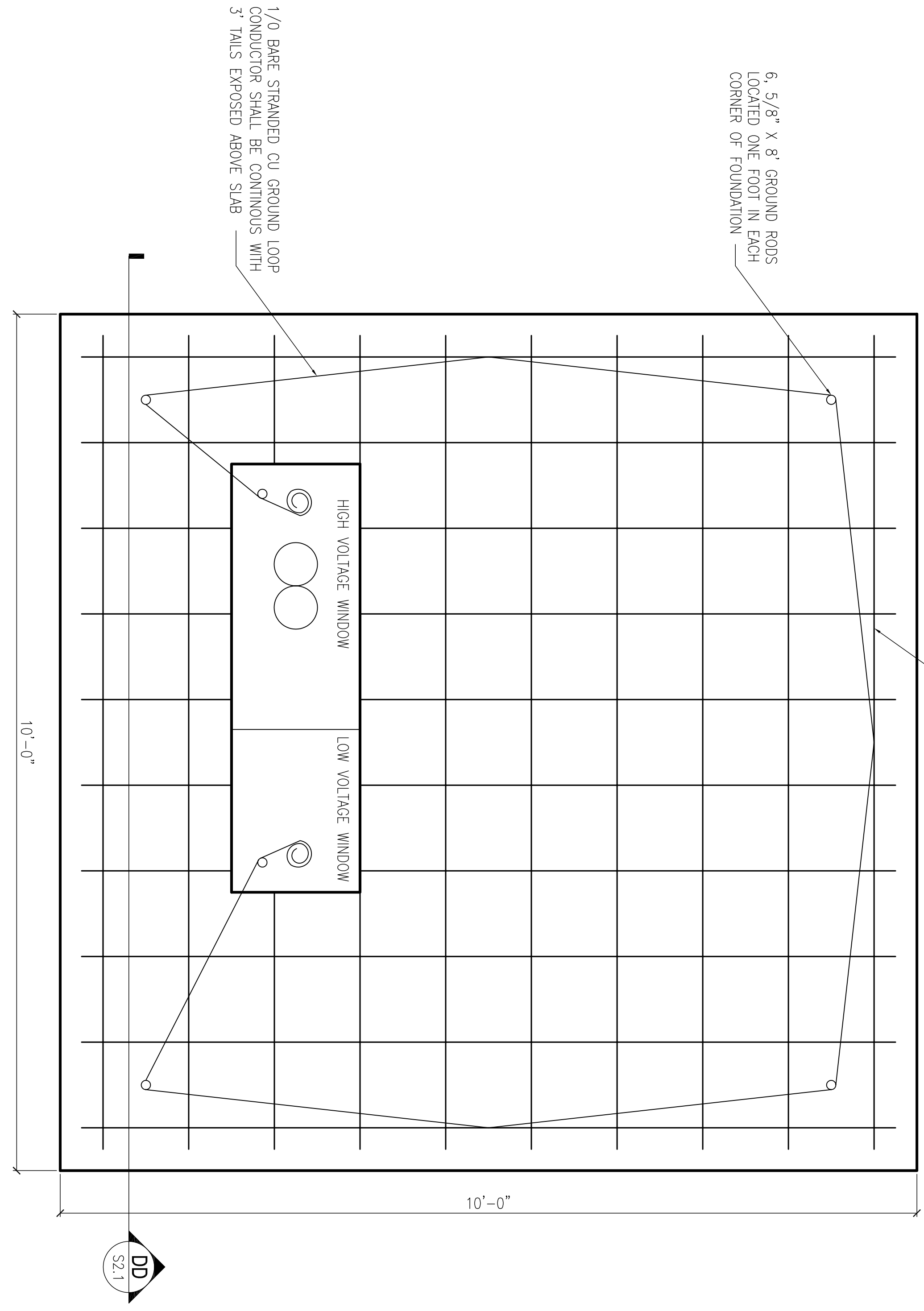
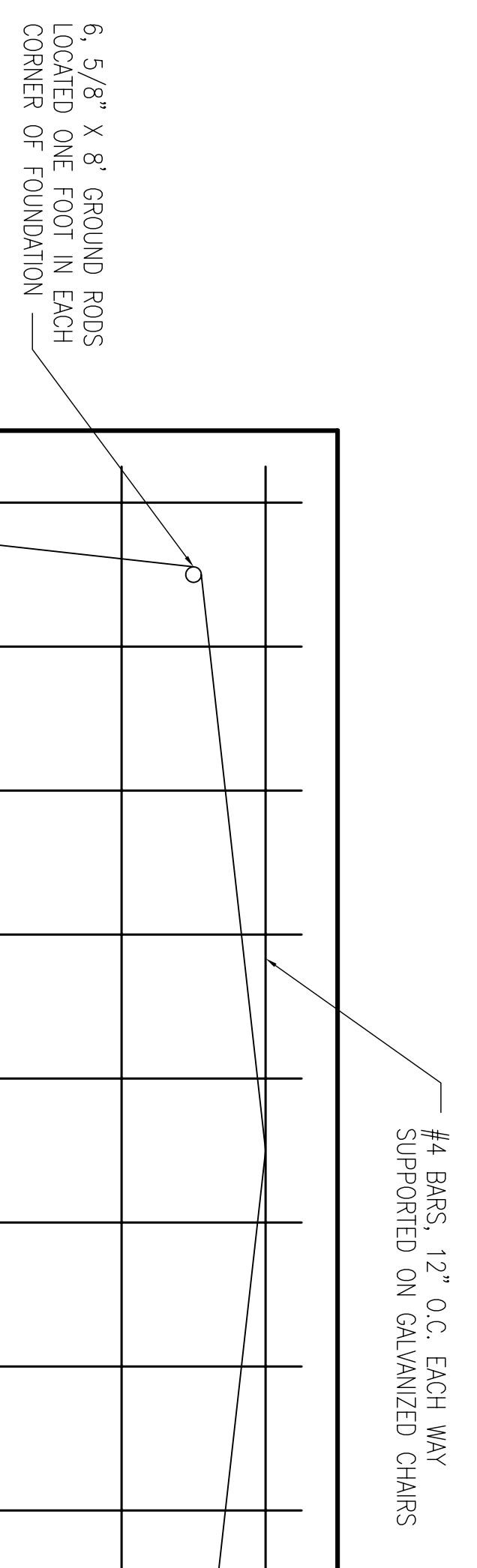
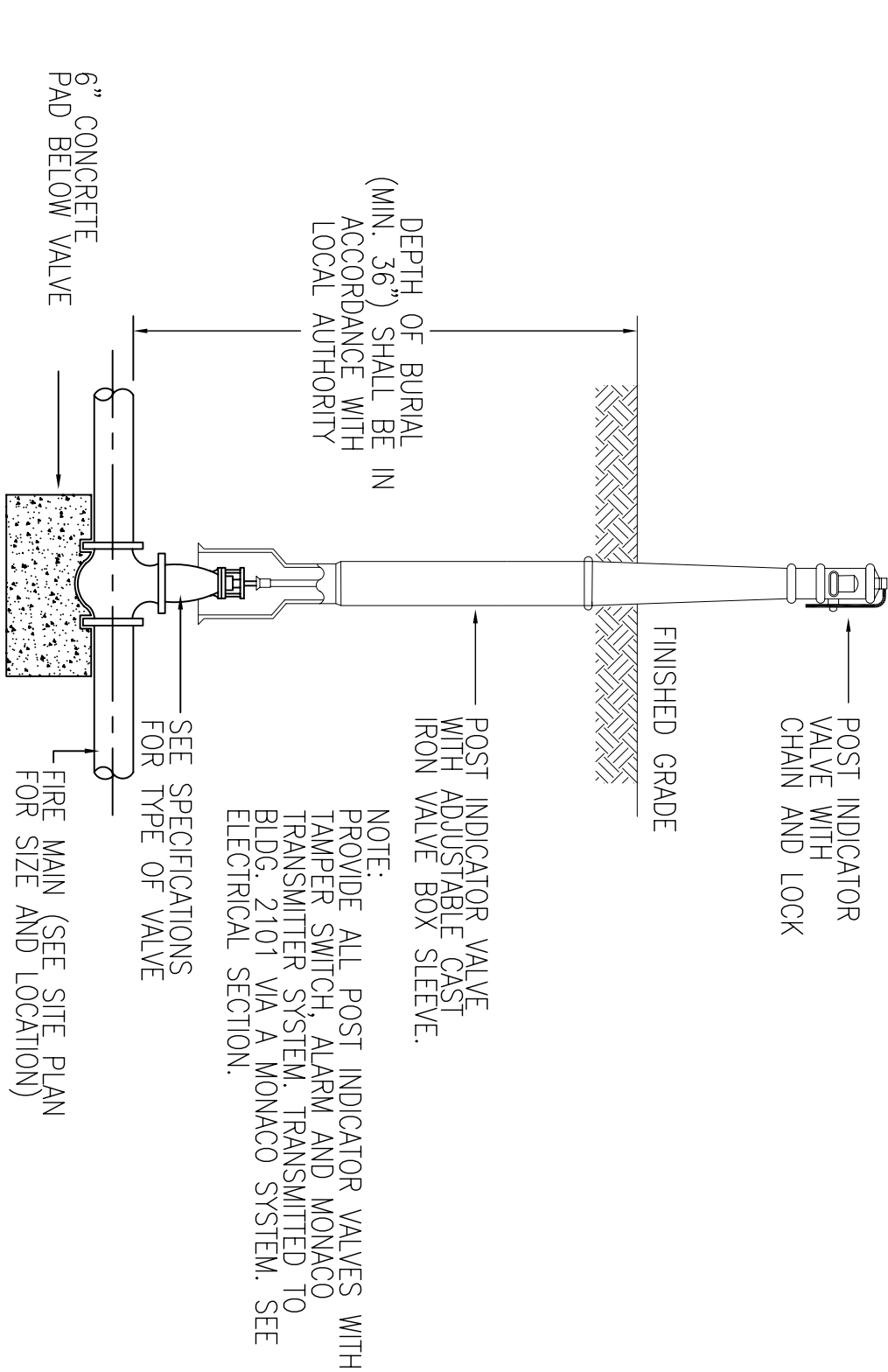

SYM	DESCRIPTION	DATE	APPR
	REVISED AS PER URS COMMENTS 9 OCTOBER 2009	11-6-09	RW

**NAVFAC**

**DAMMON ENGINEERING, INC.**  
REGISTERED PROFESSIONAL ENGINEER  
CHIEF ENGINEER  
DAMMON, P. O. BOX 4439  
SIBOLLA, LA 70582  
(985) 649-4332  
September 4, 2009

**EMMETT B. DAMMON LICENSED PROFESSIONAL ENGINEER STATE OF MISSISSIPPI 9662**

DEPARTMENT OF THE NAVY  
NAVAL FACILITIES ENGINEERING COMMAND  
NAVAL FACILITIES ENGINEERING COMMAND SOUTHEAST  
NAVAL AIR STATION JACKSONVILLE  
MISSISSIPPI  
JOHN C. STENNIS SPACE CENTER  
SOF RIVERINE AND COMBATANT CRAFT OPERATIONS FACILITY - PRE-FINAL  
STRUCTURAL DETAILS

DES: C. DAMMON | DRAW: C. DAMMON  
REVIEWED BY: R. WILSON  
P/W/INK: T. JARRIS  
CHIEF ENGINEER: P. DAMMON

CODE ID: NOK N4412 | SIZE: D  
SCALE: AS SHOWN  
DRAWING NO.: #####  
S/A PROJ. NO.: P-210  
WORK ORDER NO.: 510247  
CONSTR. CONTR. NO.: N62467-05-0-0096  
NAVFAC DRAWING NO.: 15026728  
SHEET: 81 OF 132

**S4.1**

DATE: 01 JAN 2009