



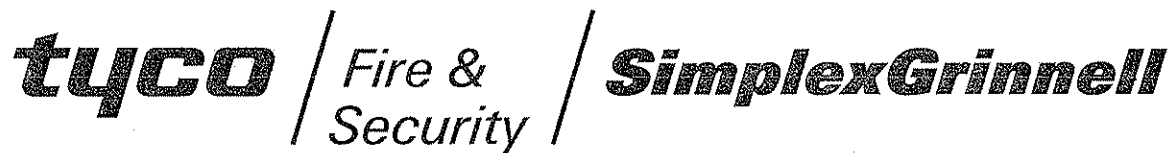
# FIRE PROTECTION SPECIFICATIONS

SOF RIVERINE AND COMBATANT  
CRAFT OPERATIONS FACILITY  
N 62467-05-D-0096

**FINAL DESIGN ISSUE  
SEPTEMBER 4, 2009**

US DEPARTMENT OF THE NAVY – NAVFAC SOUTHEAST

*Prepared by:*  
Dammon Engineering  
1095 Florida Avenue  
Slidell, La. 70458  
985-649-5832  
[dammonengineering.com](http://dammonengineering.com)

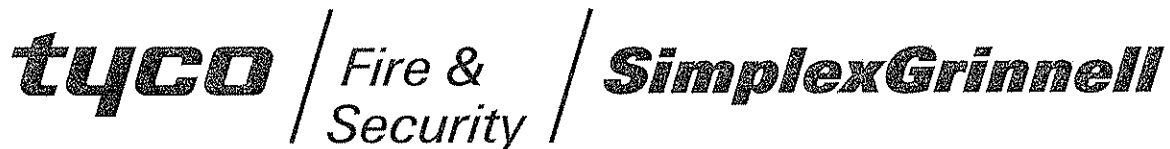


**STENNIS RIVERINE & COMBATANT**  
**TRAINING FACILITY**  
**STENNIS SPACE CENTER**  
**STENNIS, MS 39529**

**FIRE PROTECTION**  
**SUBMITTAL**

**REVISION 2**  
**SEPTEMBER 14, 2009**

**SIMPLEXGRINNELL**  
**5800 JEFFERSON HWY., SUITE A**  
**HARAHAN, LA 70123**  
**PHONE: 504-736-0104**  
**FAX: 504-736-9292**



**STENNIS RIVERINE & COMBATANT TRAINING**  
**FACILITY**  
**STENNIS SPACE CENTER**  
**STENNIS, MS 39529**

**FIRE PROTECTION/ SPRINKLER SYSTEMS**  
**OPERATIONS BUILDING 2440/2441**  
**BOAT STORAGE BUILDING 2442**

**TABLE OF CONTENTS**

**SECTION 1 - SPRINKLERS**

**SECTION 2 - VALVES AND DEVICES**

**SECTION 3 - FITTINGS**

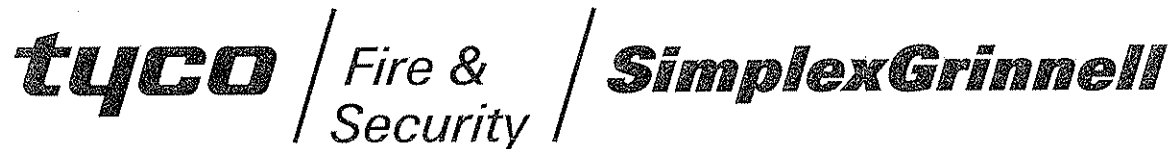
**SECTION 4 - PIPE HANGERS AND SUPPORTS**

**SECTION 5 - HYDRAULIC CALCULATIONS**

**SECTION 6 - HYDRAULIC CALCULATIONS**  
**WITH HOSE ALLOWANCE**  
**FOR REFERENCE ONLY**

**SECTION 7 - SEISMIC CALCULATIONS**

**SIMPLEXGRINNELL**  
**5800 JEFFERSON HWY., SUITE A**  
**HARAHAN, LA 70123**  
**PHONE: 504-736-0104**  
**FAX: 504-736-9292**



**STENNIS RIVERINE & COMBATANT TRAINING**  
**FACILITY**  
**STENNIS SPACE CENTER**  
**STENNIS, MS 39529**

**FIRE PROTECTION/ SPRINKLER SYSTEMS**  
**OPERATIONS BUILDING 2440/2441**  
**BOAT STORAGE BUILDING 2442**

# **SECTION 1**

# **SPRINKLERS**

**SIMPLEXGRINNELL**  
**5800 JEFFERSON HWY., SUITE A**  
**HARAHAN, LA 70123**  
**PHONE: 504-736-0104**  
**FAX: 504-736-9292**

## Series TY-FRB — 2.8, 4.2, 5.6, and 8.0 K-factor Upright, Pendent, and Recessed Pendent Sprinklers Quick Response, Standard Coverage

### General Description

The Tyco® Series TY-FRB, 2.8, 4.2, 5.6, and 8.0 K-factor, Upright and Pendent Sprinklers described in this data sheet are quick response - standard coverage, decorative 3 mm glass bulb type spray sprinklers designed for use in light or ordinary hazard, commercial occupancies such as banks, hotels, shopping malls, etc.

The recessed version of the Series TY-FRB Pendent Sprinkler, where applicable, is intended for use in areas with a finished ceiling. It uses either a two-piece Style 10 (1/2 inch NPT) or Style 40 (3/4 inch NPT) Recessed Escutcheon with 1/2 inch (12,7 mm) of recessed adjustment or up to 3/4 inch (19,1 mm) of total adjustment from the flush pendent position, or a two-piece Style 20 (1/2 inch NPT) or Style 30 (3/4 inch NPT) Recessed Escutcheon with 1/4 inch (6,4 mm) of recessed adjustment or up to 1/2 inch (12,7 mm) of total adjustment from the flush pendent position. The adjustment provided by the Recessed Escutcheon reduces the accuracy to which the fixed pipe drops to the sprinklers must be cut.

Corrosion resistant coatings, where applicable, are utilized to extend the life of copper alloy sprinklers beyond that which would otherwise be ob-

#### IMPORTANT

Always refer to Technical Data Sheet TFP700 for the "INSTALLER WARNING" that provides cautions with respect to handling and installation of sprinkler systems and components. Improper handling and installation can permanently damage a sprinkler system or its components and cause the sprinkler to fail to operate in a fire situation or cause it to operate prematurely.

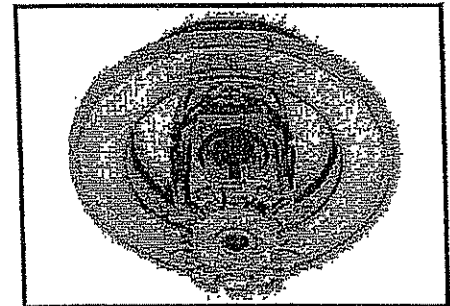
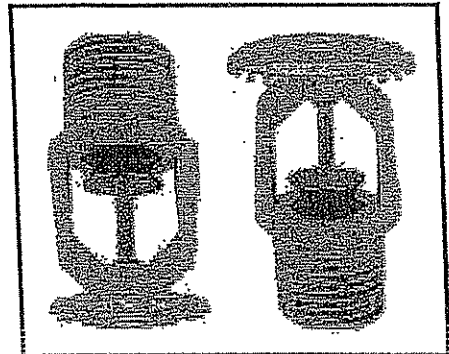
tained when exposed to corrosive atmospheres. Although corrosion resistant coated sprinklers have passed the standard corrosion tests of the applicable approval agencies, the testing is not representative of all possible corrosive atmospheres. Consequently, it is recommended that the end user be consulted with respect to the suitability of these coatings for any given corrosive environment. The effects of ambient temperature, concentration of chemicals, and gas/chemical velocity, should be considered, as a minimum, along with the corrosive nature of the chemical to which the sprinklers will be exposed.

An intermediate level versions of the Series TY-FRB Pendent Sprinklers are detailed in Technical Data Sheet TFP356, and Sprinkler Guards are detailed in Technical Data Sheet TFP780

#### WARNINGS

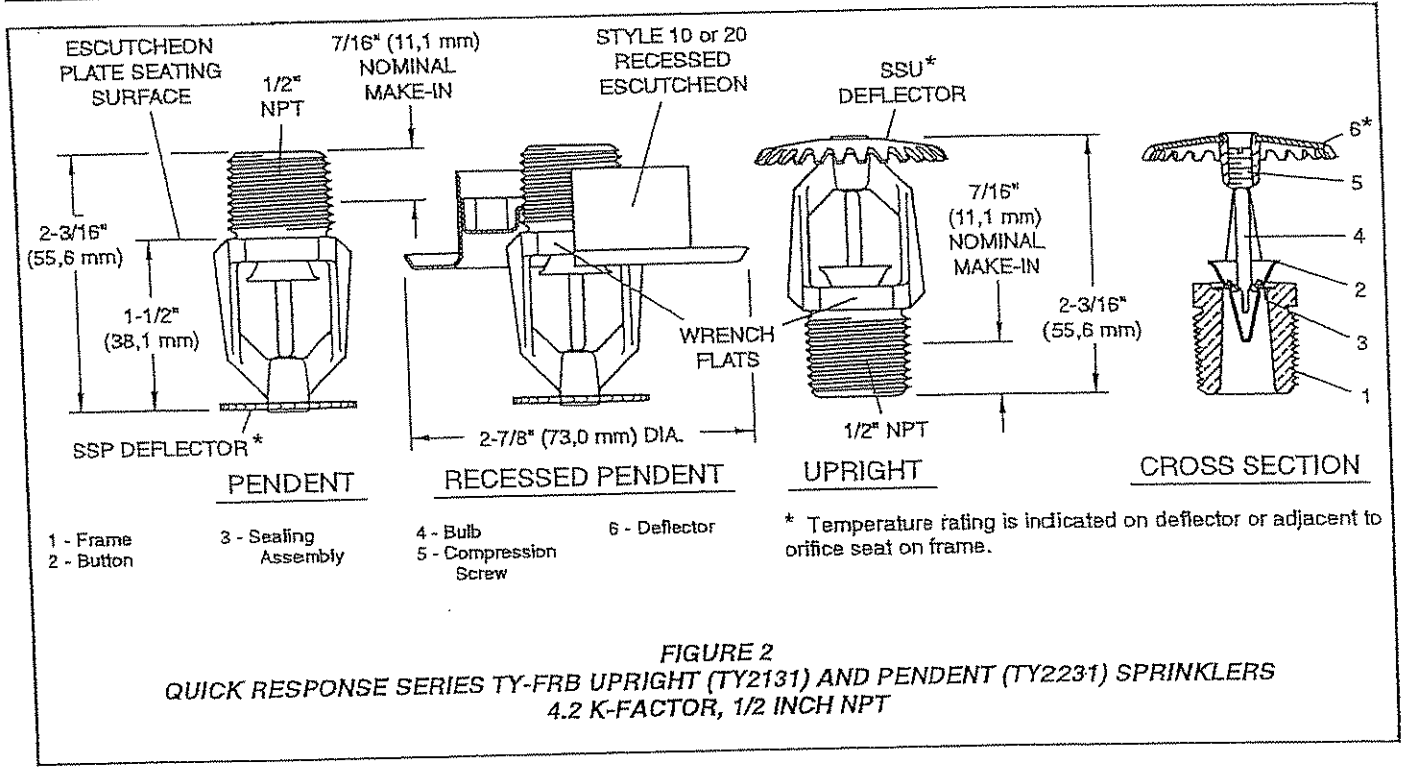
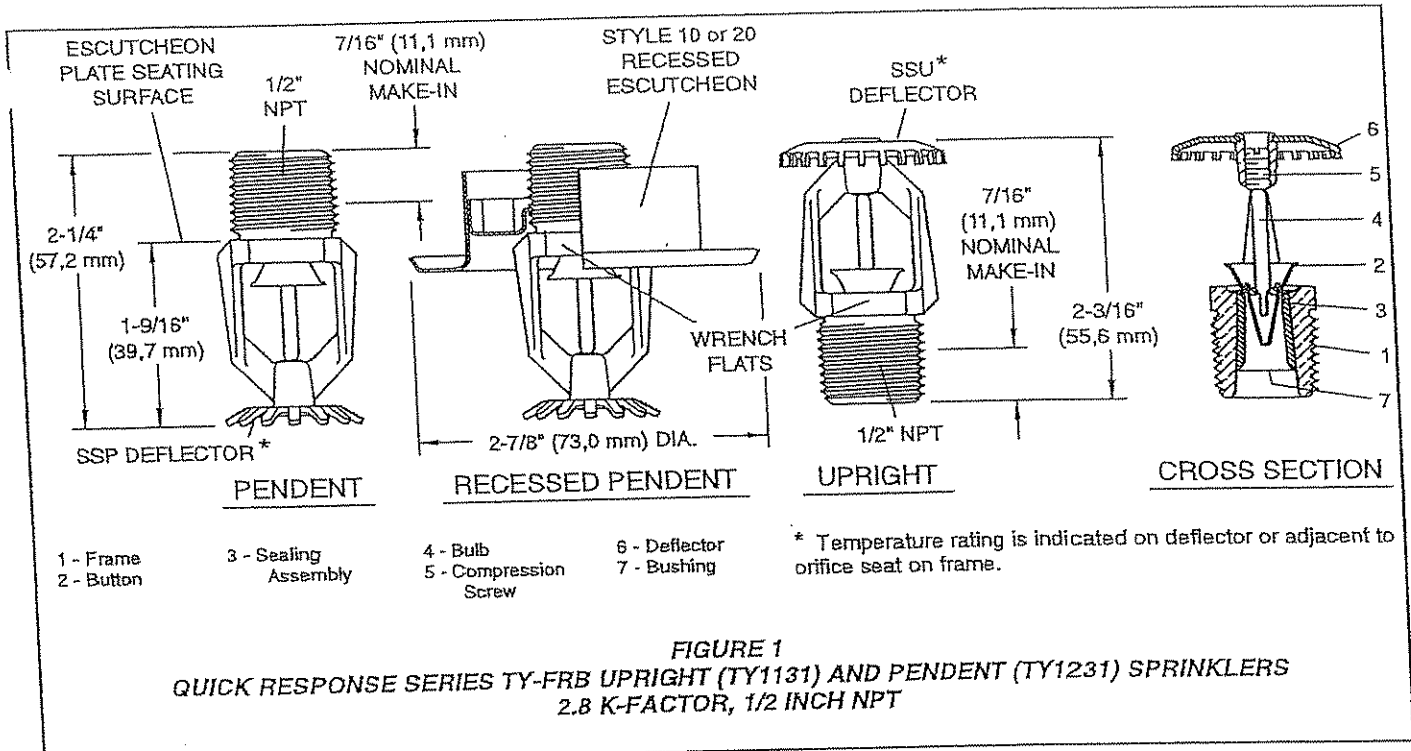
*The Series TY-FRB Sprinklers described herein must be installed and maintained in compliance with this document, as well as with the applicable standards of the National Fire Protection Association, in addition to the standards of any other authorities having jurisdiction. Failure to do so may impair the performance of these devices.*

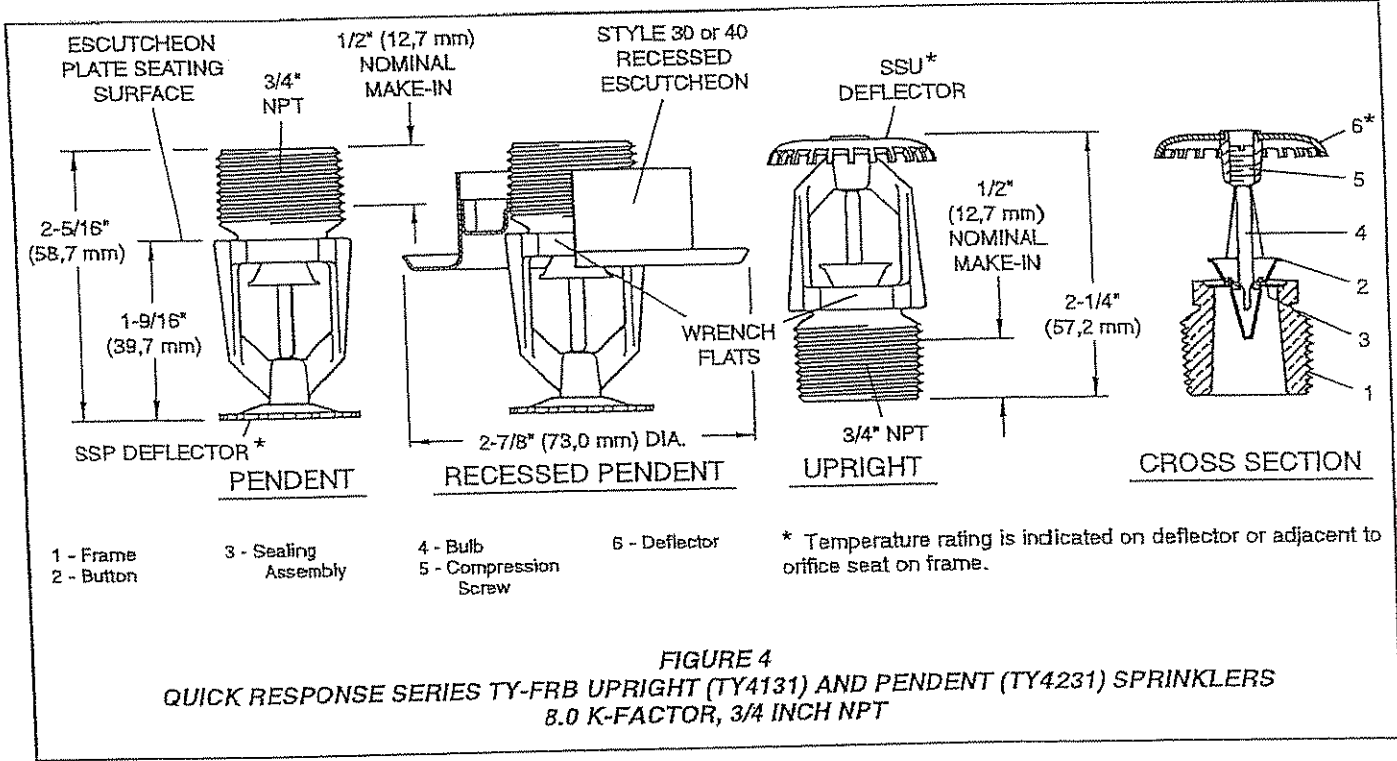
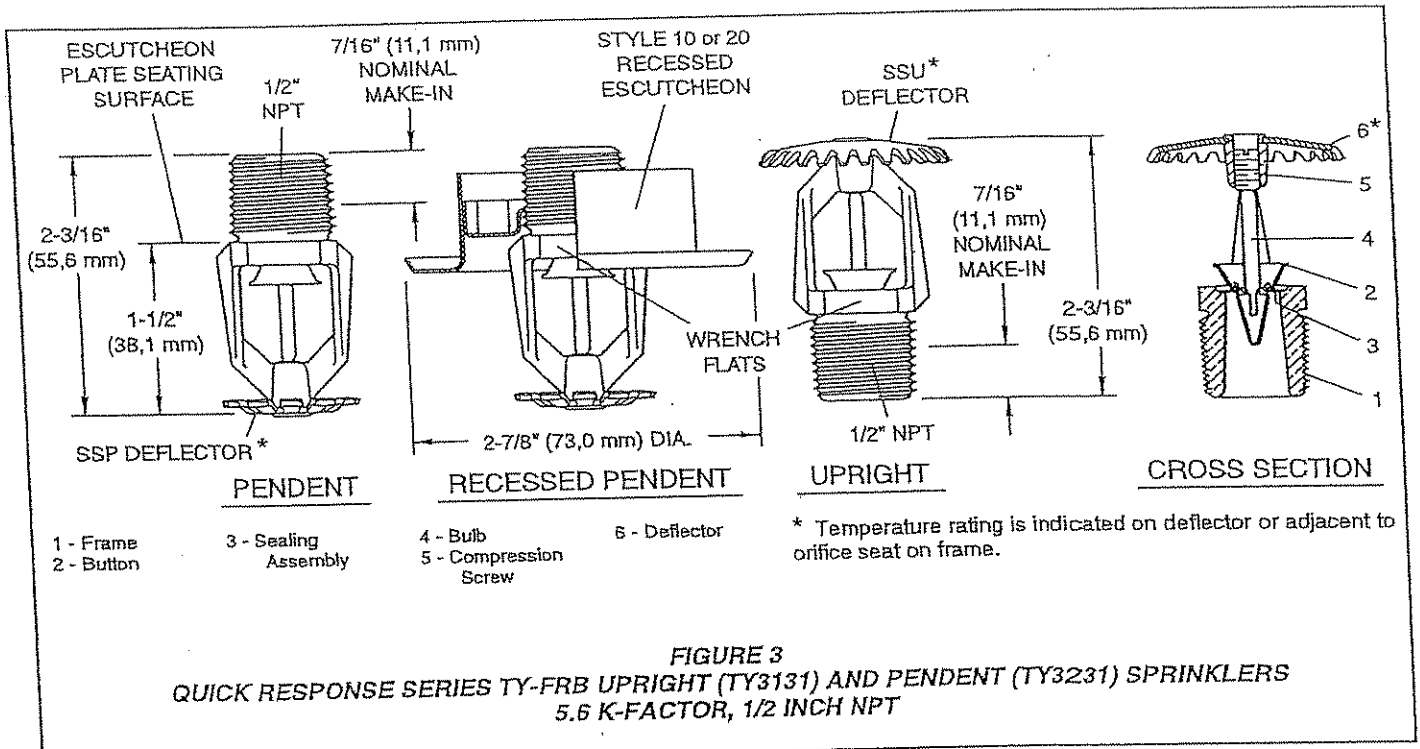
*The owner is responsible for maintaining their fire protection system and devices in proper operating condition. The installing contractor or sprinkler manufacturer should be contacted with any questions.*

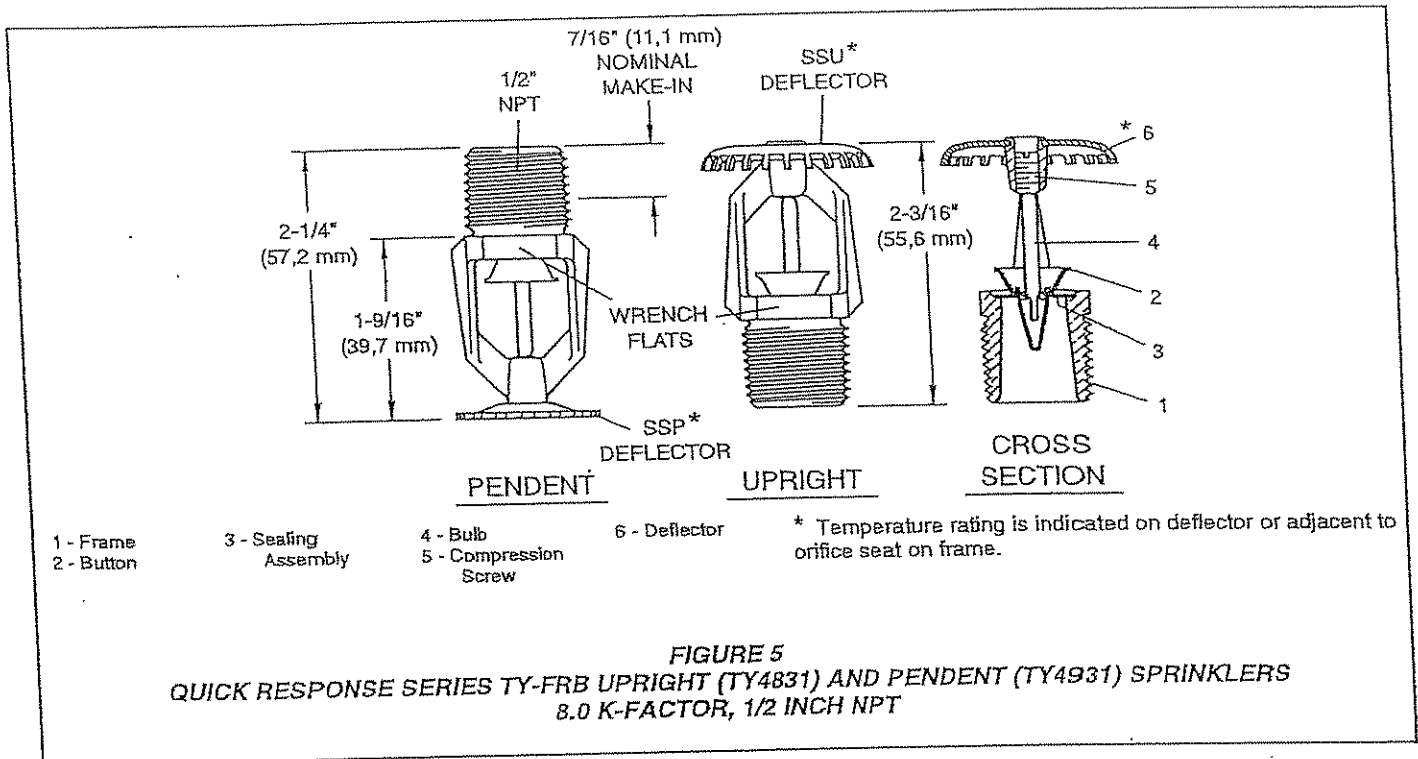


### Model/Sprinkler Identification Numbers

TY1131 -	Upright 2.8K, 1/2" NPT
TY1231 -	Pendent 2.8K, 1/2" NPT
TY2131 -	Upright 4.2K, 1/2" NPT
TY2231 -	Pendent 4.2K, 1/2" NPT
TY3131 -	Upright 5.6K, 1/2" NPT
TY3231 -	Pendent 5.6K, 1/2" NPT
TY4131 -	Upright 8.0K, 3/4" NPT
TY4231 -	Pendent 8.0K, 3/4" NPT
TY4831 -	Upright 8.0K, 1/2" NPT
TY4931 -	Pendent 8.0K, 1/2" NPT







## Technical Data

### Approvals

UL and C-UL Listed.  
 FM, LPCB, and NYC Approved.  
 (Refer to Table A and B for complete approval information including corrosion resistant status.)

### Maximum Working Pressure

Refer to Table C.

### Discharge Coefficient

K = 2.8 GPM/psi<sup>1/2</sup> (40,3 LPM/bar<sup>1/2</sup>)  
 K = 4.2 GPM/psi<sup>1/2</sup> (60,5 LPM/bar<sup>1/2</sup>)  
 K = 5.6 GPM/psi<sup>1/2</sup> (80,6 LPM/bar<sup>1/2</sup>)  
 K = 8.0 GPM/psi<sup>1/2</sup> (115,2 LPM/bar<sup>1/2</sup>)

### Temperature Ratings

Refer to Table A and B

### Finishes

Sprinkler: Refer to Table A and B.  
 Recessed Escutcheon: White Coated, Chrome Plated, or Brass Plated.

### Physical Characteristics

Frame . . . . . Bronze  
 Button . . . . . Brass/Copper  
 Sealing Assembly . . . . .  
 . . . . . Beryllium Nickel w/Teflon†  
 Bulb . . . . . Glass  
 Compression Screw . . . . . Bronze  
 Deflector . . . . . Copper/Bronze  
 Bushing (K=2.8) . . . . . Bronze

## Operation

The glass Bulb contains a fluid which expands when exposed to heat. When the rated temperature is reached, the fluid expands sufficiently to shatter the glass Bulb, allowing the sprinkler to activate and water to flow.

## Design Criteria

The Series TY-FRB Pendent and Upright Sprinklers are intended for fire protection systems designed in accordance with the standard installation rules recognized by the applicable Listing or Approval agency (e.g., UL Listing is based on the requirements of NFPA 13, and FM Approval is based on the requirements of FM's Loss Prevention Data Sheets). Only the Style 10, 20, 30, or 40 Recessed Escutcheon, as applicable, is to be used for recessed pendent installations.

K	TYPE	TEMP.	BULB LIQUID	SPRINKLER FINISH (See Note 7)								
				NATURAL BRASS	CHROME PLATED	WHITE*** POLYESTER						
2.8 1/2" NPT	PENDENT (TY1231) and UPRIGHT (TY1131)	135°F/57°C	Orange	1, 2, 3, 5								
		155°F/68°C	Red									
		175°F/79°C	Yellow									
		200°F/93°C	Green									
		286°F/141°C	Blue									
	RECESSED PENDENT (TY1231)* Figure 6	135°F/57°C	Orange				1, 2, 5					
		155°F/68°C	Red									
		175°F/79°C	Yellow									
		200°F/93°C	Green									
	RECESSED PENDENT (TY1231)** Figure 7	135°F/57°C	Orange							1, 2, 5		
		155°F/68°C	Red									
		175°F/79°C	Yellow									
200°F/93°C		Green										
4.2 1/2" NPT	PENDENT (TY2231) and UPRIGHT (TY2131)	135°F/57°C	Orange	1, 2								
		155°F/68°C	Red									
		175°F/79°C	Yellow									
		200°F/93°C	Green									
		286°F/141°C	Blue									
	RECESSED PENDENT (TY2231)* Figure 8	135°F/57°C	Orange				1, 2					
		155°F/68°C	Red									
		175°F/79°C	Yellow									
		200°F/93°C	Green									
	RECESSED PENDENT (TY2231)** Figure 9	135°F/57°C	Orange							1, 2		
		155°F/68°C	Red									
		175°F/79°C	Yellow									
		200°F/93°C	Green									
		200°F/93°C	Green									

## NOTES:

1. Listed by Underwriters Laboratories, Inc. (UL) as Quick Response Sprinklers.
  2. Listed by Underwriters Laboratories, Inc. for use in Canada (C-UL) as Quick Response Sprinklers.
  3. Approved by Factory Mutual Research Corporation (FM) as Quick Response Sprinklers.
  5. Approved by the City of New York under MEA 354-01-E.
  7. Where Polyester Coated Sprinklers are noted to be UL and C-UL Listed, the sprinklers are UL and C-UL Listed as Corrosion Resistant Sprinklers.
- \* Installed with Style 10 (1/2" NPT) or Style 40 (3/4" NPT) 3/4" Total Adjustment Recessed Escutcheon, as applicable.
- \*\* Installed with Style 20 (1/2" NPT) or Style 30 (3/4" NPT) 1/2" Total Adjustment Recessed Escutcheon, as applicable.
- \*\*\* Frame and Deflector only. Listings and approvals apply to color (Special Order).
- N/A: Not Available

**TABLE A**  
**LABORATORY LISTINGS AND APPROVALS**  
**2.8 AND 4.2 K-FACTOR SPRINKLERS**

K	TYPE	TEMP.	BULB LIQUID	SPRINKLER FINISH (See Note B)			LEAD COATED
				NATURAL BRASS	CHROME PLATED	WHITE*** POLYESTER	
5.6 1/2" NPT	PENDENT (TY3231) and UPRIGHT (TY3131)	135°F/57°C	Orange	1, 2, 3, 4, 5, 6, 7			1, 2, 3, 5
		155°F/68°C	Red				
		175°F/79°C	Yellow				
		200°F/93°C	Green				
		286°F/141°C	Blue				
	RECESSED PENDENT (TY3231)* Figure 10	135°F/57°C	Orange	1, 2, 4, 5			N/A
		155°F/68°C	Red				
		175°F/79°C	Yellow				
		200°F/93°C	Green				
	RECESSED PENDENT (TY3231)** Figure 11	135°F/57°C	Orange	1, 2, 3, 4, 5			N/A
		155°F/68°C	Red				
		175°F/79°C	Yellow				
200°F/93°C		Green					
8.0 3/4" NPT	PENDENT (TY4231) and UPRIGHT (TY4131)	135°F/57°C	Orange	1, 2, 3, 4, 5, 6, 7			1, 2, 5
		155°F/68°C	Red				
		175°F/79°C	Yellow				
		200°F/93°C	Green				
		286°F/141°C	Blue				
	RECESSED PENDENT (TY4231)* Figure 12	135°F/57°C	Green	1, 2, 4, 5			N/A
		155°F/68°C	Orange				
		175°F/79°C	Red				
		200°F/93°C	Yellow				
	RECESSED PENDENT (TY4231)** Figure 13	135°F/57°C	Orange	1, 2, 3, 4, 5			N/A
		155°F/68°C	Red				
		175°F/79°C	Yellow				
200°F/93°C		Green					
8.0 1/2" NPT	PENDENT (TY4931) and UPRIGHT (TY4831)	135°F/57°C	Orange	1, 2, 4, 5, 6			1, 2, 5
		155°F/68°C	Red				
		175°F/79°C	Yellow				
		200°F/93°C	Green				
		286°F/141°C	Blue				

NOTES:

- Listed by Underwriters Laboratories, Inc. (UL) as Quick Response Sprinklers.
- Listed by Underwriters Laboratories, Inc. for use in Canada (C-UL) as Quick Response Sprinklers.
- Approved by Factory Mutual Research Corporation (FM) as Quick Response Sprinklers.
- Approved by the Loss Prevention Certification Board (LPCB Ref. No. 007k/04) as Quick Response Sprinklers; however, the LPCB does not rate the thermal sensitivity of recessed sprinklers.
- Approved by the City of New York under MEA 354-01-E.
- Vds Approved (For details contact Tyco Fire & Building Products, Enschede, Netherlands, Tel. 31-53-428-4444/Fax 31-53-428-3377).
- Approved by the Loss Prevention Certification Board (LPCB Ref. No. 094a/06) as Quick Response Sprinklers.
- Where Polyester Coated and Lead Coated Sprinklers are noted to be UL and C-UL Listed, the sprinklers are UL and C-UL Listed as Corrosion Resistant Sprinklers. Where Lead Coated Sprinklers are noted to be FM Approved, the sprinklers are FM Approved as a Corrosion Resistant Sprinklers.

\* Installed with Style 10 (1/2" NPT) or Style 40 (3/4" NPT) 3/4" Total Adjustment Recessed Escutcheon, as applicable.

\*\* Installed with Style 20 (1/2" NPT) or Style 30 (3/4" NPT) 1/2" Total Adjustment Recessed Escutcheon, as applicable.

\*\*\* Frame and Deflector only. Listings and approvals apply to color (Special Order).

N/A: Not Available

**TABLE B**  
**LABORATORY LISTINGS AND APPROVALS**  
**5.6 AND 8.0 K-FACTOR SPRINKLERS**

K	TYPE	SPRINKLER FINISH			LEAD COATED
		NATURAL BRASS	CHROME PLATED	WHITE POLYESTER	
2.8 1/2" NPT	PENDENT (TY3231) and UPRIGHT (TY3131)	175 PSI (12,1 BAR)			N/A
	RECESSED PENDENT (TY323)				
4.2 3/4" NPT	PENDENT (TY4231) and UPRIGHT (TY4131)	175 PSI (12,1 BAR)			N/A
	RECESSED PENDENT (TY4231)				
5.6 1/2" NPT	PENDENT (TY3231) and UPRIGHT (TY3131)	250 PSI (17,2 BAR) OR 175 PSI (12,1 BAR)			175 PSI (12,1 BAR)
	RECESSED PENDENT (TY3231)	(SEE NOTE 1)			N/A
8.0 3/4" NPT	PENDENT (TY4231) and UPRIGHT (TY4131)	175 PSI (12,1 BAR)			175 PSI (12,1 BAR)
	RECESSED PENDENT (TY4231)				N/A
8.0 1/2" NPT	PENDENT (TY4931) and UPRIGHT (TY4831)	175 PSI (12,1 BAR)			175 PSI (12,1 BAR)

## NOTES:

1. The maximum working pressure of 250 psi (17,2 bar) only applies to the Listing by Underwriters Laboratories Inc. (UL); the Listing by Underwriters Laboratories, Inc. for use in Canada (C-UL); and , the Approval by the City of New York.

TABLE C, MAXIMUM WORKING PRESSURE

## Installation

The Series TY-FRB Sprinklers must be installed in accordance with the following instructions:

### NOTES

Do not install any bulb type sprinkler if the bulb is cracked or there is a loss of liquid from the bulb. With the sprinkler held horizontally, a small air bubble should be present. The diameter of the air bubble is approximately 1/16 inch (1,6 mm) for the 135°F/57°C to 3/32 inch (2,4 mm) for the 286°F/141°C temperature ratings.

A leak tight 1/2 inch NPT sprinkler joint should be obtained with a torque of 7 to 14 ft.lbs. (9,5 to 19,0 Nm). A maximum of 21 ft. lbs. (28,5 Nm) of torque may be used to install sprinklers with 1/2 NPT connections. A leak tight 3/4 inch NPT sprinkler joint should be ob-

tained with a torque of 10 to 20 ft.lbs. (13,4 to 26,8 Nm). A maximum of 30 ft.lbs. (40,7 Nm) of torque is to be used to install sprinklers with 3/4 NPT connections. Higher levels of torque may distort the sprinkler inlet and cause leakage or impairment of the sprinkler.

Do not attempt to make-up for insufficient adjustment in the escutcheon plate by under- or over-tightening the sprinkler. Readjust the position of the sprinkler fitting to suit.

The Series TY-FRB Pendent and Upright Sprinklers must be installed in accordance with the following instructions.

**Step 1.** Pendent sprinklers are to be installed in the pendent position, and upright sprinklers are to be installed in the upright position.

**Step 2.** With pipe thread sealant applied to the pipe threads, hand tighten

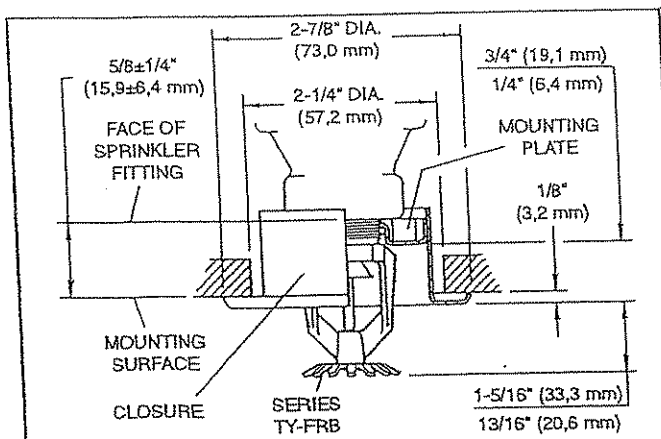
the sprinkler into the sprinkler fitting.

**Step 3.** Tighten the sprinkler into the sprinkler fitting using only the W-Type 6 Sprinkler Wrench (Ref. Figure 14). With reference to Figures 1, 2, 3, 4, and 5, the W-Type 6 Sprinkler Wrench is to be applied to the sprinkler wrench flats.

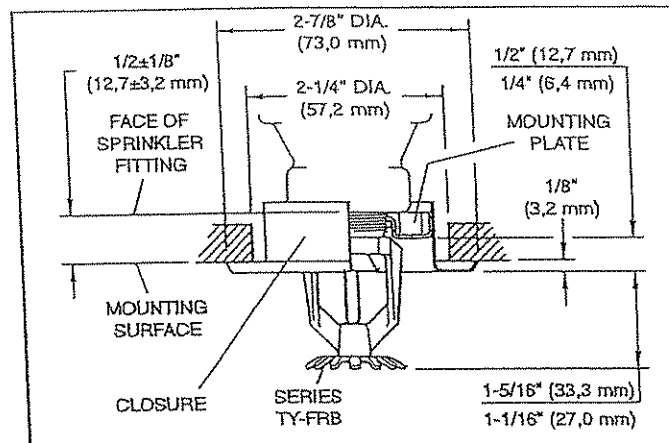
The Series TY-FRB Recessed Pendent Sprinklers must be installed in accordance with the following instructions.

**Step A.** After installing the Style 10, 20, 30, or 40 Mounting Plate, as applicable, over the sprinkler threads and with pipe thread sealant applied to the pipe threads, hand tighten the sprinkler into the sprinkler fitting.

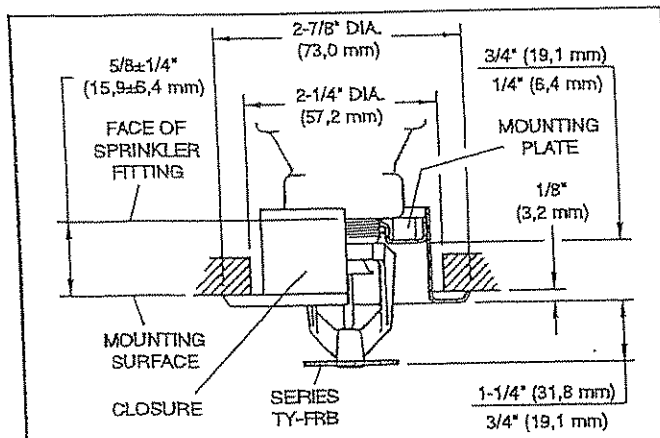
**Step B.** Tighten the sprinkler into the sprinkler fitting using only the W-Type 7 Recessed Sprinkler Wrench (Ref. Figure 15). With reference to Figure 1, 2, 3, and 4, the W-Type 7 Recessed



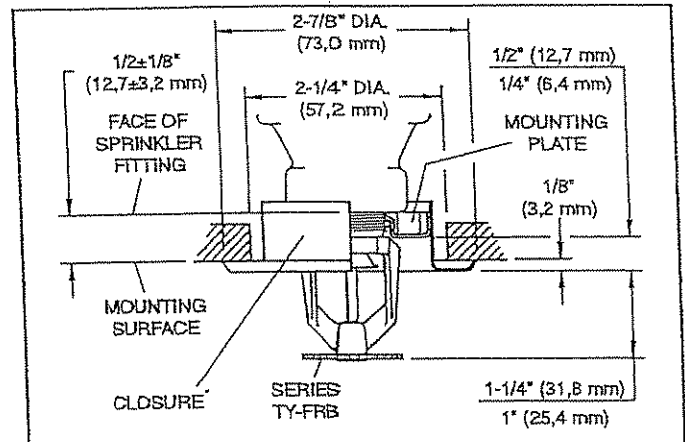
**FIGURE 6**  
**SERIES TY-FRB RECESSED PENDENT**  
**WITH TWO-PIECE 3/4 INCH TOTAL ADJUSTMENT**  
**STYLE 10 RECESSED ESCUTCHEON**  
**2.8 K-FACTOR, 1/2 INCH NPT**



**FIGURE 7**  
**SERIES TY-FRB RECESSED PENDENT**  
**WITH TWO-PIECE 1/2 INCH TOTAL ADJUSTMENT**  
**STYLE 20 RECESSED ESCUTCHEON**  
**2.8 K-FACTOR, 1/2 INCH NPT**



**FIGURE 8**  
**SERIES TY-FRB RECESSED PENDENT**  
**WITH TWO-PIECE 3/4 INCH TOTAL ADJUSTMENT**  
**STYLE 10 RECESSED ESCUTCHEON**  
**4.2 K-FACTOR, 1/2 INCH NPT**



**FIGURE 9**  
**SERIES TY-FRB RECESSED PENDENT**  
**WITH TWO-PIECE 1/2 INCH TOTAL ADJUSTMENT**  
**STYLE 20 RECESSED ESCUTCHEON**  
**4.2 K-FACTOR, 1/2 INCH NPT**

Sprinkler Wrench is to be applied to the sprinkler wrench flats.

Step C. After the ceiling has been installed or the finish coat has been applied, slide on the Style 10, 20, 30, or 40 Closure over the Series TY-FRB Sprinkler and push the Closure over the Mounting Plate until its flange comes in contact with the ceiling.

## Care and Maintenance

The Series TY-FRB Sprinklers must be maintained and serviced in accordance with the following instructions:

### NOTES

Before closing a fire protection system main control valve for maintenance

work on the fire protection system that it controls, permission to shut down the affected fire protection system must be obtained from the proper authorities and all personnel who may be affected by this action must be notified.

The owner must assure that the sprinklers are not used for hanging of any objects; otherwise, non-operation in the event of a fire or inadvertent operation may result.

Absence of an escutcheon, which is used to cover a clearance hole, may delay the time to sprinkler operation in a fire situation.

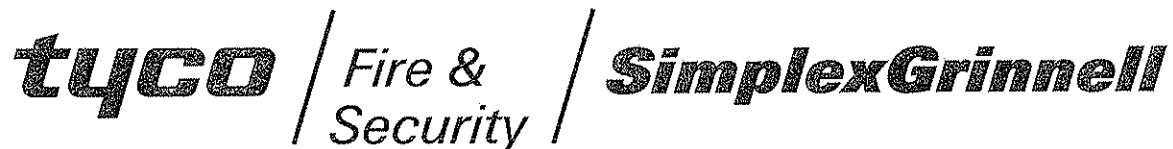
Sprinklers that are found to be leaking or exhibiting visible signs of corrosion must be replaced.

Automatic sprinklers must never be painted, plated, coated or otherwise

altered after leaving the factory. Modified sprinklers must be replaced. Sprinklers that have been exposed to corrosive products of combustion, but have not operated, should be replaced if they cannot be completely cleaned by wiping the sprinkler with a cloth or by brushing it with a soft bristle brush.

Care must be exercised to avoid damage to the sprinklers - before, during, and after installation. Sprinklers damaged by dropping, striking, wrench twist/slippage, or the like, must be replaced. Also, replace any sprinkler that has a cracked bulb or that has lost liquid from its bulb. (Ref. Installation Section).

Frequent visual inspections are recommended to be initially performed for corrosion resistant coated sprinklers, after the installation has been com-



**STENNIS RIVERINE & COMBATANT TRAINING**  
**FACILITY**  
**STENNIS SPACE CENTER**  
**STENNIS, MS 39529**

**FIRE PROTECTION/ SPRINKLER SYSTEMS**  
**OPERATIONS BUILDING 2440/2441**  
**BOAT STORAGE BUILDING 2442**

## **SECTION 2**

# **VALVES & DEVICES**

**SIMPLEXGRINNELL**  
**5800 JEFFERSON HWY., SUITE A**  
**HARAHAN, LA 70123**  
**PHONE: 504-736-0104**  
**FAX: 504-736-9292**

# Reliable®

## Model G 2½" (65mm), 3" (80mm), 4" (100mm) & 6" (150mm) Right-Check™ Riser Valves

### Features

1. Grooved end connections.
2. Compact, lightweight design.
3. Non-slamming, spring loaded clapper to minimize water hammer.
4. Approved for horizontal and vertical installation.
5. Stream-lined body design provides very low friction loss.
6. Elastomer faced clapper provides leak-free, non-sticking sealing.

Reliable Model G Riser Right-Check™ Valves are intended for installation in wet pipe fire protection system risers and preaction systems using supervisory air as low as 1 psi (0,07 bar). The Riser Valve and Trim Kit (Figure 1) with a water flow detector can provide an electric alarm, and is a cost effective alternative to an alarm valve in installations not requiring a mechanical alarm.

Riser Valves are factory tapped for 1¼" (or 2") NPT and ½" NPT system connections and for ¼" NPT supply connection (Ref. Figure 3).

Grooved end connections provide fast and easy installation using listed or approved mechanical grooved couplings. Rigid style grooved couplings can be used for positive clamping to resist flexural and torsional loads.

Riser Right-Check™ Valves and associated riser equipment should periodically be given a thorough inspection and test. NFPA 25 provides minimum maintenance requirements. Check valves should be inspected and operated at least annually. Parts should be replaced as required.

When Model G Riser Valves are installed vertically, the direction of the flow arrow must point upward. For horizontal installations, the hinge pin must be located at the top. In preaction systems, the valves must be installed vertically.

### Valve Description

1. Rated working pressure - 250 psi (17,2 bar).
2. Factory hydrostatic test pressure - 500 psi (34,5 bar).
3. Friction loss, expressed in equivalent length of Sch. 40 pipe with C = 120 (based on Hazen-Williams formula) and a flowing velocity of 15 ft/s (4.6 m/s), is:  
2½" (65mm) - 7 ft. (2.1m)    4" (100mm) - 10 ft. (3.0m)  
3" (80mm) - 7 ft. (2.1m)    6" (150mm) - 16 ft. (4.9m)  
See Bulletin 807 for Pressure Drop (psi) vs. Flow Rate (gpm) data chart.
4. Standard grooved end dimensions per ANSI/AWWA C606.

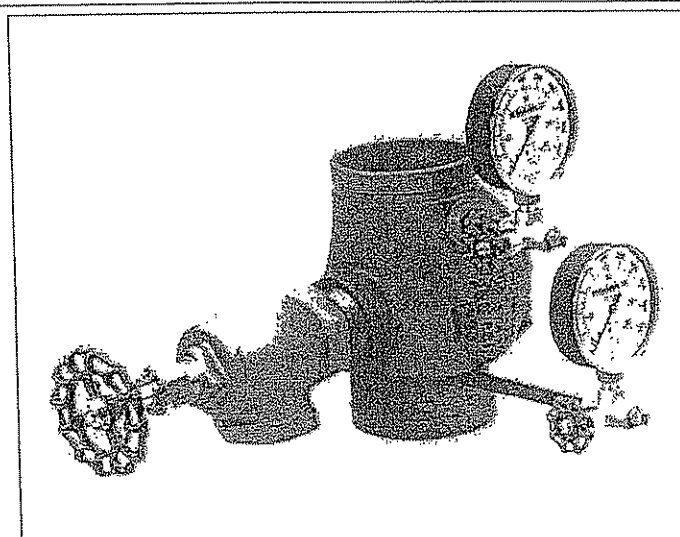


Figure 1

2-1/2" (65mm) Valve:				
A=7.12" (181mm)	B=4.81" (122mm)	C=3.88" (98mm)	D=11.38" (289mm)	E=3.01" (76mm)
3" (80mm) Valve:				
A=7.62" (194mm)	B=5.06" (129mm)	C=4.00" (102mm)	D=11.62" (295mm)	E=3.56" (90mm)
4" (100mm) Valve:				
A=8.44" (214mm)	B=6.19" (157mm)	C=4.00" (102mm)	D=13.56" (344mm)	E=4.12" (105mm)
6" (150mm) Valve:				
A=10.25" (260mm)	B=7.06" (179mm)	C=5.12" (130mm)	D=14.44" (367mm)	E=5.40" (137mm)

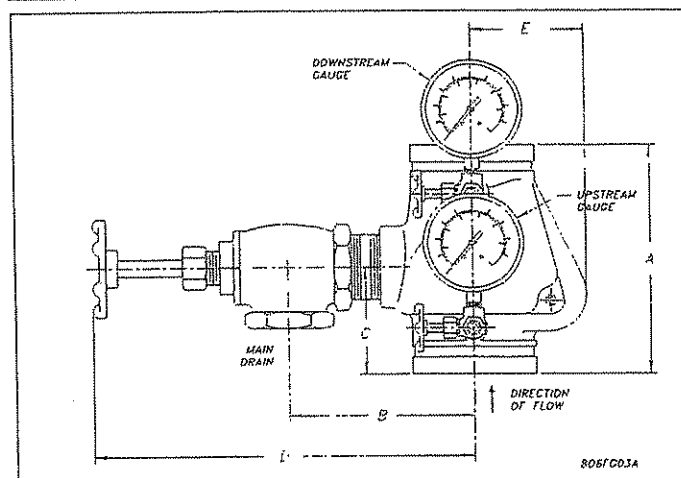


Figure 2

6. Shipping weight (including Trim Kit):  
2½" (65mm) - 14 lbs. (6.4 kg)  
3" (80mm) - 15 lbs. (6.8 kg)  
4" (100mm) - 24 lbs. (11.0 kg)  
6" (150mm) - 45 lbs. (20.4 kg)

Refer to figure 3.

Item No.	Part Name	Material	Quantity	Part Number			
				2½" (65mm)	3" (80mm)	4" (100mm)	6" (150mm)
1*	Valve Body	Gray Iron, ASTM-A48 Class 30A	1	91005002	91005003	91005004	91005006
2*	Seat	Bronze C83600 or C93200, ASTM-B505	1	96020200	96020300	96020400	96020600
3	Clapper	Stainless Steel 304, ASTM-A240	1	91816112	91816113	91816114	91816116
4	Facing Seal **	EPDM Rubber	1	95520200	95520300	95520400	95520600
5	Clamping Ring	Stainless Steel 304, ASTM-A240	1	95290300	95290300	95290400	95290600
6	Gasket **	EPDM Rubber	1	93720302	93720302	93720604	93720604
7	Spring	Stainless Steel 302, ASTM-A313	1	96400300	96400300	96400400	96400600
8	Hinge Pin	Stainless Steel 303, ASTM-A582	1	95000280	95000300	95006824	95000600
9	Bolt	Stainless Steel 304, ASTM-F593	1	91090300	91090300	91090400	91090600
10	Locknut **	Stainless Steel 303, ASTM-F594	1	94911420	94911420	94913816	94913816
11	Plug, ½"NPT	Steel	1	—	—	—	—
**	Replacement Seal Kit		1	6888040025	6888040030	6888040040	6888040060
	Body - Seat Sub - Assembly		1	91005202	91005203	91005204	91005206

\* Not field replaceable.

### Trim Kit Description

#### Main Drain:

- 1¼" (32mm) angle valve and close nipple, 2½" and 3" (65mm and 80mm) sizes.
- 2" (50mm) angle valve and close nipple, 4" and 6" (100mm and 150mm) sizes.

#### Upstream and Downstream Side (all sizes):

- 300 psi (20,7 bar) water pressure gauge (2 req'd).
- ¼" (6mm) 3-way globe valve (2 req'd).
- ¼" x 5" (6mm x 127mm) nipple (upstream only).
- ¼" x 1½" (6mm x 38mm) nipple (downstream only).
- ¼" (6mm) plug (2 req'd).

### Approvals

1. Listed by Underwriters Laboratories, Inc.
2. Listed by Underwriters Laboratories of Canada.
3. Approved by Factory Mutual Research Corp.
4. NYC MEA 258-93E.

### Valve Disassembly (Refer to figure 3)

1. Close the main water supply valve and drain the system.
2. Remove the check valve from the piping system.
3. Inspect the Seat (2) for any cuts, scrapes and dents. Replace the valve if any damage is found.
4. To replace the Facing Seal (4), remove the Clapper (3), unscrew the Locknut (10) and remove the retention Bolt (9).

### Valve Reassembly (Refer to figure 3)

1. Thoroughly clean the Clapper (3). Insert the retention Bolt (9) with a new Gasket (6).
2. Place the new Facing Seal (4) and the Clamping Ring (5) against the Clapper (3). Tighten the new Locknut (10) to 21 in. lbs. (2.3 Nm) torque in 2½" (65mm) and 3" (80mm) sizes and to 52 in. Lbs. (5.7 Nm) in 4" (100mm) and 6" (150mm) sizes.

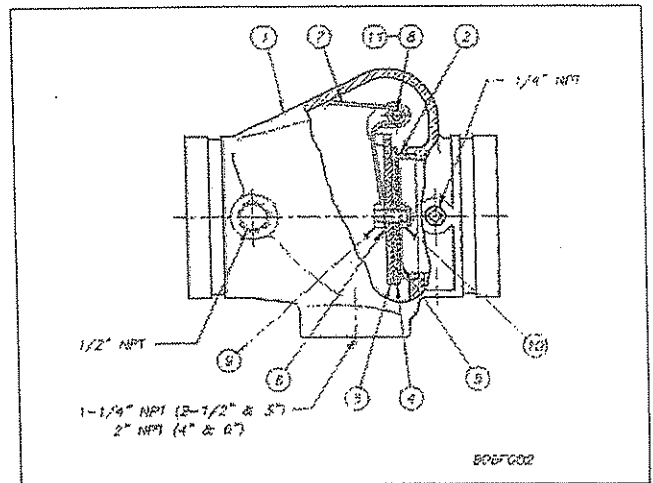


Figure 3

3. Insert the clapper assembly into the valve through the downstream opening. Reinsert the Hinge Pin (8) while holding the coils of the properly oriented Spring (7) in place. Install the Hinge Pin Plug (11).
4. Reinstall the check valve in the system.
5. Place the system back in service.

### Ordering Information

#### Specify:

1. Model G Riser Valve.
2. Size.
3. Riser Trim Kit (ordered separately), specify valve size.

Contact the installing contractor or Reliable if any difficulties are experienced. Should replacement parts be needed, use only genuine Reliable parts.

The equipment presented in this bulletin is to be installed in accordance with the latest pertinent Standards of the National Fire Protection Association, Factory Mutual Research Corporation, or other similar organizations and also with the provisions of governmental codes or ordinances whenever applicable.

Products manufactured and distributed by Reliable have been protecting life and property for over 80 years, and are installed and serviced by the most highly qualified and reputable sprinkler contractors located throughout the United States, Canada and foreign countries.



The Reliable Automatic Sprinkler Co., Inc.

(800) 431-1588  
 (800) 848-6051  
 (914) 829-2042  
 www.reliablesprinkler.com

Sales Offices  
 Sales Fax  
 Corporate Offices  
 Internet Address

Revision lines indicate updated or new data.  
 EG. Printed in USA 03/09 P/N 999970070

# Reliable®

## Model CR Commercial Riser Riser Manifold for Commercial Applications

### Available Sizes/Pressure Ratings:

4"(100mm), 6"(150mm), and 8"(200mm) Grooved  
- 300 psi (20,7 bar) Working Pressure

### Features

1. Cast stainless steel body construction for threaded manifolds.
2. Painted, cast ductile iron body construction for grooved manifolds.
3. Brass and galvanized Trim.
4. Factory assembled and pressure tested.
5. Available with TestANDrain® Valve in various orifice sizes.
6. Optional Pressure Relief Valve Kit available for all sizes.
7. Same end-to-end dimensions for the 4"(100mm) through 8"(200mm) grooved sizes.
8. Approved for installation in horizontal or vertical positions.
9. Built in drain port allows hydrostatic testing without draining the system.
10. 1/4" three-way valve allows for easy testing and replacing of pressure gauge.
11. Dedicated UL Listed, ULC Listed and FM Approved Waterflow Detector assures optimum sensitivity. See Table 3 for triggering flow rates.

### Product Description

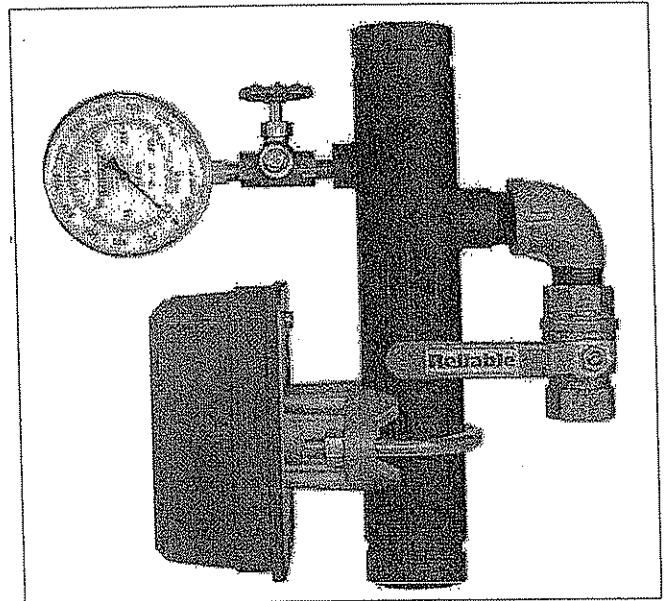
The Model CR Commercial Riser comes factory assembled with the necessary accessories for a cost effective, yet complete riser assembly. These assemblies are UL Listed and FM Approved as a unit.

Cast-on lettering on the manifold identifies manifold pipe size, flow direction, gauge and drain outlets, and UL Listing and FM Approval markings.

The Model CR Commercial Riser is available in four configurations (see Figures 1 and 2):

#### • Basic Trim

Commercial riser manifold assembly includes a cULus Listed pressure gauge, a 1/4" three-way valve, a drain (ball) valve, and a dedicated waterflow detector containing two sets of SPDT (Form C) contacts, having an electrical rating of 10A @ 125/250 VAC/2.5 A @ 24 VDC. (8" only: 15A @ 125/250 VAC/2.0 A @ 24 VDC). See Table 3 for triggering flow rates.



#### • Basic Trim with Pressure Relief Kit

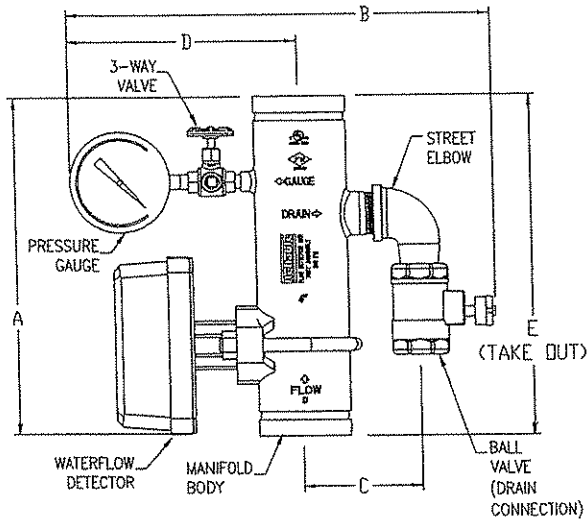
Commercial riser manifold assembly includes a cULus Listed pressure gauge, a 1/4" three-way valve, a drain (ball) valve, and a dedicated waterflow detector containing two sets of SPDT (Form C) contacts, having an electrical rating of 10A @ 125/250 VAC/2.5 A @ 24 VDC. (8" only: 15A @ 125/250 VAC/2.0 A @ 24 VDC). See Table 3 for triggering flow rates. The non-adjustable Pressure Relief Kit will maintain system pressures below 175 psi (12,1 bar).

#### • Basic Trim with TestANDrain® Valve

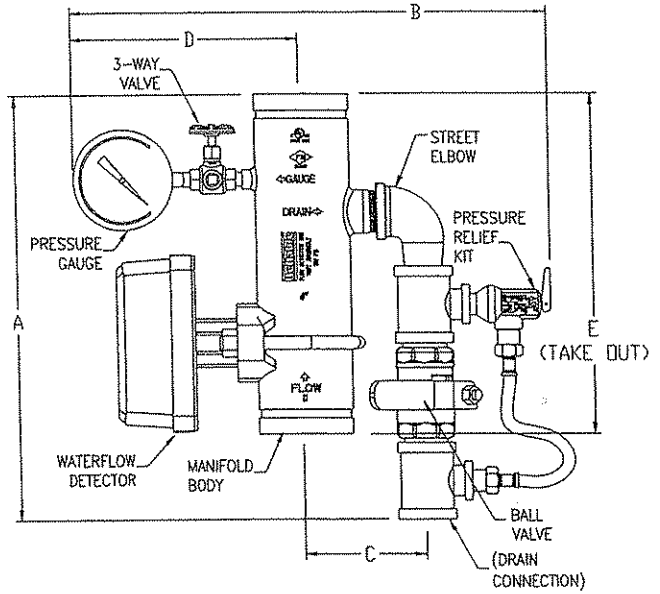
Commercial riser manifold assembly includes a cULus Listed pressure gauge, a 1/4" three-way valve, a TestANDrain® Valve, and a dedicated waterflow detector containing two sets of SPDT (Form C) contacts, having an electrical rating of 10A @ 125/250 VAC/2.5 A @ 24 VDC. (8" only: 15A @ 125/250 VAC/2.0 A @ 24 VDC). See Table 3 for triggering flow rates. The available test orifice sizes inside the TestANDrain® Valve are (choose one):

- 7/16"(11mm)(not FM Approved)
- 1/2"(15mm)
- 17/32 (20mm)
- ELO
- ESFR

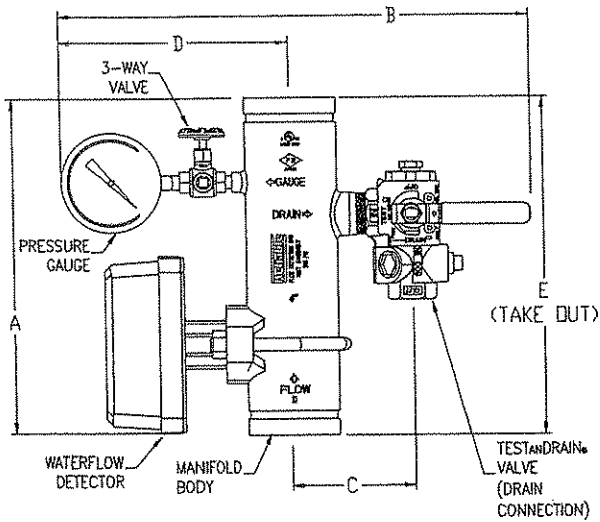
GROOVED ENDS ASSEMBLIES (4"(100MM), 6"(150MM), & 8"(200MM))



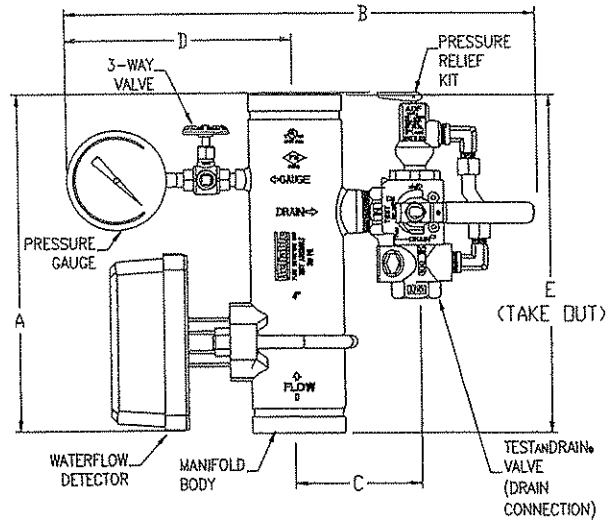
BASIC ASSEMBLY (4" (100MM) VERSION SHOWN)  
SEE TABLE 1.



BASIC ASSEMBLY WITH PRESSURE RELIEF KIT  
(4" (100MM) VERSION SHOWN) SEE TABLE 1.



BASIC ASSEMBLY WITH TEST AND DRAIN VALVE  
(4" (100MM) VERSION SHOWN) SEE TABLE 2.



BASIC ASSEMBLY WITH TEST AND DRAIN VALVE  
& PRESSURE RELIEF KIT  
(4" (100MM) VERSION SHOWN) SEE TABLE 2.

615FG02C

Figure 1

Table 1

		Dimensions & Weights											
		Basic Assembly						Basic Assembly with Pressure Relief Kit					
Grooved Ends (See Fig. 1)	Manifold Pipe Size in (mm)	A in (mm)	B in (mm)	C in (mm)	D in (mm)	E in (mm)	Weight lbs (kg)	A in (mm)	B in (mm)	C in (mm)	D in (mm)	E in (mm)	Weight lbs (kg)
	4 (100)	12.5 (318)	18 (457)	5.25 (133)	9 (229)	13 (330)	21.3 (9.7)	16.75 (425)	18.5 (470)	6 (152)	9 (229)	13 (330)	26.7 (12)
	6 (150)	12.5 (318)	20 (508)	6.25 (159)	10 (254)	13 (330)	26.3 (12)	16.75 (425)	20.5 (521)	7 (178)	10 (254)	13 (330)	31.8 (14.4)
	8 (200)	12.5 (318)	22 (559)	7.25 (184)	11 (280)	13 (330)	31 (14.1)	16.75 (425)	22.5 (572)	8 (203)	11 (280)	13 (330)	36.5 (16.6)

Table 2

		Dimensions & Weights											
		Basic Assembly with TestANDrain® Valve						Basic Assembly with TestANDrain® Valve & Pressure Relief Kit					
Grooved Ends (See Fig. 1)	Manifold Pipe Size in (mm)	A in (mm)	B in (mm)	C in (mm)	D in (mm)	E in (mm)	Weight lbs (kg)	A in (mm)	B in (mm)	C in (mm)	D in (mm)	E in (mm)	Weight lbs (kg)
	4 (100)	12.5 (318)	23.5 (597)	6 (152)	9 (229)	13 (330)	25.6 (11.6)	12.5 (318)	23.5 (597)	6 (152)	9 (229)	13 (330)	26 (11.8)
	6 (150)	12.5 (318)	25.5 (648)	7 (178)	10 (254)	13 (330)	30 (13.6)	12.5 (318)	25.5 (648)	7 (178)	10 (254)	13 (330)	31 (14.1)
	8 (200)	12.5 (318)	27.5 (699)	8 (203)	11 (280)	13 (330)	35.3 (16)	12.5 (318)	27.5 (699)	8 (203)	11 (280)	13 (330)	36.3 (16.5)

#### • Basic Trim with TestANDrain® Valve & Pressure Relief Kit

Commercial riser manifold assembly includes a cULus Listed pressure gauge, a ¼" three-way valve, a TestANDrain® Valve, and a dedicated waterflow detector containing two sets of SPDT (Form C) contacts, having an electrical rating of 10A @ 125/250 VAC/2.5 A @ 24 VDC. (8" only: 15A @ 125/250 VAC/2.0 A @ 24 VDC ). See Table 3 for triggering flow rates. The non-adjustable Pressure Relief Kit will maintain system pressures below 175 psi (12,1 bar). The available test orifice sizes inside the TestANDrain® Valve are (choose one):

- 7/16"(11mm)(not FM Approved)
- 1/2"(15mm)
- 17/32 (20mm)
- ELO
- ESFR.

#### Installation

1. Attach the pressure gauge as shown in Figures 1-4.
2. Install the manifold with the flow arrow pointing towards the SYSTEM side using threaded fittings or grooved pipe couplings.
3. Connect the appropriately sized drain line. Ensure that the drain valve is in the CLOSED position.

4. Place the sprinkler system in service.
5. Installation must comply with NFPA 13, Section 8.16.4.2

#### Caution:

Automatic sprinkler systems having non-fire protection connection (permitting continual water flow) require dielectric fittings, according to NFPA 13 sect. 4-6, when dissimilar metal piping materials are joined.

#### Note:

Use a non-hardening pipe joint compound, or teflon tape. Follow the manufacturer's instructions when using grooved pipe couplings.

#### Listings and Approvals

1. Listed by Underwriters' Laboratories Inc. and UL certified for Canada (cULus).
2. Factory Mutual Approved.
3. NYC MEA 258-93-E

## Engineering Specification

[Model CR Commercial Riser Assembly] shall be [cULus Listed] [Factory Mutual (FM) Approved] for horizontal or vertical installation as a one-piece, fabricated assembled unit. The [Model CR Commercial Riser Assembly] shall consist of a (choose one):

- 4" (100 mm) cast, non-welded, ductile iron body with grooved end connections
- 6" (150 mm) cast, non-welded ductile iron body with grooved end connections
- 8" (200 mm) cast, non-welded, ductile iron body with grooved end connections

having all brass and galvanized trim. The manifold piping shall clearly identify the manifold's pipe size, flow direction, cULus Listing/FM Approval, drain, and gauge outlets. A built-in drain port shall be available to permit hydrostatic testing without draining the system. This drain port shall be sized per the following:

- 4" (100mm), 6" (150mm), and 8" (200mm) sizes

End-to-end dimensions shall be the same for the 4" (100mm) through 8" (200mm) grooved sizes. Assembly shall have a working pressure rating of [300 psi (20,7 bar) (for 4" through 8" grooved manifold assemblies)].

**Table 3**

Manifold Sizes	Triggering Flow Rate - GPM (LPM)
4" (100mm), 6" (150mm), 8" (200mm)	4 (15) to 10 (38)

## Ordering Information:

### Model CR Commercial Riser Assembly Part Number Code Key

<b>4G</b> <b>6G</b> <b>8G</b>	<b>B</b> <b>T716**</b> <b>T12</b> <b>T1732</b> <b>TELO</b> <b>TESFR*</b>	<b>0</b> <b>1</b> <b>2</b> <b>3</b>
4G = 4" (100 mm) Grooved Ends Assembly 6G = 6" (150 mm) Grooved Ends Assembly 8G = 8" (200 mm) Grooved Ends Assembly	B = Basic Assembly T716 = w/ 7/16" (11 mm) Orif. Test&Drain Valve T12 = w/ 1/2" (15 mm) Orif. Test&Drain Valve T1732 = w/ 17/32" (20 mm) Orif. Test&Drain Valve TELO = w/ELO Orif. TESFR = w/ESFR Orif. ** 7/16" (11 mm) orifice is not FM Approved	0 = Assembly without Pressure Relief Kit Water Detector UL & FM 1 = Assembly with Pressure Relief Kit Water Detector UL & FM 2 = Assembly without Pressure Relief Kit Water Detector UL C 3 = Assembly with Pressure Relief Kit Water Detector UL C

### Example #1: 6G – 1732 – 0

(6" (150mm) Model CR Commercial Riser Assembly with grooved ends, basic trim with Test&Drain<sup>®</sup> Valve having a 17/32" diameter test orifice, without a Pressure Relief Kit)

#### Notes:

1. All Model CR Commercial Riser Assemblies come with a 300 psi (20,7 bar) UL Listed and FM Approved pressure gauge for 175 psi (12,1 bar) applications. If the Model CR Commercial Riser Assembly is to be installed in a 300 psi (20,7 bar) application, please purchase a 600 psi (41,4 bar) (P/N 98248005) pressure gauge. This gauge may or may not be UL Listed and/or FM Approved at the time of purchase.
2. If required, Pressure Relief Kits may also be installed in the field. Please contact Reliable's Customer Service Department for details.

The equipment presented in this bulletin is to be installed in accordance with the latest pertinent Standards of the National Fire Protection Association, Factory Mutual Research Corporation, or other similar organizations and also with the provisions of governmental codes or ordinances whenever applicable.

Products manufactured and distributed by Reliable have been protecting life and property for over 80 years, and are installed and serviced by the most highly qualified and reputable sprinkler contractors located throughout the United States, Canada and foreign countries.

Manufactured by

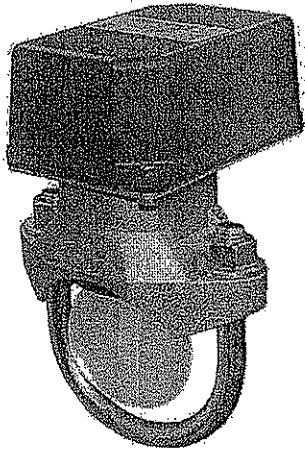


The Reliable Automatic Sprinkler Co., Inc.  
 (800) 431-1588 Sales Offices  
 (800) 848-6051 Sales Fax  
 (914) 829-2042 Corporate Offices  
 www.reliablesprinkler.com Internet Address



Revision lines indicate updated or new data.

E. G. Printed in U.S.A. 06/08 P/N 9999970259



UL, CUL and CSFM Listed, FM Approved, LPCB Approved, For CE Marked (EN12259-5) / VdS Approved model use VSR-EU

Service Pressure: 450 PSI (31 BAR) - UL

Flow Sensitivity Range for Signal:

4-10 GPM (15-38 LPM) - UL

Maximum Surge: 18 FPS (5.5 m/s)

Contact Ratings: Two sets of SPDT (Form C)

10.0 Amps at 125/250VAC

2.0 Amps at 30VDC Resistive

10 mAmps min. at 24VDC

Conduit Entrances: Two knockouts provided for 1/2" conduit.

Individual switch compartments suitable for dissimilar voltages.

Environmental Specifications:

- NEMA 4/IP54 Rated Enclosure suitable for indoor or outdoor use with factory installed gasket and die-cast housing when used with appropriate conduit fitting.
- Temperature Range: 40°F - 120°F, (4.5°C - 49°C) - UL
- Non-corrosive sleeve factory installed in saddle.

Service Use:

Automatic Sprinkler

NFPA-13

One or two family dwelling

NFPA-13D

Residential occupancy up to four stories

NFPA-13R

National Fire Alarm Code

NFPA-72

Optional: Cover Tamper Switch Kit, stock no. 0090148

Replaceable Components: Retard/Switch Assembly, stock no. 1029030

**WARNING**

- Installation must be performed by qualified personnel and in accordance with all national and local codes and ordinances.
- Shock hazard. Disconnect power source before servicing. Serious injury or death could result.
- Risk of explosion. Not for use in hazardous locations. Serious injury or death could result.

**General Information**

The Model VSR is a vane type waterflow switch for use on wet sprinkler systems. It is UL Listed and FM Approved for use on steel pipe; schedules 10 through 40, sizes 2" thru 8" (50 mm thru 200 mm). LPC approved sizes are 2" thru 8" (50 mm thru 200 mm). See Ordering Information chart.

The VSR may also be used as a sectional waterflow detector on large systems.

The VSR contains two single pole, double throw, snap action switches and an adjustable, instantly recycling pneumatic retard. The switches are actuated when a flow of 10 GPM (38 LPM) or more occurs downstream of the device. The flow condition must exist for a period of time necessary to overcome the selected retard period.

**Enclosure**

The VSR switches and retard device are enclosed in a general purpose, die-cast housing. The cover is held in place with two tamper resistant screws which require a special key for removal. A field installable cover tamper switch is available as an option which may be used to indicate unauthorized removal of the cover. See bulletin number 5401103 for installation instructions of this switch.

**Installation (See Fig. 1)**

These devices may be mounted on horizontal or vertical pipe. On horizontal pipe they should be installed on the top side of the pipe where they will be accessible. The device should not be installed within 6" (15 cm) of a fitting which changes the direction of the waterflow or within 24" (60 cm) of a valve or drain.

*Note:* Do not leave cover off for an extended period of time.

Drain the system and drill a hole in the pipe using a hole saw in a slow speed drill. (see Fig. 1)

Clean the inside pipe of all growth or other material for a distance equal to the pipe diameter on either side of the hole.

Roll the vane so that it may be inserted into the hole; do not bend or crease it. Insert the vane so that the arrow on the saddle points in the direction of the waterflow. Install the saddle strap and tighten nuts alternately to required torque. (see Fig. 1). The vane must not rub the inside of the pipe or bind in any way.

Specifications subject to change without notice.

Ordering Information			
Nominal Pipe Size		Model	Part Number
2"	DN50	VSR-2	1144402
2 1/2"	DN65	VSR-2 1/2	1144425
3"	DN80	VSR-3	1144403
3 1/2"	-	VSR-3 1/2	1144435
4"	DN100	VSR-4	1144404
5"	-	VSR-5	1144405
6"	DN150	VSR-6	1144406
8"	DN200	VSR-8	1144408

Fig. 1

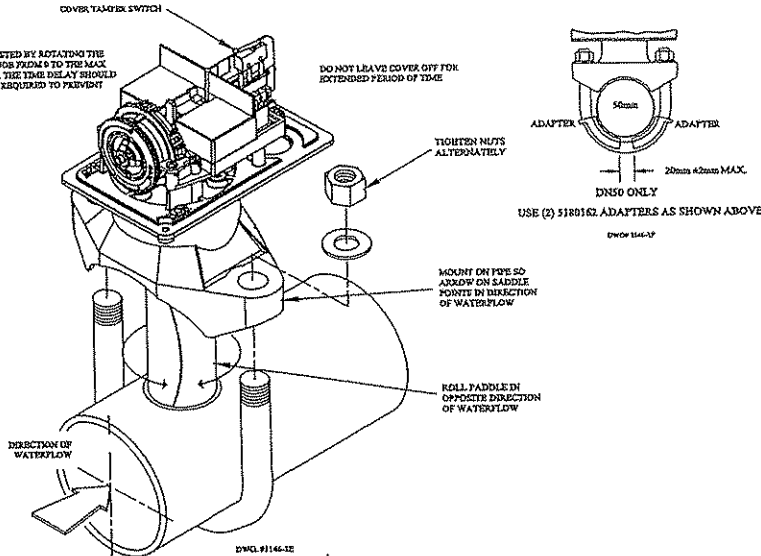
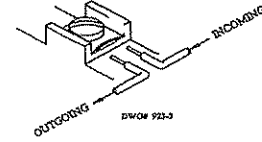


Fig. 2 Switch Terminal Connections  
Clamping Plate Terminal



**WARNING**

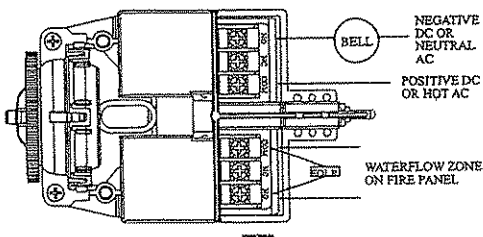
An uninsulated section of a single conductor should not be looped around the terminal and serve as two separate connections. The wire must be severed, thereby providing supervision of the connection in the event that the wire become dislodged from under the terminal. Failure to sever the wire may render the device inoperable risking severe property damage and loss of life.

**CAUTION**

Waterflow switches that are monitoring wet pipe sprinkler systems shall not be used as the sole initiating device to discharge AFFF, deluge, or chemical suppression systems. Waterflow switches used for this application may result in unintended discharges caused by surges, trapped air, or short retard times.

Installation Requirements								
Model	Nominal Pipe Size		Nominal Pipe O.D.		Hole Size		U-Bolt Nuts Torque	
	inch	mm	inch	mm	inch	mm	ft-lb	n-m
VSR-2	2	DN50	2.375	60.3	1.25 + .125/- .062	33.0 ± 2.0	20	27
VSR-2 1/2	2 1/2		2.875	73.0				
VSR-2 1/2	2 1/2	DN65	3.000	76.1				
VSR-3	3	DN80	3.500	88.9	2.00 ± .125	50.8 ± 2.0		
VSR-3 1/2	3 1/2		4.000	101.6				
VSR-4	4	DN100	4.500	114.3				
VSR-5	5		5.563	141.3				
VSR-6	6	DN150	6.625	168.3				
VSR-8	8	DN200	8.625	219.1				

Fig. 3 Typical Electrical Connections



Notes:

1. The Model VSR has two switches, one can be used to operate a central station, proprietary or remote signaling unit, while the other contact is used to operate a local audible or visual annunciator.
2. A condition of LPC Approval of this product is that the electrical entry must be sealed to exclude moisture.
3. For supervised circuits see "Switch Terminal Connections" drawing and caution note (Fig. 2).

Fig. 4

Break out thin section of cover when wiring both switches from one conduit entrance.

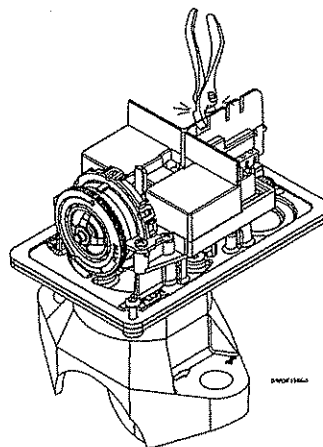
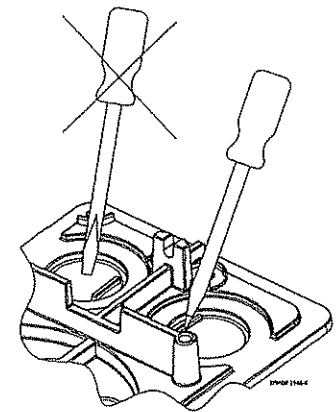


Fig. 5

To remove knockouts: Place screwdriver at inside edge of knockouts, not in the center.



Model	Nominal Pipe Size		Nominal Pipe O.D.		Pipe Wall Thickness							
					Schedule 10 (UL)		Schedule 40 (UL)		BS-1387 (LPC)		DN (VDS)	
	inch	mm	inch	mm	inch	mm	inch	mm	inch	mm	inch	mm
VSR-2	2	DN50	2.375	60.3	0.109	2.77	0.154	3.91	0.142	3.6	0.091	2.3
VSR-2 1/2	2 1/2		2.875	73.0	0.120	3.05	0.203	5.16				
VSR-2 1/2		DN65	3.000	76.1					0.142	3.6	0.102	2.6
VSR-3	3	DN80	3.500	88.9	0.120	3.05	0.216	5.49	0.157	4.0	0.114	2.9
VSR-3 1/2	3 1/2		4.000	101.6	0.120	3.05	0.226	5.74				
VSR-4	4	DN100	4.500	114.3	0.120	3.05	0.237	6.02	0.177	4.5	0.126	3.2
VSR-5	5		5.563	141.3	0.134	3.40	0.258	6.55				
VSR-6	6	DN150	6.625	168.3	0.134	3.40	0.280	7.11	0.197	5.0	0.157	4.0
VSR-8	8	DN200	8.625	219.1	0.148	3.76	0.322	8.18	0.248	6.3	0.177	4.5

Note: For copper or plastic pipe use Model VSR-CF.

**Testing**

The frequency of inspection and testing for the Model VSR and its associated protective monitoring system should be in accordance with applicable NFPA Codes and Standards and/or the authority having jurisdiction (manufacturer recommends quarterly or more frequently).

If provided, the inspector's test valve, that is usually located at the end of the most remote branch line, should always be used for test purposes. If there are no provisions for testing the operation of the flow detection device on the system, application of the VSR is not recommended or advisable. A minimum flow of 10 GPM (38 LPM) is required to activate this device.

**Maintenance**

Inspect detectors monthly for leaks. If leaks are found, replace the detector. The VSR waterflow switch should provide years of trouble-free service. The retard and switch assembly are easily field replaceable. In the unlikely event that either component does not perform properly, please order replacement retard switch assembly stock #1029030. There is no maintenance required, only periodic testing and inspection.

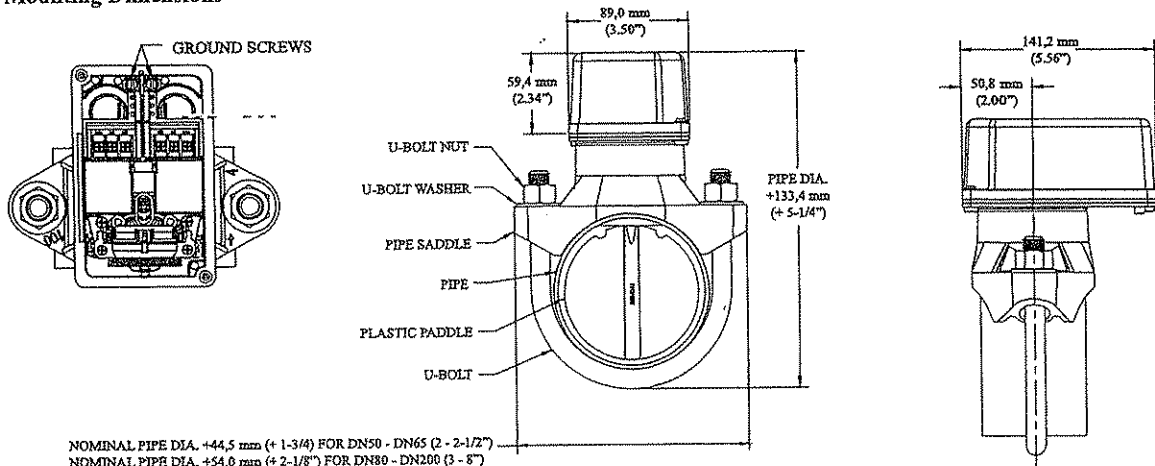
**Removal**

- To prevent accidental water damage, all control valves should be shut tight and the system completely drained before waterflow detectors are removed or replaced.
- Turn off electrical power to the detector, then disconnect wiring.
- Loosen nuts and remove U-bolts.
- Gently lift the saddle far enough to get your fingers under it. With your fingers, roll the vane so it will fit through the hole while continuing to lift the waterflow detector saddle.
- Lift detector clear of pipe.

**Important Notice**

Please advise the person responsible for testing of the fire protection system that this system must be tested in accordance with the testing instructions.

**Mounting Dimensions**



DWG# 1146-6

## Model BFV-N Butterfly Valve Grooved End 2-1/2 Inch - 10 Inch (DN65 - DN250)

### General Description

The Model BFV-N Grooved End Butterfly Valves (Ref. Figure 1) are indicating type valves designed for use in fire protection systems where a visual indication is required as to whether the valve is open or closed. They are used, for example, as system, sectional, and pump water control valves. They have cut groove inlet and outlet connections that are suitable for use with grooved end pipe couplings that are listed and approved for fire protection systems.

For applications requiring supervision of the open position of the valve, the Gear Operators for the Model BFV-N Butterfly Valves are provided with two sets of factory installed internal switches each having SPDT contacts. The supervisory switches transfer their electrical contacts when there is movement from the valve's normal open position during the first two revolutions of the handwheel.

#### WARNINGS

*The Model BFV-N Grooved End Butterfly Valves described herein must be installed and maintained in compliance with this document, as well as with the applicable standards of the National Fire Protection Association, in addition to the standards of any other authorities having jurisdiction. Failure to do so may impair the performance of these devices.*

*The owner is responsible for maintaining their fire protection system and devices in proper operating condition. The installing contractor or sprinkler manufacturer should be contacted with any questions.*

### Technical Data

#### Model BFV-N

**Sizes:** ANSI Inches / DN  
2-1/2 (DN65), 3 (DN80),  
4 (DN100), 5 (DN125),  
6 (DN150), 8 (DN200), 10 (DN250)

#### Approvals

The 2-1/2 through 10 inch (DN65 - DN250) Model BFV-N Grooved End Butterfly Valves are UL and C-UL Listed and FM Approved.

In addition, the Model BFV-N Grooved End Butterfly Valves are listed by the California State Fire Marshall under Listing No. 7770-1670:100.

All laboratory listings and approvals are for indoor and outdoor use.

#### Maximum Working Pressure

- 2-1/2 - 8 inch (DN65 - DN200):  
300 psi (20,7 bar)
- 10 inch (DN250):  
175 psi (12,0 bar)

#### Materials of Construction:

##### Body

Ductile iron conforming to ASTM A-395

##### Body Coating

Polyamide

##### Disc

Ductile iron conforming to ASTM A-395

##### Disc Seal

Grade EPDM "E" encapsulated rubber conforming to ASTM D-2000

##### Upper & Lower Stem

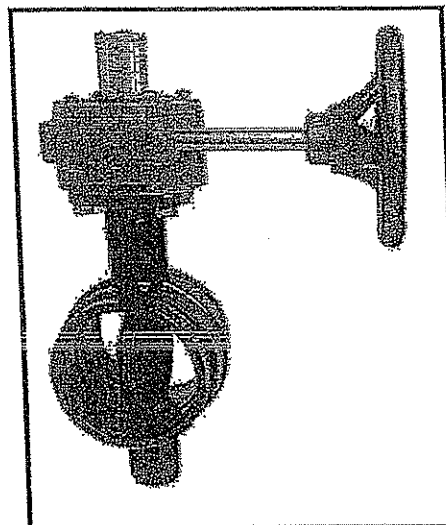
Type 416 Stainless Steel conforming to ASTM 582

##### Lower Plug

PVC

##### Operator

Gear operator with iron housing

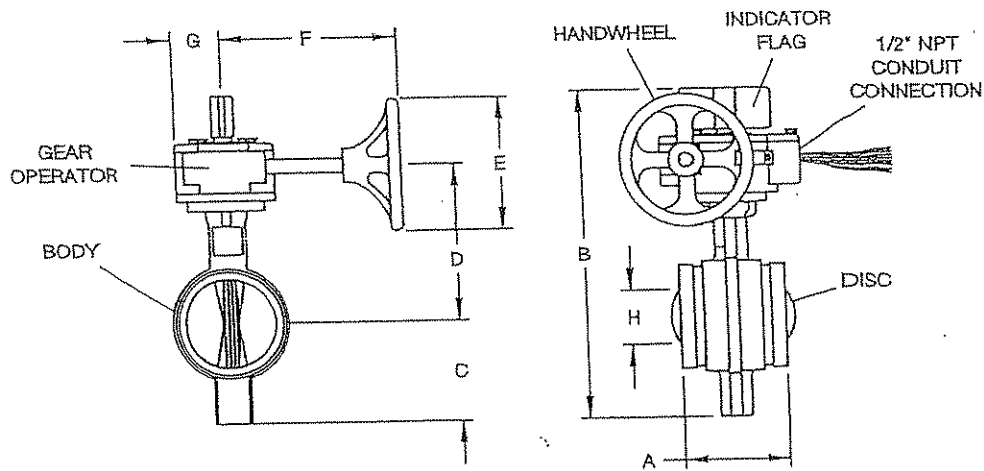


#### Friction Loss

The approximate friction loss, based on the Hazen Williams formula and expressed in equivalent length of pipe with C= 120, is as follows. The data is based on friction loss information collected at a typical flow rate of 15 feet per second.

- 6.9 feet of 2-1/2 inch Sch. 40 pipe for the 2-1/2 inch valve.
- 8.7 feet of 3 inch Sch. 40 pipe for the 3 inch valve.
- 4.5 feet of 4 inch Sch. 40 pipe for the 4 inch valve.
- 6.6 feet of 5 inch Sch. 40 pipe for the 5 inch valve.
- 11.1 feet of 6 inch Sch. 40 pipe for the 6 inch valve.
- 10.2 feet of 8 inch Sch. 30 pipe for the 8 inch valve.
- 12.1 feet of 10 inch Sch. 30 pipe for the 10 inch valve.

Nominal Valve Sizes	Pipe O.D.	Nominal Installation Dimensions in Inches and (mm)								Weight lbs. (kg)
		A	B	C	D	E	F	G	H	
2-1/2" DN65	2.88 (73,0)	3.85 (98,0)	11.71 (297,4)	3.25 (83,0)	5.43 (137,9)	6.00 (152,4)	7.81 (198,4)	2.50 (63,5)	0	22 (10,0)
3" DN80	3.50 (88,9)	3.85 (98,0)	12.25 (311,1)	3.54 (90,0)	5.68 (144,2)	6.00 (152,4)	7.81 (198,4)	2.50 (63,5)	0	23 (10,4)
4" DN100	4.50 (114,3)	4.56 (116,0)	13.95 (354,3)	4.35 (110,0)	6.58 (167,1)	6.00 (152,4)	7.81 (198,4)	2.50 (63,5)	0	28 (12,7)
5" DN125	5.56 (141,3)	5.86 (149,0)	14.93 (379,2)	4.84 (123,0)	7.07 (179,6)	6.00 (152,4)	7.81 (198,4)	2.50 (63,5)	0	31 (14,1)
6" DN150	6.63 (168,3)	5.86 (149,0)	17.31 (439,7)	5.93 (151,0)	8.35 (212,0)	6.00 (152,4)	7.81 (198,4)	2.50 (63,5)	0.67 (17,0)	41 (18,6)
8" DN200	8.63 (219,1)	5.26 (134,0)	19.20 (487,7)	6.87 (174,0)	9.29 (236,0)	6.00 (152,4)	7.81 (198,4)	2.50 (63,5)	5.86 (148,8)	53 (24,1)
10" DN250	10.75 (273,1)	6.29 (160,0)	25.11 (637,8)	9.17 (233,0)	11.50 (292,1)	9.00 (228,6)	7.68 (195,1)	3.00 (76,2)	7.41 (188,2)	88 (40,0)



**FIGURE 1**  
**MODEL BFV-N GROOVED END BUTTERFLY VALVE**  
**- NOMINAL DIMENSIONS -**

## Installation

The Model BFV-N Grooved End Butterfly Valves may be installed with flow in either direction and can be positioned either horizontally or vertically.

The grooved end pipe couplings used with the Model BFV-N must be listed or approved for fire protection service and installed in accordance with the manufacturers instructions.

The Model BFV-N Butterfly Valve may be installed with any schedule of pressure class of pipe or tubing that is listed or approved for fire protection.

As applicable, refer to Figure 2 for the internal switch wiring diagram.

Conduit and electrical connections are to be made in accordance with the authority having jurisdiction and/or the National Electrical Code. With reference to Figure 2, the "supervisory switch" is intended for connection to the supervisory circuit of a fire alarm control panel in accordance with NFPA 72. The "auxiliary switch" is intended for the unsupervised connection to auxiliary equipment in accordance with NFPA 70, National Electric Code.

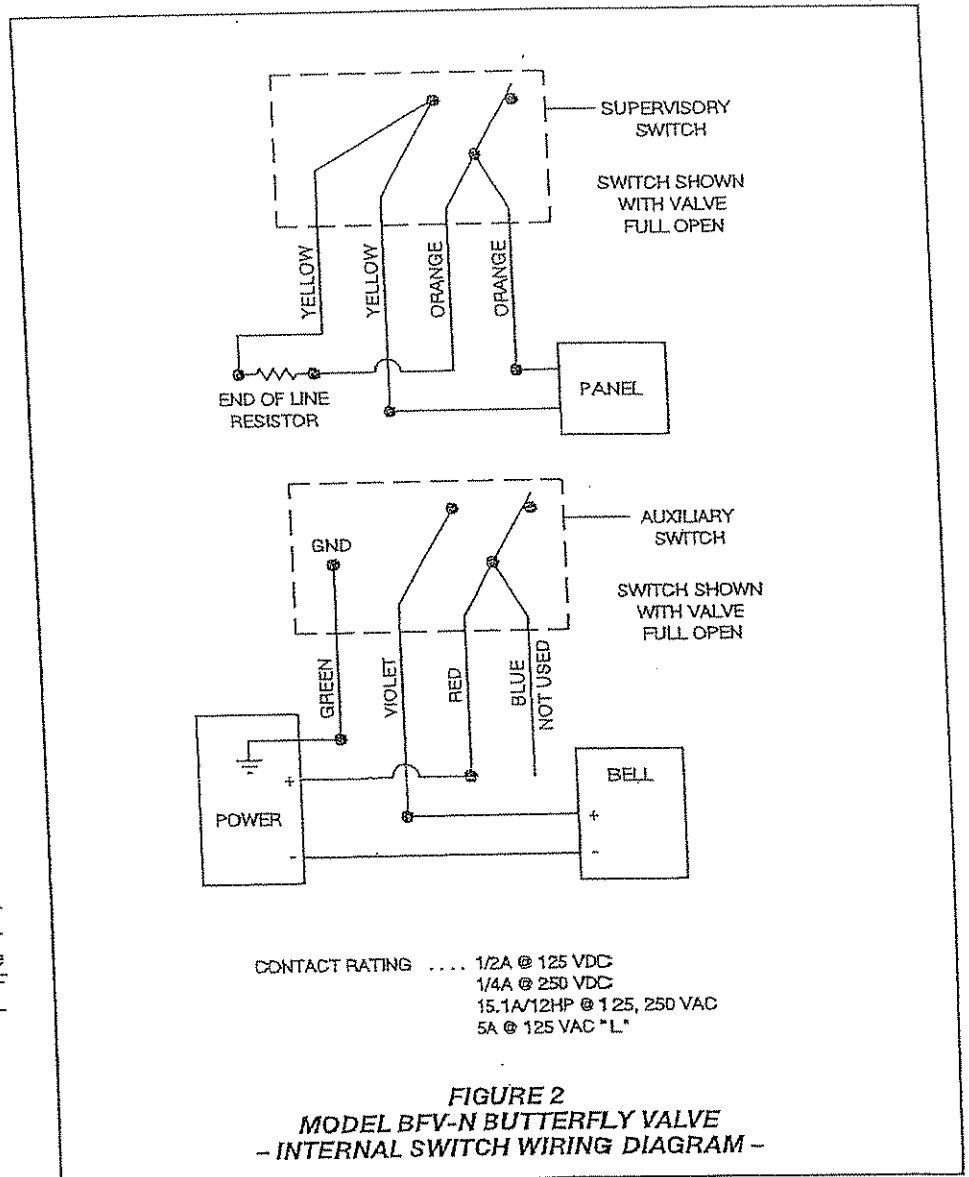
### NOTE

For outdoor applications with internal supervisory switches, it is recommended that wiring connections be made at a temperature above 15°F (-9°C), in order to insure sufficient flexibility of the wire lead insulation.

## Care and Maintenance

The owner is responsible for the inspection, testing, and maintenance of their fire protection system and devices in accordance with the applicable standards of the National Fire Protection Association (e.g., NFPA25), in addition to the standards of any authority having jurisdiction. The installing contractor or product manufacturer should be contacted relative to any questions. Any impairment must be immediately corrected.

It is recommended that automatic sprinkler systems be inspected, tested, and maintained by a qualified inspection service.



### NOTE

Before closing a fire protection system control valve for maintenance or inspection work on either the valve or fire protection system which it controls, permission to shut down the affected fire protection systems must be obtained from the proper authorities and all personnel who may be affected by this decision must be notified.

## Limited Warranty

Products manufactured by Tyco Fire & Building Products (TFBP) are warranted solely to the original Buyer for ten (10) years against defects in material and workmanship when paid for and properly installed and maintained under normal use and service. This warranty will expire ten (10) years from date of shipment by TFBP. No warranty is given for products or components manufactured by companies not affiliated by ownership with TFBP or for products and components which have been subject to misuse, improper installation, corrosion, or which have not been installed, maintained, modified or repaired in accordance with applicable Standards of the National Fire Protection Association, and/or the standards of any other Authorities Having Jurisdiction. Materials found by TFBP to be defective shall be either repaired or replaced, at TFBP's sole option. TFBP neither assumes, nor authorizes any person to assume for it, any other obligation in connection with the sale of products or parts of products. TFBP shall not be responsible for sprinkler system design errors or inaccurate or incomplete information supplied by Buyer or Buyer's representatives.

In no event shall TFBP be liable, in contract, tort, strict liability or under any other legal theory, for incidental, indirect, special or consequential damages, including but not limited to labor charges, regardless of whether TFBP was informed about the possibility of such damages, and in no event shall TFBP's liability exceed an amount equal to the sales price.

The foregoing warranty is made in lieu of any and all other warranties, express or implied, including warranties of merchantability and fitness for a particular purpose.

This limited warranty sets forth the exclusive remedy for claims based on failure of or defect in products, materials or components, whether the claim is made in contract, tort, strict liability or any other legal theory.

This warranty will apply to the full extent permitted by law. The invalidity, in whole or part, of any portion of this warranty will not affect the remainder.

## Ordering Procedure

Grooved End Butterfly Valves:  
Specify: (specify inch size) Model BFV-N Grooved End Butterfly Valve with internal supervisory switches, P/N (specify).

Valve Size	Valve Part Number
2-1/2 .....	59-300-F-025N
3 .....	59-300-F-030N
4 .....	59-300-F-040N
5 .....	59-300-F-050N
6 .....	59-300-F-060N
8 .....	59-300-F-080N
10 .....	59-300-F-010N

# Reliable®

## Model G 2½", 3", 4" & 6" (65mm, 80mm, 100mm, 150mm) Swing Check Valves

### The Right-Check™

#### Features

1. Grooved end connections.
2. Compact, lightweight design.
3. Non-slamming, spring loaded clapper to minimize water hammer.
4. Approved for horizontal and vertical installation.
5. Streamlined body design provides very low friction loss.
6. Elastomer faced clapper provides leak-free, non-sticking sealing.

#### General

Reliable Model G Swing Check Valves are multiple purpose valves performing regular check valve duties with very low friction loss. All four sizes are approved for use in fire protection systems. Typical applications include connections between public water supplies and private fire systems, at the discharge from fire pumps, at gravity tank connections and at fire department pumper connections.

The 4" (80mm) Model G Check Valve is provided with a ½" NPT (R½) supply side connection (Item 12, Fig.2). This supply side connection is optional for all other valve sizes and must be specified.

Grooved end connections provide fast and easy installation using listed or approved mechanical grooved couplings. Rigid style grooved couplings can be used for positive clamping to resist flexural and torsional loads.

Right-Check™ valves and associated equipment should periodically be given a thorough inspection and test. NFPA 25 provides minimum maintenance requirements. Check valves should be inspected and operated at least annually. Parts should be replaced as required.

When Model G Swing Check Valves are installed vertically, the direction of the flow arrow must point upward. For horizontal installations, the hinge pin must be located at the top.

#### Valve Description

1. Rated working pressure 250 psi (17,25 bar).
2. Factory hydrostatic test pressure 500 psi (34,5 bar).

Note: 1 bar=100 kPa

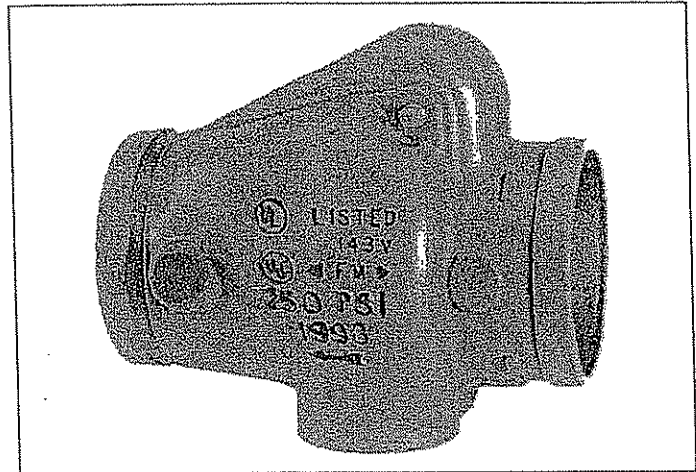
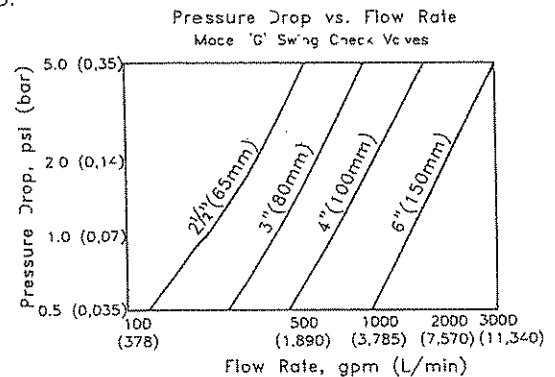


Figure 1

3. Friction loss, expressed in equivalent length of Sch. 40 pipe with C = 120 (based on Hazen and Williams formula):
  - 2½" - 7 ft. (65mm - 231cm)
  - 3" - 7 ft. (80mm - 213cm)
  - 4" - 10 ft. (100mm - 305cm)
  - 6" - 16 ft. (150mm - 488cm)
4. Standard grooved end dimensions per ANSI/AWWA C606.



#### Technical Data

Valve Size	Face-to-Face Dimensions	Shipping weight
2½" (65mm)	7.03" (178mm)	9 lbs. (4kg)
3" (80mm)	7.62" (193mm)	11 lbs. (5kg)
4" (100mm)	8.44" (214mm)	17 lbs. (7.7kg)
6" (150mm)	10.25" (260mm)	38 lbs. (17.25kg)

#### Approvals

1. Listed by Underwriters Laboratories, Inc.
2. Underwriters Laboratories certified for Canada.
3. Approved by Factory Mutual Research Corp.\*
4. NYC MEA 258-93-E.

\* FM Approved both a "Single" check valve and "Anti-Water Hammer" check valve.

## Parts List - Refer to Figure 2

Item No.	Part Name	Material	Quantity	Part Number			
				2½" (65mm)	3" (80mm)	4" (100mm)	6" (150mm)
1*	Valve Body	Gray Iron, ASTM-A48 Class 30A	1	91005022	91005023	91005024	91005026
2*	Seat	Bronze C83600 or C93200, ASTM-B505	1	96020200	96020300	96020400	96020600
3	Clapper	Stainless Steel 304, ASTM-A240	1	91816112	91816113	91816114	91816116
4	Facing Seal**	EPDM Rubber	1	95520200	95520300	95520400	95520600
5	Clamping Ring	Stainless Steel 304, ASTM-A240	1	95290300	95290300	95290400	95290600
6	Gasket**	EPDM Rubber	1	93720604	93720604	93720604	93720604
7	Spring	Stainless Steel 302, ASTM-A313	1	96400300	96400300	96400400	96400600
8	Hinge Pin	Stainless Steel 303, ASTM-A582	1	95000280	95000300	95006824	95000600
9	Bolt	Stainless Steel 304, ASTM-F593	1	91090600	91090600	91090600	91090600
10	Locknut**	Stainless Steel 303, ASTM-F594	1	94913816	94913816	94913816	94913816
11	Plug, ⅜" NPT	Steel	1	95201800	95201800	95201800	95201800
12	Plug, ½" NPT	Steel	1	Optional	Optional	98604402	Optional
** Replacement Seal Kit			1	6888040025	6888040030	6888040040	6888040060

\*Not field replaceable.

### Valve Disassembly

1. Close the main water supply valve and drain the system.
2. Remove the check valve from the piping system.
3. Inspect the Seat (2) for any cuts, scrapes and dents. Replace the valve if any damage is found.
4. To replace the Facing Seal (4), remove the Clapper (3), unscrew the Locknut (10) and remove the Retention Bolt (9).

### Valve Reassembly

1. Thoroughly clean the Clapper (3). Insert the Retention Bolt (9) with a new Gasket (6).
2. Place the new Facing Seal (4) and the Clamping Ring (5) against the Clapper (3). Tighten the new Locknut (10) to 21 in.-lbs. (2.37Nm) torque in 2½" (63mm) and 3" (76mm) sizes and to 52 in.-lbs. (5.87Nm) in 4" (101mm) and 6" (152mm) sizes.
3. Insert the clapper assembly into the valve through the downstream opening. Reinsert the Hinge Pin (8) while holding the coils of the properly oriented Spring (7) in place. Install the hinge pin Plug (11).
4. Reinstall the check valve in the system.
5. Place the system back in service.

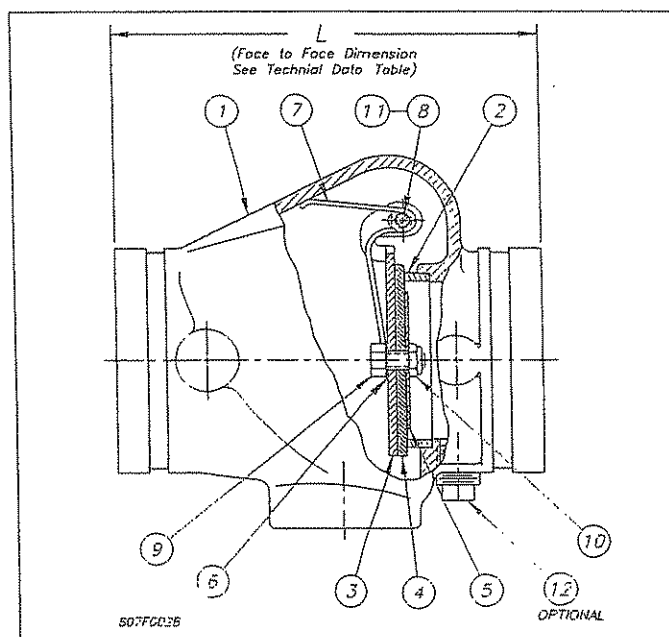


Figure 2

### Ordering Information

Specify:

1. Model G Right-Check™ Valve.
2. Size.
3. ½" NPT (R½) optional supply side connection for valve sizes other than 4" (100mm).

Contact the installing contractor or Reliable if any difficulties are experienced. Should replacement parts be needed, use only genuine Reliable parts.

The equipment presented in this bulletin is to be installed in accordance with the latest pertinent Standards of the National Fire Protection Association, Factory Mutual Research Corporation, or other similar organizations and also with the provisions of governmental codes or ordinances whenever applicable.

Products manufactured and distributed by Reliable have been protecting life and property for over 80 years, and are installed and serviced by the most highly qualified and reputable sprinkler contractors located throughout the United States, Canada and foreign countries.

Manufactured by



The Reliable Automatic Sprinkler Co., Inc.

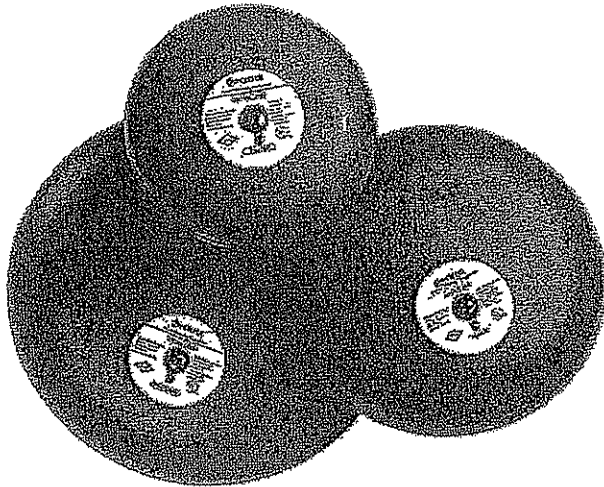
(800) 431-1588  
 (800) 848-6051  
 (914) 829-2042  
 www.reliablesprinkler.com

Sales Offices  
 Sales Fax  
 Corporate Offices  
 Internet Address



Revision lines indicate updated or new data.

EG. Printed in U.S.A. 11/07 P/N 9999970071



UL, ULC, and FM Approved

Sizes Available: 6" (150mm), 8" (200mm) and 10" (250mm)

Voltages Available: 24VAC  
120VAC  
12VDC (10.2 to 15.6) Polarized  
24VDC (20.4 to 31.2) Polarized

Service Use: Fire Alarm  
General Signaling  
Burglar Alarm

Environment: Indoor or outdoor use (See Note 1)  
-40° to 150°F (-40° to 66°C)  
(Outdoor use requires weatherproof  
backbox.)

Termination: AC Bells - 4 No. 18 AWG stranded wires  
DC Bells - Terminal strip

Finish: Red powder coating

Optional: Model BBK-1 weatherproof backbox  
Model BBX-1 deep weatherproof backbox



These vibrating type bells are designed for use as fire, burglar or general signaling devices. They have low power consumption and high decibel ratings. The unit mounts on a standard 4" (101mm) square electrical box for indoor use or on a model BBK-1 weatherproof backbox for outdoor applications. Weatherproof backbox model BBK-1, Stock No. 1500001.

ALL DC BELLS ARE POLARIZED AND HAVE BUILT-IN TRANSIENT PROTECTION:

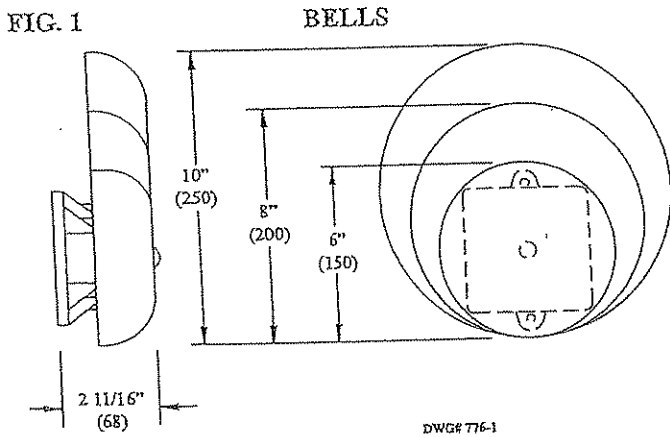
Size inches (mm)	Voltage	Model Number	Stock Number	Current (Max.)	Typical dB at 10 ft. (3m) (2)	Minimum dB at 10 ft. (3m) (1)
6 (150)	12VDC	MBA126	1750070	.12A	85	76
8 (200)	12VDC	MBA128	1750080	.12A	90	77
10 (250)	12VDC	MBA1210	1750060	.12A	92	78
6 (150)	24VDC	MBA246	1750100	.06A	87	77
8 (200)	24VDC	MBA248	1750110	.06A	91	79
10 (250)	24VDC	MBA2410	1750090	.06A	94	80
6 (150)	24VAC	PBA246	1806024	.17A	91	78
8 (200)	24VAC	PBA248	1808024	.17A	94	77
10 (250)	24VAC	PBA2410	1810024	.17A	94	78
6 (150)	120VAC	PBA1206	1806120	.05A	92	83
8 (200)	120VAC	PBA1208	1808120	.05A	99	84
10 (250)	120VAC	PBA12010	1810120	.05A	99	86

Notes:

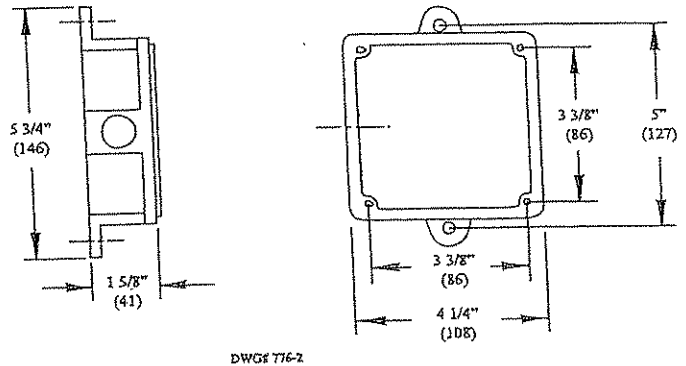
- Minimum dB ratings are calculated from integrated sound pressure measurements made at Underwriters Laboratories as specified in UL Standard 464. UL temperature range is -30° to 150°F (-34° to 66°C).
- Typical dB ratings are calculated from measurements made with a conventional sound level meter and are indicative of output levels in an actual installation.

Potter Electric Signal Company • 2081 Craig Road, St. Louis, MO, 63146-4161 • Phone: 800-325-3936/Canada 888-882-1833 • www.pottersignal.com

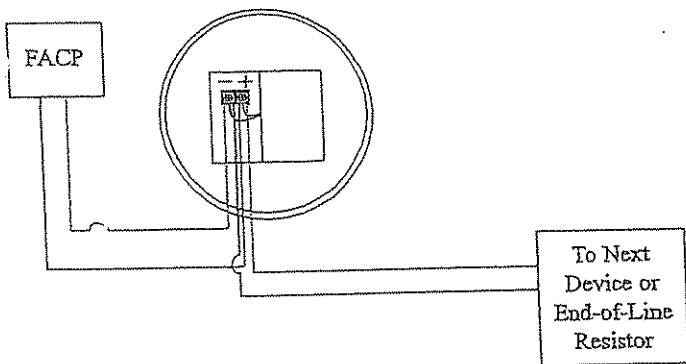
**DIMENSIONS**  
INCHES (mm).



**FIG. 2 WEATHERPROOF BACKBOX**  
BOX HAS ONE THREADED 1/2" CONDUIT ENTRANCE

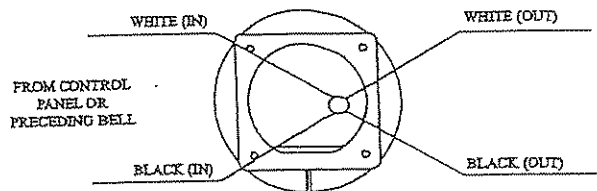


**FIG. 3**



**WIRING (REAR VIEW)**

**A.C. BELLS**



**CAUTION:**  
WHEN ELECTRICAL SUPERVISION IS REQUIRED USE IN AND OUT LEADS AS SHOWN.

**NOTES:**

1. WHEN USING AC BELLS, TERMINATE EACH EXTRA WIRE SEPARATELY AFTER LAST BELL.
2. END-OF-LINE RESISTOR IS NOT REQUIRED ON AC BELLS.

DWG# 776-3

**INSTALLATION**

1. The bell shall be installed in accordance with NFPA 13, 72, or local AHJ. The top of the device shall be no less than 90" AFF and not less than 6" below the ceiling.
2. Remove the gong.
3. Connect wiring (see Fig. 3).
4. Mount bell mechanism to backbox (bell mechanism must be mounted with the striker pointing down).
5. Reinstall the gong (be sure that the gong positioning pin, in the mechanism housing, is in the hole in the gong).
6. Test all bells for proper operation and observe that they can be heard where required (bells must be heard in all areas as designated by the authority having jurisdiction).



**GUARDIAN**

FIRE EQUIPMENT, INC.  
MIAMI, FL

Ph. 800.327.6584 • Fax 800.827.3869

**DETAIL AND SUBMITTAL SHEET**

**6100 Series - Projecting Fire Dept. Inlet Connections**

Project/Location: \_\_\_\_\_

Date: \_\_\_\_\_

Architect/Engineer: \_\_\_\_\_

Qty: \_\_\_\_\_

Contractor: \_\_\_\_\_

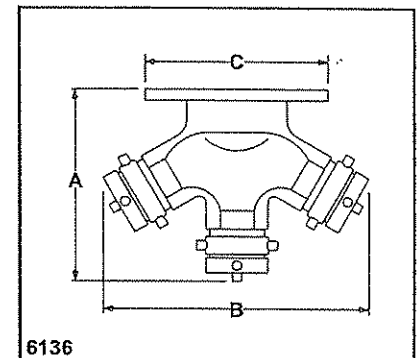
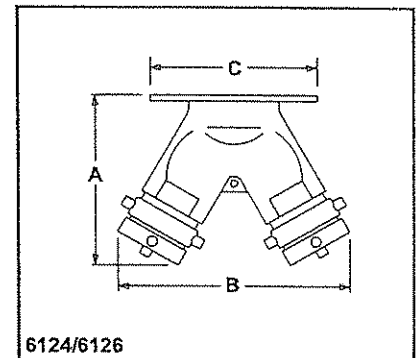
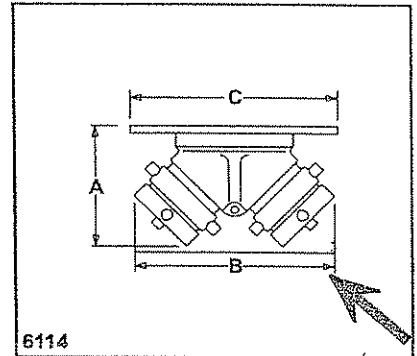
*Appropriate Selection*

Used as auxiliary connections through which the fire department can pump water to supplement existing water supplies. Provides 250 GPM flow (minimum), per 2 1/2" inlet.

**Two and three-way** - inlet connections feature clappered brass bodies (straight pattern), with female hose thread swivel inlets and female NPT outlets.

**Standard components, all connections:**

Plugs with chains and identification plate. Cast brass construction, standard.



Two and Three-Way Connections					
Model No.	Size	Clappers	A	B	C
<input checked="" type="checkbox"/> 6114	4" x 2 1/2" x 2 1/2"	1	5 1/8"	8 1/8"	10"
<input type="checkbox"/> 6124	4" x 2 1/2" x 2 1/2"	2	7 5/8"	10 1/2"	10"
<input type="checkbox"/> 6126	6" x 2 1/2" x 2 1/2"	2	8"	10 1/2"	11 1/4"
<input type="checkbox"/> 6136	6" x 2 1/2" x 2 1/2" x 2 1/2"	3	11 1/4"	13 3/4"	11 1/4"

**Identification Plate Lettering**

<input checked="" type="checkbox"/> AUTO SPKR	<input type="checkbox"/> AUTO SPKR & STANDPIPE
<input type="checkbox"/> STANDPIPE	<input type="checkbox"/> DRY STANDPIPE

Optional Finish:  -B Polished Brass  
 -C Rough Chrome Plated  
 -D Polished Chrome Plated

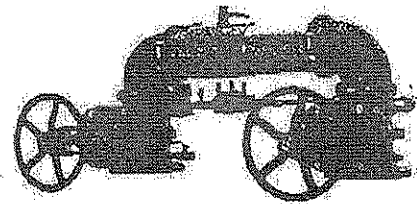
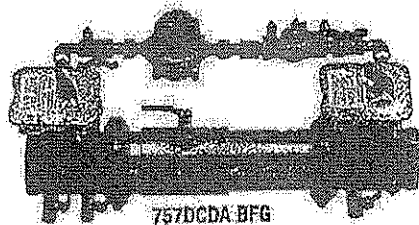
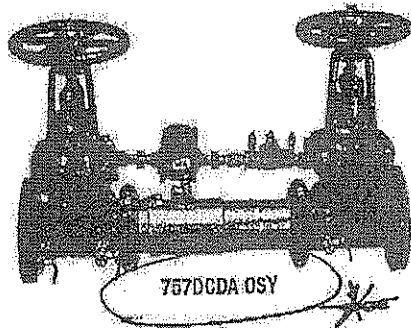
Threads:  NST  
 Other

# Series 757DCDA, 757NDCDA

## Double Check Detector Assemblies

Sizes: 2½" – 10" (65 – 250mm)

2 Double Check Detector Assemblies



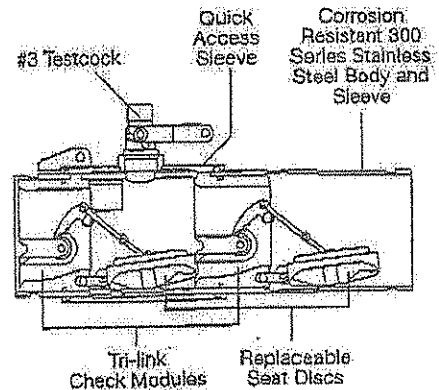
Series 757DCDA, 757NDCDA Double Check Detector Assemblies are used to prevent backflow of pollutants that are objectionable but not toxic, from entering the potable water supply system. This Series can be applied, where approved by the local authority having jurisdiction, on non-health hazard installations. The 757DCDA, 757NDCDA may be installed under continuous pressure service and may be subjected to backpressure. The 757DCDA, 757NDCDA are used primarily on fire line sprinkler systems when it is necessary to monitor unauthorized use of water.

### Features

- Extremely compact design
- 70% lighter than traditional designs
- Groove fittings allow integral pipeline adjustment
- Patented tri-link checks provide lowest pressure loss
- Unmatched ease of serviceability
- Available with grooved butterfly valve shutoffs
- May be used for horizontal, vertical or N pattern installations
- Replaceable check disc rubber

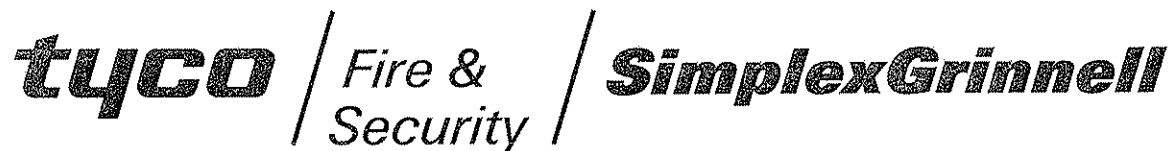
### Materials

- Housing & Sleeve: 304 (Schedule 40) Stainless Steel
- Elastomers: EPDM, Silicone and Buna-N
- Tri-link Checks: Noryl® Stainless Steel
- Check Discs: Reversible Silicone or EPDM
- Test Cocks: Bronze Body Nickel Plated
- Pins & Fasteners: 300 Series Stainless Steel
- Springs: Stainless Steel



### Pressure-Temperature

Temperature Range: 33°F – 110°F  
(5°C – 43°C)  
Maximum Working Pressure: 175psi  
(12.06 bar)



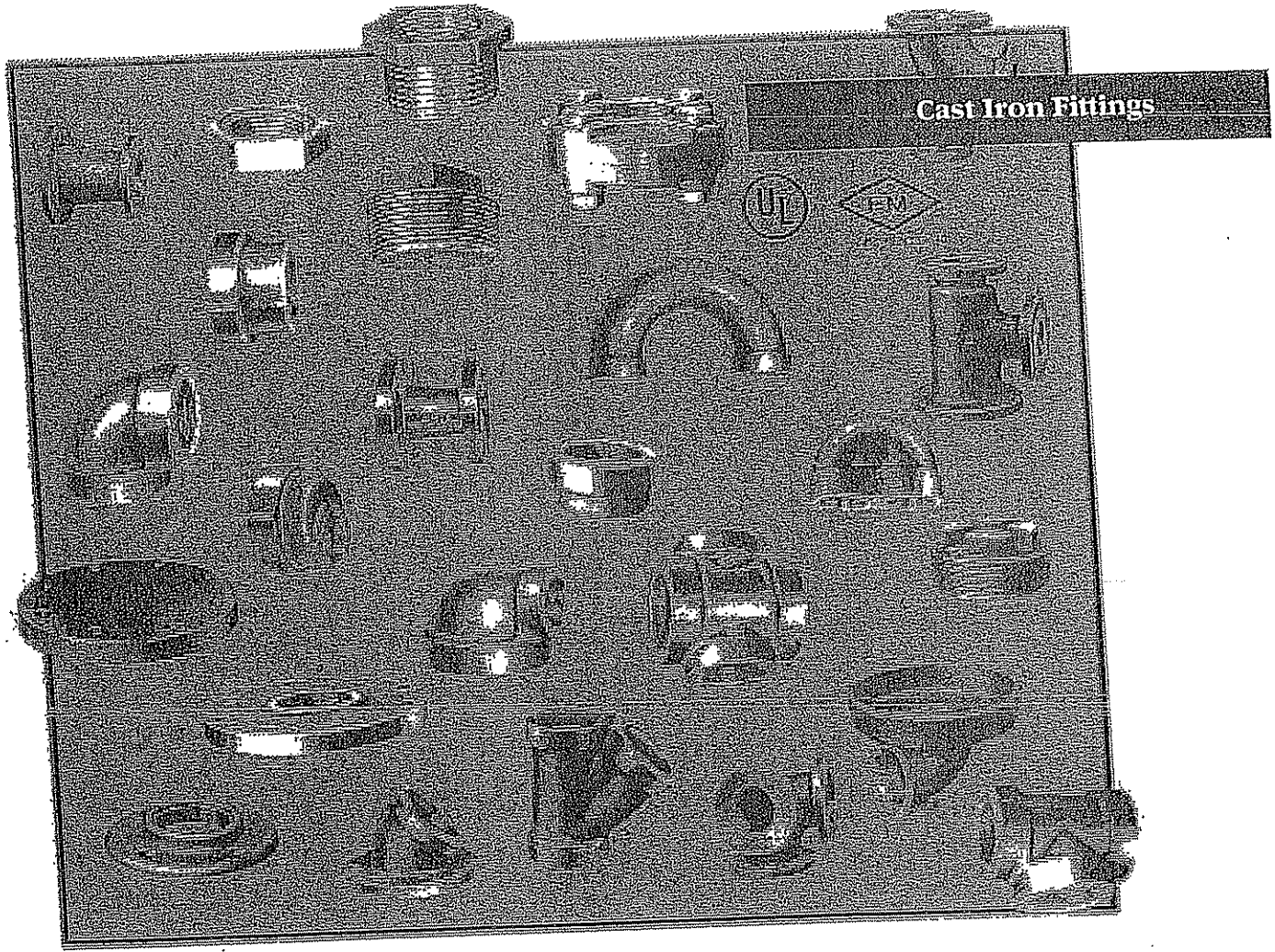
**STENNIS RIVERINE & COMBATANT TRAINING**  
**FACILITY**  
**STENNIS SPACE CENTER**  
**STENNIS, MS 39529**

**FIRE PROTECTION/ SPRINKLER SYSTEMS**  
**OPERATIONS BUILDING 2440/2441**  
**BOAT STORAGE BUILDING 2442**

# **SECTION 3**

# **FITTINGS**

**SIMPLEXGRINNELL**  
**5800 JEFFERSON HWY., SUITE A**  
**HARAHAN, LA 70123**  
**PHONE: 504-736-0104**  
**FAX: 504-736-9292**




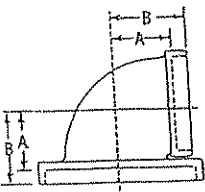
Anvil standard and extra heavy cast iron threaded fittings are manufactured in accordance with ASME-B16.4 (except plugs and bushings, ASME B16.14). Dimensions also conform to Federal Specifications, WW-P-501 (except plugs and bushings WW-P-471).

Anvil standard and extra heavy fittings in this section, sizes 1/4 NPS - 12NPS (8 - 300 DN), are included in the "List of Inspected Fire Protection Equipment and Materials" issued by the Underwriters' Laboratories, Inc.

Cast Iron Threaded Fittings Pressure - Temperature Ratings					
Temperature		Pressure			
		Class 125		Class 250	
(°F)	(°C)	psi	bar	psi	bar
-20° to 150°	-28.9 to 65.6	175	12.1	400	27.6
200°	93.3	165	11.4	370	25.5
250°	121.1	150	10.3	340	23.4
300°	148.9	140	9.7	310	21.4
350°	176.7	125	8.6	300	20.7
400°	204.4	-	-	250	17.2



## Cast Iron Threaded Fittings Class 125, (Standard)

90° Elbow Straight Figure 351	Size		A		B		Weight			
							black		galv.	
	NPS	DN	in	mm	in	mm	lbs	kg	lbs	kg
 	1/4	8	1/2	13	13/16	22	0.16	0.07	0.17	0.08
	3/8	10	5/16	14	15/16	24	0.25	0.11	0.26	0.12
	1/2	15	11/16	17	1	29	0.40	0.18	0.41	0.19
	3/4	20	13/16	22	1 1/16	33	0.60	0.27	0.61	0.28
	1	25	15/16	24	1 1/2	38	0.82	0.42	0.95	0.43
	1 1/4	32	1 1/8	29	1 3/4	44	1.4	0.65	1.5	0.66
	1 1/2	40	1 3/8	33	1 15/16	49	2.0	0.88	2.0	0.91
	2	50	1 7/8	40	2 1/4	57	3.1	1.4	3.2	1.5
	2 1/2	65	1 13/16	47	2 11/16	68	4.9	2.2	5.1	2.3
	3	80	2 1/8	56	3 1/4	79	7.2	3.3	7.4	3.4
	4	100	2 11/16	68	3 9/16	98	12	5.5	13	5.7
	5	125	3 5/16	84	4 1/2	114	21	10	—	—
6	150	3 3/4	98	5 1/2	130	31	14	33	15	
8	200	5 7/16	132	6 5/16	167	65	29	67	30	

90° Elbow Flanged and Threaded Figure 371							
Size		A		B		Weight black	
NPS	DN	in	mm	in	mm	lbs	kg
2 1/2	65	1 13/16	47	2 11/16	68	10	4.6
3	80	2 1/8	56	3 1/4	79	13	6.0
4	100	2 11/16	68	3 9/16	98	22	10
5	125	3 5/16	84	4 1/2	114	28	13
6	150	3 3/4	98	5 1/2	130	41	18
8	200	5 7/16	132	6 5/16	167	80	36


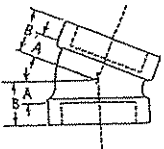
\*Nominal Pipe Sizes of 4" (100 DN) and larger have two holes tapped for stud or tap bolts.

45° Elbow Flanged and Threaded Figure 372							
Size		A		B		Weight black	
NPS	DN	in	mm	in	mm	lbs	kg
4	100	1 1/8	40	2 5/8	67	20	9.0
6	150	2 1/8	56	3 1/8	87	35	16
8	200	2 3/4	73	4 1/4	108	64	29

Note: See page PF-75 for pressure-temperature ratings.


# Cast Iron Threaded Fittings Class 125, (Standard)




22 1/2° Elbow Figure 356A	Size		A		B		Weight black	
	NPS	DN	in	mm	in	mm	lbs	kg
		3/4	20	3/8	10	7/8	22	0.52
	1	25	7/16	11	1	25	0.80	0.36
	1 1/4	32	1/2	13	1 1/4	29	1.4	0.64
	1 1/2	40	5/8	16	1 1/4	32	1.6	0.74
	2	50	3/4	19	1 7/8	37	2.5	1.1
	2 1/2	65	3/4	19	1 1/2	41	4.0	1.8

Galvanized Not Steel

Note: See page PF-75 for pressure-temperature ratings.

45° Elbow Figure 356	Size		A		B		Weight			
	NPS	DN	in	mm	in	mm	black		galv.	
							lbs	kg	lbs	kg
	3/4	8	7/16	11	3/4	19	0.16	0.07	0.17	0.08
	1	10	7/16	11	13/16	22	0.23	0.10	—	—
	1/2	15	7/16	11	1/2	22	0.37	0.17	0.38	0.17
	3/4	20	1/2	13	1	25	0.55	0.25	0.56	0.25
	1*	25	9/16	14	1 1/4	29	0.83	0.38	0.88	0.40
	1 1/4	32	5/8	16	1 1/4	32	1.3	0.60	1.4	0.62
	1 1/2	40	13/16	22	1 7/8	37	1.8	0.81	1.8	0.83
	2	50	1	25	1 13/16	43	2.9	1.3	3.0	1.3
	2 1/2	65	1 1/8	27	1 15/16	49	4.3	1.9	4.3	2.0
	3	80	1 1/4	30	2 1/8	56	6.4	2.9	6.7	3.0
	3 1/2	90	1 3/4	35	2 3/4	60	8.4	3.8	—	—
	4	100	1 7/8	40	2 5/4	67	11	4.8	11	5.1
	5	125	1 3/4	48	3 1/8	78	17	7.7	17	7.9
	6	150	2 1/8	56	3 7/8	87	26	12	26	12
8	200	2 3/4	73	4 1/4	108	50	23	52	24	

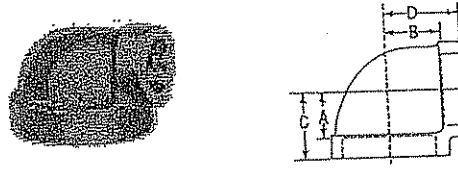
\* 1 NPS (25 DN) size available in 1 NPS x 1/2 NPS (25 x 15 DN) reducing size, black or galvanized.

Straight Tee Figure 35B	Size		A		B		Weight			
	NPS	DN	in	mm	in	mm	black		galv.	
							lbs	kg	lbs	kg
	1/4	8	1/2	13	3/4	22	0.22	0.10	0.23	0.10
	3/8	10	5/8	16	1	25	0.35	0.16	0.36	0.16
	1/2	15	1 1/16	17	1 1/4	29	0.56	0.25	0.58	0.26
	3/4	20	1 3/16	22	1 5/8	33	0.84	0.38	0.85	0.39
	1	25	1 5/8	24	1 1/2	38	1.3	0.57	1.3	0.59
	1 1/4	32	1 7/8	29	1 3/4	44	2.0	0.9	2.1	0.9
	1 1/2	40	1 7/8	33	1 15/16	49	2.7	1.2	2.7	1.2
	2	50	1 7/8	40	2 1/4	57	4.2	1.9	4.3	2.0
	2 1/2	65	1 13/16	47	2 11/16	68	6.7	3.0	6.8	3.1
	3	80	2 1/8	56	3 1/4	79	10.0	4.5	10	4.6
	3 1/2	90	2 7/8	62	3 1/8	87	13	6.0	14	6.3
	4	100	2 11/16	68	3 3/4	95	16	7.4	17	7.7
	5	125	3 5/8	84	4 1/2	114	27	12	28	13
6	150	3 7/8	98	5 1/2	130	41	19	41	19	
8	200	5 3/8	132	6 7/8	167	79	36	81	37	



## Cast Iron Threaded Fittings Class 125, (Standard)

90° Reducing  
Elbow - Figure 352



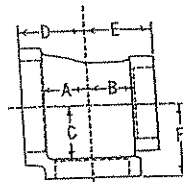
Size				A		B		C		D		Weight black	
NPS	DN	NPS	DN	in	mm	in	mm	in	mm	in	mm	lbs	kg
1/2	15	1/4	8	5/8	16	3/4	19	1 1/16	27	1 1/16	27	0.40	0.18
		3/8	10	5/8	16	13/16	17	1 1/16	27	1 1/16	27	0.34	0.15
3/4	20	1/2	15	1 1/16	17	13/16	22	1 1/4	32	1 1/4	32	0.51	0.23
		3/4	20	1 3/16	22	1 3/16	24	1 3/8	35	1 3/8	35	0.67	0.30
1	25	1/2	15	1 1/16	17	1 3/16	24	1 1/4	37	1 1/4	37	0.76	0.34
		3/4	20	1 3/16	22	1 3/16	24	1 1/2	38	1 1/2	38	1.1	0.49
1 1/4	32	1/2	15	1 1/16	17	1 1/2	27	1 5/8	41	1 5/8	41	1.0	0.46
		3/4	20	1 3/16	22	1 1/2	29	1 5/8	41	1 5/8	41	1.2	0.55
		1	25	1 5/16	24	1 1/2	29	1 11/16	43	1 11/16	43	1.5	0.69
1 1/2	40	1/2	15	3/4	19	1 1/4	32	1 5/8	41	1 5/8	41	1.6	0.70
		3/4	20	7/8	22	1 3/4	33	1 13/16	47	1 13/16	47	1.4	0.65
		1	25	1	25	1 1/4	32	1 13/16	47	1 13/16	47	1.7	0.79
		1 1/4	32	1 3/8	30	1 1/4	32	1 1/4	48	1 3/4	48	2.2	1.0
2	50	1/2	15	1 3/16	30	1 3/4	37	1 3/4	35	1 3/4	35	2.2	1.0
		3/4	20	1 3/16	33	1 1/2	38	2	51	2	51	2.2	1.0
		1	25	1 1/16	27	1 3/4	37	2	51	2	51	2.1	0.9
		1 1/4	32	1 3/16	30	1 3/4	37	2 1/16	52	2 1/16	52	2.3	1.1
		1 1/2	40	1 5/16	33	1 1/2	38	2 1/8	54	2 1/8	54	2.6	1.2
2 1/2	65	1	25	1	25	1 3/4	44	2 5/16	59	2 5/16	59	2.9	1.3
		1 1/4	32	1 3/16	30	1 3/4	44	2 3/8	60	2 3/8	60	3.4	1.5
		1 1/2	40	1 5/16	33	1 3/4	47	2 1/16	62	2 1/16	62	3.7	1.7
		2	50	1 7/16	40	1 1/2	48	2 3/16	65	2 3/16	65	4.0	1.8
3	80	1 1/4	32	1 3/8	41	2 3/16	59	2 5/16	75	2 5/16	75	6.0	2.7
		1 1/2	40	1 3/8	41	2 5/16	59	2 5/16	75	2 5/16	75	5.7	2.6
		2	50	1 3/4	41	2 1/4	57	2 5/16	75	2 5/16	75	5.7	2.6
		2 1/2	65	1 1/4	48	2 3/8	56	3 1/16	78	3 1/16	78	6.4	2.9
3 1/2	90	3	80	2 3/16	56	2 1/16	62	3 3/8	86	3 3/8	86	8.9	4.1
4	100	2	50	2 3/16	56	2 15/16	75	3 5/8	92	3 5/8	92	12	5.4
		2 1/2	65	2 3/16	56	2 3/4	70	3 5/8	92	3 5/8	92	11	5.1
		3	80	2 5/16	56	2 11/16	68	3 5/8	92	3 5/8	92	11	4.8
		3 1/2	90	2 7/16	62	2 11/16	68	3 11/16	94	3 11/16	94	12	5.4
5	125	2 1/2	65	2 5/16	73	3 1/2	89	4 1/4	111	4 1/4	111	20	9.0
		3	80	2 13/16	73	3 5/16	87	4 1/4	111	4 1/4	111	19	8.6
		4	100	2 13/16	73	3 5/16	84	4 3/4	111	4 3/8	111	16	7.5
6	150	3	80	2 3/16	59	3 13/16	98	4 13/16	124	4 13/16	124	19	8.8
		4	100	2 3/16	73	3 3/4	98	4 13/16	125	4 13/16	125	24	11
		5	125	3 3/8	86	3 13/16	98	5	127	5	127	27	12
8	200	6	150	4 3/16	106	5 1/4	130	6 3/8	162	6 3/8	162	51	23

Note: See page PF-75 for pressure-temperature ratings.

# Cast Iron Threaded Fittings Class 125, (Standard)



Reducing Tee  
Figure 359



Reducing Tee: Figure 359																	Wt.						
Size				A		B		C		D		E		F		black		galv.					
NPS	DN	NPS	DN	NPS	DN	in	mm	in	mm	in	mm	in	mm	in	mm	in	mm	ins	kg	lbs	kg		
1/2	15	1/2	15	1/4	8	11/16	17	11/16	17	13/16	22	1 1/4	29	1 1/4	29	1 1/4	29	0.57	0.26	-	-		
				3/8	10	11/16	17	11/16	17	3/4	19	1 1/4	29	1 1/4	29	1 1/4	29	0.57	0.26	-	-		
				3/4	20	13/16	22	13/16	22	11/16	17	1 1/4	32	1 1/4	32	1 3/16	22	0.68	0.31	-	-		
				1	25	1	25	1	25	13/16	22	1 1/4	37	1 1/4	37	1 3/4	35	1.00	0.45	-	-		
3/4	20	1/2	15	1/4	8	13/16	22	13/16	22	13/16	22	1 1/4	29	1 1/4	29	1 1/4	29	0.64	0.29	-	-		
				1/2	15	11/16	17	11/16	17	13/16	22	1 1/4	29	1 1/4	29	1 1/4	29	0.75	0.34	-	-		
		3/4	20	13/16	22	13/16	22	13/16	22	1 1/4	32	1 1/4	32	1 3/16	22	0.62	0.28	-	-				
		1	25	1	25	1	25	13/16	22	1 1/4	37	1 1/4	37	1 3/4	35	0.75	0.34	-	-				
	1	25	3/4	20	1/4	8	3/4	14	3/4	14	3/4	22	1 1/4	17	1 1/4	17	1 3/4	22	0.62	0.28	-	-	
					3/8	10	11/16	17	11/16	17	13/16	24	1 1/4	22	1 1/4	22	1 1/4	22	0.75	0.34	-	-	
			1/2	15	11/16	17	11/16	17	13/16	22	1 1/4	22	1 1/4	22	1 1/4	22	0.76	0.34	-	-			
			1	25	13/16	24	13/16	24	13/16	22	1 1/4	37	1 1/4	37	1 3/4	35	0.99	0.45	-	-			
1	25	1/2	15	1/4	8	1	25	13/16	24	13/16	24	1 1/2	38	1 1/4	32	1 3/16	22	1 3/4	35	0.90	0.41	-	-
				1/2	15	11/16	17	3/4	19	13/16	24	1 1/4	32	1 3/16	22	1 3/4	35	0.91	0.41	-	-		
		3/4	20	13/16	22	13/16	22	13/16	24	1 1/4	35	1 1/4	32	1 1/16	37	1.1	0.49	-	-				
		1	25	13/16	24	13/16	24	13/16	24	1 1/4	38	1 1/4	35	1 1/2	38	1.1	0.49	-	-				
		1/2	15	11/16	17	13/16	17	13/16	24	1 1/4	32	13/16	22	1 3/4	35	0.89	0.40	-	-				
		3/4	20	13/16	22	13/16	22	13/16	24	1 1/4	35	13/16	24	1 1/16	37	1.00	0.45	-	-				
	1	25	1	25	1/4	8	11/16	17	13/16	17	1 1/4	29	1 1/4	29	1 1/4	32	1 3/4	35	1.0	0.46	1.0	0.47	
					1/2	15	11/16	17	13/16	17	13/16	24	1 1/4	32	1 1/4	32	1 3/4	35	1.1	0.50	-	-	
			3/4	20	13/16	22	13/16	22	13/16	24	1 1/4	35	1 1/4	35	1 3/16	37	1.1	0.50	-	-			
			1 1/4	32	1 1/2	29	1 1/2	29	13/16	24	1 1/4	43	1 1/16	43	1 3/16	40	1.5	0.68	-	-			
			1 1/2	40	1 1/4	32	1 1/4	32	1	25	1 1/4	47	1 1/16	47	1 3/4	41	1.8	0.83	-	-			
			2	50	1 1/4	32	1 1/4	32	1 1/4	32	1 1/4	52	1 1/16	52	1 3/4	41	1.00	0.45	-	-			
1 1/4	32	1/2	15	1/4	8	13/16	22	13/16	22	1 1/4	29	1 1/4	29	1 1/4	37	1 3/16	24	1 3/4	43	1.4	0.63	-	-
				1	25	13/16	24	13/16	24	1 1/4	29	1 3/16	40	1 3/16	40	1 3/4	44	1.6	0.74	-	-		
				1 1/4	32	1 1/4	29	1 1/4	29	1 1/4	29	1 3/16	44	1 3/16	40	1 3/4	41	1.3	0.58	-	-		
		3/4	20	1/4	8	13/16	22	13/16	22	1 1/4	29	1 1/4	29	1 1/4	37	1 3/16	24	1 3/4	41	1.4	0.65	-	-
				1	25	13/16	24	13/16	24	1 1/4	29	1 3/16	40	1 3/16	37	1 1/16	43	1.4	0.65	-	-		
				1 1/4	32	1 1/4	29	1 1/4	29	1 1/4	29	1 3/16	44	1 3/16	41	1 3/4	44	1.7	0.78	-	-		
	1	25	1/4	8	13/16	22	13/16	22	1 1/4	29	1 1/4	29	1 1/4	37	1 3/16	24	1 3/4	40	1.3	0.58	1.3	0.59	
			1/2	15	11/16	17	13/16	17	1 1/4	29	1 1/4	29	1 1/4	37	1 3/16	35	1 3/4	41	1.4	0.62	-	-	
			3/4	20	13/16	22	13/16	22	1 1/4	29	1 3/16	40	1 3/16	40	1 3/4	41	1.4	0.62	-	-			
			1	25	13/16	24	13/16	24	1 1/4	29	1 3/16	40	1 3/16	40	1 1/16	43	1.5	0.69	1.6	0.71			
			1 1/4	32	1 1/4	29	1 1/4	29	1 1/4	29	1 3/16	44	1 1/16	43	1 3/4	44	1.8	0.81	-	-			
			1 1/2	40	1 1/4	32	1 1/4	32	13/16	22	1 1/4	48	1 1/16	47	1 13/16	47	2.1	0.9	-	-			
1 1/4	32	1/2	15	1/4	8	13/16	22	13/16	22	1 1/4	29	1 1/4	29	1 1/4	37	1 3/16	24	1 3/4	41	1.5	0.71	-	-
				1	25	13/16	24	13/16	24	1 1/4	29	1 3/16	40	1 3/16	40	1 3/4	43	1.7	0.78	-	-		
				1 1/4	32	1 1/4	29	1 1/4	29	1 1/4	29	1 3/16	44	1 3/16	40	1 1/16	47	2.3	1.0	-	-		
		1	25	1/2	15	11/16	17	13/16	17	1 1/4	29	1 1/4	29	1 1/4	37	1 3/16	37	1 3/4	41	1.5	0.67	-	-
				3/4	20	13/16	22	13/16	22	1 1/4	29	1 3/16	40	1 3/16	40	1 1/16	43	1.7	0.78	-	-		
				1	25	13/16	24	13/16	24	1 1/4	29	1 3/16	40	1 3/16	40	1 1/16	43	1.7	0.78	-	-		
1 1/4	32	1/2	15	11/16	17	13/16	17	1 1/4	29	1 1/4	29	1 1/4	37	1 3/16	37	1 3/4	41	1.5	0.67	-	-		
		3/4	20	13/16	22	13/16	22	1 1/4	29	1 3/16	40	1 3/16	40	1 1/16	43	1.7	0.78	-	-				
		1	25	13/16	24	13/16	24	1 1/4	29	1 3/16	40	1 3/16	40	1 1/16	43	1.7	0.78	-	-				
1 1/4	32	1/2	15	11/16	17	13/16	17	1 1/4	29	1 1/4	29	1 1/4	37	1 3/16	37	1 3/4	41	1.5	0.67	-	-		
		3/4	20	13/16	22	13/16	22	1 1/4	29	1 3/16	40	1 3/16	40	1 1/16	43	1.7	0.78	-	-				
		1	25	13/16	24	13/16	24	1 1/4	29	1 3/16	40	1 3/16	40	1 1/16	43	1.7	0.78	-	-				
1 1/4	32	1/2	15	11/16	17	13/16	17	1 1/4	29	1 1/4	29	1 1/4	37	1 3/16	37	1 3/4	41	1.5	0.67	-	-		
		3/4	20	13/16	22	13/16	22	1 1/4	29	1 3/16	40	1 3/16	40	1 1/16	43	1.7	0.78	-	-				
		1	25	13/16	24	13/16	24	1 1/4	29	1 3/16	40	1 3/16	40	1 1/16	43	1.7	0.78	-	-				
1 1/4	32	1/2	15	11/16	17	13/16	17	1 1/4	29	1 1/4	29	1 1/4	37	1 3/16	37	1 3/4	41	1.5	0.67	-	-		
		3/4	20	13/16	22	13/16	22	1 1/4	29	1 3/16	40	1 3/16	40	1 1/16	43	1.7	0.78	-	-				
		1	25	13/16	24	13/16	24	1 1/4	29	1 3/16	40	1 3/16	40	1 1/16	43	1.7	0.78	-	-				
1 1/4	32	1/2	15	11/16	17	13/16	17	1 1/4	29	1 1/4	29	1 1/4	37	1 3/16	37	1 3/4	41	1.5	0.67	-	-		
		3/4	20	13/16	22	13/16	22	1 1/4	29	1 3/16	40	1 3/16	40	1 1/16	43	1.7	0.78	-	-				
		1	25	13/16	24	13/16	24	1 1/4	29	1 3/16	40	1 3/16	40	1 1/16	43	1.7	0.78	-	-				
1 1/4	32	1/2	15	11/16	17	13/16	17	1 1/4	29	1 1/4	29	1 1/4	37	1 3/16	37	1 3/4	41	1.5	0.67	-	-		
		3/4	20	13/16	22	13/16	22	1 1/4	29	1 3/16	40	1 3/16	40	1 1/16	43	1.7	0.78	-	-				
		1	25	13/16	24	13/16	24	1 1/4	29	1 3/16	40	1 3/16	40	1 1/16	43	1.7	0.78	-	-				
1 1/4	32	1/2	15	11/16	17	13/16	17	1 1/4	29	1 1/4	29	1 1/4	37	1 3/16	37	1 3/4	41	1.5	0.67	-	-		
		3/4	20	13/16	22	13/16	22	1 1/4	29	1 3/16	40	1 3/16	40	1 1/16	43	1.7	0.78	-	-				
		1	25	13/16	24	13/16	24	1 1/4	29	1 3/16	40	1 3/16	40	1 1/16	43	1.7	0.78	-	-				
1 1/4	32	1/2	15	11/16	17	13/16	17	1 1/4	29	1 1/4	29	1 1/4	37	1 3/16	37	1 3/4	41	1.5	0.67	-	-		
		3/4	20	13/16	22																		



# Cast Iron Threaded Fittings Class 125, (Standard)

Reducing Tee: Figure 359

Size				A		B		C		D		E		F		Wt.						
																black		galv.				
NPS	Dn	NPS	DN	NPS	DN	in	mm	in	mm	in	mm	in	mm	in	mm	in	mm	lbs	kg	lbs	kg	
1 1/2	40	1/2	15	1 1/4	32	1 1/8	22	1 1/4	29	1 1/4	32	1 13/16	47	1 1/8	40	1 1/2	48	1.9	0.88	-	-	
				1 1/2	40	1 5/16	24	1 1/4	32	1 5/16	24	1 15/16	49	1 11/16	43	1 15/16	49	2.1	1.0	-	-	
		3/4	20	1 1/2	40	1 5/16	24	1 1/4	32	1 5/16	24	1 15/16	49	1 3/4	44	1 15/16	49	2.2	1.0	-	-	
				1 1/2	40	1 5/16	24	1 1/4	32	1 5/16	24	1 15/16	49	1 3/4	44	1 15/16	49	1.8	0.79	-	-	
		1	25	1/2	15	1 1/8	22	3/4	19	1 1/4	32	1 1/8	37	1 5/16	24	1 11/16	43	1.7	0.77	-	-	
				3/4	20	7/8	22	13/16	22	1 1/4	32	1 1/2	38	1 3/8	35	1 3/4	44	1.7	0.78	-	-	
				1	25	1	25	1 5/16	24	1 1/4	32	1 1/2	41	1 1/2	38	1 3/4	44	2.1	0.9	-	-	
				1 1/4	32	1 3/8	22	1 1/4	29	1 1/4	32	1 13/16	47	1 11/16	43	1 1/2	48	2.3	1.0	-	-	
				1 1/2	40	1 5/16	24	1 1/4	32	1 5/16	24	1 15/16	49	1 13/16	47	1 15/16	49	2.9	1.3	-	-	
				2	50	1 1/2	38	1 1/8	37	1 5/16	24	2 1/8	54	2	51	2	51	2.9	1.3	-	-	
		1/4	32	1/2	15	1 1/8	22	1 1/8	17	1 1/4	32	1 1/2	38	1 1/8	37	1 3/4	44	1.8	0.81	-	-	
				3/4	20	3/4	22	1 1/8	22	1 1/4	32	1 1/2	38	1 1/8	37	1 3/4	44	2.0	0.89	2.0	0.9	
	1			25	1	25	1 5/16	24	1 1/4	32	1 3/8	41	1 3/8	40	1 13/16	47	2.3	1.0	-	-		
	1 1/4			32	1 3/8	22	1 1/4	29	1 1/4	32	1 13/16	47	1 3/8	44	1 1/2	48	2.5	1.1	-	-		
	1 1/2			40	1 5/16	24	1 1/4	32	1 5/16	24	1 15/16	49	1 1/2	48	1 15/16	49	3.1	1.4	-	-		
	2			50	1 1/2	38	1 1/8	37	1 5/16	24	2 1/8	54	2 1/8	52	2	51	3.1	1.4	-	-		
	1/2	40	1/2	15	1 1/8	22	1 1/8	22	1 1/4	32	1 1/8	37	1 1/8	37	1 3/8	44	1.8	0.83	-	-		
			3/4	20	3/4	22	3/8	22	1 1/4	32	1 1/2	38	1 1/2	38	1 3/4	47	2.1	1.0	2.2	1.0		
			1	25	1	25	1	25	1 1/4	32	1 5/8	41	1 5/8	41	1 3/4	47	2.4	1.1	-	-		
			1 1/4	32	1 5/16	22	1 3/8	22	1 1/4	32	1 13/16	47	1 13/16	47	1 1/2	48	2.4	1.1	-	-		
			1 1/2	40	1 5/16	24	1 1/4	32	1 5/16	24	1 15/16	49	1 1/2	48	1 15/16	49	3.2	1.5	-	-		
			2	50	1 1/2	38	1 1/8	38	1 5/16	24	2 1/8	54	2 1/8	52	2	51	3.2	1.5	-	-		
	2	2	1/2	15	1 1/4	40	1 5/16	24	1 3/8	35	1 1/2	38	2	51	1 13/16	47	2 1/8	54	3.0	1.3	-	-
					1 1/2	40	1 5/16	24	1 3/8	35	1 1/2	38	2	51	1 13/16	47	2 1/8	54	3.3	1.5	-	-
3/4			20	1 1/4	40	1 5/16	24	1 3/8	35	1 1/2	38	2	51	1 13/16	47	2 1/8	54	3.4	1.5	-	-	
				1 1/2	40	1 5/16	24	1 3/8	35	1 1/2	38	2	51	1 13/16	47	2 1/8	54	3.3	1.5	-	-	
1			25	1	25	1 1/16	17	1 1/8	17	1 1/8	37	1 3/4	44	1 3/4	41	2	51	2.7	1.2	-	-	
				1 1/4	32	1 3/8	22	1 1/4	29	1 1/2	38	1 1/4	48	1 3/4	44	2 1/8	52	2.9	1.3	-	-	
				1 1/2	40	1 5/16	24	1 1/4	32	1 1/2	38	2	51	1 13/16	47	2 1/8	54	2.9	1.3	-	-	
				2	50	1 3/8	40	1 1/8	37	1 3/8	40	2 1/4	57	2	51	2 1/4	57	3.5	1.6	-	-	
				2 1/2	65	1 3/8	48	1 13/16	47	1 3/8	40	2 3/8	65	2 3/8	60	2 1/8	62	4.9	2.2	-	-	
				2 1/2	65	1 3/8	48	1 13/16	47	1 3/8	40	2 3/8	65	2 3/8	60	2 1/8	62	4.9	2.2	-	-	
1/4			32	1/2	15	1 1/8	17	1	25	1 1/8	37	1 3/4	44	1 3/4	41	2	51	2.5	1.1	-	-	
				3/4	20	3/4	22	3/4	22	1 1/8	37	1 3/4	44	1 3/4	41	2	51	2.7	1.2	-	-	
		1		25	1 1/16	17	1	25	1 1/8	37	1 3/4	44	1 3/4	41	2	51	2.7	1.2	-	-		
		1 1/4		32	1 3/8	22	1 1/4	29	1 1/2	38	1 1/4	48	1 3/4	44	2 1/8	52	2.9	1.3	-	-		
		1 1/2		40	1 5/16	24	1 1/4	32	1 1/2	38	2	51	1 3/4	48	2 1/8	54	3.1	1.4	-	-		
		2		50	1 3/8	40	1 1/8	37	1 3/8	40	2 1/4	57	2 1/4	52	2 1/4	57	3.7	1.7	-	-		
1/2		40	1/2	15	1 1/8	17	1	25	1 1/8	37	1 3/4	44	1 3/4	41	2	51	2.5	1.1	-	-		
			3/4	20	3/4	22	3/4	22	1 1/8	37	1 3/4	44	1 3/4	41	2	51	2.7	1.2	-	-		
			1	25	1 1/16	17	1	25	1 1/8	37	1 3/4	44	1 3/4	41	2	51	2.7	1.2	-	-		
			1 1/4	32	1 3/8	22	1 1/8	22	1 1/8	37	1 3/4	44	1 3/4	41	2	51	2.5	1.1	-	-		
			1 1/2	40	1 5/16	24	1 1/4	32	1 1/2	38	2	51	1 3/4	48	2 1/8	54	3.1	1.4	-	-		
			2	50	1 3/8	40	1 1/8	37	1 3/8	40	2 1/4	57	2 1/4	52	2 1/4	57	3.7	1.7	-	-		
2		50	1/2	15	1 1/8	17	1	25	1 1/8	37	1 3/4	44	1 3/4	41	2	51	2.5	1.1	-	-		
			3/4	20	3/4	22	3/4	22	1 1/8	37	1 3/4	44	1 3/4	41	2	51	2.7	1.2	-	-		
	1		25	1 1/16	17	1	25	1 1/8	37	1 3/4	44	1 3/4	41	2	51	2.7	1.2	-	-			
	1 1/4		32	1 3/8	22	1 1/8	22	1 1/8	37	1 3/4	44	1 3/4	41	2	51	2.5	1.1	-	-			
	1 1/2		40	1 5/16	24	1 1/4	32	1 1/2	38	2	51	1 3/4	48	2 1/8	54	3.1	1.4	-	-			
	2		50	1 3/8	40	1 1/8	37	1 3/8	40	2 1/4	57	2 1/4	52	2 1/4	57	3.7	1.7	-	-			

See additional sizes on previous and following page. Note: See page PF-75 for pressure-temperature ratings.

# Cast Iron Threaded Fittings Class 125, (Standard)



Reducing Tee: Figure 359

Size		A		B		C		D		E		F		Wt.											
NPS	Dn	NPS	DN	NPS	DN	in	mm	in	mm	in	mm	in	mm	in	mm	in	mm	lbs	kg	lbs	kg				
2 1/2	65	1/2	15	2	50	1 1/16	40	1 1/16	43	1 1/8	48	2 1/16	62	2 1/4	54	2 3/16	65	5.3	2.4	-	-				
				2 1/2	65	1 3/16	47	1 3/16	47	1 3/8	47	2 1/16	68	2 1/4	57	2 1/16	68	5.2	2.4	-	-				
		3/4	20	2 1/2	65	1 3/16	47	1 3/4	44	1 3/8	47	2 1/16	68	2 1/4	57	2 1/16	68	5.1	2.3	-	-				
				2	50	1 3/16	40	1 3/8	44	1 3/8	47	2 1/16	68	2 1/4	57	2 1/16	68	5.0	2.3	-	-				
		1	25	2	50	1 3/16	40	1 3/8	44	1 3/8	47	2 1/16	68	2 3/16	59	2 1/16	68	5.4	2.4	-	-				
				2 1/2	65	1 3/16	47	1 3/4	44	1 3/8	47	2 1/16	68	2 3/16	49	2 1/16	62	4.3	1.9	-	-				
		1 1/4	32	1 1/2	40	1 5/16	24	1 5/16	24	1 3/8	47	2 3/16	56	1 5/16	49	2 3/16	65	5.0	2.2	-	-				
				2	50	1 3/16	40	1 1/2	38	1 1/2	48	2 3/16	62	2 1/4	54	2 3/16	68	5.4	2.4	-	-				
		1 1/2	40	2 1/2	65	1 3/16	47	1 3/4	44	1 3/8	47	2 3/16	56	1 5/16	49	2 3/16	62	4.2	1.9	-	-				
				1 1/2	40	1 5/16	24	1 5/16	24	1 3/8	48	2 3/16	62	2 1/4	54	2 3/16	65	4.8	2.2	-	-				
		3	80	1/2	15	2	50	1 3/16	40	1 1/2	38	1 1/2	48	2 3/16	62	2 1/4	54	2 3/16	68	5.8	2.6	-	-		
						2 1/2	65	1 3/16	47	1 3/8	44	1 3/8	47	2 3/16	68	2 3/16	62	2 3/16	68	5.8	2.6	-	-		
				3/4	20	1 1/2	40	1 5/16	24	1 5/16	22	1 3/4	44	1 1/16	43	1 1/2	38	2 3/16	56	3.6	1.6	-	-		
						1 1/4	32	1 3/16	22	1 3/16	22	1 3/4	44	1 3/4	44	1 3/16	40	2 3/16	57	3.6	1.6	-	-		
				1	25	1	25	1	25	1 1/16	17	1 3/4	44	1 15/16	49	1 3/4	44	2 5/16	59	3.9	1.8	-	-		
						1 1/4	32	1 3/16	22	1 3/16	22	1 3/4	44	2 3/16	52	1 1/2	48	2 3/16	60	4.3	1.9	-	-		
				1 1/4	32	1 1/2	40	1 5/16	24	1 5/16	24	1 3/8	47	2 3/16	56	2	51	2 3/16	62	4.4	2.0	-	-		
						2	50	1 3/16	40	1 3/8	40	1 3/8	48	2 3/16	62	2 1/4	57	2 3/16	65	5.2	2.3	-	-		
				1 1/2	40	2 1/2	65	1 3/16	47	1 1/2	48	1 3/8	47	2 1/16	68	2 3/16	65	2 3/16	68	6.0	2.7	-	-		
						1 1/2	40	1 5/16	24	1 5/16	24	1 3/8	47	2 3/16	56	2 3/16	56	2 3/16	62	5.1	2.3	-	-		
				3	80	2	50	1 1/2	40	1 3/8	35	1 1/2	38	2 3/16	56	2 3/16	65	2 1/4	57	2 1/16	75	7.3	3.3	-	-
								2	50	1 3/16	40	1 3/8	40	2 3/16	56	2 3/16	65	2 3/16	65	3 1/16	78	7.1	3.2	-	-
						2 1/2	65	3	80	2 3/16	54	2 3/16	56	2 3/16	54	3 1/4	79	2 1/16	75	3 3/16	79	8.8	4.0	-	-
								1	25	1	25	1 1/16	24	2 1/4	54	2 3/16	52	1 5/16	49	2 1/16	68	5.5	2.5	-	-
2 1/2	65					1 1/4	32	1 3/4	32	1 3/8	22	2 1/2	54	2 3/16	56	2 3/16	52	2 3/16	70	5.9	2.7	-	-		
						1 1/2	40	1 3/8	35	1 5/16	24	2 3/16	56	2 3/16	59	2 3/16	56	2 3/16	73	6.2	2.8	6.3	2.9		
2 1/2	65					2	50	1 3/16	40	1 1/2	38	2 3/16	56	2 3/16	65	2 1/16	62	2 1/16	75	6.8	3.1	-	-		
						2 1/2	65	1 3/8	48	1 3/8	47	2 1/2	54	2 3/16	73	2 1/16	68	3 1/16	78	7.7	3.5	-	-		
3	80					3	80	1 1/2	40	1 3/8	35	1 1/2	38	2 3/16	56	2 3/16	65	2 1/4	57	2 1/16	75	7.3	3.3	-	-
								3	80	2 3/16	54	2 3/16	54	2 1/2	54	3 1/4	79	2 3/16	75	3 3/16	79	8.8	4.0	-	-
						3 1/2	90	1 1/2	40	1 3/8	35	1 3/8	35	2 3/16	56	2 3/16	59	2 3/16	59	2 3/16	75	7.1	3.2	7.3	3.3
								2 1/2	65	1 3/8	48	1 3/8	48	2 1/2	54	2 3/16	73	2 3/16	73	3 1/16	78	8.9	4.0	9.0	4.1
						4	100	3 1/2	90	2 3/16	50	2 3/16	60	2 3/16	56	3 3/8	86	3 3/8	86	3 3/16	81	11	5.0	-	-
								4	100	2 11/16	68	2 11/16	68	2 1/16	62	3 11/16	94	3 11/16	94	3 1/2	89	13	5.8	-	-
		5	125			3 1/2	90	2 3/16	50	2 3/16	60	2 3/16	56	3 3/8	86	3 3/8	86	3 3/16	81	11	5.0	-	-		
						5	125	3 3/8	86	3 3/8	84	2 1/16	65	4 1/16	110	4 3/16	110	3 3/4	95	20	9	-	-		

See additional sizes on previous and following page. Note: See page PF-75 for pressure-temperature ratings.



# Cast Iron Threaded Fittings Class 125, (Standard)

Reducing Tee: Figure 359

Size		A		B		C		D		E		F		Wt.									
														black		galv.							
NPS	Dn	NPS	DN	NPS	DN	in	mm	in	mm	in	mm	in	mm	in	mm	in	mm	lbs	kg	lbs	kg		
3/2	90	1/4	32	3	80	2 3/16	56	2 1/2	64	2 3/4	60	3 3/16	81	3 3/8	79	3 3/8	86	13	5.7	-	-		
		2	50	3 1/2	90	2 7/16	62	2 7/16	62	2 7/16	62	3 7/16	87	3 7/16	84	3 7/16	87	13	5.9	-	-		
		2 1/2	65	2 1/2	65	1 15/16	49	1 15/16	49	2 3/8	60	2 3/8	60	3 1/8	81	3	76	3 3/8	84	12	5.3	-	-
				3	80	2 1/16	56	2 1/8	52	2 3/8	60	2 3/8	60	3 1/8	87	3 1/8	84	3 1/8	87	13	5.7	-	-
				3 1/2	90	2 7/16	62	2 3/8	60	2 7/16	62	2 7/16	62	3 1/16	87	3 1/16	84	3 1/16	87	13	5.7	-	-
				4	100	2 11/16	68	2 5/8	67	2 1/2	64	3 1/16	94	3 11/16	94	3 1/2	89	15	6.9	-	-		
		3	80	1 1/2	40	1 3/8	35	1 3/8	35	2 7/16	62	2 5/8	67	2 7/16	65	3 3/16	81	3 3/16	81	8.7	3.9	-	-
				2	50	1 5/8	41	1 7/8	40	2 7/16	62	2 5/8	67	2 7/16	65	3 3/16	81	3 3/16	81	8.7	3.9	-	-
				2 1/2	65	1 15/16	49	1 7/8	48	2 3/8	60	2 7/8	73	2 13/16	73	3 5/16	84	10.0	4.5	-	-		
				3	80	2 3/16	56	2 3/8	54	2 3/8	60	3 3/16	81	3 3/8	79	3 3/8	86	11	5.1	-	-		
				3 1/2	90	2 7/16	62	2 3/8	60	2 7/16	62	3 7/16	87	3 3/8	87	3 3/16	87	14	6.3	-	-		
		3 1/2	90	4	100	2 11/16	68	2 11/16	68	2 1/2	64	3 1/16	94	3 11/16	94	3 1/2	89	15	6.9	-	-		
				5	125	3 5/16	84	3 5/16	84	2 7/8	65	4 7/16	110	4 5/16	110	3 3/4	95	20	9	-	-		
				1	25	1 1/16	17	1 1/16	17	2 3/4	60	2 1/2	54	2 1/4	54	2 15/16	75	8.0	3.6	-	-		
				1 1/4	32	1 1/4	32	1 1/4	32	2 3/4	60	2 1/4	57	2 1/4	57	3	76	8.6	3.9	-	-		
				1 1/2	40	1 3/8	35	1 3/8	35	2 7/16	62	2 3/8	60	2 3/8	60	3 1/16	78	8.9	4.0	-	-		
				2	50	1 5/8	41	1 5/8	41	2 7/16	62	2 5/8	67	2 5/8	67	3 3/16	81	9.9	4.5	-	-		
				2 1/2	65	1 15/16	49	1 15/16	49	2 3/8	60	2 3/8	67	2 3/8	73	2 3/8	73	3 5/16	84	11	5.0	-	-
				3	80	2 1/16	56	2 3/16	56	2 3/8	60	3 5/16	81	3 7/16	81	3 3/8	86	12	5.4	-	-		
		4	100	2 7/16	68	2 11/16	68	2 1/2	64	3 1/16	94	3 7/16	94	3 1/2	89	14	6.5	-	-				
5	125	3 5/16	84	3 5/16	84	2 7/8	65	4 7/16	110	4 5/16	110	3 3/4	95	20	9	-	-						

See additional sizes on previous and following page. Note: See page PR-75 for pressure-temperature ratings.

# Cast Iron Threaded Fittings Class 125, (Standard)



Reducing Tee: Figure 359

Size		A		B		C		D		E		F		Wt.											
														black		galv.									
														ins	kg	lbs	kg								
NPS	Dn	NPS	DN	NPS	DN	in	mm	in	mm	in	mm	in	mm	in	mm	ins	kg	lbs	kg						
4	100	1/4	20	4	100	2 3/4	70	3	76	2 3/4	70	3 3/4	95	3 1/2	89	3 3/4	95	13	6.0	-	-				
			1	25	4	100	2 3/4	70	2 15/16	75	2 3/4	70	3 3/4	95	3 1/2	89	3 3/4	95	14	6.1	-	-			
			1 1/4	32	4	100	2 3/4	70	2 1/2	73	2 3/4	70	3 3/4	95	3 1/2	89	3 3/4	95	14	6.5	-	-			
			1 1/2	40	4	100	2 3/4	70	2 1/2	73	2 3/4	70	3 3/4	95	3 1/2	89	3 3/4	95	13	6.1	-	-			
		2	50	1/2	2	50	1 11/16	43	1 7/8	48	2 3/4	70	2 11/16	68	2 3/8	65	2 3/8	65	3 1/2	89	11	5.1	-	-	
					2 1/2	65	1 3/4	48	1 7/8	48	2 3/4	67	2 15/16	75	2 3/8	73	3 1/8	90	12	5.3	-	-			
					3	80	2 1/4	57	2 1/16	62	2 11/16	68	3 3/4	83	3 3/4	79	3 3/4	95	13	6.1	-	-			
					4	100	2 3/4	70	2 3/4	70	2 3/4	70	3 3/4	95	3 1/2	89	3 3/4	95	13	6.0	-	-			
				2 1/2	65	2 1/2	65	1 3/4	48	1 13/16	47	2 3/4	67	2 3/4	70	3 3/4	83	3 3/4	79	3 3/4	95	12	5.3	-	-
						3	80	2 1/4	57	2 1/4	54	2 11/16	68	3 3/4	83	3 3/4	79	3 3/4	95	13	5.9	-	-		
						4	100	2 3/4	70	2 3/4	70	2 3/4	70	3 3/4	95	3 3/4	92	3 3/4	95	16	7.1	-	-		
						5	125	3 3/8	86	3 1/2	89	2 13/16	73	4 3/8	111	4 3/8	111	4	102	22	10	-	-		
		3	80	1 1/4	32	1 5/16	24	1 5/16	24	2 3/4	67	2 5/8	59	2 1/4	57	3 5/16	84	9.7	4.4	-	-				
				1 1/2	40	1 7/16	37	1 7/16	37	2 11/16	68	2 7/8	62	2 3/4	60	3 5/16	84	10	4.6	-	-				
				2	50	1 11/16	43	1 7/8	40	2 3/4	70	2 11/16	68	2 3/8	65	3 1/2	89	10	4.6	11	4.8				
				2 1/2	65	1 3/4	48	1 7/8	48	2 3/4	67	2 15/16	75	2 3/8	73	3 3/8	90	11	5.1	-	-				
		3 1/2	90	3	80	2 1/4	57	2 1/4	54	2 11/16	68	3 3/4	83	3 3/4	79	3 3/4	95	15	6.8	-	-				
				4	100	2 3/4	70	2 11/16	68	2 3/4	70	3 3/4	95	3 3/4	92	3 3/4	95	15	6.8	-	-				
				1 1/2	40	1 7/16	37	1 3/8	35	2 11/16	68	2 11/16	68	2 3/8	62	2 3/4	60	3 5/16	84	10	4.6	-	-		
				2	50	1 11/16	43	1 3/8	41	2 3/4	70	2 11/16	68	2 3/8	62	2 3/4	60	3 5/16	84	10	4.6	-	-		
		4	100	3 1/2	2 1/2	65	2	51	1 15/16	49	2 3/4	67	3	76	2 3/4	73	3 3/8	90	12	5.4	-	-			
					3	80	2 1/4	57	2 3/8	56	2 11/16	68	3 3/4	83	3 3/4	83	3 3/8	92	15	6.6	-	-			
					3 1/2	90	2 1/2	64	2 1/8	62	2 11/16	68	3 3/4	89	3 3/8	87	3 11/16	94	14	6.5	-	-			
					4	100	2 3/4	70	2 11/16	68	2 3/4	70	3 3/4	95	3 3/4	95	3 3/4	95	17	7.8	-	-			
				4	100	5	125	3 3/8	86	3 3/8	84	2 13/16	73	4 3/8	111	4 3/8	111	4	102	21	9	-	-		
						1 1/4	32	1 5/16	24	1 1/4	32	2 11/16	73	2 5/8	59	2 3/8	59	3 3/8	84	11	4.8	-	-		
						1 1/2	40	1 7/16	37	1 3/8	37	2 11/16	68	2 3/8	59	2 3/8	59	3 3/8	84	10	4.7	11	4.8		
						1 3/4	48	1 9/16	43	1 3/8	43	2 3/4	70	2 3/8	59	2 3/8	59	3 3/8	84	11	4.9	11	5.1		
		5	125	4	2	50	1 11/16	43	1 11/16	43	2 3/4	70	2 11/16	68	2 3/8	62	2 11/16	68	3 1/2	89	12	5.3	12	5.3	
					2 1/2	65	2	51	2	51	2 3/4	67	2 3/8	62	2 3/8	62	2 11/16	68	3 1/2	89	12	5.3	12	5.3	
					3	80	2 1/4	57	2 1/4	57	2 11/16	68	3 3/4	83	3 3/4	83	3 3/8	92	14	6.4	15	6.7			
					5	125	3 3/8	86	3 3/8	86	2 13/16	73	4 3/8	111	4 3/8	111	4	102	21	9	-	-			
				5	125	3 1/2	90	2 3/4	70	2 11/16	68	2 3/4	70	3 3/4	95	3 3/4	95	3 3/4	95	17	7.8	-	-		
						4	100	2 3/4	70	2 11/16	68	2 3/4	70	3 3/4	95	3 3/4	95	3 3/4	95	17	7.8	-	-		
						4 1/2	112.5	3 1/4	84	3 1/4	84	2 13/16	73	4 3/8	111	4 3/8	111	4	102	21	9	-	-		
						5	125	3 3/8	86	3 3/8	86	2 13/16	73	4 3/8	111	4 3/8	111	4	102	21	9	-	-		
		5	125	5	2 1/2	65	2 1/8	52	2	51	3 3/8	81	3 3/8	81	3 3/8	81	3 3/8	81	4 1/4	108	24	11	-	-	
					3	80	2 3/8	59	2 1/8	62	3 3/4	86	4	102	3 3/4	89	4 1/4	108	24	11	-	-			
					4	100	2 3/4	71	2 3/4	70	3 3/8	86	4	102	3 3/4	95	4 3/4	111	21	9	-	-			
					5	125	3 3/8	84	3 3/8	86	3 5/8	84	4 1/2	114	4 3/4	111	4 3/4	114	26	12	-	-			
5	125			6	150	3 13/16	97	3 3/8	98	3 3/8	86	5	127	5	127	4 3/4	117	34	15	-	-				
				1 1/2	40	1 3/8	40	1 3/8	40	3 1/8	84	2 11/16	68	2 11/16	68	4	102	16	7.4	-	-				
				2	50	1 3/4	44	1 3/4	44	3 1/8	87	2 15/16	75	2 15/16	75	4 1/8	105	17	7.9	-	-				
				2 1/2	65	2 1/8	52	2 1/8	52	3 3/8	86	3 3/8	81	3 3/8	81	4 1/4	108	19	8.5	-	-				
5	125	3	80	2 5/8	59	2 5/8	59	3 3/4	83	3 1/2	89	3 1/2	89	4 1/4	108	20	9.1	-	-						
		4	100	2 3/4	71	2 3/4	71	3 3/8	86	4	102	4	102	4 3/4	111	24	11	-	-						
		6	150	3 13/16	97	3 13/16	97	3 3/8	86	5	127	5	127	4 3/4	117	33	15	-	-						
		8	200	5 7/16	132	5 7/16	132	4 3/8	106	6 3/4	162	6 3/4	162	5 3/8	141	68	31	-	-						

See additional sizes on previous and following page. Note: See page PF-75 for pressure-temperature ratings.

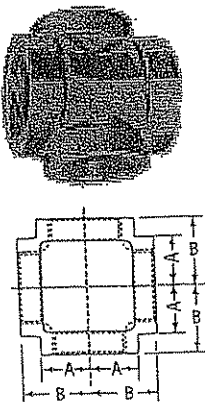


## Cast Iron Threaded Fittings Class 125, (Standard)

Reducing Tee: Figure 359

Size		A		B		C		D		E		F		Wt.										
														black		galv.								
NPS	Dn	NPS	DN	NPS	DN	in	mm	in	mm	in	mm	in	mm	in	mm	in	mm	lbs	kg	lbs	kg			
6	150	1½	40	6	150	3¾	98	4½	103	3¾	98	5½	130	4½	119	5½	130	35	16	-	-			
		2	50	6	150	3¾	98	4	102	3¾	98	5½	130	4½	119	5½	130	35	16	-	-			
		2½	65	6	150	3¾	98	3½	97	3¾	98	5½	130	4½	119	5½	130	35	16	-	-			
		3	80	4	100	2½	71	3	76	3¾	98	4½	103	4	102	4½	119	125	32	15	-	-		
		3½	90	6	150	3¾	98	3¾	98	3¾	98	5½	130	4½	119	5½	130	35	16	-	-			
		4	100	3	80	2½	59	2½	64	3¾	98	3¾	98	3¾	90	3¾	90	4½	119	125	30	14	-	-
				4	100	2½	73	2½	75	3¾	98	4½	103	4	102	4½	119	5½	130	34	16	-	-	
				6	150	3¾	98	3¾	98	3¾	98	5½	130	4½	119	5½	130	34	16	-	-			
			5	125	1½	40	1½	41	1½	40	3¾	98	2½	70	2½	70	4½	114	26	12	-	-		
					3½	90	2½	67	2½	65	3½	97	3¾	98	3¾	95	4½	124	30	14	-	-		
					6	150	3¾	98	3½	100	3¾	98	5½	130	5½	130	5½	130	43	20	-	-		
		6	150	8	200	5½	130	5½	132	4½	106	6½	162	6½	162	5½	141	66	30	-	-			
	1½			32	1½	35	1½	35	3½	97	2½	67	2½	67	4½	113	22	10	-	-				
	2			50	1½	46	1½	46	3¾	98	3	76	3	76	4½	117	25	11	-	-				
	2½			65	2	51	2	51	3¾	97	3¼	83	3¼	83	4½	121	26	12	27	12				
	3			80	2½	60	2½	60	3¾	97	3¾	90	3¾	90	4½	103	32	15	34	15				
	4			100	2½	73	2½	73	3¾	98	4½	103	4½	103	5	127	37	17	-	-				
	8	200	5	125	3¾	86	3¾	86	3½	97	4½	117	4½	117	5	127	37	17	-	-				
			8	200	5½	130	5½	130	4½	106	6½	162	6½	162	5½	141	58	26	-	-				
			2	50	5½	132	5½	149	5½	132	6½	167	6½	167	6½	167	64	29	-	-				
			4	100	5½	132	5½	140	5½	132	6½	167	6½	167	6½	167	67	30	-	-				
			5	125	4½	106	4½	111	5½	132	5½	141	5½	141	6½	162	77	35	-	-				
			6	150	4½	106	4½	110	5½	130	5½	141	5½	141	6½	162	74	33	-	-				
		B	200	8	200	5½	132	5½	130	5½	132	6½	167	6½	167	6½	167	67	30	-	-			
2				50	2½	52	2½	52	5½	130	3½	87	3½	87	5½	149	44	20	-	-				
2½				65	2½	59	2½	59	5½	129	3½	94	3½	94	6	152	45	21	-	-				
3				80	3¾	79	3¾	79	5½	130	4½	114	4½	114	6½	156	54	25	-	-				
3½				90	3¾	79	3¾	79	5½	130	4½	114	4½	114	6½	156	54	24	-	-				
4				100	3¾	79	3¾	79	5½	130	4½	114	4½	114	6½	156	54	24	-	-				
5	125	4½	106	4½	106	5½	132	5½	141	5½	141	6½	162	68	31	-	-							
6	150	4½	106	4½	106	5½	130	5½	141	5½	141	6½	162	66	30	-	-							

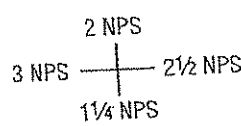
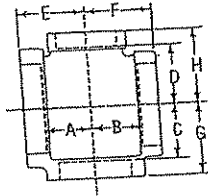
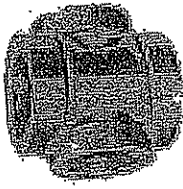
See additional sizes on previous page. Note: See page PF-75 for pressure-temperature ratings.

Straight Cross Figure 360	Size		A		B		Weight black	
	NPS	Dn	in	mm	in	mm	lbs	kg
	½	15	¾	22	¾	14	2.8	1.3
	¾	20	1½	33	1½	22	1.0	0.47
	1	25	1½	38	1½	24	1.6	0.72
	1½	32	1½	44	1½	29	2.4	1.1
	1½	40	1½	49	1½	33	3.2	1.5
	2	50	2¼	57	1½	40	5.1	2.3
	2½	65	2½	68	1½	47	8.1	3.7
	3	80	3¾	79	2½	56	12	5.4
	4	100	3¾	98	2½	70	20	8.9
	5	125	4½	114	3½	84	31	14
	6	150	5½	130	3½	98	48	22

# Cast Iron Threaded Fittings Class 125, (Standard)



Reducing Cross  
Figure 361



Read as:  
3 x 2 1/2 x 2 x 1 1/4



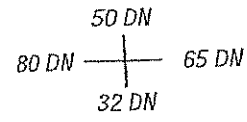
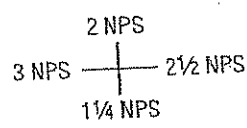
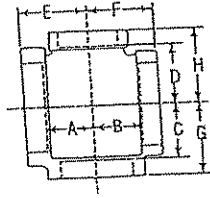
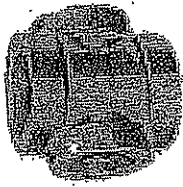
Read as:  
80 x 65 x 50 x 32

Size						A		B		C		D		E, F		G, H		Weight					
NPS	DN	NPS	DN	NPS	DN	NPS	DN	in	mm	in	mm	in	mm	in	mm	in	mm	in	mm	lbs	kg		
1	25	1	25	3/4	20	3/4	20	1 1/16	22	1 1/16	22	1 1/16	24	1 1/16	24	1 3/8	35	1 1/16	37	1.3	0.59		
1 1/4	32	1 1/4	32	1	25	1	25	1 1/16	24	1 1/16	24	1 1/4	29	1 1/4	29	1 1/16	40	1 1/16	43	2.0	0.9		
1 1/2	40	1 1/4	32	1	25	1	25	1	25	1 1/4	29	1 1/4	32	1 1/4	32	1 1/8	41	1 1/16	47	2.7	1.2		
				1	25	1	25	1	25	1 1/4	32	1 1/4	32	1 1/4	32	1 1/8	41	1 1/16	47	2.7	1.2		
		1 1/2	40	1	25	1	25	1 1/8	29	1 1/2	29	1 1/8	29	1 1/8	24	1 1/16	47	1 1/8	48	3.9	1.8		
				1 1/4	32	1 1/4	32	1 1/8	29	1 1/4	29	1 1/2	35	1 1/8	35	1 1/16	47	1 1/8	48	4.0	1.8		
2	50	1 1/2	40	1	25	1	25	1 1/8	29	1 1/2	29	1 1/16	37	1 1/16	37	1 1/4	44	2	51	3.6	1.6		
				1 1/4	32	1	25	1 1/8	29	1 1/4	29	1 1/16	37	1 1/8	48	2 1/8	54	4.3	1.9				
				1 1/4	32	1 1/4	32	1 1/8	29	1 1/4	29	1 1/2	38	1 1/8	48	2 1/8	54	4.2	1.9				
				1	25	1	25	1 1/16	17	1 1/16	17	1 1/16	37	1 1/16	37	1 1/8	48	2 1/8	54	4.0	1.8		
		2	50	1 1/4	32	1 1/4	32	1 1/8	29	1 1/4	29	1 1/16	37	1 1/16	37	2	51	2 1/8	54	4.1	1.9		
				1 1/2	40	1 1/2	40	1 1/8	29	1 1/4	29	1 1/16	37	1 1/16	37	2 1/16	52	2 1/8	60	6.0	2.7		
				1 1/4	32	1 1/4	32	1 1/8	29	1 1/4	29	1 1/16	37	1 1/16	37	2 1/16	52	2 1/8	60	6.0	2.7		
				1 1/2	40	1 1/2	40	1 1/8	29	1 1/4	29	1 1/16	37	1 1/16	37	2 1/16	52	2 1/8	60	6.0	2.7		
2 1/2	65	1 1/2	40	1	25	1	25	1 1/8	29	1 1/2	29	1 1/8	48	1 1/16	47	1 1/16	49	2 1/16	59	5.1	2.3		
				1	25	1	25	1 1/8	29	1 1/2	29	1 1/8	48	1 1/16	47	1 1/16	49	2 1/16	59	5.1	2.3		
				1 1/4	32	1 1/4	32	1 1/8	29	1 1/4	29	1 1/16	37	1 1/16	37	2 1/16	52	2 1/8	60	5.9	2.7		
				1 1/2	40	1 1/2	40	1 1/8	29	1 1/4	29	1 1/16	37	1 1/16	37	2 1/16	52	2 1/8	60	5.9	2.7		
		2	50	1 1/4	32	1 1/4	32	1 1/8	29	1 1/4	29	1 1/16	37	1 1/16	37	2 1/16	52	2 1/8	60	5.9	2.7		
				1 1/4	32	1 1/4	32	1 1/8	29	1 1/4	29	1 1/16	37	1 1/16	37	2 1/16	52	2 1/8	60	5.9	2.7		
				1 1/2	40	1 1/2	40	1 1/8	29	1 1/4	29	1 1/16	37	1 1/16	37	2 1/16	52	2 1/8	60	5.9	2.7		
				2	50	2	50	1 1/2	38	1 1/4	44	1 1/4	48	1 1/4	48	2 1/16	59	2 1/16	65	7.2	3.3		
		2 1/2	65	2 1/2	65	1	25	1	25	1 1/8	29	1 1/2	29	1 1/8	48	1 1/16	47	1 1/16	49	2 1/16	59	5.1	2.3
						1 1/4	32	1 1/4	32	1 1/8	29	1 1/4	29	1 1/16	37	1 1/16	37	2 1/16	52	2 1/8	60	5.4	2.4
						1 1/2	40	1 1/2	40	1 1/8	29	1 1/4	29	1 1/16	37	1 1/16	37	2 1/16	52	2 1/8	60	5.3	2.4
						2	50	2	50	1 1/2	38	1 1/4	44	1 1/4	48	1 1/4	48	2 1/16	59	2 1/16	65	7.2	3.3
				2 1/2	65	1 1/4	32	1 1/4	32	1 1/8	29	1 1/4	29	1 1/16	37	1 1/16	37	2 1/16	52	2 1/8	60	5.4	2.4
						1 1/4	32	1 1/4	32	1 1/8	29	1 1/4	29	1 1/16	37	1 1/16	37	2 1/16	52	2 1/8	60	5.3	2.4
						1 1/2	40	1 1/2	40	1 1/8	29	1 1/4	29	1 1/16	37	1 1/16	37	2 1/16	52	2 1/8	60	5.3	2.4
						2	50	2	50	1 1/2	38	1 1/4	44	1 1/4	48	1 1/4	48	2 1/16	59	2 1/16	65	7.2	3.3
3	80	2 1/2	65	1	25	1	25	1 1/8	29	1 1/2	29	1 1/8	48	1 1/16	47	1 1/16	49	2 1/16	59	5.1	2.3		
				1 1/2	40	1 1/2	40	1 1/8	29	1 1/4	29	1 1/16	37	1 1/16	37	2 1/16	52	2 1/8	60	5.4	2.4		
				2	50	2	50	1 1/2	38	1 1/4	44	1 1/4	48	1 1/4	48	2 1/16	59	2 1/16	65	7.2	3.3		
				2 1/2	65	2 1/2	65	1 1/8	29	1 1/4	29	1 1/16	37	1 1/16	37	2 1/16	52	2 1/8	60	5.4	2.4		
		3	80	3	80	1 1/4	32	1 1/4	32	1 1/8	29	1 1/4	29	1 1/16	37	1 1/16	37	2 1/16	52	2 1/8	60	5.3	2.4
						1 1/2	40	1 1/2	40	1 1/8	29	1 1/4	29	1 1/16	37	1 1/16	37	2 1/16	52	2 1/8	60	5.3	2.4
						1 1/2	40	1 1/2	40	1 1/8	29	1 1/4	29	1 1/16	37	1 1/16	37	2 1/16	52	2 1/8	60	5.3	2.4
						2	50	2	50	1 1/2	38	1 1/4	44	1 1/4	48	1 1/4	48	2 1/16	59	2 1/16	65	7.2	3.3
				3	80	1 1/4	32	1 1/4	32	1 1/8	29	1 1/4	29	1 1/16	37	1 1/16	37	2 1/16	52	2 1/8	60	5.4	2.4
						1 1/2	40	1 1/2	40	1 1/8	29	1 1/4	29	1 1/16	37	1 1/16	37	2 1/16	52	2 1/8	60	5.3	2.4
						1 1/2	40	1 1/2	40	1 1/8	29	1 1/4	29	1 1/16	37	1 1/16	37	2 1/16	52	2 1/8	60	5.3	2.4
						2	50	2	50	1 1/2	38	1 1/4	44	1 1/4	48	1 1/4	48	2 1/16	59	2 1/16	65	7.2	3.3
3 1/2	90	3	80	1	25	1	25	1 1/8	29	1 1/2	29	1 1/8	48	1 1/16	47	1 1/16	49	2 1/16	59	5.1	2.3		
				1 1/2	40	1 1/2	40	1 1/8	29	1 1/4	29	1 1/16	37	1 1/16	37	2 1/16	52	2 1/8	60	5.4	2.4		
				2	50	2	50	1 1/2	38	1 1/4	44	1 1/4	48	1 1/4	48	2 1/16	59	2 1/16	65	7.2	3.3		
				3 1/2	90	3 1/2	90	1 1/8	29	1 1/4	29	1 1/16	37	1 1/16	37	2 1/16	52	2 1/8	60	5.4	2.4		
		3 1/2	90	3 1/2	90	1 1/4	32	1 1/4	32	1 1/8	29	1 1/4	29	1 1/16	37	1 1/16	37	2 1/16	52	2 1/8	60	5.3	2.4
						1 1/2	40	1 1/2	40	1 1/8	29	1 1/4	29	1 1/16	37	1 1/16	37	2 1/16	52	2 1/8	60	5.3	2.4
						1 1/2	40	1 1/2	40	1 1/8	29	1 1/4	29	1 1/16	37	1 1/16	37	2 1/16	52	2 1/8	60	5.3	2.4
						2	50	2	50	1 1/2	38	1 1/4	44	1 1/4	48	1 1/4	48	2 1/16	59	2 1/16	65	7.2	3.3
				3 1/2	90	1 1/4	32	1 1/4	32	1 1/8	29	1 1/4	29	1 1/16	37	1 1/16	37	2 1/16	52	2 1/8	60	5.3	2.4
						1 1/2	40	1 1/2	40	1 1/8	29	1 1/4	29	1 1/16	37	1 1/16	37	2 1/16	52	2 1/8	60	5.3	2.4
						1 1/2	40	1 1/2	40	1 1/8	29	1 1/4	29	1 1/16	37	1 1/16	37	2 1/16	52	2 1/8	60	5.3	2.4
						2	50	2	50	1 1/2	38	1 1/4	44	1 1/4	48	1 1/4	48	2 1/16	59	2 1/16	65	7.2	3.3
4	100	3	80	1	25	1	25	1 1/8	29	1 1/2	29	1 1/8	48	1 1/16	47	1 1/16	49	2 1/16	59	5.1	2.3		
				1 1/2	40	1 1/2	40	1 1/8	29	1 1/4	29	1 1/16	37	1 1/16	37	2 1/16	52	2 1/8	60	5.4	2.4		
				2	50	2	50	1 1/2	38	1 1/4	44	1 1/4	48	1 1/4	48	2 1/16	59	2 1/16	65	7.2	3.3		
				3 1/2	90	3 1/2	90	1 1/8	29	1 1/4	29	1 1/16	37	1 1/16	37	2 1/16	52	2 1/8	60	5.4	2.4		
		4	100	4	100	1 1/4	32	1 1/4	32	1 1/8	29	1 1/4	29	1 1/16	37	1 1/16	37	2 1/16	52	2 1/8	60	5.3	2.4
						1 1/2	40	1 1/2	40	1 1/8	29	1 1/4	29	1 1/16	37	1 1/16	37	2 1/16	52	2 1/8	60	5.3	2.4
						1 1/2	40	1 1/2	40	1 1/8	29	1 1/4	29	1 1/16	37	1 1/16	37	2 1/16	52	2 1/8	60	5.3	2.4
						2	50	2	50	1 1/2	38	1 1/4	44	1 1/4	48	1 1/4	48	2 1/16	59	2 1/16	65	7.2	3.3
				4																			



# Cast Iron Threaded Fittings Class 125, (Standard)

Reducing Cross  
Figure 361



Read as:  
3 x 2 1/2 x 2 x 1 1/4

Read as:  
80 x 65 x 50 x 32

Size								A		B		C		D		E, F		G, H		Weight			
NPS	DN	NPS	DN	NPS	DN	NPS	DN	in	mm	in	mm	in	mm	in	mm	in	mm	in	mm	lbs	kg		
5	125	4	100	1 1/2	40	1 1/2	40	1 1/2	38	1 1/2	41	3 3/4	86	3 3/8	86	2 1 1/2	68	4	102	19	8.5		
				2 1/2	65	2	50	2	51	2 1/2	54	3 5/16	84	3 3/16	90	3 3/16	81	4 1/4	108	22	10		
		5	125	2	50	2	50	1 3/4	44	1 3/4	44	3 7/16	87	3 3/16	87	2 1 1/2	75	4 1/8	105	18	8.3		
				3	80	3	80	2 5/16	59	2 5/16	59	3 5/16	84	3 5/16	84	3 1/2	89	4 5/16	110	23	10		
				6	150	1 1/2	40	1 1/2	40	1 1/2	38	1 1/2	40	3 3/4	98	3 3/8	98	2 3/4	70	4 1/2	114	26	12
						2	50	2	50	1 3/4	44	1 13/16	47	3 1 1/2	100	3 1 1/2	100	3	76	4 3/8	117	28	13
6	150	6	150	1 1/4	32	1 1/4	32	1 1/2	35	1 1/2	35	3 1 1/2	98	3 1 1/2	98	2 3/4	67	4 1/8	113	23	10		
				2 1/2	65	2 1/2	65	2	51	2	51	3 3/4	98	3 3/8	98	3 3/4	83	4 3/4	121	26	12		
		8	200	4	100	4	100	2 1 1/2	73	2 1 1/2	73	3 3/4	98	3 3/8	98	4 1/8	103	4 1 1/2	125	33	15		
				5	125	5	125	3 3/4	86	3 3/4	86	3 1 1/2	98	3 3/8	98	4 5/8	117	5	127	39	18		
				5	125	5	125	3 3/4	86	3 3/4	86	3 1 1/2	98	3 3/8	98	4 5/8	117	5	127	39	18		
8	200	8	200	4	100	4	100	3 3/4	79	3 3/4	79	5 1/8	129	5 1/8	129	4 1/2	114	6 1/4	156	56	25		
				5	125	5	125	4 3/8	106	4 3/8	106	5 3/8	132	5 3/8	132	5 1 1/2	141	6 3/4	162	80	36		



Note: See page PF-75 for pressure-temperature ratings. See additional sizes on previous page.


Lateral Figure 373	Size)		A		B		C		D		Weight black	
	NPS	DN	in	mm	in	mm	in	mm	in	mm	lbs	kg
	3/4	20	3/4	6	1 1/4	44	3/4	19	2 1/4	57	1.00	0.45
	1	25	3/8	5	2 3/16	56	3/4	19	2 3/4	70	1.6	0.73
	1 1/4	32	3/8	10	2 5/8	67	1	25	3 3/4	83	2.6	1.2
	1 1/2	40	1/2	11	3 3/16	81	1 1/8	27	3 1 1/2	98	3.6	1.6
	2	50	3/8	14	3 1 1/2	98	1 1/4	32	4 1/2	114	5.8	2.6
	2 1/2	65	5/8	16	4 5/16	110	1 1/2	38	5 1/8	132	9.0	4.1
	3	80	1 1/8	22	5 5/16	132	1 3/4	44	6 1/4	156	14	6.1
	4	100	1 1/2	27	6 3/8	167	2 1/4	54	7 1/8	194	21	10

Note: See page PF-75 for pressure-temperature ratings.


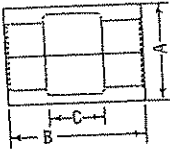
# Cast Iron Threaded Fittings Class 125, (Standard)




Return Bends Close Pattern, R.H. Figure 375	Size		Center to Center		Weight black		Return Bends Open Figure 376	Size		Center to Center		Weight black	
	NPS	DN	in	mm	lbs	kg		NPS	DN	in	mm	lbs	kg
	1/2	15	1 1/4	32	0.65	0.29		1/2	15	1 1/2	38	—	—
	3/4	20	1 1/2	38	1.1	0.50		3/4	20	1 1/4	48	0.98	0.44
	1	25	1 3/4	44	1.7	0.78		1	25	2 1/2	64	1.5	0.67
	1 1/4	32	2 1/4	57	2.4	1.1		1 1/4	32	3	76	2.4	1.1
	1 1/2	40	2 1/2	64	3.5	1.6		1 1/2	40	3 1/4	89	3.3	1.5



Special Wide Pattern Figure 377	Size		Center to Center		Weight			
	NPS	DN	in	mm	black		galv.	
	1	25	4	102	lbs	kg	lbs	kg
	1 1/4	32	4	102	2.2	1.0	•	•
	1 1/4	32	6	152	3.5	1.6	•	•
*Not stocked								

Note: See page PF-75 for pressure-temperature ratings.



Hex Coupling Figure 366	Size		Across Flats A		B		C		Weight black	
	NPS	DN	in	mm	in	mm	in	mm	lbs	kg
 	1	25	1 1/8	49	1 1/8	43	3/8	14	0.82	0.37

Flange Union Gasket Type Figure 487	Size		Diam. of Flanges		No. of bolts	Weight			
	NPS	DN	in	mm		black		galv.	
						lbs	kg	lbs	kg
Assembled with gaskets 	1/2	15	2 1/8	75	3	1.8	0.79	1.8	0.82
	3/4	20	3	76	3	2.0	0.91	2.0	0.9
	1	25	3 1/4	83	3	2.3	1.0	2.3	1.0
	1 1/4	32	4 1/8	106	4	4.8	2.2	4.8	2.2
	1 1/2	40	4 1/2	111	4	5.0	2.3	5.1	2.3
	2	50	5	127	4	6.5	2.9	6.7	3.0
	2 1/2	65	5 1/2	143	4	8.5	3.9	8.7	3.9
	3	80	6 1/2	162	4	11	5.0	11	5.1
	3 1/2	90	6 3/4	175	4	13	5.8	13	5.9
	4	100	7 1/8	195	5	18	8.2	19	8.4
	5	125	8 1/8	227	5	22	10	23	10
6	150	10 1/4	260	6	30	14	31	14	
8	200	12 1/8	329	8	51	23	53	24	

## Cast Iron Threaded Fittings Class 125, (Standard)

Concentric Reducers Figure 367											
 				Size		A		B		Weight black	
				NPS	DN	NPS	DN	in	mm	in	mm
3/4	20	1/2	15	5/8	16	1 1/16	40	0.40	0.18		
1	25	1/2	15	1 1/16	17	1 1/16	43	0.54	0.24		
		3/4	20	1/2	11	1 1/2	38	0.63	0.29		
1 1/4	32	1/2	15	3/8	14	1 3/4	41	0.84	0.38		
		3/4	20	1	25	2 1/4	54	1.1	0.49		
1	25	1	25	1 1/16	24	2 1/4	54	1.1	0.49		
		1 1/4	32	1	25	2 1/4	57	1.5	0.66		
1 1/2	40	1/2	15	1/2	13	1 3/4	41	1.00	0.45		
		3/4	20	1/2	13	1 3/4	41	1.2	0.54		
1	25	1	25	1/2	13	1 3/4	44	1.5	0.68		
		1 1/4	32	1	25	2 1/4	57	1.5	0.66		
2	50	1/2	15	5/8	16	2	51	2.0	0.91		
		3/4	20	3/4	19	2	51	1.9	0.86		
1	25	1	25	3/4	19	2	51	1.8	0.83		
		1 1/4	32	1 1/16	22	2 1/4	54	1.8	0.81		
1 1/2	40	1 1/2	40	1/2	22	2 3/16	56	2.0	0.90		
		2	50	1	25	2 3/16	65	3.0	1.4		
2 1/2	65	1 1/2	40	3/4	19	2	51	3.1	1.4		
		2	50	1	25	2 3/16	65	3.0	1.4		
3	80	3/4	20	1 1/16	24	2 1/2	64	4.3	2.0		
		2	50	1 1/16	27	2 3/4	70	4.0	1.8		
2 1/2	65	2 1/2	65	1 5/16	24	2 13/16	73	4.4	2.0		
		4	100	2	50	2 13/16	75	6.5	2.9		
4	100	2 1/2	65	1 3/8	30	2 15/16	75	6.5	2.9		
		3	80	1 1/2	27	3 1/4	79	7.0	3.2		
5	125	4	100	1 1/8	27	3 5/16	84	10	4.8		
6	150	4	100	1 1/4	29	3 1/8	87	14	6.3		
		5	125	1 1/2	29	3 1/8	90	16	7.0		
8	200	6	150	1 1/4	32	3 3/8	98	29	13		

hex end

Eccentric Reducer Figure 368													
 				Size		A		B *		Weight			
				NPS	DN	NPS	DN	in	mm	in	mm	black	
3/4	20	1/2	15	5/16	14	1 1/2	38	0.45	0.20	—	—		
1	25	1/2	15	1/2	13	1 1/16	37	0.57	0.26	•	•		
		3/4	20	1/16	11	1 1/2	38	0.61	0.28	—	—		
1 1/4	32	1/2	15	3/16	14	1 3/4	41	1.00	0.45	—	—		
		3/4	20	1/2	13	1 3/4	41	0.90	0.41	—	—		
1 1/2	40	1/2	15	1/2	13	1 11/16	43	1.00	0.45	•	•		
		3/4	20	1/16	14	1 11/16	43	1.2	0.53	—	—		
1	25	1	25	1/16	14	1 3/4	44	1.2	0.55	—	—		
		1 1/4	32	5/8	16	1 7/8	48	1.3	0.57	•	•		
2	50	1/2	15	3/4	19	1 15/16	49	1.8	0.82	—	—		
		3/4	20	3/4	19	2	51	1.8	0.83	—	—		
1	25	1	25	1 1/16	17	2 1/16	52	1.9	0.84	—	—		
		1 1/4	32	1 3/16	22	2 1/8	54	1.9	0.85	—	—		
1 1/2	40	1 1/2	40	7/8	22	2 3/8	56	1.9	0.88	•	•		
		2	50	1	25	2 3/8	65	3.0	1.3	•	•		
2 1/2	65	1	25	1 3/16	22	2 1/4	57	2.7	1.2	—	—		
		1 1/4	32	1/2	22	2 3/8	60	2.8	1.3	—	—		
1 1/2	40	1 1/2	40	1/2	22	2 3/8	60	2.9	1.3	—	—		
		2	50	1	25	2 3/8	65	3.0	1.3	•	•		
3	80	1	25	3/4	22	2 1/16	62	4.0	1.8	—	—		
		1 1/4	32	1 1/16	24	2 9/16	65	3.8	1.7	—	—		
1 1/2	40	1 1/2	40	1 1/16	24	2 9/16	65	4.2	1.9	—	—		
		2	50	1 1/16	27	2 3/4	70	4.6	2.1	—	—		
2 1/2	65	2 1/2	65	1 1/16	24	2 13/16	73	4.8	2.2	•	•		
		3	80	1 1/8	27	2 3/4	70	5.2	2.4	—	—		
3 1/2	90	2	50	1 1/8	27	2 3/4	70	5.2	2.4	—	—		
		3	80	1 1/8	24	2 15/16	75	6.0	2.7	•	•		
4	100	1	25	1 1/16	27	2 11/16	68	6.8	3.1	—	—		
		1 1/4	32	1 1/16	27	2 3/4	70	6.6	3.0	—	—		
1 1/2	40	1 1/2	40	1 1/4	29	2 13/16	73	6.6	3.0	—	—		
		2	50	1 1/16	30	2 15/16	75	6.9	3.1	—	—		
2 1/2	65	2 1/2	65	1 1/4	29	3 1/16	78	7.3	3.3	—	—		
		3	80	1 1/8	27	3 1/8	79	7.6	3.5	•	•		
2 1/2	65	2 1/2	65	1 1/2	29	3 3/16	81	11	5.2	—	—		
		3	80	1 1/8	27	3 1/4	83	11	5.2	—	—		
5	125	4	100	1 1/16	27	3 5/16	84	11	5.1	•	•		
		6	150	1 1/8	27	3 5/16	84	15	6.6	—	—		
6	150	3	80	1 1/8	27	3 5/16	84	15	6.6	—	—		
		4	100	1 1/4	29	3 7/16	87	15	7.0	•	•		
8	200	5	125	1 1/8	33	3 3/4	95	28	13	—	—		
		6	150	1 1/4	32	3 3/4	98	28	13	•	•		

\* Dimension "B" does not conform to ASME standard  
• Not stocked

Note: See page PF-75 for pressure-temperature ratings.

# Cast Iron Threaded Fittings Class 125, (Standard)



Hex Bushing  
Figure 383



Size		Weight						
NPS	Dn	Hex	NPS	Dn	black		galv.	
					lbs	kg	lbs	kg
1/4	8		1/4	6	0.02*	0.01*	0.02	0.01
3/8	10		3/8	6	0.05	0.02	0.05	0.02
			1/2	8	0.04	0.02	0.04	0.02
1/2	15		1/2	6	0.05	0.03	0.06	0.03
			3/4	8	0.07	0.03	0.07	0.03
			1	10	0.05	0.02	0.05	0.02
3/4	20		1/2	6	0.09	0.04	0.09	0.04
			3/4	8	0.10	0.05	0.11	0.05
			1	10	0.12	0.05	0.12	0.05
			1 1/2	15	0.10	0.05	0.11	0.05
1	25	■	1/2	6	0.21	0.09	0.22	0.10
		■	3/4	8	0.19	0.08	0.19	0.09
		■	1	10	0.18	0.08	0.19	0.09
			1 1/2	15	0.21	0.10	0.22	0.10
			2	20	0.17	0.08	0.17	0.08
1 1/4	32	■	1/2	8	0.29	0.13	0.30	0.14
		■	3/4	10	0.29	0.13	0.29	0.13
		■	1	15	0.30	0.14	0.30	0.14
			1 1/2	20	0.39	0.17	0.39	0.18
			2	25	0.30	0.13	0.30	0.14
1 1/2	40		1/2	8	0.47	0.21	0.49	0.22
		■	3/4	10	0.47	0.21	0.50	0.23
		■	1	15	0.42	0.19	0.47	0.21
		■	1 1/2	20	0.47	0.21	0.50	0.23
			2	25	0.50	0.23	0.52	0.24
			2 1/2	32	0.33	0.15	0.33	0.15
2	50		1/2	8	0.75	0.34	0.80	0.36
		■	3/4	10	0.75	0.34	0.78	0.35
		■	1	15	0.77	0.35	0.78	0.35
		■	1 1/2	20	0.71	0.32	0.75	0.34
		■	2	25	0.73	0.33	0.76	0.34
		■	2 1/2	32	0.81	0.37	0.83	0.38
			3	40	0.67	0.30	0.68	0.31
2 1/2	65		1/2	15	1.3	0.58	—	—
		■	3/4	20	1.3	0.57	1.3	0.59
		■	1	25	1.2	0.53	1.2	0.56
		■	1 1/2	32	1.2	0.56	1.3	0.57
			2	40	1.3	0.59	1.3	0.61
			2 1/2	50	0.92	0.42	0.95	0.43

Continued to next column

Hex Bushing  
Figure 383



Size		Weight						
NPS	Dn	Hex	NPS	Dn	black		galv.	
					lbs	kg	lbs	kg
3	80	■	1/2	15	1.9	0.88	2.0	0.9
		■	3/4	20	1.9	0.87	2.0	0.88
		■	1	25	1.9	0.86	1.9	0.87
		■	1 1/4	32	1.8	0.80	1.8	0.82
		■	1 1/2	40	1.8	0.81	1.8	0.83
			2	50	1.9	0.86	1.9	0.88
	2 1/2	65	1.6	0.74	1.7	0.75		
3 1/2	90	■	1	25	2.6	1.2	2.6	1.2
		■	1 1/4	32	2.5	1.2	2.6	1.2
		■	1 1/2	40	2.3	1.1	2.4	1.1
		■	2	50	2.4	1.1	2.5	1.1
			2 1/2	65	2.6	1.2	2.6	1.2
	3	80	2.0	0.89	2.0	0.90		
4	100	■	1	25	3.6	1.6	3.6	1.6
		■	1 1/4	32	3.5	1.6	3.6	1.6
		■	1 1/2	40	3.4	1.6	3.5	1.6
		■	2	50	3.1	1.4	3.2	1.5
		■	2 1/2	65	3.3	1.5	3.3	1.5
			3	80	3.1	1.4	3.2	1.5
	3 1/2	90	2.5	1.1	2.6	1.2		
5	125	■	2	50	5.1	2.3	5.2	2.4
		■	2 1/2	65	4.9	2.2	5.1	2.3
		■	3	80	4.8	2.2	4.9	2.2
			3 1/2	90	4.0	1.8	4.3	2.0
			4	100	3.9	1.8	4.1	1.9
6	150	■	2	50	8.0	3.6	8.3	3.8
		■	2 1/2	65	7.7	3.5	7.8	3.5
		■	3	80	7.8	3.5	8.1	3.7
		■	3 1/2	90	7.1	3.2	7.4	3.4
		■	4	100	6.8	3.1	7.1	3.2
			5	125	5.2	2.4	5.5	2.5
8	200	■	3	80	16	7.0	16	7.2
		■	4	100	14	6.3	15	6.8
		■	5	125	14	6.2	14	6.4
			6	150	13	6.0	14	6.1
10	250	■	4	100	28	12	—	—
		■	5	125	—	—	—	—
		■	6	150	25	11	—	—
			8	200	22	10	—	—
12	300		4	100	33	15	—	—
			10	250	33	15	33	15


- Not stocked
- Inside hex
- \*P.D.A.

Note: Hexagon head or octagon head bushings 2 1/2 NPS (65 DN) and smaller reducing one size may be made of malleable iron, ductile iron or steel. Other sizes may be made of cast iron, ductile iron, malleable iron or steel. Face bushings 2 1/2 NPS (65 DN) and smaller may be made of malleable iron, ductile iron or steel. Face bushings 3 NPS (80 DN) and larger reducing one size may be made of malleable iron, ductile iron or steel. Face bushings 3 NPS (80 DN) and larger reducing two sizes or more may be made of cast or malleable iron, ductile iron, or steel.


According to specifications, hex bushings and cored plugs should be used with 150# malleable iron and 125# cast iron. Solid plugs and face bushings should be used with #250 and #300 fittings.  
Note: See page PF-57 and page PF-75 for pressure-temperature ratings. Pressure/temperature ratings vary with material




## Cast Iron Threaded Fittings Class 125, (Standard)

Face Bushing Figure 385	Size				Weight			
					black		galv.	
	NPS	DN	NPS	DN	lbs	kg	lbs	kg
	1/4	8	1/4	6	0.01*	0.00*	—	—
	3/8	10	1/4	8	0.02*	0.01*	—	—
	1/2	15	1/4	8	0.04*	0.02*	—	—
			3/8	10	0.03*	0.01*	—	—
	3/4	20	3/8	10	0.07*	0.03*	0.07	0.03
			1/2	15	0.06	0.02	0.06	0.02
	1	25	1/2	15	0.12	0.05	0.13	0.06
			3/4	20	0.08	0.04	0.09	0.04
			1/2	15	0.25*	0.11*	—	—
	1 1/4	32	3/4	20	0.27*	0.12*	—	—
			1	25	0.16	0.07	0.17	0.07
			1	25	0.32	0.15	0.33	0.15
	1 1/2	40	1/2	15	0.39*	0.18*	0.40	0.18
			3/4	20	0.34	0.15	0.35	0.16
			1	25	0.34	0.15	0.35	0.16
			1 1/4	32	0.15	0.07	0.15	0.07
	2	50	1/2	15	0.68*	0.32*	—	—
			1	25	0.53	0.24	0.54	0.24
			1 1/4	32	0.54	0.24	0.55	0.25
			1 1/2	40	0.34	0.16	0.35	0.16
	2 1/2	65	1 1/4	32	0.94*	0.42*	0.96*	0.44*
			1 1/2	40	0.85*	0.39*	0.87*	0.39*
			2	50	0.62	0.28	0.62	0.28
	3	80	1 1/4	32	1.5	0.70	—	—
1 1/2			40	1.5	0.68	1.6	0.71	
2			50	1.3	0.60	1.4	0.63	
2 1/2			65	0.97	0.44	1.0	0.46	
3 1/2	90	2 1/2	65	1.8	0.80	—	—	

\* PDA

Locknut Figure 370	Size		Minimum Dimensions								Weight			
			A		B		C		D		black		galv.	
	NPS	DN	in	mm	in	mm	in	mm	in	mm	lbs	kg	lbs	kg
	2 1/2	65	3.500	89	3.180	81	.590	15	.090	2	1.1	0.51	1.2	0.53
	3	80	4.270	108	3.840	98	.670	17	.090	2	1.6	0.73	1.7	0.77
	4	100	5.380	137	5.000	127	.800	20	.130	3	3.5	1.6	—	—

Floor Flange Bolt Holes Cored Figure 1006	Size		Diameter of Flange		No. of Holes	Diameter of Holes		Weight			
								black		galv.	
	NPS	DN	in	mm	in	mm	lbs	kg	lbs	kg	
	1/4	8	2 1/16	73	4	1/4	6	0.39	0.18	0.40	0.18
	3/8	10	3	76	4	1/4	6	0.43	0.20	0.45	0.20
	1/2	15	3 1/2	89	4	1/4	6	0.73	0.33	0.74	0.34
	3/4	20	3 1/2	89	4	1/4	6	0.80	0.36	0.81	0.37
	1	25	4	102	4	1/4	6	1.1	0.51	1.1	0.52
	1 1/4	32	4	102	4	1/4	6	1.1	0.52	1.1	0.52
	1 1/2	40	4 1/2	114	4	3/16	8	1.6	0.70	1.6	0.71
	2	50	5 1/2	140	4	3/16	8	2.4	1.1	2.4	1.1

Note: See page PF-57 and page PF-75 for pressure-temperature ratings.

# Cast Iron Threaded Fittings Class 125, (Standard)



Square Head Plugs (Cored) Figure 3870	Size		Weight			
			black		galv.	
	NPS	DN	lbs	kg	lbs	kg
	3/4	20	0.13	0.06	0.14	0.06
	1	25	0.25	0.11	0.28	0.13
	1 1/4	32	0.39	0.18	0.41	0.18
	1 1/2	40	0.50	0.23	0.52	0.23
	2	50	0.81	0.37	0.83	0.38
	2 1/2	65	1.3	0.60	1.3	0.61
	3	80	1.9	0.85	1.9	0.87
	3 1/2	90	2.5	1.1	2.6*	1.2*
	4	100	4.0	1.8	4.0	1.8

Countersunk Plugs Figure 390A	Size		Weight			
			black		galv.	
	NPS	DN	lbs	kg	lbs	kg
	1/2	15	0.05	0.02	0.05	0.02
	3/4	20	0.09	0.04	0.10*	0.05*
	1	25	0.20	0.09	0.20	0.09
	1 1/4	32	0.32	0.15	0.34	0.15
	1 1/2	40	0.47	0.21	0.48	0.22
	2	50	0.84	0.38	1.3	0.59
	2 1/2	65	1.4	0.64	2.0	0.91
	3	80	2.3	1.0	3.0	1.4
	3 1/2	90	3.0	1.4	—	—
	4	100	3.8	1.7	3.9	1.8

Square Head Plugs (Solid) Figure 388	Size		Weight			
			black		galv.	
	NPS	DN	lbs	kg	lbs	kg
	1/2	15	0.10	0.05	0.10	0.05
	3/4	20	0.17	0.08	0.18	0.08
	1	25	0.32	0.15	0.33	0.15
	1 1/4	32	0.53	0.24	0.55	0.25
	1 1/2	40	0.76	0.34	0.77	0.35
	2	50	1.2	0.56	1.3	0.57
	2 1/2	65	2.0	0.91	2.1	0.9
	3	80	3.2	1.4	3.3	1.5
	3 1/2	90	4.4	2.0	•	•

Cap Figure 381	Size		Weight			
			black		galv.	
	NPS	DN	lbs	kg	lbs	kg
	2 1/2	65	2.5	1.2	—	—
	3	80	4.1	1.9	—	—
	4	100	6.4	2.9	—	—
	5	125	11	4.9	—	—
	6	150	14	6.4	15	6.6
	8	200	27	12	28	13

Bar Plugs Cored Figure 389	Size		Weight			
			black		galv.	
	NPS	DN	lbs	kg	lbs	kg
	4	100	3.8	1.7	4.0	1.8
	5	125	6.5	2.9	6.8	3.1
	6	150	9.9	4.5	10	4.7
	8	200	20	9	21	10
Bar Plugs Solid Figure 380	Size		Weight			
			black		galv.	
	NPS	DN	lbs	kg	lbs	kg
	4	100	5.7	2.6	•	•
	5	125	9.6	4.4	•	•
	6	150	15	6.7	•	•
	8	200	•	•	•	•

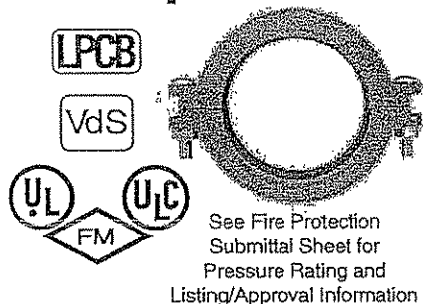
◊ 1/8, 1/4, 3/8 NPS (6, 8 & 10 DN) plugs furnished in steel  
 s 1/2 and 3/4 NPS (15 & 20 DN) countersunk plugs furnished in  
 malleable iron  
 • Not stocked

Note: See page PF-75 for pressure-temperature ratings.

\* POA

## Grinnell Grooved Fire Protection Products Figure 772 Rigid Coupling - Patented

### General Description



The Figure 772 Rigid Coupling provides a rigid joint by firmly gripping along the circumference of the pipe grooves. Rigid couplings are preferred for dry pipe and freezer applications. Figure 772 Rigid Couplings are a proven dependable method of joining pipe and are an economical alternative to welding, threading or using flanges. It is capable of pressures up to 500 psig (3447 kPa) depending on pipe size and wall thickness when used in fire protection services.

Rigid Couplings are recommended for dry pipe and freezer applications.

#### WARNING

The Figure 772 Rigid Coupling described herein must be installed and maintained in compliance with this document, as well as with the applicable standards of the National Fire Protection Association, in addition to the standards of any other authorities having jurisdiction. Failure to do so may impair the performance of this device.

The owner is responsible for maintaining their fire protection system and devices in proper operating condition. The installing contractor or sprinkler manufacturer should be contacted with any questions.

### Technical Data

Figure: 772

Sizes: 1½" - 12"

Approvals: UL, FM, ULC, VdS, and LPCB;  
See Fire Protection Submittal Sheet for exact Listing / Approval information.

**Housing:** Ductile iron conforming to ASTM A-536, Grade 65-45-12

**Protective Coatings:**

- Non-lead orange paint
- Fire brigade red (optional) non-lead paint
- Hot dipped galvanized conforming to ASTM A-153

**Bolt/Nuts:** Track Head Bolts - conforming to ASTM A-183, Zinc Plated, (Min. Tensile = 110,000 psi/758,422 kPa)

Metric - conforming to ASTM F568M

**Gasket:** (specify when ordering)

- Grade "A" EPDM violet color code ambient to +150°F (+66°C) for fire protection systems. Not recommended for hot water systems.
- Tri-seal (Grade "E" EPDM), green color code for use in dry pipe or freezer systems.
- Prelubricated (Grade "A" EPDM)

(See Data Sheet TFP1895 for aid in selecting proper gasket)

### Ordering Procedure

When placing an order, indicate the full product name. Please specify the quantity, figure number, type of gasket, Grade "A" EPDM, Prelubricated (Grade "A" EPDM) or Grade "E" EPDM Tri-Seal, and size.

Grinnell Grooved Piping Products, valves, accessories and other products are available throughout the U.S., Canada, and internationally, through a network of distribution centers. You may write directly or call 215-362-0700 for the distributor nearest you.

### Care and Maintenance

The owner is responsible for the inspection, testing, and maintenance of their fire protection system and devices in accordance with the applicable standards of the National Fire Protection Association (e.g., NFPA 25), in addition to the standards of any authority having jurisdiction. The installing contractor or product manufacturer

should be contacted relative to any questions. Any impairment must be immediately corrected. It is recommended that automatic sprinkler systems be inspected, tested, and maintained by a qualified Inspection Service.

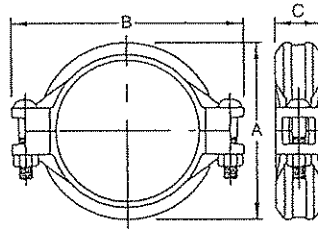
### Limited Warranty

Products manufactured by Tyco Fire Products are warranted solely to the original Buyer for ten (10) years against defects in material and workmanship when paid for and properly installed and maintained under normal use and service. This warranty will expire ten (10) years from date of shipment by Tyco Fire Products. No warranty is given for products or components manufactured by companies not affiliated by ownership with Tyco Fire Products or for products and components which have been subject to misuse, improper installation, corrosion, or which have not been installed, maintained, modified or repaired in accordance with applicable Standards of the National Fire Protection Association (NFPA), and/or the standards of any other Authorities Having Jurisdiction. Materials found by Tyco Fire Products to be defective shall be either repaired or replaced, at Tyco Fire Products' sole option. Tyco Fire Products neither assumes, nor authorizes any person to assume for it, any other obligation in connection with the sale of products or parts of products. Tyco Fire Products shall not be responsible for sprinkler system design errors or inaccurate or incomplete information supplied by Buyer or Buyer's representatives.

IN NO EVENT SHALL TYCO FIRE PRODUCTS BE LIABLE, IN CONTRACT, TORT, STRICT LIABILITY OR UNDER ANY OTHER LEGAL THEORY, FOR INCIDENTAL, INDIRECT, SPECIAL OR CONSEQUENTIAL DAMAGES, INCLUDING BUT NOT LIMITED TO LABOR CHARGES, REGARDLESS OF WHETHER TYCO FIRE PRODUCTS WAS INFORMED ABOUT THE POSSIBILITY OF SUCH DAMAGES, AND IN NO EVENT SHALL TYCO FIRE PRODUCTS' LIABILITY EXCEED AN AMOUNT EQUAL TO THE SALES PRICE.

**THE FOREGOING WARRANTY IS MADE IN LIEU OF ANY AND ALL OTHER WARRANTIES EXPRESS OR IMPLIED, INCLUDING WARRANTIES OF MERCHANTABILITY AND FITNESS FOR A PARTICULAR PURPOSE.**

## Figure 772 Grooved Coupling



Pipe		Max.*‡	Max.†	Max.†	Nominal Dimensions			Bolt Size** Dia. x Lg.	Net Wt. Lbs. Kg.
Size	O.D. Inches mm	End Gap Inches mm	Pressure psi kPa	End Load Lbs. N	A Inches mm	B Inches mm	C Inches mm		
1¼"	1.660	0.06	300	649	2.75	4.38	1.81	¾" x 2¼"	1.0
	42.4	1.5	2,068	2,887	69.9	111.3	46.0		
1½"	1.900	0.08	500	1,417	3.00	4.62	1.81	¾" x 2¼"	1.0
	48.3	2.0	3,447	6,303	76.2	117.3	46.0		
2"	2.375	0.13	500	2,214	3.41	5.12	1.88	¾" x 2¼"	1.5
	60.3	3.3	3,447	9,848	86.6	130.0	47.8		
2½"	2.875	0.13	500	3,244	3.91	5.63	1.88	¾" x 2¼"	2.5
	73.0	3.3	3,447	14,430	99.3	143.0	47.8		
76.1mm	3.000	0.13	300	2,120	4.19	5.72	2.00	M10 x 57	2.6
	76.1	3.3	2,068	9,430	106.4	145.3	50.8		
3"	3.500	0.13	500	4,808	4.63	6.25	1.88	¾" x 2¼"	2.6
	88.9	3.3	3,447	21,387	117.6	158.8	47.8		
4"	4.500	0.19	500	7,948	5.81	7.50	1.97	¾" x 2¼"	3.5
	114.3	4.8	3,447	35,353	147.6	190.5	50.0		
139.7mm	5.500	0.19	300	7,127	7.02	9.72	2.06	M16 x 83	7.5
	139.7	4.8	2,068	31,701	178.3	246.9	52.3		
5"	5.563	0.19	300	7,288	7.09	9.71	2.04	¾" x 3¼"	7.5
	141.3	4.8	2,068	32,417	180.1	246.6	51.8		
165.1mm	6.500	0.19	300	9,950	8.09	10.53	2.13	M16 x 83	7.6
	165.1	4.8	2,068	44,258	205.5	267.5	54.1		
6"	6.625	0.19	400	13,782	8.09	10.53	2.13	¾" x 3¼"	7.6
	168.3	4.8	2,758	61,302	205.5	267.5	54.1		
8"	8.625	0.19	450	26,278	10.56	13.56	2.62	¾" x 4¾"	18.0
	219.1	4.8	3,103	116,885	268.2	344.4	66.5		
10"	10.750	0.13	250	22,679	12.84	16.41	2.62	1" x 6½"	24.6
	273.0	3.3	1,724	100,876	326.1	416.8	66.5		
12"	12.750	0.13	250	31,903	15.41	18.84	2.62	1" x 6½"	42.0
	323.9	3.3	1,724	141,905	391.4	478.5	66.5		

\* Maximum available gap between pipe ends. Minimum gap = 0.

† Maximum pressure and end load are total from all loads based on standard weight steel pipe. Pressure ratings and end loads may differ on other pipe materials and/or wall thickness. Contact Tyco Fire Products for details. See Fire Protection Equipment Submittal Sheet for Listing and Approval pressure ratings.

\*\* Gold color coded metric bolt sizes are available upon request.

‡ Max End Gap is for cut grooved standard weight pipe. Values for roll grooved pipe will be ½ that of cut grooved.

Figure 772 Rigid Couplings have an Anti-Rotation Feature of "gripping teeth" along the coupling keys in sizes 1¼" - 4", which make the Figure 772 perfectly suited for "arm over" installations where the likelihood of rotation is greatest. This feature may eliminate the need of extra hangers to support the arm over due to increased rigidity and gripping force saving time and cost.

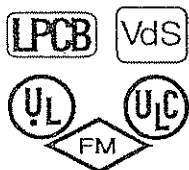
General Notes: It is the Designer's responsibility to select products suitable for the intended service and to ensure that pressure ratings and performance data is not exceeded. Always read and understand the installation instructions (IH-1000). Never remove any piping component or correct or modify any piping deficiencies without first depressurizing and draining the system. Material and gasket selection should be verified to be compatible for the specific application.



Certified Company

## Grinnell Grooved Fire Protection Products Grooved Fittings

### General Description



See Fire Protection  
Submittal Sheet for  
Pressure Rating and  
Listing/Approval  
Information

The grooved fittings provide an economical and efficient method of changing direction, adding an outlet, reducing, or capping grooved piping systems. Grooved fittings are available in durable ductile iron or fabricated steel as indicated.

**Note:** Figure 510S and 519S fittings are special short radius fittings with smaller center to end dimensions than standard grooved fittings. Depending on the size and coupling used, there may be interferences at the bolt pads that require repositioning of the coupling orientation. The use of flange adapters is not recommended with Figures 510S and 519S fittings. Contact Tyco Fire Products for details.

#### WARNING

*The Fittings described herein must be installed and maintained in compliance with this document, as well as with the applicable standards of the National Fire Protection Association, in addition to the standards of any other authorities having jurisdiction. Failure to do so may impair the performance of this device.*

*The owner is responsible for maintaining their fire protection system and devices in proper operating condition. The installing contractor or sprinkler manufacturer should be contacted with any questions.*

### Technical Data

#### Approvals:

UL, FM, ULC, VdS, and LPCB;

**Note:** See Fire Protection Submittal Sheet for exact Listing / Approval information.

#### Material:

Cast: Figures 201, 210, 219, 250, 260, 501, 510, 519, 510DE, 501S, 510S and 519S - Ductile iron conforming to ASTM A-536, Grade 65-45-12

Fabricated Steel: Figures 391, 392, 393, 312, 313, 321, 327, 341 and 350 - Carbon Steel, (Sizes 1 1/4" - 6" are Schedule 40); (Sizes 8" - 12" are Schedule 30), conforming to ASTM A-53 Grade B

#### Protective Coatings:

- Non-lead orange paint
- Fire brigade red (optional) non-lead paint
- Hot dipped galvanized conforming to ASTM A-153

### Ordering Procedure

When placing an order, indicate the full product name. Please specify the quantity, figure number, wall thickness, and size.

Grinnell Grooved Piping Products, valves, accessories and other products are available throughout the U.S., Canada, and internationally, through a network of distribution centers. You may write directly or call 215-362-0700 for the distributor nearest you.

### Care and Maintenance

The owner is responsible for the inspection, testing, and maintenance of their fire protection system and devices in accordance with the applicable standards of the National Fire Protection Association (e.g., NFPA 25), in addition to the standards of any authority having jurisdiction. The installing contractor or product manufacturer should be contacted relative to any questions. Any impairment must be immediately corrected. It is recommended that automatic sprinkler systems be inspected, tested, and maintained by a qualified Inspection Service.

### Limited Warranty

Products manufactured by Tyco Fire Products are warranted solely to the original Buyer for ten (10) years against defects in material and workmanship when paid for and properly installed and maintained under normal use and service. This warranty will expire ten (10) years from date of shipment by Tyco Fire Products. No warranty is given for products or components manufactured by companies not affiliated by ownership with Tyco Fire Products or for products and components which have been subject to misuse, improper installation, corrosion, or which have not been installed, maintained, modified or repaired in accordance with applicable Standards of the National Fire Protection Association (NFPA), and/or the standards of any other Authorities Having Jurisdiction. Materials found by Tyco Fire Products to be defective shall be either repaired or replaced, at Tyco Fire Products' sole option. Tyco Fire Products neither assumes, nor authorizes any person to assume for it, any other obligation in connection with the sale of products or parts of products. Tyco Fire Products shall not be responsible for sprinkler system design errors or inaccurate or incomplete information supplied by Buyer or Buyer's representatives.

IN NO EVENT SHALL TYCO FIRE PRODUCTS BE LIABLE, IN CONTRACT, TORT, STRICT LIABILITY OR UNDER ANY OTHER LEGAL THEORY, FOR INCIDENTAL, INDIRECT, SPECIAL OR CONSEQUENTIAL DAMAGES, INCLUDING BUT NOT LIMITED TO LABOR CHARGES, REGARDLESS OF WHETHER TYCO FIRE PRODUCTS WAS INFORMED ABOUT THE POSSIBILITY OF SUCH DAMAGES, AND IN NO EVENT SHALL TYCO FIRE PRODUCTS' LIABILITY EXCEED AN AMOUNT EQUAL TO THE SALES PRICE.

**THE FOREGOING WARRANTY IS MADE IN LIEU OF ANY AND ALL OTHER WARRANTIES EXPRESS OR IMPLIED, INCLUDING WARRANTIES OF MERCHANTABILITY AND FITNESS FOR A PARTICULAR PURPOSE.**

# Figures 201, 210, 219, and 260

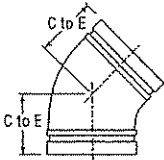


Figure 201

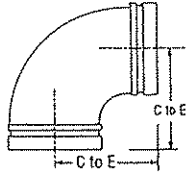


Figure 210

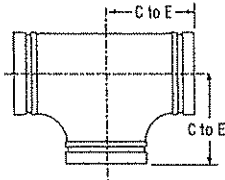


Figure 219

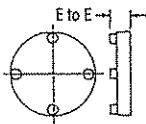


Figure 260

Nominal Size	Figure 201 45° Elbow		Figure 210 90° Elbow		Figure 219 Tee		Figure 260‡ End Cap	
	C to E Inches mm	Appx. Wt. Lbs. Kg.	C to E Inches mm	Appx. Wt. Lbs. Kg.	C to E Inches mm	Appx. Wt. Lbs. Kg.	E to E Inches mm	Appx. Wt. Lbs. Kg.
1 1/4"	1.75 44.5	0.9 0.4	2.75 69.9	1.0 0.5	2.75 69.9	1.4 0.6	0.88 22.4	0.4 0.2
1 1/2"	1.75 44.5	1.1 0.5	2.75 69.9	1.2 0.5	2.75 69.9	1.8 0.8	0.88 22.4	0.6 0.3
2"	2.00 50.8	1.8 0.8	3.25 82.6	2.0 0.9	3.25 82.6	2.7 1.2	0.88 22.4	0.9 0.4
2 1/2"	2.25 57.2	2.2 1.0	3.75 95.3	3.0 1.4	3.75 95.3	5.8 2.6	0.88 22.4	0.9 0.4
76.1mm	2.25 57.2	2.2 1.0	3.75 95.3	3.0 1.4	3.75 95.3	5.8 2.6	0.94 23.9	1.1 0.5
3"	2.50 63.5	3.5 1.6	4.25 108.0	4.5 2.0	4.25 108.0	7.0 3.2	0.88 22.4	1.1 0.5
108.0mm	2.88 73.0	5.5 2.5	4.75 120.7	8.5 3.9	4.75 120.7	11.5 5.2	-	-
4"	3.00 76.2	5.2 2.4	5.00 127.0	8.5 3.9	5.00 127.0	11.8 5.4	1.00 25.4	2.6 1.2
133.0mm	3.25 82.6	7.7 3.5	5.25 133.4	11.3 5.1	5.25 133.4	10.6 4.8	-	-
139.7mm	3.25 82.6	7.7 3.5	5.50 139.7	11.3 5.1	5.50 139.7	15.3 6.9	0.92 23.4	4.7 2.1
5"	3.25 82.6	8.5 3.9	5.50 139.7	13.5 6.1	5.50 139.7	17.0 7.7	1.00 25.4	5.0 2.3
159.0mm	3.50 88.9	12.0 5.4	6.00 152.4	14.6 6.6	6.00 152.4	13.9 6.3	-	-
165.1mm	3.50 88.9	12.0 5.4	6.50 165.1	18.5 8.4	6.50 165.1	26.0 11.8	1.00 25.4	7.5 3.4
6"	3.50 88.9	12.0 5.4	6.50 165.1	18.5 8.4	6.50 165.1	26.0 11.8	1.00 25.4	7.5 3.4
216.3mm	4.25 108.0	23.0 10.4	7.75 196.9	36.5 16.6	7.75 196.9	45.0 20.4	-	-
8"	4.25 108.0	23.0 10.4	7.75 196.9	36.5 16.6	7.75 196.9	45.0 20.4	1.19 30.2	12.8 5.8
10"	4.75 120.7	31.0 14.1	9.00 228.6	60.0 27.2	9.00 228.6	72.1 32.7	1.25 31.8	20.0 9.1
12"	5.25 133.4	40.0 18.1	10.00 254.0	67.0 30.4	10.00 254.0	92.5 42.0	1.25 31.8	36.0 16.3

‡ - Available with tapped plugs, contact Tyco Fire & Building Products.

Friction Resistance* (Expressed as Equivalent Straight Pipe)				
Size Inches mm	Elbow		Tee	
	90°	45°	Branch	Run
	Feet Meters	Feet Meters	Feet Meters	Feet Meters
1 1/4 42.4	1.9 0.6	1.0 0.3	4.8 1.5	1.9 0.6
1 1/2 48.3	2.3 0.7	1.2 0.4	5.8 1.8	2.3 0.7
2 60.3	3.2 1.0	1.6 0.5	8.0 2.5	3.2 1.0
2 1/2 73.0	3.9 1.2	2.0 0.6	9.8 3.0	3.9 1.2
76.1mm	4.1 1.2	2.1 0.6	10.3 3.1	4.1 1.2
3 88.9	4.9 1.5	2.4 0.7	12.2 3.7	4.9 1.5
108.0mm	6.5 2.0	3.3 1.0	16.3 5.0	6.5 2.0
4 114.3	6.5 2.0	3.3 1.0	16.3 5.0	6.5 2.0
133.0mm	8.0 2.4	4.0 1.2	20.0 6.1	8.0 2.4
139.7mm	8.0 2.4	4.1 1.3	20.0 6.1	8.0 2.4
5 141.3	8.2 2.5	4.1 1.3	20.5 6.3	8.2 2.5
159.0mm	9.5 2.9	4.8 1.4	23.8 7.2	9.5 2.9
165.1mm	9.5 2.9	4.8 1.4	23.8 7.2	9.5 2.9
6 168.3	9.9 3.0	5.0 1.5	24.8 7.5	9.9 3.0
216.3mm	13.1 4.0	6.6 2.0	32.8 10.0	13.1 4.0
8 219.1	13.1 4.0	6.6 2.0	32.8 10.0	13.1 4.0
10 273.0	16.5 5.0	8.3 2.5	41.3 12.6	16.5 5.0
12 323.4	19.9 6.1	9.9 3.0	49.7 15.1	19.9 6.1

For reducing tees and branches, use the value that is corresponding to the branch size. Example: for 8" x 8" x 2" tee, the branch value 2" is 8.0 feet.

\* Friction resistance for all elbows and tees except Figures 510S and 519S.

## Figures 501, 510, 519 and 510DE

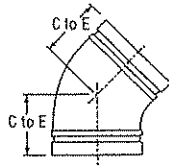


Figure 501

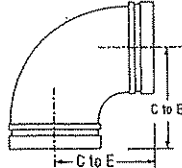


Figure 510

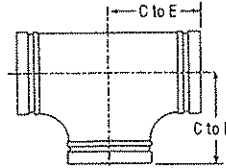


Figure 519

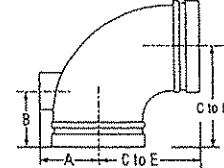


Figure 510DE

Nominal Size	Figure 501 45° Elbow		Figure 510 90° Elbow		Figure 519 Tee		Figure 510DE 90° Drain Elbow			
	C to E Inches mm	Appx. Wt. Lbs. Kg.	C to E Inches mm	Appx. Wt. Lbs. Kg.	C to E Inches mm	Appx. Wt. Lbs. Kg.	C to E Inches mm	A Inches mm	B Inches mm	Appx. Wt. Lbs. Kg.
1 1/4"	1.75 44.5	0.9 0.4	2.75 69.9	1.0 0.5	2.75 69.9	1.4 0.6	-	-	-	-
1 1/2"	1.75 44.5	1.1 0.5	2.75 69.9	1.2 0.5	2.75 69.9	1.8 0.8	-	-	-	-
2"	2.00 50.8	1.8 0.8	3.25 82.6	2.0 0.9	3.25 82.6	2.7 1.2	-	-	-	-
2 1/2"	2.25 57.2	2.2 1.0	3.75 95.3	3.0 1.4	3.75 95.3	5.8 2.6	3.75 95.3	2.00 50.8	2.75 69.9	2.7 1.2
3"	2.50 63.5	3.5 1.6	4.25 108.0	4.5 2.0	4.25 108.0	7.0 3.2	4.25 108.0	2.34 59.4	2.75 69.9	3.7 1.7
4"	3.00 76.2	5.2 2.4	5.00 127.0	8.5 3.9	5.00 127.0	11.8 5.4	5.00 127.0	2.85 72.4	2.75 69.9	7.0 3.2
5"	3.25 82.6	8.5 3.9	5.50 139.7	13.5 6.1	5.50 139.7	17.0 7.7	5.50 139.7	3.38 85.9	2.75 69.9	13.0 5.9
6"	3.50 88.9	12.0 5.4	6.50 165.1	18.5 8.4	6.50 165.1	26.0 11.8	6.50 165.1	3.92 99.6	2.75 69.9	13.4 6.1
8"	4.25 108.0	23.0 10.4	7.75 196.9	36.5 16.6	7.75 196.9	45.0 20.4	7.75 196.9	4.95 125.7	2.75 69.9	26.3 11.9

## Figures 501S, 510S and 519S

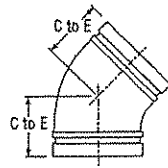


Figure 501S

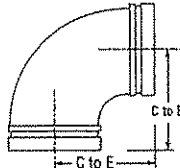


Figure 510S\*

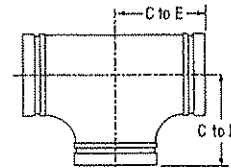


Figure 519S\*

Friction Resistance 501S, 510S & 519S (Expressed as Equivalent Straight Pipe)				
Size Inches mm	Elbow		Tee	
	90° Feet Meters	45° Feet Meters	Branch Feet Meters	Run Feet Meters
2 60.3	3.2 1.0	1.6 0.5	8.0 2.5	3.2 1.0
2 1/2 73.0	3.9 1.2	2.0 0.6	9.8 3.0	3.9 1.2
76.1mm	4.1 1.2	2.1 0.6	10.3 3.1	4.1 1.2
3 88.9	4.9 1.5	2.4 0.7	12.2 3.7	4.9 1.5
4 114.3	6.5 2.0	3.3 1.0	16.3 5.0	6.5 2.0
139.7mm	8.0 2.4	4.1 1.3	20.0 6.1	8.0 2.4
5 141.3	8.2 2.5	4.1 1.3	20.5 6.3	8.2 2.5
165.1mm	9.5 2.9	4.8 1.4	23.8 7.2	9.5 2.9
6 168.3	9.9 3.0	5.0 1.5	24.8 7.6	9.9 3.0
8 219.1	13.1 4.0	6.6 2.0	32.8 10.0	13.1 4.0

Nominal Size	Figure 501S 45° Elbow		Figure 510S 90° Elbow		Figure 519S Tee	
	C to E Inches mm	Appx. Wt. Lbs. Kg.	C to E Inches mm	Appx. Wt. Lbs. Kg.	C to E Inches mm	Appx. Wt. Lbs. Kg.
2"	2.00 50.8	1.8 0.8	2.75 69.9	1.5 0.7	2.75 69.9	2.1 1.0
2 1/2"	2.25 57.2	2.2 1.0	3.00 76.2	2.2 1.0	3.00 76.2	3.0 1.4
76.1mm	2.25 57.2	2.2 1.0	3.00 76.2	2.3 1.0	3.00 76.2	3.1 1.4
3"	2.50 63.5	3.5 1.6	3.38 85.9	3.0 1.3	3.38 85.9	4.1 1.9
4"	3.00 76.2	5.2 2.4	4.00 101.6	5.6 2.6	4.00 101.6	7.7 3.5
139.7mm	3.25 82.6	7.7 3.5	4.88 124.0	8.6 3.9	4.88 124.0	12.0 5.4
5"	3.25 82.6	8.5 3.9	4.88 124.0	8.8 3.9	4.88 124.0	12.0 5.4
165.1mm	3.50 88.9	12.0 5.4	5.50 139.7	11.00 5.0	5.50 139.7	15.0 6.8
6"	3.50 88.9	12.0 5.4	5.50 139.7	11.2 5.1	5.50 139.7	15.2 6.9
8"	4.25 108.0	23.0 10.4	6.88 174.8	23.4 10.6	6.88 174.8	31.2 14.2

\*Note: Figure 510S and 519S fittings are special short radius fittings with smaller center to end dimensions than standard proved fittings. Depending on the size and coupling used, there may be interferences at the bolt pads which requires repositioning of the coupling orientation. The use of flange adapters is not recommended with Figures 510S and 519S fittings. Contact Tyco Fire Products for details.

# Figures 250 and 350

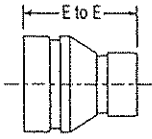


Figure 250  
Cast

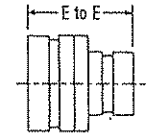


Figure 350  
Fabricated  
Sizes 3" to 6"

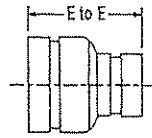
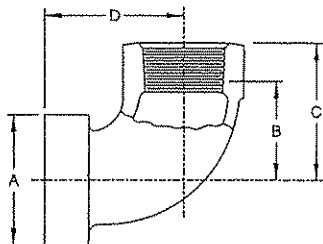


Figure 350  
Fabricated  
Sizes 8" to 12"

Figures 250 and 350 Concentric Reducer - Groove x Groove								
Nominal Size Inches	E to E Inches mm	Appx. Wt. Lbs. Kg.	Nominal Size Inches	E to E Inches mm	Appx. Wt. Lbs. Kg.	Nominal Size Inches	E to E Inches mm	Appx. Wt. Lbs. Kg.
*2 x 1¼	2.50 63.5	1.0 0.5	*139.7mm x 3	3.50 88.9	4.2 1.9	*6 x 5	4.00 101.6	5.8 2.6
*2 x 1½	2.50 63.5	1.3 0.6	*139.7mm x 4	3.50 88.9	4.4 2.0	8 x 2	5.00 127.0	12.2 5.5
*2½ x 2	2.50 63.5	1.2 0.5	5 x 1½	3.50 88.9	4.6 2.1	8 x 2½	5.00 127.0	12.1 5.5
*76.1mm x 1½	2.50 63.5	1.5 0.7	5 x 2	3.50 88.9	4.6 2.1	8 x 3	5.00 127.0	12.0 5.5
*76.1mm x 2	2.50 63.5	1.6 0.8	5 x 2½	3.50 88.9	4.5 2.0	8 x 4	5.00 127.0	11.9 5.4
3 x 1¼	2.50 63.5	1.3 0.6	5 x 3	3.50 88.9	4.4 2.0	8 x 5	5.00 127.0	11.3 5.1
3 x 1½	2.50 63.5	1.3 0.6	*5 x 4	3.50 88.9	4.5 2.0	8 x 6	5.00 127.0	10.8 4.9
*3 x 2	2.50 63.5	1.3 0.6	*165.1mm x 3	4.00 101.6	5.5 2.5	10 x 4	6.00 152.4	21.9 10.0
*3 x 2½	3.00 76.2	1.5 0.7	*165.1mm x 4	4.00 101.6	6.0 2.7	10 x 5	6.00 152.4	21.6 9.8
*3 x 76.1mm	3.00 76.2	2.0 0.9	*165.1mm x 139.7mm	4.00 101.6	5.6 2.5	10 x 6	6.00 152.4	21.1 9.6
4 x 1¼	3.00 76.2	2.2 1.0	*6 x 2	4.00 101.6	6.0 2.7	10 x 8	6.00 152.4	19.5 8.9
4 x 1½	3.00 76.2	2.3 1.0	6 x 2½	4.00 101.6	6.0 2.7	12 x 4	7.00 177.8	28.0 12.7
*4 x 2	3.00 76.2	2.3 1.0	*6 x 76.1mm	4.00 101.6	6.0 2.7	12 x 6	7.00 177.8	30.0 13.6
*4 x 2½	3.00 76.2	2.3 1.0	6 x 3	4.00 101.6	6.0 2.7	12 x 8	7.00 177.8	28.0 12.7
*4 x 76.1mm	3.00 76.2	3.2 1.5	*6 x 4	4.00 101.6	5.9 2.7	12 x 10	7.00 177.8	33.0 15.0
4 x 3	3.00 76.2	2.6 1.2	*6 x 139.7mm	4.00 101.6	6.3 2.9			

Note: Sizes marked with an asterisk (\*) are only available in Figure 250 Cast.  
Sizes without an asterisk are only available in Figure 350 Fabricated.

## ADA CAP® Patented



Pipe Size Inches	Outlet NPT* Inches	Nominal Dimensions				Net Wt. Lbs. Kg.
		O.D. Inches mm	Takeout A Inches mm	Center to End B Inches mm	Center to End C Inches mm	
1½	½	1.900 48.3	1.25 31.8	1.75 44.5	1.89 48.0	0.77 0.3
	¾		1.25 31.8	1.75 44.5	1.89 48.0	0.77 0.3
	1		1.37 34.8	2.00 50.8	2.02 51.3	0.88 0.4
2	½	2.375 60.3	1.25 31.8	1.75 44.5	1.89 48.0	0.92 0.4
	¾		1.25 31.8	1.75 44.5	1.89 48.0	0.92 0.4
	1		1.37 34.8	2.00 50.8	2.02 51.3	1.06 0.5
2½	½	2.875 73.0	1.47 37.3	1.97 50.0	1.89 48.0	1.28 0.6
	¾		1.47 37.3	1.97 50.0	1.89 48.0	1.28 0.6
	1		1.37 34.8	2.00 50.8	2.02 51.3	1.50 0.7

\* ISO-7 threaded outlets are available upon request.

## Figures 391, 392, 393, 312 and 313

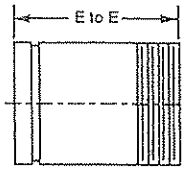


Figure 391

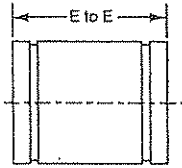


Figure 392

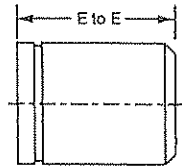


Figure 393

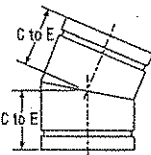


Figure 312

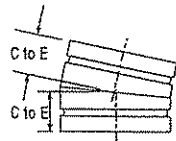


Figure 313

Nominal Size	Figures 391, 392 and 393 Adapter Nipples		Figure 312 22 1/2° Elbow		Figure 313 11 1/4° Elbow	
	E to E Inches <i>mm</i>	Appx. Wt. Lbs. <i>Kg.</i>	C to E Inches <i>mm</i>	Appx. Wt. Lbs. <i>Kg.</i>	C to E Inches <i>mm</i>	Appx. Wt. Lbs. <i>Kg.</i>
1 1/4"	4.00 101.6	0.8 0.4	1.75 44.5	0.4 0.2	1.38 35.1	0.4 0.2
1 1/2"	4.00 101.6	0.9 0.4	1.75 44.5	0.5 0.2	1.38 35.1	0.5 0.2
2"	4.00 101.6	1.2 0.5	1.88 47.8	0.6 0.3	1.38 35.1	0.6 0.3
2 1/2"	4.00 101.6	1.9 0.9	2.00 50.8	0.7 0.3	1.50 38.1	1.1 0.5
3"	4.00 101.6	2.5 1.1	2.25 57.2	1.4 0.6	1.50 38.1	1.2 0.5
4"	6.00 152.4	5.5 2.5	2.63 66.8	2.4 1.1	1.75 44.5	2.2 1.0
5"	6.00 152.4	7.4 3.4	2.88 73.2	4.1 1.9	2.00 50.8	3.3 1.5
6"	6.00 152.4	9.5 4.3	3.13 79.5	5.6 2.5	2.00 50.8	4.6 2.1
8"	6.00 152.4	14.2 6.4	3.88 98.6	11.1 5.0	2.00 50.8	8.7 3.9
10"	8.00 203.2	27.0 12.2	4.38 11.3	14.0 6.4	2.13 54.1	9.1 4.1
12"	8.00 203.2	33.0 15.0	4.88 124.0	22.0 10.0	2.25 57.2	16.7 7.6

## Figures 327 and 341

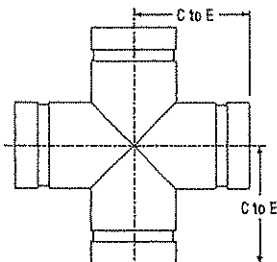


Figure 327

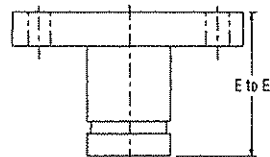


Figure 341

Nominal Size	Figure 327 Cross		Figure 341 150 lbs. Flange Adapter	
	C to E Inches <i>mm</i>	Appx. Wt. Lbs. <i>kg.</i>	E to E Inches <i>mm</i>	Appx. Wt. Lbs. <i>kg.</i>
1 1/4"	2.75 69.6	2.0 0.9	4.00 101.6	2.8 1.3
1 1/2"	2.75 69.9	2.2 2.0	4.00 101.6	3.2 1.5
2"	3.25 82.6	2.7 1.2	4.0 101.6	5.2 2.4
2 1/2"	3.75 95.3	5.0 2.3	4.00 101.6	8.0 3.6
3"	4.25 108.0	7.1 3.2	4.00 101.6	10.2 4.6
4"	5.00 127.0	11.9 5.4	6.00 152.4	17.2 7.8
5"	5.50 139.7	17.1 7.8	6.00 152.4	21.4 9.7
6"	6.50 165.1	27.5 12.5	6.00 152.4	26.0 11.8
8"	7.75 196.9	47.0 21.3	6.00 152.4	38.4 17.4
10"	9.00 228.6	68.0 30.8	8.00 203.2	65.0 29.5
12"	10.00 254.0	107.0 48.5	8.00 203.2	91.0 41.3



**STENNIS RIVERINE & COMBATANT TRAINING**  
**FACILITY**  
**STENNIS SPACE CENTER**  
**STENNIS, MS 39529**

**FIRE PROTECTION/ SPRINKLER SYSTEMS**  
**OPERATIONS BUILDING 2440/2441**  
**BOAT STORAGE BUILDING 2442**

## **SECTION 4**

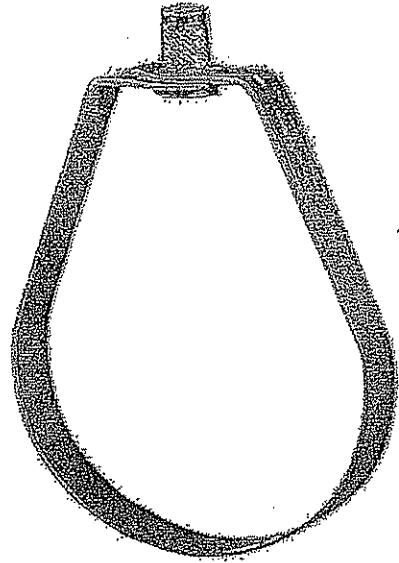
# **PIPE HANGERS & SUPPORTS**

**SIMPLEXGRINNELL**  
**5800 JEFFERSON HWY., SUITE A**  
**HARAHAN, LA 70123**  
**PHONE: 504-736-0104**  
**FAX: 504-736-9292**

Adjustable Swivel Ring, Tapped Per NFPA Standards

Fig. 69

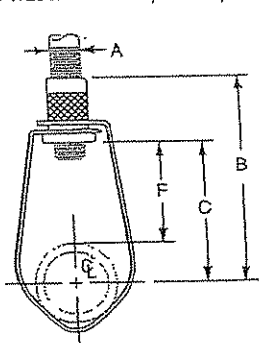
**Size Range:** 1/2" through 8"  
**Material:** Carbon steel  
**Finish:** Galvanized  
**Service:** Recommended for suspension of non-insulated stationary pipe line.  
**Maximum Temperature:** 650° F  
**Approvals:** Complies with Federal Specification A-A-1192A (Type 10) WW-H-171-E (Type 10) and MSS-SP-69 (Type 10).  
 UL, ULC Listed and FM Approved (Sizes 3/4" - 8").



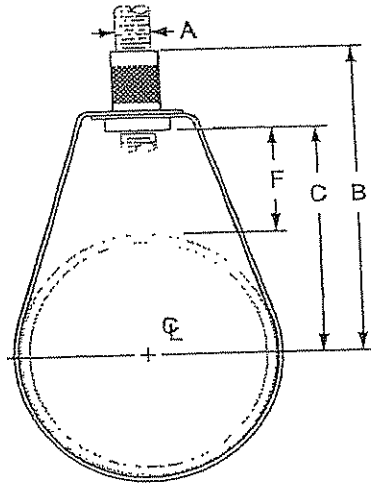
- Features:**
- Threads are countersunk so that they cannot become burred or damaged.
  - Knurled swivel nut provides vertical adjustment after piping is in place.
  - Captured swivel nut in the 1/2" through 3" sizes.

**Ordering:** Specify size, figure number and name.

**Note:** The acceptability of galvanized coatings at temperatures above 450°F is at the discretion of the end user.  
 Metric nut available upon request.



1/2" through 1" Pipe



1 1/4" through 8" Pipe

Fig. 69: Loads (lbs) • Weight (lbs) • Dimensions (in)

Pipe Size	Max Load	Weight	Rod Size A	B	C	F
1/2	300	0.10	3/8	2 7/8	2	1 9/16
3/4		0.10		2 3/4	1 7/8	1 5/16
1		0.10		2 5/8	1 11/16	1
1 1/4		0.10		2 3/4	1 7/8	7/8
1 1/2		0.10		3 1/4	2 3/8	1 1/8
2		0.11		4	2 3/4	1 5/16
2 1/2	525	0.20	1/2	3 13/16	2 15/16	1 3/16
3		0.20		4 11/16	3 13/16	1 9/16
4		0.30		5 5/16	4 3/8	1 9/16
5	1,000	0.54	1/2	6 11/16	5 9/16	2 1/4
6		0.65		8	7	2 11/16
8		1.00				

Note: Reflects changes in rod diameter from previously published data per recent revisions in MSS-SP-58 & 69

**Universal C-type Clamp (Standard Throat)**
**Fig. 92**
**Size Range:** 3/8 and 1/2"

**Material:** Ductile iron, hardened steel cup point set screw and locknut.

**Finish:** Plain or Galvanized

**Service:** Recommended for use under roof installations with bar joist type construction, or for attachment to the top or bottom flange of structural shapes where the vertical hanger rod is required to be offset from the edge of the flange and where the thickness of joist or flange does not exceed 3/4".

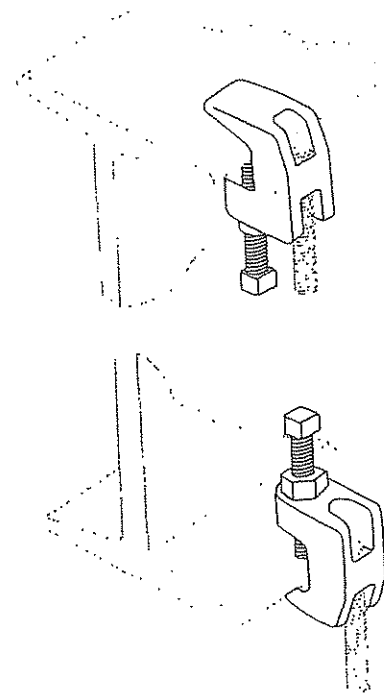
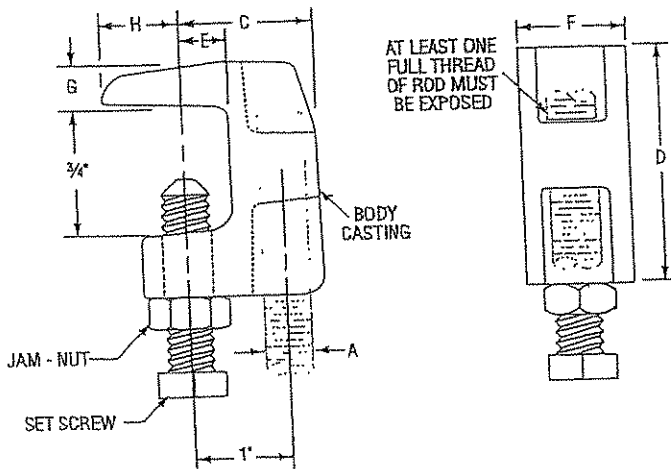
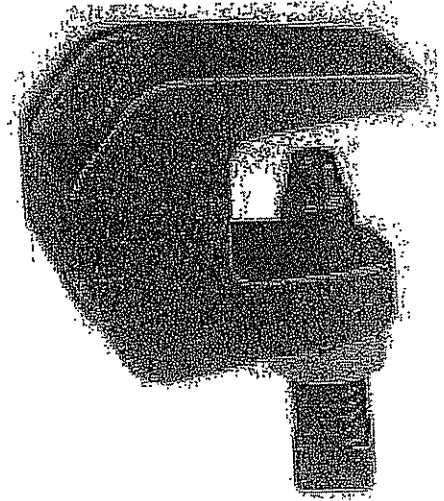
**Approvals:** Complies with Federal Specification A-A-1192A (Type 19 & 23) WW-H-171-E (Type 23) and MSS-SP-69 (Type 19 & 23).  
 UL, ULC Listed and FM Approved.

**How to size:** Size of clamp is determined by size of rod to be used.

**Installation:** Follow recommended set screw torque values per MSS-SP-69  
 (See table on page PH-212)

**Features:**

- They may be attached to horizontal flanges of structural members in either the top beam or bottom beam positions.
- Secured in place by a cup-pointed Set Screw tightened against the flange.  
A Jam Nut is provided for tightening the Set Screw against the Body Casting.
- Thru tapping of the body casting permits extended adjustment of the threaded rod.
- Can be used with Fig 89X retaining clip for seismic applications.

**Ordering:** Specify rod size, figure number, name of clamp and finish.

**Fig. 92: Load (lbs) • Weight (lbs) • Dimensions (in)**

Rod Size A	Set Screw Size	Max Loads ■		Weight	C	D	E	F	G	H
		Top	Bottom							
3/8	3/8	500	250	0.34	1 5/16	1 9/16	9/16	1 3/16	3/8	1/2
1/2	1/2	950	760	0.63	1 3/8	1 13/16	1/2	1 1/16	7/16	23/32

■ Maximum temperature of 450° F

**Beam Clamps**

Fig. 142

Coach Screw Rods  
Machine Threaded on Opposite End

Size Range: 3/8" and 1/2"

Material: Carbon steel

Finish: Plain

Ordering: Specify rod size, figure number, name and rod length.

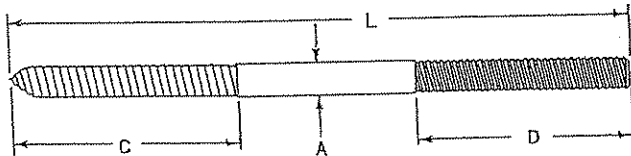


Fig. 142: Standard Thread Lengths(in) • Loads (lbs)

Rod Size A	Standard Length - L	Coach Screw Thread Length - C	Standard Rod Thread Length - D	Max Load
3/8	3 1/2	2	3/4	390
	B		2 1/2	
1/2	3 1/2	27/16	3/4	640
	B		2 1/2	

Fig. 146

Continuous Threaded Rod

Size Range: 1/4" through 1 1/2" Stocked in six, ten, and twelve foot lengths. Other even foot lengths can be furnished to order.

Material: Carbon steel; rod threaded complete length.

Finish: Plain or galvanized.

Maximum Temperature: 650° F.

Ordering: Specify rod diameter and length, figure number, name and finish.

Note: The acceptability of galvanized coatings at temperatures above 450° F is at the discretion of the end user.

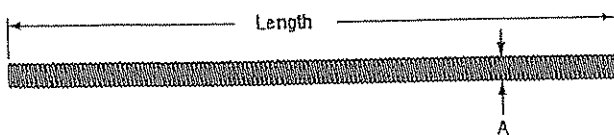


Fig. 146: Loads (lbs) • Weights (lbs) Dimensions (in)

Rod Size A	Threads per Inch	Max Load	Weight per Ft.
		650° F	
1/4	20	240	0.12
3/8	16	730	0.30
1/2	13	1,350	0.53
5/8	11	2,160	0.84
3/4	10	3,230	1.20
7/8	9	4,480	1.70
1	8	5,900	2.30
1 1/4	7	9,500	3.60
1 1/2	6	13,800	5.10

Note: Other rod sizes available upon request.  
Class 2 fit is available upon request.

Fig. 89

## Retaining Clip

**Size Range:** 3/8" through 1/2"

**Material:** Carbon steel

**Finish:**  Plain or  Galvanized

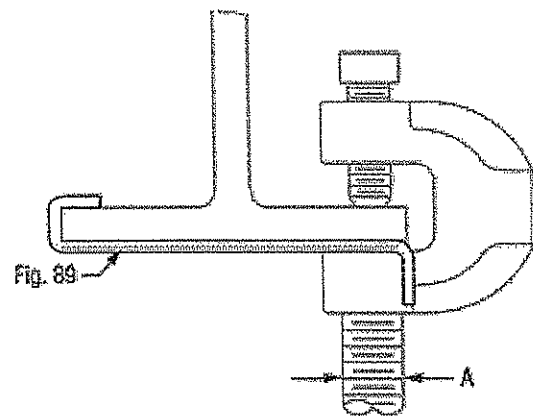
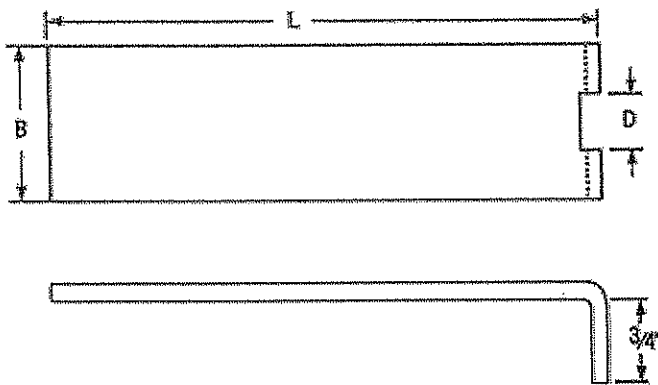
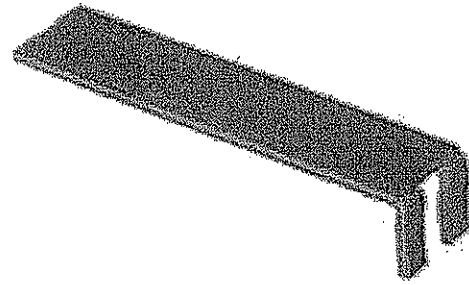
**Service:** For use with Figs. 86, 87, 88 & 95 in seismic applications.

**How to size:** Specify length of retaining strap based on beam size.

**Installation:** Length of strap should be adequate to allow at least 1" of strap to be bent over the beam side of the flange opposite the side the beam clamp is mounted on.

**Ordering:** Specify rod size, Figure number, name, length of retaining clip and finish (Add 2" to flange width of beam to arrive at proper length of retaining clip).

If required length is not standard, order next longer standard.



Rod Size A	B	D	Weights				Length L
			4 1/2	8	10	14	
3/8	1	7/16	0.17	0.28	0.35	0.53	4 1/2, 8, 10, 14
1/2	1 1/4	15/32	0.22	0.37	0.46	0.83	
5/8	1 3/8	1 1/16	0.25	0.43	0.51	0.73	
3/4							

# SAMMYS®

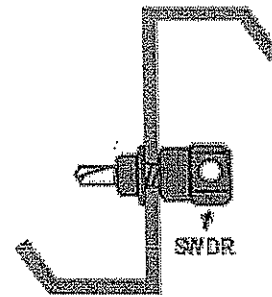
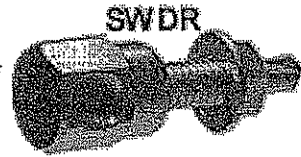
Ask for SAMMYS in the YELLOW Box!

Home | Up | Seismicreesample | Seismic | GST - Wood Sammy | SWG - Wood SW | DST - Steel Sammy | SWDR - Steel SW | CST - Concrete Sammy | SWC - Concrete SW | SS Wood | SS Steel | Sheetrock | Hurricane | Ceiling Screws | Pole Tool | Sammy Assortment | Sammy Saddle | Sammy Swivel Head | Dektite | Install Kit









American Made


## Steel Sidewinder - Self drilling & self-taping into steel







Steel • 1/4" Rod • Horizontal Mount									
Use #14SW Nut Driver (Item #101)									
Item No	Part #	Model	Screw Description	Rod Size	Shank Diameter	Minimum Thickness	Max Thickness	Actual Shear Pullout	
2003	8047957	SWD 100	1/4-14 x 1	1/4-20	1/4	.066" - 16 ga.	1/4"	1477# / 16 ga.	#14SW Item #101
206	8049957	SWDR 100	1/4-20	1/4-20	1/4	.036 - 20 ga.	1/4"	1900# / 20 ga.	PN 8114910

Steel • 3/8" Rod • Horizontal Mount												
Use #14SW Nut Driver (Item #101)												
Item No	Part #	Model	Rod Size	Description	UL Test Load (lb)	UL Minimum Steel Thickness	FM Test Load (lb)	FM Minimum Steel Thickness	UL/FM Pipe Size inches	Minimum Thickness	Max. Thick.	Actua Shear/Pul

						inches		inches					
39	8050957	SWD 10	3/8-16	1/4-14x1						.066"-16ga	1/4	1477# / 16	
40	8051957	SWD 15	3/8-16	1/4-14x1 1/2	Note: Screw diameter/design/performance for SWD 10 (1" length) through DST 30 (3" length) are constant. Only the lengths vary.								
41	8052957	SWD 20	3/8-16	1/4-14x2									
42	8053957	SWD 516	3/8-16	5/16-18x1 1/4									
 	43	8055957	SWDR 1"	3/8-16	1/4-20x1	1500	.037	1475	.060	4/4	.036"-20ga	1/4"	1900# / 21
 	44	8056957	SWDR 516	3/8-16	5/16-18x1 1/4	1500	.037	1475	.060	4/4	.036"-20ga	1/4"	2480# / 21
 	46	8054957	SWDR 1 1/2"	3/8-16	1/4-20x1 1/2	1500	.037	1475	.060	4/4	.036"-20ga	1/2"	2375# /
	45	8057957	SWT 15	3/8-16	12-24x1 1/2						.25"-1/4"	1/2"	
1 When installing DSTR or SWDR add retainer nut and torque to 20 foot lbs. for maximum pull out in steel.													

Click on  symbol to link direct to UL Online Certification

Click on  symbol to link direct to FM Global Loss Prevention Data Sheet 1-2.

Legend	
	Factory Mutual Approved
	UL-listed.
	Box quantity 25. Standard box quantity 125, except where so indicated.

[Factory Mutual and UL listed approvals - pdf](#)

[Link to DOWNLOADS including: Product Catalog, engineering \(CAD\) drawings, list of FM approvals, ICC Evaluation Service Dade Online Certification and UL test reports.](#)

[Download Steel Sammy Sell Sheet.pdf](#)

## Installation Instructions

DST, DSTR, TEK 50, SWD, SWDR, SWT
See Figures 1 through 4 (vertical) and 11 through 14 (horizontal) of detailed installation instructions for illustrations.
<ul style="list-style-type: none"> <li>DST self-drills &amp; self-taps into steel up to 3/16" thick.</li> <li>DSTR self-drills &amp; self-taps into steel up to 3/16" thick and accepts retainer nut.</li> <li>TEK 50 - Self-drills &amp; self-taps into steel up to 1/2" thick.</li> <li>SWD self-drills &amp; self-taps through 3/16" steel.</li> <li>SWDR self-drills &amp; self-taps through 3/16" steel and accepts retainer nut.</li> <li>SWT self-drills &amp; self-taps through 1/2" steel.</li> </ul>

Step 1: Insert the appropriate nut driver into a 3/8" or 1/2" portable drill:

- a. use #14 Nut Driver for DST, DSTR, TEK 50;
- b. use #14SW Nut Driver for SWD, SWDR, SWT.

Step 2: Insert the screw into the nut driver. Now you are ready to install the screw.

Step 3: Position drill and begin installation:

- a. for installing DST, TEK 50, DSTR\*, the drill should be in a vertical position;
- b. for installing SWD, SWDR\*, SWT, the drill should be in a horizontal position at a right angle to the structural member.

Step 4: When the nut driver spins freely on the cap of the screw installation is complete.

Step 5: Screw is now ready to receive 1/4", 3/8", 1/2" or metric all-thread rod or bolt stock.

Warranty compliance requires that appropriate nut drivers be used for all installations.

---

[Download CAD Drawings](#)

[▶ Installation Instructions](#)

[▶ Safety Information](#)

[▶ Performance Data](#)

---

[Home](#) | [Seismicfreesample](#) | [Seismic](#) | [GST - Wood Sammy](#) | [SWG - Wood SW](#) | [DST - Steel Sammy](#) | [SWDR - Steel SW](#) | [CST - Concrete Sammy](#) | [SWC - Concrete SW](#) | [SS Wood](#) | [SS Steel](#) | [Sheetrock](#) | [Hurricane](#) | [Ceiling Screws](#) | [Pole Tool](#) | [Sammy Assortment](#) | [Sammy Saddle](#) | [Sammy Swivel Head](#) | [Dektite](#) | [Install Kit](#)

Information: submit a [request](#) or contact, [marketing@itwbuildex.com](mailto:marketing@itwbuildex.com)



Last modified: April 28, 2009

- An independent, non-profit content rating organization.

Copyright © 2002-2009: ITW Buildex. All trademarks or registered trademarks used are trademarks of Sammy Super Screw®, ITW Buildex and Illinois Tool Works, Inc. [ITW Buildex Privacy Policy](#) ITW Buildex uses WebTrends Live to analyze traffic to this web site. WebTrends Live does not create individual profiles for visitors. Unlike some tracking services WebTrends Live does not have a database of individual profiles for each visitor. WebTrends Live only collects aggregate data. For more information about WebTrends Live privacy policy, [please click here](#).

Send mail to: [webmaster@itwbuildex.com](mailto:webmaster@itwbuildex.com) with questions or comments about the webpage.

## g. 800 - Adjustable Sway Brace Attachment to Steel

Size Range — 4" thru 18" beam width

Material — Carbon Steel

Function — Seismic brace attachment to steel.

Features — This product's design incorporates a concentric attachment point which is critical to the performance of structural seismic connections. NFPA 13 indicates the importance of **concentric** loading of connections and fasteners. Permits secure connection to steel where drilling and/or welding of brace connection could present structural issues.

Installation Instructions — The Fig. 800 is the structural attachment component of a longitudinal or lateral sway brace assembly. It is intended to be combined with a TOLCO transitional attachment, "bracing pipe" and a TOLCO "braced pipe" attachment to form a complete bracing assembly. NFPA 13 and/or OSHPD guidelines should be followed.

To Install — Place the Fig. 800 on the steel beam, tighten the cone point set bolts on flange until bolt heads break off. Tighten hex head bolts into clamp body until lock washers are fully flat. Attach other TOLCO transitional attachment fittings, Fig. 909, 910 or 980. Transitional fitting attachment can pivot for adjustment to proper brace angle.

Approvals — Underwriters Laboratories Listed in the USA (UL) and Canada (cUL). Approved by Factory Mutual Engineering (FM). Included in our Seismic Restraints Catalog approved by the State of California Office of Statewide Health Planning and Development (OSHPD). For additional load, spacing and placement information relating to OSHPD projects, please refer to the TOLCO Seismic Restraint Systems Guidelines.

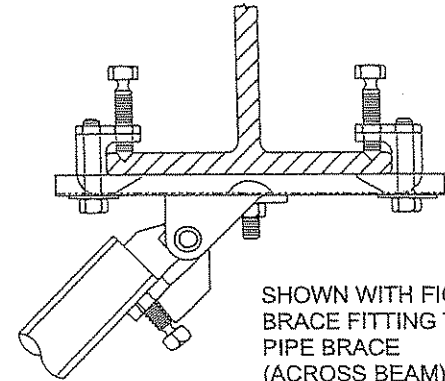
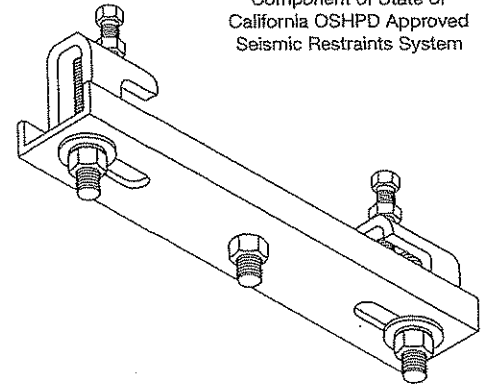
Finish — Plain

Note — Available in Electro-Galvanized and HDG finish.

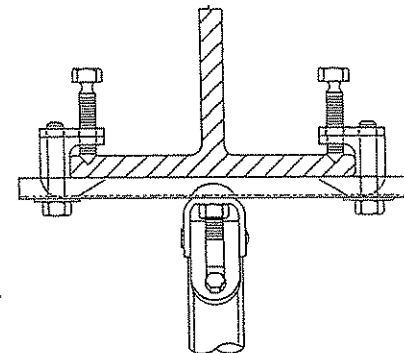
Order By — Figure number, type number and size number.



Component of State of California OSHPD Approved Seismic Restraints System



SHOWN WITH FIG. 980 BRACE FITTING TO PIPE BRACE (ACROSS BEAM)



SHOWN WITH FIG. 980 BRACE FITTING TO PIPE BRACE (ALONG BEAM)

### Dimensions • Weights

Size	Fits Beam Range (in.)	Max. Design Loads/Lbs. (cULus)		*Max. Design Loads/Lbs. (FM)	
		Along Beam	Across Beam	Along Beam	Across Beam
1	4 - 6	1265	2015	2800	2800
2	6 - 8	1265	2015	2800	2800
3	8 - 10	1265	2015	2800	2800
4	10 - 12	1265	2015	2800	2800
5	12 - 14	1265	2015	2800	2800
6	14 - 16	1265	2015	2800	2800
7	16 - 18	1265	2015	2800	2800

### Dimensions • Weights

Type	Flange Thickness Max. (in.)	Max. Design Loads/Lbs. (cULus)		*Max. Design Loads/Lbs. (FM)	
		Along Beam	Across Beam	Along Beam	Across Beam
1	3/4	1265	2015	2800	2800
2	1 1/4	1265	2015	2800	2800

\* Load shown is allowable with brace installed, between 30° - 90°. No reduction of load based on brace angle is required.

TOLCO® brand bracing components are designed to be compatible **ONLY** with other TOLCO® brand bracing components, resulting in a Listed seismic bracing assembly. **DISCLAIMER** — NIBCO does **NOT** warrant against the failure of TOLCO® brand bracing components, in the instance that such TOLCO® brand bracing components are used in combination with products, parts or systems which are not manufactured or sold under the TOLCO® brand. NIBCO shall **NOT** be liable under any circumstance for any direct or indirect, incidental or consequential damages of any kind, including but not limited to loss of business or profit, where non-TOLCO brand bracing components have been, or are used.

## Fig. 980 - Universal Swivel Sway Brace Attachment

**Size Range** — One size fits bracing pipe 1" thru 2", TOLCO 12 gauge channel, and all structural steel up to 1/4" thick.

**Material** — Carbon Steel

**Function** — Multi-functional attachment to structure or braced pipe fitting.

**Features** — This product's design incorporates a **concentric** attachment opening which is critical to the performance of structural seismic connections. NFPA 13 (2002) Figure 9.3.5.9.1 indicates clearly that fastener table load values are based only on concentric loading. Mounts to any surface angle. Break off bolt head assures verification of proper installation.

**Installation** — The Fig.980 is the structural or transitional attachment component of a longitudinal or lateral sway brace assembly. It is intended to be combined with the "bracing pipe" and TOLCO "braced pipe" attachment, Fig. 1000, 1001, 2002, 4L, 4A or 4B to form a complete bracing assembly. NFPA 13 and/or OSHPD guidelines should be followed.

**To Install** — Place the Fig. 980 onto the "bracing pipe". Tighten the set bolt until set bolt head breaks off. Attachment can pivot for adjustment to proper brace angle.

**Approvals** — Underwriters Laboratories Listed in the USA (UL) and Canada (cUL). Approved by Factory Mutual Engineering (FM). Included in our Seismic Restraints Catalog approved by the State of California Office of Statewide Health Planning and Development (OSHPD). For additional load, spacing and placement information relating to OSHPD projects, please refer to the TOLCO Seismic Restraint Systems Guidelines.

**Note** — The Fig. 980 Swivel Attachment and the Fig. 1001, Fig. 1000, Fig. 2001 or Fig. 4A Pipe Clamp make up a sway brace system of UL Listed attachments and bracing materials which satisfies the requirements of Underwriters' Laboratories and the National Fire Protection Association (NFPA)

**Finish** — Plain

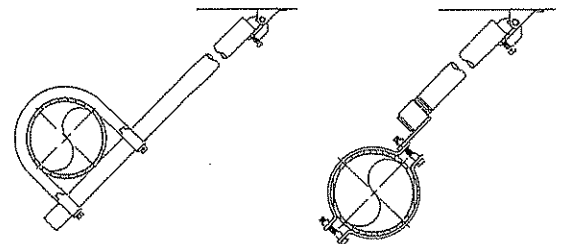
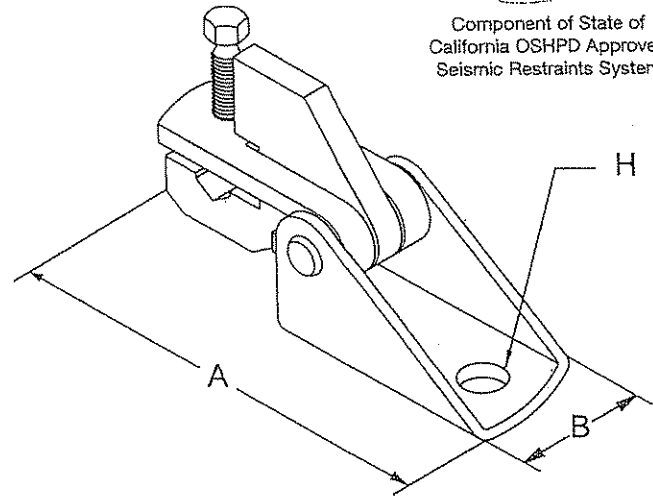
**Note** — Available in Electro-Galvanized finish.

**Order By** — Figure number and finish.

**PATENT #6,273,372**



Component of State of California OSHPD Approved Seismic Restraints System



Lateral Brace

### Dimensions • Weights

A	B	H*	Max. Design Load Lbs. (cULus)	**Max. Design Load Lbs. (FM)	Approx. Wt./100
5/4	1 7/8	17/32	2765	2800	132

\* Available with hole sizes to accommodate up to 3/4" fastener. Consult factory.

\*\* Load shown is allowable with brace installed, between 30° - 90°. No reduction of load based on brace angle is required.

TOLCO® brand bracing components are designed to be compatible **ONLY** with other TOLCO® brand bracing components, resulting in a Listed seismic bracing assembly. **DISCLAIMER** — NIBCO does **NOT** warrant against the failure of TOLCO® brand bracing components, in the instance that such TOLCO® brand bracing components are used in combination with products, parts or systems which are not manufactured or sold under the TOLCO® brand. NIBCO shall **NOT** be liable under any circumstance for any direct or indirect, incidental or consequential damages of any kind, including but not limited to loss of business or profit, where non-TOLCO brand bracing components have been, or are used.

## Fig. 1000 - "Fast Clamp" Sway Brace Attachment

Component of State of California OSHPD Approved Seismic Restraints System

**Size Range** — Pipe size to be braced: 1" thru 6" Schedule 10 thru 40 IPS.\* Pipe size used for bracing: 1" and 1 1/4" Schedule 40 IPS.

\* Additionally (UL) approved for use to brace Schedule 7 sprinkler pipe up to 4" (maximum horizontal design load 655 lbs.) Torque requirement 6 — 8 ft. lbs.

**Material** — Carbon Steel

**Function** — For bracing pipe against sway and seismic disturbance. The pipe attachment component of a sway brace system: Fig. 1000 is used in conjunction with a TOLCO Fig. 900 Series Fitting and joined together with bracing pipe per NFPA 13\* or TOLCO OSHPD Approved Seismic Manual, forming a complete sway brace assembly.

**Features** — Field adjustable, making critical pre-engineering of bracing pipe unnecessary. Unique design requires no threading of bracing pipe. Can be used as a component of a 4-way riser brace. Can be used as longitudinal brace with Fig. 907. Comes assembled and individually packaged with illustrated installation instructions — sizes are clearly marked. Steel leaf spring insert provided to assure installer and inspector necessary minimum torque has been achieved.

**Installation** — The Fig. 1000 is the "braced pipe" attachment component of a lateral sway brace assembly. It is intended to be combined with the "bracing pipe" and TOLCO structural attachment component, Fig. 980, 910 or 909 to form a complete bracing assembly. Follow NFPA 13 and/or OSHPD guidelines.

**To Install** — Place the Fig. 1000 over the pipe to be braced, insert bracing pipe through opening leaving a minimum of 1" extension. Brace pipe can be installed on top or bottom of pipe to be braced. Tighten hex nuts until leaf spring is flat. It is recommended that the brace angle be adjusted before hex nuts are fully tightened.

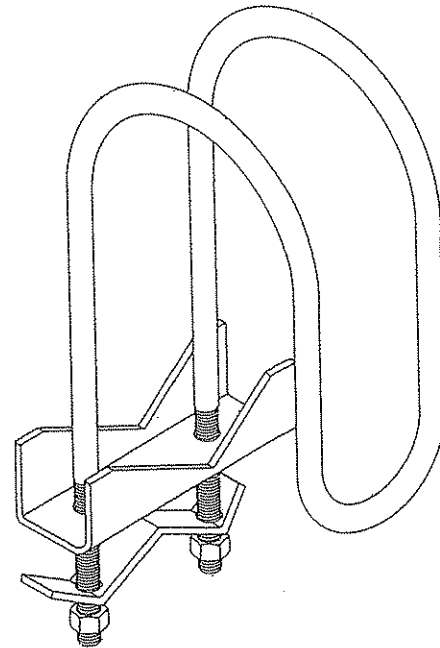
**Approvals** — Underwriters Laboratories Listed in the USA (UL) and Canada (cUL). Approved by Factory Mutual Engineering (FM). Included in our Seismic Restraints Catalog approved by the State of California Office of Statewide Health Planning and Development (OSHPD). For additional load, spacing and placement information relating to OSHPD projects, please refer to the TOLCO Seismic Restraint Systems Guidelines.

**Application Note** — Position Fast Clamp and tighten two hex nuts until leaf spring flattens. A minimum of 1" pipe extension beyond the Fig. 1000 is recommended.

**Finish** — Plain

**Note** — Available in Electro-Galvanized and HDG finish or Stainless Steel materials.

**Order By** — Order first by pipe size to be braced, followed by pipe size used for bracing, figure number and finish.

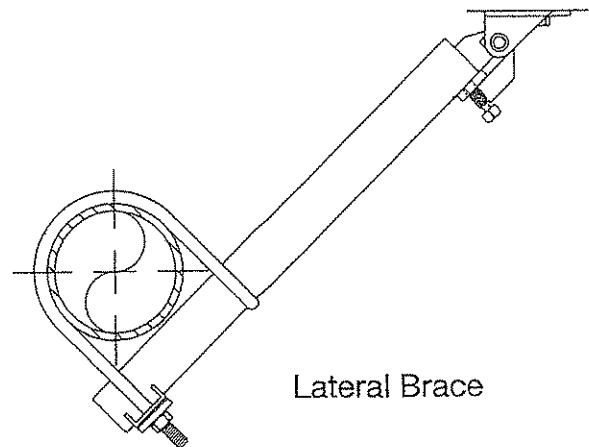


cUL US LISTED



Maximum Design Load  
1" thru 4" pipe size — 2015 lbs.  
6" size — 1265 lbs.

FM Approved Design Loads\*  
1" - 2 1/2" - 600 lbs.  
3" - 4" - 700 lbs.



Lateral Brace

TOLCO® brand bracing components are designed to be compatible **ONLY** with other TOLCO® brand bracing components, resulting in a Listed seismic bracing assembly. **DISCLAIMER** — NIBCO does **NOT** warrant against the failure of TOLCO® brand bracing components, in the instance that such TOLCO® brand bracing components are used in combination with products, parts or systems which are not manufactured or sold under the TOLCO® brand. NIBCO shall **NOT** be liable under any circumstance for any direct or indirect, incidental or consequential damages of any kind, including but not limited to loss of business or profit, where non-TOLCO brand bracing components have been, or are used.

## g. 825A - Bar Joist Sway Brace Attachment



**Size Range** — One size accommodates all TOLCO Fig. 900 Series sway brace attachments. Maximum Horizontal Design Load 1265 lbs.

**Material** — Carbon Steel

**Function** — To attach sway bracing to steel open web structural members.

**Features** — This product's design incorporates a **concentric** attachment point which is critical to the performance of structural seismic connections. NFPA 13 indicates the importance of **concentric** loading of connections and fasteners. Permits secure non-friction connection without drilling or welding. Unique design reinforces point of connection to joist. Break off head bolt design assures verification of proper installation.

**Approvals** — Underwriter's Laboratories Listed in the USA (**UL**) and Canada (**cUL**). For additional load, spacing and placement information relating to OSHPD projects, please refer to the TOLCO Seismic Restraint Systems Guidelines.

**Installation Instructions** — The Fig. 825A is the structural attachment component of a longitudinal or lateral sway brace assembly. It is intended to be combined with a TOLCO transitional attachment, "bracing pipe" and a TOLCO "braced pipe" attachment to form a complete bracing assembly. NFPA 13 and/or OSHPD guidelines should be followed.

**To Install** — Place the Fig. 825A on the steel beam, tighten the cone joint set bolts until bolt heads break off. Attach other TOLCO transitional attachment fitting, Fig. 909, 910 or 980. Transitional fitting attachment can pivot for adjustment to proper brace angle.

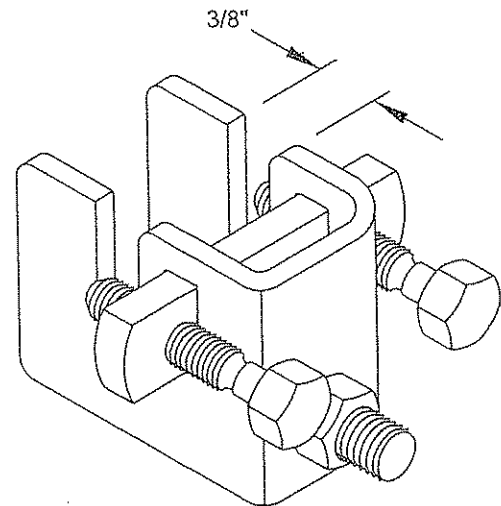
**Important Structural Note:**

The TOLCO Fig. 825A has significant UL established design loads, however, structural issues related to the steel joist member require restricted location installation for all bracing. Steel Joist Manufacturers require that all earthquake bracing connections be within 6" of the cord panel point. Installation of the Fig. 825A is not restricted to the two outer third sections of the joist. For greater design loads, refer to TOLCO Fig. 825.

**Finish** — Plain

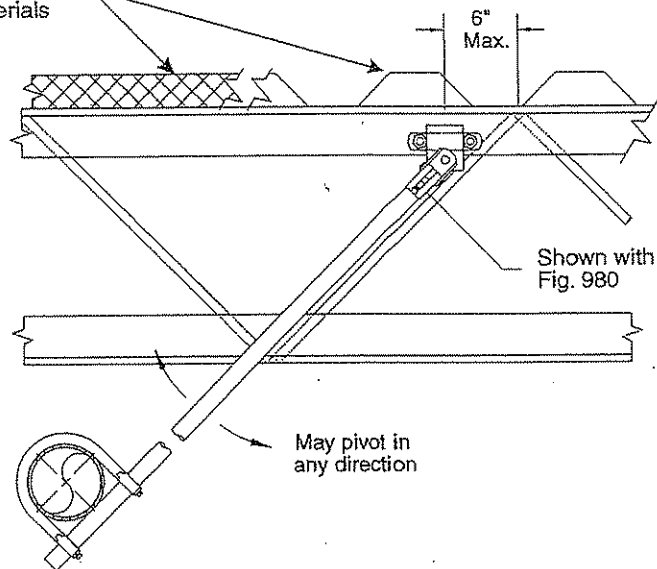
**Order By** — Figure number and finish

Patent #6,098,942



Maximum Design Load 1265 Lbs.

Bar joist shown attached to various roof materials



TOLCO® brand bracing components are designed to be compatible **ONLY** with other TOLCO® brand bracing components, resulting in a Listed seismic bracing assembly. **DISCLAIMER** — NIBCO does **NOT** warrant against the failure of TOLCO® brand bracing components, in the instance that such TOLCO® brand bracing components are used in combination with products, parts or systems which are not manufactured or sold under the TOLCO® brand. NIBCO shall **NOT** be liable under any circumstance for any direct or indirect, incidental or consequential damages of any kind, including but not limited to loss of business or profit, where non-TOLCO brand bracing components have been, or are used.



# Fig. 4L Longitudinal "In-Line" Sway Brace Attachment



**Size Range** — 2½" through 8" IPS.

**Material** — Carbon Steel

**Function** — For bracing pipe against sway and seismic disturbance.

**Approvals** — Underwriter's Laboratories Listed in the USA (UL) and Canada (cUL) 2½" - 8". Approved by Factory Mutual Engineering (FM), 2½" - 8" pipe.

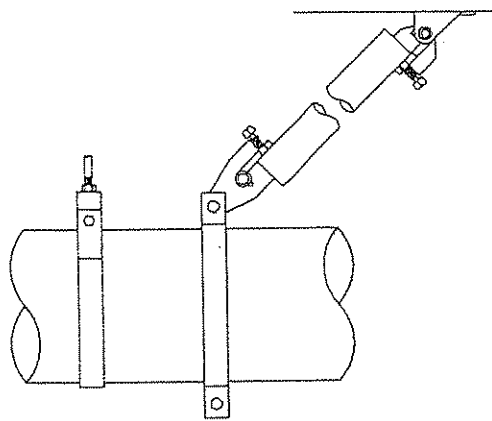
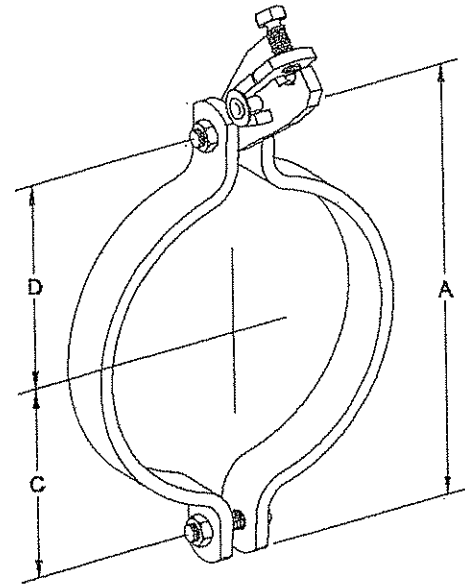
**Installation Instructions** — The Fig. 4L is the "braced pipe" attachment component of a longitudinal sway brace assembly. It is intended to be combined with the "bracing pipe" and TOLCO structural attachment component to form a complete bracing assembly. NFPA 13 and/or OSHPD guidelines should be followed.

**To Install** — Place the Fig. 4L over the pipe to be braced and tighten bolts. Then engage "bracing pipe" into jaw opening and tighten set bolt until hex head snaps off. Jaw attachment can pivot for adjustment to proper brace angle.

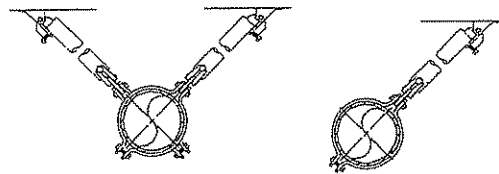
**Finish** — Plain

**Note** — Available in Electro-Galvanized and HDG finish.

**Order By** — Figure number, pipe size and finish.



Longitudinal Brace



4-Way Riser Brace  
(Plan view)

### Dimensions • Weights

Sizes	A	C	D	Bolt Size	Max. Rec. Load Lbs. (cULus)	*Max Rec. Load Lbs. (FM)	Approx. Wt./100
2½	6⅞	2½	2¼	1/2	2015	3000	253
3	7	2¾	3⅞	1/2	2015	1550	268
4	8½	3⅞	3⅞	1/2	2015	1550	348
5	9¾	3⅞	4⅞	1/2	2015	1450	380
6	11½	5	5⅞	1/2	2015	1450	640
8	13¼	6⅞	6⅞	1/2	2015	1450	728

\* Load shown is allowable with brace installed, between 30° - 90°. No reduction of load based on brace angle is required.

FM approved when used with 1", 1¼", 1½" or 2" Sch. 40 brace pipe.

TOLCO® brand bracing components are designed to be compatible **ONLY** with other TOLCO® brand bracing components, resulting in a Listed seismic bracing assembly. **DISCLAIMER** — NIBCO does **NOT** warrant against the failure of TOLCO® brand bracing components, in the instance that such TOLCO® brand bracing components are used in combination with products, parts or systems which are not manufactured or sold under the TOLCO® brand. NIBCO shall **NOT** be liable under any circumstance for any direct or indirect, incidental or consequential damages of any kind, including but not limited to loss of business or profit, where non-TOLCO brand bracing components have been, or are used.

## Fig. 25 - Surge Restrainer



**Size Range** — One size fits 3/4" thru 2" pipe.

**Material** — Pre-Galvanized Steel

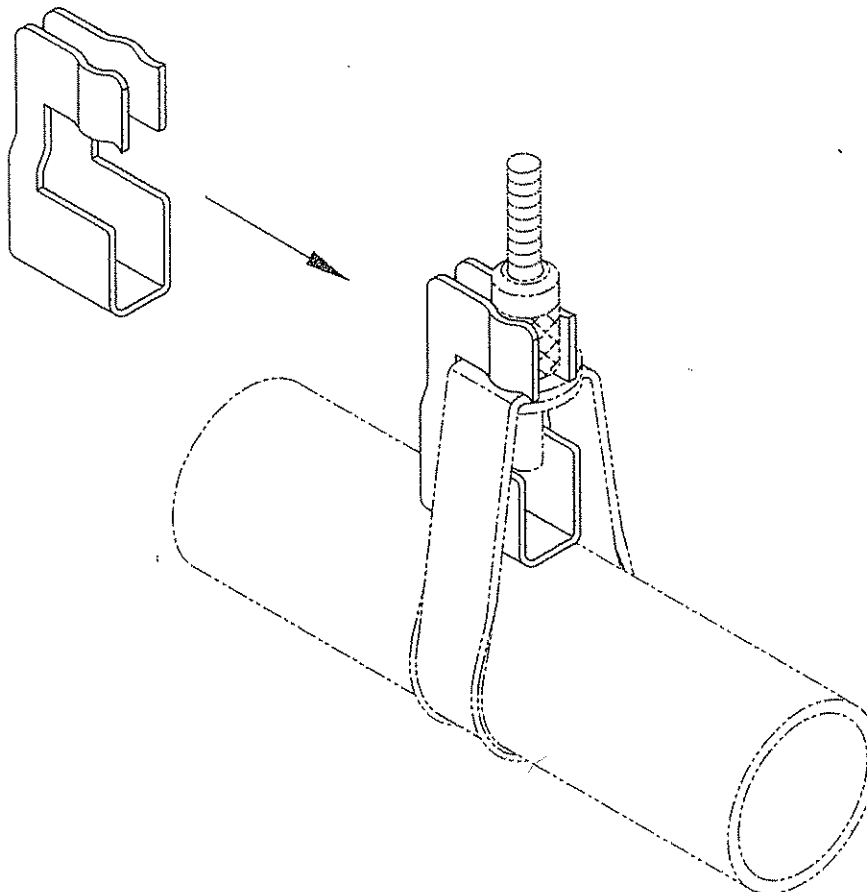
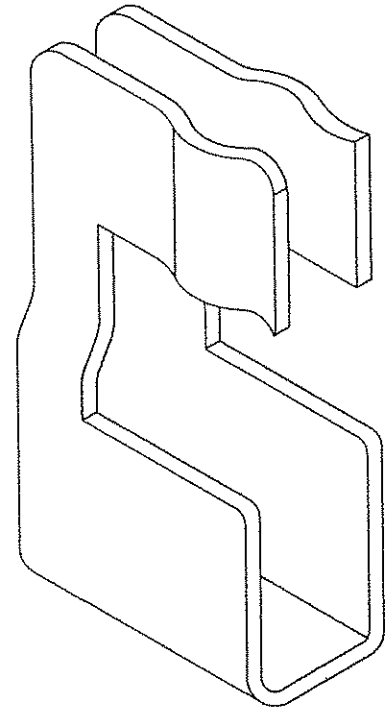
**Function** — Designed to be used in conjunction with TOLCO® Band Hangers to restrict the upward movement of piping as it occurs during sprinkler head activation or earthquake type activity. The surge restrainer is easily and efficiently installed by snapping into a locking position on the band hanger. This product is intended to satisfy the requirements as indicated in the National Fire Protection Association NFPA 13, 2007 edition, 9.2.3.4.4.1 and 9.2.3.4.4.4 Can be used to restrain either steel pipe or CPVC plastic Pipe.

**Approvals** — Underwriters' Laboratories Listed **only** when used with TOLCO band hangers Fig. 2, 2NFPA and 200, in the USA (**UL**) and Canada (**cUL**).

**Finish** — Pre-Galvanized

**Order By** — Figure number and TOLCO band hanger, size from 3/4" thru 2".

Patent #5,344,108



# Fig. 75 - Swivel Attachment



**Size Range** — 3/8" Rod Attachment

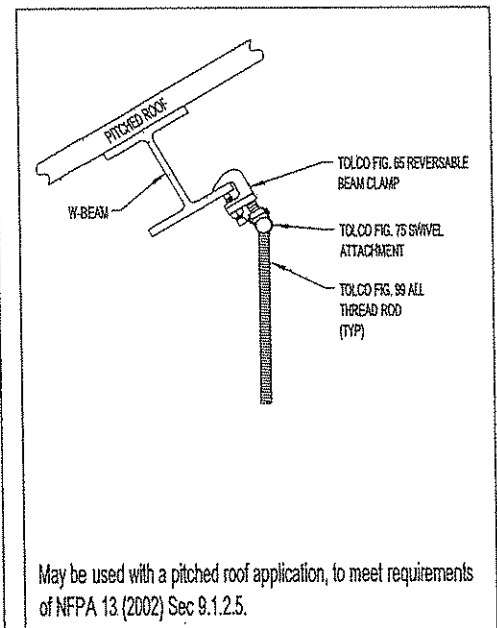
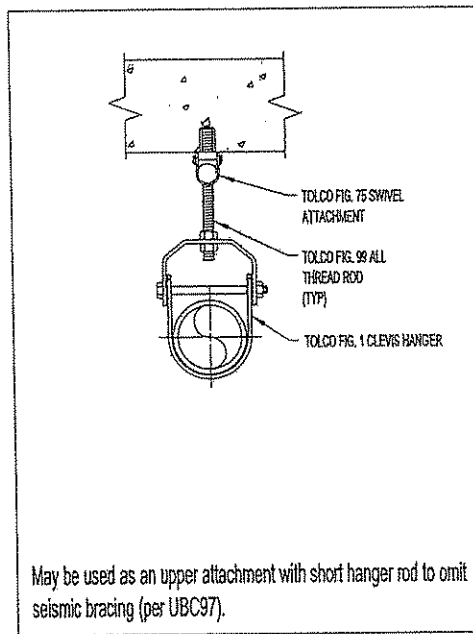
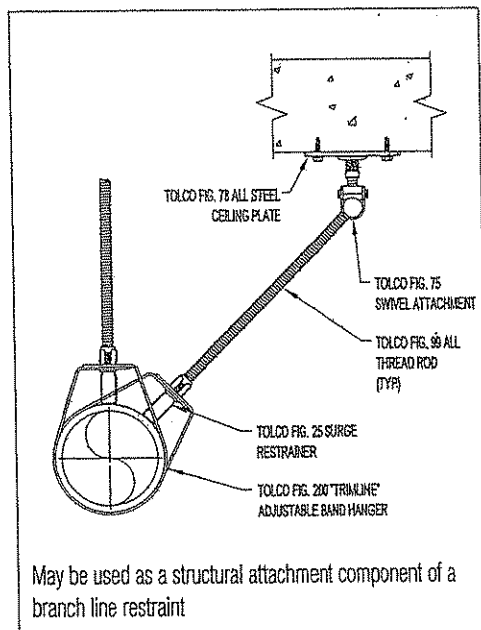
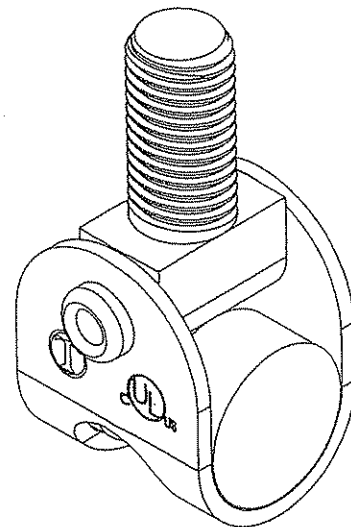
**Material** — Carbon Steel

**Function** — There are three recommended applications for this product: May be used as a Branch Line Restraint for structural attachment to anchor bolt, beam clamp, etc. May be used in a pitched or sloped roof application, to meet requirements of NFPA 13 (2002) Sec 9.1.2.5. May be used as an upper attachment with short hanger rod to omit seismic bracing (per UBC97).

**Approvals** — Underwriters' Laboratories Listed in the USA (UL) and Canada (cUL) to support up to 4" pipe. Meets requirements of Uniform Building Code (UBC) 1997 Table O, Section 3.B.

**Finish** — Electro-Galvanized

**Order By** — Figure number



## Fig. 909 - No-Thread Swivel Sway Brace Attachment



**Size Range** — 1" bracing pipe. For brace pipe sizes larger than 1", use TOLCO Fig. 980.

**Material** — Carbon Steel, hardened cone point engaging screw

**Function** — The structural component of a sway and seismic bracing system.

**Features** — This product's design incorporates a **concentric** attachment opening which is critical to the performance of structural seismic connections. NFPA 13 (2002) Figure 9.3.5.9.1 indicates clearly that fastener table load values are based only on concentric loading. No threading of the bracing pipe is required. Open design allows for easy inspection of pipe engagement.

**Application Note** — The Fig. 909 is used in conjunction with the TOLCO Fig. 1000, Fig. 1001, or Fig. 4 (A) pipe clamp, and joined together with bracing pipe. Sway brace assemblies are intended to be installed in accordance with NFPA 13 (or TOLCO State of California OSHPD Approved Seismic Restraint Manual) and the manufacturer's installation instructions. The required type, number and size of fasteners used for the structure attachment fitting shall be in accordance with NFPA 13 and/or OSHPD.

**Approvals** — Underwriters Laboratories Listed in the USA (UL) and Canada (cUL). Included in our Seismic Restraints Catalog approved by the State of California Office of Statewide Health Planning and Development (OSHPD). For additional load, spacing and placement information relating to OSHPD projects, please refer to the TOLCO Seismic Restraint Systems Guidelines.

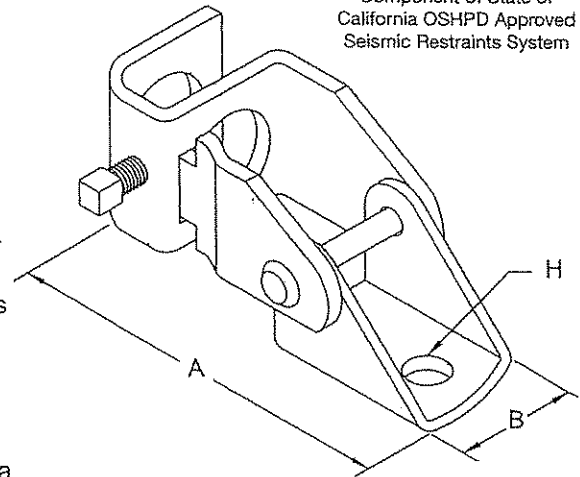
**Installation Instructions** — The Fig. 909 is the structural or transitional attachment component of a longitudinal or lateral sway brace assembly. It is intended to be combined with the "bracing pipe" and TOLCO "braced pipe" attachment, Fig. 1000, 1001, 4A, 4B or 4L to form a complete bracing assembly. NFPA 13 and/or OSHPD guidelines should be followed.

**To Install** — Place the Fig. 909 onto the bracing pipe. Tighten the set bolt until head bottoms out on surface. Attachment can pivot for adjustment to proper brace angle.

**Finish** — Plain

**Note** — Available in Electro-Galvanized and HDG finish.

**Order By** — Figure number, pipe size and finish.



Component of State of California OSHPD Approved Seismic Restraints System

### Dimensions • Weights

Pipe Size	A	B	Hole Size H*	Max. Design. Load Lbs.	Max. Design Load Lbs. w/Washer	Approx. Wt./100
1	6	1 5/8	17/32	2015	2765	91

\* Available with hole sizes to accommodate up to 3/4" fastener. Consult Factory.

TOLCO® brand bracing components are designed to be compatible **ONLY** with other TOLCO® brand bracing components, resulting in a Listed seismic bracing assembly. **DISCLAIMER** — NIBCO does **NOT** warrant against the failure of TOLCO® brand bracing components, in the instance that such TOLCO® brand bracing components are used in combination with products, parts or systems which are not manufactured or sold under the TOLCO® brand. NIBCO shall **NOT** be liable under any circumstance for any direct or indirect, incidental or consequential damages of any kind, including but not limited to loss of business or profit, where non-TOLCO brand bracing components have been, or are used.

## Fig. 907 - 4-Way Longitudinal Sway Brace Attachment



**Size Range** — 1" x 1", 1" x 1¼" and 1¼" x 1¼" bracing pipe.

**Material** — Carbon Steel, hardened cone (or cup) point engaging screw

**Function** — For bracing pipe against sway and seismic disturbances, Functions as a longitudinal brace connection when attached to a lateral brace pipe. Bracing connection must be positioned as close as physically possible to the braced pipe (No more than 3" away). Must be used only with TOLCO bracing components. When used in conjunction with TOLCO Fig. 1000, this combination bracing restricts piping movement in tension and compression both laterally and longitudinally.

**Approvals** — Underwriter's Laboratories Listed in the USA (UL) and Canada (cUL). Included in our Seismic Restraints Catalog approved by the State of California Office of Statewide Health Planning and Development (OSHPD). For additional load, spacing and placement information relating to OSHPD projects, please refer to the TOLCO Seismic Restraint Systems Guidelines.

**Installation Instructions** — The Fig. 907 is a transitional component of a longitudinal 4-way sway brace assembly. It is intended to be installed with the longitudinal and lateral "bracing pipes", TOLCO structural attachment fittings, Fig. 909, 910 and 980 and the Fig. 1000 TOLCO "braced pipe" fitting, to form a complete bracing assembly. NFPA 13 and/or OSHPD guidelines should be followed.

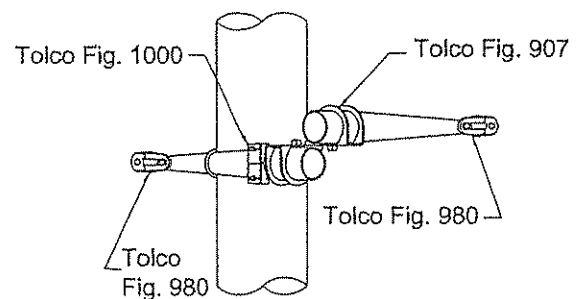
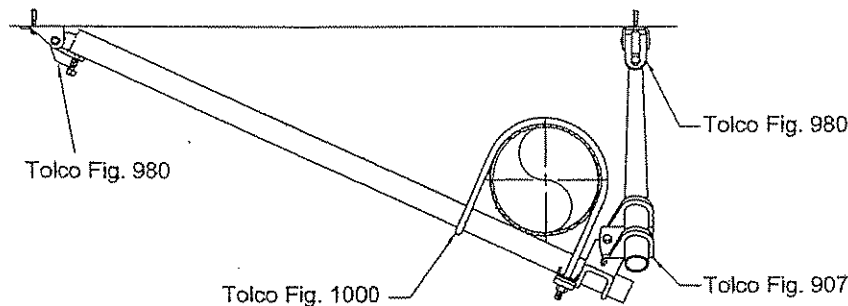
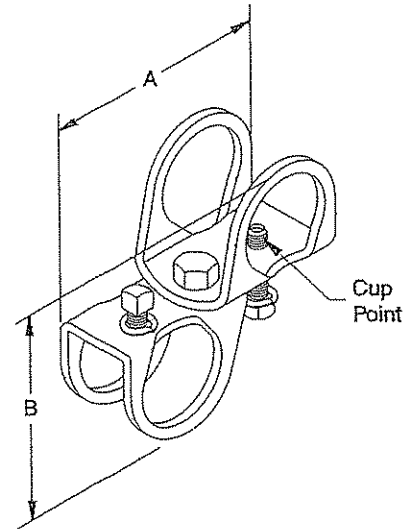
**To Install** — Attach the Fig. 907 over the lateral "bracing pipe" to within 3" of its position relative to the "braced pipe" connection. Adjust brace angle and tighten bolts until heads bottom out on surface.

**Finish** — Plain

**Note** — Available in Electro-Galvanized and HDG finish.

**Order By** — Figure number, bracing pipe sizes and finish.

Component of State of California OSHPD Approved Seismic Restraints System



Dimensions • Weights				
Pipe Size	A	B	Max. Design Load Lbs.*	Approx. Wt./100
1 x 1	4¾	4¾	655*	103
1 x 1¼	5¼	4¼	655*	107
1¼ x 1¼	5¾	5¼	655*	109

\* Load will accommodate up to 4" pipe at maximum spacing.

TOLCO® brand bracing components are designed to be compatible **ONLY** with other TOLCO® brand bracing components, resulting in a Listed seismic bracing assembly. **DISCLAIMER** — NIBCO does **NOT** warrant against the failure of TOLCO® brand bracing components, in the instance that such TOLCO® brand bracing components are used in combination with products, parts or systems which are not manufactured or sold under the TOLCO® brand. NIBCO shall **NOT** be liable under any circumstance for any direct or indirect, incidental or consequential damages of any kind, including but not limited to loss of business or profit, where non-TOLCO brand bracing components have been, or are used.

# Cast Iron Threaded Fittings Class 125, (Standard)



Square Head Plugs (Cored) Figure 387◊	Size		Weight			
			black		galv.	
	NPS	DN	lbs	kg	lbs	kg
	¾	20	0.13	0.06	0.14	0.06
	1	25	0.25	0.11	0.28	0.13
	1¼	32	0.39	0.18	0.41	0.18
	1½	40	0.50	0.23	0.52	0.23
	2	50	0.81	0.37	0.83	0.38
	2½	65	1.3	0.60	1.3	0.61
	3	80	1.9	0.85	1.9	0.87
	3½	90	2.5	1.1	2.6*	1.2*
	4	100	4.0	1.8	4.0	1.8

Countersunk Plugs Figure 390▲	Size		Weight			
			black		galv.	
	NPS	DN	lbs	kg	lbs	kg
	½	15	0.05	0.02	0.05	0.02
	¾	20	0.09	0.04	0.10*	0.05*
	1	25	0.20	0.09	0.20	0.09
	1¼	32	0.32	0.15	0.34	0.15
	1½	40	0.47	0.21	0.48	0.22
	2	50	0.84	0.38	1.3	0.59
	2½	65	1.4	0.64	2.0	0.91
	3	80	2.3	1.0	3.0	1.4
	3½	90	3.0	1.4	—	—
	4	100	3.8	1.7	3.9	1.8

Square Head Plugs (Solid) Figure 388	Size		Weight			
			black		galv.	
	NPS	DN	lbs	kg	lbs	kg
	½	15	0.10	0.05	0.10	0.05
	¾	20	0.17	0.08	0.18	0.08
	1	25	0.32	0.15	0.33	0.15
	1¼	32	0.53	0.24	0.55	0.25
	1½	40	0.76	0.34	0.77	0.35
	2	50	1.2	0.56	1.3	0.57
	2½	65	2.0	0.91	2.1	0.9
	3	80	3.2	1.4	3.3	1.5
	3½	90	4.4	2.0	•	•

Cap Figure 381	Size		Weight			
			black		galv.	
	NPS	DN	lbs	kg	lbs	kg
	2½	65	2.5	1.2	—	—
	3	80	4.1	1.9	—	—
	4	100	6.4	2.9	—	—
	5	125	11	4.9	—	—
	6	150	14	6.4	15	6.6
	8	200	27	12	28	13

Bar Plugs Cored Figure 389	Size		Weight			
			black		galv.	
	NPS	DN	lbs	kg	lbs	kg
	4	100	3.8	1.7	4.0	1.8
	5	125	6.5	2.9	6.8	3.1
	6	150	9.9	4.5	10	4.7
	8	200	20	9	21	10
Bar Plugs Solid Figure 380	Size		Weight			
			black		galv.	
	NPS	DN	lbs	kg	lbs	kg
	4	100	5.7	2.6	•	•
	5	125	9.6	4.4	•	•
	6	150	15	6.7	•	•
	8	200	•	•	•	•

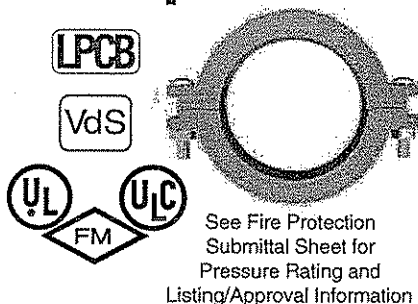
◊ ½, ¾, 1 NPS (6, 8 & 10 DN) plugs furnished in steel  
 s ½ and ¾ NPS (15 & 20 DN) countersunk plugs furnished in  
 malleable iron  
 • Not stocked

Note: See page PF-75 for pressure-temperature ratings.

\* POA.

## Grinnell Grooved Fire Protection Products Figure 772 Rigid Coupling - Patented

### General Description



The Figure 772 Rigid Coupling provides a rigid joint by firmly gripping along the circumference of the pipe grooves. Rigid couplings are preferred for dry pipe and freezer applications. Figure 772 Rigid Couplings are a proven dependable method of joining pipe and are an economical alternative to welding, threading or using flanges. It is capable of pressures up to 500 psig (3447 kPa) depending on pipe size and wall thickness when used in fire protection services.

Rigid Couplings are recommended for dry pipe and freezer applications.

#### WARNING

The Figure 772 Rigid Coupling described herein must be installed and maintained in compliance with this document, as well as with the applicable standards of the National Fire Protection Association, in addition to the standards of any other authorities having jurisdiction. Failure to do so may impair the performance of this device.

The owner is responsible for maintaining their fire protection system and devices in proper operating condition. The installing contractor or sprinkler manufacturer should be contacted with any questions.

### Technical Data

Figure: 772

Sizes: 1/4" - 12"

Approvals: UL, FM, ULC, VdS, and LPCB;  
See Fire Protection Submittal Sheet for exact Listing / Approval information.

**Housing:** Ductile iron conforming to ASTM A-536, Grade 65-45-12

**Protective Coatings:**

- Non-lead orange paint
- Fire brigade red (optional) non-lead paint
- Hot dipped galvanized conforming to ASTM A-153

**Bolt/Nuts:** Track Head Bolts - conforming to ASTM A-183, Zinc Plated, (Min. Tensile = 110,000 psi/758,422 kPa)  
Metric - conforming to ASTM F568M

**Gasket:** (specify when ordering)

- Grade "A" EPDM violet color code ambient to +150°F (+66°C) for fire protection systems. Not recommended for hot water systems.
- Tri-seal (Grade "E" EPDM), green color code for use in dry pipe or freezer systems.
- Prelubricated (Grade "A" EPDM)

(See Data Sheet TFP1895 for aid in selecting proper gasket)

### Ordering Procedure

When placing an order, indicate the full product name. Please specify the quantity, figure number, type of gasket, Grade "A" EPDM, Prelubricated (Grade "A" EPDM) or Grade "E" EPDM Tri-Seal, and size.

Grinnell Grooved Piping Products, valves, accessories and other products are available throughout the U.S., Canada, and internationally, through a network of distribution centers. You may write directly or call 215-362-0700 for the distributor nearest you.

### Care and Maintenance

The owner is responsible for the inspection, testing, and maintenance of their fire protection system and devices in accordance with the applicable standards of the National Fire Protection Association (e.g., NFPA 25), in addition to the standards of any authority having jurisdiction. The installing contractor or product manufacturer

should be contacted relative to any questions. Any impairment must be immediately corrected. It is recommended that automatic sprinkler systems be inspected, tested, and maintained by a qualified Inspection Service.

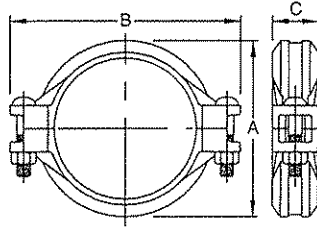
### Limited Warranty

Products manufactured by Tyco Fire Products are warranted solely to the original Buyer for ten (10) years against defects in material and workmanship when paid for and properly installed and maintained under normal use and service. This warranty will expire ten (10) years from date of shipment by Tyco Fire Products. No warranty is given for products or components manufactured by companies not affiliated by ownership with Tyco Fire Products or for products and components which have been subject to misuse, improper installation, corrosion, or which have not been installed, maintained, modified or repaired in accordance with applicable Standards of the National Fire Protection Association (NFPA), and/or the standards of any other Authorities Having Jurisdiction. Materials found by Tyco Fire Products to be defective shall be either repaired or replaced, at Tyco Fire Products' sole option. Tyco Fire Products neither assumes, nor authorizes any person to assume for it, any other obligation in connection with the sale of products or parts of products. Tyco Fire Products shall not be responsible for sprinkler system design errors or inaccurate or incomplete information supplied by Buyer or Buyer's representatives.

IN NO EVENT SHALL TYCO FIRE PRODUCTS BE LIABLE, IN CONTRACT, TORT, STRICT LIABILITY OR UNDER ANY OTHER LEGAL THEORY, FOR INCIDENTAL, INDIRECT, SPECIAL OR CONSEQUENTIAL DAMAGES, INCLUDING BUT NOT LIMITED TO LABOR CHARGES, REGARDLESS OF WHETHER TYCO FIRE PRODUCTS WAS INFORMED ABOUT THE POSSIBILITY OF SUCH DAMAGES, AND IN NO EVENT SHALL TYCO FIRE PRODUCTS' LIABILITY EXCEED AN AMOUNT EQUAL TO THE SALES PRICE.

**THE FOREGOING WARRANTY IS MADE IN LIEU OF ANY AND ALL OTHER WARRANTIES EXPRESS OR IMPLIED, INCLUDING WARRANTIES OF MERCHANTABILITY AND FITNESS FOR A PARTICULAR PURPOSE.**

## Figure 772 Grooved Coupling



Pipe		Max. *‡ End Gap	Max. † Pressure	Max. † End Load	Nominal Dimensions			Bolt Size** Dia. x Lg.	Net Wt. Lbs. Kg.
Size	O.D.				A	B	C		
	Inches mm	Inches mm	psi kPa	Lbs. N	Inches mm	Inches mm	Inches mm		
1¼"	1.660	0.06	300	649	2.75	4.38	1.81	¾" x 2¼" M10 x 57	1.0 0.5
	42.4	1.5	2,068	2,887	69.9	111.3	46.0		
1½"	1.900	0.08	500	1,417	3.00	4.62	1.81	¾" x 2¼" M10 x 57	1.0 0.5
	48.3	2.0	3,447	6,303	76.2	117.3	46.0		
2"	2.375	0.13	500	2,214	3.41	5.12	1.88	¾" x 2¼" M10 x 57	1.5 0.7
	60.3	3.3	3,447	9,848	86.6	130.0	47.8		
2½"	2.875	0.13	500	3,244	3.91	5.63	1.88	¾" x 2¼" M10 x 57	2.5 1.1
	73.0	3.3	3,447	14,430	99.3	143.0	47.8		
76.1mm	3.000	0.13	300	2,120	4.19	5.72	2.00	M10 x 57	2.6 1.2
	76.1	3.3	2,068	9,430	106.4	145.3	50.8		
3"	3.500	0.13	500	4,808	4.63	6.25	1.88	¾" x 2¼" M10 x 57	2.6 1.2
	88.9	3.3	3,447	21,387	117.6	158.8	47.8		
4"	4.500	0.19	500	7,948	5.81	7.50	1.97	¾" x 2¼" M10 x 57	3.5 1.6
	114.3	4.8	3,447	35,353	147.6	190.5	50.0		
139.7mm	5.500	0.19	300	7,127	7.02	9.72	2.06	M16 x 83	7.5 3.4
	139.7	4.8	2,068	31,701	178.3	246.9	52.3		
5"	5.563	0.19	300	7,288	7.09	9.71	2.04	¾" x 3¼" M16 x 83	7.5 3.4
	141.3	4.8	2,068	32,417	180.1	246.6	51.8		
165.1mm	6.500	0.19	300	9,950	8.09	10.53	2.13	M16 x 83	7.6 3.4
	165.1	4.8	2,068	44,258	205.5	267.5	54.1		
6"	6.625	0.19	400	13,782	8.09	10.53	2.13	¾" x 3¼" M16 x 83	7.6 3.4
	168.3	4.8	2,758	61,302	205.5	267.5	54.1		
8"	8.625	0.19	450	26,278	10.56	13.56	2.62	¾" x 4¼" M20 x 121	18.0 8.2
	219.1	4.8	3,103	116,885	268.2	344.4	66.5		
10"	10.750	0.13	250	22,679	12.84	16.41	2.62	1" x 6½" M24 x 165	24.6 11.2
	273.0	3.3	1,724	100,876	326.1	416.8	66.5		
12"	12.750	0.13	250	31,903	15.41	18.84	2.62	1" x 6½" M24 x 165	42.0 19.1
	323.9	3.3	1,724	141,905	391.4	478.5	66.5		

\* Maximum available gap between pipe ends. Minimum gap = 0.

† Maximum pressure and end load are total from all loads based on standard weight steel pipe. Pressure ratings and end loads may differ on other pipe materials and/or wall thickness. Contact Tyco Fire Products for details.

See Fire Protection Equipment Submittal Sheet for Listing and Approval pressure ratings.

\*\* Gold color coded metric bolt sizes are available upon request.

‡ Max End Gap is for cut grooved standard weight pipe. Values for roll grooved pipe will be ½ that of cut grooved.

Figure 772 Rigid Couplings have an Anti-Rotation Feature of "gripping teeth" along the coupling keys in sizes 1¼" - 4", which make the Figure 772 perfectly suited for "arm over" installations where the likelihood of rotation is greatest. This feature may eliminate the need of extra hangers to support the arm over due to increased rigidity and gripping force saving time and cost.

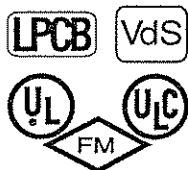
General Notes: It is the Designer's responsibility to select products suitable for the intended service and to ensure that pressure ratings and performance data is not exceeded. Always read and understand the installation instructions (IH-1000). Never remove any piping component or correct or modify any piping deficiencies without first depressurizing and draining the system. Material and gasket selection should be verified to be compatible for the specific application.



Certified Company

## Grinnell Grooved Fire Protection Products Grooved Fittings

### General Description



See Fire Protection Submittal Sheet for Pressure Rating and Listing/Approval Information

The grooved fittings provide an economical and efficient method of changing direction, adding an outlet, reducing, or capping grooved piping systems. Grooved fittings are available in durable ductile iron or fabricated steel as indicated.

**Note:** Figure 510S and 519S fittings are special short radius fittings with smaller center to end dimensions than standard grooved fittings. Depending on the size and coupling used, there may be interferences at the bolt pads that require repositioning of the coupling orientation. The use of flange adapters is not recommended with Figures 510S and 519S fittings. Contact Tyco Fire Products for details.

#### WARNING

*The Fittings described herein must be installed and maintained in compliance with this document, as well as with the applicable standards of the National Fire Protection Association, in addition to the standards of any other authorities having jurisdiction. Failure to do so may impair the performance of this device.*

*The owner is responsible for maintaining their fire protection system and devices in proper operating condition. The installing contractor or sprinkler manufacturer should be contacted with any questions.*

### Technical Data

#### Approvals:

UL, FM, ULC, VdS, and LPCB;

**Note:** See Fire Protection Submittal Sheet for exact Listing / Approval information.

#### Material:

Cast: Figures: 201, 210, 219, 250, 260, 501, 510, 519, 510DE, 501S, 510S and 519S -

Ductile iron conforming to ASTM A-536, Grade 65-45-12

Fabricated Steel: Figures 391, 392, 393, 312, 313, 321, 327, 341 and 350 - Carbon Steel, (Sizes 1 $\frac{1}{4}$ " - 6" are Schedule 40); (Sizes 8" - 12" are Schedule 30), conforming to ASTM A-53 Grade B

#### Protective Coatings:

- Non-lead orange paint
- Fire brigade red (optional) non-lead paint
- Hot dipped galvanized conforming to ASTM A-153

### Ordering Procedure

When placing an order, indicate the full product name. Please specify the quantity, figure number, wall thickness, and size.

Grinnell Grooved Piping Products, valves, accessories and other products are available throughout the U.S., Canada, and internationally, through a network of distribution centers. You may write directly or call 215-362-0700 for the distributor nearest you.

### Care and Maintenance

The owner is responsible for the inspection, testing, and maintenance of their fire protection system and devices in accordance with the applicable standards of the National Fire Protection Association (e.g., NFPA 25), in addition to the standards of any authority having jurisdiction. The installing contractor or product manufacturer should be contacted relative to any questions. Any impairment must be immediately corrected. It is recommended that automatic sprinkler systems be inspected, tested, and maintained by a qualified Inspection Service.

### Limited Warranty

Products manufactured by Tyco Fire Products are warranted solely to the original Buyer for ten (10) years against defects in material and workmanship when paid for and properly installed and maintained under normal use and service. This warranty will expire ten (10) years from date of shipment by Tyco Fire Products. No warranty is given for products or components manufactured by companies not affiliated by ownership with Tyco Fire Products or for products and components which have been subject to misuse, improper installation, corrosion, or which have not been installed, maintained, modified or repaired in accordance with applicable Standards of the National Fire Protection Association (NFPA), and/or the standards of any other Authorities Having Jurisdiction. Materials found by Tyco Fire Products to be defective shall be either repaired or replaced, at Tyco Fire Products' sole option. Tyco Fire Products neither assumes, nor authorizes any person to assume for it, any other obligation in connection with the sale of products or parts of products. Tyco Fire Products shall not be responsible for sprinkler system design errors or inaccurate or incomplete information supplied by Buyer or Buyer's representatives.

IN NO EVENT SHALL TYCO FIRE PRODUCTS BE LIABLE, IN CONTRACT, TORT, STRICT LIABILITY OR UNDER ANY OTHER LEGAL THEORY, FOR INCIDENTAL, INDIRECT, SPECIAL OR CONSEQUENTIAL DAMAGES, INCLUDING BUT NOT LIMITED TO LABOR CHARGES, REGARDLESS OF WHETHER TYCO FIRE PRODUCTS WAS INFORMED ABOUT THE POSSIBILITY OF SUCH DAMAGES, AND IN NO EVENT SHALL TYCO FIRE PRODUCTS' LIABILITY EXCEED AN AMOUNT EQUAL TO THE SALES PRICE.

**THE FOREGOING WARRANTY IS MADE IN LIEU OF ANY AND ALL OTHER WARRANTIES EXPRESS OR IMPLIED, INCLUDING WARRANTIES OF MERCHANTABILITY AND FITNESS FOR A PARTICULAR PURPOSE.**

# Figures 201, 210, 219, and 260

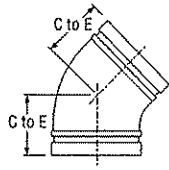


Figure 201

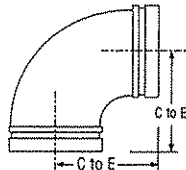


Figure 210

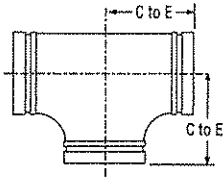


Figure 219

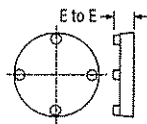


Figure 260

Nominal Size	Figure 201 45° Elbow		Figure 210 90° Elbow		Figure 219 Tee		Figure 260† End Cap	
	C to E Inches mm	Appx. Wt. Lbs. Kg.	C to E Inches mm	Appx. Wt. Lbs. Kg.	C to E Inches mm	Appx. Wt. Lbs. Kg.	E to E Inches mm	Appx. Wt. Lbs. Kg.
1 1/4"	1.75 44.5	0.9 0.4	2.75 69.9	1.0 0.5	2.75 69.9	1.4 0.6	0.88 22.4	0.4 0.2
1 1/2"	1.75 44.5	1.1 0.5	2.75 69.9	1.2 0.5	2.75 69.9	1.8 0.8	0.88 22.4	0.6 0.3
2"	2.00 50.8	1.8 0.8	3.25 82.6	2.0 0.9	3.25 82.6	2.7 1.2	0.88 22.4	0.9 0.4
2 1/2"	2.25 57.2	2.2 1.0	3.75 95.3	3.0 1.4	3.75 95.3	5.8 2.6	0.88 22.4	0.9 0.4
76.1mm	2.25 57.2	2.2 1.0	3.75 95.3	3.0 1.4	3.75 95.3	5.8 2.6	0.94 23.9	1.1 0.5
3"	2.50 63.5	3.5 1.6	4.25 108.0	4.5 2.0	4.25 108.0	7.0 3.2	0.88 22.4	1.1 0.5
108.0mm	2.88 73.0	5.5 2.5	4.75 120.7	8.5 3.9	4.75 120.7	11.5 5.2	-	-
4"	3.00 76.2	5.2 2.4	5.00 127.0	8.5 3.9	5.00 127.0	11.8 5.4	1.00 25.4	2.6 1.2
133.0mm	3.25 82.6	7.7 3.5	5.25 133.4	11.3 5.1	5.25 133.4	10.6 4.8	-	-
139.7mm	3.25 82.6	7.7 3.5	5.50 139.7	11.3 5.1	5.50 139.7	15.3 6.9	0.92 23.4	4.7 2.1
5"	3.25 82.6	8.5 3.9	5.50 139.7	13.5 6.1	5.50 139.7	17.0 7.7	1.00 25.4	5.0 2.3
159.0mm	3.50 88.9	12.0 5.4	6.00 152.4	14.6 6.6	6.00 152.4	13.9 6.3	-	-
165.1mm	3.50 88.9	12.0 5.4	6.50 165.1	18.5 8.4	6.50 165.1	26.0 11.8	1.00 25.4	7.5 3.4
6"	3.50 88.9	12.0 5.4	6.50 165.1	18.5 8.4	6.50 165.1	26.0 11.8	1.00 25.4	7.5 3.4
216.3mm	4.25 108.0	23.0 10.4	7.75 196.9	36.5 16.6	7.75 196.9	45.0 20.4	-	-
8"	4.25 108.0	23.0 10.4	7.75 196.9	36.5 16.6	7.75 196.9	45.0 20.4	1.19 30.2	12.8 5.8
10"	4.75 120.7	31.0 14.1	9.00 228.6	60.0 27.2	9.00 228.6	72.1 32.7	1.25 31.8	20.0 9.1
12"	5.25 133.4	40.0 18.1	10.00 254.0	67.0 30.4	10.00 254.0	92.5 42.0	1.25 31.8	36.0 16.3

† - Available with tapped plugs, contact Tyco Fire & Building Products.

Friction Resistance* (Expressed as Equivalent Straight Pipe)					
Size Inches mm	Elbow		Tee		
	90° Feet Meters	45° Feet Meters	Branch Feet Meters	Run Feet Meters	Run Feet Meters
1 1/4	1.9	1.0	4.8	1.9	1.9
42.4	0.6	0.3	1.5	0.6	0.6
1 1/2	2.3	1.2	5.8	2.3	2.3
48.3	0.7	0.4	1.8	0.7	0.7
2	3.2	1.6	8.0	3.2	3.2
60.3	1.0	0.5	2.5	1.0	1.0
2 1/2	3.9	2.0	9.8	3.9	3.9
73.0	1.2	0.6	3.0	1.2	1.2
76.1mm	4.1	2.1	10.3	4.1	4.1
	1.2	0.6	3.1	1.2	1.2
3	4.9	2.4	12.2	4.9	4.9
88.9	1.5	0.7	3.7	1.5	1.5
108.0mm	6.5	3.3	16.3	6.5	6.5
	2.0	1.0	5.0	2.0	2.0
4	6.5	3.3	16.3	6.5	6.5
114.3	2.0	1.0	5.0	2.0	2.0
133.0mm	8.0	4.0	20.0	8.0	8.0
	2.4	1.2	6.1	2.4	2.4
139.7mm	8.0	4.1	20.0	8.0	8.0
	2.4	1.3	6.1	2.4	2.4
5	8.2	4.1	20.5	8.2	8.2
141.3	2.5	1.3	6.3	2.5	2.5
159.0mm	9.5	4.8	23.8	9.5	9.5
	2.9	1.4	7.2	2.9	2.9
165.1mm	9.5	4.8	23.8	9.5	9.5
	2.9	1.4	7.2	2.9	2.9
6	9.9	5.0	24.8	9.9	9.9
168.3	3.0	1.5	7.6	3.0	3.0
216.3mm	13.1	6.6	32.8	13.1	13.1
	4.0	2.0	10.0	4.0	4.0
8	13.1	6.6	32.8	13.1	13.1
219.1	4.0	2.0	10.0	4.0	4.0
10	16.5	8.3	41.3	16.5	16.5
273.0	5.0	2.5	12.6	5.0	5.0
12	19.9	9.9	49.7	19.9	19.9
323.4	6.1	3.0	15.1	6.1	6.1

For reducing tees and branches, use the value that is corresponding to the branch size. Example: for 8" x 8" x 2" tee, the branch value 2" is 8.0 feet.

\* Friction resistance for all elbows and tees except Figures 510S and 519S.

# Figures 501, 510, 519 and 510DE

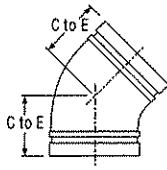


Figure 501

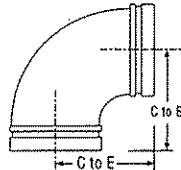


Figure 510

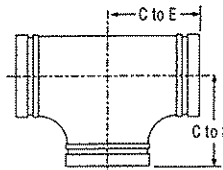


Figure 519

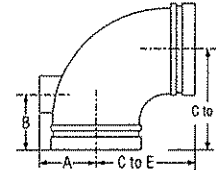


Figure 510DE

Nominal Size	Figure 501 45° Elbow		Figure 510 90° Elbow		Figure 519 Tee		Figure 510DE 90° Drain Elbow			
	C to E Inches mm	Appx. Wt. Lbs. Kg.	C to E Inches mm	Appx. Wt. Lbs. Kg.	C to E Inches mm	Appx. Wt. Lbs. Kg.	C to E Inches mm	A Inches mm	B Inches mm	Appx. Wt. Lbs. Kg.
1 1/4"	1.75 44.5	0.9 0.4	2.75 69.9	1.0 0.5	2.75 69.9	1.4 0.6	-	-	-	-
1 1/2"	1.75 44.5	1.1 0.5	2.75 69.9	1.2 0.5	2.75 69.9	1.8 0.8	-	-	-	-
2"	2.00 50.8	1.8 0.8	3.25 82.6	2.0 0.9	3.25 82.6	2.7 1.2	-	-	-	-
2 1/2"	2.25 57.2	2.2 1.0	3.75 95.3	3.0 1.4	3.75 95.3	5.8 2.6	3.75 95.3	2.00 50.8	2.75 69.9	2.7 1.2
3"	2.50 63.5	3.5 1.6	4.25 108.0	4.5 2.0	4.25 108.0	7.0 3.2	4.25 108.0	2.34 59.4	2.75 69.9	3.7 1.7
4"	3.00 76.2	5.2 2.4	5.00 127.0	8.5 3.9	5.00 127.0	11.8 5.4	5.00 127.0	2.85 72.4	2.75 69.9	7.0 3.2
5"	3.25 82.6	8.5 3.9	5.50 139.7	13.5 6.1	5.50 139.7	17.0 7.7	5.50 139.7	3.38 85.9	2.75 69.9	13.0 5.9
6"	3.50 88.9	12.0 5.4	6.50 165.1	18.5 8.4	6.50 165.1	26.0 11.8	6.50 165.1	3.92 99.6	2.75 69.9	13.4 6.1
8"	4.25 108.0	23.0 10.4	7.75 196.9	36.5 16.6	7.75 196.9	45.0 20.4	7.75 196.9	4.95 125.7	2.75 69.9	26.3 11.9

# Figures 501S, 510S and 519S

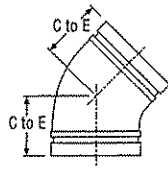


Figure 501S

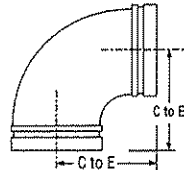


Figure 510S\*

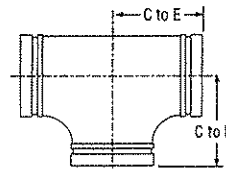


Figure 519S\*

Friction Resistance 501S, 510S & 519S (Expressed as Equivalent Straight Pipe)				
Size Inches mm	Elbow		Tee	
	90° Feet Meters	45° Feet Meters	Branch Feet Meters	Run Feet Meters
2 60.3	3.2 1.0	1.6 0.5	8.0 2.5	3.2 1.0
2 1/2 73.0	3.9 1.2	2.0 0.6	9.8 3.0	3.9 1.2
76.1mm	4.1 1.2	2.1 0.6	10.3 3.1	4.1 1.2
3 88.9	4.9 1.5	2.4 0.7	12.2 3.7	4.9 1.5
4 114.3	6.5 2.0	3.3 1.0	16.3 5.0	6.5 2.0
139.7mm	8.0 2.4	4.1 1.3	20.0 6.1	8.0 2.4
5 141.3	8.2 2.5	4.1 1.3	20.5 6.3	8.2 2.5
165.1mm	9.5 2.9	4.8 1.4	23.8 7.2	9.5 2.9
6 168.3	9.9 3.0	5.0 1.5	24.8 7.6	9.9 3.0
8 219.1	13.1 4.0	6.6 2.0	32.8 10.0	13.1 4.0

Nominal Size	Figure 501S 45° Elbow		Figure 510S 90° Elbow		Figure 519S Tee	
	C to E Inches mm	Appx. Wt. Lbs. Kg.	C to E Inches mm	Appx. Wt. Lbs. Kg.	C to E Inches mm	Appx. Wt. Lbs. Kg.
2"	2.00 50.8	1.8 0.8	2.75 69.9	1.5 0.7	2.75 69.9	2.1 1.0
2 1/2"	2.25 57.2	2.2 1.0	3.00 76.2	2.2 1.0	3.00 76.2	3.0 1.4
76.1mm	2.25 57.2	2.2 1.0	3.00 76.2	2.3 1.0	3.00 76.2	3.1 1.4
3"	2.50 63.5	3.5 1.6	3.38 85.9	3.0 1.3	3.38 85.9	4.1 1.9
4"	3.00 76.2	5.2 2.4	4.00 101.6	5.6 2.6	4.00 101.6	7.7 3.5
139.7mm	3.25 82.6	7.7 3.5	4.88 124.0	8.6 3.9	4.88 124.0	12.0 5.4
5"	3.25 82.6	8.5 3.9	4.88 124.0	8.8 3.9	4.88 124.0	12.0 5.4
165.1mm	3.50 88.9	12.0 5.4	5.50 139.7	11.00 5.0	5.50 139.7	15.0 6.8
6"	3.50 88.9	12.0 5.4	5.50 139.7	11.2 5.1	5.50 139.7	15.2 6.9
8"	4.25 108.0	23.0 10.4	6.88 174.8	23.4 10.6	6.88 174.8	31.2 14.2

\*Note: Figure 510S and 519S fittings are special short radius fittings with smaller center to end dimensions than standard grooved fittings. Depending on the size and coupling used, there may be interferences at the bolt pads which requires repositioning of the coupling orientation. The use of flange adapters is not recommended with Figures 510S and 519S fittings. Contact Tyco Fire Products for details.

# Figures 250 and 350

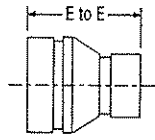


Figure 250  
Cast

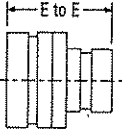


Figure 350  
Fabricated  
Sizes 3" to 6"

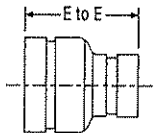
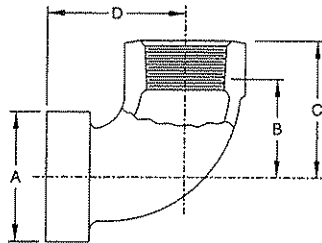


Figure 350  
Fabricated  
Sizes 8" to 12"

Figures 250 and 350 Concentric Reducer - Groove x Groove								
Nominal Size Inches	E to E Inches mm	Appx. Wt. Lbs. Kg.	Nominal Size Inches	E to E Inches mm	Appx. Wt. Lbs. Kg.	Nominal Size Inches	E to E Inches mm	Appx. Wt. Lbs. Kg.
*2 x 1¼	2.50 63.5	1.0 0.5	*139.7mm x 3	3.50 88.9	4.2 1.9	*6 x 5	4.00 101.6	5.8 2.6
*2 x 1½	2.50 63.5	1.3 0.6	*139.7mm x 4	3.50 88.9	4.4 2.0	8 x 2	5.00 127.0	12.2 5.5
*2½ x 2	2.50 63.5	1.2 0.5	5 x 1½	3.50 88.9	4.6 2.1	8 x 2½	5.00 127.0	12.1 5.5
*76.1mm x 1½	2.50 63.5	1.5 0.7	5 x 2	3.50 88.9	4.6 2.1	8 x 3	5.00 127.0	12.0 5.5
*76.1mm x 2	2.50 63.5	1.6 0.8	5 x 2½	3.50 88.9	4.5 2.0	8 x 4	5.00 127.0	11.9 5.4
3 x 1¼	2.50 63.5	1.3 0.6	5 x 3	3.50 88.9	4.4 2.0	8 x 5	5.00 127.0	11.3 5.1
3 x 1½	2.50 63.5	1.3 0.6	*5 x 4	3.50 88.9	4.5 2.0	8 x 6	5.00 127.0	10.8 4.9
*3 x 2	2.50 63.5	1.3 0.6	*165.1mm x 3	4.00 101.6	5.5 2.5	10 x 4	6.00 152.4	21.9 10.0
*3 x 2½	3.00 76.2	1.5 0.7	*165.1mm x 4	4.00 101.6	6.0 2.7	10 x 5	6.00 152.4	21.6 9.8
*3 x 76.1mm	3.00 76.2	2.0 0.9	*165.1mm x 139.7mm	4.00 101.6	5.6 2.5	10 x 6	6.00 152.4	21.1 9.6
4 x 1¼	3.00 76.2	2.2 1.0	*6 x 2	4.00 101.6	6.0 2.7	10 x 8	6.00 152.4	19.5 8.9
4 x 1½	3.00 76.2	2.3 1.0	6 x 2½	4.00 101.6	6.0 2.7	12 x 4	7.00 177.8	28.0 12.7
*4 x 2	3.00 76.2	2.3 1.0	*6 x 76.1mm	4.00 101.6	6.0 2.7	12 x 6	7.00 177.8	30.0 13.6
*4 x 2½	3.00 76.2	2.3 1.0	6 x 3	4.00 101.6	6.0 2.7	12 x 8	7.00 177.8	28.0 12.7
*4 x 76.1mm	3.00 76.2	3.2 1.5	*6 x 4	4.00 101.6	5.9 2.7	12 x 10	7.00 177.8	33.0 15.0
4 x 3	3.00 76.2	2.6 1.2	*6 x 139.7mm	4.00 101.6	6.3 2.9			

Note: Sizes marked with an asterisk (\*) are only available in Figure 250 Cast.  
 Sizes without an asterisk are only available in Figure 350 Fabricated.

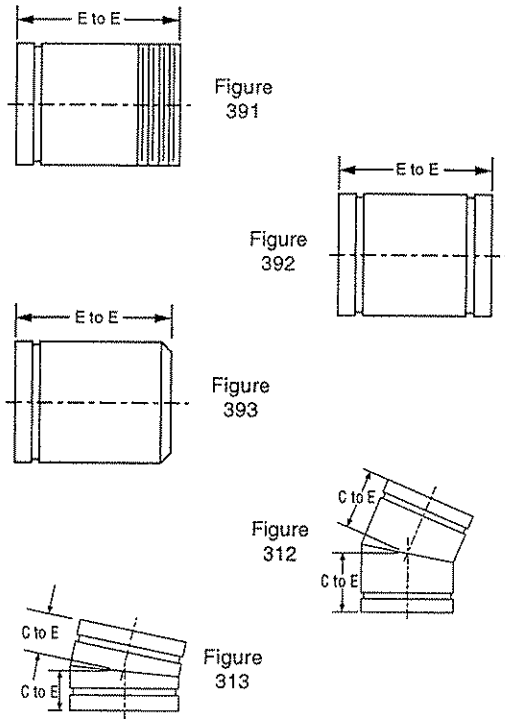
## ADA CAP® Patented



Pipe Size Inches	Outlet NPT* Inches	Nominal Dimensions				Net Wt. Lbs. Kg.
		O.D. A Inches mm	Takeout B Inches mm	Center to End C Inches mm D Inches mm		
1½	½	1.900 48.3	1.25 31.8	1.75 44.5	1.89 48.0	0.77 0.3
	¾		1.25 31.8	1.75 44.5	1.89 48.0	0.77 0.3
	1		1.37 34.8	2.00 50.8	2.02 51.3	0.88 0.4
2	½	2.375 60.3	1.25 31.8	1.75 44.5	1.89 48.0	0.92 0.4
	¾		1.25 31.8	1.75 44.5	1.89 48.0	0.92 0.4
	1		1.37 34.8	2.00 50.8	2.02 51.3	1.06 0.5
2½	½	2.875 73.0	1.47 37.3	1.97 50.0	1.89 48.0	1.28 0.6
	¾		1.47 37.3	1.97 50.0	1.89 48.0	1.28 0.6
	1		1.37 34.8	2.00 50.8	2.02 51.3	1.50 0.7

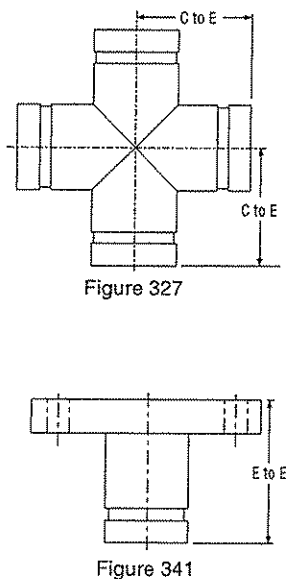
\* ISO-7 threaded outlets are available upon request.

# Figures 391, 392, 393, 312 and 313



Nominal Size	Figures 391, 392 and 393 Adapter Nipples		Figure 312 22 1/2° Elbow		Figure 313 11 1/4° Elbow	
	E to E Inches mm	Appx. Wt. Lbs. Kg.	C to E Inches mm	Appx. Wt. Lbs. Kg.	C to E Inches mm	Appx. Wt. Lbs. Kg.
1 1/4"	4.00 101.6	0.8 0.4	1.75 44.5	0.4 0.2	1.38 35.1	0.4 0.2
1 1/2"	4.00 101.6	0.9 0.4	1.75 44.5	0.5 0.2	1.38 35.1	0.5 0.2
2"	4.00 101.6	1.2 0.5	1.88 47.8	0.6 0.3	1.38 35.1	0.6 0.3
2 1/2"	4.00 101.6	1.9 0.9	2.00 50.8	0.7 0.3	1.50 38.1	1.1 0.5
3"	4.00 101.6	2.5 1.1	2.25 57.2	1.4 0.6	1.50 38.1	1.2 0.5
4"	6.00 152.4	5.5 2.5	2.63 66.8	2.4 1.1	1.75 44.5	2.2 1.0
5"	6.00 152.4	7.4 3.4	2.88 73.2	4.1 1.9	2.00 50.8	3.3 1.5
6"	6.00 152.4	9.5 4.3	3.13 79.5	5.6 2.5	2.00 50.8	4.6 2.1
8"	6.00 152.4	14.2 6.4	3.88 98.6	11.1 5.0	2.00 50.8	8.7 3.9
10"	8.00 203.2	27.0 12.2	4.38 11.3	14.0 6.4	2.13 54.1	9.1 4.1
12"	8.00 203.2	33.0 15.0	4.88 124.0	22.0 10.0	2.25 57.2	16.7 7.6

# Figures 327 and 341



Nominal Size	Figure 327 Cross		Figure 341 150 lbs. Flange Adapter	
	C to E Inches mm	Appx. Wt. Lbs. kg.	E to E Inches mm	Appx. Wt. Lbs. kg.
1 1/4"	2.75 69.6	2.0 0.9	4.00 101.6	2.8 1.3
1 1/2"	2.75 69.9	2.2 2.0	4.00 101.6	3.2 1.5
2"	3.25 82.6	2.7 1.2	4.0 101.6	5.2 2.4
2 1/2"	3.75 95.3	5.0 2.3	4.00 101.6	8.0 3.6
3"	4.25 108.0	7.1 3.2	4.00 101.6	10.2 4.6
4"	5.00 127.0	11.9 5.4	6.00 152.4	17.2 7.8
5"	5.50 139.7	17.1 7.8	6.00 152.4	21.4 9.7
6"	6.50 165.1	27.5 12.5	6.00 152.4	26.0 11.8
8"	7.75 196.9	47.0 21.3	6.00 152.4	38.4 17.4
10"	9.00 228.6	68.0 30.8	8.00 203.2	65.0 29.5
12"	10.00 254.0	107.0 48.5	8.00 203.2	91.0 41.3

# Figure 321

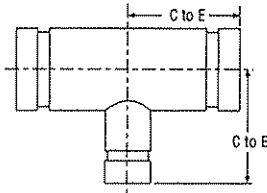


Figure 321

Figure 321 Reducing Tee					
Nominal Size Inches	C to E Inches <i>mm</i>	Appx. Wt. Lbs. <i>Kg.</i>	Nominal Size Inches	C to E Inches <i>mm</i>	Appx. Wt. Lbs. <i>Kg.</i>
1½ x 1½ x 1¼	3.25 82.6	2.0 0.9	6 x 6 x 4	6.50 165.1	26.6 12.1
2 x 2 x 1½	3.25 82.6	2.7 1.2	6 x 6 x 5	6.50 165.1	27.0 12.2
2½ x 2½ x 1¼	3.75 95.3	4.2 1.9	8 x 8 x 2	7.75 196.9	36.2 16.4
2½ x 2½ x 1½	3.75 95.3	4.2 1.9	8 x 8 x 3	7.75 196.9	36.5 16.6
2½ x 2½ x 2	3.75 95.3	4.3 2.0	8 x 8 x 4	7.75 196.9	36.6 16.6
3 x 3 x 1½	4.25 108.0	5.3 2.4	8 x 8 x 5	7.75 196.9	36.8 16.7
3 x 3 x 2	4.25 108.0	5.5 2.5	8 x 8 x 6	7.75 196.9	37.0 16.8
3 x 3 x 2½	4.25 108.0	5.8 2.6	10 x 10 x 2	9.00 228.6	57.1 25.9
4 x 4 x 1¼	5.00 127.0	9.8 4.4	10 x 10 x 3	9.00 228.6	57.4 26.0
4 x 4 x 1½	5.00 127.0	9.9 4.5	10 x 10 x 4	9.00 228.6	57.6 26.1
4 x 4 x 2	5.00 127.0	10.1 4.6	10 x 10 x 5	9.00 228.6	57.8 26.2
4 x 4 x 2½	5.00 127.0	10.3 4.7	10 x 10 x 6	9.00 228.6	58.0 26.3
4 x 4 x 3	5.00 127.0	10.5 4.8	10 x 10 x 8	9.00 228.6	58.4 26.5
5 x 5 x 2	5.50 139.7	14.5 6.6	12 x 12 x 3	10.00 254.0	80.2 36.4
5 x 5 x 2½	5.50 139.7	14.8 6.7	12 x 12 x 4	10.00 254.0	80.5 36.5
5 x 5 x 3	5.50 139.7	15.2 6.9	12 x 12 x 5	10.00 254.0	80.7 36.6
5 x 5 x 4	5.50 139.7	15.8 7.2	12 x 12 x 6	10.00 254.0	80.9 36.7
6 x 6 x 2	6.50 165.1	26.5 11.9	12 x 12 x 8	10.00 254.0	91.4 41.5
6 x 6 x 2½	6.50 165.1	26.5 12.0	12 x 12 x 10	10.00 254.0	91.8 41.6
6 x 6 x 3	6.50 165.1	26.5 12.0			

General Notes: It is the Designer's responsibility to select products suitable for the intended service and to ensure that pressure ratings and performance data is not exceeded. Always read and understand the installation instructions (IH-1000). Never remove any piping component or correct or modify any piping deficiencies without first depressurizing and draining the system. Material and gasket selection should be verified to be compatible for the specific application.

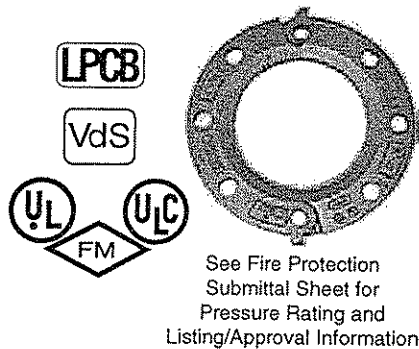


Certified Company

## Grinnell Grooved Fire Protection Products

### Figure 71 Flange Adapter

### General Description



The 71 Flange Adapter allows a direct transition from flanged components into a grooved piping system. Flange bolt patterns conform to ANSI Class 125 and 150 standards and PN16 as indicated.

#### WARNING

The Figure 71 Flange Adapter described herein must be installed and maintained in compliance with this document, as well as with the applicable standards of the National Fire Protection Association, in addition to the standards of any other authorities having jurisdiction. Failure to do so may impair the performance of this device. The owner is responsible for maintaining their fire protection system and devices in proper operating condition. The installing contractor or sprinkler manufacturer should be contacted with any questions.

### Technical Data

Figure: 71

Sizes: 2" - 12"

Approvals: UL, FM, ULC, VdS, and LPCB;

See Fire Protection Submittal Sheet for exact Listing / Approval information.

**Housing:** Ductile iron conforming to ASTM A-536, Grade 65-45-12

**Protective Coatings:**

- Non-lead orange paint
- Fire brigade red (optional) non-lead paint
- Hot dipped galvanized conforming to ASTM A-153

**Gasket:** (specify when ordering)

- Grade "E" EPDM, green color code.

(See Data Sheet TFP1895 for aid in selecting proper gasket)

### Ordering Procedure

When placing an order, indicate the full product name. Please specify the quantity, figure number, type of gasket, Grade "E" EPDM, and size. Grinnell Grooved Piping Products, valves, accessories and other products are available throughout the U.S., Canada, and internationally, through a network of distribution centers. You may write directly or call 215-362-0700 for the distributor nearest you.

### Care and Maintenance

The owner is responsible for the inspection, testing, and maintenance of their fire protection system and devices in accordance with the applicable standards of the National Fire Protection Association (e.g., NFPA 25), in addition to the standards of any authority having jurisdiction. The installing contractor or product manufacturer should be contacted relative to any questions. Any impairment must be immediately corrected. It is recommended that automatic sprinkler systems be inspected, tested, and maintained by a qualified Inspection Service.

### Limited Warranty

Products manufactured by Tyco Fire Products are warranted solely to the original Buyer for ten (10) years against defects in material and workmanship when paid for and properly installed and maintained under normal use and service. This warranty will expire ten (10) years from date of shipment by Tyco Fire Products. No warranty is given for products or components manufactured by companies not affiliated by ownership with Tyco Fire Products or for products and components which have been subject to misuse, improper installation, corrosion, or which have not been installed, maintained, modified or repaired in accordance with applicable Standards of the National Fire Protection Association (NFPA), and/or the standards of any other Authorities Having Jurisdiction. Materials found by Tyco Fire Products to be defective shall be either repaired or replaced, at Tyco Fire Products' sole option. Tyco Fire Products neither assumes, nor authorizes any person to assume for it, any other obligation in connection with the sale of products or parts of products. Tyco Fire Products shall not be responsible for sprinkler system design errors or inaccurate or incomplete information supplied by Buyer or Buyer's representatives.

IN NO EVENT SHALL TYCO FIRE PRODUCTS BE LIABLE, IN CONTRACT, TORT, STRICT LIABILITY OR UNDER ANY OTHER LEGAL THEORY, FOR INCIDENTAL, INDIRECT, SPECIAL OR CONSEQUENTIAL DAMAGES, INCLUDING BUT NOT LIMITED TO LABOR CHARGES, REGARDLESS OF WHETHER TYCO FIRE PRODUCTS WAS INFORMED ABOUT THE POSSIBILITY OF SUCH DAMAGES, AND IN NO EVENT SHALL TYCO FIRE PRODUCTS' LIABILITY EXCEED AN AMOUNT EQUAL TO THE SALES PRICE.

**THE FOREGOING WARRANTY IS MADE IN LIEU OF ANY AND ALL OTHER WARRANTIES EXPRESS OR IMPLIED, INCLUDING WARRANTIES OF MERCHANTABILITY AND FITNESS FOR A PARTICULAR PURPOSE.**

# Figure 71 Flange Adapter

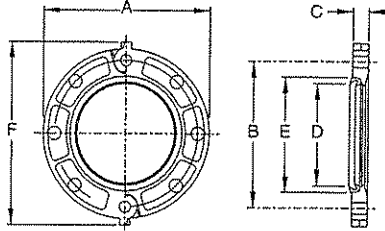


Figure 71 ANSI Calss 125 and 150

Pipe		Max † Pressure psi kPa	Max † End Load Lbs. N	Nominal Dimensions						Bolts ‡		Net Wt. lbs. kg
Nominal Size Inches	O.D. Inches mm			A Inches mm	B Inches mm	C Inches mm	*D Inches mm	*E Inches mm	F Inches mm	Size Dia. x Lg.	Qty.	
2	2.375 60.3	250 1,724	1,107 4,924	6.38 162.1	4.75 120.7	0.75 19.1	2.38 60.5	3.41 86.6	7.25 184.2	5/8" x 3"	4	3.0 1.4
2½	2.875 73.0	250 1,724	1,622 7,215	7.00 178.0	5.50 140.0	0.88 22.0	2.88 73.0	3.91 99.0	7.88 200.0	5/8" x 3"	4	5.0 2.3
3	3.500 88.9	250 1,724	2,404 10,693	7.50 190.5	6.00 152.4	0.94 23.9	3.50 88.9	4.53 115.1	9.88 251.0	5/8" x 3"	4	5.6 2.5
4	4.500 114.3	250 1,724	3,974 17,676	9.00 228.6	7.50 190.5	0.94 23.9	4.50 114.3	5.53 140.5	9.90 251.5	5/8" x 3"	8	7.0 3.2
5	5.563 141.3	250 1,724	6,073 27,013	10.00 254.0	8.50 215.9	1.00 25.4	5.56 141.2	6.72 170.7	11.38 289.1	¾" x 3½"	8	9.2 4.2
6	6.625 168.3	250 1,724	8,614 38,315	11.00 279.4	9.50 241.3	1.00 25.4	6.62 168.1	7.78 197.6	11.88 301.8	¾" x 3½"	8	10.0 4.5
8	8.625 219.1	250 1,724	14,599 64,936	13.50 342.9	11.75 298.5	1.13 28.7	8.62 218.9	9.94 252.5	14.38 365.3	¾" x 3½"	8	16.6 7.5
10	10.750 273.0	250 1,724	22,679 100,876	16.00 406.4	14.25 362.0	1.19 30.2	10.75 273.1	12.31 312.7	16.88 428.8	7/8" x 4"	12	21.8 9.9
12	12.750 323.9	250 1,724	31,903 141,905	19.00 482.6	17.00 431.8	1.25 31.8	12.75 323.9	14.31 363.5	20.00 508.0	7/8" x 4"	12	24.2 11.0

Figure 71 PN16

Pipe		Max † Pressure Bar	Max † End Load Lbs. N	Nominal Dimensions						Bolts ‡		Net Wt. lbs. kg
Nom. Size Inches mm	O.D. mm			A Inches mm	B Inches mm	C Inches mm	*D Inches mm	*E Inches mm	F Inches mm	Size Dia. x Lg.	Qty.	
2"	50	16	1,028 4,573	6.38 162.1	4.92 125.0	0.75 19.1	2.38 60.5	3.41 86.6	7.25 184.2	M16 x 76	4	3.0 1.4
2½"	65	16	1,640 7,295	7.28 184.9	5.71 145.0	0.88 22.4	3.00 76.1	4.03 102.4	8.09 205.5	M16 x 76	4	5.6 2.5
3"	80	16	2,232 9,928	7.88 200.2	6.30 160.0	0.94 23.9	3.50 88.9	4.53 115.1	8.75 222.3	M16 x 76	8	6.6 3.0
4"	100	16	3,690 16,413	9.00 228.6	7.09 180.1	0.94 23.9	4.50 114.3	5.53 140.5	9.90 251.5	M16 x 76	8	7.0 3.2
5"	125	16	5,512 24,517	9.84 249.9	8.27 210.1	1.00 25.4	5.50 139.7	6.53 165.9	10.69 271.5	M16 x 89	8	9.2 4.2
6"	150	16	7,698 34,241	11.25 285.8	9.45 240.0	1.00 25.4	6.50 165.1	7.53 191.3	12.12 307.8	M20 x 89	8	10.0 4.5
6"	150	16	7,997 35,571	11.00 279.4	9.49 241.1	1.00 25.4	6.62 168.1	7.78 197.6	11.88 301.8	M20 x 89	8	10.0 4.5
8"	200	16	13,555 60,293	13.38 339.9	11.61 294.9	1.13 28.7	8.62 218.9	9.94 252.5	14.31 363.5	M20 x 89	12	16.6 7.5
10	273.0	16	21,057 93,662	16.00 406.4	13.98 355.1	1.19 30.2	10.75 273.1	12.31 312.7	16.88 428.8	M22 x 102	12	21.8 9.9
12"	300	16	29,621 131,754	18.12 460.2	16.14 410.0	1.25 31.8	12.75 323.9	14.31 363.9	19.19 487.4	M24 x 102	12	28.0 12.7

† Maximum pressure and end load are total from all loads based on standard weight steel pipe. Pressure ratings and end loads may differ on other pipe materials and/or wall thickness. Contact Tyco Fire Products for details. See Fire Protection Equipment Submittal Sheet for Listing and Approval pressure ratings.

\* Dimensions D and E represent minimum and maximum sealing surfaces.

‡ Bolts and Nuts are not supplied. Bolt lengths are standard; it is the responsibility of the purchaser to verify correct length for the intended application.

General Notes: It is the Designer's responsibility to select products suitable for the intended service and to ensure that pressure ratings and performance data is not exceeded. Always read and understand the installation instructions (IH-1000). Never remove any piping component or correct or modify any piping deficiencies without first depressurizing and draining the system. Material and gasket selection should be verified to be compatible for the specific application.



Certified Company



**STENNIS RIVERINE & COMBATANT TRAINING**  
**FACILITY**  
**STENNIS SPACE CENTER**  
**STENNIS, MS 39529**

**FIRE PROTECTION/ SPRINKLER SYSTEMS**  
**OPERATIONS BUILDING 2440/2441**  
**BOAT STORAGE BUILDING 2442**

# **SECTION 5**

# **HYDRAULIC CALCULATIONS**

**SIMPLEXGRINNELL**  
**5800 JEFFERSON HWY SUITE A**  
**HARAHAN, LA. 70123**  
**PHONE 504-736-0104**  
**FAX 504-736-9292**

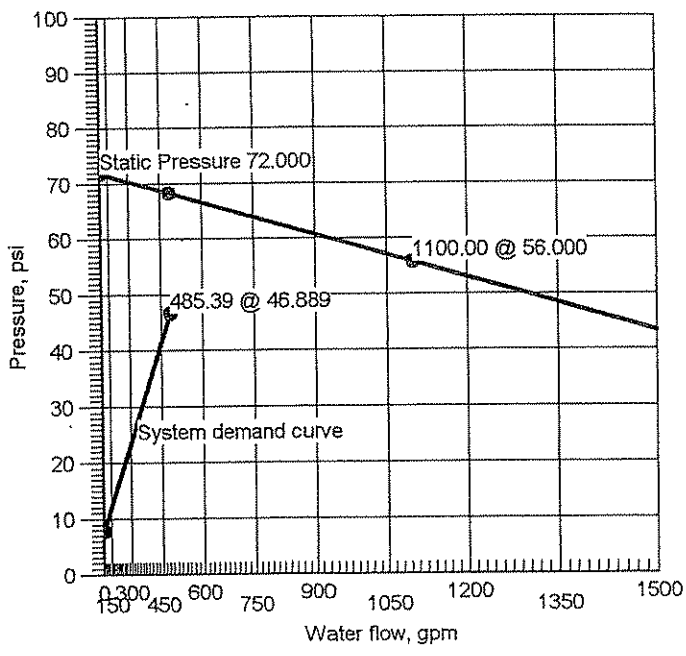
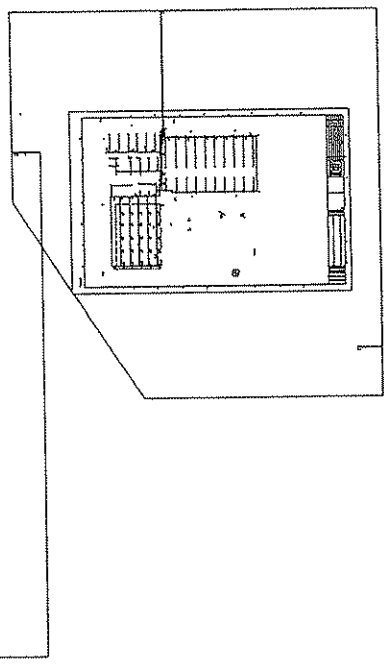
# Hydraulic Overview

Job Number <b>2440 CAGES</b>				Design Engineer	
Job Name <b>STENNIS RIVERINE BLDG 2440 CAGES</b>				Phone	FAX
Address 1 <b>255 1 OPERATIONS BLDG</b>				State Certification/License Number	
Address 2 <b>STENNIS SPACE CENTER</b>				AHJ	
City <b>STENNIS</b>	State <b>MS</b>	Zip Code	Job Site		

System		Area of Application <b>3000.00ft<sup>2</sup> (Actual 3073.29ft<sup>2</sup>)</b>	
Density <b>0.150gpm/ft<sup>2</sup></b>	Hose Streams <b>0.00</b>		
Most Demanding Sprinkler Data <b>5.6 K-Factor 19.00 at 11.511</b>	Number of Sprinklers Calculated <b>25</b>		
Coverage Per Sprinkler <b>120.00ft<sup>2</sup></b>	System Flow Demand <b>485.39</b>		
System Pressure Demand <b>46.889</b>	Pressure Result <b>+21.589 (31.5%)</b>		
Total Demand <b>485.39 @ 46.889</b>			

Supplies					Check Point Gauges			
Node	Flow(gpm)	Hose Flow(gpm)	Static(psi)	Residual(psi)	Identifier	Pressure(psi)	K-Factor(K)	Flow(gpm)
1	1100.00	0.00	72.000	56.000				

FP 3 BLDG 2440 2441 1st Floor R3 Supply at Node 1 (1100.00, 0.00, 72.000, 56.000)





# Summary Of Outflowing Devices

Job Number: 2440 CAGES  
Report Description: Ordinary Group I

Device		Actual Flow (gpm)	Minimum Flow (gpm)	K-Factor (K)	Pressure (psi)		
Sprinkler	113	19.29	19.00	5.6	11.860		
Sprinkler	115	19.39	19.00	5.6	11.987		
Sprinkler	118	19.65	19.00	5.6	12.314		
Sprinkler	133	20.20	19.00	5.6	13.009		
Sprinkler	135	21.16	19.00	5.6	14.282		
Sprinkler	106	19.09	19.00	5.6	11.619		
Sprinkler	110	19.16	19.00	5.6	11.703		
Sprinkler	114	19.33	19.00	5.6	11.915		
Sprinkler	120	19.69	19.00	5.6	12.362		
Sprinkler	134	20.36	19.00	5.6	13.225		
Sprinkler	105	19.07	19.00	5.6	11.600		
Sprinkler	109	19.12	19.00	5.6	11.655		
Sprinkler	112	19.22	19.00	5.6	11.786		
Sprinkler	116	19.43	19.00	5.6	12.044		
Sprinkler	122	19.86	19.00	5.6	12.577		
⇒ Sprinkler	101	19.00	19.00	5.6	11.511		
Sprinkler	103	19.03	19.00	5.6	11.554		
Sprinkler	108	19.11	19.00	5.6	11.640		
Sprinkler	111	19.21	19.00	5.6	11.772		
Sprinkler	117	19.44	19.00	5.6	12.055		
Sprinkler	102	19.01	19.00	5.6	11.524		
Sprinkler	104	19.04	19.00	5.6	11.558		
Sprinkler	107	19.10	19.00	5.6	11.636		
Sprinkler	854	19.16	19.00	5.6	11.709		
Sprinkler	855	19.26	19.00	5.6	11.823		

⇒ Most Demanding Sprinkler Data

# Hydraulic Analysis

Job Number: 2440 CAGES  
Report Description: Ordinary Group I

Pipe Type	Diameter	Flow	Velocity	HWC	Friction Loss	Length	Pressure
Downstream	Elevation	Discharge	K-Factor	Pt	Pn	Eq. Length	Summary
Upstream						Total Length	
Route 1							
1	1.0490	Q=19.00	7.05	C=120	0.118351	0'-10%	Pf 0.698
414	12'-1½	q=19.00	K=5.6	11.511	Spr(-11.511)	5'-0	Pe 0.388
CM	11'-2¾			12.598	PO(5'-0)	5'-10¾	Pv
414	2.1570	Q=9.43	0.83	C=120	0.000968	13'-5	Pf 0.013
408	11'-2¾			12.598			Pe
CM	11'-2¾			12.611		13'-5	Pv
408	2.1570	Q=28.50	2.50	C=120	0.007488	13'-5	Pf 0.100
401	11'-2¾			12.611			Pe
CM	11'-2¾			12.711		13'-5	Pv
401	2.1570	Q=47.59	4.18	C=120	0.019330	13'-2	Pf 0.255
390	11'-2¾			12.711			Pe
CM	11'-2¾			12.966		13'-2	Pv
390	2.1570	Q=66.88	5.87	C=120	0.036272	15'-6¾	Pf 1.145
362	11'-2¾			12.966		16'-0	Pe 0.533
CM	10'-0			14.643	LtE(3'-8¼), PO(12'-3¾)	31'-6¾	Pv
362	2.6350	Q=103.39	6.08	C=120	0.030638	9'-3	Pf 0.283
364	10'-0			14.643			Pe
CM	10'-0			14.927		9'-3	Pv
364	2.6350	Q=174.84	10.29	C=120	0.080974	9'-0	Pf 0.729
366	10'-0			14.927			Pe
CM	10'-0			15.655		9'-0	Pv
366	2.6350	Q=257.05	15.12	C=120	0.165190	9'-3	Pf 1.528
370	10'-0			15.655			Pe
CM	10'-0			17.183		9'-3	Pv
370	2.6350	Q=358.43	21.09	C=120	0.305559	8'-6	Pf 2.597
375	10'-0			17.183			Pe
CM	10'-0			19.781		8'-6	Pv
375	4.2600	Q=358.43	8.07	C=120	0.029449	0'-9	Pf 0.022
377	10'-0			19.781			Pe
CM	10'-0			19.803		0'-9	Pv
377	4.2600	Q=485.39	10.93	C=120	0.051606	17'-11¾	Pf 1.743
530	10'-0			19.803		15'-9½	Pe
CM	10'-0			21.546	2LtE(7'-10¾)	33'-9¼	Pv
530	4.2600	Q=468.81	10.55	C=120	0.048391	6'-5¾	Pf 1.970
313	10'-0			21.546		34'-2¾	Pe -2.168
CM	15'-0			21.348	LtE(7'-10¾), T(26'-4)	40'-8½	Pv
313	4.2600	Q=356.58	8.03	C=120	0.029168	13'-4	Pf 0.389
297	15'-0			21.348			Pe 0.000
CM	15'-0			21.737		13'-4	Pv
297	4.2600	Q=364.28	8.20	C=120	0.030345	19'-6	Pf 0.592
198	15'-0			21.737			Pe
CM	15'-0			22.329		19'-6	Pv
198	4.2600	Q=373.16	8.40	C=120	0.031728	14'-7½	Pf 0.464
284	15'-0			22.329			Pe
CM	15'-0			22.793		14'-7½	Pv
284	6.3570	Q=373.16	3.77	C=120	0.004517	0'-0	Pf 0.000
261	15'-0			22.793			Pe 0.000
CM	15'-0			22.793		0'-0	Pv
261	6.3570	Q=485.39	4.91	C=120	0.007347	4'-3½	Pf 0.198
163	15'-0			22.793		22'-7½	Pe -0.000
CM	15'-0			22.991	2LtE(11'-3¾)	26'-11	Pv
163	6.3570	Q=485.39	4.91	C=120	0.007347	6'-9	Pf 0.050
161	15'-0			22.991			Pe 2.926
CM	8'-3			25.967		6'-9	Pv
161	6.3570	Q=485.39	4.91	C=120	0.007347	1'-1	Pf 0.513
84	8'-3			25.967		68'-9¾	Pe 1.838
CM	4'-0¼			28.318	2f(-0.000), CV(40'-2¾), BV(12'-7), CV(16'-0)	69'-10¾	Pv
84	6.0650	Q=485.39	5.39	C=120	0.009237	2'-0	Pf 0.111
7	4'-0¼			28.318		10'-0	Pe 1.305
CM	1'-0			29.734	BV(10'-0)	12'-0	Pv
7	8.3900	Q=485.39	2.82	C=140	0.001430	135'-2½	Pf 0.322
3	1'-0			29.734		89'-11	Pe 2.601
CM	-5'-0			32.657	E(30'-6½), T(59'-4½)	225'-1½	Pv
3	7.9800	Q=320.09	2.05	C=150	0.000744	303'-2¾	Pf 0.285
5	-5'-0			32.657		79'-11¾	Pe
CM	-5'-0			32.942	E(27'-2), T(52'-9¾)	383'-2½	Pv
5	7.9800	Q=485.39	3.11	C=150	0.001607	1'-11	Pf 0.035
11	-5'-0			32.942		19'-7½	Pe
CM	-5'-0			32.977	LtE(19'-7½)	21'-6½	Pv

# Hydraulic Analysis

Job Number: 2440 CAGES  
Report Description: Ordinary Group I

Pipe Type	Diameter	Flow	Velocity	HWC	Friction Loss	Length	Pressure
Downstream	Elevation	Discharge	K-Factor	Pt	Pn	Eq. Length	Summary
Upstream						Total Length	
UG	8.3900	Q=485.39	2.82	C=140		0.001430	17'-0" Pf 12.119
	-5'-0"			32.977			66'-2" Pe 0.434
	-6'-0"			45.529		3LI(22'-0%), BFP(-12.000)	83'-2" Pv
UG	7.9800	Q=485.39	3.11	C=150		0.001607	727'-3" Pf 1.360
12	-6'-0"			45.529			119'-2½" Pe
1	-6'-0"			46.889		2E(27'-2), 2GV(6'-0½), T(52'-9¾), S	846'-5¾" Pv
***** Route 2 *****							
SP	1.0490	Q=19.01	7.06	C=120		0.118471	0'-10¾" Pf 0.698
102	12'-1½"	q=19.01	K=5.6	11.524		Spr(-11.524)	5'-0" Pe 0.388
420	11'-2¾"			12.611		PO(5'-0)	5'-10¾" Pv
CM	2.1570	Q=28.58	2.51	C=120		0.007525	4'-7¼" Pf 0.155
420	11'-2¾"			12.611			16'-0" Pe 0.533
674	10'-0"			13.299		LtE(3'-8¼), PO(12'-3¾)	20'-7¼" Pv
CM	2.6350	Q=36.52	2.15	C=120		0.004467	9'-6" Pf 0.116
674	10'-0"			13.299			16'-5¾" Pe
671	10'-0"			13.415		PO(16'-5¾)	25'-11¾" Pv
CM	2.1570	Q=36.52	3.21	C=120		0.011841	78'-5½" Pf 1.206
671	10'-0"			13.415			23'-4½" Pe
360	10'-0"			14.621		3LtE(3'-8¼), PO(12'-3¾)	101'-10" Pv
CM	2.6350	Q=36.52	2.15	C=120		0.004467	5'-0" Pf 0.022
360	10'-0"			14.621			Pe
362	10'-0"			14.643			5'-0" Pv
***** Route 3 *****							
SP	1.0490	Q=19.03	7.07	C=120		0.118753	0'-10¾" Pf 0.700
103	12'-1½"	q=19.03	K=5.6	11.554		Spr(-11.554)	5'-0" Pe 0.388
415	11'-2¾"			12.642		PO(5'-0)	5'-10¾" Pv
CM	2.1570	Q=13.78	1.21	C=120		0.001953	13'-5" Pf 0.026
415	11'-2¾"			12.642			Pe
409	11'-2¾"			12.669			13'-5" Pv
CM	2.1570	Q=32.90	2.89	C=120		0.009765	13'-5" Pf 0.131
409	11'-2¾"			12.669			Pe
402	11'-2¾"			12.800			13'-5" Pv
CM	2.1570	Q=52.06	4.57	C=120		0.022821	13'-2" Pf 0.300
402	11'-2¾"			12.800			Pe
391	11'-2¾"			13.100			13'-2" Pv
CM	2.1570	Q=71.45	6.27	C=120		0.040991	15'-6¾" Pf 1.294
391	11'-2¾"			13.100			16'-0" Pe 0.533
364	10'-0"			14.927		LtE(3'-8¼), PO(12'-3¾)	31'-6¾" Pv
***** Route 4 *****							
SP	1.0490	Q=19.04	7.07	C=120		0.118793	0'-10¾" Pf 0.700
104	12'-1½"	q=19.04	K=5.6	11.558		Spr(-11.558)	5'-0" Pe 0.388
421	11'-2¾"			12.647		PO(5'-0)	5'-10¾" Pv
CM	2.1570	Q=24.29	2.13	C=120		0.005569	4'-11¾" Pf 0.117
421	11'-2¾"			12.647			16'-0" Pe 0.533
678	10'-0"			13.296		LtE(3'-8¼), PO(12'-3¾)	20'-11¾" Pv
CM	2.6350	Q=16.35	0.96	C=120		0.001011	9'-0" Pf 0.009
678	10'-0"			13.296			Pe
681	10'-0"			13.306			9'-0" Pv
CM	2.6350	Q=30.56	1.80	C=120		0.003213	9'-3" Pf 0.030
681	10'-0"			13.306			Pe
685	10'-0"			13.335			9'-3" Pv
CM	2.6350	Q=26.88	1.58	C=120		0.002534	9'-6" Pf 0.066
685	10'-0"			13.335			16'-5¾" Pe
688	10'-0"			13.401		PO(16'-5¾)	25'-11¾" Pv
CM	2.1570	Q=26.88	2.36	C=120		0.006718	4'-11¾" Pf 0.058
688	10'-0"			13.401			3'-8¼" Pe -0.533
668	11'-2¾"			12.926		LtE(3'-8¼)	8'-8" Pv
CM	2.1570	Q=46.13	4.05	C=120		0.018250	13'-5" Pf 0.245
668	11'-2¾"			12.926			Pe
418	11'-2¾"			13.171			13'-5" Pv
CM	2.1570	Q=65.58	5.76	C=120		0.034979	13'-5" Pf 0.469
418	11'-2¾"			13.171			Pe
412	11'-2¾"			13.641			13'-5" Pv
CM	2.1570	Q=85.44	7.50	C=120		0.057063	13'-5" Pf 0.766
412	11'-2¾"			13.641			Pe
405	11'-2¾"			14.406			13'-5" Pv
CM	2.1570	Q=105.80	9.29	C=120		0.084746	13'-2" Pf 1.116
405	11'-2¾"			14.406			Pe
394	11'-2¾"			15.522			13'-2" Pv
CM	2.1570	Q=126.97	11.15	C=120		0.118747	15'-6¾" Pf 3.748
394	11'-2¾"			15.522			16'-0" Pe 0.533
377	10'-0"			19.803		LtE(3'-8¼), PO(12'-3¾)	31'-6¾" Pv

Pipe Type	Diameter	Flow	Velocity	HWC	Friction Loss	Length	Pressure
Downstream	Elevation	Discharge	K-Factor	Pt	Pn	Eq. Length	Summary
Upstream					Fittings	Total Length	
<b>Route 5</b>							
	1.0490	Q=19.07	7.08	C=120	0.119193	0'-9"	Pf 0.685
D5	11'-11 3/4"	q=19.07	K=5.6	11.600	Spr(-11.600)	5'-0"	Pe 0.325
408	11'-2 3/4"			12.611	PO(5'-0)	5'-9"	Pv
<b>Route 6</b>							
SP	1.0490	Q=19.09	7.09	C=120	0.119372	0'-10 3/4"	Pf 0.704
106	12'-1 1/2"	q=19.09	K=5.6	11.619	Spr(-11.619)	5'-0"	Pe 0.388
401	11'-2 3/4"			12.711	PO(5'-0)	5'-10 3/4"	Pv
<b>Route 7</b>							
SP	1.0490	Q=19.10	7.09	C=120	0.119537	0'-10 3/4"	Pf 0.705
107	12'-1 1/2"	q=19.10	K=5.6	11.636	Spr(-11.636)	5'-0"	Pe 0.388
422	11'-2 3/4"			12.729	PO(5'-0)	5'-10 3/4"	Pv
CM	2.1570	Q=4.90	0.43	C=120	0.000288	13'-5"	Pf 0.004
422	11'-2 3/4"			12.729			Pe
416	11'-2 3/4"			12.733		13'-5"	Pv
CM	2.1570	Q=24.00	2.11	C=120	0.005448	13'-5"	Pf 0.073
416	11'-2 3/4"			12.733			Pe
410	11'-2 3/4"			12.806		13'-5"	Pv
CM	2.1570	Q=43.23	3.80	C=120	0.016179	13'-5"	Pf 0.217
410	11'-2 3/4"			12.806			Pe
403	11'-2 3/4"			13.023		13'-5"	Pv
CM	2.1570	Q=62.56	5.49	C=120	0.032056	13'-2"	Pf 0.422
403	11'-2 3/4"			13.023			Pe
392	11'-2 3/4"			13.445		13'-2"	Pv
CM	2.1570	Q=82.21	7.22	C=120	0.053137	15'-6 3/4"	Pf 1.677
392	11'-2 3/4"			13.445		16'-0"	Pe 0.533
366	10'-0"			15.655	LtE(3'-8 1/4), PO(12'-3 3/4)	31'-6 3/4"	Pv
<b>Route 8</b>							
SP	1.0490	Q=19.11	7.09	C=120	0.119571	0'-10 3/4"	Pf 0.705
108	12'-1 1/2"	q=19.11	K=5.6	11.640	Spr(-11.640)	5'-0"	Pe 0.388
416	11'-2 3/4"			12.733	PO(5'-0)	5'-10 3/4"	Pv
<b>Route 9</b>							
SP	1.0490	Q=19.12	7.10	C=120	0.119715	0'-9"	Pf 0.688
109	11'-11 3/4"	q=19.12	K=5.6	11.655	Spr(-11.655)	5'-0"	Pe 0.325
409	11'-2 3/4"			12.669	PO(5'-0)	5'-9"	Pv
<b>Route 10</b>							
SP	1.0490	Q=19.16	7.11	C=120	0.120168	0'-10 3/4"	Pf 0.708
110	12'-1 1/2"	q=19.16	K=5.6	11.703	Spr(-11.703)	5'-0"	Pe 0.388
402	11'-2 3/4"			12.800	PO(5'-0)	5'-10 3/4"	Pv
<b>Route 11</b>							
SP	1.0490	Q=19.16	7.11	C=120	0.120226	0'-10 3/4"	Pf 0.709
854	12'-1 1/2"	q=19.16	K=5.6	11.709	Spr(-11.709)	5'-0"	Pe 0.388
667	11'-2 3/4"			12.806	PO(5'-0)	5'-10 3/4"	Pv
CM	2.1570	Q=22.84	2.01	C=120	0.004971	13'-5"	Pf 0.067
667	11'-2 3/4"			12.806			Pe
417	11'-2 3/4"			12.873		13'-5"	Pv
CM	2.1570	Q=42.06	3.69	C=120	0.015377	13'-5"	Pf 0.206
417	11'-2 3/4"			12.873			Pe
411	11'-2 3/4"			13.079		13'-5"	Pv
CM	2.1570	Q=61.49	5.40	C=120	0.031052	13'-5"	Pf 0.417
411	11'-2 3/4"			13.079			Pe
404	11'-2 3/4"			13.496		13'-5"	Pv
CM	2.1570	Q=81.18	7.13	C=120	0.051913	13'-2"	Pf 0.684
404	11'-2 3/4"			13.496			Pe
393	11'-2 3/4"			14.179		13'-2"	Pv
CM	2.1570	Q=101.38	8.90	C=120	0.078306	15'-6 3/4"	Pf 2.471
393	11'-2 3/4"			14.179		16'-0"	Pe 0.533
370	10'-0"			17.183	LtE(3'-8 1/4), PO(12'-3 3/4)	31'-6 3/4"	Pv
<b>Route 12</b>							
SP	1.0490	Q=19.21	7.13	C=120	0.120825	0'-10 3/4"	Pf 0.712
111	12'-1 1/2"	q=19.21	K=5.6	11.772	Spr(-11.772)	5'-0"	Pe 0.388
417	11'-2 3/4"			12.873	PO(5'-0)	5'-10 3/4"	Pv
<b>Route 13</b>							
SP	1.0490	Q=19.22	7.14	C=120	0.120956	0'-9"	Pf 0.695
112	11'-11 3/4"	q=19.22	K=5.6	11.786	Spr(-11.786)	5'-0"	Pe 0.325
410	11'-2 3/4"			12.806	PO(5'-0)	5'-9"	Pv
<b>Route 14</b>							
SP	1.0490	Q=19.26	7.15	C=120	0.121309	0'-10 3/4"	Pf 0.715
855	12'-1 1/2"	q=19.26	K=5.6	11.823	Spr(-11.823)	5'-0"	Pe 0.388
668	11'-2 3/4"			12.926	PO(5'-0)	5'-10 3/4"	Pv
<b>Route 15</b>							

# Hydraulic Analysis

Job Number: 2440 CAGES  
Report Description: Ordinary Group I

Pipe Type	Diameter	Flow	Velocity	HWC	Friction Loss	Length	Pressure
Downstream	Elevation	Discharge	K-Factor	Pt	Pn	Eq. Length	Summary
Upstream						Total Length	
SP	1.0490	Q=19.29	7.16	C=120	0.121661	0'-10%	Pf 0.717
113	12'-1½	q=19.29	K=5.6	11.860	Spr(-11.860)	5'-0"	Pe 0.388
90	11'-2¾			12.966	PO(5'-0)	5'-10¾"	Pv
Route 16							
SP	1.0490	Q=19.33	7.18	C=120	0.122180	0'-10%	Pf 0.720
114	12'-1½	q=19.33	K=5.6	11.915	Spr(-11.915)	5'-0"	Pe 0.388
403	11'-2¾			13.023	PO(5'-0)	5'-10¾"	Pv
Route 17							
SP	1.0490	Q=19.39	7.20	C=120	0.122868	0'-10%	Pf 0.724
115	12'-1½	q=19.39	K=5.6	11.987	Spr(-11.987)	5'-0"	Pe 0.388
391	11'-2¾			13.100	PO(5'-0)	5'-10¾"	Pv
Route 18							
SP	1.0490	Q=19.43	7.21	C=120	0.123408	0'-9"	Pf 0.710
116	11'-11¼	q=19.43	K=5.6	12.044	Spr(-12.044)	5'-0"	Pe 0.325
411	11'-2¾			13.079	PO(5'-0)	5'-9"	Pv
Route 19							
SP	1.0490	Q=19.44	7.22	C=120	0.123509	0'-10%	Pf 0.728
117	12'-1½	q=19.44	K=5.6	12.055	Spr(-12.055)	5'-0"	Pe 0.388
418	11'-2¾			13.171	PO(5'-0)	5'-10¾"	Pv
Route 20							
SP	1.0490	Q=19.65	7.30	C=120	0.125967	0'-10%	Pf 0.743
118	12'-1½	q=19.65	K=5.6	12.314	Spr(-12.314)	5'-0"	Pe 0.388
392	11'-2¾			13.445	PO(5'-0)	5'-10¾"	Pv
Route 21							
SP	1.0490	Q=19.69	7.31	C=120	0.126416	0'-10%	Pf 0.745
120	12'-1½	q=19.69	K=5.6	12.362	Spr(-12.362)	5'-0"	Pe 0.388
404	11'-2¾			13.496	PO(5'-0)	5'-10¾"	Pv
Route 22							
SP	1.0490	Q=19.86	7.37	C=120	0.128449	0'-9"	Pf 0.739
122	11'-11¼	q=19.86	K=5.6	12.577	Spr(-12.577)	5'-0"	Pe 0.325
412	11'-2¾			13.641	PO(5'-0)	5'-9"	Pv
Route 23							
SP	1.0490	Q=20.20	7.50	C=120	0.132529	0'-10%	Pf 0.781
133	12'-1½	q=20.20	K=5.6	13.009	Spr(-13.009)	5'-0"	Pe 0.388
393	11'-2¾			14.179	PO(5'-0)	5'-10¾"	Pv
Route 24							
SP	1.0490	Q=20.36	7.56	C=120	0.134556	0'-10%	Pf 0.793
134	12'-1½	q=20.36	K=5.6	13.225	Spr(-13.225)	5'-0"	Pe 0.388
405	11'-2¾			14.406	PO(5'-0)	5'-10¾"	Pv
Route 25							
SP	1.0490	Q=21.16	7.86	C=120	0.144478	0'-10%	Pf 0.852
135	12'-1½	q=21.16	K=5.6	14.282	Spr(-14.282)	5'-0"	Pe 0.388
394	11'-2¾			15.522	PO(5'-0)	5'-10¾"	Pv
Route 26							
CM	4.2600	Q=112.23	2.53	C=120	0.003437	4'-4¾"	Pf 0.106
123	18'-3"			21.259		26'-4"	Pe 0.253
262	17'-8"			21.617	T(26'-4)	30'-8¾"	Pv
CM	6.3570	Q=112.23	1.13	C=120	0.000489	2'-8"	Pf 0.020
262	17'-8"			21.617		37'-8¾"	Pe 1.156
261	15'-0"			22.793	T(37'-8¾)	40'-4¾"	Pv
Route 27							
CM	2.6350	Q=7.70	0.45	C=120	0.000251	0'-11"	Pf 0.000
480	10'-7¾"			23.622			Pe 0.000
482	10'-7¾"			23.622		0'-11"	Pv
CM	3.2600	Q=7.70	0.30	C=120	0.000089	4'-4¾"	Pf 0.003
482	10'-7¾"			23.622		26'-10½"	Pe -1.888
297	15'-0"			21.737	LIE(6'-8¾), PO(20'-2)	31'-2¾"	Pv
Route 28							
UG	7.9800	Q=165.30	1.06	C=150	0.000219	1167'-0"	Pf 0.285
3	-5'-0"			32.657		134'-3¾"	Pe
5	-5'-0"			32.942	2E(27'-2), 2EE(13'-7), T(52'-9¾)	1301'-3¾"	Pv
Route 29							
CM	4.2600	Q=112.23	2.53	C=120	0.003437	171'-11"	Pf 1.007
313	15'-0"			21.348		121'-1¾"	Pe -1.409
132	18'-3"			20.947	2LIE(7'-10¾), 4T(26'-4)	293'-0½"	Pv
CM	4.2600	Q=112.23	2.53	C=120	0.003437	10'-0"	Pf 0.034
132	18'-3"			20.947			Pe
131	18'-3"			20.981		10'-0"	Pv
CM	4.2600	Q=112.23	2.53	C=120	0.003437	10'-0"	Pf 0.034
131	18'-3"			20.981			Pe
130	18'-3"			21.015		10'-0"	Pv

# Hydraulic Analysis

Job Number: 2440 CAGES  
Report Description: Ordinary Group I

Pipe Type	Diameter	Flow	Velocity	HWC	Friction Loss	Length	Pressure
Downstream	Elevation	Discharge	K-Factor	Pt	Pn	Eq. Length	Summary
Upstream						Total Length	
CM	4.2600	Q=112.23	2.53	C=120	0.003437	10'-0"	Pf 0.034
130	18'-3"			21.015			Pe
29	18'-3"			21.050		10'-0"	Pv
CM	4.2600	Q=112.23	2.53	C=120	0.003437	10'-0"	Pf 0.034
129	18'-3"			21.050			Pe
128	18'-3"			21.084		10'-0"	Pv
CM	4.2600	Q=112.23	2.53	C=120	0.003437	10'-0"	Pf 0.034
128	18'-3"			21.084			Pe
127	18'-3"			21.118		10'-0"	Pv
CM	4.2600	Q=112.23	2.53	C=120	0.003437	10'-0"	Pf 0.034
127	18'-3"			21.118			Pe
126	18'-3"			21.153		10'-0"	Pv
CM	4.2600	Q=112.23	2.53	C=120	0.003437	10'-0"	Pf 0.034
126	18'-3"			21.153			Pe
125	18'-3"			21.187		10'-0"	Pv
CM	4.2600	Q=112.23	2.53	C=120	0.003437	10'-0"	Pf 0.034
125	18'-3"			21.187			Pe
124	18'-3"			21.222		10'-0"	Pv
CM	4.2600	Q=112.23	2.53	C=120	0.003437	10'-10"	Pf 0.037
124	18'-3"			21.222			Pe
123	18'-3"			21.259		10'-10"	Pv
***** Route 30 *****							
CM	2.6350	Q=7.94	0.47	C=120	0.000265	9'-3"	Pf 0.002
678	10'-0"			13.296			Pe
674	10'-0"			13.299		9'-3"	Pv
***** Route 31 *****							
CM	2.1570	Q=3.68	0.32	C=120	0.000170	4'-11 1/4"	Pf 0.004
685	10'-0"			13.335	PO(12'-3 1/4")	16'-0"	Pe -0.533
667	11'-2 3/4"			12.806	LIE(3'-8 1/4")	20'-11 1/4"	Pv
***** Route 32 *****							
CM	2.1570	Q=14.21	1.25	C=120	0.002065	4'-11 1/4"	Pf 0.043
422	11'-2 3/4"			12.729		16'-0"	Pe 0.533
681	10'-0"			13.306	LIE(3'-8 1/4"), PO(12'-3 1/4")	20'-11 1/4"	Pv
***** Route 33 *****							
CM	2.1570	Q=5.25	0.46	C=120	0.000327	13'-5"	Pf 0.004
415	11'-2 3/4"			12.642			Pe
421	11'-2 3/4"			12.647		13'-5"	Pv
***** Route 34 *****							
CM	2.1570	Q=9.57	0.84	C=120	0.000994	13'-5"	Pf 0.013
414	11'-2 3/4"			12.598			Pe
420	11'-2 3/4"			12.611		13'-5"	Pv
***** Route 35 *****							
BL	1.0490	Q=8.88	3.30	C=120	0.029005	20'-0"	Pf 0.870
479	7'-10"			24.556		10'-0"	Pe -0.217
358	8'-4"			25.209	T(5'-0"), PO(5'-0")	30'-0"	Pv
CM	2.6350	Q=8.88	0.52	C=120	0.000327	8'-1 1/4"	Pf 0.010
358	8'-4"			25.209		21'-11 1/2"	Pe -2.890
198	15'-0"			22.329	LIE(5'-6"), PO(16'-5 1/4")	30'-1 1/4"	Pv
***** Route 36 *****							
BL	1.0490	Q=7.70	2.86	C=120	0.022264	2'-9 3/4"	Pf 0.285
479	7'-10"			24.556	T(5'-0")	10'-0"	Pe -1.219
480	10'-7 3/4"			23.622	PO(5'-0")	12'-9 3/4"	Pv
***** Route 37 *****							
BL	1.0490	Q=16.59	6.16	C=120	0.092043	15'-6"	Pf 2.071
530	10'-0"			21.546	PO(5'-0")	7'-0"	Pe 0.939
479	7'-10"			24.556	E(2'-0")	22'-6"	Pv

### Equivalent Pipe Lengths of Valves and Fittings (C=120 only)

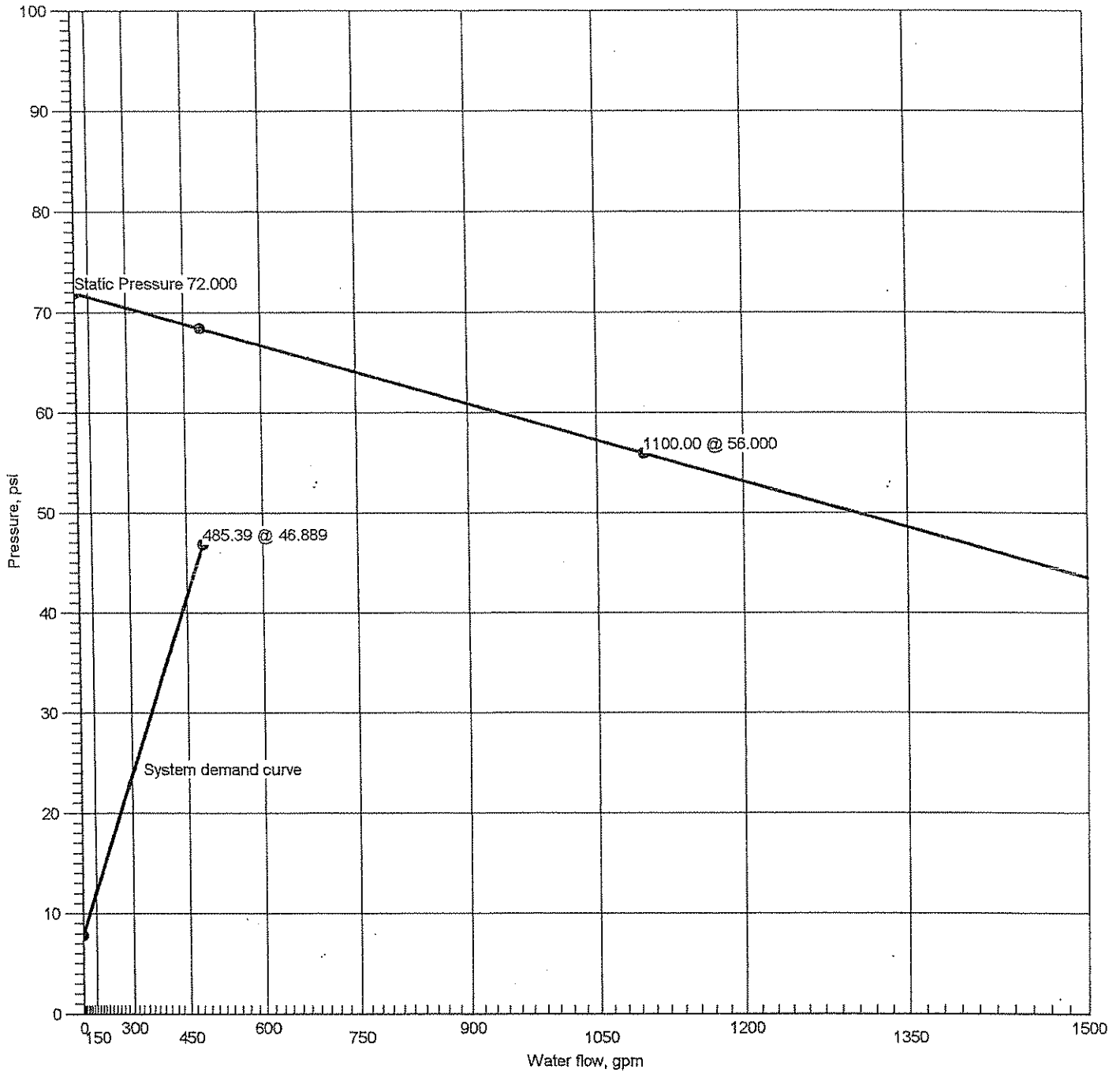
### Value Multiplier

$$\left( \frac{\text{Actual Inside Diameter}}{\text{Schedule 40 Steel Pipe Inside Diameter}} \right)^{4.87} = \text{Factor}$$

Value Of C	100	130	140	150
Multiplying Factor	0.713	1.16	1.33	1.51

Pipe Type	Diameter	Flow	Velocity	HWC	Friction Loss		Length	Pressure	
Downstream	Elevation	Discharge	K-Factor	Pt	Pn	Fittings	Eq. Length	Summary	
Upstream							Total Length		
<b>Pipe Type Legend</b>		<b>Units Legend</b>				<b>Fittings Legend</b>			
AO	Arm-Over	Diameter	Inch				ALV	Alarm Valve	
.L	Branch Line	Elevation	Foot				AngV	Angle Valve	
CM	Cross Main	Flow	gpm				b	Bushing	
DN	Drain	Discharge	gpm				BalV	Ball Valve	
DR	Drop	Velocity	fps				BFP	Backflow Preventer	
DY	Dynamic	Pressure	psi				BV	Butterfly Valve	
FM	Feed Main	Length	Foot				C	Cross Flow Turn 90°	
FR	Feed Riser	Friction Loss	psi/Foot				cplg	Coupling	
MS	Miscellaneous	HWC	Hazen-Williams Constant				Cr	Cross Run	
OR	Outtrigger	Pt	Total pressure at a point in a pipe				CV	Check Valve	
RN	Riser Nipple	Pn	Normal pressure at a point in a pipe				DelV	Deluge Valve	
SP	Sprig	Pf	Pressure loss due to friction between points				DPV	Dry Pipe Valve	
ST	Stand Pipe	Pe	Pressure due to elevation difference between indicated points				E	90° Elbow	
UG	Underground	Pv	Velocity pressure at a point in a pipe				EE	45° Elbow	
							Ee1	11¼° Elbow	
							Ee2	22½° Elbow	
							f	Flow Device	
							FDC	Fire Department Connection	
							fE	90° FireLock(TM) Elbow	
							fEE	45° FireLock(TM) Elbow	
							flg	Flange	
							FN	Floating Node	
							FT	FireLock(TM) Tee	
							g	Gauge	
							GloV	Globe Valve	
							GV	Gate Valve	
							Hose	Hose	
							HV	Hose Valve	
							Hyd	Hydrant	
							LtE	Long Turn Elbow	
							mecT	Mechanical Tee	
							Noz	Nozzle	
							P1	Pump In	
							P2	Pump Out	
							PIV	Post Indicating Valve	
							PO	Pipe Outlet	
							PrV	Pressure Relief Valve	
							PRV	Pressure Reducing Valve	
							red	Reducer/Adapter	
							S	Supply	
							sCV	Swing Check Valve	
							Spr	Sprinkler	
							St	Strainer	
							T	Tee Flow Turn 90°	
							Tr	Tee Run	
							U	Union	
							WirF	Wirsbo	
							WMV	Water Meter Valve	
							Z	Cap	

### Supply at Node 1



Hydraulic Graph

Supply at Node 1

Static Pressure  
72.000

Residual Pressure  
1100.00 @ 56.000

Available Pressure/Time of Test  
68.478 @ 485.39

System Demand  
485.39 @ 46.889

System Demand (Including Hose Allowance)  
485.39 @ 46.889



# Hydraulic Overview

Job Number: 2440 ARMORY  
Report Description: Ordinary Group I

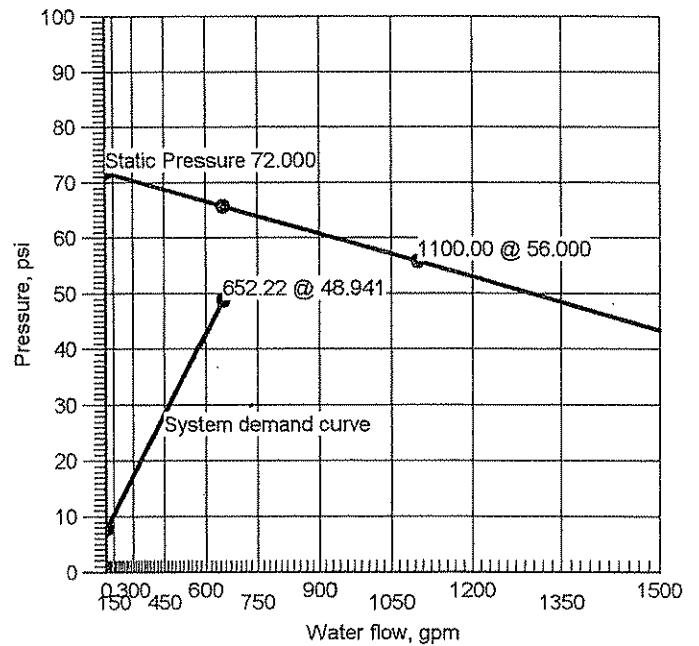
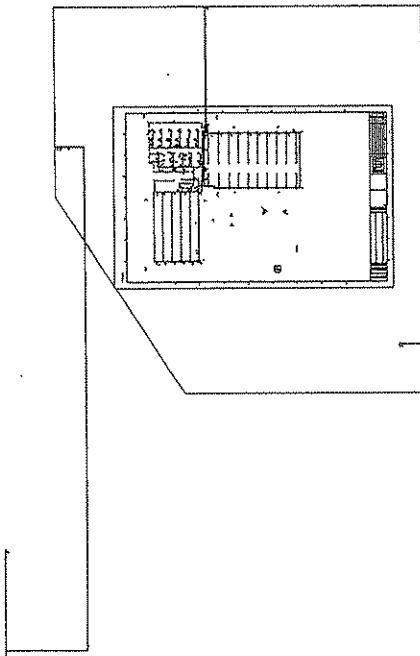
Job			
Job Number 2440 ARMORY		Design Engineer	
Job Name STENNIS RIVERINE BLDG 2440 ARMORY & MISC		Phone	FAX
Address 1 OPERATIONS BLDG		State Certification/License Number	
Address 2 STENNIS SPACE CENTER		AHJ	
City STENNIS	State MS	Zip Code	Job Site

System	
Density 0.150gpm/ft <sup>2</sup>	Area of Application 3000.00ft <sup>2</sup> (Actual 3009.76ft <sup>2</sup> )
Most Demanding Sprinkler Data 5.6 K-Factor 19.00 at 11.511	Hose Streams 0.00
Coverage Per Sprinkler 100.00ft <sup>2</sup>	Number Of Sprinklers Calculated 34
System Pressure Demand 48.941	System Flow Demand 652.22
Total Demand 652.22 @ 48.941	Pressure Result +16.975 (25.8%)

Supplies					Check Point Gauges			
Node	Flow(gpm)	Hose Flow(gpm)	Static(psi)	Residual(psi)	Identifier	Pressure(psi)	K-Factor(K)	Flow(gpm)
1	1100.00	0.00	72.000	56.000				

RP-3 BLDG 2440 2441 1st Floor R5

Supply at Node 1 (1100.00, 0.00, 72.000, 56.000)



# Hydraulic Summary

Job Number: 2440 ARMORY  
Report Description: Ordinary Group I

<b>Job</b>			
Job Number 2440 ARMORY		Design Engineer	
Job Name STENNIS RIVERINE BLDG 2440 ARMORY & MISC		State Certification/License Number	
Address 1 OPERATIONS BLDG		AHJ	
Address 2 STENNIS SPACE CENTER		Job Site	
City STENNIS	State MS	Zip Code	Drawing Name FP-3 BLDG 2440 2441 1st Floor R5
<b>System</b>		<b>Remote Area(s)</b>	
Most Demanding Sprinkler Data 5.6 K-Factor 19.00 at 11.511		Occupancy Ordinary Group I	
Hose Allowance At Source 0.00		Density 0.150gpm/ft <sup>2</sup>	Area of Application 3000.00ft <sup>2</sup> (Actual 3009.76ft <sup>2</sup> )
Additional Hose Supplies		Number Of Sprinklers Calculated 34	Coverage Per Sprinkler 100.00ft <sup>2</sup>
Node		Flow(gpm)	
AutoPeak Results: Pressure For Remote Area(s) Adjacent To Most Remote Area			
Total Hose Streams 0.00			
System Flow Demand 652.22		Total Water Required (Including Hose Allowance) 652.22	
Maximum Pressure Unbalance In Loops 0.000			
Maximum Velocity Above Ground 19.87 between nodes 480 and 295			
Maximum Velocity Under Ground 4.18 between nodes 1 and 12			
Volume capacity of Wet Pipes 6939.58gal		Volume capacity of Dry Pipes	

**Supplies**

Node	Hose Flow (gpm)	Static (psi)	Residual (psi)	@	Flow (gpm)	Available (psi)	@	Total Demand (gpm)	Required (psi)	Safety Margin (psi)
1	0.00	72.000	56.000		1100.00	65.916		652.22	48.941	16.975

**Contractor**

Contractor Number		Contact Name		Contact Title
Contractor Name SIMPLEXGRINNELL		Phone		Extension
Address 1 5800 JEFFERSON HWY		FAX		
Address 2 SUITE A		E-mail		
City HARAHAN	State LA	Zip Code 70123	Web Site	

# Summary Of Outflowing Devices

Job Number: 2440 ARMORY  
Report Description: Ordinary Group I

Device		Actual Flow (gpm)	Minimum Flow (gpm)	K-Factor (K)	Pressure (psi)		
⇒ Sprinkler	203	19.00	19.00	5.6	11.511		
Sprinkler	204	19.08	19.00	5.6	11.610		
Sprinkler	207	19.37	19.00	5.6	11.958		
Sprinkler	213	19.94	19.00	5.6	12.684		
Sprinkler	220	20.86	19.00	5.6	13.877		
Sprinkler	235	21.44	19.00	5.6	14.659		
Sprinkler	206	19.32	19.00	5.6	11.904		
Sprinkler	208	19.40	19.00	5.6	12.006		
Sprinkler	211	19.69	19.00	5.6	12.366		
Sprinkler	215	20.28	19.00	5.6	13.114		
Sprinkler	223	21.21	19.00	5.6	14.345		
Sprinkler	228	21.80	19.00	5.6	15.150		
Sprinkler	212	15.56	14.82	5.6	7.721		
Sprinkler	201	15.53	14.82	5.6	7.688		
Sprinkler	202	15.64	14.82	5.6	7.799		
Sprinkler	205	15.13	14.82	5.6	7.297		
Sprinkler	209	15.41	14.82	5.6	7.569		
Sprinkler	218	18.37	14.82	5.6	10.756		
Sprinkler	226	19.35	14.82	5.6	11.938		
Sprinkler	219	16.90	14.82	5.6	9.106		
Sprinkler	216	17.77	14.82	5.6	10.072		
Sprinkler	221	18.76	14.82	5.6	11.219		
Sprinkler	210	15.61	14.82	5.6	7.769		
Sprinkler	214	16.09	14.82	5.6	8.252		
Sprinkler	237	18.79	14.82	5.6	11.256		
Sprinkler	227	19.79	14.82	5.6	12.490		
Sprinkler	229	20.22	14.82	5.6	13.031		
Sprinkler	231	21.28	14.82	5.6	14.446		
Sprinkler	217	18.18	14.82	5.6	10.545		
Sprinkler	224	19.01	14.82	5.6	11.520		
Sprinkler	239	20.43	14.82	5.6	13.307		
Sprinkler	232	23.85	14.82	5.6	18.143		
Sprinkler	233	24.58	14.82	5.6	19.271		
Sprinkler	234	24.59	14.82	5.6	19.281		

⇒ Most Demanding Sprinkler Data

# Node Analysis

Job Number: 2440 ARMORY  
Report Description: Ordinary Group I

Node	Elevation(foot)	Fittings	Pressure(psi)	Discharge(gpm)
3	-5'-0	T(59'-4½)	33.402	
37	10'-0	PO(5'-0)	12.782	
38	10'-0	PO(5'-0)	12.886	
39	10'-0	PO(5'-0)	13.255	
40	10'-0	PO(5'-0)	14.023	
41	10'-0	PO(5'-0)	15.287	
42	10'-0	PO(5'-0)	16.113	
7	1'-0		30.244	
84	4'-0¾	CV(16'-0)	28.748	
161	8'-3		26.023	
163	15'-0	LtE(11'-3¾)	23.011	
261	15'-0	T(37'-8¾)	22.669	
262	17'-8		21.494	
123	18'-3	PO(12'-3¾)	21.141	
124	18'-3	PO(12'-3¾)	21.106	
125	18'-3	PO(12'-3¾)	21.074	
126	18'-3	PO(12'-3¾)	21.041	
127	18'-3	PO(12'-3¾)	21.008	
128	18'-3	PO(12'-3¾)	20.976	
129	18'-3	PO(12'-3¾)	20.943	
130	18'-3	PO(12'-3¾)	20.911	
131	18'-3	PO(12'-3¾)	20.878	
132	18'-3	PO(12'-3¾)	20.845	
284	15'-0		22.669	
165	10'-0	PO(5'-0)	13.198	
167	10'-0	PO(5'-0)	13.306	
169	10'-0	PO(5'-0)	13.686	
171	10'-0	PO(5'-0)	14.478	
172	10'-0	PO(5'-0)	15.781	
174	10'-0	PO(5'-0)	16.634	
5	-5'-0	2T(52'-9¾)	33.894	
11	-5'-0	LtE(19'-7½)	33.954	
12	-6'-0	LtE(22'-0¾)	46.592	
164	8'-4	PO(6'-0)	15.821	
190	10'-0	E(3'-0)	13.882	
166	8'-4	PO(6'-0)	15.944	
191	10'-0	E(3'-0)	13.996	
168	8'-4	PO(6'-0)	16.377	
192	10'-0	E(3'-0)	14.395	
170	8'-4	PO(6'-0)	17.279	
193	10'-0	E(3'-0)	15.227	
194	8'-4		18.697	
173	8'-4	PO(6'-0)	18.762	
195	10'-0	E(3'-0)	16.595	
175	8'-4	PO(6'-0)	19.732	
196	10'-0	E(3'-0)	17.490	
358	8'-4	PO(5'-0)	20.516	
198	15'-0	PO(16'-5¾)	21.740	
222	11'-2¾	2T(5'-0)	9.782	
225	11'-2¾	2T(5'-0)	8.995	
230	11'-2¾	T(5'-0)	9.818	
236	11'-2¾	T(5'-0)	10.419	
238	11'-2¾	T(5'-0)	11.704	
242	11'-2¾	T(5'-0)	9.547	
245	11'-2¾	T(5'-0)	12.063	
248	11'-2¾	T(5'-0)	13.432	
251	11'-2¾	T(5'-0)	9.586	
273	11'-2¾	T(5'-0)	14.033	
276	11'-2¾	T(5'-0)	15.601	
278	11'-2¾	T(8'-0), T(5'-0)	11.268	
280	11'-2¾	T(5'-0), T(6'-0)	12.723	
282	11'-2¾	2T(6'-0)	13.982	
289	10'-7¾	PO(8'-0)	14.372	
290	10'-7¾	PO(8'-0)	15.137	
478	10'-7¾	T(12'-3¾)	16.385	
293	10'-7¾	PO(8'-0)	16.461	
294	10'-7¾	PO(6'-0)	17.596	
295	10'-7¾	PO(6'-0)	19.498	
479	7'-10	T(5'-0)	21.699	
480	10'-7¾	PO(5'-0)	20.068	
482	10'-7¾		20.306	
297	15'-0	PO(20'-2)	21.298	
303	11'-2¾	E(2'-0)	13.635	
530	10'-0	PO(5'-0)	23.370	
313	15'-0	T(26'-4)	21.299	
360	10'-0	2PO(16'-5¾)	23.269	
362	10'-0	2PO(16'-5¾)	23.269	



**STENNIS RIVERINE & COMBATANT TRAINING**  
**FACILITY**  
**STENNIS SPACE CENTER**  
**STENNIS, MS 39529**

**FIRE PROTECTION/ SPRINKLER SYSTEMS**  
**OPERATIONS BUILDING 2440/2441**  
**BOAT STORAGE BUILDING 2442**

## **SECTION 6**

# **HYDRAULIC CALCULATIONS WITH HOSE ALLOWANCE FOR REFERENCE ONLY**

**SIMPLEXGRINNELL**  
**5800 JEFFERSON HWY, SUITE A**  
**HARAHAN, LA 70123**  
**PHONE: 504-736-0104**  
**FAX: 504-736-9292**



# Hydraulic Overview

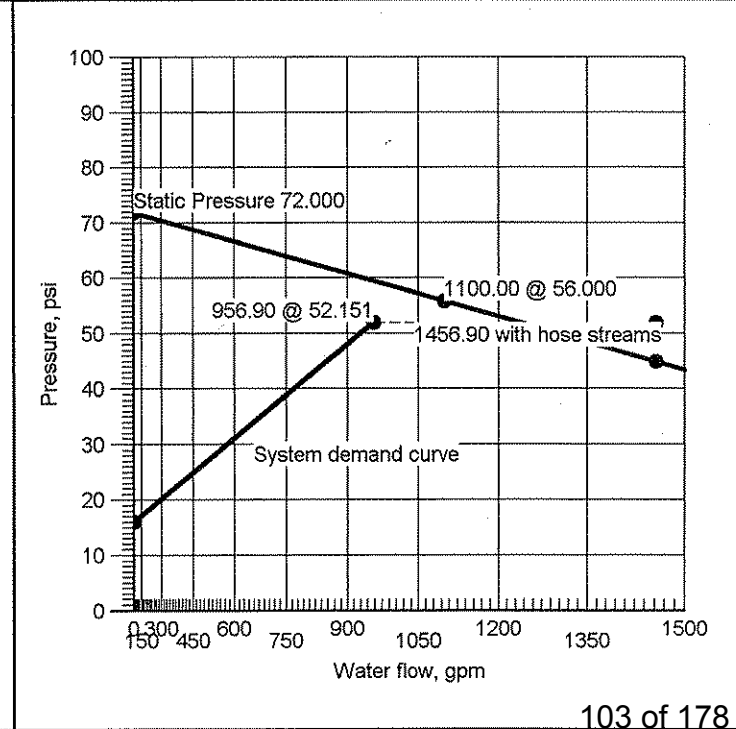
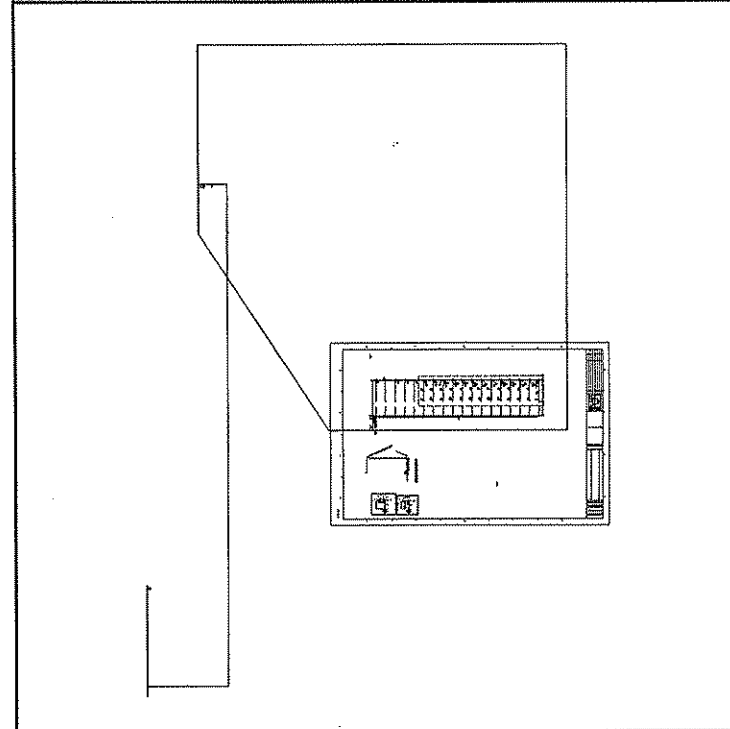
Job Number: 269-941989101 R1  
Report Description: Ordinary Group II

<b>Job</b>			<b>Design Engineer</b>		
Job Number 269-941989101 R1			Phone		
Job Name STENNIS RIVERINE BLDG 2442 BOAT STORAGE			FAX		
Address 1 BOAT STORAGE BLDG			State Certification/License Number		
Address 2 STENNIS SPACE CENTER			AHJ		
City STENNIS	State MS	Zip Code	Job Site DEMAND WITH 500 GPM HOSE ALLOWANCE		

<b>System</b>	
Density 0.200gpm/ft <sup>2</sup>	Area of Application 3900.00ft <sup>2</sup> (Actual 3927.08ft <sup>2</sup> )
Most Demanding Sprinkler Data 8 K-Factor 21.17 at 7.000	Hose Streams 500.00
Coverage Per Sprinkler 100.00ft <sup>2</sup>	Number Of Sprinklers Calculated 39
System Pressure Demand 52.151	System Flow Demand 956.90
Total Demand 1456.90 @ 52.151	Pressure Result -7.059 (-13.5%)

<b>Supplies</b>					<b>Check Point Gauges</b>			
Node	Flow(gpm)	Hose Flow(gpm)	Static(psi)	Residual(psi)	Identifier	Pressure(psi)	K-Factor(K)	Flow(gpm)
1	1100.00	500.00	72.000	56.000	BOR	0.000	0	0.00
					BOR	0.000	0	0.00

FP-2:BLDG 2442.R5 Supply at Node 1 (1100.00, 500.00, 72.000, 56.000)





# Summary Of Outflowing Devices

Job Number: 269-941989101 R1  
 Report Description: Ordinary Group II

Device		Actual Flow (gpm)	Minimum Flow (gpm)	K-Factor (K)	Pressure (psi)		
Sprinkler	139	28.51	20.25	8	12.703		
Sprinkler	136	28.38	20.25	8	12.587		
Sprinkler	133	28.17	20.25	8	12.401		
Sprinkler	130	27.61	20.25	8	11.908		
Sprinkler	127	27.18	20.25	8	11.544		
Sprinkler	124	26.88	20.25	8	11.290		
Sprinkler	606	26.66	20.25	8	11.109		
Sprinkler	607	26.55	20.25	8	11.016		
Sprinkler	608	26.52	20.25	8	10.991		
Sprinkler	106	26.51	20.25	8	10.982		
Sprinkler	103	26.49	20.25	8	10.966		
Sprinkler	109	26.52	20.25	8	10.985		
Sprinkler	609	26.61	20.25	8	11.060		
Sprinkler	138	26.06	20.25	8	10.609		
Sprinkler	135	25.92	20.25	8	10.496		
Sprinkler	132	25.69	20.25	8	10.314		
Sprinkler	129	25.08	20.25	8	9.832		
Sprinkler	126	24.63	20.25	8	9.476		
Sprinkler	123	24.30	20.25	8	9.228		
Sprinkler	615	24.07	20.25	8	9.051		
Sprinkler	616	23.95	20.25	8	8.960		
Sprinkler	111	23.91	20.25	8	8.935		
Sprinkler	105	23.90	20.25	8	8.926		
Sprinkler	102	23.88	20.25	8	8.911		
Sprinkler	108	23.91	20.25	8	8.929		
Sprinkler	617	24.00	20.25	8	9.003		
Sprinkler	137	23.58	20.25	8	8.688		
Sprinkler	134	23.43	20.25	8	8.575		
Sprinkler	131	23.18	20.25	8	8.394		
Sprinkler	128	22.51	20.25	8	7.915		
Sprinkler	125	22.00	20.25	8	7.562		
Sprinkler	623	21.64	20.25	8	7.315		
Sprinkler	624	21.37	20.25	8	7.139		
Sprinkler	625	21.24	20.25	8	7.048		
Sprinkler	110	21.20	20.25	8	7.024		
Sprinkler	104	21.19	20.25	8	7.015		
⇒ Sprinkler	101	21.17	20.25	8	7.000		
Sprinkler	107	21.19	20.25	8	7.018		
Sprinkler	626	21.30	20.25	8	7.092		

⇒ Most Demanding Sprinkler Data

# Node Analysis

Job Number: 269-941989101 R1  
Report Description: Ordinary Group II

Node	Elevation(Foot)	Fittings	Pressure(psi)	Discharge(gpm)
5	-5'-0	2T(52'-9%)	34.411	
7	-5'-0	LIE(19'-7½)	34.532	
9	-6'-0	LIE(22'-0%)	47.383	
93	19'-2		14.301	
94	19'-2		13.790	
95	19'-2		13.414	
96	19'-2		13.151	
99	19'-2		12.842	
100	19'-2		12.832	
155	19'-2		12.913	
158	18'-9¼	PO(12'-3¾)	16.182	
159	18'-9¼	PO(12'-3¾)	16.027	
160	18'-9¼	PO(12'-3¾)	15.871	
161	18'-9¼	PO(12'-3¾)	15.715	
162	18'-9¼	PO(12'-3¾)	15.560	
147	18'-9¼	PO(12'-3¾)	15.404	
148	18'-9¼	PO(12'-3¾)	15.278	
146	18'-9¼		15.201	
112	18'-9¼	PO(12'-3¾)	15.055	
113	18'-9¼	PO(12'-3¾)	14.519	
114	18'-9¼	PO(12'-3¾)	14.124	
115	18'-9¼	PO(12'-3¾)	13.848	
116	18'-9¼	PO(12'-3¾)	13.670	
117	18'-9¼	PO(12'-3¾)	13.568	
118	18'-9¼	PO(12'-3¾)	13.524	
119	18'-9¼	PO(12'-3¾)	13.513	
120	18'-9¼	PO(12'-3¾)	13.514	
121	18'-9¼	PO(12'-3¾)	13.535	
122	18'-9¼	PO(12'-3¾)	13.599	
316	18'-9¼	C(26'-4), C(37'-8¾)	17.392	
14	1'-0		30.209	
332	3'-3	BV(12'-7)	29.173	
338	18'-9¼	LIE(11'-3¾)	17.727	
16	-5'-0	T(59'-4½)	33.358	
454	-4'-10		0.000	
139	22'-7¾	Spr(-12.703)	12.703	28.51
136	22'-7¾	Spr(-12.587)	12.587	28.38
133	22'-7¾	Spr(-12.401)	12.401	28.17
130	22'-7¾	Spr(-11.908)	11.908	27.61
127	22'-7¾	Spr(-11.544)	11.544	27.18
124	22'-7¾	Spr(-11.290)	11.290	26.88
606	22'-7¾	Spr(-11.109)	11.109	26.66
607	22'-7¾	Spr(-11.016)	11.016	26.55
608	22'-7¾	Spr(-10.991)	10.991	26.52
106	22'-7¾	Spr(-10.982)	10.982	26.51
103	22'-7¾	Spr(-10.966)	10.966	26.49
109	22'-7¾	Spr(-10.985)	10.985	26.52
609	22'-7¾	Spr(-11.060)	11.060	26.61
138	26'-11¼	Spr(-10.609)	10.609	26.06
135	26'-11¼	Spr(-10.496)	10.496	25.92
132	26'-11¼	Spr(-10.314)	10.314	25.69
129	26'-11¼	Spr(-9.832)	9.832	25.08
126	26'-11¼	Spr(-9.476)	9.476	24.63
123	26'-11¼	Spr(-9.228)	9.228	24.30
615	26'-11¼	Spr(-9.051)	9.051	24.07
616	26'-11¼	Spr(-8.960)	8.960	23.95
111	26'-11¼	Spr(-8.935)	8.935	23.91
105	26'-11¼	Spr(-8.926)	8.926	23.90
102	26'-11¼	Spr(-8.911)	8.911	23.88
108	26'-11¼	Spr(-8.929)	8.929	23.91
617	26'-11¼	Spr(-9.003)	9.003	24.00
137	31'-3	Spr(-8.688)	8.688	23.58
134	31'-3	Spr(-8.575)	8.575	23.43
131	31'-3	Spr(-8.394)	8.394	23.18
128	31'-3	Spr(-7.915)	7.915	22.51
125	31'-3	Spr(-7.562)	7.562	22.00
623	31'-3	Spr(-7.315)	7.315	21.64
624	31'-3	Spr(-7.139)	7.139	21.37
625	31'-3	Spr(-7.048)	7.048	21.24
110	31'-3	Spr(-7.024)	7.024	21.20
104	31'-3	Spr(-7.015)	7.015	21.19
101	31'-3	Spr(-7.000)	7.000	21.17
107	31'-3	Spr(-7.018)	7.018	21.19
626	31'-3	Spr(-7.092)	7.092	21.30
1	-6'-0	S	52.151	956.90

# Hydraulic Analysis

Job Number: 269-941989101 R1  
Report Description: Ordinary Group II

Pipe Type	Diameter	Flow	Velocity	HWC	Friction Loss	Length	Pressure
Downstream	Elevation	Discharge	K-Factor	Pt	Pn	Eq. Length	Summary
Upstream						Total Length	
<b>Route 1</b>							
CM	2.1570	Q=21.17	1.86	C=120	0.004318	11'-0"	Pf 0.047
101	31'-3"	q=21.17	K=8	7.000	Spr(-7.000)		Pe 1.863
102	26'-11 1/4"			8.911		11'-0"	Pv
CM	2.1570	Q=45.05	3.96	C=120	0.017461	11'-0"	Pf 0.192
102	26'-11 1/4"	q=23.88	K=8	8.911	Spr(-8.911)		Pe 1.863
103	22'-7 3/4"			10.966		11'-0"	Pv
CM	2.1570	Q=71.54	6.28	C=120	0.041087	5'-0 1/2"	Pf 0.865
103	22'-7 3/4"	q=26.49	K=8	10.966	Spr(-10.966)	16'-0"	Pe 1.683
120	18'-9 1/4"			13.514	LtE(3'-8 3/4"), PO(12'-3 3/4")	21'-0 1/2"	Pv
CM	4.2600	Q=85.19	1.92	C=120	0.002064	10'-0"	Pf 0.021
120	18'-9 1/4"			13.514			Pe 0.000
121	18'-9 1/4"			13.535		10'-0"	Pv
CM	4.2600	Q=156.81	3.53	C=120	0.006381	10'-0"	Pf 0.064
121	18'-9 1/4"			13.535			Pe -0.000
122	18'-9 1/4"			13.599		10'-0"	Pv
CM	4.2600	Q=228.72	5.15	C=120	0.012828	216'-8 1/2"	Pf 3.793
122	18'-9 1/4"			13.599		79'-0"	Pe -0.000
316	18'-9 1/4"			17.392	2T(26'-4), C(26'-4)	295'-8 1/2"	Pv
CM	6.3570	Q=956.90	9.67	C=120	0.025788	1'-8"	Pf 0.335
316	18'-9 1/4"			17.392		11'-3 3/4"	Pe -0.000
338	18'-9 1/4"			17.727	LtE(11'-3 3/4")	13'-0"	Pv
FR	6.3570	Q=956.90	9.67	C=120	0.025788	13'-8 1/4"	Pf 4.715
338	18'-9 1/4"			17.727		52'-9 3/4"	Pe 6.731
332	3'-3"			29.173	f(-3.000), CV(40'-2 1/4"), BV(12'-7")	66'-6"	Pv
FR	6.0650	Q=956.90	10.63	C=120	0.032424	2'-0"	Pf 0.065
332	3'-3"			29.173			Pe 0.971
14	1'-0"			30.209		2'-0"	Pv
UG	8.3900	Q=956.90	5.55	C=140	0.005020	19'-3 1/2"	Pf 0.548
14	1'-0"			30.209		89'-11"	Pe 2.601
16	-5'-0"			33.358	E(30'-6 1/2"), T(59'-4 1/2")	109'-2 1/2"	Pv
UG	7.9800	Q=616.55	3.96	C=150	0.002501	340'-11 1/4"	Pf 1.053
16	-5'-0"			33.358		79'-11 1/4"	Pe
5	-5'-0"			34.411	2EE(13'-7), T(52'-9 3/4")	420'-11 1/4"	Pv
UG	7.9800	Q=956.90	6.14	C=150	0.005639	1'-11"	Pf 0.121
5	-5'-0"			34.411		19'-7 1/2"	Pe
7	-5'-0"			34.532	LtE(19'-7 1/2")	21'-6 1/2"	Pv
UG	8.3900	Q=956.90	5.55	C=140	0.005020	17'-0"	Pf 12.417
7	-5'-0"			34.532		66'-2"	Pe 0.434
9	-6'-0"			47.383	3LtE(22'-0 3/4"), BFP(-12.000)	83'-2"	Pv
UG	7.9800	Q=956.90	6.14	C=150	0.005639	726'-3 1/2"	Pf 4.768
9	-6'-0"			47.383		119'-2 1/2"	Pe
1	-6'-0"			52.151	2E(27'-2), 2GV(6'-0 1/2"), T(52'-9 3/4"), S	845'-6 1/4"	Pv
<b>Route 2</b>							
CM	2.1570	Q=21.19	1.86	C=120	0.004326	11'-0"	Pf 0.048
104	31'-3"	q=21.19	K=8	7.015	Spr(-7.015)		Pe 1.863
105	26'-11 1/4"			8.926		11'-0"	Pv
CM	2.1570	Q=45.09	3.96	C=120	0.017493	11'-0"	Pf 0.192
105	26'-11 1/4"	q=23.90	K=8	8.926	Spr(-8.926)		Pe 1.863
106	22'-7 3/4"			10.982		11'-0"	Pv
CM	2.1570	Q=71.60	6.29	C=120	0.041155	4'-7 1/4"	Pf 0.342
106	22'-7 3/4"	q=26.51	K=8	10.982	Spr(-10.982)	3'-8 1/4"	Pe 1.509
100	19'-2"			12.832	LtE(3'-8 1/4")	8'-3 3/4"	Pv
DY	2.1570	Q=71.60	6.29	C=120	0.041155	0'-0"	Pf 0.506
100	19'-2"			12.832		12'-3 3/4"	Pe 0.175
119	18'-9 1/4"			13.513	PO(12'-3 3/4")	12'-3 3/4"	Pv
CM	4.2600	Q=57.95	1.30	C=120	0.001012	10'-0"	Pf 0.010
119	18'-9 1/4"			13.513			Pe
118	18'-9 1/4"			13.524		10'-0"	Pv
CM	4.2600	Q=129.59	2.92	C=120	0.004484	10'-0"	Pf 0.045
118	18'-9 1/4"			13.524			Pe 0.000
117	18'-9 1/4"			13.568		10'-0"	Pv
CM	4.2600	Q=201.33	4.53	C=120	0.010131	10'-0"	Pf 0.101
117	18'-9 1/4"			13.568			Pe -0.000
116	18'-9 1/4"			13.670		10'-0"	Pv
CM	4.2600	Q=273.43	6.15	C=120	0.017848	10'-0"	Pf 0.178
116	18'-9 1/4"			13.670			Pe -0.000
115	18'-9 1/4"			13.848		10'-0"	Pv
CM	4.2600	Q=346.25	7.79	C=120	0.027625	10'-0"	Pf 0.276
115	18'-9 1/4"			13.848			Pe
114	18'-9 1/4"			14.124		10'-0"	Pv

# Hydraulic Analysis

Job Number: 269-941989101 R1  
Report Description: Ordinary Group II

Pipe Type	Diameter	Flow	Velocity	HWC	Friction Loss	Length	Pressure
Downstream	Elevation	Discharge	K-Factor	Pt	Pn	Eq. Length	Summary
Upstream						Total Length	
CM	4.2600	Q=420.06	9.46	C=120		10'-0"	Pf 0.395
114	18'-9"			14.124			Pe
113	18'-9"			14.519		10'-0"	Pv
CM	4.2600	Q=495.25	11.15	C=120		10'-0"	Pf 0.536
113	18'-9"			14.519			Pe
112	18'-9"			15.055		10'-0"	Pv
CM	4.2600	Q=572.30	12.88	C=120		2'-1"	Pf 0.146
112	18'-9"			15.055			Pe 0.000
146	18'-9"			15.201		2'-1"	Pv
CM	6.3570	Q=572.30	5.79	C=120		7'-9"	Pf 0.077
146	18'-9"			15.201			Pe -0.000
148	18'-9"			15.278		7'-9"	Pv
CM	6.3570	Q=650.02	6.57	C=120		10'-0"	Pf 0.126
148	18'-9"			15.278			Pe -0.000
147	18'-9"			15.404		10'-0"	Pv
CM	6.3570	Q=728.17	7.36	C=120		10'-0"	Pf 0.156
147	18'-9"			15.404			Pe -0.000
162	18'-9"			15.560		10'-0"	Pv
CM	6.3570	Q=728.17	7.36	C=120		10'-0"	Pf 0.156
162	18'-9"			15.560			Pe -0.000
161	18'-9"			15.715		10'-0"	Pv
CM	6.3570	Q=728.17	7.36	C=120		10'-0"	Pf 0.156
161	18'-9"			15.715			Pe -0.000
160	18'-9"			15.871		10'-0"	Pv
CM	6.3570	Q=728.17	7.36	C=120		10'-0"	Pf 0.156
160	18'-9"			15.871			Pe 0.000
159	18'-9"			16.027		10'-0"	Pv
CM	6.3570	Q=728.17	7.36	C=120		10'-0"	Pf 0.156
159	18'-9"			16.027			Pe -0.000
158	18'-9"			16.182		10'-0"	Pv
CM	6.3570	Q=728.17	7.36	C=120		40'-0½"	Pf 1.210
158	18'-9"			16.182		37'-8¾"	Pe -0.000
316	18'-9"			17.392		77'-9"	Pv
***** Route 3 *****							
CM	2.1570	Q=21.19	1.86	C=120		11'-0"	Pf 0.048
107	31'-3"	q=21.19	K=8	7.018			Pe 1.863
108	26'-11¼"			8.929		11'-0"	Pv
CM	2.1570	Q=45.10	3.96	C=120		11'-0"	Pf 0.192
108	26'-11¼"	q=23.91	K=8	8.929			Pe 1.863
109	22'-7¾"			10.985		11'-0"	Pv
CM	2.1570	Q=71.61	6.29	C=120		5'-0½"	Pf 0.867
109	22'-7¾"	q=26.52	K=8	10.985		16'-0"	Pe 1.683
121	18'-9"			13.535		21'-0½"	Pv
***** Route 4 *****							
CM	2.1570	Q=21.20	1.86	C=120		11'-0"	Pf 0.048
110	31'-3"	q=21.20	K=8	7.024			Pe 1.863
111	26'-11¼"			8.935		11'-0"	Pv
CM	2.1570	Q=45.12	3.96	C=120		11'-0"	Pf 0.193
111	26'-11¼"	q=23.91	K=8	8.935			Pe 1.863
608	22'-7¾"			10.991		11'-0"	Pv
CM	2.1570	Q=71.64	6.29	C=120		4'-7¼"	Pf 0.342
608	22'-7¾"	q=26.52	K=8	10.991		3'-8¼"	Pe 1.509
99	19'-2"			12.842		8'-3¾"	Pv
DY	2.1570	Q=71.64	6.29	C=120		0'-0"	Pf 0.507
99	19'-2"			12.842		12'-3¾"	Pe 0.175
118	18'-9"			13.524		12'-3¾"	Pv
***** Route 5 *****							
CM	2.1570	Q=21.24	1.86	C=120		11'-0"	Pf 0.048
625	31'-3"	q=21.24	K=8	7.048			Pe 1.863
616	26'-11¼"			8.960		11'-0"	Pv
CM	2.1570	Q=45.19	3.97	C=120		11'-0"	Pf 0.193
616	26'-11¼"	q=23.95	K=8	8.960			Pe 1.863
607	22'-7¾"			11.016		11'-0"	Pv
CM	2.1570	Q=71.74	6.30	C=120		5'-0½"	Pf 0.869
607	22'-7¾"	q=26.55	K=8	11.016		16'-0"	Pe 1.683
117	18'-9"			13.568		21'-0½"	Pv
***** Route 6 *****							
CM	2.1570	Q=21.30	1.87	C=120		11'-0"	Pf 0.048
626	31'-3"	q=21.30	K=8	7.092			Pe 1.863
617	26'-11¼"			9.003		11'-0"	Pv
CM	2.1570	Q=45.31	3.98	C=120		11'-0"	Pf 0.194
617	26'-11¼"	q=24.00	K=8	9.003			Pe 1.863
609	22'-7¾"			11.060		11'-0"	Pv



# Hydraulic Analysis

Job Number: 269-941989101 R1  
Report Description: Ordinary Group II

Pipe Type	Diameter	Flow	Velocity	HWC	Friction Loss	Length	Pressure
Downstream	Elevation	Discharge	K-Factor	Pt	Pn	Eq. Length	Summary
Upstream						Total Length	
CM	2.1570	Q=71.91	6.31	C=120		4'-7 1/4"	Pf 0.345
609	22'-7 3/4"	q=26.61	K=8	11.060	Spr(-11.060)	3'-8 1/4"	Pe 1.509
155	19'-2"			12.913	LtE(3'-8 1/4")	8'-3 3/4"	Pv
DY	2.1570	Q=71.91	6.31	C=120		0'-0"	Pf 0.511
155	19'-2"			12.913		12'-3 3/4"	Pe 0.175
122	18'-9 1/4"			13.599	PO(12'-3 3/4")	12'-3 3/4"	Pv
***** Route 7 *****							
CM	2.1570	Q=21.37	1.88	C=120		11'-0"	Pf 0.048
624	31'-3"	q=21.37	K=8	7.139	Spr(-7.139)		Pe 1.863
615	26'-11 1/4"			9.051		11'-0"	Pv
CM	2.1570	Q=45.44	3.99	C=120		11'-0"	Pf 0.195
615	26'-11 1/4"	q=24.07	K=8	9.051	Spr(-9.051)		Pe 1.863
606	22'-7 3/4"			11.109		11'-0"	Pv
CM	2.1570	Q=72.11	6.33	C=120		5'-0 1/2"	Pf 0.878
606	22'-7 3/4"	q=26.66	K=8	11.109	Spr(-11.109)	16'-0"	Pe 1.683
116	18'-9 1/4"			13.670	LtE(3'-8 1/4"), PO(12'-3 3/4")	21'-0 1/2"	Pv
***** Route 8 *****							
CM	2.1570	Q=21.64	1.90	C=120		11'-0"	Pf 0.049
623	31'-3"	q=21.64	K=8	7.315	Spr(-7.315)		Pe 1.863
123	26'-11 1/4"			9.228		11'-0"	Pv
CM	2.1570	Q=45.94	4.03	C=120		11'-0"	Pf 0.199
123	26'-11 1/4"	q=24.30	K=8	9.228	Spr(-9.228)		Pe 1.863
124	22'-7 3/4"			11.290		11'-0"	Pv
CM	2.1570	Q=72.82	6.39	C=120		4'-7 1/4"	Pf 0.353
124	22'-7 3/4"	q=26.88	K=8	11.290	Spr(-11.290)	3'-8 1/4"	Pe 1.509
96	19'-2"			13.151	LtE(3'-8 1/4")	8'-3 3/4"	Pv
DY	2.1570	Q=72.82	6.39	C=120		0'-0"	Pf 0.523
96	19'-2"			13.151		12'-3 3/4"	Pe 0.175
115	18'-9 1/4"			13.848	PO(12'-3 3/4")	12'-3 3/4"	Pv
***** Route 9 *****							
CM	2.1570	Q=22.00	1.93	C=120		11'-0"	Pf 0.051
125	31'-3"	q=22.00	K=8	7.562	Spr(-7.562)		Pe 1.863
126	26'-11 1/4"			9.476		11'-0"	Pv
CM	2.1570	Q=46.63	4.09	C=120		11'-0"	Pf 0.205
126	26'-11 1/4"	q=24.63	K=8	9.476	Spr(-9.476)		Pe 1.863
127	22'-7 3/4"			11.544		11'-0"	Pv
CM	2.1570	Q=73.81	6.48	C=120		4'-7 1/4"	Pf 0.362
127	22'-7 3/4"	q=27.18	K=8	11.544	Spr(-11.544)	3'-8 1/4"	Pe 1.509
95	19'-2"			13.414	LtE(3'-8 1/4")	8'-3 3/4"	Pv
DY	2.1570	Q=73.81	6.48	C=120		0'-0"	Pf 0.536
95	19'-2"			13.414		12'-3 3/4"	Pe 0.175
114	18'-9 1/4"			14.124	PO(12'-3 3/4")	12'-3 3/4"	Pv
***** Route 10 *****							
CM	2.1570	Q=22.51	1.98	C=120		11'-0"	Pf 0.053
128	31'-3"	q=22.51	K=8	7.915	Spr(-7.915)		Pe 1.863
129	26'-11 1/4"			9.832		11'-0"	Pv
CM	2.1570	Q=47.59	4.18	C=120		11'-0"	Pf 0.213
129	26'-11 1/4"	q=25.08	K=8	9.832	Spr(-9.832)		Pe 1.863
130	22'-7 3/4"			11.908		11'-0"	Pv
CM	2.1570	Q=75.20	6.60	C=120		4'-7 1/4"	Pf 0.374
130	22'-7 3/4"	q=27.61	K=8	11.908	Spr(-11.908)	3'-8 1/4"	Pe 1.509
94	19'-2"			13.790	LtE(3'-8 1/4")	8'-3 3/4"	Pv
DY	2.1570	Q=75.20	6.60	C=120		0'-0"	Pf 0.555
94	19'-2"			13.790		12'-3 3/4"	Pe 0.175
113	18'-9 1/4"			14.519	PO(12'-3 3/4")	12'-3 3/4"	Pv
***** Route 11 *****							
CM	2.1570	Q=23.18	2.04	C=120		11'-0"	Pf 0.056
131	31'-3"	q=23.18	K=8	8.394	Spr(-8.394)		Pe 1.863
132	26'-11 1/4"			10.314		11'-0"	Pv
CM	2.1570	Q=48.87	4.29	C=120		11'-0"	Pf 0.223
132	26'-11 1/4"	q=25.69	K=8	10.314	Spr(-10.314)		Pe 1.863
133	22'-7 3/4"			12.401		11'-0"	Pv
CM	2.1570	Q=77.04	6.76	C=120		4'-7 1/4"	Pf 0.391
133	22'-7 3/4"	q=28.17	K=8	12.401	Spr(-12.401)	3'-8 1/4"	Pe 1.509
93	19'-2"			14.301	LtE(3'-8 1/4")	8'-3 3/4"	Pv
DY	2.1570	Q=77.04	6.76	C=120		0'-0"	Pf 0.580
93	19'-2"			14.301		12'-3 3/4"	Pe 0.175
112	18'-9 1/4"			15.055	PO(12'-3 3/4")	12'-3 3/4"	Pv
***** Route 12 *****							
CM	2.1570	Q=23.43	2.06	C=120		11'-0"	Pf 0.057
134	31'-3"	q=23.43	K=8	8.575	Spr(-8.575)		Pe 1.863
135	26'-11 1/4"			10.496		11'-0"	Pv

# Hydraulic Analysis

Job Number: 269-941989101 R1  
Report Description: Ordinary Group II

Pipe Type	Diameter	Flow	Velocity	HWC	Friction Loss	Length	Pressure
Downstream	Elevation	Discharge	K-Factor	Pt	Pn	Eq. Length	Summary
Upstream					Fittings	Total Length	
CM	2.1570	Q=49.34	4.33	C=120	0.020668	11'-0"	Pf 0.227
135	26'-11 1/4"	q=25.92	K=8	10.496	Spr(-10.496)		Pe 1.863
136	22'-7 3/4"			12.587		11'-0"	Pv
CM	2.1570	Q=77.73	6.82	C=120	0.047903	5'-0 1/2"	Pf 1.008
136	22'-7 3/4"	q=28.38	K=8	12.587	Spr(-12.587)	16'-0"	Pe 1.683
148	18'-9 1/4"			15.278	LtE(3'-8 1/4"), PO(12'-3 3/4")	21'-0 1/2"	Pv
***** Route 13 *****							
CM	2.1570	Q=23.58	2.07	C=120	0.005273	11'-0"	Pf 0.058
137	31'-3"	q=23.58	K=8	8.688	Spr(-8.688)		Pe 1.863
138	26'-11 1/4"			10.609		11'-0"	Pv
CM	2.1570	Q=49.64	4.36	C=120	0.020896	11'-0"	Pf 0.230
138	26'-11 1/4"	q=26.06	K=8	10.609	Spr(-10.609)		Pe 1.863
139	22'-7 3/4"			12.703		11'-0"	Pv
CM	2.1570	Q=78.15	6.86	C=120	0.048387	5'-0 1/2"	Pf 1.019
139	22'-7 3/4"	q=28.51	K=8	12.703	Spr(-12.703)	16'-0"	Pe 1.683
147	18'-9 1/4"			15.404	LtE(3'-8 1/4"), PO(12'-3 3/4")	21'-0 1/2"	Pv
***** Route 14 *****							
UG	7.9800	Q=340.34	2.18	C=150	0.000833	1129'-3 1/2"	Pf 1.053
16	-5'-0"			33.358		134'-3 3/4"	Pe
5	-5'-0"			34.411	3E(27'-2"), T(52'-9 3/4")	1263'-7 1/4"	Pv
***** Route 15 *****							
CM	4.2600	Q=13.65	0.31	C=120	0.000070	10'-0"	Pf 0.001
119	18'-9 1/4"			13.513			Pe 0.000
120	18'-9 1/4"			13.514		10'-0"	Pv

### Equivalent Pipe Lengths of Valves and Fittings (C=120 only)

$$\left( \frac{\text{Actual Inside Diameter}}{\text{Schedule 40 Steel Pipe Inside Diameter}} \right)^{4.87} = \text{Factor}$$

### C Value Multiplier

Value Of C	100	130	140	150
Multiplying Factor	0.713	1.16	1.33	1.51

# Hydraulic Analysis

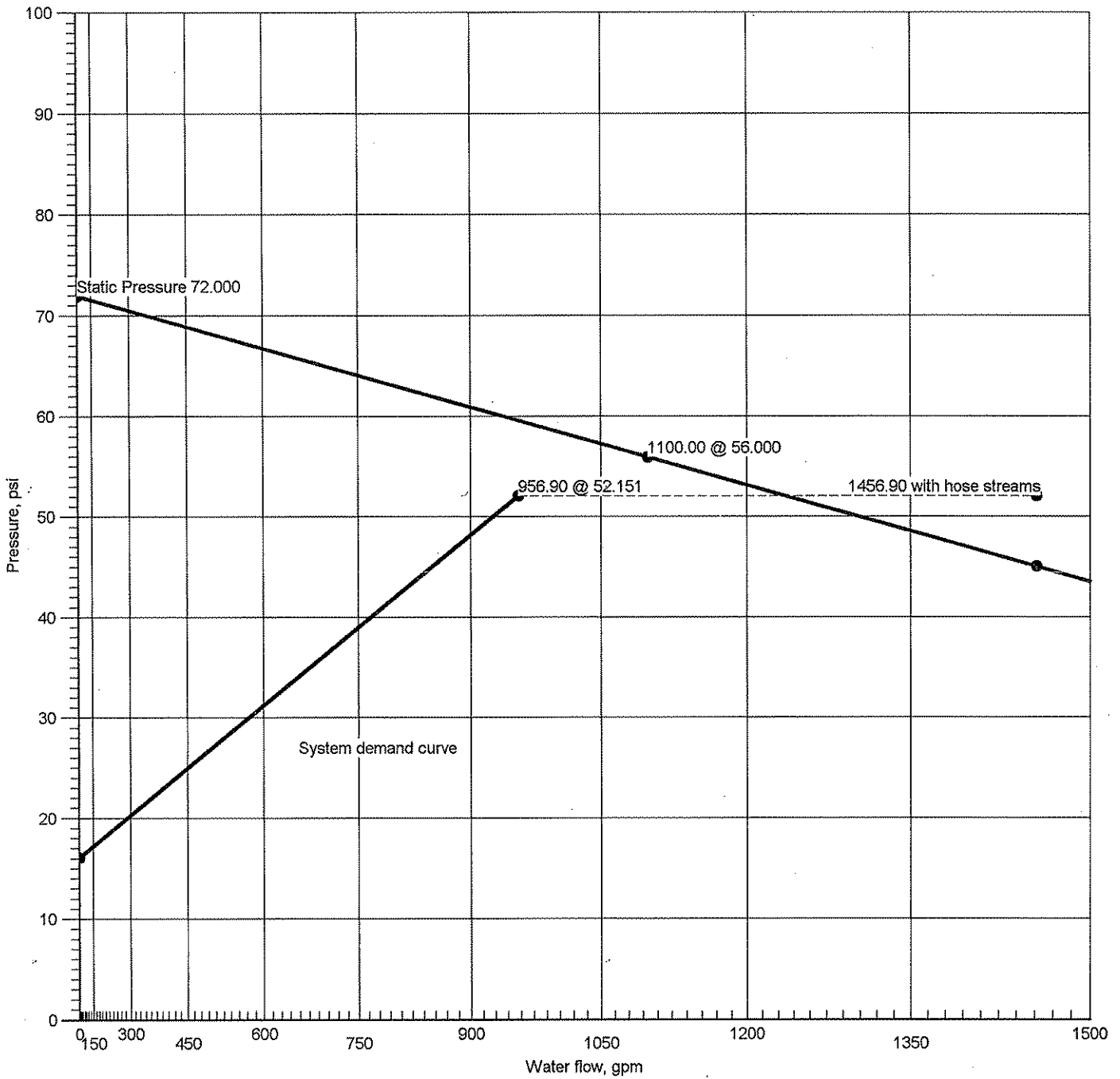
Job Number: 269-941989101 R1  
 Report Description: Ordinary Group II

Pipe Type	Diameter	Flow	Velocity	HWC	Friction Loss	Length	Pressure
Downstream	Elevation	Discharge	K-Factor	Pt	Pn	Eq. Length	Summary
Upstream						Total Length	

Pipe Type Legend		Units Legend		Fittings Legend	
AO	Arm-Over	Diameter	Inch	ALV	Alarm Valve
BL	Branch Line	Elevation	Foot	AngV	Angle Valve
CM	Cross Main	Flow	gpm	b	Bushing
DN	Drain	Discharge	gpm	BalV	Ball Valve
DR	Drop	Velocity	fps	BFP	Backflow Preventer
DY	Dynamic	Pressure	psi	BV	Butterfly Valve
FM	Feed Main	Length	Foot	C	Cross Flow Turn 90°
FR	Feed Riser	Friction Loss	psi/Foot	cplg	Coupling
MS	Miscellaneous	HWC	Hazen-Williams Constant	Cr	Cross Run
OR	Outrigger	Pt	Total pressure at a point in a pipe	CV	Check Valve
RN	Riser Nipple	Pn	Normal pressure at a point in a pipe	DelV	Deluge Valve
SP	Sprig	Pf	Pressure loss due to friction between points	DPV	Dry Pipe Valve
ST	Stand Pipe	Pe	Pressure due to elevation difference between indicated points	E	90° Elbow
UG	Underground	Pv	Velocity pressure at a point in a pipe	EE	45° Elbow
				Ee1	11¼° Elbow
				Ee2	22½° Elbow
				f	Flow Device
				FDC	Fire Department Connection
				fE	90° FireLock(TM) Elbow
				fEE	45° FireLock(TM) Elbow
				flg	Flange
				FN	Floating Node
				FT	FireLock(TM) Tee
				g	Gauge
				GloV	Globe Valve
				GV	Gate Valve
				Hose	Hose
				HV	Hose Valve
				Hyd	Hydrant
				LtE	Long Turn Elbow
				mecT	Mechanical Tee
				Noz	Nozzle
				P1	Pump In
				P2	Pump Out
				PIV	Post Indicating Valve
				PO	Pipe Outlet
				PrV	Pressure Relief Valve
				PRV	Pressure Reducing Valve
				red	Reducer/Adapter
				S	Supply
				sCV	Swing Check Valve
				Spr	Sprinkler
				St	Strainer
				T	Tee Flow Turn 90°
				Tr	Tee Run
				U	Union
				WirF	Wirsbo
				WMV	Water Meter Valve
				Z	Cap



### Supply at Node 1



Hydraulic Graph
Supply at Node 1
Static Pressure
72.000
Residual Pressure
1100.00 @ 56.000
Available Pressure/Time of Test
45.092 @ 1456.90
System Demand
956.90 @ 52.151
System Demand (Including Hose Allowance)
1456.90 @ 52.151





# Hydraulic Overview

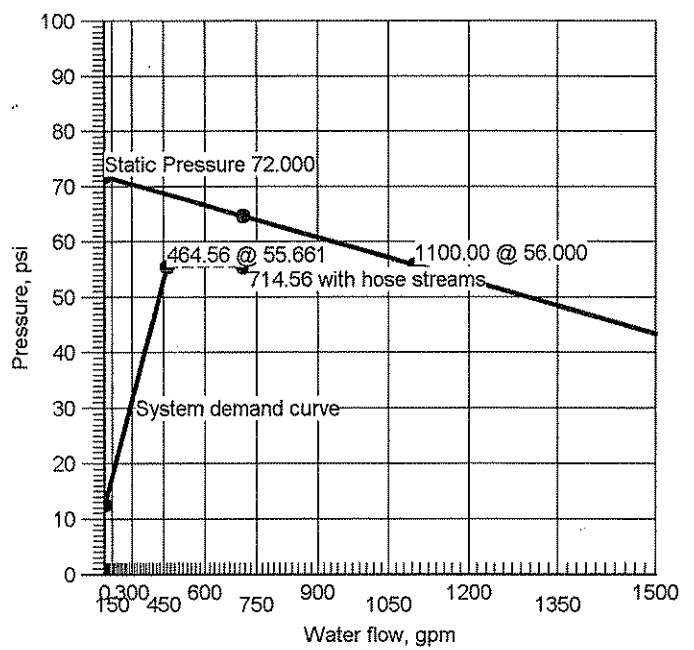
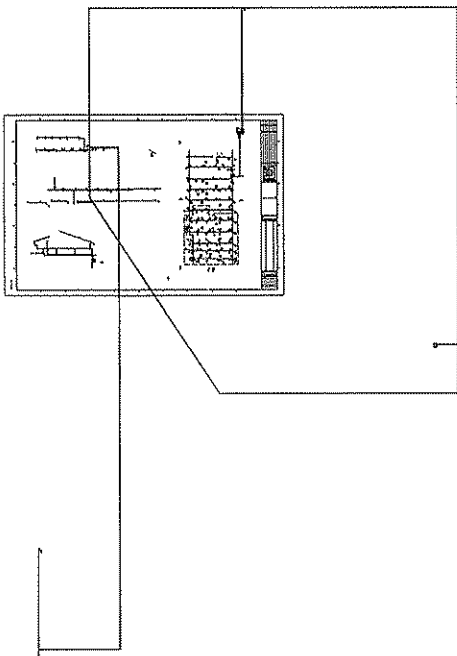
Job Number: 2440 2nd Fl  
Report Description: Light Hazard

Job Number 2440 2nd Fl			Design Engineer		
Job Name STENNIS RIVERINE OPERATIONS BLDG 2ND FLOOR			Phone		FAX
Address 1 OPERATIONS BLDG			State Certification/License Number		
Address 2 STENNIS SPACE CENTER			AHJ		
City STENNIS		State MS	Zip Code	Job Site DEMAND WITH 250 GPM HOSE ALLOWANCE	

System	
Density 0.100gpm/ft <sup>2</sup>	Area of Application 3000.00ft <sup>2</sup> (Actual 3044.18ft <sup>2</sup> )
Most Demanding Sprinkler Data 5.6 K-Factor 14.82 at 7.000	Hose Streams 250.00
Coverage Per Sprinkler 130.00ft <sup>2</sup>	Number Of Sprinklers Calculated 30
System Pressure Demand 55.661	System Flow Demand 464.56
Total Demand 714.56 @ 55.661	Pressure Result +9.136 (14.1%)

Supplies					Check Point Gauges			
<u>Node</u>	<u>Flow(gpm)</u>	<u>Hose Flow(gpm)</u>	<u>Static(psi)</u>	<u>Residual(psi)</u>	<u>Identifier</u>	<u>Pressure(psi)</u>	<u>K-Factor(K)</u>	<u>Flow(gpm)</u>
1	1100.00	250.00	72.000	56.000				

FP-4 BLDG 2440 2441 SECT & 2ND FL R5      Supply at Node 1 (1100.00, 250.00, 72.000, 56.000)





# Summary Of Outflowing Devices

Job Number: 2440 2nd FI  
Report Description: Light Hazard

Device		Actual Flow (gpm)	Minimum Flow (gpm)	K-Factor (K)	Pressure (psi)		
Sprinkler	129	16.69	14.82	5.6	8.883		
Sprinkler	130	16.71	14.82	5.6	8.900		
Sprinkler	127	16.09	14.82	5.6	8.252		
Sprinkler	125	15.88	14.82	5.6	8.040		
Sprinkler	123	15.87	14.82	5.6	8.030		
Sprinkler	124	15.87	14.82	5.6	8.032		
Sprinkler	126	15.90	14.82	5.6	8.063		
Sprinkler	128	16.04	14.82	5.6	8.203		
Sprinkler	122	15.88	14.82	5.6	8.041		
Sprinkler	120	15.65	14.82	5.6	7.814		
Sprinkler	118	15.47	14.82	5.6	7.630		
Sprinkler	116	15.46	14.82	5.6	7.621		
Sprinkler	117	15.46	14.82	5.6	7.624		
Sprinkler	119	15.49	14.82	5.6	7.654		
Sprinkler	121	15.63	14.82	5.6	7.790		
Sprinkler	106	15.04	14.82	5.6	7.209		
Sprinkler	104	14.93	14.82	5.6	7.106		
Sprinkler	102	14.86	14.82	5.6	7.046		
Sprinkler	113	15.26	14.82	5.6	7.427		
Sprinkler	115	15.39	14.82	5.6	7.557		
Sprinkler	110	15.15	14.82	5.6	7.320		
Sprinkler	111	15.20	14.82	5.6	7.370		
Sprinkler	114	15.33	14.82	5.6	7.495		
Sprinkler	103	14.87	14.82	5.6	7.052		
⇒ Sprinkler	101	14.82	14.82	5.6	7.000		
Sprinkler	105	15.02	14.82	5.6	7.194		
Sprinkler	107	15.10	14.82	5.6	7.270		
Sprinkler	109	15.14	14.82	5.6	7.305		
Sprinkler	108	15.11	14.82	5.6	7.285		
Sprinkler	112	15.24	14.82	5.6	7.407		

⇒ Most Demanding Sprinkler Data

# Node Analysis

Node	Elevation(Foot)	Fittings	Pressure(psi)	Discharge(gpm)
3	-5'-0	T(59'-4½)	41.578	
39	9'-0	E(13'-2)	31.537	
74	7'-7¾		32.620	
63	5'-1		36.330	
8	1'-0		38.680	
7	-5'-0	2T(52'-9¾)	41.841	
10	-5'-0	LtE(19'-7½)	41.872	
12	-6'-0	LtE(22'-0¾)	54.416	
216	23'-0	PO(12'-3¾)	15.010	
226	23'-0	2PO(16'-5¾)	12.337	
292	24'-0	T(12'-3¾)	13.867	
239	23'-0	PO(12'-3¾)	15.054	
352	24'-0	LtE(3'-8¼)	14.243	
305	9'-0		28.741	
306	23'-0		15.275	
245	23'-0	2T(20'-2)	15.437	
253	23'-0	PO(12'-3¾)	11.670	
277	23'-0	PO(12'-3¾)	12.723	
391	24'-0	LtE(3'-8¼)	12.062	
507	50'-7	E(3'-0)	0.000	
279	23'-0	PO(12'-3¾)	11.212	
301	23'-0	PO(12'-3¾)	11.727	
528	24'-0	LtE(3'-8¼)	11.183	
313	23'-0	PO(12'-3¾)	10.496	
325	23'-0	PO(12'-3¾)	10.784	
562	24'-0	LtE(3'-8¼)	10.289	
675	4'-9	Z	0.000	
393	23'-0	PO(12'-3¾)	9.705	
641	24'-0	PO(5'-0)	9.265	
643	24'-0	PO(5'-0)	9.284	
410	23'-0	PO(12'-3¾)	10.043	
694	24'-0	LtE(3'-8¼)	9.479	
667	23'-0	PO(6'-0)	9.605	
386	23'-0	PO(5'-0)	8.915	
429	23'-0	PO(12'-3¾)	8.884	
680	24'-0	PO(5'-0)	8.307	
682	24'-0	PO(5'-0)	8.296	
685	24'-0	PO(5'-0)	8.299	
688	24'-0	PO(5'-0)	8.334	
690	24'-0	PO(5'-0)	8.490	
411	23'-0	PO(12'-3¾)	9.370	
731	24'-0	LtE(3'-8¼)	8.514	
450	23'-0	E(2'-0)	8.410	
414	23'-0	PO(6'-0)	8.638	
423	23'-0	PO(5'-0)	8.428	
467	23'-0	PO(12'-3¾)	8.415	
708	24'-0	PO(5'-0)	7.849	
710	24'-0	PO(5'-0)	7.839	
713	24'-0	PO(5'-0)	7.842	
716	24'-0	PO(5'-0)	7.876	
718	24'-0	PO(5'-0)	8.028	
448	23'-0	PO(12'-3¾)	8.892	
761	24'-0	LtE(3'-8¼)	8.051	
788	5'-10½	LtE(3'-8¼)	0.000	
739	24'-0	E(2'-0)	7.393	
741	24'-0	PO(6'-0)	7.575	
745	24'-0	PO(12'-3¾)	7.570	
747	24'-0	PO(5'-0)	7.557	
749	24'-0	PO(5'-0)	7.562	
752	24'-0	PO(5'-0)	7.622	
754	24'-0	PO(5'-0)	7.767	
477	23'-0	PO(12'-3¾)	8.616	
798	24'-0	LtE(3'-8¼)	7.790	
773	24'-0	E(2'-0)	7.335	
775	24'-0	PO(6'-0)	7.515	
777	24'-0	PO(12'-3¾)	7.514	
779	24'-0	PO(5'-0)	7.498	
781	24'-0	PO(5'-0)	7.502	
784	24'-0	PO(5'-0)	7.558	
786	24'-0	PO(5'-0)	7.698	
538	23'-0	PO(12'-3¾)	8.533	
828	24'-0	LtE(3'-8¼)	7.719	
845	24'-0	PO(5'-0)	7.499	
861	24'-0	PO(12'-3¾)	7.499	
863	24'-0	PO(5'-0)	7.481	
865	24'-0	PO(5'-0)	7.485	
868	24'-0	PO(5'-0)	7.540	



# Node Analysis

Node	Elevation(Foot)	Fittings	Pressure(psi)	Discharge(gpm)
870	24'-0	PO(5'-0)	7.678	
661	23'-0	PO(12'-3¾)	8.509	
935	24'-0	LIE(3'-8¼)	7.700	
129	22'-3	Spr(-8.883)	8.883	16.69
130	22'-3	Spr(-8.900)	8.900	16.71
127	22'-3¼	Spr(-8.252)	8.252	16.09
125	22'-3	Spr(-8.040)	8.040	15.88
123	22'-3	Spr(-8.030)	8.030	15.87
124	22'-3	Spr(-8.032)	8.032	15.87
126	22'-3	Spr(-8.063)	8.063	15.90
128	22'-3	Spr(-8.203)	8.203	16.04
122	22'-3¼	Spr(-8.041)	8.041	15.88
120	22'-3¼	Spr(-7.814)	7.814	15.65
118	22'-3	Spr(-7.630)	7.630	15.47
116	22'-3	Spr(-7.621)	7.621	15.46
117	22'-3	Spr(-7.624)	7.624	15.46
119	22'-3	Spr(-7.654)	7.654	15.49
121	22'-3	Spr(-7.790)	7.790	15.63
106	22'-3¼	Spr(-7.209)	7.209	15.04
104	23'-3	Spr(-7.106)	7.106	14.93
102	23'-3¼	Spr(-7.046)	7.046	14.86
113	22'-3	Spr(-7.427)	7.427	15.26
115	22'-3	Spr(-7.557)	7.557	15.39
110	22'-3	Spr(-7.320)	7.320	15.15
111	22'-3	Spr(-7.370)	7.370	15.20
114	22'-3	Spr(-7.495)	7.495	15.33
103	23'-3	Spr(-7.052)	7.052	14.87
101	23'-3	Spr(-7.000)	7.000	14.82
105	22'-3	Spr(-7.194)	7.194	15.02
107	22'-3	Spr(-7.270)	7.270	15.10
109	22'-3	Spr(-7.305)	7.305	15.14
108	22'-3	Spr(-7.285)	7.285	15.11
112	22'-3	Spr(-7.407)	7.407	15.24
1	-6'-0	S	55.661	464.56



# Hydraulic Analysis

Job Number: 2440 2nd Fl  
Report Description: Light Hazard

Pipe Type	Diameter	Flow	Velocity	HWC		Friction Loss	Length	Pressure
Downstream	Elevation	Discharge	K-Factor	Pt	Pn	Fittings	Eq. Length	Summary
Upstream							Total Length	
<b>Route 1</b>								
DR	1.0490	Q=14.82	5.50	C=120		0.074703	2'-0"	Pf 0.823
101	23'-3"	q=14.82	K=5.6	7.000		Spr(-7.000)	9'-0"	Pe -0.325
779	24'-0"			7.498		2E(2'-0), PO(5'-0)	11'-0"	Pv
CM	2.1570	Q=5.83	0.51	C=120		0.000398	9'-8"	Pf 0.004
779	24'-0"			7.498				Pe 0.000
781	24'-0"			7.502			9'-8"	Pv
CM	2.1570	Q=20.98	1.84	C=120		0.004248	13'-2"	Pf 0.056
781	24'-0"			7.502				Pe -0.000
784	24'-0"			7.558			13'-2"	Pv
CM	2.1570	Q=36.18	3.18	C=120		0.011643	12'-0"	Pf 0.140
784	24'-0"			7.558				Pe
786	24'-0"			7.698			12'-0"	Pv
CM	2.1570	Q=51.52	4.52	C=120		0.022381	0'-11 1/2"	Pf 0.021
786	24'-0"			7.698				Pe
828	24'-0"			7.719			0'-11 1/2"	Pv
RN	2.1570	Q=51.52	4.52	C=120		0.022381	1'-0"	Pf 0.380
828	24'-0"			7.719		LtE(3'-8 1/4)	16'-0"	Pe 0.434
538	23'-0"			8.533		PO(12'-3 1/4)	17'-0"	Pv
CM	3.2600	Q=102.73	3.95	C=120		0.010737	7'-8 1/2"	Pf 0.083
538	23'-0"			8.533				Pe
477	23'-0"			8.616			7'-8 1/2"	Pv
CM	3.2600	Q=155.14	5.96	C=120		0.023021	12'-0"	Pf 0.276
477	23'-0"			8.616				Pe
448	23'-0"			8.892			12'-0"	Pv
CM	3.2600	Q=208.62	8.02	C=120		0.039819	12'-0"	Pf 0.478
448	23'-0"			8.892				Pe
411	23'-0"			9.370			12'-0"	Pv
CM	3.2600	Q=263.13	10.11	C=120		0.061180	11'-0"	Pf 0.673
411	23'-0"			9.370				Pe
410	23'-0"			10.043			11'-0"	Pv
CM	3.2600	Q=291.96	11.22	C=120		0.074152	10'-0"	Pf 0.742
410	23'-0"			10.043				Pe 0.000
325	23'-0"			10.784			10'-0"	Pv
CM	3.2600	Q=311.31	11.97	C=120		0.083502	11'-3 1/2"	Pf 0.943
325	23'-0"			10.784				Pe -0.000
301	23'-0"			11.727			11'-3 1/2"	Pv
CM	3.2600	Q=337.78	12.98	C=120		0.097109	10'-3"	Pf 0.995
301	23'-0"			11.727				Pe
277	23'-0"			12.723			10'-3"	Pv
CM	3.2600	Q=376.73	14.48	C=120		0.118831	2'-8 1/4"	Pf 2.714
277	23'-0"			12.723			20'-2"	Pe
245	23'-0"			15.437		T(20'-2)	22'-10"	Pv
CM	3.2600	Q=464.56	17.86	C=120		0.175108	21'-2"	Pf 7.237
245	23'-0"			15.437			20'-2"	Pe 6.067
305	9'-0"			28.741		3LtE(6'-8 1/4)	41'-4"	Pv
FM	4.2600	Q=464.56	10.46	C=120		0.047583	45'-7 1/4"	Pf 2.797
305	9'-0"			28.741			13'-2"	Pe
39	9'-0"			31.537		E(13'-2)	58'-9 1/4"	Pv
FR	4.2600	Q=464.56	10.46	C=120		0.047583	2'-5"	Pf 0.491
39	9'-0"			31.537			7'-10 1/4"	Pe 0.592
74	7'-7 1/4"			32.620		LtE(7'-10 1/4)	10'-4"	Pv
MS	4.2600	Q=464.56	10.46	C=120		0.047583	2'-0"	Pf 2.602
74	7'-7 1/4"			32.620			52'-8"	Pe 1.109
63	5'-1"			36.330		2f(-0.000), CV(28'-11 1/2), BV(15'-9 1/2), LtE(7'-10 1/4)	54'-8"	Pv
FR	6.0650	Q=464.56	5.16	C=120		0.008517	2'-0"	Pf 0.579
63	5'-1"			36.330			66'-0"	Pe 1.770
8	1'-0"			38.680		C(30'-0), CV(16'-0), 2BV(10'-0)	68'-0"	Pv
UG	8.3900	Q=464.56	2.70	C=140		0.001319	135'-2 1/2"	Pf 0.297
8	1'-0"			38.680			89'-11"	Pe 2.601
3	-5'-0"			41.578		E(30'-6 1/2), T(59'-4 1/2)	225'-1 1/2"	Pv
UG	7.9800	Q=306.35	1.97	C=150		0.000686	303'-2 3/4"	Pf 0.263
3	-5'-0"			41.578			79'-11 1/4"	Pe
7	-5'-0"			41.841		E(27'-2), T(52'-9 1/4)	383'-2 1/2"	Pv
UG	7.9800	Q=464.56	2.98	C=150		0.001481	1'-11"	Pf 0.032
7	-5'-0"			41.841			19'-7 1/2"	Pe
10	-5'-0"			41.872		LtE(19'-7 1/2)	21'-6 1/2"	Pv
UG	8.3900	Q=464.56	2.70	C=140		0.001319	17'-0"	Pf 12.110
10	-5'-0"			41.872			66'-2"	Pe 0.434
12	-6'-0"			54.416		3LtE(22'-0 3/4), BFP(-12.000)	83'-2"	Pv

# Hydraulic Analysis

Job Number: 2440 2nd Fl  
Report Description: Light Hazard

Pipe Type	Diameter	Flow	Velocity	HWC	Pn	Friction Loss	Length	Pressure
Downstream	Elevation	Discharge	K-Factor	Pt		Fittings	Eq. Length	Summary
Upstream							Total Length	
UG	7.9800	Q=464.56	2.98	C=150		0.001481	727'-3"	Pf 1.245
12	-6'-0"			54.416			113'-2 1/4"	Pe
1	-6'-0"			55.661		2E(27'-2), GV(6'-0 1/2), T(52'-9 3/4), S	840'-5 1/4"	Pv
***** Route 2 *****								
DR	1.0490	Q=14.86	5.52	C=120		0.075158	2'-0"	Pf 0.827
102	23'-3 1/4"	q=14.86	K=5.6	7.046		Spr(-7.046)	9'-0"	Pe -0.316
747	24'-0"			7.557		2E(2'-0), PO(5'-0)	11'-0"	Pv
CM	2.1570	Q=6.72	0.59	C=120		0.000517	9'-8"	Pf 0.005
747	24'-0"			7.557				Pe 0.000
749	24'-0"			7.562			9'-8"	Pv
CM	2.1570	Q=21.76	1.91	C=120		0.004543	13'-2"	Pf 0.060
749	24'-0"			7.562				Pe -0.000
752	24'-0"			7.622			13'-2"	Pv
CM	2.1570	Q=37.02	3.25	C=120		0.012145	12'-0"	Pf 0.146
752	24'-0"			7.622				Pe
754	24'-0"			7.767			12'-0"	Pv
CM	2.1570	Q=52.41	4.60	C=120		0.023108	0'-11 1/2"	Pf 0.022
754	24'-0"			7.767				Pe
798	24'-0"			7.790			0'-11 1/2"	Pv
RN	2.1570	Q=52.41	4.60	C=120		0.023108	1'-0"	Pf 0.393
798	24'-0"			7.790		LtE(3'-8 1/4)	16'-0"	Pe 0.434
477	23'-0"			8.616		PO(12'-3 3/4)	17'-0"	Pv
***** Route 3 *****								
DR	1.0490	Q=14.87	5.52	C=120		0.075217	2'-1"	Pf 0.608
103	23'-3"	q=14.87	K=5.6	7.052		Spr(-7.052)	6'-0"	Pe -0.325
773	24'-0"			7.335		3E(2'-0)	8'-1"	Pv
BL	1.3800	Q=14.87	3.19	C=120		0.019783	3'-1 1/2"	Pf 0.181
773	24'-0"			7.335			6'-0"	Pe
775	24'-0"			7.515		PO(6'-0)	9'-1 1/2"	Pv
CM	2.6350	Q=48.26	2.84	C=120		0.007482	7'-3 3/4"	Pf 0.054
775	24'-0"			7.515				Pe
745	24'-0"			7.570			7'-3 3/4"	Pv
CM	2.6350	Q=56.40	3.32	C=120		0.009984	0'-6"	Pf 0.005
745	24'-0"			7.570				Pe
741	24'-0"			7.575			0'-6"	Pv
CM	2.6350	Q=71.33	4.20	C=120		0.015416	15'-4 1/2"	Pf 0.406
741	24'-0"			7.575			10'-11 3/4"	Pe 0.434
467	23'-0"			8.415		2LtE(5'-6)	26'-4 1/4"	Pv
CM	2.6350	Q=95.36	5.61	C=120		0.026381	0'-6"	Pf 0.013
467	23'-0"			8.415				Pe
423	23'-0"			8.428			0'-6"	Pv
CM	2.6350	Q=111.01	6.53	C=120		0.034946	6'-0"	Pf 0.210
423	23'-0"			8.428				Pe
414	23'-0"			8.638			6'-0"	Pv
CM	2.6350	Q=126.89	7.47	C=120		0.044753	5'-6"	Pf 0.246
414	23'-0"			8.638				Pe
429	23'-0"			8.884			5'-6"	Pv
CM	2.6350	Q=151.94	8.94	C=120		0.062452	0'-6"	Pf 0.031
429	23'-0"			8.884				Pe
386	23'-0"			8.915			0'-6"	Pv
CM	2.6350	Q=168.03	9.89	C=120		0.075232	9'-2"	Pf 0.690
386	23'-0"			8.915				Pe
667	23'-0"			9.605			9'-2"	Pv
CM	2.6350	Q=168.03	9.89	C=120		0.075232	1'-4"	Pf 0.100
667	23'-0"			9.605				Pe
393	23'-0"			9.705			1'-4"	Pv
CM	2.6350	Q=172.60	10.15	C=120		0.079065	10'-0"	Pf 0.791
393	23'-0"			9.705				Pe
313	23'-0"			10.496			10'-0"	Pv
CM	2.1570	Q=19.36	1.70	C=120		0.003660	45'-11"	Pf 0.227
313	23'-0"			10.496		PO(12'-3 3/4)	16'-0"	Pe -0.434
562	24'-0"			10.289		LtE(3'-8 1/4)	61'-11"	Pv
RN	2.1570	Q=19.36	1.70	C=120		0.003660	1'-0"	Pf 0.062
562	24'-0"			10.289		LtE(3'-8 1/4)	16'-0"	Pe 0.434
325	23'-0"			10.784		PO(12'-3 3/4)	17'-0"	Pv
***** Route 4 *****								
DR	1.0490	Q=14.93	5.54	C=120		0.075748	2'-1"	Pf 0.612
104	23'-3"	q=14.93	K=5.6	7.106		Spr(-7.106)	6'-0"	Pe -0.325
739	24'-0"			7.393		3E(2'-0)	8'-1"	Pv
BL	1.3800	Q=14.93	3.20	C=120		0.019922	3'-1 1/2"	Pf 0.182
739	24'-0"			7.393			6'-0"	Pe
741	24'-0"			7.575		PO(6'-0)	9'-1 1/2"	Pv
***** Route 5 *****								

# Hydraulic Analysis

Job Number: 2440 2nd Fl  
Report Description: Light Hazard

Pipe Type	Diameter	Flow	Velocity	HWC	Friction Loss	Length	Pressure
Downstream	Elevation	Discharge	K-Factor	Pt	Pn	Eq. Length	Summary
Upstream						Total Length	
DR	1.0490	Q=15.02	5.58	C=120			
105	22'-3	q=15.02	K=5.6	7.194		4'-10 1/2	Pf 1.063
845	24'-0			7.499		9'-0	Pe -0.759
						13'-10 1/2	Pv
CM	2.6350	Q=24.40	1.44	C=120			
845	24'-0			7.499		7'-0 3/4	Pf 0.015
777	24'-0			7.514		7'-0 3/4	Pe
							Pv
CM	2.6350	Q=33.39	1.96	C=120			
777	24'-0			7.514		0'-5 1/4	Pf 0.002
775	24'-0			7.515		0'-5 1/4	Pe
							Pv
***** Route 6 *****							
DR	1.0490	Q=15.04	5.58	C=120			
106	22'-3 1/4	q=15.04	K=5.6	7.209		5'-4 1/4	Pf 1.102
749	24'-0			7.562		9'-0	Pe -0.750
						14'-4 1/4	Pv
***** Route 7 *****							
DR	1.0490	Q=15.10	5.61	C=120			
107	22'-3	q=15.10	K=5.6	7.270		3'-6 1/4	Pf 0.969
863	24'-0			7.481		9'-0	Pe -0.759
						12'-6 1/4	Pv
CM	2.1570	Q=5.72	0.50	C=120			
863	24'-0			7.481		9'-4	Pf 0.004
865	24'-0			7.485		9'-4	Pe 0.000
							Pv
CM	2.1570	Q=20.86	1.83	C=120			
865	24'-0			7.485		13'-2	Pf 0.055
868	24'-0			7.540		13'-2	Pe -0.000
							Pv
CM	2.1570	Q=35.97	3.16	C=120			
868	24'-0			7.540		12'-0	Pf 0.138
870	24'-0			7.678		12'-0	Pe
							Pv
CM	2.1570	Q=51.21	4.50	C=120			
870	24'-0			7.678		0'-11 1/2	Pf 0.021
935	24'-0			7.700		0'-11 1/2	Pe
							Pv
RN	2.1570	Q=51.21	4.50	C=120			
935	24'-0			7.700		1'-0	Pf 0.376
661	23'-0			8.509		16'-0	Pe 0.434
						17'-0	Pv
CM	3.2600	Q=51.21	1.97	C=120			
661	23'-0			8.509		8'-0	Pf 0.024
538	23'-0			8.533		8'-0	Pe
							Pv
***** Route 8 *****							
DR	1.0490	Q=15.11	5.61	C=120			
108	22'-3	q=15.11	K=5.6	7.285		4'-1	Pf 1.014
868	24'-0			7.540		9'-0	Pe -0.759
						13'-1	Pv
***** Route 9 *****							
DR	1.0490	Q=15.14	5.62	C=120			
109	22'-3	q=15.14	K=5.6	7.305		3'-1	Pf 0.939
865	24'-0			7.485		9'-0	Pe -0.759
						12'-1	Pv
***** Route 10 *****							
DR	1.0490	Q=15.15	5.62	C=120			
110	22'-3	q=15.15	K=5.6	7.320		3'-1	Pf 0.941
781	24'-0			7.502		9'-0	Pe -0.759
						12'-1	Pv
***** Route 11 *****							
DR	1.0490	Q=15.20	5.64	C=120			
111	22'-3	q=15.20	K=5.6	7.370		3'-1	Pf 0.947
784	24'-0			7.558		9'-0	Pe -0.759
						12'-1	Pv
***** Route 12 *****							
DR	1.0490	Q=15.24	5.66	C=120			
112	22'-3	q=15.24	K=5.6	7.407		4'-1	Pf 1.030
870	24'-0			7.678		9'-0	Pe -0.759
						13'-1	Pv
***** Route 13 *****							
DR	1.0490	Q=15.26	5.67	C=120			
113	22'-3	q=15.26	K=5.6	7.427		3'-1	Pf 0.953
752	24'-0			7.622		9'-0	Pe -0.759
						12'-1	Pv
***** Route 14 *****							
DR	1.0490	Q=15.33	5.69	C=120			
114	22'-3	q=15.33	K=5.6	7.495		3'-1	Pf 0.962
786	24'-0			7.698		9'-0	Pe -0.759
						12'-1	Pv
***** Route 15 *****							
DR	1.0490	Q=15.39	5.71	C=120			
115	22'-3	q=15.39	K=5.6	7.557		3'-1	Pf 0.969
754	24'-0			7.767		9'-0	Pe -0.759
						12'-1	Pv
***** Route 16 *****							
DR	1.0490	Q=15.46	5.74	C=120			
116	22'-3	q=15.46	K=5.6	7.621		3'-1	Pf 0.976
710	24'-0			7.839		9'-0	Pe -0.759
						12'-1	Pv



# Hydraulic Analysis

Job Number: 2440 2nd Fl  
Report Description: Light Hazard

Pipe Type	Diameter	Flow	Velocity	HWC	Friction Loss	Length	Pressure
Downstream	Elevation	Discharge	K-Factor	Pt	Pn	Eq. Length	Summary
Upstream						Total Length	
CM	2.1570	Q=6.89	0.61	C=120		0.000542	
710	24'-0			7.839			5'-5% Pf 0.003
713	24'-0			7.842			Pe 5'-5% Pv
CM	2.1570	Q=22.36	1.96	C=120		0.004778	
713	24'-0			7.842			7'-2 Pf 0.034
716	24'-0			7.876			Pe 7'-2 Pv
CM	2.1570	Q=37.85	3.32	C=120		0.012654	
716	24'-0			7.876			12'-0 Pf 0.152
718	24'-0			8.028			Pe 12'-0 Pv
CM	2.1570	Q=53.48	4.70	C=120		0.023986	
718	24'-0			8.028			0'-11½ Pf 0.023
761	24'-0			8.051			Pe 0'-11½ Pv
RN	2.1570	Q=53.48	4.70	C=120		0.023986	
761	24'-0			8.051			1'-0 Pf 0.408
448	23'-0			8.892			16'-0 Pe 0.434
							17'-0 Pv
<b>Route 17</b>							
DR	1.0490	Q=15.46	5.74	C=120		0.080840	
117	22'-3	q=15.46	K=5.6	7.624			3'-1 Pf 0.977
713	24'-0			7.842			9'-0 Pe -0.759
							12'-1 Pv
<b>Route 18</b>							
DR	1.0490	Q=15.47	5.74	C=120		0.080899	
118	22'-3	q=15.47	K=5.6	7.630			3'-1 Pf 0.978
708	24'-0			7.849			9'-0 Pe -0.759
							12'-1 Pv
CM	2.1570	Q=24.03	2.11	C=120		0.005461	
708	24'-0			7.849			8'-3% Pf 0.133
467	23'-0			8.415			16'-0 Pe 0.434
							24'-3% Pv
<b>Route 19</b>							
DR	1.0490	Q=15.49	5.75	C=120		0.081140	
119	22'-3	q=15.49	K=5.6	7.654			3'-1 Pf 0.980
716	24'-0			7.876			9'-0 Pe -0.759
							12'-1 Pv
<b>Route 20</b>							
DR	1.0490	Q=15.63	5.80	C=120		0.082470	
121	22'-3	q=15.63	K=5.6	7.790			3'-1 Pf 0.997
718	24'-0			8.028			9'-0 Pe -0.759
							12'-1 Pv
<b>Route 21</b>							
DR	1.0490	Q=15.65	5.81	C=120		0.082702	
120	22'-3¼	q=15.65	K=5.6	7.814			2'-3 Pf 0.930
423	23'-0			8.428			9'-0 Pe -0.316
							11'-3 Pv
<b>Route 22</b>							
DR	1.0490	Q=15.87	5.89	C=120		0.084816	
123	22'-3	q=15.87	K=5.6	8.030			3'-1 Pf 1.025
682	24'-0			8.296			9'-0 Pe -0.759
							12'-1 Pv
CM	2.1570	Q=6.70	0.59	C=120		0.000514	
682	24'-0			8.296			5'-5% Pf 0.003
685	24'-0			8.299			Pe 5'-5% Pv
CM	2.1570	Q=22.57	1.98	C=120		0.004863	
685	24'-0			8.299			7'-2 Pf 0.035
688	24'-0			8.334			Pe 7'-2 Pv
CM	2.1570	Q=38.47	3.38	C=120		0.013043	
688	24'-0			8.334			12'-0 Pf 0.157
690	24'-0			8.490			Pe 12'-0 Pv
CM	2.1570	Q=54.51	4.79	C=120		0.024851	
690	24'-0			8.490			0'-11½ Pf 0.024
731	24'-0			8.514			Pe 0'-11½ Pv
RN	2.1570	Q=54.51	4.79	C=120		0.024851	
731	24'-0			8.514			1'-0 Pf 0.422
411	23'-0			9.370			16'-0 Pe 0.434
							17'-0 Pv
<b>Route 23</b>							
DR	1.0490	Q=15.87	5.89	C=120		0.084840	
124	22'-3	q=15.87	K=5.6	8.032			3'-1 Pf 1.025
685	24'-0			8.299			9'-0 Pe -0.759
							12'-1 Pv
<b>Route 24</b>							
DR	1.0490	Q=15.88	5.89	C=120		0.084912	
125	22'-3	q=15.88	K=5.6	8.040			3'-1 Pf 1.026
680	24'-0			8.307			9'-0 Pe -0.759
							12'-1 Pv
CM	2.1570	Q=25.05	2.20	C=120		0.005895	
680	24'-0			8.307			8'-3% Pf 0.143
429	23'-0			8.884			16'-0 Pe 0.434
							24'-3% Pv
<b>Route 25</b>							
DR	1.0490	Q=15.88	5.90	C=120		0.084930	
122	22'-3¼	q=15.88	K=5.6	8.041			2'-0 Pf 0.685
450	23'-0			8.410			6'-0 Pe -0.316
							8'-0% Pv



# Hydraulic Analysis

Job Number: 2440 2nd Fl  
Report Description: Light Hazard

Pipe Type	Diameter	Flow	Velocity	HWC	Friction Loss		Length	Pressure
Downstream	Elevation	Discharge	K-Factor	Pt	Pn	Fittings	Eq. Length	Summary
Upstream							Total Length	
BL	1.3800	Q=15.88	3.41	C=120		0.022337	4'-2 1/4"	Pf 0.228
450	23'-0"			8.410			6'-0"	Pe
414	23'-0"			8.638		PO(6'-0")	10'-2 1/4"	Pv
<b>Route 26</b>								
DR	1.0490	Q=15.90	5.90	C=120		0.085145	3'-1"	Pf 1.029
126	22'-3"	q=15.90	K=5.6	8.063		Spr(-8.063)	9'-0"	Pe -0.759
688	24'-0"			8.334		2E(2'-0"), PO(5'-0")	12'-1"	Pv
<b>Route 27</b>								
DR	1.0490	Q=16.04	5.95	C=120		0.086511	3'-1"	Pf 1.045
128	22'-3"	q=16.04	K=5.6	8.203		Spr(-8.203)	9'-0"	Pe -0.759
690	24'-0"			8.490		2E(2'-0"), PO(5'-0")	12'-1"	Pv
<b>Route 28</b>								
DR	1.0490	Q=16.09	5.97	C=120		0.086989	2'-3"	Pf 0.979
127	22'-3 1/4"	q=16.09	K=5.6	8.252		Spr(-8.252)	9'-0"	Pe -0.316
386	23'-0"			8.915		2E(2'-0"), PO(5'-0")	11'-3"	Pv
<b>Route 29</b>								
DR	1.0490	Q=16.69	6.20	C=120		0.093122	3'-3"	Pf 1.141
129	22'-3"	q=16.69	K=5.6	8.883		Spr(-8.883)	9'-0"	Pe -0.759
641	24'-0"			9.265		2E(2'-0"), PO(5'-0")	12'-3"	Pv
CM	2.1570	Q=12.12	1.06	C=120		0.001538	12'-0"	Pf 0.018
641	24'-0"			9.265				Pe
643	24'-0"			9.284			12'-0"	Pv
CM	2.1570	Q=28.82	2.53	C=120		0.007644	25'-7 1/4"	Pf 0.196
643	24'-0"			9.284				Pe
694	24'-0"			9.479			25'-7 1/4"	Pv
RN	2.1570	Q=28.82	2.53	C=120		0.007644	1'-0"	Pf 0.130
694	24'-0"			9.479		LtE(3'-8 1/4")	16'-0"	Pe 0.434
410	23'-0"			10.043		PO(12'-3 1/4")	17'-0"	Pv
<b>Route 30</b>								
DR	1.0490	Q=16.71	6.20	C=120		0.093282	3'-3"	Pf 1.143
130	22'-3"	q=16.71	K=5.6	8.900		Spr(-8.900)	9'-0"	Pe -0.759
643	24'-0"			9.284		2E(2'-0"), PO(5'-0")	12'-3"	Pv
<b>Route 31</b>								
DY	3.2600	Q=87.83	3.38	C=120		0.008036	0'-0"	Pf 0.162
306	23'-0"			15.275			20'-2"	Pe
245	23'-0"			15.437		T(20'-2")	20'-2"	Pv
<b>Route 32</b>								
UG	7.9800	Q=158.21	1.01	C=150		0.000202	1167'-0"	Pf 0.263
3	-5'-0"			41.578			134'-3 3/4"	Pe
7	-5'-0"			41.841		2E(27'-2"), 2EE(13'-7"), T(52'-9 3/4")	1301'-3 3/4"	Pv
<b>Route 33</b>								
CM	2.1570	Q=87.83	7.71	C=120		0.060056	29'-0"	Pf 1.963
226	23'-0"			12.337			3'-8 1/4"	Pe -0.434
292	24'-0"			13.867		LtE(3'-8 1/4")	32'-8 1/4"	Pv
CM	2.1570	Q=51.32	4.51	C=120		0.022227	16'-11"	Pf 0.376
292	24'-0"			13.867				Pe
352	24'-0"			14.243			16'-11"	Pv
RN	2.1570	Q=51.32	4.51	C=120		0.022227	1'-0"	Pf 0.378
352	24'-0"			14.243		LtE(3'-8 1/4")	16'-0"	Pe 0.434
239	23'-0"			15.054		PO(12'-3 3/4")	17'-0"	Pv
CM	2.6350	Q=87.83	5.17	C=120		0.022657	9'-8 3/4"	Pf 0.221
239	23'-0"			15.054				Pe
306	23'-0"			15.275			9'-8 3/4"	Pv
<b>Route 34</b>								
CM	2.1570	Q=36.51	3.21	C=120		0.011837	27'-11"	Pf 0.709
292	24'-0"			13.867		T(12'-3 3/4")	32'-0"	Pe 0.434
216	23'-0"			15.010		2LtE(3'-8 1/4"), PO(12'-3 3/4")	59'-11"	Pv
CM	2.6350	Q=36.51	2.15	C=120		0.004466	10'-0"	Pf 0.045
216	23'-0"			15.010				Pe
239	23'-0"			15.054			10'-0"	Pv
<b>Route 35</b>								
CM	2.1570	Q=26.47	2.32	C=120		0.006529	45'-11"	Pf 0.404
279	23'-0"			11.212		PO(12'-3 3/4")	16'-0"	Pe -0.434
528	24'-0"			11.183		LtE(3'-8 1/4")	61'-11"	Pv
RN	2.1570	Q=26.47	2.32	C=120		0.006529	1'-0"	Pf 0.111
528	24'-0"			11.183		LtE(3'-8 1/4")	16'-0"	Pe 0.434
301	23'-0"			11.727		PO(12'-3 3/4")	17'-0"	Pv
<b>Route 36</b>								
CM	2.6350	Q=126.78	7.46	C=120		0.044676	10'-3"	Pf 0.458
279	23'-0"			11.212				Pe
253	23'-0"			11.670			10'-3"	Pv

# Hydraulic Analysis

Job Number: 2440 2nd Fl  
Report Description: Light Hazard

Pipe Type	Diameter	Flow	Velocity	HWC	Friction Loss	Length	Pressure
Downstream	Elevation	Discharge	K-Factor	Pt	Pn	Eq. Length	Summary
Upstream						Total Length	
CM	2.1570	Q=38.95	3.42	C=120	0.013340	45'-11"	Pf 0.826
253	23'-0"			11.670	PO(12'-3¾")	16'-0"	Pe -0.434
391	24'-0"			12.062	LtE(3'-8¼")	61'-11"	Pv
RN	2.1570	Q=38.95	3.42	C=120	0.013340	1'-0"	Pf 0.227
391	24'-0"			12.062	LtE(3'-8¼")	16'-0"	Pe 0.434
277	23'-0"			12.723	PO(12'-3¾")	17'-0"	Pv
***** Route 37 *****							
CM	2.6350	Q=87.83	5.17	C=120	0.022657	12'-11¾"	Pf 0.667
253	23'-0"			11.670		16'-5¾"	Pe
226	23'-0"			12.337	PO(16'-5¾")	29'-5½"	Pv
***** Route 38 *****							
CM	2.6350	Q=153.25	9.02	C=120	0.063448	11'-3½"	Pf 0.716
313	23'-0"			10.496			Pe
279	23'-0"			11.212		11'-3½"	Pv
***** Route 39 *****							
CM	2.1570	Q=9.38	0.82	C=120	0.000958	5'-8½"	Pf 0.017
863	24'-0"			7.481		12'-3¾"	Pe
861	24'-0"			7.499	PO(12'-3¾")	18'-0¼"	Pv
CM	2.6350	Q=9.38	0.55	C=120	0.000361	0'-11¼"	Pf 0.000
861	24'-0"			7.499			Pe
845	24'-0"			7.499		0'-11¼"	Pv
***** Route 40 *****							
CM	2.1570	Q=4.57	0.40	C=120	0.000254	8'-3¾"	Pf 0.006
641	24'-0"			9.265		16'-0"	Pe 0.434
393	23'-0"			9.705	LtE(3'-8¼"), PO(12'-3¾")	24'-3¾"	Pv
***** Route 41 *****							
CM	2.1570	Q=9.17	0.80	C=120	0.000918	12'-0"	Pf 0.011
682	24'-0"			8.296			Pe
680	24'-0"			8.307		12'-0"	Pv
***** Route 42 *****							
CM	2.1570	Q=8.56	0.75	C=120	0.000810	12'-0"	Pf 0.010
710	24'-0"			7.839			Pe
708	24'-0"			7.849		12'-0"	Pv
***** Route 43 *****							
CM	2.1570	Q=8.14	0.72	C=120	0.000738	5'-4½"	Pf 0.013
747	24'-0"			7.557		12'-3¾"	Pe
745	24'-0"			7.570	PO(12'-3¾")	17'-8¼"	Pv
***** Route 44 *****							
CM	2.1570	Q=8.99	0.79	C=120	0.000885	5'-4½"	Pf 0.016
779	24'-0"			7.498		12'-3¾"	Pe
777	24'-0"			7.514	PO(12'-3¾")	17'-8¼"	Pv

Equivalent Pipe Lengths of Valves and Fittings (C=120 only)

C Value Multiplier

$$\left( \frac{\text{Actual Inside Diameter}}{\text{Schedule 40 Steel Pipe Inside Diameter}} \right)^{4.87} = \text{Factor}$$

Value Of C	100	130	140	150
Multiplying Factor	0.713	1.16	1.33	1.51



# Hydraulic Analysis

Job Number: 2440 2nd Fl  
Report Description: Light Hazard

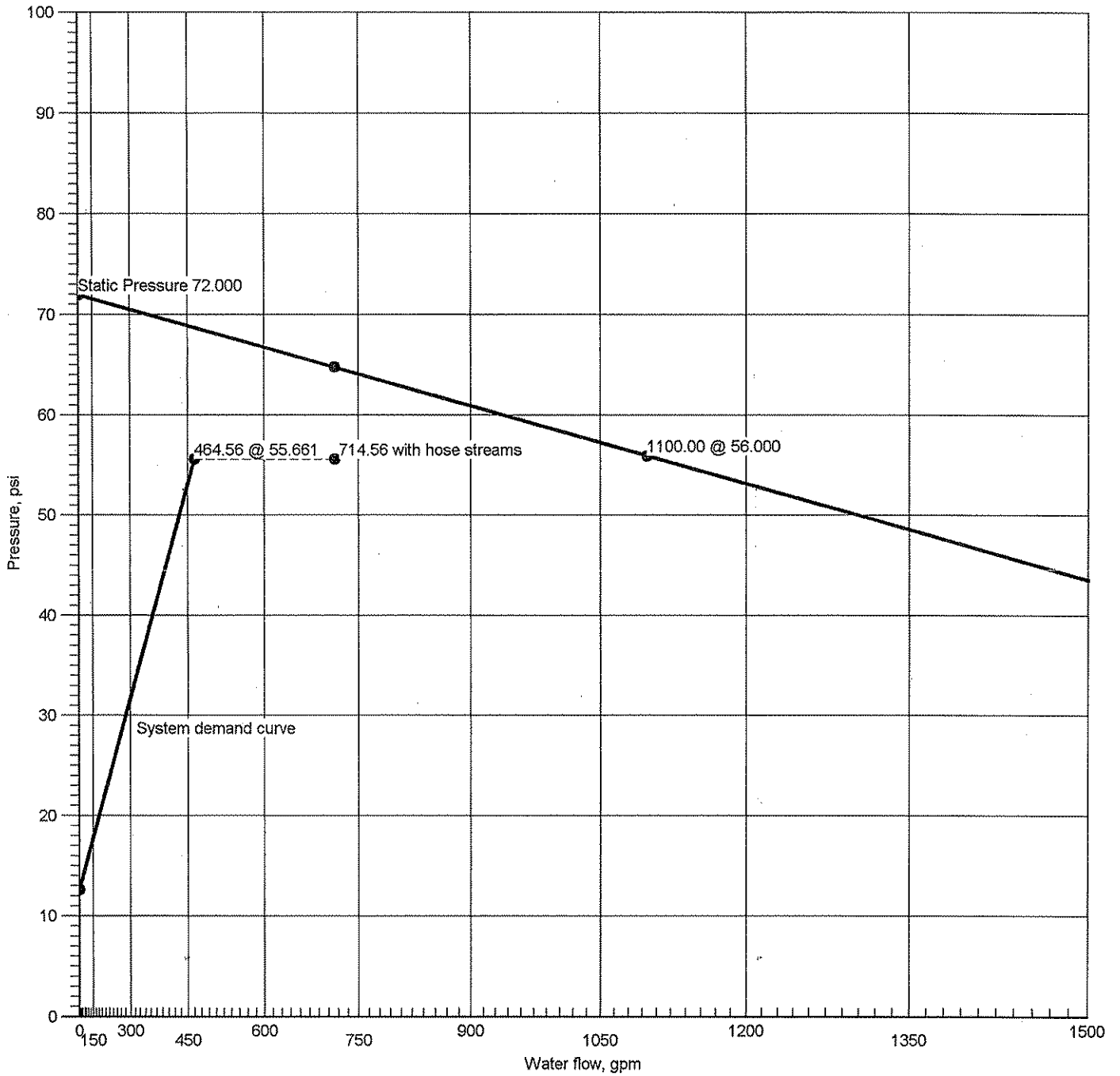
Pipe Type	Diameter	Flow	Velocity	HWC	Friction Loss	Length	Pressure
Downstream	Elevation	Discharge	K-Factor	Pt	Pn	Eq. Length	Summary
Upstream						Total Length	

Pipe Type Legend	
AO	Arm-Over
BL	Branch Line
CM	Cross Main
DN	Drain
DR	Drop
DY	Dynamic
FM	Feed Main
FR	Feed Riser
MS	Miscellaneous
OR	Outrigger
RN	Riser Nipple
SP	Sprig
ST	Stand Pipe
UG	Underground

Units Legend	
Diameter	Inch
Elevation	Foot
Flow	gpm
Discharge	gpm
Velocity	fps
Pressure	psi
Length	Foot
Friction Loss	psi/Foot
HWC	Hazen-Williams Constant
Pt	Total pressure at a point in a pipe
Pn	Normal pressure at a point in a pipe
Pf	Pressure loss due to friction between points
Pe	Pressure due to elevation difference between indicated points
Pv	Velocity pressure at a point in a pipe

Fittings Legend	
ALV	Alarm Valve
AngV	Angle Valve
b	Bushing
BalV	Ball Valve
BFP	Backflow Preventer
BV	Butterfly Valve
C	Cross Flow Turn 90°
cplg	Coupling
Cr	Cross Run
CV	Check Valve
DelV	Deluge Valve
DPV	Dry Pipe Valve
E	90° Elbow
EE	45° Elbow
Ee1	11¼° Elbow
Ee2	22½° Elbow
f	Flow Device
FDC	Fire Department Connection
fE	90° FireLock(TM) Elbow
fEE	45° FireLock(TM) Elbow
flg	Flange
FN	Floating Node
FT	FireLock(TM) Tee
g	Gauge
GloV	Globe Valve
GV	Gate Valve
Hose	Hose
HV	Hose Valve
Hyd	Hydrant
LtE	Long Turn Elbow
mecT	Mechanical Tee
Noz	Nozzle
P1	Pump In
P2	Pump Out
PIV	Post Indicating Valve
PO	Pipe Outlet
PrV	Pressure Relief Valve
PRV	Pressure Reducing Valve
red	Reducer/Adapter
S	Supply
sCV	Swing Check Valve
Spr	Sprinkler
St	Strainer
T	Tee Flow Turn 90°
Tr	Tee Run
U	Union
WirF	Wirsbo
WMV	Water Meter Valve
Z	Cap

### Supply at Node 1



Hydraulic Graph
Supply at Node 1
Static Pressure
72.000
Residual Pressure
1100.00 @ 56.000
Available Pressure/Time of Test
64.797 @ 714.56
System Demand
464.56 @ 55.661
System Demand (Including Hose Allowance)
714.56 @ 55.661



# Hydraulic Overview

Job Number: 269-941989101  
Report Description: Ordinary Group II

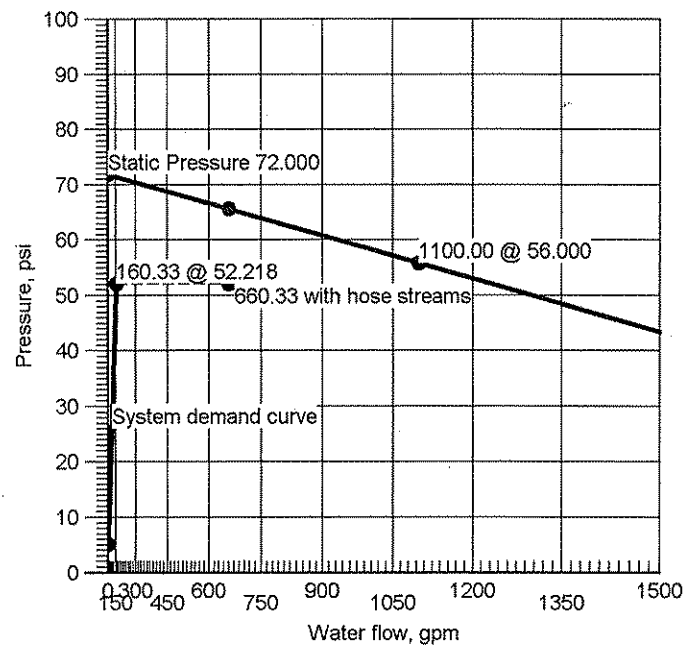
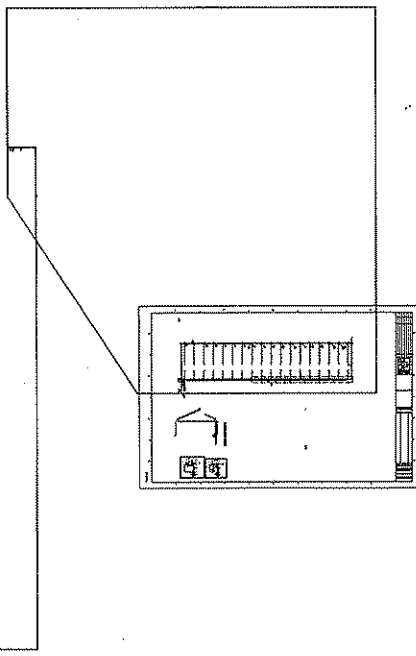
Job Number 269-941989101			Design Engineer		
Job Name STENNIS RIVERINE BLDG 2442 BOAT STORAGE PLATF			Phone		FAX
Address 1 PLATFORM IN BOAT STORAGE			State Certification/License Number		
Address 2 STENNIS SPACE CENTER			AHJ		
City STENNIS		State MS	Zip Code		Job Site DEMAND WITH 500 GPM HOSE ALLOWANCE

<b>System</b>	
Density 0.200gpm/ft <sup>2</sup>	Area of Application 632.00ft <sup>2</sup>
Most Demanding Sprinkler Data 5.6 K-Factor 18.00 at 10.332	Hose Streams 500.00
Coverage Per Sprinkler 90.00ft <sup>2</sup>	Number Of Sprinklers Calculated 7
System Pressure Demand 52.218	System Flow Demand 160.33
Total Demand 660.33 @ 52.218	Pressure Result +13.557 (20.6%)

Supplies					Check Point Gauges			
Node	Flow(gpm)	Hose Flow(gpm)	Static(psi)	Residual(psi)	Identifier	Pressure(psi)	K-Factor(K)	Flow(gpm)
1	1100.00	500.00	72.000	56.000	BOR	0.000	0	0.00
					BOR	0.000	0	0.00

FP-2 BLDG 2442 R5

Supply at Node 1 (1100.00, 500.00, 72.000, 56.000)







# Summary Of Outflowing Devices

Device		Actual Flow (gpm)	Minimum Flow (gpm)	K-Factor (K)	Pressure (psi)		
Sprinkler	207	27.54	18.00	5.6	24.189		
Sprinkler	206	26.21	18.00	5.6	21.909		
Sprinkler	205	25.35	18.00	5.6	20.485		
Sprinkler	204	23.26	18.00	5.6	17.246		
Sprinkler	203	20.63	18.00	5.6	13.568		
Sprinkler	202	19.35	18.00	5.6	11.938		
⇒ Sprinkler	201	18.00	18.00	5.6	10.332		

⇒ Most Demanding Sprinkler Data



# Node Analysis

Node	Elevation(Foot)	Fittings	Pressure(psi)	Discharge(gpm)
5	-5'-0	2T(52'-9¾)	39.590	
7	-5'-0	LtE(19'-7½)	39.595	
9	-6'-0	LtE(22'-0¾)	52.043	
93	19'-2		25.951	
94	19'-2		25.941	
95	19'-2		25.930	
96	19'-2		25.919	
99	19'-2		25.887	
100	19'-2		25.876	
155	19'-2		25.844	
158	18'-9¼	PO(12'-3¾)	26.138	
159	18'-9¼	PO(12'-3¾)	26.137	
160	18'-9¼	PO(12'-3¾)	26.135	
161	18'-9¼	PO(12'-3¾)	26.134	
162	18'-9¼	PO(12'-3¾)	26.132	
147	18'-9¼	PO(12'-3¾)	26.131	
148	18'-9¼	PO(12'-3¾)	26.129	
146	18'-9¼		26.128	
116	18'-9¼	PO(12'-3¾)	26.083	
117	18'-9¼	PO(12'-3¾)	26.072	
120	18'-9¼	PO(12'-3¾)	26.040	
121	18'-9¼	PO(12'-3¾)	26.030	
316	18'-9¼	C(26'-4), C(37'-8¾)	26.150	
330	18'-9¼	PO(12'-3¾)	25.826	
352	6'-0	2T(12'-3¾)	24.336	
363	6'-0		20.664	
14	1'-0		36.930	
332	3'-3	BV(12'-7)	35.957	
338	18'-9¼	LtE(11'-3¾)	26.163	
16	-5'-0	T(59'-4½)	39.552	
454	-4'-10		0.000	
207	6'-0	Spr(-24.189)	24.189	27.54
206	6'-0	Spr(-21.909)	21.909	26.21
205	6'-0	Spr(-20.485)	20.485	25.35
204	6'-0	Spr(-17.246)	17.246	23.26
203	6'-0	Spr(-13.568)	13.568	20.63
202	6'-0	Spr(-11.938)	11.938	19.35
201	6'-0	Spr(-10.332)	10.332	18.00
1	-6'-0	S	52.218	160.33

# Hydraulic Analysis

Job Number: 269-941989101  
Report Description: Ordinary Group II

Pipe Type	Diameter	Flow	Velocity	HWC	Friction Loss	Length	Pressure
Downstream	Elevation	Discharge	K-Factor	Pt	Pn	Eq. Length	Summary
Upstream					Fittings	Total Length	
<b>Route 1</b>							
BL	1.0490	Q=18.00	6.68	C=120	0.107085	15'-0"	Pf 1.606
201	6'-0"	q=18.00	K=5.6	10.332	Spr(-10.332)		Pe
202	6'-0"			11.938		15'-0"	Pv
BL	1.3800	Q=37.35	8.01	C=120	0.108681	15'-0"	Pf 1.630
202	6'-0"	q=19.35	K=5.6	11.938	Spr(-11.938)		Pe
203	6'-0"			13.568		15'-0"	Pv
BL	1.3800	Q=57.98	12.44	C=120	0.245163	15'-0"	Pf 3.677
203	6'-0"	q=20.63	K=5.6	13.568	Spr(-13.568)		Pe
204	6'-0"			17.246		15'-0"	Pv
BL	1.6100	Q=81.23	12.80	C=120	0.215976	15'-0"	Pf 3.240
204	6'-0"	q=23.26	K=5.6	17.246	Spr(-17.246)		Pe
205	6'-0"			20.485		15'-0"	Pv
BL	1.6100	Q=106.58	16.80	C=120	0.356939	0'-6"	Pf 0.178
205	6'-0"	q=25.35	K=5.6	20.485	Spr(-20.485)		Pe
363	6'-0"			20.664		0'-6"	Pv
CM	2.1570	Q=106.58	9.36	C=120	0.085899	14'-6"	Pf 1.246
363	6'-0"			20.664			Pe
206	6'-0"			21.909		14'-6"	Pv
CM	2.1570	Q=132.79	11.66	C=120	0.129020	6'-6"	Pf 2.426
206	6'-0"	q=26.21	K=5.6	21.909	Spr(-21.909)	12'-3/4"	Pe
352	6'-0"			24.336	T(12'-3/4")	18'-9/4"	Pv
CM	2.1570	Q=160.33	14.08	C=120	0.182848	18'-8/4"	Pf 7.025
352	6'-0"			24.336		19'-8/4"	Pe -5.535
330	18'-9/4"			25.826	2LiE(3'-8/4"), PO(12'-3/4")	38'-5"	Pv
CM	4.2600	Q=100.57	2.26	C=120	0.002806	89'-3/2"	Pf 0.324
330	18'-9/4"			25.826		26'-4"	Pe -0.000
316	18'-9/4"			26.150	C(26'-4")	115'-7/2"	Pv
CM	6.3570	Q=160.33	1.62	C=120	0.000946	1'-8"	Pf 0.012
316	18'-9/4"			26.150		11'-3/4"	Pe -0.000
338	18'-9/4"			26.163	LiE(11'-3/4")	13'-0"	Pv
FR	6.3570	Q=160.33	1.62	C=120	0.000946	13'-8/4"	Pf 3.063
338	18'-9/4"			26.163		52'-9/4"	Pe 6.731
332	3'-3"			35.957	f(-3.000), CV(40'-2/4"), BV(12'-7")	66'-6"	Pv
FR	6.0650	Q=160.33	1.78	C=120	0.001190	2'-0"	Pf 0.002
332	3'-3"			35.957			Pe 0.971
14	1'-0"			36.930		2'-0"	Pv
UG	8.3900	Q=160.33	0.93	C=140	0.000184	19'-3/2"	Pf 0.020
14	1'-0"			36.930		89'-11"	Pe 2.601
16	-5'-0"			39.552	E(30'-6/4"), T(59'-4/4")	109'-2/2"	Pv
UG	7.9800	Q=103.31	0.66	C=150	0.000092	340'-11/4"	Pf 0.039
16	-5'-0"			39.552		79'-11/4"	Pe
5	-5'-0"			39.590	2EE(13'-7"), T(52'-9/4")	420'-11/4"	Pv
UG	7.9800	Q=160.33	1.03	C=150	0.000207	1'-11"	Pf 0.004
5	-5'-0"			39.590		19'-7/2"	Pe
7	-5'-0"			39.595	LiE(19'-7/2")	21'-6/2"	Pv
UG	8.3900	Q=160.33	0.93	C=140	0.000184	17'-0"	Pf 12.015
7	-5'-0"			39.595		66'-2"	Pe 0.434
9	-6'-0"			52.043	3LiE(22'-0/4"), BFP(-12.000)	83'-2"	Pv
UG	7.9800	Q=160.33	1.03	C=150	0.000207	726'-3/2"	Pf 0.175
9	-6'-0"			52.043		119'-2/2"	Pe
1	-6'-0"			52.218	2E(27'-2), 2GV(6'-0/2), T(52'-9/4"), S	845'-6/4"	Pv
<b>Route 2</b>							
CM	2.1570	Q=27.54	2.42	C=120	0.007028	8'-6"	Pf 0.146
207	6'-0"	q=27.54	K=5.6	24.189	Spr(-24.189)	12'-3/4"	Pe
352	6'-0"			24.336	T(12'-3/4")	20'-9/4"	Pv
<b>Route 3</b>							
CM	6.3570	Q=59.76	0.60	C=120	0.000152	7'-9"	Pf 0.001
146	18'-9/4"			26.128			Pe -0.000
148	18'-9/4"			26.129		7'-9"	Pv
CM	6.3570	Q=59.76	0.60	C=120	0.000152	10'-0"	Pf 0.002
148	18'-9/4"			26.129			Pe -0.000
147	18'-9/4"			26.131		10'-0"	Pv
CM	6.3570	Q=59.76	0.60	C=120	0.000152	10'-0"	Pf 0.002
147	18'-9/4"			26.131			Pe -0.000
162	18'-9/4"			26.132		10'-0"	Pv
CM	6.3570	Q=59.76	0.60	C=120	0.000152	10'-0"	Pf 0.002
162	18'-9/4"			26.132			Pe -0.000
161	18'-9/4"			26.134		10'-0"	Pv
CM	6.3570	Q=59.76	0.60	C=120	0.000152	10'-0"	Pf 0.002
161	18'-9/4"			26.134			Pe -0.000
160	18'-9/4"			26.135		10'-0"	Pv



# Hydraulic Analysis

Job Number: 269-941989101  
Report Description: Ordinary Group II

Pipe Type	Diameter	Flow	Velocity	HWC	Friction Loss	Length	Pressure
Downstream	Elevation	Discharge	K-Factor	Pt	Pn	Eq. Length	Summary
Upstream					Fittings	Total Length	
CM	6.3570	Q=59.76	0.60	C=120	0.000152	10'-0"	Pf 0.002
160	18'-9¼"			26.135			Pe 0.000
159	18'-9¼"			26.137		10'-0"	Pv
CM	6.3570	Q=59.76	0.60	C=120	0.000152	10'-0"	Pf 0.002
159	18'-9¼"			26.137			Pe -0.000
158	18'-9¼"			26.138		10'-0"	Pv
CM	6.3570	Q=59.76	0.60	C=120	0.000152	40'-0½"	Pf 0.012
158	18'-9¼"			26.138		37'-8¾"	Pe -0.000
316	18'-9¼"			26.150	T(37'-8¾")	77'-9"	Pv
<b>Route 4</b>							
UG	7.9800	Q=57.03	0.37	C=150	0.000031	1129'-3½"	Pf 0.039
16	-5'-0"			39.552		134'-3¾"	Pe
5	-5'-0"			39.590	3E(27'-2), T(52'-9¾")	1263'-7¼"	Pv
<b>Route 5</b>							
CM	4.2600	Q=59.76	1.35	C=120	0.001071	10'-0"	Pf 0.011
121	18'-9¼"			26.030			Pe -0.000
120	18'-9¼"			26.040		10'-0"	Pv
CM	4.2600	Q=59.76	1.35	C=120	0.001071	30'-0"	Pf 0.032
120	18'-9¼"			26.040			Pe 0.000
117	18'-9¼"			26.072		30'-0"	Pv
CM	4.2600	Q=59.76	1.35	C=120	0.001071	10'-0"	Pf 0.011
117	18'-9¼"			26.072			Pe -0.000
116	18'-9¼"			26.083		10'-0"	Pv
CM	4.2600	Q=59.76	1.35	C=120	0.001071	42'-1"	Pf 0.045
116	18'-9¼"			26.083			Pe -0.000
146	18'-9¼"			26.128		42'-1"	Pv
<b>Route 6</b>							
CM	4.2600	Q=59.76	1.35	C=120	0.001071	137'-5"	Pf 0.204
330	18'-9¼"			25.826		52'-8"	Pe -0.000
121	18'-9¼"			26.030	2T(26'-4)	190'-1"	Pv

### Equivalent Pipe Lengths of Valves and Fittings (C=120 only)

$$\left( \frac{\text{Actual Inside Diameter}}{\text{Schedule 40 Steel Pipe Inside Diameter}} \right)^{4.87} = \text{Factor}$$

### C Value Multiplier

Value Of C	100	130	140	150
Multiplying Factor	0.713	1.16	1.33	1.51

# Hydraulic Analysis

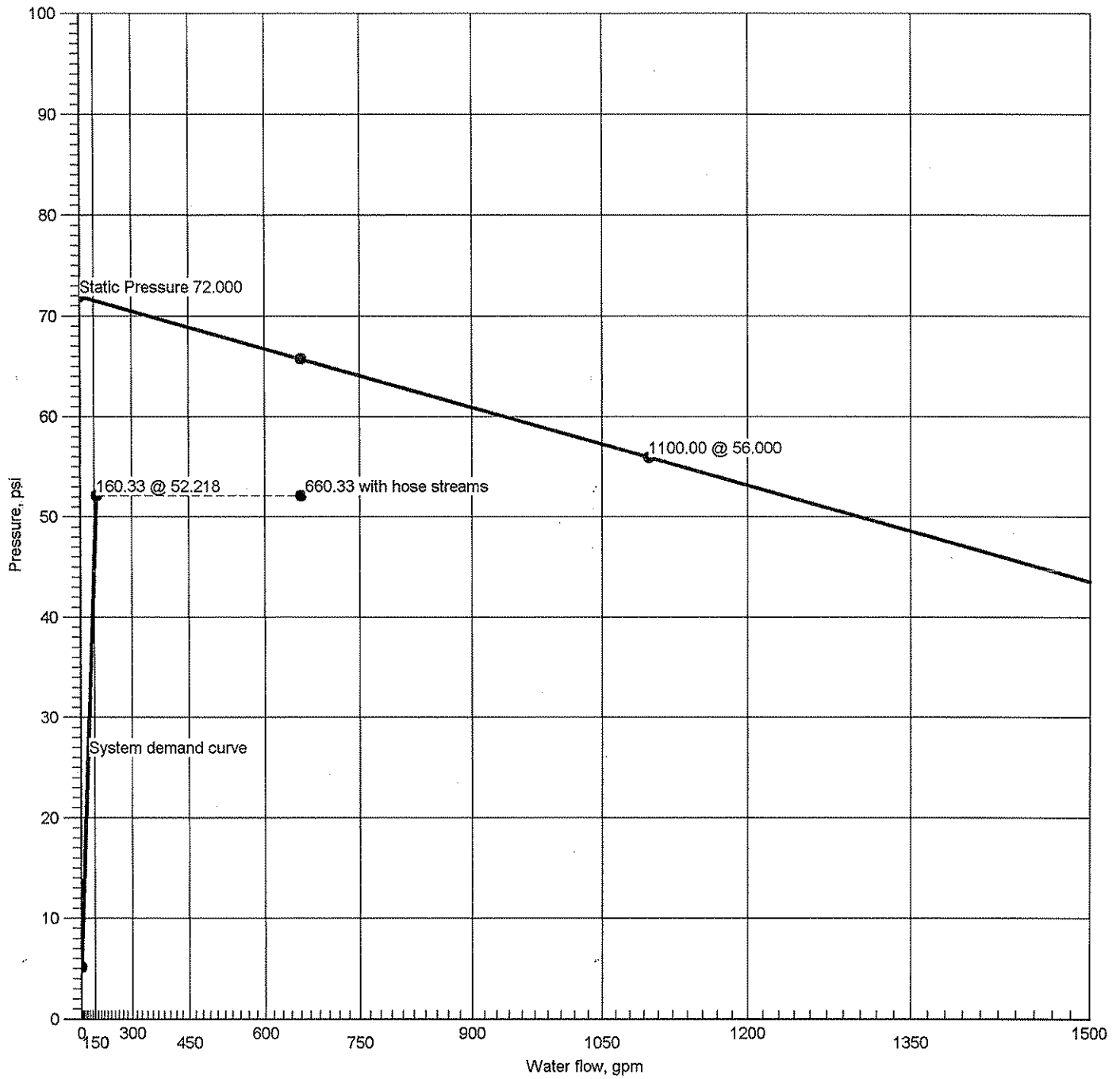
Job Number: 269-941989101  
 Report Description: Ordinary Group II

Pipe Type	Diameter	Flow	Velocity	HWC	Friction Loss		Length	Pressure
Downstream	Elevation	Discharge	K-Factor	Pt	Pn	Fittings	Eq. Length	Summary
Upstream							Total Length	

Pipe Type Legend		Units Legend		Fittings Legend	
AO	Arm-Over	Diameter	Inch	ALV	Alarm Valve
BL	Branch Line	Elevation	Foot	AngV	Angle Valve
CM	Cross Main	Flow	gpm	b	Bushing
DN	Drain	Discharge	gpm	BalV	Ball Valve
DR	Drop	Velocity	fps	BFP	Backflow Preventer
DY	Dynamic	Pressure	psi	BV	Butterfly Valve
FM	Feed Main	Length	Foot	C	Cross Flow Turn 90°
FR	Feed Riser	Friction Loss	psi/Foot	oplg	Coupling
MS	Miscellaneous	HWC	Hazen-Williams Constant	Cr	Cross Run
OR	Outrigger	Pt	Total pressure at a point in a pipe	CV	Check Valve
RN	Riser Nipple	Pn	Normal pressure at a point in a pipe	DelV	Deluge Valve
SP	Sprig	Pf	Pressure loss due to friction between points	DPV	Dry Pipe Valve
ST	Stand Pipe	Pe	Pressure due to elevation difference between indicated points	E	90° Elbow
UG	Underground	Pv	Velocity pressure at a point in a pipe	EE	45° Elbow
				Ee1	11¼° Elbow
				Ee2	22½° Elbow
				f	Flow Device
				FDC	Fire Department Connection
				fE	90° FireLock(TM) Elbow
				fEE	45° FireLock(TM) Elbow
				flg	Flange
				FN	Floating Node
				FT	FireLock(TM) Tee
				g	Gauge
				GloV	Globe Valve
				GV	Gate Valve
				Hose	Hose
				HV	Hose Valve
				Hyd	Hydrant
				LtE	Long Turn Elbow
				mecT	Mechanical Tee
				Noz	Nozzle
				P1	Pump In
				P2	Pump Out
				PIV	Post Indicating Valve
				PO	Pipe Outlet
				PrV	Pressure Relief Valve
				PRV	Pressure Reducing Valve
				red	Reducer/Adapter
				S	Supply
				sCV	Swing Check Valve
				Spr	Sprinkler
				St	Strainer
				T	Tee Flow Turn 90°
				Tr	Tee Run
				U	Union
				WirF	Wirsbo
				WMV	Water Meter Valve
				Z	Cap

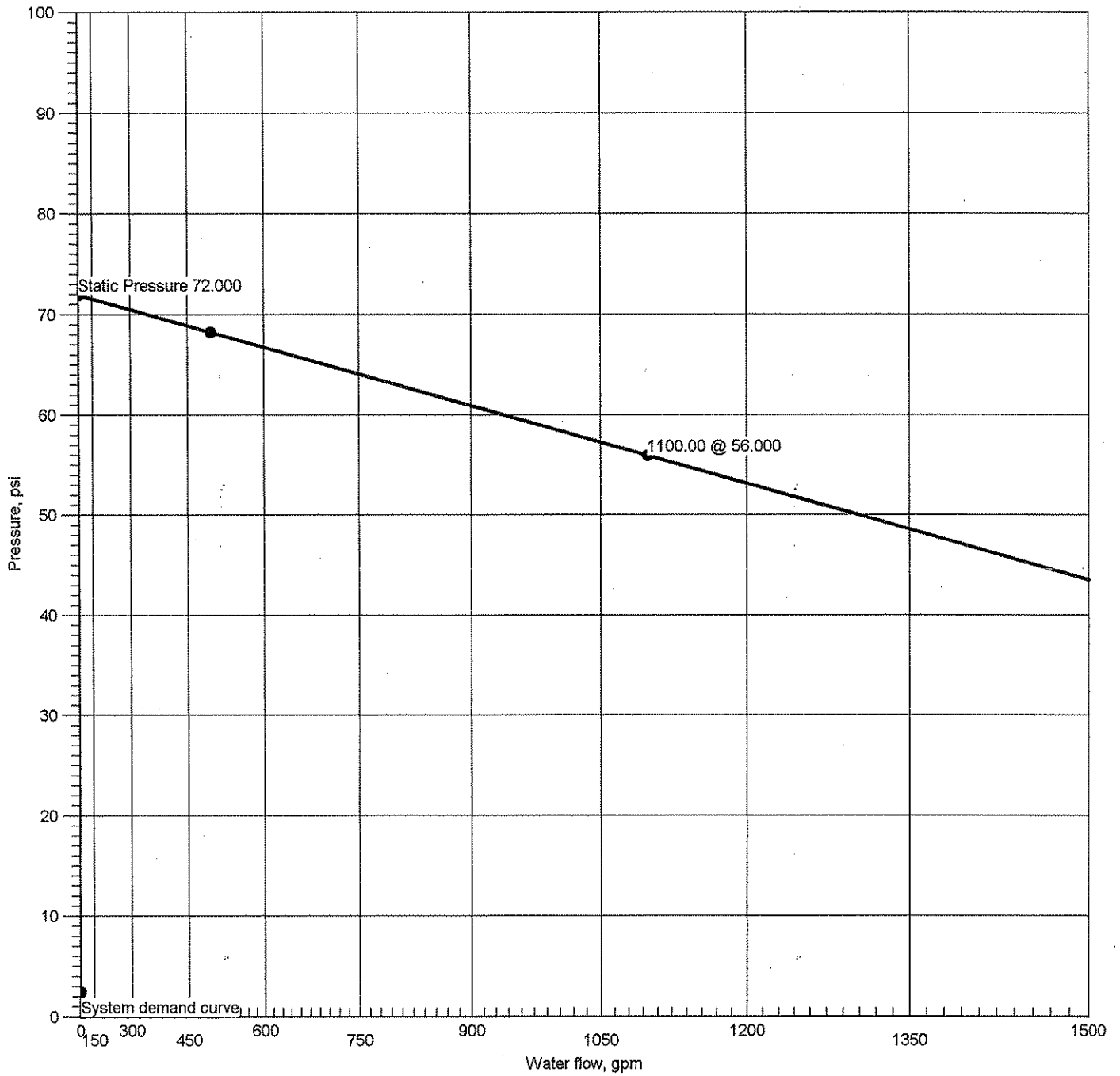


### Supply at Node 1



Hydraulic Graph
Supply at Node 1
Static Pressure 72.000
Residual Pressure 1100.00 @ 56.000
Available Pressure/Time of Test 65.776 @ 660.33
System Demand 160.33 @ 52.218
System Demand (including Hose Allowance) 660.33 @ 52.218

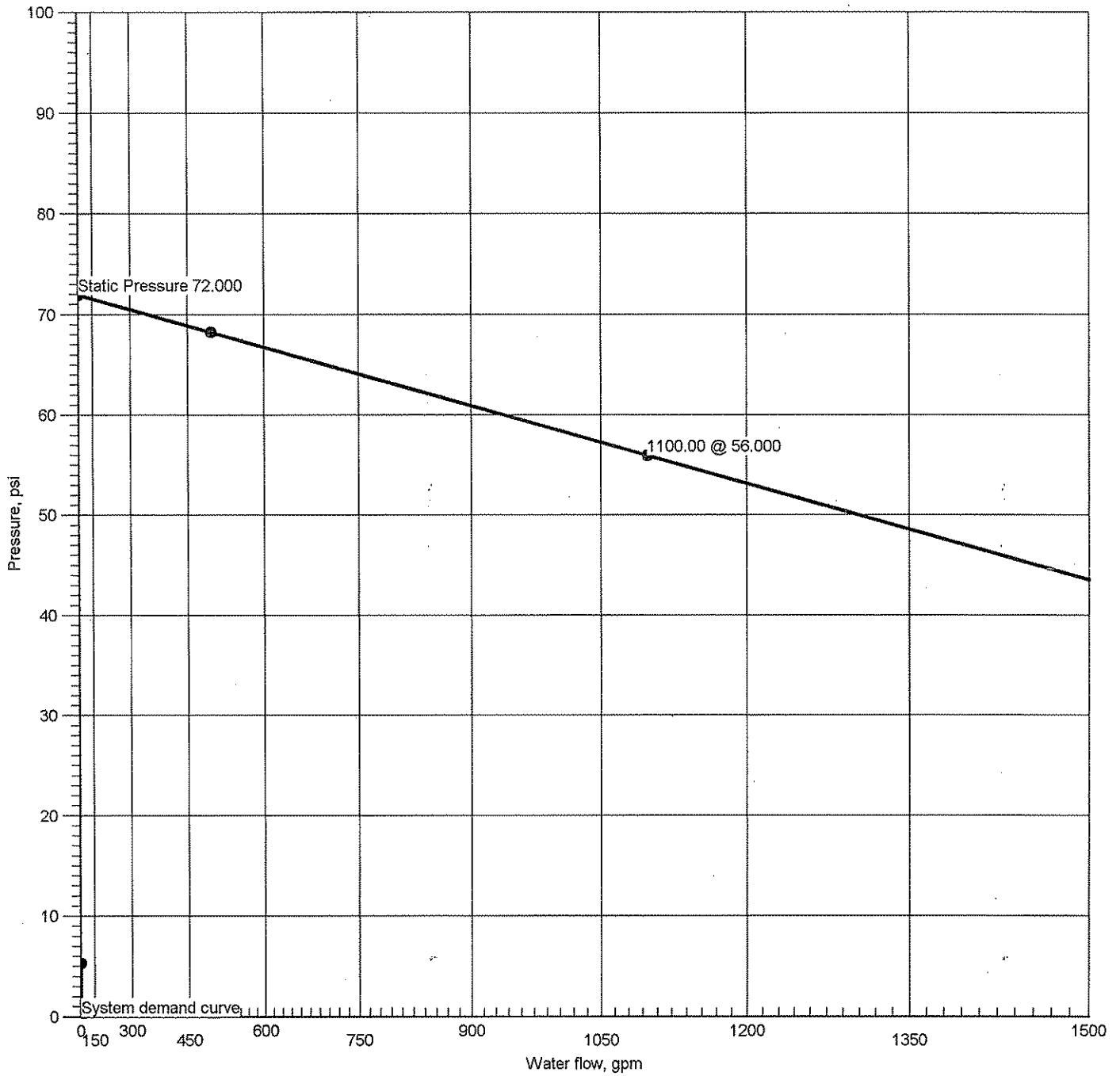
# BOR



Hydraulic Graph
BOR
Static Pressure
N/A
Residual Pressure
N/A
Available Pressure/Time of Test
13.557 @ 0.00
System Demand
0.00 @ 0.000
System Demand (Including Hose Allowance)
N/A @ 0.000



# BOR



Hydraulic Graph
BOR
Static Pressure
N/A
Residual Pressure
N/A
Available Pressure/Time of Test
13.557 @ 0.00
System Demand
0.00 @ 0.000
System Demand (including Hose Allowance)
N/A @ 0.000



# Hydraulic Overview

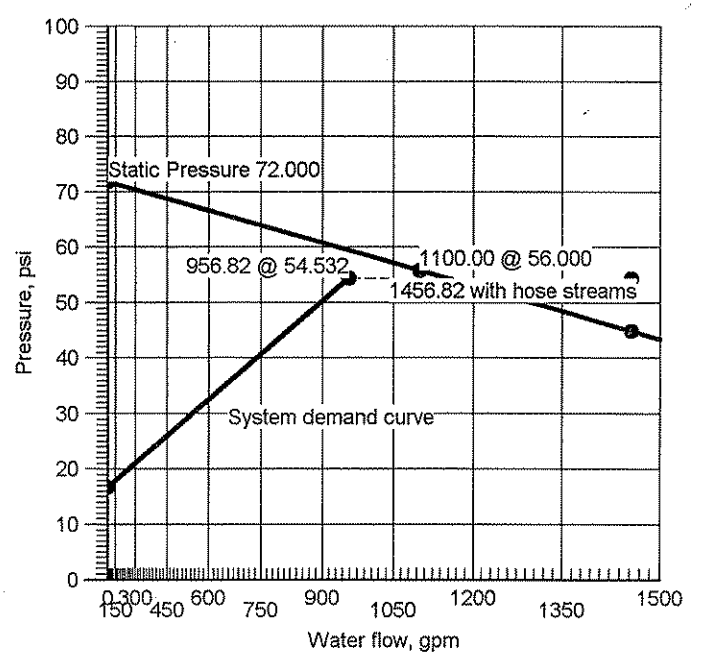
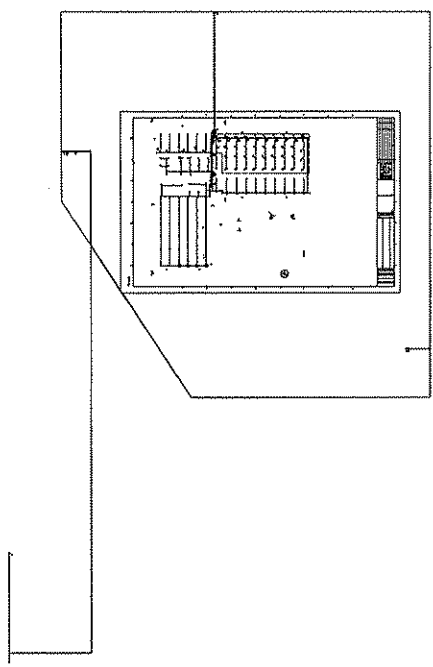
Job Number: 2441 MAINT  
Report Description: Ordinary Group II

Job Number <b>2441 MAINT</b>			Design Engineer		
Job Name <b>STENNIS RIVERINE BLDG 2441 BOAT MAINTENANCE</b>			Phone	FAX	
Address 1 <b>MAINTENANCE BLDG</b>			State Certification/License Number		
Address 2 <b>STENNIS SPACE CENTER</b>			AHJ		
City <b>STENNIS</b>	State <b>MS</b>	Zip Code	Job Site <b>DEMAND WITH 500 GPM HOSE ALLOWANCE</b>		

<b>System</b>	
Density 0.200gpm/ft <sup>2</sup>	Area of Application 3900.00ft <sup>2</sup> (Actual 3915.38ft <sup>2</sup> )
Most Demanding Sprinkler Data 8 K-Factor 21.17 at 7.000	Hose Streams 500.00
Coverage Per Sprinkler 104.17ft <sup>2</sup>	Number Of Sprinklers Calculated 38
System Pressure Demand 54.532	System Flow Demand 956.82
Total Demand 1456.82 @ 54.532	Pressure Result -9.437 (-17.3%)

<b>Supplies</b>					<b>Check Point Gauges</b>			
Node	Flow(gpm)	Hose Flow(gpm)	Static(psi)	Residual(psi)	Identifier	Pressure(psi)	K-Factor(K)	Flow(gpm)
1	1100.00	500.00	72.000	56.000				

FP-3 BLDG 2440 2441 1st Floor R5 Supply at Node 1 (1100.00, 500.00, 72.000, 56.000)





# Summary Of Outflowing Devices

Device		Actual Flow (gpm)	Minimum Flow (gpm)	K-Factor (K)	Pressure (psi)		
Sprinkler	338	31.42	24.70	8	15.423		
Sprinkler	336	29.30	20.87	8	13.418		
Sprinkler	332	28.73	20.87	8	12.900		
Sprinkler	328	28.34	20.87	8	12.553		
Sprinkler	324	28.11	20.87	8	12.342		
Sprinkler	320	27.98	20.87	8	12.235		
Sprinkler	312	27.94	20.87	8	12.198		
Sprinkler	304	27.94	20.87	8	12.196		
Sprinkler	308	27.95	20.87	8	12.209		
Sprinkler	316	28.03	20.87	8	12.273		
Sprinkler	337	29.75	24.70	8	13.825		
Sprinkler	335	27.03	20.87	8	11.420		
Sprinkler	331	26.44	20.87	8	10.925		
Sprinkler	327	26.04	20.87	8	10.593		
Sprinkler	323	25.79	20.87	8	10.391		
Sprinkler	319	25.66	20.87	8	10.289		
Sprinkler	311	25.62	20.87	8	10.254		
Sprinkler	802	25.61	20.87	8	10.252		
Sprinkler	307	25.63	20.87	8	10.264		
Sprinkler	315	25.71	20.87	8	10.325		
Sprinkler	334	24.91	20.87	8	9.698		
Sprinkler	330	24.28	20.87	8	9.214		
Sprinkler	326	23.85	20.87	8	8.889		
Sprinkler	322	23.59	20.87	8	8.692		
Sprinkler	318	23.45	20.87	8	8.592		
Sprinkler	310	23.40	20.87	8	8.558		
Sprinkler	302	23.40	20.87	8	8.556		
Sprinkler	306	23.42	20.87	8	8.567		
Sprinkler	314	23.50	20.87	8	8.627		
Sprinkler	333	22.82	20.87	8	8.135		
Sprinkler	329	22.13	20.87	8	7.654		
Sprinkler	325	21.66	20.87	8	7.331		
Sprinkler	321	21.37	20.87	8	7.136		
Sprinkler	317	21.22	20.87	8	7.036		
Sprinkler	309	21.17	20.87	8	7.002		
⇒ Sprinkler	301	21.17	20.87	8	7.000		
Sprinkler	305	21.18	20.87	8	7.012		
Sprinkler	806	21.27	20.87	8	7.071		

⇒ Most Demanding Sprinkler Data



# Node Analysis

Node	Elevation(Foot)	Fittings	Pressure(psi)	Discharge(gpm)
3	-5'-0	T(59'-4½)	35.787	
7	1'-0		32.055	
84	4'-0¼	CV(16'-0)	30.361	
161	8'-3		26.721	
163	15'-0	LiE(11'-3¾)	23.621	
141	22'-0	LiE(3'-8¼)	15.675	
142	22'-0	LiE(3'-8¼)	13.747	
143	22'-0	LiE(3'-8¼)	13.224	
144	22'-0	LiE(3'-8¼)	12.873	
145	22'-0	LiE(3'-8¼)	12.660	
146	22'-0	LiE(3'-8¼)	12.552	
147	22'-0	LiE(3'-8¼)	12.515	
148	22'-0	LiE(3'-8¼)	12.513	
149	22'-0	LiE(3'-8¼)	12.526	
150	22'-0	LiE(3'-8¼)	12.590	
261	15'-0	T(37'-8¾)	22.927	
262	17'-8		21.203	
123	18'-3	PO(12'-3¾)	17.917	
124	18'-3	PO(12'-3¾)	17.016	
125	18'-3	PO(12'-3¾)	16.421	
126	18'-3	PO(12'-3¾)	16.022	
127	18'-3	PO(12'-3¾)	15.780	
128	18'-3	PO(12'-3¾)	15.657	
129	18'-3	PO(12'-3¾)	15.615	
130	18'-3	PO(12'-3¾)	15.612	
131	18'-3	PO(12'-3¾)	15.627	
132	18'-3	PO(12'-3¾)	15.700	
284	15'-0		22.927	
5	-5'-0	2T(52'-9¾)	36.787	
11	-5'-0	LiE(19'-7½)	36.908	
12	-6'-0	LiE(22'-0¾)	49.759	
164	8'-4	PO(6'-0)	0.000	
166	8'-4	PO(6'-0)	0.000	
168	8'-4	PO(6'-0)	0.000	
170	8'-4	PO(6'-0)	0.000	
173	8'-4	PO(6'-0)	0.000	
175	8'-4	PO(6'-0)	0.000	
358	8'-4	PO(5'-0)	25.563	
198	15'-0	PO(16'-5¾)	22.676	
479	7'-10	T(5'-0)	25.461	
480	10'-7¾	PO(5'-0)	24.241	
482	10'-7¾		24.241	
297	15'-0	PO(20'-2)	22.354	
530	10'-0	PO(5'-0)	24.301	
313	15'-0	T(26'-4)	22.133	
338	22'-5¾	Spr(-15.423)	15.423	31.42
336	22'-5¾	Spr(-13.418)	13.418	29.30
332	22'-5¾	Spr(-12.900)	12.900	28.73
328	22'-5¾	Spr(-12.553)	12.553	28.34
324	22'-5¾	Spr(-12.342)	12.342	28.11
320	22'-5¾	Spr(-12.235)	12.235	27.98
312	22'-5¾	Spr(-12.198)	12.198	27.94
304	22'-5¾	Spr(-12.196)	12.196	27.94
308	22'-5¾	Spr(-12.209)	12.209	27.95
316	22'-5¾	Spr(-12.273)	12.273	28.03
337	25'-11½	Spr(-13.825)	13.825	29.75
335	25'-11½	Spr(-11.420)	11.420	27.03
331	25'-11½	Spr(-10.925)	10.925	26.44
327	25'-11½	Spr(-10.593)	10.593	26.04
323	25'-11½	Spr(-10.391)	10.391	25.79
319	25'-11½	Spr(-10.289)	10.289	25.66
311	25'-11½	Spr(-10.254)	10.254	25.62
802	25'-11½	Spr(-10.252)	10.252	25.61
307	25'-11½	Spr(-10.264)	10.264	25.63
315	25'-11½	Spr(-10.325)	10.325	25.71
334	29'-5¼	Spr(-9.698)	9.698	24.91
330	29'-5¼	Spr(-9.214)	9.214	24.28
326	29'-5¼	Spr(-8.889)	8.889	23.85
322	29'-5¼	Spr(-8.692)	8.692	23.59
318	29'-5¼	Spr(-8.592)	8.592	23.45
310	29'-5¼	Spr(-8.558)	8.558	23.40
302	29'-5¼	Spr(-8.556)	8.556	23.40
306	29'-5¼	Spr(-8.567)	8.567	23.42
314	29'-5¼	Spr(-8.627)	8.627	23.50
333	32'-11	Spr(-8.135)	8.135	22.82
329	32'-11	Spr(-7.654)	7.654	22.13
325	32'-11	Spr(-7.331)	7.331	21.66



# Node Analysis

Job Number: 2441 MAINT  
Report Description: Ordinary Group II

Node	Elevation(foot)	Fittings	Pressure(psi)	Discharge(gpm)
321	32'-11	Spr(-7.136)	7.136	21.37
317	32'-11	Spr(-7.036)	7.036	21.22
309	32'-11	Spr(-7.002)	7.002	21.17
301	32'-11	Spr(-7.000)	7.000	21.17
305	32'-11	Spr(-7.012)	7.012	21.18
806	32'-11	Spr(-7.071)	7.071	21.27
1	-6'-0	S	54.532	956.82



# Hydraulic Analysis

Job Number: 2441 MAINT  
Report Description: Ordinary Group II

Pipe Type	Diameter	Flow	Velocity	HWC	Friction Loss	Length	Pressure
Downstream	Elevation	Discharge	K-Factor	Pt	Pn	Eq. Length	Summary
Upstream						Total Length	
<b>Route 1</b>							
CM	2.1570	Q=21.17	1.86	C=120	0.004318	11'-0"	Pf 0.047
301	32'-11"	q=21.17	K=8	7.000	Spr(-7.000)		Pe 1.508
302	29'-5 1/4"			8.556		11'-0"	Pv
CM	2.1570	Q=44.57	3.91	C=120	0.017118	11'-0"	Pf 0.188
302	29'-5 1/4"	q=23.40	K=8	8.556	Spr(-8.556)		Pe 1.508
802	25'-11 1/2"			10.252		11'-0"	Pv
CM	2.1570	Q=70.18	6.16	C=120	0.039656	11'-0"	Pf 0.436
802	25'-11 1/2"	q=25.61	K=8	10.252	Spr(-10.252)		Pe 1.508
304	22'-5 3/4"			12.196		11'-0"	Pv
CM	2.1570	Q=98.12	8.61	C=120	0.073713	1'-6"	Pf 0.111
304	22'-5 3/4"	q=27.94	K=8	12.196	Spr(-12.196)		Pe 0.206
148	22'-0"			12.513		1'-6"	Pv
RN	2.1570	Q=98.12	8.61	C=120	0.073713	3'-11 1/2"	Pf 1.471
148	22'-0"			12.513	LtE(3'-8 1/4")	16'-0"	Pe 1.628
130	18'-3"			15.612	PO(12'-3 3/4")	19'-11 1/2"	Pv
CM	4.2600	Q=27.27	0.61	C=120	0.000251	10'-0"	Pf 0.003
130	18'-3"			15.612			Pe
129	18'-3"			15.615		10'-0"	Pv
CM	4.2600	Q=125.40	2.82	C=120	0.004219	10'-0"	Pf 0.042
129	18'-3"			15.615			Pe
128	18'-3"			15.657		10'-0"	Pv
CM	4.2600	Q=223.71	5.04	C=120	0.012313	10'-0"	Pf 0.123
128	18'-3"			15.657			Pe
127	18'-3"			15.780		10'-0"	Pv
CM	4.2600	Q=322.56	7.26	C=120	0.024230	10'-0"	Pf 0.242
127	18'-3"			15.780			Pe
126	18'-3"			16.022		10'-0"	Pv
CM	4.2600	Q=422.45	9.51	C=120	0.039913	10'-0"	Pf 0.399
126	18'-3"			16.022			Pe
125	18'-3"			16.421		10'-0"	Pv
CM	4.2600	Q=524.04	11.80	C=120	0.059465	10'-0"	Pf 0.595
125	18'-3"			16.421			Pe
124	18'-3"			17.016		10'-0"	Pv
CM	4.2600	Q=628.11	14.14	C=120	0.083138	10'-10"	Pf 0.901
124	18'-3"			17.016			Pe
123	18'-3"			17.917		10'-10"	Pv
CM	4.2600	Q=689.28	15.52	C=120	0.098732	4'-4 3/4"	Pf 3.034
123	18'-3"			17.917		26'-4"	Pe 0.253
262	17'-8"			21.203	T(26'-4")	30'-8 3/4"	Pv
CM	6.3570	Q=689.28	6.97	C=120	0.014055	2'-8"	Pf 0.568
262	17'-8"			21.203		37'-8 3/4"	Pe 1.156
261	15'-0"			22.927	T(37'-8 3/4")	40'-4 3/4"	Pv
CM	6.3570	Q=956.82	9.67	C=120	0.025784	4'-3 1/2"	Pf 0.694
261	15'-0"			22.927		22'-7 1/2"	Pe -0.000
163	15'-0"			23.621	2LtE(11'-3 3/4")	26'-11"	Pv
FR	6.3570	Q=956.82	9.67	C=120	0.025784	6'-9"	Pf 0.174
163	15'-0"			23.621			Pe 2.926
161	8'-3"			26.721		6'-9"	Pv
MS	6.3570	Q=956.82	9.67	C=120	0.025784	1'-1"	Pf 1.802
161	8'-3"			26.721		68'-9 3/4"	Pe 1.838
84	4'-0 1/4"			30.361	2f(-0.000), CV(40'-2%), BV(12'-7), CV(16'-0)	69'-10 3/4"	Pv
FR	6.0650	Q=956.82	10.63	C=120	0.032419	2'-0"	Pf 0.389
84	4'-0 1/4"			30.361		10'-0"	Pe 1.305
7	1'-0"			32.055	BV(10'-0)	12'-0"	Pv
UG	8.3900	Q=956.82	5.55	C=140	0.005019	135'-2 1/2"	Pf 1.130
7	1'-0"			32.055		89'-11"	Pe 2.601
3	-5'-0"			35.787	E(30'-6 1/2"), T(59'-4 1/2")	225'-1 1/2"	Pv
UG	7.9800	Q=630.97	4.05	C=150	0.002610	303'-2 3/4"	Pf 1.000
3	-5'-0"			35.787		79'-11 3/4"	Pe
5	-5'-0"			36.787	E(27'-2"), T(52'-9 3/4")	383'-2 1/2"	Pv
UG	7.9800	Q=956.82	6.14	C=150	0.005638	1'-11"	Pf 0.121
5	-5'-0"			36.787		19'-7 1/2"	Pe
11	-5'-0"			36.908	LtE(19'-7 1/2")	21'-6 1/2"	Pv
UG	8.3900	Q=956.82	5.55	C=140	0.005019	17'-0"	Pf 12.417
11	-5'-0"			36.908		66'-2"	Pe 0.434
12	-6'-0"			49.759	3LtE(22'-0 3/4"), BFP(-12.000)	83'-2"	Pv
UG	7.9800	Q=956.82	6.14	C=150	0.005638	727'-3"	Pf 4.773
12	-6'-0"			49.759		119'-2 1/2"	Pe
1	-6'-0"			54.532	2E(27'-2"), 2GV(6'-0 1/2"), T(52'-9 3/4"), S	846'-5 3/4"	Pv

Route 2



# Hydraulic Analysis

Job Number: 2441 MAINT  
Report Description: Ordinary Group II

Pipe Type	Diameter	Flow	Velocity	HWC	Friction Loss	Length	Pressure
Downstream	Elevation	Discharge	K-Factor	Pt	Pn	Eq. Length	Summary
Upstream						Total Length	
CM	2.1570	Q=21.17	1.86	C=120	0.004319	11'-0"	Pf 0.048
309	32'-11"	q=21.17	K=8	7.002	Spr(-7.002)		Pe 1.508
310	29'-5 1/4"			8.558		11'-0"	Pv
CM	2.1570	Q=44.57	3.91	C=120	0.017122	11'-0"	Pf 0.188
310	29'-5 1/4"	q=23.40	K=8	8.558	Spr(-8.558)		Pe 1.508
311	25'-11 1/2"			10.254		11'-0"	Pv
CM	2.1570	Q=70.19	6.16	C=120	0.039665	11'-0"	Pf 0.436
311	25'-11 1/2"	q=25.62	K=8	10.254	Spr(-10.254)		Pe 1.508
312	22'-5 1/4"			12.198		11'-0"	Pv
CM	2.1570	Q=98.13	8.62	C=120	0.073729	1'-6"	Pf 0.111
312	22'-5 1/4"	q=27.94	K=8	12.198	Spr(-12.198)		Pe 0.206
147	22'-0"			12.515		1'-6"	Pv
RN	2.1570	Q=98.13	8.62	C=120	0.073729	3'-11 1/2"	Pf 1.471
147	22'-0"			12.515	LtE(3'-8 1/4")	16'-0"	Pe 1.628
129	18'-3"			15.615	PO(12'-3 1/4")	19'-11 1/2"	Pv
***** Route 3 *****							
CM	2.1570	Q=21.18	1.86	C=120	0.004324	11'-0"	Pf 0.048
305	32'-11"	q=21.18	K=8	7.012	Spr(-7.012)		Pe 1.508
306	29'-5 1/4"			8.567		11'-0"	Pv
CM	2.1570	Q=44.60	3.92	C=120	0.017142	11'-0"	Pf 0.189
306	29'-5 1/4"	q=23.42	K=8	8.567	Spr(-8.567)		Pe 1.508
307	25'-11 1/2"			10.264		11'-0"	Pv
CM	2.1570	Q=70.23	6.17	C=120	0.039707	11'-0"	Pf 0.437
307	25'-11 1/2"	q=25.63	K=8	10.264	Spr(-10.264)		Pe 1.508
308	22'-5 1/4"			12.209		11'-0"	Pv
CM	2.1570	Q=98.18	8.62	C=120	0.073802	1'-6"	Pf 0.111
308	22'-5 1/4"	q=27.95	K=8	12.209	Spr(-12.209)		Pe 0.206
149	22'-0"			12.526		1'-6"	Pv
RN	2.1570	Q=98.18	8.62	C=120	0.073802	3'-11 1/2"	Pf 1.473
149	22'-0"			12.526	LtE(3'-8 1/4")	16'-0"	Pe 1.628
131	18'-3"			15.627	PO(12'-3 1/4")	19'-11 1/2"	Pv
CM	4.2600	Q=169.04	3.80	C=120	0.007331	10'-0"	Pf 0.073
131	18'-3"			15.627			Pe
132	18'-3"			15.700		10'-0"	Pv
CM	4.2600	Q=267.54	6.02	C=120	0.017143	171'-11"	Pf 5.024
132	18'-3"			15.700		121'-1 3/4"	Pe 1.409
313	15'-0"			22.133	4T(26'-4"), 2LtE(7'-10 1/2")	293'-0 1/2"	Pv
CM	4.2600	Q=262.59	5.91	C=120	0.016562	13'-4"	Pf 0.221
313	15'-0"			22.133			Pe 0.000
297	15'-0"			22.354		13'-4"	Pv
CM	4.2600	Q=262.38	5.91	C=120	0.016537	19'-6"	Pf 0.322
297	15'-0"			22.354			Pe
198	15'-0"			22.676		19'-6"	Pv
CM	4.2600	Q=267.54	6.02	C=120	0.017143	14'-7 1/2"	Pf 0.251
198	15'-0"			22.676			Pe
284	15'-0"			22.927		14'-7 1/2"	Pv
DY	6.3570	Q=267.54	2.70	C=120	0.002441	0'-0"	Pf 0.000
284	15'-0"			22.927			Pe 0.000
261	15'-0"			22.927		0'-0"	Pv
***** Route 4 *****							
CM	2.1570	Q=21.22	1.86	C=120	0.004338	11'-0"	Pf 0.048
317	32'-11"	q=21.22	K=8	7.036	Spr(-7.036)		Pe 1.508
318	29'-5 1/4"			8.592		11'-0"	Pv
CM	2.1570	Q=44.67	3.92	C=120	0.017192	11'-0"	Pf 0.189
318	29'-5 1/4"	q=23.45	K=8	8.592	Spr(-8.592)		Pe 1.508
319	25'-11 1/2"			10.289		11'-0"	Pv
CM	2.1570	Q=70.33	6.18	C=120	0.039813	11'-0"	Pf 0.438
319	25'-11 1/2"	q=25.66	K=8	10.289	Spr(-10.289)		Pe 1.508
320	22'-5 1/4"			12.235		11'-0"	Pv
CM	2.1570	Q=98.31	8.63	C=120	0.073985	1'-6"	Pf 0.111
320	22'-5 1/4"	q=27.98	K=8	12.235	Spr(-12.235)		Pe 0.206
146	22'-0"			12.552		1'-6"	Pv
RN	2.1570	Q=98.31	8.63	C=120	0.073985	3'-11 1/2"	Pf 1.476
146	22'-0"			12.552	LtE(3'-8 1/4")	16'-0"	Pe 1.628
128	18'-3"			15.657	PO(12'-3 1/4")	19'-11 1/2"	Pv
***** Route 5 *****							
CM	2.1570	Q=21.27	1.87	C=120	0.004358	11'-0"	Pf 0.048
806	32'-11"	q=21.27	K=8	7.071	Spr(-7.071)		Pe 1.508
314	29'-5 1/4"			8.627		11'-0"	Pv
CM	2.1570	Q=44.77	3.93	C=120	0.017264	11'-0"	Pf 0.190
314	29'-5 1/4"	q=23.50	K=8	8.627	Spr(-8.627)		Pe 1.508
315	25'-11 1/2"			10.325		11'-0"	Pv



# Hydraulic Analysis

Job Number: 2441 MAINT  
Report Description: Ordinary Group II

Pipe Type	Diameter	Flow	Velocity	HWC	Friction Loss	Length	Pressure
Downstream	Elevation	Discharge	K-Factor	Pt	Pn	Eq. Length	Summary
Upstream						Total Length	
CM	2.1570	Q=70.48	6.19	C=120		11'-0"	Pf 0.440
315	25'-11½"	q=25.71	K=8	10.325	Spr(-10.325)		Pe 1.508
316	22'-5¾"			12.273		11'-0"	Pv
CM	2.1570	Q=98.50	8.65	C=120		1'-6"	Pf 0.112
316	22'-5¾"	q=28.03	K=8	12.273	Spr(-12.273)		Pe 0.206
150	22'-0"			12.590		1'-6"	Pv
RN	2.1570	Q=98.50	8.65	C=120		3'-11½"	Pf 1.482
150	22'-0"			12.590	LtE(3'-8¾")	16'-0"	Pe 1.628
132	18'-3"			15.700	PO(12'-3¾")	19'-11½"	Pv
<b>Route 6</b>							
CM	2.1570	Q=21.37	1.88	C=120		11'-0"	Pf 0.048
321	32'-11"	q=21.37	K=8	7.136	Spr(-7.136)		Pe 1.508
322	29'-5¼"			8.692		11'-0"	Pv
CM	2.1570	Q=44.96	3.95	C=120		11'-0"	Pf 0.191
322	29'-5¼"	q=23.59	K=8	8.692	Spr(-8.692)		Pe 1.508
323	25'-11½"			10.391		11'-0"	Pv
CM	2.1570	Q=70.74	6.21	C=120		11'-0"	Pf 0.443
323	25'-11½"	q=25.79	K=8	10.391	Spr(-10.391)		Pe 1.508
324	22'-5¾"			12.342		11'-0"	Pv
CM	2.1570	Q=98.85	8.68	C=120		1'-6"	Pf 0.112
324	22'-5¾"	q=28.11	K=8	12.342	Spr(-12.342)		Pe 0.206
145	22'-0"			12.660		1'-6"	Pv
RN	2.1570	Q=98.85	8.68	C=120		3'-11½"	Pf 1.491
145	22'-0"			12.660	LtE(3'-8¾")	16'-0"	Pe 1.628
127	18'-3"			15.780	PO(12'-3¾")	19'-11½"	Pv
<b>Route 7</b>							
CM	2.1570	Q=21.66	1.90	C=120		11'-0"	Pf 0.050
325	32'-11"	q=21.66	K=8	7.331	Spr(-7.331)		Pe 1.508
326	29'-5¼"			8.889		11'-0"	Pv
CM	2.1570	Q=45.51	4.00	C=120		11'-0"	Pf 0.196
326	29'-5¼"	q=23.85	K=8	8.889	Spr(-8.889)		Pe 1.508
327	25'-11½"			10.593		11'-0"	Pv
CM	2.1570	Q=71.55	6.28	C=120		11'-0"	Pf 0.452
327	25'-11½"	q=26.04	K=8	10.593	Spr(-10.593)		Pe 1.508
328	22'-5¾"			12.553		11'-0"	Pv
CM	2.1570	Q=99.89	8.77	C=120		1'-6"	Pf 0.114
328	22'-5¾"	q=28.34	K=8	12.553	Spr(-12.553)		Pe 0.206
144	22'-0"			12.873		1'-6"	Pv
RN	2.1570	Q=99.89	8.77	C=120		3'-11½"	Pf 1.521
144	22'-0"			12.873	LtE(3'-8¾")	16'-0"	Pe 1.628
126	18'-3"			16.022	PO(12'-3¾")	19'-11½"	Pv
<b>Route 8</b>							
CM	2.1570	Q=22.13	1.94	C=120		11'-0"	Pf 0.052
329	32'-11"	q=22.13	K=8	7.654	Spr(-7.654)		Pe 1.508
330	29'-5¼"			9.214		11'-0"	Pv
CM	2.1570	Q=46.42	4.08	C=120		11'-0"	Pf 0.203
330	29'-5¼"	q=24.28	K=8	9.214	Spr(-9.214)		Pe 1.508
331	25'-11½"			10.925		11'-0"	Pv
CM	2.1570	Q=72.86	6.40	C=120		11'-0"	Pf 0.467
331	25'-11½"	q=26.44	K=8	10.925	Spr(-10.925)		Pe 1.508
332	22'-5¾"			12.900		11'-0"	Pv
CM	2.1570	Q=101.59	8.92	C=120		1'-6"	Pf 0.118
332	22'-5¾"	q=28.73	K=8	12.900	Spr(-12.900)		Pe 0.206
143	22'-0"			13.224		1'-6"	Pv
RN	2.1570	Q=101.59	8.92	C=120		3'-11½"	Pf 1.569
143	22'-0"			13.224	LtE(3'-8¾")	16'-0"	Pe 1.628
125	18'-3"			16.421	PO(12'-3¾")	19'-11½"	Pv
<b>Route 9</b>							
CM	2.1570	Q=22.82	2.00	C=120		11'-0"	Pf 0.055
333	32'-11"	q=22.82	K=8	8.135	Spr(-8.135)		Pe 1.508
334	29'-5¼"			9.698		11'-0"	Pv
CM	2.1570	Q=47.73	4.19	C=120		11'-0"	Pf 0.214
334	29'-5¼"	q=24.91	K=8	9.698	Spr(-9.698)		Pe 1.508
335	25'-11½"			11.420		11'-0"	Pv
CM	2.1570	Q=74.77	6.56	C=120		11'-0"	Pf 0.490
335	25'-11½"	q=27.03	K=8	11.420	Spr(-11.420)		Pe 1.508
336	22'-5¾"			13.418		11'-0"	Pv
CM	2.1570	Q=104.07	9.14	C=120		1'-6"	Pf 0.123
336	22'-5¾"	q=29.30	K=8	13.418	Spr(-13.418)		Pe 0.206
142	22'-0"			13.747		1'-6"	Pv
RN	2.1570	Q=104.07	9.14	C=120		3'-11½"	Pf 1.640
142	22'-0"			13.747	LtE(3'-8¾")	16'-0"	Pe 1.628
124	18'-3"			17.016	PO(12'-3¾")	19'-11½"	Pv

# Hydraulic Analysis

Job Number: 2441 MAINT  
Report Description: Ordinary Group II

Pipe Type	Diameter	Flow	Velocity	HWC	Friction Loss	Length	Pressure
Downstream	Elevation	Discharge	K-Factor	Pt	Pn	Eq. Length	Summary
Upstream					Fittings	Total Length	
<b>Route 10</b>							
CM	2.1570	Q=29.75	2.61	C=120	0.008103	11'-0"	Pf 0.089
337	25'-11½"	q=29.75	K=8	13.825	Spr(-13.825)		Pe 1.508
338	22'-5¾"			15.423		11'-0"	Pv
CM	2.1570	Q=61.16	5.37	C=120	0.030748	1'-6"	Pf 0.046
338	22'-5¾"	q=31.42	K=8	15.423	Spr(-15.423)		Pe 0.206
141	22'-0"			15.675		1'-6"	Pv
RN	2.1570	Q=61.16	5.37	C=120	0.030748	3'-11½"	Pf 0.614
141	22'-0"			15.675	LtE(3'-8¾")	16'-0"	Pe 1.628
123	18'-3"			17.917	PO(12'-3¾")	19'-11½"	Pv
<b>Route 11</b>							
CM	2.6350	Q=0.22	0.01	C=120	0.000000	0'-11"	Pf 0.000
482	10'-7¾"			24.241			Pe -0.000
480	10'-7¾"			24.241		0'-11"	Pv
BL	1.0490	Q=0.22	0.08	C=120	0.000030	2'-9¾"	Pf 0.000
480	10'-7¾"			24.241	PO(5'-0)	10'-0"	Pe 1.219
479	7'-10"			25.461	T(5'-0)	12'-9¾"	Pv
BL	1.0490	Q=5.16	1.92	C=120	0.010616	20'-0"	Pf 0.318
479	7'-10"			25.461		10'-0"	Pe -0.217
358	8'-4"			25.563	T(5'-0), PO(5'-0)	30'-0"	Pv
CM	2.6350	Q=5.16	0.30	C=120	0.000120	8'-1¾"	Pf 0.004
358	8'-4"			25.563		21'-11½"	Pe -2.890
198	15'-0"			22.676	LtE(5'-6), PO(16'-5¾")	30'-1¼"	Pv
<b>Route 12</b>							
UG	7.9800	Q=325.85	2.09	C=150	0.000769	1167'-0"	Pf 1.000
3	-5'-0"			35.787		134'-3¾"	Pe
5	-5'-0"			36.787	2E(27'-2), 2EE(13'-7), T(52'-9¾")	1301'-3¾"	Pv
<b>Route 13</b>							
CM	4.2600	Q=70.85	1.59	C=120	0.001468	10'-0"	Pf 0.015
130	18'-3"			15.612			Pe
131	18'-3"			15.627		10'-0"	Pv
<b>Route 14</b>							
BL	1.0490	Q=4.95	1.84	C=120	0.009811	15'-6"	Pf 0.221
530	10'-0"			24.301	PO(5'-0)	7'-0"	Pe 0.939
479	7'-10"			25.461	E(2'-0)	22'-6"	Pv
<b>Route 15</b>							
CM	3.2600	Q=0.22	0.01	C=120	0.000000	4'-4¼"	Pf 0.000
297	15'-0"			22.354	PO(20'-2)	26'-10½"	Pe 1.888
482	10'-7¾"			24.241	LtE(6'-8¾")	31'-2¾"	Pv
<b>Route 16</b>							
CM	4.2600	Q=4.95	0.11	C=120	0.000011	6'-5¾"	Pf 0.000
313	15'-0"			22.133	T(26'-4)	34'-2¾"	Pe 2.168
530	10'-0"			24.301	LtE(7'-10¾")	40'-8½"	Pv

### Equivalent Pipe Lengths of Valves and Fittings (C=120 only)

### C Value Multiplier

$$\left( \frac{\text{Actual Inside Diameter}}{\text{Schedule 40 Steel Pipe Inside Diameter}} \right)^{4.87} = \text{Factor}$$

Value Of C	100	130	140	150
Multiplying Factor	0.713	1.16	1.33	1.51

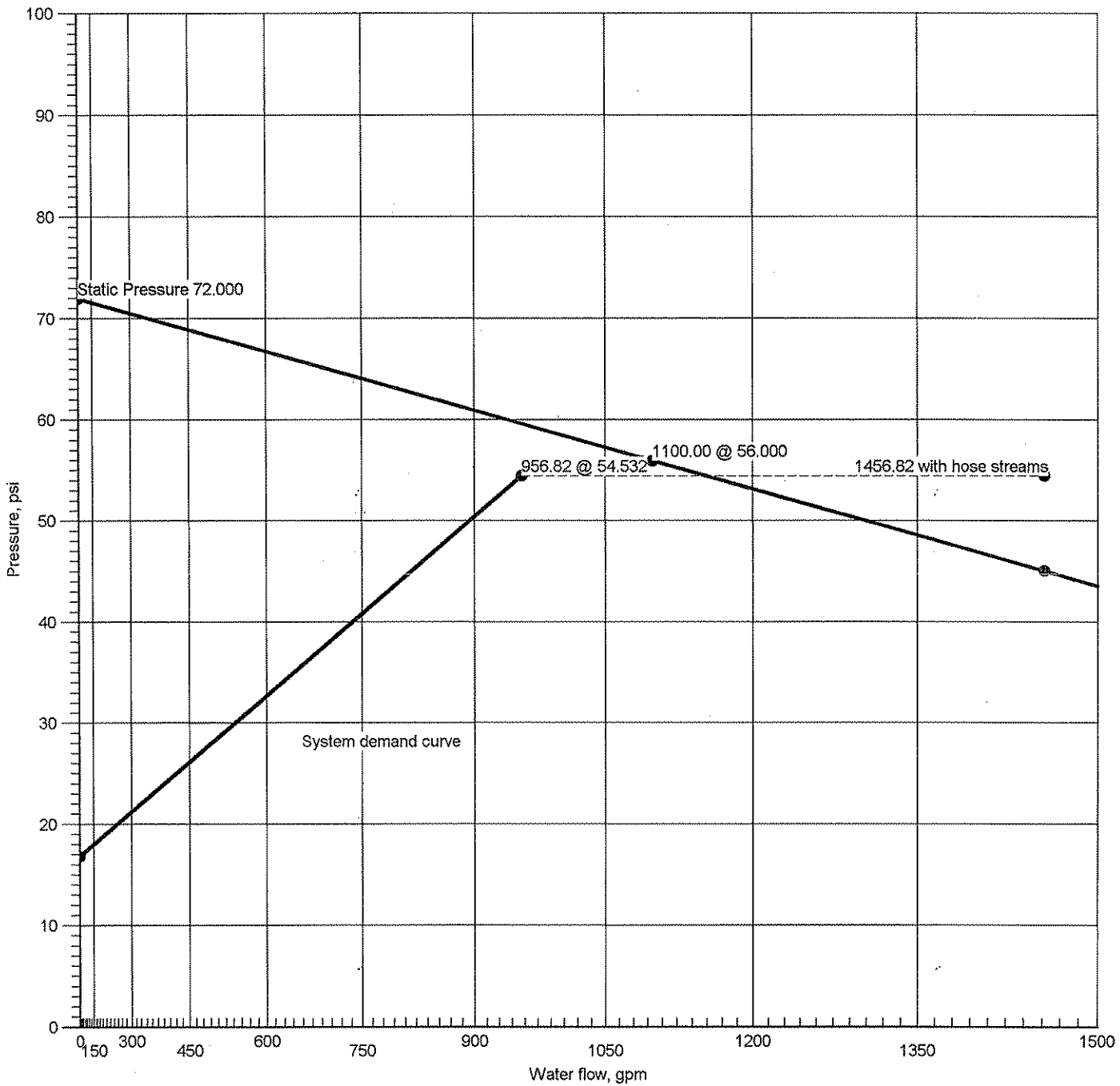
# Hydraulic Analysis

Job Number: 2441 MAINT  
Report Description: Ordinary Group II

Pipe Type	Diameter	Flow	Velocity	HWC	Friction Loss		Length	Pressure
Downstream	Elevation	Discharge	K-Factor	Pt	Pn	Fittings	Eq. Length	Summary
Upstream							Total Length	

Pipe Type Legend		Units Legend		Fittings Legend	
AO	Arm-Over	Diameter	Inch	ALV	Alarm Valve
BL	Branch Line	Elevation	Foot	AngV	Angle Valve
CM	Cross Main	Flow	gpm	b	Bushing
DN	Drain	Discharge	gpm	BalV	Ball Valve
DR	Drop	Velocity	fps	BFP	Backflow Preventer
DY	Dynamic	Pressure	psi	BV	Butterfly Valve
FM	Feed Main	Length	Foot	C	Cross Flow Turn 90°
FR	Feed Riser	Friction Loss	psi/Foot	cplg	Coupling
MS	Miscellaneous	HWC	Hazen-Williams Constant	Cr	Cross Run
OR	Outrigger	Pt	Total pressure at a point in a pipe	CV	Check Valve
RN	Riser Nipple	Pn	Normal pressure at a point in a pipe	DeIV	Deluge Valve
SP	Sprig	Pf	Pressure loss due to friction between points	DPV	Dry Pipe Valve
ST	Stand Pipe	Pe	Pressure due to elevation difference between indicated points	E	90° Elbow
UG	Underground	Pv	Velocity pressure at a point in a pipe	EE	45° Elbow
				Ee1	11¼° Elbow
				Ee2	22½° Elbow
				f	Flow Device
				FDC	Fire Department Connection
				fE	90° FireLock(TM) Elbow
				fEE	45° FireLock(TM) Elbow
				flg	Flange
				FN	Floating Node
				FT	FireLock(TM) Tee
				g	Gauge
				GloV	Globe Valve
				GV	Gate Valve
				Hose	Hose
				HV	Hose Valve
				Hyd	Hydrant
				LtE	Long Turn Elbow
				mecT	Mechanical Tee
				Noz	Nozzle
				P1	Pump In
				P2	Pump Out
				PIV	Post Indicating Valve
				PO	Pipe Outlet
				PrV	Pressure Relief Valve
				PRV	Pressure Reducing Valve
				red	Reducer/Adapter
				S	Supply
				sCV	Swing Check Valve
				Spr	Sprinkler
				St	Strainer
				T	Tee Flow Turn 90°
				Tr	Tee Run
				U	Union
				WirF	Wirsbo
				WMV	Water Meter Valve
				Z	Cap

### Supply at Node 1



Hydraulic Graph
Supply at Node 1
Static Pressure 72.000
Residual Pressure 1100.00 @ 56.000
Available Pressure/Time of Test 45.094 @ 1456.82
System Demand 956.82 @ 54.532
System Demand (Including Hose Allowance) 1456.82 @ 54.532



# Hydraulic Overview

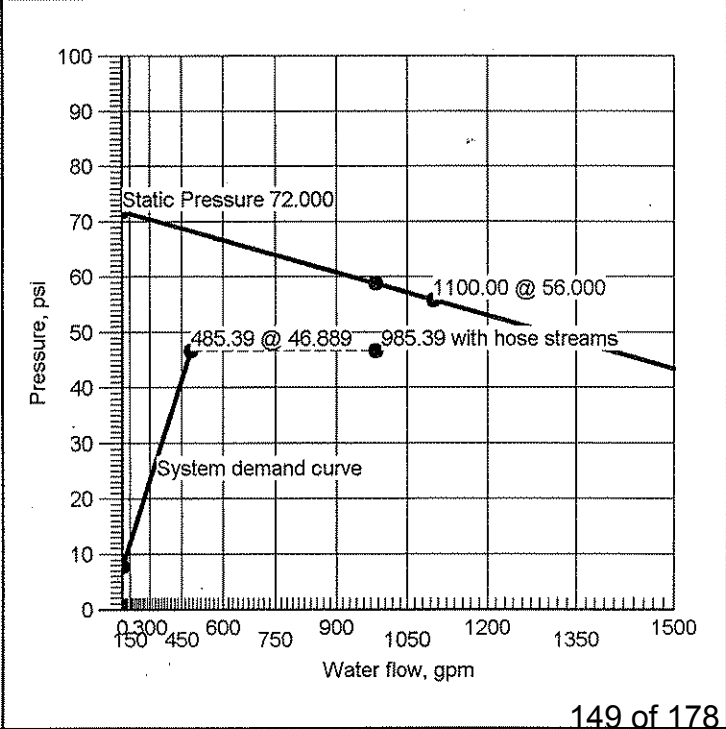
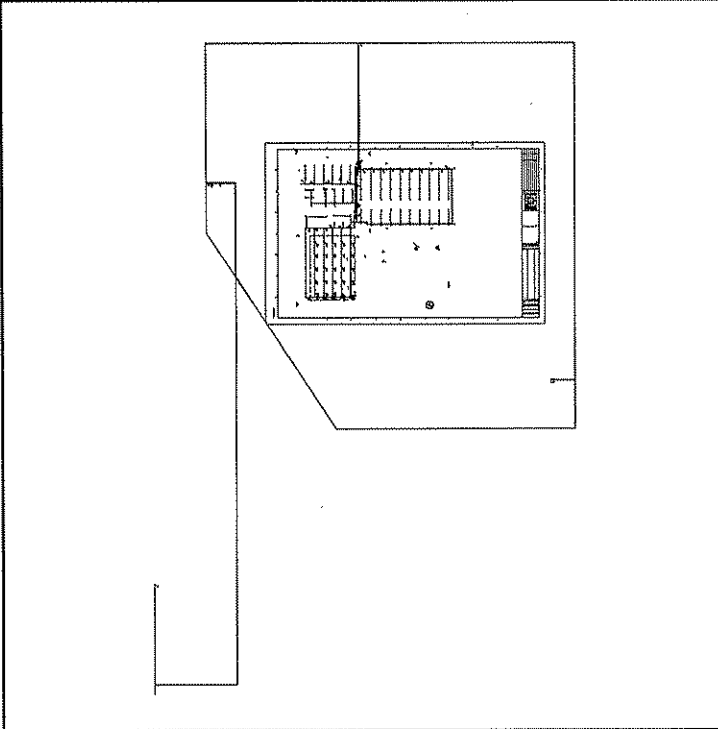
Job Number: 2440 CAGES  
Report Description: Ordinary Group I

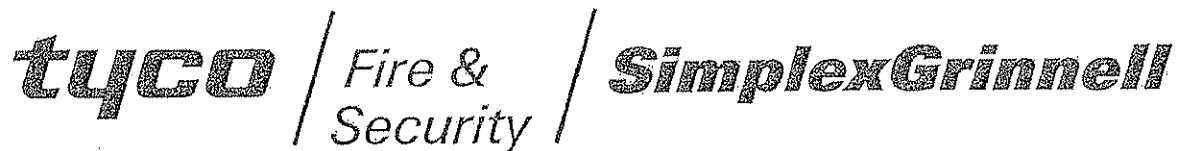
Job Number <b>2440 CAGES</b>			Design Engineer		
Job Name <b>STENNIS RIVERINE BLDG 2440 CAGES</b>			Phone	FAX	
Address 1 <b>OPERATIONS BLDG</b>			State Certification/License Number		
Address 2 <b>STENNIS SPACE CENTER</b>			AHJ		
City <b>STENNIS</b>	State <b>MS</b>	Zip Code	Job Site <b>DEMAND WITH 500 GPM HOSE ALLOWANCE</b>		

<b>System</b>	
Density <b>0.150gpm/ft<sup>2</sup></b>	Area of Application <b>3000.00ft<sup>2</sup> (Actual 3073.29ft<sup>2</sup>)</b>
Most Demanding Sprinkler Data <b>5.6 K-Factor 19.00 at 11.511</b>	Hose Streams <b>500.00</b>
Coverage Per Sprinkler <b>120.00ft<sup>2</sup></b>	Number Of Sprinklers Calculated <b>25</b>
System Pressure Demand <b>46.889</b>	System Flow Demand <b>485.39</b>
Total Demand <b>985.39 @ 46.889</b>	Pressure Result <b>+12.057 (20.5%)</b>

<b>Supplies</b>					<b>Check Point Gauges</b>			
<u>Node</u>	<u>Flow(gpm)</u>	<u>Hose Flow(gpm)</u>	<u>Static(psi)</u>	<u>Residual(psi)</u>	<u>Identifier</u>	<u>Pressure(psi)</u>	<u>K-Factor(K)</u>	<u>Flow(gpm)</u>
1	1100.00	500.00	72.000	56.000				

FP-3 BLDG 2440 2441 1st Floor R5      Supply at Node 1 (1100.00, 500.00, 72.000, 56.000)





STENNIS RIVERINE & COMBATANT TRAINING  
FACILITY  
STENNIS SPACE CENTER  
STENNIS, MS 39529

FIRE PROTECTION/ SPRINKLER SYSTEMS  
OPERATIONS BUILDING 2440/2441  
BOAT STORAGE BUILDING 2442

## SECTION 7

# SEISMIC CALCULATIONS

SIMPLEXGRINNELL  
5800 JEFFERSON HWY SUITE A  
HARAHAN, LA. 70123  
PHONE 504-736-0104  
FAX 504-736-9292



# Tol-Brace Seismic Calculations

For

STENNIS RIVERINE  
STENNIS SPACE CENTER

Job #269-941989101



Brace Identification	LAT1 2440
Brace Type (Per NFPA#13)	NFPA Type D
Spacing of Brace	16 ft.(5m)
Orientation of Brace	Lateral
Bracing Material	1" Sch.40
Length of Brace	7.0167ft. (2m)
Slenderness Ratio used for Load Calculation	200
True Angle of Brace for Calculation	30°
Type of Fastener	N/A In. Fig.825A
Length of Fastener	N/A In.
Length of Fastener	N/A

## Summary of Pipe within Zone of Influence

2½ inch Sch. 10	16 Feet (5m)
2 inch Sch. 10	73 Feet (22m)
Allowance for Heads and Fittings	15%

## Conclusions

Total Adjusted Load of Pipe in Zone of Influence	231 lbs.(105kg.)
Material Capacity	1227 lbs.(557kg.)
Fastener Capacity	632 lbs.(287kg.)
Fig.1000 Clamp	1007 lbs.(457kg.)
Fig.980 Universal Swivel	1382 lbs.(627kg.)
Structural Member:	BAR JOIST*

Calculations prepared by NANCY HINGLE

\*The description of the Structural Member is for informational purposes only.  
Tol-Brace software calculates the brace assembly only, not the structure it is attached to.  
Calculated with Tol-Brace 6.0 Fire  
visit us at [www.tolco.com](http://www.tolco.com)

# Tol-Brace Seismic Calculations



Project Address: STENNIS RIVERINE  
STENNIS SPACE CENTER  
STENNIS, MS  
 Job # 269-941989101

SimplexGrinnell  
 5800 Jefferson Hwy - Suite A  
 Harahan, LA 70123  
 504-613-1083

Calculations based on 2007 NFPA Pamphlet #13

## Brace Information

Maximum Spacing 48'-0" (14.78m)  
 Length of Brace 7'-2" (2.21m)  
 Bracing Material 1" Sch. 10  
 Angle from Vertical 45° Min.  
 Least Rad. of Gyration 0.43" (11mm)  
 L/R Value 200  
 Maximum Horizontal Load 2090 lbs. (948kg.)  
 Force Factor (Fp) 0.5

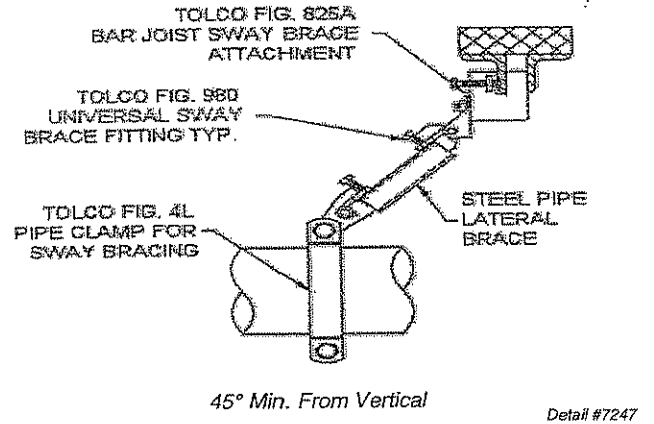
## Fastener Information

Fastener Orientation NFPA Type E  
 Type Fig.825A  
 Diameter N/A  
 Length N/A  
 Maximum Load 894 lbs. (406kg.)

## Tolco Brace Components

**Tolco Component Fig. Number    Adjusted Load**  
 Fig.4L Clamp 1425 lbs. (646 kg.)  
 Fig.980 Universal Swivel 1955 lbs. (887 kg.)  
*\*Calculation Based on CONCENTRIC Loading*  
*\*Please Note: These calculations are for Tolco components only.*  
*Use of any other components voids these calculations and the listing of the assembly.*

### Assembly Detail



Brace Identification on Plans LON1 2440  
 Orientation of Brace Longitudinal

## Load Information

Size and Type of Pipe	Total Length	Total Calculated Load
<i>2½" (63mm) Schedule 10 Pipe</i>	48 ft. (14.6m)	141 lbs. (65kg.)
<i>Percentage added for Fittings and Sprinklers</i>	15 %	21 lbs. (9.62kg.)
<b>Total Adjusted Load of all pipe within Zone of Influence</b>		<b>163 lbs. (74kg.)</b>

(Tol-Brace Version 6.5.1)

# Tol-Brace Seismic Calculations

For

STENNIS RIVERINE  
STENNIS SPACE CENTER

Job #269-941989101



Brace Identification	LON1 2440
Brace Type (Per NFPA#13)	NFPA Type E
Spacing of Brace	48 ft.(15m)
Orientation of Brace	Longitudinal
Bracing Material	1" Sch.10
Length of Brace	7.1667ft. (2m)
Slenderness Ratio used for Load Calculation	200
True Angle of Brace for Calculation	45°
Type of Fastener	N/A In. Fig.825A
Length of Fastener	N/A In.
Length of Fastener	N/A

## Summary of Pipe within Zone of Influence

2½ inch Sch. 10	48 Feet (15m)
Allowance for Heads and Fittings	15%

## Conclusions

Total Adjusted Load of Pipe in Zone of Influence	163 lbs.(74kg.)
Material Capacity	2089.64149661651 lbs.(948kg.)
Fastener Capacity	894 lbs.(406kg.)
Fig.4L Clamp	1425 lbs.(646kg.)
Fig.980 Universal Swivel	1955 lbs.(887kg.)
Structural Member:	BAR JOISTS*

Calculations prepared by NANCY HINGLE

\*The description of the Structural Member is for informational purposes only.  
Tol-Brace software calculates the brace assembly only, not the structure it is attached to.  
Calculated with Tol-Brace 6.0 Fire  
visit us at [www.tolco.com](http://www.tolco.com)

# Tol-Brace Seismic Calculations

Project Address: STENNIS RIVERINE  
STENNIS SPACE CENTER  
STENNIS, MS  
 Job # 269-941989101

SimplexGrinnell  
 5800 Jefferson Hwy - Suite A  
 Harahan, LA 70123  
 504-613-1083



## Brace Information

Maximum Spacing 21'-0" (6.47m)  
 Length of Brace 7'-0" (2.16m)  
 Bracing Material 1" Sch.40  
 Angle from Vertical 60° Min.  
 Least Rad. of Gyration 0.42" (11mm)  
 L/R Value 200  
 Maximum Horizontal Load 2124 lbs. (963kg.)  
 Force Factor (Fp) 0.5

## Fastener Information

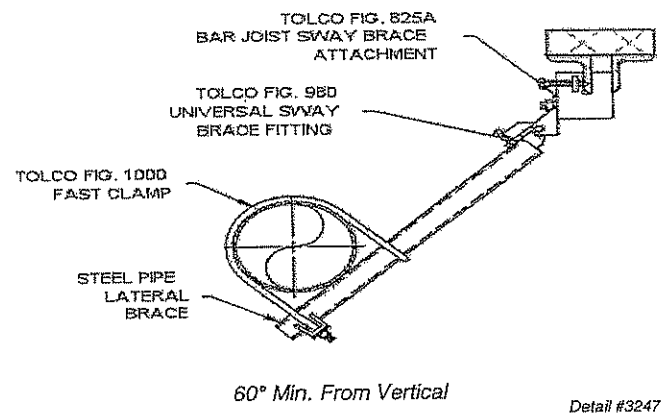
Fastener Orientation NFPA Type F  
 Type Fig.825A  
 Diameter N/A  
 Length N/A  
 Maximum Load 1096 lbs. (497kg.)

## Tolco Brace Components

Tolco Component Fig. Number	Adjusted Load
Fig.1000 Clamp	1745 lbs. (792 kg.)
Fig.980 Universal Swivel	2395 lbs. (1086 kg.)

*\*Calculation Based on CONCENTRIC Loading  
 \*Please Note: These calculations are for Tolco components only.  
 Use of any other components voids these calculations and the listing of the assembly.*

## Assembly Detail



Brace Identification on Plans	LAT2 2440
Orientation of Brace	Lateral

## Load Information

Size and Type of Pipe	Total Length	Total Calculated Load
1"(25mm) Schedule 40 Pipe	45 ft. (13.7m)	46 lbs. (21kg.)
2½"(63mm) Schedule 10 Pipe	21 ft. (6.4m)	62 lbs. (29kg.)
2"(50mm) Schedule 10 Pipe	74 ft. (22.6m)	156 lbs. (71kg.)
Percentage added for Fittings and Sprinklers	15 %	40 lbs.(17.97kg.)
<b>Total Adjusted Load of all pipe within Zone of Influence</b>		<b>304 lbs.(138kg.)</b>

# Tol-Brace Seismic Calculations

For

STENNIS RIVERINE  
STENNIS SPACE CENTER

Job #269-941989101



Brace Identification	LAT2 2440
Brace Type (Per NFPA#13)	NFPA Type F
Spacing of Brace	21 ft.(6m)
Orientation of Brace	Lateral
Bracing Material	1" Sch.40
Length of Brace	7ft. (2m)
Slenderness Ratio used for Load Calculation	200
True Angle of Brace for Calculation	60°
Type of Fastener	N/A In. Fig.825A
Length of Fastener	N/A In.
Length of Fastener	N/A

## Summary of Pipe within Zone of Influence

2½ inch Sch. 10	21 Feet (6m)
2 inch Sch. 10	74 Feet (23m)
1 inch Sch. 40	45 Feet (14m)
Allowance for Heads and Fittings	15%

## Conclusions

Total Adjusted Load of Pipe in Zone of Influence	304 lbs.(138kg.)
Material Capacity	2124 lbs.(963kg.)
Fastener Capacity	1096 lbs.(497kg.)
Fig.1000 Clamp	1745 lbs.(792kg.)
Fig.980 Universal Swivel	2395 lbs.(1086kg.)
Structural Member:	BAR JOIST*

Calculations prepared by NANCY HINGLE

\*The description of the Structural Member is for informational purposes only.  
Tol-Brace software calculates the brace assembly only, not the structure it is attached to.  
Calculated with Tol-Brace 6.0 Fire  
visit us at [www.tolco.com](http://www.tolco.com)

# Tol-Brace Seismic Calculations



Project Address: STENNIS RIVERINE  
STENNIS SPACE CENTER  
STENNIS, MS  
 Job # 269-941989101

SimplexGrinnell  
 5800 Jefferson Hwy - Suite A  
 Harahan, LA 70123  
 504-613-1083

Calculations based on 2007 NFPA Pamphlet #13

Brace Information	Tolco Brace Components
<p>Maximum Spacing <u>50'-0" (15.4m)</u></p> <p>Length of Brace <u>7'-2" (2.21m)</u></p> <p>Bracing Material <u>1" Sch.10</u></p> <p>Angle from Vertical <u>60° Min.</u></p> <p>Least Rad. of Gyration <u>0.43" (11mm)</u></p> <p>L/R Value <u>200</u></p> <p>Maximum Horizontal Load <u>2559 lbs. (1161kg.)</u></p> <p>Force Factor (Fp) <u>0.5</u></p>	<p><b>Tolco Component Fig. Number    Adjusted Load</b></p> <p>Fig.4L Clamp <span style="float: right;">1745 lbs. (792 kg.)</span></p> <p>Fig.980 Universal Swivel <span style="float: right;">2395 lbs. (1086 kg.)</span></p> <p><small>*Calculation Based on CONCENTRIC Loading                      *Please Note: These calculations are for Tolco components only.                      Use of any other components voids these calculations and the listing of the assembly.</small></p>
<b>Fastener Information</b>	<b>Assembly Detail</b>
<p>Fastener Orientation <u>NFPA Type F</u></p> <p>Type <u>Fig.825A</u></p> <p>Diameter <u>N/A</u></p> <p>Length <u>N/A</u></p> <p>Maximum Load <u>1096 lbs. (497kg.)</u></p>	
	<p>Brace Identification on Plans <u>LON2 2440</u></p> <p>Orientation of Brace <u>Longitudinal</u></p>

## Load Information

Size and Type of Pipe	Total Length	Total Calculated Load
<i>2½" (63mm) Schedule 10 Pipe</i>	50 ft. (15.2m)	147 lbs. (67kg.)
<i>Percentage added for Fittings and Sprinklers</i>	15 %	22 lbs.(10.02kg.)
<b>Total Adjusted Load of all pipe within Zone of Influence</b>		<b>169 lbs.(77kg.)</b>

# Tol-Brace Seismic Calculations

For

STENNIS RIVERINE  
STENNIS SPACE CENTER



Job #269-941989101

Brace Identification	LON2 2440
Brace Type (Per NFPA#13)	NFPA Type F
Spacing of Brace	50 ft.(15m)
Orientation of Brace	Longitudinal
Bracing Material	1" Sch.10
Length of Brace	7.1667ft. (2m)
Slenderness Ratio used for Load Calculation	200
True Angle of Brace for Calculation	60°
Type of Fastener	N/A In. Fig.825A
Length of Fastener	N/A In.
Length of Fastener	N/A

## Summary of Pipe within Zone of Influence

2½ inch Sch. 10	50 Feet (15m)
Allowance for Heads and Fittings	15%

## Conclusions

Total Adjusted Load of Pipe in Zone of Influence	169 lbs.(77kg.)
Material Capacity	2559.2780968651 lbs.(1161kg.)
Fastener Capacity	1096 lbs.(497kg.)
Fig.4L Clamp	1745 lbs.(792kg.)
Fig.980 Universal Swivel	2395 lbs.(1086kg.)
Structural Member:	BAR JOIST*

Calculations prepared by NANCY HINGLE

\*The description of the Structural Member is for informational purposes only.  
Tol-Brace software calculates the brace assembly only, not the structure it is attached to.  
Calculated with Tol-Brace 6.0 Fire  
visit us at [www.tolco.com](http://www.tolco.com)

# Tol-Brace Seismic Calculations

Project Address: STENNIS RIVERINE  
STENNIS SPACE CENTER  
STENNIS, MS  
 Job # 269-941989101

SimplexGrinnell  
 5800 Jefferson Hwy - Suite A  
 Harahan, LA 70123  
 504-613-1083



Calculations based on 2007 NFPA Pamphlet #13

Brace Information	
Maximum Spacing	<u>28'-0" (8.62m)</u>
Length of Brace	<u>7'-0" (2.16m)</u>
Bracing Material	<u>1" Sch.40</u>
Angle from Vertical	<u>45° Min.</u>
Least Rad. of Gyration	<u>0.42" (11mm)</u>
L/R Value	<u>200</u>
Maximum Horizontal Load	<u>1735 lbs. (787kg.)</u>
Force Factor (Fp)	<u>0.5</u>

Tolco Brace Components	
Tolco Component Fig. Number	Adjusted Load
Fig.1000 Clamp	1425 lbs. (646 kg.)
Fig.980 Universal Swivel	1955 lbs. (887 kg.)
*Calculation Based on CONCENTRIC Loading	
*Please Note: These calculations are for Tolco components only. Use of any other components voids these calculations and the listing of the assembly.	

Fastener Information	
Fastener Orientation	<u>NFPA Type B</u>
Type	<u>Fig.800 Across Beam</u>
Diameter	<u>N/A</u>
Length	<u>N/A</u>
Maximum Load	<u>1425 lbs. (646kg.)</u>

### Assembly Detail

Detail #3244

Brace Identification on Plans	<u>LAT3 2440</u>
Orientation of Brace	<u>Lateral</u>

## Load Information

Size and Type of Pipe	Total Length	Total Calculated Load
<u>2½"(63mm) Schedule 10 Pipe</u>	<u>28 ft. (8.5m)</u>	<u>82 lbs. (38kg.)</u>
<u>2"(50mm) Schedule 10 Pipe</u>	<u>65 ft. (19.8m)</u>	<u>137 lbs. (63kg.)</u>
<u>Percentage added for Fittings and Sprinklers</u>	<u>15 %</u>	<u>33 lbs.(14.94kg.)</u>
<b>Total Adjusted Load of all pipe within Zone of Influence</b>		<u>253 lbs.(115kg.)</u>

(Tol-Brace Version 6.5.1)

# Tol-Brace Seismic Calculations

For

STENNIS RIVERINE  
STENNIS SPACE CENTER

Job #269-941989101



Brace Identification	LAT3 2440
Brace Type (Per NFPA#13)	NFPA Type B
Spacing of Brace	28 ft.(9m)
Orientation of Brace	Lateral
Bracing Material	1" Sch.40
Length of Brace	7ft. (2m)
Slenderness Ratio used for Load Calculation	200
True Angle of Brace for Calculation	45°
Type of Fastener	N/A In. Fig.800 Across Beam
Length of Fastener	N/A In.
Length of Fastener	N/A

## Summary of Pipe within Zone of Influence

2½ inch Sch. 10	28 Feet (9m)
2 inch Sch. 10	65 Feet (20m)
Allowance for Heads and Fittings	15%

## Conclusions

Total Adjusted Load of Pipe in Zone of Influence	253 lbs.(115kg.)
Material Capacity	1735 lbs.(787kg.)
Fastener Capacity	1425 lbs.(646kg.)
Fig.1000 Clamp	1425 lbs.(646kg.)
Fig.980 Universal Swivel	1955 lbs.(887kg.)
Structural Member:	I-BEAM*

Calculations prepared by NANCY HINGLE

\*The description of the Structural Member is for informational purposes only.  
Tol-Brace software calculates the brace assembly only, not the structure it is attached to.  
Calculated with Tol-Brace 6.0 Fire  
visit us at [www.tolco.com](http://www.tolco.com)

# Tol-Brace Seismic Calculations



Project Address: STENNIS RIVERINE  
STENNIS SPACE CENTER  
STENNIS, MS  
 Job # 269-941989101

SimplexGrinnell  
 5800 Jefferson Hwy - Suite A  
 Harahan, LA 70123  
 504-613-1083

Calculations based on 2007 NFPA Pamphlet #13

Brace Information	Tolco Brace Components
Maximum Spacing <u>55'-0" (16.94m)</u>	<b>Tolco Component Fig. Number    Adjusted Load</b>
Length of Brace <u>7'-2" (2.21m)</u>	Fig.4L Clamp <span style="float: right;">1425 lbs. (646 kg.)</span>
Bracing Material <u>1" Sch.10</u>	Fig.980 Universal Swivel <span style="float: right;">1955 lbs. (887 kg.)</span>
Angle from Vertical <u>45° Min.</u>	<i>*Calculation Based on CONCENTRIC Loading</i>
Least Rad. of Gyration <u>0.43" (11mm)</u>	<i>*Please Note: These calculations are for Tolco components only.</i>
L/R Value <u>200</u>	<i>Use of any other components voids these calculations and the listing of the assembly.</i>
Maximum Horizontal Load <u>2090 lbs. (948kg.)</u>	<h3 style="margin: 0;">Assembly Detail</h3>
Force Factor (Fp) <u>0.5</u>	
Fastener Information	
Fastener Orientation <u>NFPA Type B</u>	
Type <u>Fig.800 Across Beam</u>	
Diameter <u>N/A</u>	
Length <u>N/A</u>	
Maximum Load <u>1425 lbs. (646kg.)</u>	
	Brace Identification on Plans <span style="float: right;">LON3 2440</span>
	Orientation of Brace <span style="float: right;">Longitudinal</span>

## Load Information

Size and Type of Pipe	Total Length	Total Calculated Load
<i>2½" (63mm) Schedule 10 Pipe</i>	55 ft. (16.8m)	162 lbs. (74kg.)
<i>Percentage added for Fittings and Sprinklers</i>	15 %	24 lbs. (11.02kg.)
<b>Total Adjusted Load of all pipe within Zone of Influence</b>		<b>186 lbs. (85kg.)</b>

# Tol-Brace Seismic Calculations

For

STENNIS RIVERINE  
STENNIS SPACE CENTER

Job #269-941989101



Brace Identification	LON3 2440
Brace Type (Per NFPA#13)	NFPA Type B
Spacing of Brace	55 ft.(17m)
Orientation of Brace	Longitudinal
Bracing Material	1" Sch.10
Length of Brace	7.1667ft. (2m)
Slenderness Ratio used for Load Calculation	200
True Angle of Brace for Calculation	45°
Type of Fastener	N/A In. Fig.800 Across Beam
Length of Fastener	N/A In.
Length of Fastener	N/A

## Summary of Pipe within Zone of Influence

2½ inch Sch. 10	55 Feet (17m)
Allowance for Heads and Fittings	15%

## Conclusions

Total Adjusted Load of Pipe in Zone of Influence	186 lbs.(84kg.)
Material Capacity	2089.64149661651 lbs.(948kg.)
Fastener Capacity	1425 lbs.(646kg.)
Fig.4L Clamp	1425 lbs.(646kg.)
Fig.980 Universal Swivel	1955 lbs.(887kg.)
Structural Member:	I-BEAM*

Calculations prepared by NANCY HINGLE

\*The description of the Structural Member is for informational purposes only.  
Tol-Brace software calculates the brace assembly only, not the structure it is attached to.  
Calculated with Tol-Brace 6.0 Fire  
visit us at [www.tolco.com](http://www.tolco.com)

# Tol-Brace Seismic Calculations

Project Address: STENNIS RIVERINE  
STENNIS SPACE CENTER  
STENNIS, MS  
 Job # 269-941989101

SimplexGrinnell  
 5800 Jefferson Hwy - Suite A  
 Harahan, LA 70123  
 504-613-1083



Brace Information	
Maximum Spacing	<u>22'-0" (6.78m)</u>
Length of Brace	<u>7'-0" (2.16m)</u>
Bracing Material	<u>1" Sch.40</u>
Angle from Vertical	<u>60° Min.</u>
Least Rad. of Gyration	<u>0.42" (11mm)</u>
L/R Value	<u>200</u>
Maximum Horizontal Load	<u>2124 lbs. (963kg.)</u>
Force Factor (Fp)	<u>0.5</u>

Tolco Brace Components	
Tolco Component Fig. Number	Adjusted Load
Fig.1000 Clamp	1745 lbs. (792 kg.)
Fig.980 Universal Swivel	2395 lbs. (1086 kg.)
*Calculation Based on CONCENTRIC Loading *Please Note: These calculations are for Tolco components only. Use of any other components voids these calculations and the listing of the assembly.	

Fastener Information	
Fastener Orientation	<u>NFPA Type C</u>
Type	<u>Fig.800 Across Beam</u>
Diameter	<u>N/A</u>
Length	<u>N/A</u>
Maximum Load	<u>1745 lbs. (792kg.)</u>

### Assembly Detail

60° Min. From Vertical  
Detail #3244

Brace Identification on Plans	<u>LAT4 2440 2ND FL</u>
Orientation of Brace	<u>Lateral</u>

## Load Information

Size and Type of Pipe	Total Length	Total Calculated Load
<u>1"(25mm) Schedule 40 Pipe</u>	<u>25 ft. (7.6m)</u>	<u>26 lbs. (12kg.)</u>
<u>3"(75mm) Schedule 10 Pipe</u>	<u>22 ft. (6.7m)</u>	<u>87 lbs. (40kg.)</u>
<u>2"(50mm) Schedule 10 Pipe</u>	<u>47 ft. (14.3m)</u>	<u>99 lbs. (45kg.)</u>
<u>Percentage added for Fittings and Sprinklers</u>	<u>15 %</u>	<u>32 lbs.(14.43kg.)</u>
<b>Total Adjusted Load of all pipe within Zone of Influence</b>		<u>244 lbs.(111kg.)</u>

# Tol-Brace Seismic Calculations

For

STENNIS RIVERINE  
STENNIS SPACE CENTER

Job #269-941989101



Brace Identification	LAT4 2440 2ND FL
Brace Type (Per NFPA#13)	NFPA Type C
Spacing of Brace	22 ft.(7m)
Orientation of Brace	Lateral
Bracing Material	1" Sch.40
Length of Brace	7ft. (2m)
Slenderness Ratio used for Load Calculation	200
True Angle of Brace for Calculation	60°
Type of Fastener	N/A In. Fig.800 Across Beam
Length of Fastener	N/A In.
Length of Fastener	N/A

## Summary of Pipe within Zone of Influence

3 inch Sch. 10	22 Feet (7m)
2 inch Sch. 10	47 Feet (14m)
1 inch Sch. 40	25 Feet (8m)
Allowance for Heads and Fittings	15%

## Conclusions

Total Adjusted Load of Pipe in Zone of Influence	244 lbs.(111kg.)
Material Capacity	2124 lbs.(963kg.)
Fastener Capacity	1745 lbs.(792kg.)
Fig.1000 Clamp	1745 lbs.(792kg.)
Fig.980 Universal Swivel	2395 lbs.(1086kg.)
Structural Member:	RIGID FRAME*

Calculations prepared by NANCY HINGLE

\*The description of the Structural Member is for informational purposes only.  
Tol-Brace software calculates the brace assembly only, not the structure it is attached to.  
Calculated with Tol-Brace 6.0 Fire  
visit us at [www.tolco.com](http://www.tolco.com)

# Tol-Brace Seismic Calculations

Project Address: STENNIS RIVERINE  
STENNIS SPACE CENTER  
STENNIS, MS  
 Job # 269-941989101

SimplexGrinnell  
 5800 Jefferson Hwy - Suite A  
 Harahan, LA 70123  
 504-613-1083



Calculations based on 2007 NFPA Pamphlet #13

Brace Information	Tolco Brace Components						
Maximum Spacing <u>48'-0" (14.78m)</u> Length of Brace <u>7'-2" (2.21m)</u> Bracing Material <u>1" Sch.10</u> Angle from Vertical <u>60° Min.</u> Least Rad. of Gyration <u>0.43" (11mm)</u> L/R Value <u>200</u> Maximum Horizontal Load <u>2559 lbs. (1161kg.)</u> Force Factor (Fp) <u>0.5</u>	<table style="width: 100%;"> <tr> <th style="text-align: left;">Tolco Component Fig. Number</th> <th style="text-align: left;">Adjusted Load</th> </tr> <tr> <td>Fig.4L Clamp</td> <td>1745 lbs. (792 kg.)</td> </tr> <tr> <td>Fig.980 Universal Swivel</td> <td>2395 lbs. (1086 kg.)</td> </tr> </table> <p><i>*Calculation Based on CONCENTRIC Loading                      *Please Note: These calculations are for Tolco components only.                      Use of any other components voids these calculations and the listing of the assembly.</i></p>	Tolco Component Fig. Number	Adjusted Load	Fig.4L Clamp	1745 lbs. (792 kg.)	Fig.980 Universal Swivel	2395 lbs. (1086 kg.)
Tolco Component Fig. Number	Adjusted Load						
Fig.4L Clamp	1745 lbs. (792 kg.)						
Fig.980 Universal Swivel	2395 lbs. (1086 kg.)						
<h3 style="text-align: center;">Fastener Information</h3> Fastener Orientation <u>NFPA Type C</u> Type <u>Fig.800 Across Beam</u> Diameter <u>N/A</u> Length <u>N/A</u> Maximum Load <u>1745 lbs. (792kg.)</u>	<h3 style="text-align: center;">Assembly Detail</h3> <p style="text-align: center;">60° Min. From Vertical <span style="float: right;">Detail #7244</span></p> <table style="width: 100%;"> <tr> <td>Brace Identification on Plans</td> <td>LON4 2440 2ND FL</td> </tr> <tr> <td>Orientation of Brace</td> <td>Longitudinal</td> </tr> </table>	Brace Identification on Plans	LON4 2440 2ND FL	Orientation of Brace	Longitudinal		
Brace Identification on Plans	LON4 2440 2ND FL						
Orientation of Brace	Longitudinal						

## Load Information

Size and Type of Pipe	Total Length	Total Calculated Load
3"(75mm) Schedule 10 Pipe	48 ft. (14.6m)	191 lbs. (87kg.)
Percentage added for Fittings and Sprinklers	15 %	29 lbs.(12.97kg.)
<b>Total Adjusted Load of all pipe within Zone of Influence</b>		<b>219 lbs.(100kg.)</b>

(Tol-Brace Version 6.5.1)

# Tol-Brace Seismic Calculations

For

STENNIS RIVERINE  
STENNIS SPACE CENTER

Job #269-941989101



Brace Identification	LON4 2440 2ND FL
Brace Type (Per NFPA#13)	NFPA Type C
Spacing of Brace	48 ft.(15m)
Orientation of Brace	Longitudinal
Bracing Material	1" Sch.10
Length of Brace	7.1667ft. (2m)
Slenderness Ratio used for Load Calculation	200
True Angle of Brace for Calculation	60°
Type of Fastener	N/A In. Fig.800 Across Beam
Length of Fastener	N/A In.
Length of Fastener	N/A

## Summary of Pipe within Zone of Influence

3 inch Sch. 10	48 Feet (15m)
Allowance for Heads and Fittings	15%

## Conclusions

Total Adjusted Load of Pipe in Zone of Influence	219 lbs.(99kg.)
Material Capacity	2559.2780968651 lbs.(1161kg.)
Fastener Capacity	1745 lbs.(792kg.)
Fig.4L Clamp	1745 lbs.(792kg.)
Fig.980 Universal Swivel	2395 lbs.(1086kg.)
Structural Member:	RIGID FRAME*

Calculations prepared by NANCY HINGLE

\*The description of the Structural Member is for informational purposes only.  
Tol-Brace software calculates the brace assembly only, not the structure it is attached to.  
Calculated with Tol-Brace 6.0 Fire  
visit us at [www.tolco.com](http://www.tolco.com)

# Tol-Brace Seismic Calculations

Project Address: STENNIS RIVERINE  
STENNIS SPACE CENTER  
STENNIS, MS  
 Job # 269-941989101

SimplexGrinnell  
 5800 Jefferson Hwy - Suite A  
 Harahan, LA 70123  
 504-613-1083



Brace Information	
Maximum Spacing	<u>30'-0" (9.24m)</u>
Length of Brace	<u>7'-0" (2.16m)</u>
Bracing Material	<u>1" Sch.40</u>
Angle from Vertical	<u>60° Min.</u>
Least Rad. of Gyration	<u>0.42" (11mm)</u>
L/R Value	<u>200</u>
Maximum Horizontal Load	<u>2124 lbs. (963kg.)</u>
Force Factor (Fp)	<u>0.5</u>

Tolco Brace Components	
Tolco Component Fig. Number	Adjusted Load
Fig.1000 Clamp	1745 lbs. (792 kg.)
Fig.980 Universal Swivel	2395 lbs. (1086 kg.)
*Calculation Based on CONCENTRIC Loading *Please Note: These calculations are for Tolco components only. Use of any other components voids these calculations and the listing of the assembly.	

Fastener Information	
Fastener Orientation	<u>NFPA Type C</u>
Type	<u>Fig.800 Across Beam</u>
Diameter	<u>N/A</u>
Length	<u>N/A</u>
Maximum Load	<u>1745 lbs. (792kg.)</u>

### Assembly Detail

Detail #3244

Brace Identification on Plans	<u>LAT5 2441</u>
Orientation of Brace	<u>Lateral</u>

## Load Information

Size and Type of Pipe	Total Length	Total Calculated Load
4"(100mm) Schedule 10 Pipe	30 ft. (9.1m)	177 lbs. (81kg.)
2"(50mm) Schedule 10 Pipe	117 ft. (35.7m)	247 lbs. (112kg.)
Percentage added for Fittings and Sprinklers	15 %	64 lbs.(28.82kg.)
<b>Total Adjusted Load of all pipe within Zone of Influence</b>		<b>487 lbs.(221kg.)</b>

(Tol-Brace Version 6.5.1)

# Tol-Brace Seismic Calculations

For

STENNIS RIVERINE  
STENNIS SPACE CENTER

Job #269-941989101



Brace Identification	LAT5 2441
Brace Type (Per NFPA#13)	NFPA Type C
Spacing of Brace	30 ft.(9m)
Orientation of Brace	Lateral
Bracing Material	1" Sch.40
Length of Brace	7ft. (2m)
Slenderness Ratio used for Load Calculation	200
True Angle of Brace for Calculation	60°
Type of Fastener	N/A In. Fig.800 Across Beam
Length of Fastener	N/A In.
Length of Fastener	N/A

## Summary of Pipe within Zone of Influence

4 inch Sch. 10	30 Feet (9m)
2 inch Sch. 10	117 Feet (36m)
Allowance for Heads and Fittings	15%

## Conclusions

Total Adjusted Load of Pipe in Zone of Influence	487 lbs.(221kg.)
Material Capacity	2124 lbs.(963kg.)
Fastener Capacity	1745 lbs.(792kg.)
Fig.1000 Clamp	1745 lbs.(792kg.)
Fig.980 Universal Swivel	2395 lbs.(1086kg.)
Structural Member:	RIGID FRAME*

Calculations prepared by NANCY HINGLE

\*The description of the Structural Member is for informational purposes only.  
Tol-Brace software calculates the brace assembly only, not the structure it is attached to.  
Calculated with Tol-Brace 6.0 Fire  
visit us at [www.tolco.com](http://www.tolco.com)

# Tol-Brace Seismic Calculations

Project Address: STENNIS RIVERINE  
STENNIS SPACE CENTER  
STENNIS, MS  
 Job # 269-941989101

SimplexGrinnell  
 5800 Jefferson Hwy - Suite A  
 Harahan, LA 70123  
 504-613-1083



Calculations based on 2007 NFPA Pamphlet #13

Brace Information	Tolco Brace Components								
Maximum Spacing <u>50'-0" (15.4m)</u> Length of Brace <u>7'-2" (2.21m)</u> Bracing Material <u>1" Sch.10</u> Angle from Vertical <u>60° Min.</u> Least Rad. of Gyration <u>0.43" (11mm)</u> L/R Value <u>200</u> Maximum Horizontal Load <u>2559 lbs. (1161kg.)</u> Force Factor (Fp) <u>0.5</u>	<table style="width: 100%; border-collapse: collapse;"> <tr> <th style="text-align: left;">Tolco Component Fig. Number</th> <th style="text-align: left;">Adjusted Load</th> </tr> <tr> <td>Fig.4L Clamp</td> <td>1745 lbs. (792 kg.)</td> </tr> <tr> <td>Fig.980 Universal Swivel</td> <td>2395 lbs. (1086 kg.)</td> </tr> <tr> <td colspan="2">*Calculation Based on CONCENTRIC Loading                      *Please Note: These calculations are for Tolco components only.                      Use of any other components voids these calculations and the listing of the assembly.</td> </tr> </table>	Tolco Component Fig. Number	Adjusted Load	Fig.4L Clamp	1745 lbs. (792 kg.)	Fig.980 Universal Swivel	2395 lbs. (1086 kg.)	*Calculation Based on CONCENTRIC Loading *Please Note: These calculations are for Tolco components only. Use of any other components voids these calculations and the listing of the assembly.	
Tolco Component Fig. Number	Adjusted Load								
Fig.4L Clamp	1745 lbs. (792 kg.)								
Fig.980 Universal Swivel	2395 lbs. (1086 kg.)								
*Calculation Based on CONCENTRIC Loading *Please Note: These calculations are for Tolco components only. Use of any other components voids these calculations and the listing of the assembly.									
<b>Fastener Information</b>	<b>Assembly Detail</b>								
Fastener Orientation <u>NFPA Type C</u> Type <u>Fig.800 Across Beam</u> Diameter <u>N/A</u> Length <u>N/A</u> Maximum Load <u>1745 lbs. (792kg.)</u>									
	<table style="width: 100%; border-collapse: collapse;"> <tr> <td style="width: 60%;">Brace Identification on Plans</td> <td>LON5 2441</td> </tr> <tr> <td>Orientation of Brace</td> <td>Longitudinal</td> </tr> </table>	Brace Identification on Plans	LON5 2441	Orientation of Brace	Longitudinal				
Brace Identification on Plans	LON5 2441								
Orientation of Brace	Longitudinal								

## Load Information

Size and Type of Pipe	Total Length	Total Calculated Load
4"(100mm) Schedule 10 Pipe	50 ft. (15.2m)	294 lbs. (134kg.)
Percentage added for Fittings and Sprinklers	15 %	44 lbs.(20.04kg.)
<b>Total Adjusted Load of all pipe within Zone of Influence</b>		<b>339 lbs.(154kg.)</b>

(Tol-Brace Version 6.5.1)

# Tol-Brace Seismic Calculations

For

STENNIS RIVERINE  
STENNIS SPACE CENTER

Job #269-941989101



Brace Identification	LON5 2441
Brace Type (Per NFPA#13)	NFPA Type C
Spacing of Brace	50 ft.(15m)
Orientation of Brace	Longitudinal
Bracing Material	1" Sch.10
Length of Brace	7.1667ft. (2m)
Slenderness Ratio used for Load Calculation	200
True Angle of Brace for Calculation	60°
Type of Fastener	N/A In. Fig.800 Across Beam
Length of Fastener	N/A In.
Length of Fastener	N/A

## Summary of Pipe within Zone of Influence

4 inch Sch. 10	50 Feet (15m)
Allowance for Heads and Fittings	15%

## Conclusions

Total Adjusted Load of Pipe in Zone of Influence	339 lbs.(154kg.)
Material Capacity	2559.2780968651 lbs.(1161 kg.)
Fastener Capacity	1745 lbs.(792kg.)
Fig.4L Clamp	1745 lbs.(792kg.)
Fig.980 Universal Swivel	2395 lbs.(1086kg.)
Structural Member:	RIGID FRAME*

Calculations prepared by NANCY HINGLE

\*The description of the Structural Member is for informational purposes only.  
Tol-Brace software calculates the brace assembly only, not the structure it is attached to.  
Calculated with Tol-Brace 6.0 Fire  
visit us at [www.tolco.com](http://www.tolco.com)

# Tol-Brace Seismic Calculations

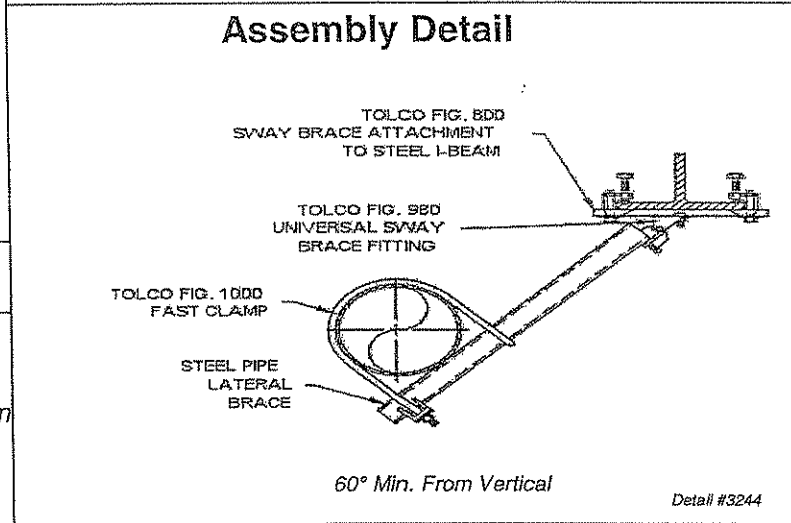
Project Address: STENNIS RIVERINE  
STENNIS SPACE CENTER  
STENNIS, MS  
 Job # 269-941989101

SimplexGrinnell  
 5800 Jefferson Hwy - Suite A  
 Harahan, LA 70123  
 504-613-1083



Brace Information	
Maximum Spacing	<u>30'-0" (9.24m)</u>
Length of Brace	<u>7'-0" (2.16m)</u>
Bracing Material	<u>1" Sch.40</u>
Angle from Vertical	<u>60° Min.</u>
Least Rad. of Gyration	<u>0.42" (11mm)</u>
L/R Value	<u>200</u>
Maximum Horizontal Load	<u>2124 lbs. (963kg.)</u>
Force Factor (Fp)	<u>0.5</u>

Tolco Brace Components	
<b>Tolco Component Fig. Number</b>	<b>Adjusted Load</b>
Fig.1000 Clamp	1096 lbs. (497 kg.)
Fig.980 Universal Swivel	2395 lbs. (1086 kg.)
*Calculation Based on CONCENTRIC Loading *Please Note: These calculations are for Tolco components only. Use of any other components voids these calculations and the listing of the assembly.	



Fastener Information	
Fastener Orientation	<u>NFPA Type C</u>
Type	<u>Fig.800 Across Beam</u>
Diameter	<u>N/A</u>
Length	<u>N/A</u>
Maximum Load	<u>1745 lbs. (792kg.)</u>

Brace Identification on Plans	<u>LAT6 2442</u>
Orientation of Brace	<u>Lateral</u>

## Load Information

Size and Type of Pipe	Total Length	Total Calculated Load
6"(150mm) Schedule 10 Pipe	30 ft. (9.1m)	345 lbs. (157kg.)
2"(50mm) Schedule 10 Pipe	72 ft. (21.9m)	152 lbs. (69kg.)
Percentage added for Fittings and Sprinklers	15 %	75 lbs.(33.84kg.)
<b>Total Adjusted Load of all pipe within Zone of Influence</b>		<b>572 lbs.(260kg.)</b>

(Tol-Brace Version 6.5.1)

# Tol-Brace Seismic Calculations

For

STENNIS RIVERINE  
STENNIS SPACE CENTER

Job #269-941989101



Brace Identification	LAT6 2442
Brace Type (Per NFPA#13)	NFPA Type C
Spacing of Brace	30 ft.(9m)
Orientation of Brace	Lateral
Bracing Material	1" Sch.40
Length of Brace	7ft. (2m)
Slenderness Ratio used for Load Calculation	200
True Angle of Brace for Calculation	60°
Type of Fastener	N/A In. Fig.800 Across Beam
Length of Fastener	N/A In.
Length of Fastener	N/A

## Summary of Pipe within Zone of Influence

6 inch Sch. 10	30 Feet (9m)
2 inch Sch. 10	72 Feet (22m)
Allowance for Heads and Fittings	15%

## Conclusions

Total Adjusted Load of Pipe in Zone of Influence	572 lbs.(259kg.)
Material Capacity	2124 lbs.(963kg.)
Fastener Capacity	1745 lbs.(792kg.)
Fig.1000 Clamp	1096 lbs.(497kg.)
Fig.980 Universal Swivel	2395 lbs.(1086kg.)
Structural Member:	RIGID FRAME*

Calculations prepared by NANCY HINGLE

\*The description of the Structural Member is for informational purposes only.  
Tol-Brace software calculates the brace assembly only, not the structure it is attached to.  
Calculated with Tol-Brace 6.0 Fire  
visit us at [www.tolco.com](http://www.tolco.com)

# Tol-Brace Seismic Calculations

Project Address: STENNIS RIVERINE  
STENNIS SPACE CENTER  
STENNIS, MS  
 Job # 269-941989101

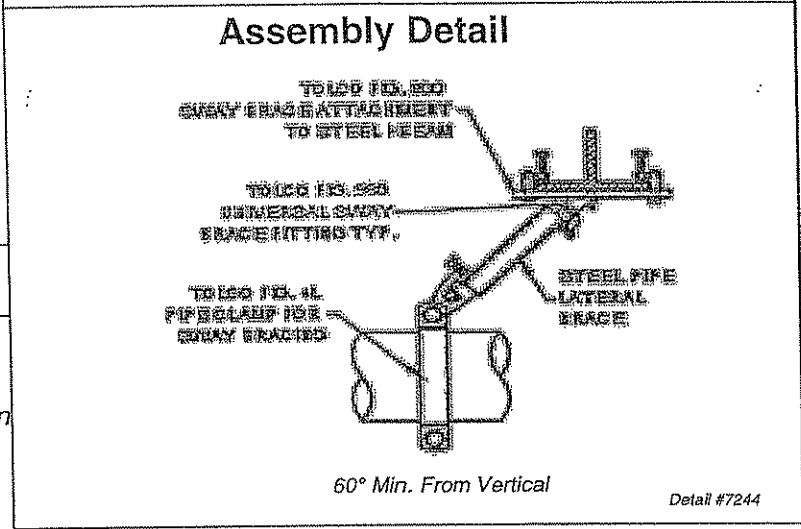
SimplexGrinnell  
 5800 Jefferson Hwy - Suite A  
 Harahan, LA 70123  
 504-613-1083



Brace Information	
Maximum Spacing	<u>30'-0" (9.24m)</u>
Length of Brace	<u>7'-2" (2.21m)</u>
Bracing Material	<u>1" Sch.10</u>
Angle from Vertical	<u>60° Min.</u>
Least Rad. of Gyration	<u>0.43" (11mm)</u>
L/R Value	<u>200</u>
Maximum Horizontal Load	<u>2559 lbs. (1161kg.)</u>
Force Factor (Fp)	<u>0.5</u>

Tolco Brace Components	
Tolco Component Fig. Number	Adjusted Load
Fig.4L Clamp	1745 lbs. (792 kg.)
Fig.980 Universal Swivel	2395 lbs. (1086 kg.)
<small>*Calculation Based on CONCENTRIC Loading                      *Please Note: These calculations are for Tolco components only.                      Use of any other components voids these calculations and the listing of the assembly.</small>	

Fastener Information	
Fastener Orientation	<u>NFPA Type C</u>
Type	<u>Fig.800 Across Beam</u>
Diameter	<u>N/A</u>
Length	<u>N/A</u>
Maximum Load	<u>1745 lbs. (792kg.)</u>



Brace Identification on Plans	<u>LON6 2442</u>
Orientation of Brace	<u>Longitudinal</u>

## Load Information

Size and Type of Pipe	Total Length	Total Calculated Load
<u>6"(150mm) Schedule 10 Pipe</u>	<u>30 ft. (9.1m)</u>	<u>345 lbs. (157kg.)</u>
<u>Percentage added for Fittings and Sprinklers</u>	<u>15 %</u>	<u>52 lbs.(23.5kg.)</u>
<b>Total Adjusted Load of all pipe within Zone of Influence</b>		<b>397 lbs.(181kg.)</b>

(Tol-Brace Version 6.5.1)

# Tol-Brace Seismic Calculations

For

STENNIS RIVERINE  
STENNIS SPACE CENTER



Job #269-941989101

Brace Identification	LON6 2442
Brace Type (Per NFPA#13)	NFPA Type C
Spacing of Brace	30 ft.(9m)
Orientation of Brace	Longitudinal
Bracing Material	1" Sch.10
Length of Brace	7.1667ft. (2m)
Slenderness Ratio used for Load Calculation	200
True Angle of Brace for Calculation	60°
Type of Fastener	N/A In. Fig.800 Across Beam
Length of Fastener	N/A In.
Length of Fastener	N/A

## Summary of Pipe within Zone of Influence

6 inch Sch. 10	30 Feet (9m)
Allowance for Heads and Fittings	15%

## Conclusions

Total Adjusted Load of Pipe in Zone of Influence	397 lbs.(180kg.)
Material Capacity	2559.2780968651 lbs.(1161 kg.)
Fastener Capacity	1745 lbs.(792kg.)
Fig.4L Clamp	1745 lbs.(792kg.)
Fig.980 Universal Swivel	2395 lbs.(1086kg.)
Structural Member:	RIGID FRAME*

Calculations prepared by NANCY HINGLE

\*The description of the Structural Member is for informational purposes only.  
Tol-Brace software calculates the brace assembly only, not the structure it is attached to.  
Calculated with Tol-Brace 6.0 Fire  
visit us at [www.tolco.com](http://www.tolco.com)

# Tol-Brace Seismic Calculations

Project Address: STENNIS RIVERINE  
STENNIS SPACE CENTER  
STENNIS, MS  
 Job # 269-941989101

SimplexGrinnell  
 5800 Jefferson Hwy - Suite A  
 Harahan, LA 70123  
 504-613-1083



Calculations based on 2007 NFPA Pamphlet #13

Brace Information	Tolco Brace Components						
Maximum Spacing <u>30'-0" (9.24m)</u> Length of Brace <u>7'-0" (2.16m)</u> Bracing Material <u>1" Sch.40</u> Angle from Vertical <u>60° Min.</u> Least Rad. of Gyration <u>0.42" (11mm)</u> L/R Value <u>200</u> Maximum Horizontal Load <u>2124 lbs. (963kg.)</u> Force Factor (Fp) <u>0.5</u>	<table style="width: 100%;"> <tr> <th>Tolco Component Fig. Number</th> <th>Adjusted Load</th> </tr> <tr> <td>Fig.1000 Clamp</td> <td>1096 lbs. (497 kg.)</td> </tr> <tr> <td>Fig.980 Universal Swivel</td> <td>2395 lbs. (1086 kg.)</td> </tr> </table> <p><i>*Calculation Based on CONCENTRIC Loading                      *Please Note: These calculations are for Tolco components only.                      Use of any other components voids these calculations and the listing of the assembly.</i></p>	Tolco Component Fig. Number	Adjusted Load	Fig.1000 Clamp	1096 lbs. (497 kg.)	Fig.980 Universal Swivel	2395 lbs. (1086 kg.)
Tolco Component Fig. Number	Adjusted Load						
Fig.1000 Clamp	1096 lbs. (497 kg.)						
Fig.980 Universal Swivel	2395 lbs. (1086 kg.)						
	<h3>Assembly Detail</h3> <p style="text-align: right;">60° Min. From Vertical Detail #3244</p>						
<h3>Fastener Information</h3> Fastener Orientation <u>NFPA Type C</u> Type <u>Fig.800 Across Beam</u> Diameter <u>N/A</u> Length <u>N/A</u> Maximum Load <u>1745 lbs. (792kg.)</u>	<table style="width: 100%;"> <tr> <td>Brace Identification on Plans</td> <td>LAT7 2442</td> </tr> <tr> <td>Orientation of Brace</td> <td>Lateral</td> </tr> </table>	Brace Identification on Plans	LAT7 2442	Orientation of Brace	Lateral		
Brace Identification on Plans	LAT7 2442						
Orientation of Brace	Lateral						

## Load Information

Size and Type of Pipe	Total Length	Total Calculated Load
6"(150mm) Schedule 10 Pipe	30 ft. (9.1m)	345 lbs. (157kg.)
2"(50mm) Schedule 10 Pipe	44 ft. (13.4m)	93 lbs. (43kg.)
Percentage added for Fittings and Sprinklers	15 %	66 lbs.(29.82kg.)
<b>Total Adjusted Load of all pipe within Zone of Influence</b>		<b>504 lbs.(229kg.)</b>

(Tol-Brace Version 6.5.1)

# Tol-Brace Seismic Calculations

For

STENNIS RIVERINE  
STENNIS SPACE CENTER

Job #269-941989101



Brace Identification	LAT7 2442
Brace Type (Per NFPA#13)	NFPA Type C
Spacing of Brace	30 ft.(9m)
Orientation of Brace	Lateral
Bracing Material	1" Sch.40
Length of Brace	7ft. (2m)
Slenderness Ratio used for Load Calculation	200
True Angle of Brace for Calculation	60°
Type of Fastener	N/A In. Fig.800 Across Beam
Length of Fastener	N/A In.
Length of Fastener	N/A

## Summary of Pipe within Zone of Influence

6 inch Sch. 10	30 Feet (9m)
2 inch Sch. 10	44 Feet (13m)
Allowance for Heads and Fittings	15%

## Conclusions

Total Adjusted Load of Pipe in Zone of Influence	504 lbs.(229kg.)
Material Capacity	2124 lbs.(963kg.)
Fastener Capacity	1745 lbs.(792kg.)
Fig.1000 Clamp	1096 lbs.(497kg.)
Fig.980 Universal Swivel	2395 lbs.(1086kg.)
Structural Member:	RIGID FRAME*

Calculations prepared by NANCY HINGLE

\*The description of the Structural Member is for informational purposes only.  
Tol-Brace software calculates the brace assembly only, not the structure it is attached to.  
Calculated with Tol-Brace 6.0 Fire  
visit us at [www.tolco.com](http://www.tolco.com)

# Tol-Brace Seismic Calculations

Project Address: STENNIS RIVERINE  
STENNIS SPACE CENTER  
STENNIS, MS  
 Job # 269-941989101

SimplexGrinnell  
 5800 Jefferson Hwy - Suite A  
 Harahan, LA 70123  
 504-613-1083

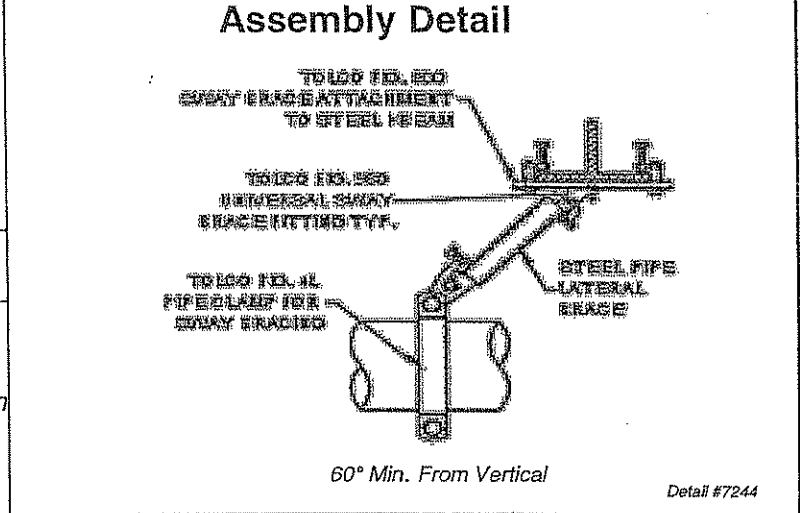


Calculations based on 2007 NFPA Pamphlet #13

Brace Information	
Maximum Spacing	<u>30'-0" (9.24m)</u>
Length of Brace	<u>7'-2" (2.21m)</u>
Bracing Material	<u>1" Sch.10</u>
Angle from Vertical	<u>60° Min.</u>
Least Rad. of Gyration	<u>0.43" (11mm)</u>
L/R Value	<u>200</u>
Maximum Horizontal Load	<u>2559 lbs. (1161kg.)</u>
Force Factor (Fp)	<u>0.5</u>

Fastener Information	
Fastener Orientation	<u>NFPA Type C</u>
Type	<u>Fig.800 Across Beam</u>
Diameter	<u>N/A</u>
Length	<u>N/A</u>
Maximum Load	<u>1745 lbs. (792kg.)</u>

Tolco Brace Components	
Tolco Component Fig. Number	Adjusted Load
Fig.4L Clamp	1745 lbs. (792 kg.)
Fig.980 Universal Swivel	2395 lbs. (1086 kg.)
*Calculation Based on CONCENTRIC Loading *Please Note: These calculations are for Tolco components only. Use of any other components voids these calculations and the listing of the assembly.	



Brace Identification on Plans	<u>LON7 2442</u>
Orientation of Brace	<u>Longitudinal</u>

## Load Information

Size and Type of Pipe	Total Length	Total Calculated Load
<u>6"(150mm) Schedule 10 Pipe</u>	<u>30 ft. (9.1m)</u>	<u>345 lbs. (157kg.)</u>
<u>Percentage added for Fittings and Sprinklers</u>	<u>15 %</u>	<u>52 lbs.(23.5kg.)</u>
<b>Total Adjusted Load of all pipe within Zone of Influence</b>		<u>397 lbs.(181kg.)</u>

(Tol-Brace Version 6.5.1)

# Tol-Brace Seismic Calculations

For

STENNIS RIVERINE  
STENNIS SPACE CENTER

Job #269-941989101



Brace Identification	LON7 2442
Brace Type (Per NFPA#13)	NFPA Type C
Spacing of Brace	30 ft.(9m)
Orientation of Brace	Longitudinal
Bracing Material	1" Sch.10
Length of Brace	7.1667ft. (2m)
Slenderness Ratio used for Load Calculation	200
True Angle of Brace for Calculation	60°
Type of Fastener	N/A In. Fig.800 Across Beam
Length of Fastener	N/A In.
Length of Fastener	N/A

## Summary of Pipe within Zone of Influence

6 inch Sch. 10	30 Feet (9m)
Allowance for Heads and Fittings	15%

## Conclusions

Total Adjusted Load of Pipe in Zone of Influence	397 lbs.(180kg.)
Material Capacity	2559.2780968651 lbs.(1161kg.)
Fastener Capacity	1745 lbs.(792kg.)
Fig.4L Clamp	1745 lbs.(792kg.)
Fig.980 Universal Swivel	2395 lbs.(1086kg.)
Structural Member:	RIGID FRAME*

Calculations prepared by NANCY HINGLE

\*The description of the Structural Member is for informational purposes only.  
Tol-Brace software calculates the brace assembly only, not the structure it is attached to.  
Calculated with Tol-Brace 6.0 Fire  
visit us at [www.tolco.com](http://www.tolco.com)