



PROTECTOR[®] LABORATORY FUME HOODS AND DUCTLESS ENCLOSURES



Protecting your
laboratory environment
LABCONCO



Protector® Laboratory Fume Hoods & Enclosures

Overview

Since the manufacture of our first product in 1925, the Kjeldahl Apparatus, Labconco has focused on finding effective ways to remove chemical fumes from the laboratory. That knowledge and experience led to the development of our first molded fiberglass-lined fume hoods in 1961. We continue to build on that expertise today as we refine our designs to exacting standards and adapt to the changing needs of the marketplace. The result is the broadest, most comprehensive and innovative line of laboratory ventilated enclosures available anywhere.

Labconco is ISO 9001 certified, one measure of our commitment to quality and consistency in design and manufacturing. We back our quality products with outstanding customer service. Whether you need a single fume hood and all its required system components, a unique custom-designed fume hood to handle a special application, or an entire building of fume hoods and supporting casework, Labconco technical specialists are ready to help you throughout the process. With our worldwide network of distributors, we are dedicated to providing quality products and service to meet your requirements and exceed your expectations.

Table of Contents

Overview	1
Chemical Fume Hoods and Enclosures Selection Guide	8
Carbon-Filtered Enclosures Selection Guide	10
Applicable Standards	11
Protector® Premier® Laboratory Hoods	12
Protector® XStream® Laboratory Hoods	20
Protector® XL™ Laboratory Hoods	26
Protector® XL™ Floor-Mounted Laboratory Hoods	32
Protector® XLE™ Laboratory Hoods	41
Protector® ClassMate® Laboratory Hoods	44
Protector® Pass-Through Laboratory Hoods	48
Protector® Stainless Steel Radioisotope Laboratory Hoods	52
Protector® Stainless Steel Perchloric Acid Laboratory Hoods	56
Protector® PVC Perchloric Acid & Acid Digestion Laboratory Hoods	60
Basic™ Laboratory Hoods	64
Fiberglass 30 Laboratory Hoods	70
Fume Adsorbers	72
Paramount® Ductless Enclosures	74
Paramount® Filters & Accessories	79
Paramount® Ductless Enclosures Accessories	81
Protector® XVS™ Ventilation Stations	82
FilterMate™ Portable Exhausters	86
Protector® Demonstration Hoods	88
Protector® Work Stations	90
Carbon and HEPA Filters	94
Protector® XVS Ventilation Stations, Protector Demonstration Hoods & Protector® Work Stations Accessories	96
Canopy Hoods	99
SpillStopper™ Work Surfaces	100
Flat Work Surfaces	104
Base Stands & Storage Cabinets Selection Guide	105
Protector® Acid Storage Cabinets	106
Protector® Solvent Storage Cabinets	108
Protector® Standard Storage Cabinets	110
Protector® Vacuum Pump Storage Cabinets	112
Telescoping Base Stands	113
Electric & Manual Hydraulic Lift Base Stands	114
ADA Stand	116
Accessories	117
Appendix: Advancing Laboratory Ventilation Technology	122
Index by Catalog Number	126
Conversion Factors	128
Blowers Booklet	Back Pocket





Protector® Laboratory Fume Hoods & Enclosures

Overview



Built To Exacting Standards

Protecting your laboratory environment is the foundation of our product development, and every Labconco fume hood and enclosure is designed with safety in mind. Our fume hoods are rigorously tested and conform to a long list of government and independent agency standards that specify safe construction and performance criteria for laboratory hoods:

- Occupational Health and Safety (OSHA) Federal Register 29 CFR Part 1910
- *Industrial Ventilation*, American Conference of Governmental Industrial Hygienists
- American Society of Heating, Refrigerating, and Air-Conditioning Engineers (ASHRAE) 110-1995
- ANSI Z9.5-2003
- Scientific Equipment & Furniture Association (SEFA) 1-2006
- National Fire Protection Association (NFPA) 45-2004
- American Society for Testing and Materials (ASTM) E84-09C
- Underwriters Laboratories (UL) 1805
- UL 3101-1/61010-1
- Canadian Standards Association (CAN/CSA) C22.2 No. 1010.1 & 61010-1
- European Community (CE)

Brief explanations of these standards can be found on page 11. Throughout the catalog, the specific regulations and standards met by each style of hood are provided in the ordering information.

To ensure that our hoods meet or exceed ASHRAE 110-1995, Labconco engineers rigorously test newly designed fume hoods and routinely test randomly-selected hoods from our product line in Labconco's Airflow Test Laboratory (see pages 122-125 for more information). Besides internal testing, many of our hoods undergo stringent testing and



As part of ASHRAE 110-95, a tracer gas is released at an established rate and at various positions within the hood. The gas is monitored in the breathing zone of a mannequin placed at various positions in front of the hood. Based on the release rate of the tracer gas and the average exposure in the breathing zone, a performance rating is determined. An "As Manufactured" (AM) rating of 0.05 part per million (ppm) or less is considered effective containment.

certification by an unbiased independent organization, Intertek Testing Services (ITS). ITS, which acquired ETL Testing Laboratories in 1996, is recognized by OSHA as a Nationally Recognized



Testing Laboratory (NRTL) just as UL, CSA and several other independent organizations are recognized. A federal law passed in 1988 established the NRTL program to eliminate provisions that explicitly required or implied that product certification be performed only by standard-writing companies such as UL. Since each NRTL must meet the same OSHA competency requirements, NRTLs recognized for the same product safety test standard are considered equivalent in the capability to certify to that standard. Labconco fume hoods with the ETL mark have been certified to UL 1805 and/or UL 3101-1/61010-1 and CAN/CSA Standard C22.2 No. 1010.1 & 61010-1. Products that bear the ETL mark are subjected to a comprehensive safety program that includes testing, listing, labeling and quarterly follow-up inspections.

For a current list of Labconco products bearing the ETL mark, go to www.etlsemko.com.



Labconco fume hoods designed for international 230 volt, 50 Hz operation carry the CE mark. The CE mark indicates that the product conforms to all safety and other directives/specifications presently required by the Council of European Communities. The CE mark was established in 1993 to standardize European countries' electrical directives into a single set of regulations, eliminating barriers to trade. Present rules require that products meet electrical safety requirements set for laboratory equipment and also pass electromagnetic emissions testing (interference signals being output by the product) and electromagnetic immunity testing (the product should not respond to outside electromagnetic interference signals). An independent outside agency tests and confirms Labconco hoods' conformity to electromagnetic emissions and immunity standards.

Protector®—first choice in hoods

The Protector line of laboratory hoods offers you choice. Protector Hoods run the gamut of styles that fit a full range of applications from general chemistry to perchloric acid use. Liner materials include one-piece molded fiberglass, fiberglass-reinforced composite panel, stainless steel, PVC and tempered safety glass. Whatever your laboratory situation demands, there's a Protector Laboratory Hood to meet your needs.





Protector® Laboratory Fume Hoods & Enclosures

Overview

Defining Features

Consistent among Protector Hoods are several defining features that set them apart from the rest. Sleek exteriors with durable glacier white epoxy coating complement laboratory casework and allow compatible mixing and matching of several hood types.

The unique **ergonomic air foil with Clean-Sweep™ openings** is patented.* The aerodynamic curve of the air foil allows air to sweep the work surface for maximum containment. Clean-Sweep openings pull inflow air from under the air foil so that clean air continually flows over the air foil creating a constant protective barrier that keeps contaminants away. In addition, should the operator inadvertently block the air flowing across the air foil, air continues to enter from beneath and through the Clean-Sweep openings.

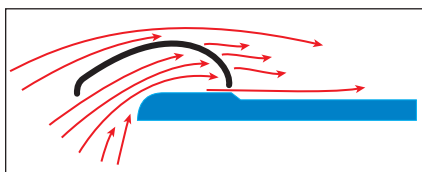

Side view of an air foil with Clean-Sweep openings illustrates airflow entering over, through and under the air foil.



When the operator blocks the front of the air foil, air enters from under the air foil so "dead-air" zones are minimized and containment maintained.

Protector **corner posts** have a streamlined shape to enhance containment and are epoxy-coated for chemical resistance. Switches and electrical receptacles mounted in the standard locations on the corner posts meet Americans with Disabilities Act (ADA) height requirements.

Color-coded service fixtures are also mounted at ADA height on the corner posts. Each service type has a sculpted, colored knob and matching interior-mounted hose connector for easy service identification and comfortable grip.

Access plates on the corner posts provide front availability to plumbing connections to simplify installation and service. Cover plates feature hood operating instructions, providing constant reminders to work safely in the hood.



Color-coded fixtures provide at-a-glance service type identification.

Protector Premier Laboratory Hoods—superior molded fiberglass liner

Protector Premier Laboratory Hoods feature interior liners molded of specially formulated fiberglass reinforced polyester. The one-piece, glossy fiberglass liner has



Front cover plates may be easily removed for quick access to service valves.

been the signature feature of Labconco's leading line of general chemistry fume hoods since its development by Labconco engineers in 1961. Benefits you can expect from fiberglass include durability, cleanability, high light reflectivity, fire resistance and chemical resistance.

Labconco fiberglass withstands exposure to a wide range of laboratory acids, solvents and alkalis. It will not absorb spills and resists staining and discoloration. The smooth one-piece surface with radiused corners has no cracks or crevices for contaminants to collect, so maintenance is minimal.

The chart of chemical resistance for Labconco fiberglass material shown below is based on ASTM Test C-581-00 in which 4" x 5" samples are immersed in reagents for one to three months or longer.

Fiberglass Chemical Resistance

Reagent	Satisfactory For Normal Use	Satisfactory For Occasional Use	Slight Discoloration with Heavy Use
Acetic Acid	●	●	
Acetone (50%)		●	
Ammonium Hydroxide		●	
Benzene		●	
Fatty Acids	●	●	
Formaldehyde (44%)		●	
Hydrochloric Acid	●	●	
Hydrofluoric Acid		●	●
Hydrogen Peroxide	●	●	●
Naphthalene	●	●	
Nitric Acid (35%)	●	●	●
Peracetic Acid	●	●	
Perchloric Acid	Use only in Protector Stainless Steel or PVC Perchloric Acid Hood.		
Petroleum Ether	●	●	
Phosphoric Acid	●	●	
Tannic Acid	●	●	
Sulfuric Acid (50%)	●	●	●

* U.S. Patent No. 6,461,233



Protector® Laboratory Fume Hoods & Enclosures

Overview

Protector XStream Laboratory Hoods—high performance and energy savings

The performance of a fume hood is measured by its ability to contain contaminants, i.e. its safety. No fume hood keeps contaminants contained better than Protector XStream Laboratory Hoods. Unlike other high performance, low flow, low volume hoods on the market, Protector XStream Laboratory Hoods do NOT rely on restricted sash openings, airflow sensors and electronic control, mechanical components or additional fans. Protector XStream Laboratory Hoods have patented* features that work together to significantly reduce the concentrations of contaminants in areas behind the sash opening,



A Protector XStream Laboratory Hood is installed along the wall. Protector XVS Ventilation Stations are mounted back-to-back on islands of casework.

© Mike Sinclair

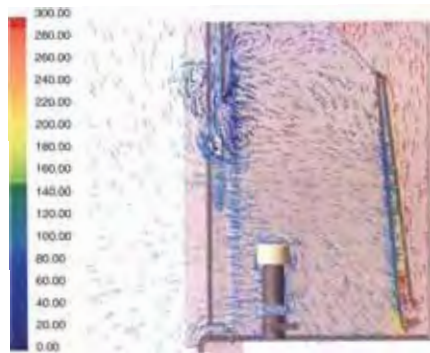

Figure 1: The Protector XStream Hood's velocity vector at 60 fpm is shown on a plane through the center of the hood. The horizontal laminar air vectors turn downward as they reach the perforated baffle. The Protector XStream Hood shows diminished vortex roll, thereby reducing air turbulence and instability in the hood.

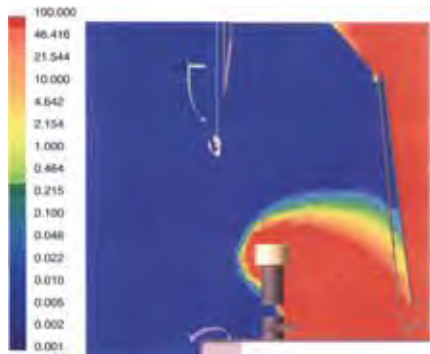

Figure 2: Sulfur hexafluoride (SF_6) gas is emitted from the ejector on a plane through the center of the hood at 4 liters per minute. The Protector XStream Hood is operating at 60 fpm with the sash fully open. The area near the sash plane where the operator would stand and work is dark blue indicating it is free of contaminants. The concentrations of contaminants, shown in orange, are contained deep within the interior of the hood so that contaminants can be exhausted in a single pass.

and near the user's breathing zone. These features include an upper dilution air supply that bathes the area behind the sash with clean air, *without the use of additional blowers*; an ergonomic air foil with Clean-Sweep openings that allow air to sweep the work surface; a rear downflow dual baffle system that directs airflow in non-turbulent laminar flow air streams to the back of the hood and counteracts the tendency for air inside a fume hood to roll forward; and a containment-enhancing sash handle that sweeps airflow into the hood with minimal turbulence.

To ensure that containment was maintained under adverse conditions, Labconco engineers developed variations of the ANSI/ASHRAE 110-1995 Standard to challenge the Protector XStream Hood. They tested the hood's containment limit by varying face velocities (as low as 40 fpm), differing sash heights and adding interior obstructions, cross drafts and door movements. In every instance, the Protector XStream showed tracer gas leakage below the acceptable ASHRAE level of less than 0.05 ppm. These worst-case conditions demonstrate the robust nature of the Protector XStream Hood.

To validate their successful ASHRAE test results, Labconco engineers used computational fluid dynamics (CFD) to build a model of the Protector XStream Hood. CFD predicts fluid flow behavior and provides a means of visualizing airflow. Like the tracer gas in ASHRAE testing, CFD was used as a tool to test the hood's performance. Design features were fine-tuned based on CFD test results until performance was optimized. The illustrations in Figures 1 and 2 are actual CFD outputs.

Protector XStream Laboratory Hoods are the clear choice when looking for energy savings without compromising safety. Operating these hoods at OSHA-approved 60 fpm provides significant energy savings compared to operating a traditional hood at 80 or 100 fpm and provides a comfortable margin of safety, confirmed by the adverse challenges these hoods withstood. In addition, because Protector XStream Hoods maintain containment, *regardless of sash position*, they may be installed with confidence in areas where users have poor, or unproven technique, such as teaching facilities with unsupervised student operators.

* U.S. Patent No. 6,461,233



Protector® Laboratory Fume Hoods & Enclosures

Overview

Protector XL Laboratory Hoods— broadest range of sizes and options

Protector XL Laboratory Hoods have a flexible platform for customization of features and dimensions. Their liners of durable fiberglass-reinforced composite panels may be configured in a variety of widths and depths to match architect specifications. Benchtop models are offered in widths from 4 to 16 feet and three depths.

Protector XLE Laboratory Hoods—enhanced safety features and energy savings

Protector XLE Laboratory Hoods feature a sash that automatically closes to an 18" sash opening to help conserve energy. Since the sash self-closes to a preset operating height and does not require a sash stop, sash position is not dependent on user compliance. In addition, these hoods have a viewing height of 35" and a low profile air foil with secondary spill trough, which enhances operator access to the interior. The spill trough does not add to the hood's overall height. Protector XLE Hoods are available in widths from 4' to 8', including 7' hoods.

Protector XL Floor-Mounted Laboratory Hoods— for maximum work area

Protector XL Floor-Mounted Laboratory Hoods have additional interior height to accommodate large apparatus. Hood interior depths from 30" to 48" and widths from 4' to 16' are available. Since they mount on the floor, these hoods permit roll-in loading of heavy or bulky apparatus.

Protector ClassMate Laboratory Hoods— for instructional laboratories

Patented* Protector ClassMate Laboratory Hoods have clear sides, back and baffle for visibility from all sides. A stationary glass viewing panel above the sash frame creates a 39" viewing height. They are ideal for advanced educational settings where students need to observe demonstrations conducted in the hood or the instructor needs to supervise students using the hood.



Transparent glass backs and baffles provide a clear view through these Protector ClassMate Combination Sash Laboratory Hoods mounted back-to-back on peninsular casework at this university laboratory.

© Mike Sinclair

Protector Pass-Through Laboratory Hoods—access on two sides

Protector Pass-Through Laboratory Hoods are designed for in-wall installation between two laboratories or for an island or peninsular configuration. Sashes on two sides allow access and visibility from either side. To maintain a safe airflow velocity, only one sash may be opened at a time — an audible alarm sounds when both sashes are opened simultaneously.

Protector Special Application Laboratory Hoods— for radioisotope, perchloric acid or heavy acid use

Applications involving radioisotopes, perchloric acid and acid digestion require laboratory hoods with specialized features. Protector Stainless Steel Radioisotope Hoods have integral welded work surfaces and coved interiors to facilitate decontamination. Labconco offers two perchloric acid hoods: the Protector Stainless Steel Perchloric Acid Hood and the Protector PVC Perchloric Acid Hood. These hoods feature washdown systems, integral work surfaces and drainage troughs so that they may be thoroughly

rinsed after each use to prevent the accumulation of potentially reactive perchloric salts. Protector PVC Acid Digestion Hoods feature Lexan** sashes, recommended for hydrofluoric acid use.

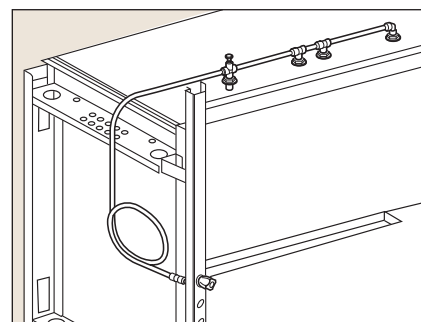

Protector Perchloric Acid and Acid Digestion Hoods feature a built-in washdown system consisting of plumbing connected to a control knob and spray nozzles located along the top interior.

Labconco offers you choices

The discussion that follows provides some of the factors to consider when choosing a laboratory ventilation system. The Selection Guides on pages 8-10 provide an at-a-glance listing of the fume hoods, ventilated enclosures and carbon-filtered enclosures offered in this catalog. The Guides help you find the Labconco fume hoods and enclosures with the characteristics you require for your system.

* U.S. Design Patent No. 472,645

**Lexan® is a registered trademark of General Electric Company.



Protector® Laboratory Fume Hoods & Enclosures

Overview

Types of Exhaust Systems

Fume hoods use one of two types of exhaust systems: constant air volume (CAV) or variable air volume (VAV). The fume hoods offered in this catalog have been designed to be used with a constant volume system and can be easily modified for use with a variable air volume system. Contact Labconco for ordering information on variable air volume modifications.

Constant volume hoods come in conventional, by-pass and auxiliary-air types. All Labconco fume hoods feature by-pass airflow design. Protector Premier for use with remote blower, and XL Laboratory Hoods may be modified to an auxiliary-air design with an accessory Auxiliary-Air Plenum Kit (see page 120).

By-Pass

By-pass hoods have a movable, fully-closing front sash and an interior baffle. These hoods are designed so that as the sash is being closed, the air entering the hood is redistributed via by-pass openings above and below the sash. These openings help to stabilize airflow

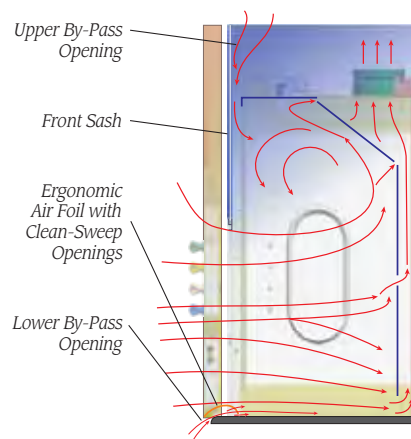

By-Pass Airflow Design

and eliminate high velocity air streams that can disturb delicate procedures or instrumentation in the hood. All Protector Premier, XStream, XL, XLE, Stainless Steel and PVC Hoods as well as Basic and Fiberglass 30 Hoods incorporate the by-pass feature.

Size

Labconco offers hoods in a range of sizes from compact 24" wide Protector XVS Ventilation Stations and 30" wide Fiberglass 30 Laboratory Hoods to Protector XL Laboratory Hoods as wide as 16 feet. OSHA 29 CFR-1910 recommends laboratories provide an average of 2.5 linear feet of hood space per person.

Sash Configuration

Most Labconco Hoods have vertical-rising sashes. **Vertical-rising** sashes may be lifted to the completely open position offering the maximum area for loading materials and apparatus. During operation, the sash should be lowered as much as possible to a comfortable working height to provide a barrier to protect the user from splashes and chemical reactions.

Horizontal-sliding sashes allow the user to reach around both sides of the sash while using the sash as a shield. Horizontal-sliding sashes provide a smaller maximum sash opening, approximately one-half the size of vertical-rising sashes. Because their sash openings are smaller and less air volume is exhausted, hoods with horizontal-sliding sashes conserve energy. Protector XL Floor-Mounted Hoods in widths from 8 to 16 feet have horizontal-sliding sashes.

Pivoting sashes are found on Protector Demonstration Hoods, Paramount Ductless Enclosures, Protector XVS Ventilation Stations and Protector Work Stations. These enclosures have a small permanent sash opening height that restricts energy usage. The sashes may not be fully closed but may be pivoted up to a full open position for loading of materials.

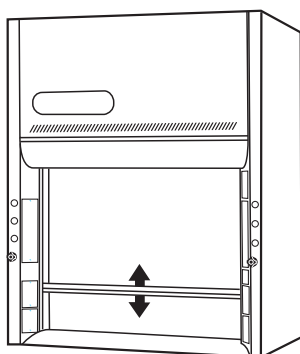

Vertical-rising sash

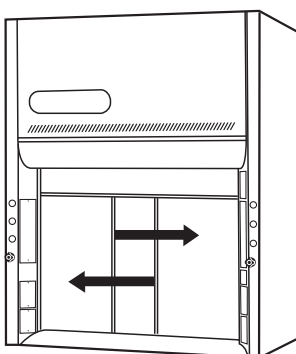

Horizontal-sliding sashes

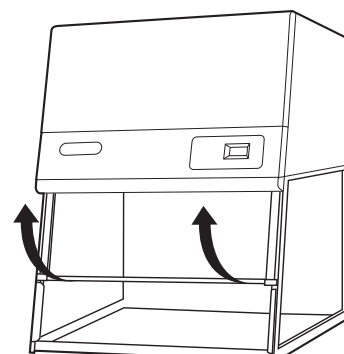

Pivoting sash
(See Combination Sash next page)



Protector® Laboratory Fume Hoods & Enclosures

Overview

Combination vertical-rising/horizontal-sliding sashes offer the advantages of both sash types. For energy conservation, the hood's air volume is based on its smaller horizontal-sliding sash opening (generally 50% of the full open position). To maintain safe face velocities, sash stops limit opening the vertical-rising sash beyond 50% except when deliberately released by the operator during loading or unloading. Some models of Protector ClassMate Hoods have combination sashes. Combination sashes on other hood models are available upon request.

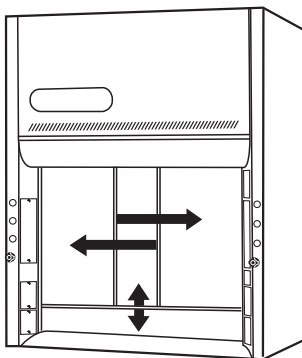

Combination vertical-rising/horizontal-sliding sashes.



The Protector XL Benchtop Laboratory Hoods installed in this laboratory feature combination vertical-rising/horizontal-sliding sashes.

Remote Blower vs. Built-In Blower

Most laboratory hoods are designed for use with remotely-located blowers. Of all the components required to complete a laboratory hood ventilation system, the blower is the most crucial to the hood's performance. Labconco offers a variety of blowers and exhaust devices sized for our hoods. The Blowers Booklet located in the back pocket of this catalog provides further information on our Coated Steel, Fiberglass and PVC Blowers, and Ductwork.

Selected models of Protector Premier Hoods in 4', 5' and 6' widths, Basic Hoods, Fiberglass 30 Hoods and some carbon-filtered enclosures have built-in blowers. Easy to install, these hoods feature blowers sized to accommodate relatively short, uncomplicated duct runs. Contact Labconco at **800-821-5525** or **816-333-8811** for technical assistance regarding the use of hoods with built-in blowers.



The built-in blower in this Protector Premier Laboratory Hood is visible when the front panel is removed.

Liner Material

Labconco offers a variety of liner materials. Protector Premier and Fiberglass 30 Laboratory Hoods are lined with molded, one-piece fiberglass. Protector XStream, XL and XLE Hoods have fiberglass-reinforced composite panel liners. Protector Radioisotope and Perchloric Acid Hoods have stainless steel liners. Other Protector Perchloric Acid and Acid Digestion Hoods have PVC liners. Protector ClassMate Laboratory Hoods, Pass-Through Hoods, XVS Ventilation Stations, Protector Demonstration Hoods, Paramount Ductless Enclosures and

Protector Work Stations have interiors that use tempered safety glass and epoxy-coated steel and aluminum channel construction. Basic Laboratory Hoods are epoxy-coated steel inside and out.

The best liner material for your hood should be determined by the applications, types and concentrations of chemicals that will be handled in the hood and exhaust system. Hood liners are subject to attack from acid fumes and solvent vapors by: (1) corrosion (the destruction of metal or other material by chemical or electrochemical action), (2) dissolution (a dissolving action to which coatings and plastics are subject), and (3) melting (occurs with certain plastics and coatings at elevated operating temperatures). The Hood Liner Materials table on page 7 describes the characteristics of the various liner materials found in Labconco hoods and enclosures to help you select the right ventilation product for your application.



Protector® Laboratory Fume Hoods & Enclosures

Overview

Hood Liner Materials

Liner Material	Stain Resistance	Moisture Resistance	Chemical Resistance	Heat Resistance	Flame Spread Index*
One-piece, molded fiberglass	Good	Excellent	Excellent	Very good	≤25
Fiberglass-reinforced composite panel	Good	Excellent	Excellent	Very good	≤25
Tempered safety glass	Excellent	Excellent	Excellent	Very good	0
Stainless steel (Type 316 or 304)	Good	Excellent	Good resistance to a wide range, subject to attack by some acids	Excellent	0
Polyvinyl chloride (PVC)	Very good	Excellent	Excellent except for some solvents	Poor. Distorts at 160° F. Usable at 140° F.	≤20
Epoxy-coated steel	Good	Very good	Good	Very good	≤5

* The lower a material's flame spread index, the greater its flame-retarding capabilities. NFPA 45 Standard on Fire Protection for Laboratories Using Chemicals states that materials of construction should have flame spread of 25 or less. The flame spread index is determined using ASTM E84 test method which compares the surface flame spread and smoke development measurements of a particular material to those obtained from tests of standard calibration materials at the opposite ends of the spectrum — mineral fiber cement board (flame spread index = 0) and select grade red oak flooring (smoke spread index = 100). The test specimen surface, 18" wide x 24" long, is exposed to a flaming fire for 10 minutes. Flame spread over its surface is measured and recorded. Test results are presented as the computed comparisons to the standard calibration materials.

Ducted Hoods vs. Ductless Carbon-Filtered Enclosures

Protector, Basic, Fiberglass 30 and Canopy Hoods, Protector XVS Ventilation Stations and some models of Protector Work Stations and Protector Demonstration Hoods require ducting to the outside so that contaminants can be dispersed and diluted above the roofline. Ducting to the



Since Paramount Ductless Enclosures require no ducting to the outside, they have the flexibility to be placed in hard-to-vent areas and may be moved from laboratory to storage when necessary.

outside provides the safest means to ensure that contaminants are removed from the laboratory. Other Labconco enclosures, such as the Protector XVS Ventilation Stations and Protector Demonstrations Hoods with FilterMate Portable Exhausters, Paramount Ductless Enclosures, Protector Work Stations and Fume Adsorbers, return filtered exhaust air back to the laboratory. These enclosures rely on specially treated or activated carbon media that treat or adsorb chemical gases including certain organic solvents, ammonia, acids and formaldehyde. Paramount Ductless Enclosures and some models of Protector XVS Ventilation Stations with FilterMate may use both carbon and HEPA filters. These enclosures are suitable for applications that create both gaseous and particulate contaminants.

Filtered enclosures provide a practical solution for situations where ducting is not feasible, such as laboratories surrounded by interior walls and located several stories from the roof. Filtered enclosures are appropriate for light duty chemical work in air-starved laboratories where make-up air is unavailable. When

placed on mobile stands, they become portable stations that can be shared by several laboratories or easily moved out of the way for storage.

Whether or not a carbon-filtered enclosure is the right ventilation product for your application requires consideration of factors such as the time-weighted exposure limits of your materials. Using Labconco's exclusive chemical assessment program, our technical specialists can help you determine the right product for your application. To begin the process, please complete the Chemical Usage Assessment Form available at www.labconco.com. In addition, an online Chemical Guide allows users to search individual chemicals to determine their suitability for use in a carbon-filtered enclosure.

In-depth Laboratory Hood System Information Available

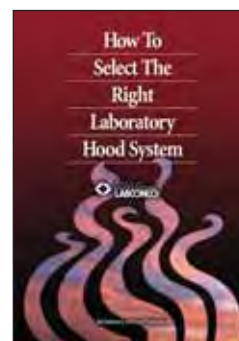

The preceding discussion on the many fume hood options available provides an overview to the detailed ordering information on specific hoods, enclosures, base cabinets, stands, work surfaces and accessories that follows. For an in-depth generic discussion on various hood selection considerations and choices, Labconco offers the *How To Select The Right Laboratory Hood System* booklet.

Please call **800-821-5525** or **816-333-8811** or visit www.labconco.com for your free copy of this informative guide.



Protector® Laboratory Fume Hoods & Enclosures

Selection Guide

Chemical Fume Hoods and

Product	Applications/Considerations	Liner Material	Nominal Exterior Widths
Protector Premier	Broad range for general chemistry	One-piece molded fiberglass	4', 5', 6', 8'
Protector XStream	Broad range for general chemistry, Energy savings, Enhanced containment	Fiberglass-reinforced composite panel	4', 5', 6', 8'
Protector XL Benchtop	Broad range for general chemistry	Fiberglass-reinforced composite panel	4', 5', 6', 8', 10', 12', 16'
Protector XL Floor-Mounted	Broad range for general chemistry, large apparatus and processes	Fiberglass-reinforced composite panel	4', 5', 6', 8', 10', 12', 16'
Protector XLE	Broad range for general chemistry, Energy savings	Fiberglass-reinforced composite panel	4', 5', 6', 7', 8'
Protector ClassMate	Instruction, Demonstration	Tempered safety glass, Epoxy-coated steel	4', 5', 6'
Protector Pass-Through	Instruction, Demonstration	Fiberglass-reinforced composite panel, Tempered safety glass	4', 5', 6'
Protector Stainless Steel Radioisotope	Low level radiochemistry	Type 304 stainless steel	4', 5', 6', 8'
Protector Stainless Steel Perchloric Acid	Perchloric acid	Type 316 stainless steel	4', 5', 6', 8'
Protector PVC Perchloric Acid	Perchloric acid	PVC	4', 6', 8"
Protector PVC Acid Digestion	Acid digestion, Hydrofluoric acid	PVC	4', 6', 8"
Basic	Light duty general chemistry, Organic chemistry	Epoxy-coated steel	4', 6'
Fiberglass 30	General chemistry	One-piece molded fiberglass	30"
Protector XVS Ventilation Station	Light duty chemistry/weighing, Instruction, Organic chemistry	Tempered safety glass, Epoxy-coated aluminum and steel	2', 3', 4', 5', 6', 8'
Protector Demonstration	Low-toxicity, Instruction, Demonstration	Tempered safety glass, Epoxy-coated aluminum	3'
Protector Work Station	Histology, Pathology, Tissue grossing, Staining, Organic chemistry	Type 304 stainless steel, Tempered safety glass, Epoxy-coated aluminum	4'



Protector® Laboratory Fume Hoods & Enclosures
Selection Guide

Enclosures Selection Guide

Interior Depths	Blower Options	Auxiliary-Air	Sash Configurations	Pages
23.5"	Remote, built-in	Available on some models	Vertical-rising*	12-19
27.3"	Remote	—	Vertical-rising*	20-25
24", 30", 36"	Remote	Available on some models	Vertical-rising*	26-31, 37-38
30", 36", 48"	Remote	—	Vertical-rising, Horizontal-sliding	32-36, 39-40
30"***	Remote	—	Vertical-rising	41-43
25.75", 26.25"	Remote	—	Vertical-rising, Combination	44-47
23.75"	Remote	—	Vertical-rising	48-51
23.5"***	Dedicated remote	—	Vertical-rising	52-55
23.5"***	Dedicated remote	—	Vertical-rising	56-59
30"	Dedicated remote	—	Vertical-rising	60-63
30"	Dedicated remote	—	Vertical-rising	60-63
18.44"	Remote, Built-in	—	Vertical-rising	64-69
22.67"	Remote, Built-in	—	Vertical-rising	70-71
23"	Remote, FilterMate Portable Exhauster	—	Pivoting with permanent 8" or 10" opening	82-85
23.4", 30.00"	Remote, FilterMate Portable Exhauster	—	Pivoting with permanent 8", 10" or 12" opening	88-89
23"	Remote	—	Pivoting with permanent 8" opening	90-93

* Contact Labconco at 800-821-5525 or 816-333-8811 for or dering information on hoods with combination sashes.

** Contact Labconco at 800-821-5525 or 816-333-8811 for or dering information on hoods with other depths.



Protector® Laboratory Fume Hoods & Enclosures

Selection Guide

Carbon-Filtered Enclosures Selection Guide

Product	Filter Types	Applications	Carbon Filter Capacity	Liner Materials	Nominal Exterior Widths	Interior Depth	Pages
Paramount Ductless Enclosure	Organic Carbon	Histology/cytology, Soldering, Solvent cleaning, Welding & gluing	7.5 lbs.*	Tempered safety glass, Epoxy-coated aluminum & steel	2', 3', 4', 5', 6'	23.4" or 30.0"	74-81
	Acid-Sulfur Carbon	Acid pouring & mixing	10 lbs.*				
	Ammonia-Amine Carbon	Fertilizer research	11 lbs.*				
	Formaldehyde Carbon	Endoscopy instrument cleaning, Pathology/tissue grossing	10 lbs.*				
	Radioisotope Carbon	Iodine isotope handling	10 lbs.*				
	Mixed Bed Carbon	Science education, Additional applications suitable to the carbon filter type	10 lbs.*				
Protector XVS Ventilation Station or Protector Demonstration Hood with FilterMate Portable Exhauster	Organic Carbon	Histology/cytology Soldering, Solvent cleaning, Welding & gluing	12 lbs. (1 or 2 each required)	Tempered safety glass, Epoxy-coated aluminum	2', 3', 4'	23.0"	82-89, 94-95
	Ammonia Carbon	Photoengraving, Plastics production	16 lbs. (1 or 2 each required)				
	Formaldehyde Carbon	Endoscopy instrument cleaning, Pathology	14 lbs. (1 or 2 each required)				
	Carbon/HEPA	Cleanroom, Critical environments, Combination dry & liquid chemicals, Non-hazardous microbes with trace chemicals, Pathology, Soldering, Solvent cleaning	Varies				
Protector Work Station	Organic Carbon	Histology/cytology	11 lbs. (2 each required)	Type 304 stainless steel, Tempered safety glass, Epoxy-coated steel	4'	23.0"	90-95
	Formaldehyde Carbon	Pathology	13 lbs. (2 each required)				
	Ammonia Carbon	Photoengraving, Plastics Production	15 lbs. (2 each required)				
Fume Adsorber/ Fume Adsorber-2	Organic Carbon	Histology/cytology	6 lbs./12 lbs.	Acrylic, Epoxy-coated steel	30", 60"	14.5"	72-73
	Formaldehyde Carbon	Pathology	7.5 lbs./15 lbs.				
	Ammonia Carbon	Photoengraving	8.8 lbs./17.6 lbs.				

*Two each to eight each filters required depending on the model.



Protector® Laboratory Fume Hoods & Enclosures

Applicable Standards

Key aspects of standards and codes as they relate to laboratory ventilation are summarized below.

Federal Register 29 CFR Part 1910

Occupational exposure to hazardous chemicals in laboratories

National Research Council Recommendations Concerning Chemical Hygiene in Laboratories (Non-mandatory) from "Prudent Practices."

- Fume hoods should have a continuous monitoring device.
- Face velocities should be between 60-100 linear feet per minute (lfpm).
- Average 2.5 linear feet of hood space per person.

Occupational Safety & Health Administration U.S. Department of Labor

200 Constitution Avenue, NW
Washington, DC 20210
(800) 321-6742
www.osha.gov

Industrial Ventilation-ACGIH

- Fume hood face velocities between 60-100 lfpm.
- Maximum of 125 lfpm for radioisotope hoods.
- Duct velocities of 1000-2000 fpm for vapors, gases and smoke.
- Stack discharge height 1.3-2.0 x building height.
- Well designed fume hood containment, loss <0.10 ppm.

Industrial Ventilation:

A Manual of Recommended Practice
27th Edition, 2010

American Conference of Governmental Industrial Hygienists

1330 Kemper Meadow Drive
Cincinnati, OH 45240
(513) 742-2020
www.acgih.org

ASHRAE 110-1995 Method of Testing Performance of Laboratory Fume Hoods (ANSI Approved)

Evaluates fume hood's containment characteristics

- Three part test: Smoke generation, face velocity profile, tracer gas release @ 4 liters per minute.
- Rated As Manufactured (AM), As Installed (AI) and As Used (AU).

American Society of Heating, Refrigerating and Air-Conditioning Engineers

1791 Tullie Circle NE
Atlanta, GA 30329
(404) 636-8400
www.ashrae.org

ANSI Z9.5-2003 Standard—Laboratory Ventilation

Covers entire laboratory ventilation system.

- Vertical stack discharge @ 2000-3000 fpm.
- New and remodeled hoods shall have a monitoring device.
- Ductless hoods should only be used with non-hazardous materials.

American Industrial Hygiene Association

2700 Prosperity Avenue, Suite 250
Fairfax, VA 22031
(703) 849-8888
www.aiha.org

SEFA 1-2006 Laboratory Fume Hoods Recommended Practices

- Fume hood face velocities based on toxicity levels of chemicals.
Class A — materials of extreme toxicity — 125 to 150 fpm.
Class B — standard lab chemicals — 80 to 100 fpm.
Class C — materials of low toxicity — 75 to 80 fpm.
- Test method — face velocity profile and smoke generation.

Scientific Equipment & Furniture Association

1205 Franklin Avenue
Suite 320
Garden City, NY 11530
(516) 294-5424
www.sefalabs.com

NFPA 45: Standard on Fire Protection for Laboratories Using Chemicals, 2004 Edition

- Laboratory hoods should not be relied on for explosion protection.
- Fume hood exhaust air should not be recirculated.
- Services should be external to the hood.
- Canopy hoods only for non-hazardous applications.
- Materials of construction should have flame spread of 25 or less.

National Fire Protection Association

1 Batterymarch Park
Quincy, MA 02169-7471
(800) 344-3555 or (617) 770-3000
www.nfpa.org

ASTM E84-09C Standard Test Method for Surface Burning Characteristics of Building Materials

Determines the relative burning behavior of the material by observing the flame spread along the specimen.

- Measures flame spread and smoke development.
- Material is exposed to flaming fire for 10 minutes and the results measured and recorded.
- Results are compared to the indexes of mineral fiber cement board (flame spread and smoke development of zero) and red oak flooring (smoke development of 100).

ASTM International

100 Barr Harbor Drive
P.O. Box C700
West Conshohocken, PA 19428-2959
(610) 832-9585
www.astm.org

UL 1805—Standard for Laboratory Hoods and Cabinets

- Hood interior constructed of nonflammable, corrosion and chemical-resistant materials.
- Counterbalanced sash of non-shattering material.
- Shielded by-pass opening.

- Dished work surface to contain spills.
- No air recirculation.
- Integral blower wheel of nonsparking materials.
- Externally-mounted electrical receptacles, light fixtures and service fixture controls.
- No indication of reverse flow or backflow when tested with sash at full, 2/3 and 1/3 open positions at flow rate recommended by the manufacturer.

UL 61010-1 (formerly 3101-1) Electrical Equipment for Laboratory Use

Specifies the general safety requirements for electrical equipment

- Based on International Electrotechnical Commission (IEC) Publication 61010-1 with differences noted for U.S. use.
- Tests for protection against electrical shock, mechanical hazards, spread of fire, radiation, liberated gases, explosion and implosion.
- Tests for resistance to shock, vibration, impact, heat, moisture and liquids.

Underwriters Laboratories Inc.

333 Pfingsten Road
Northbrook, IL 60062-2096
(847) 272-8800
www.ul.com

CAN/CSA Standard C22.2 No. 1010.1-92 & No. 61010-1 Safety Requirements for Electrical Equipment for Measurement, Control and Laboratory Use

Specifies general safety requirements for electrical equipment

- Design and methods of construction should provide adequate protection to the operator and the surrounding area against shock or burn, mechanical hazards, excessive temperature, spread of fire from the equipment, gas liberation, explosion or implosion.

Canadian Standards Association

5060 Spectrum Way, Suite 100
Mississauga, Ontario
L4W 5N6
CANADA
(800) 463-6727 or (416) 747-4044
www.csa.ca

CE Marking

Established in 1993 to standardize the European Community's electrical directives into a single set of regulations. Indicates an electrical apparatus conforms to all safety and other directives/specifications presently required by the Council of European Communities.

- Electrical safety.
- Electromagnetic emissions testing — interference signals being output by the product.
- Electromagnetic immunity testing — the product does not respond to outside electromagnetic interference signals.

European Union

www.europa.eu



4' Protector Premier Laboratory Hood 4880400 is shown with SpillStopper Work Surface 9847100 and Protector Solvent Storage Cabinet 9902000.



Requires
Ductwork and
Blower



Protector® Premier® Laboratory Hoods

Features & Benefits

Protector® Premier™ Laboratory Hoods incorporate a sleek exterior with a molded one-piece fiberglass liner, the signature feature of Labconco's leading line of fume hoods since 1961.

The one-piece liner of specially-formulated, fiberglass-reinforced polyester offers corrosion and fire resistance and easy clean up.

Protector Premier Laboratory Hoods are offered in 4', 5', 6' and 8' widths so their dimensions exactly match standard laboratory casework or accessory Protector Base Cabinets and Stands.

Choose from hoods designed to be used with a remotely-located blower or hoods that include a built-in blower.

Models with built-in blower are available. Quiet built-in blower is belt-driven with molded thermoplastic housing and coated aluminum impeller that is non-sparking and corrosion-resistant. Available with explosion-proof or standard motor.

Fluorescent lighting illuminates the interior. The high efficiency, instant start, T8 fluorescent lights are located outside the hood interior for corrosion-resistance and easy replacement. Explosion-proof models are supplied with an incandescent light fixture.

Color-coded service fixtures for gas, air, water, vacuum and other services have remote controls for use regardless of the sash position. Two service fixtures are pre-plumbed on fixtured models. Each hood is factory prepared for up to eight service fixtures (four on each side).

ETL-listed. Hoods carry the ETL mark signifying that they are certified to UL 3101-1/61010-1, UL 1805 and CAN/CSA C22.2 No. 1010.1.



Front and side panels may be easily removed for lamp replacement and access to electrical supply connections.

By-pass airflow design ensures stable face velocities that meet or exceed established standards.

Corrosion-resistant, molded fiberglass exhaust connection(s) on models for use with remote blowers.

Pre-set baffle provides a uniform face velocity pattern across the sash opening of the hood.

Large 28" sash opening offers superior viewing. When fully open, the sash does not extend above the hood.

Vertical-rising tempered safety glass sash is anti-racking for smooth operation. Contact Labconco for ordering information on horizontal-sliding or combination sashes.

Service access panels allow accessibility to plumbing from the front of the hood.

One-piece molded fiberglass liner gives superior corrosion and chemical resistance, durability and light reflectivity. Its smooth, radiused corners make cleaning easy.

Pre-wired electrical components. Fluorescent lights and switches are factory-wired to the hood's single point junction box. One electrical duplex receptacle is factory-wired on 115 volt, 60 Hz fixtured models. Each hood is factory-prepared for up to four electrical duplexes and an air-flow monitor. **Explosion-proof models are furnished without switches, electrical receptacle and wiring as these must conform to varying local codes.**

Performance tested to ASHRAE 110-1995.

Ergonomic air foil allows air to sweep the work surface for maximum containment. Clean-Sweep* airflow openings pull inflow air from under the air foil so that clean air continually flows over the air foil creating a constant barrier of protection from contaminants.

Durable and attractive exterior is glacier white, dry powder epoxy-coated steel.

CE mark. All 230 volt, 50 Hz models conform to the CE (European Community) requirements for electrical safety and electromagnetic compatibility.



Exclusive Feature

*U.S. Patent No. 6,461,233



Protector® Premier® Laboratory Hoods

for use with remote blower



- One pre-wired 115 volt, 20 amp electrical duplex receptacle on lower right side (115 volt models)

All models require (not included):

- **Remote Blower.** See back pocket.
- **Ductwork.** See back pocket.
- **Work Surface.** See pages 100-104.
- **Base Cabinet or Stand.** See pages 106-116.

Optional accessories for on-site installation include:

- **Service Fixture Kits.** See page 117.
- **Electrical Duplex Kits.** See page 118.
- **Guardian Airflow Monitor Kits.** See page 118.
- **Ceiling Enclosure and Rear Finish Panel Kits.** See pages 119-120.
- **Distillation Grid Kits.** See page 120.
- **Auxiliary-Air Kits.** See page 120.
- **Sash Stop Kits.** See page 121.
- **Snuffer Fire Extinguishers.** See page 121.

Contact Labconco at **800-821-5525** or **816-333-8811** for ordering information on explosion-proof lighting and other sash configurations and for blower sizing assistance.

With Sash Full Open (28")				
Nominal Width	Total Exhaust CFM and Static Pressure			
	100 fpm	S.P.	80 fpm	S.P.
4 Feet	730	0.17"	590	0.11"
5 Feet	960	0.24"	770	0.16"
6 Feet	1180	0.31"	940	0.20"
8 Feet	1660	0.22"	1330	0.15"

With Sash 60% Open (18")**				
Nominal Width	Total Exhaust CFM and Static Pressure			
	100 fpm	S.P.	80 fpm	S.P.
4 Feet	470	0.07"	380	0.05"
5 Feet	610	0.11"	490	0.08"
6 Feet	750	0.14"	600	0.09"
8 Feet	1060	0.08"	850	0.06"

* U.S. Patent No. 6,461,233
 ** Sash stop required

Heights of switches, electrical receptacle and service fixtures meet requirements of ADA.

All models feature:

- By-pass airflow design.
- Ergonomic air foil with aerodynamic Clean-Sweep* airflow openings.
- Glacier white, dry powder epoxy-coated steel exterior.
- One-piece molded fiberglass liner and pre-set baffle(s) with flame spread less than 25 per ASTM E-84.
- 3/16" thick tempered safety glass vertical-rising sash(es) with epoxy-coated sash handle. Sash does not extend above the hood when fully open.
- Removable front and side panels and front access panels for access to plumbing and electrical wiring.
- Pre-wired T8 fluorescent lighting, light and blower switches.
- Molded fiberglass 12.81" ID exhaust connection(s).

Exclusive Feature

All models conform to the following regulations and standards:

- SEFA 1-2006
- NFPA 45-2004
- ASTM E84-09C
- ASHRAE 110-95
- ANSI Z9.5-2003
- UL 3101-1/61010-1
- CAN/CSA C22.2 No. 1010.1
- UL 1805
- CE Conformity Marking (230 volt models)

Fixed models feature:

- Two pre-plumbed service fixtures with forged brass valves, lower right side with brass tubing for gas and lower left side with copper tubing for cold water. Components for converting either or both fixtures to air and vacuum are provided. **Inlet tubing is not provided.**



Ordering Information

Protector® Premier® Laboratory Hoods for use with remote blower

Nominal Width	Catalog Number	Electrical Requirements	12.81" (32.5 cm) ID Exhaust Collar(s)	Sash	Fluorescent Lamps	Service Fixtures	Electrical Duplex	Shipping Weight lbs./kg
4 Feet	4880100	115 volts, 60 Hz	1	1	2 ea. 25 watt	None	None	325/147
	4880400	115 volts, 60 Hz	1	1	2 ea. 25 watt	2	1	335/152
	4871500*	230 volts, 50 Hz	1	1	2 ea. 25 watt	None	None	325/147
	4871600*	230 volts, 50 Hz	1	1	2 ea. 25 watt	2	None	335/152
5 Feet	6080100	115 volts, 60 Hz	1	1	2 ea. 32 watt	None	None	410/186
	6080400	115 volts, 60 Hz	1	1	2 ea. 32 watt	2	1	420/191
	6071500*	230 volts, 50 Hz	1	1	2 ea. 32 watt	None	None	410/186
	6071600*	230 volts, 50 Hz	1	1	2 ea. 32 watt	2	None	420/191
6 Feet	7280100	115 volts, 60 Hz	1	1	2 ea. 32 watt	None	None	485/220
	7280400	115 volts, 60 Hz	1	1	2 ea. 32 watt	2	1	495/225
	7271500*	230 volts, 50 Hz	1	1	2 ea. 32 watt	None	None	485/220
	7271600*	230 volts, 50 Hz	1	1	2 ea. 32 watt	2	None	495/225
8 Feet	9683000	115 volts, 60 Hz	2	2	4 ea. 25 watt	2	1	660/299
	9674500*	230 volts, 50 Hz	2	2	4 ea. 25 watt	2	None	660/299

*International electrical configuration

4 Feet

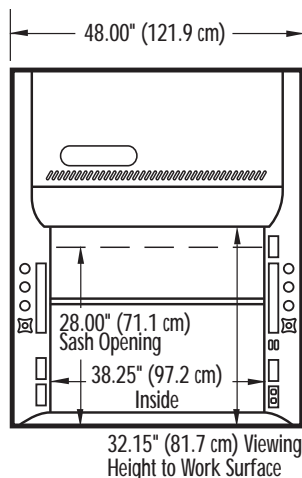

5 Feet

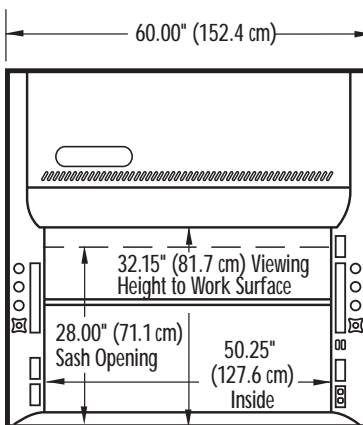

6 Feet

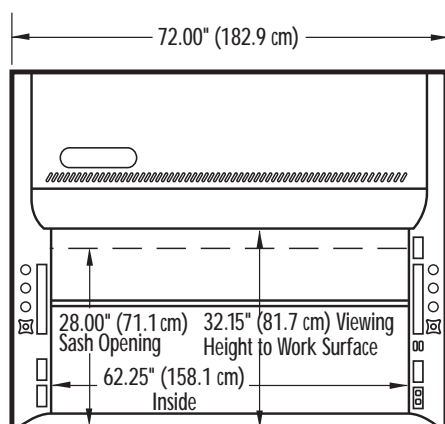

8 Feet

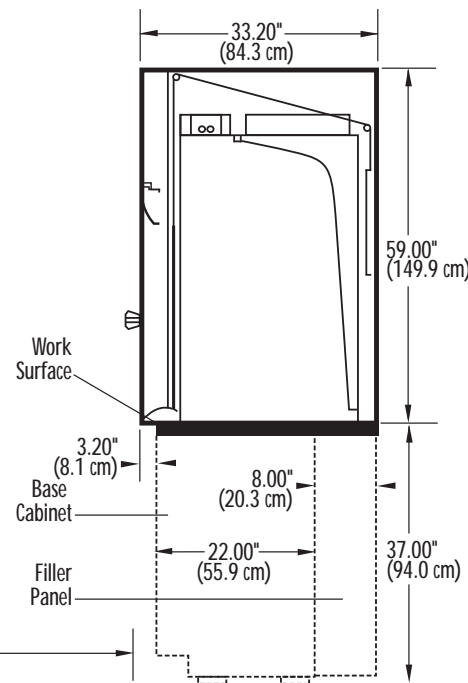
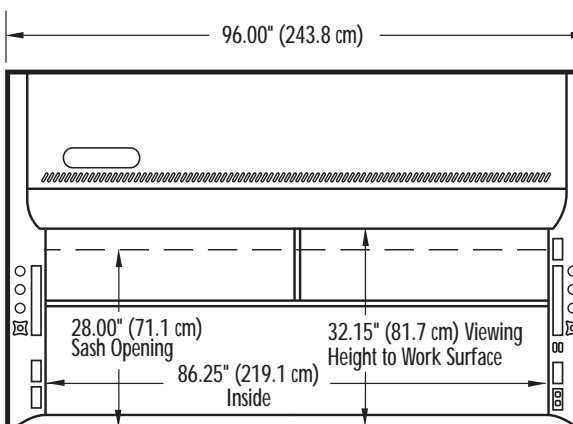

Side View / All Models

(Shown with accessory work surface and base cabinet available for all hood widths. Height can vary.)

See additional dimensional data on page 18.



Protector® Premier® Laboratory Hoods

with built-in blower



4' Protector Premier Laboratory Hood 4880300 is shown with SpillStopper Work Surface 9847100 and Protector Solvent Storage Cabinet 9902000. Ductwork, work surface and base cabinet must be ordered separately.

Explosion-proof models feature:

- Explosion-proof blower and incandescent light fixture (bulb not included).
- **Furnished without switches, electrical receptacle and wiring as these must conform to varying local codes.**

Fixtured models feature:

- Two pre-plumbed service fixtures with forged brass valves, lower right side with brass tubing for gas and lower left side with copper tubing for cold water. Components for converting either or both fixtures to air and vacuum are provided. **Inlet tubing is not provided.**
- One pre-wired 115 volt, 20 amp electrical duplex receptacle on lower right side (115 volt models).

All models require (not included):

- **Ductwork.** See back pocket.
- **Work Surface.** See pages 100-104.
- **Base Cabinet or Stand.** See pages 106-116.

Optional accessories for on-site installation include:

- **Service Fixture Kits.** See page 117.
- **Electrical Duplex Kits.** See page 118.
- **Guardian Airflow Monitor Kits.** See page 118.
- **Ceiling Enclosure and Rear Finish Panel Kits.** See pages 119-120.
- **Distillation Grid Kits.** See page 120.
- **Auxiliary-Air Kits.** See page 120.
- **Sash Stop Kits.** See page 121.

All models feature:

- Built-in belt-driven, corrosion-resistant exhaust blower with adjustable sheave, molded thermoplastic housing and non-sparking, coated aluminum impeller.
- By-pass airflow design.
- Ergonomic air foil with aerodynamic Clean-Sweep* airflow openings.
- Glacier white, dry powder epoxy-coated steel exterior.
- One-piece molded fiberglass liner and pre-set baffle(s) with flame spread less than 25 per ASTM E-84.
- 3/16" thick tempered safety glass vertical-rising sash with epoxy-coated sash handle. Sash does not extend above the hood when fully open.
- Removable front and side panels and front access panels for access to plumbing and electrical wiring.
- 10.81" ID exhaust connection (4' models); 12.81" ID exhaust connection (5' and 6' models).

All models conform to the following regulations and standards:

- SEFA 1-2006
- NFPA 45-2004
- ASTM E84-09C
- ASHRAE 110-95
- ANSI Z9.5-2003
- UL 3101-1/61010-1
- CAN/CSA C22.2 No. 1010.1
- UL 1805
- CE Conformity Marking (230 volt models)

Standard models feature:

- Pre-wired T8 fluorescent lighting, light and blower switches.

Exclusive Feature

Built-In Blower Maximum External Static Pressure @ 100 fpm and with Sash Full Open (28")

Hood Width	CFM	S.P.	Nominal Ductwork Diameter	Equivalent Resistance**
4 Feet	730	0.17"	10"	75
5 Feet	960	0.12"	12"	75
6 Feet	1180	0.17"	12"	70

Contact Labconco or visit www.labconco.com for blower curve information.

* U.S. Patent No. 6,461,233

** Equivalent resistance in feet of straight duct

Heights of switches, electrical receptacle and service fixtures meet requirements of ADA.



Ordering Information

Protector® Premier® Laboratory Hoods with built-in blower

Nominal Width	Catalog Number	Built-In Blower	Electrical Requirements	Exhaust Collar (ID)	EP Incandescent Light Fixture*	Fluorescent Lamps	Service Fixtures	Electrical Duplex	Shipping Weight lbs./kg
4 Feet	4880000	1/3 HP, Std.	115 volts, 60 Hz	10.81" (27.5 cm)	—	2 ea. 25 watt	None	None	365/166
	4880200	1/3 HP, EP	115 volts, 60 Hz	10.81" (27.5 cm)	1 ea.	—	None	None	375/170
	4880300	1/3 HP, Std.	115 volts, 60 Hz	10.81" (27.5 cm)	—	2 ea. 25 watt	2	1	375/170
	4871300**	1/2 HP, Std.	230 volts, 50 Hz	10.81" (27.5 cm)	—	2 ea. 25 watt	None	None	370/168
	4871400**	1/2 HP, Std.	230 volts, 50 Hz	10.81" (27.5 cm)	—	2 ea. 25 watt	2	None	380/172
5 Feet	6080000	1/2 HP, Std.	115 volts, 60 Hz	12.81" (32.5 cm)	—	2 ea. 32 watt	None	None	450/204
	6080200	1/2 HP, EP	115 volts, 60 Hz	12.81" (32.5 cm)	1 ea.	—	None	None	460/209
	6080300	1/2 HP, Std.	115 volts, 60 Hz	12.81" (32.5 cm)	—	2 ea. 32 watt	2	1	460/209
	6071300**	1/2 HP, Std.	230 volts, 50 Hz	12.81" (32.5 cm)	—	2 ea. 32 watt	None	None	455/206
	6071400**	1/2 HP, Std.	230 volts, 50 Hz	12.81" (32.5 cm)	—	2 ea. 32 watt	2	None	455/211
6 Feet	7280000	1/2 HP, Std.	115 volts, 60 Hz	12.81" (32.5 cm)	—	2 ea. 32 watt	None	None	525/238
	7280200	1/2 HP, EP	115 volts, 60 Hz	12.81" (32.5 cm)	1 ea.	—	None	None	535/243
	7280300	1/2 HP, Std.	115 volts, 60 Hz	12.81" (32.5 cm)	—	2 ea. 32 watt	2	1	535/243
	7271300**	1/2 HP, Std.	230 volts, 50 Hz	12.81" (32.5 cm)	—	2 ea. 32 watt	None	None	530/240
	7271400**	1/2 HP, Std.	230 volts, 50 Hz	12.81" (32.5 cm)	—	2 ea. 32 watt	2	None	540/245

*Bulb not included **International electrical configuration EP = explosion-proof

4 Feet

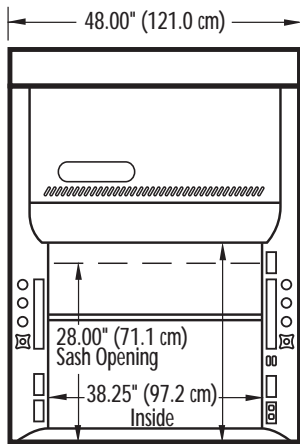

32.15" (81.7 cm) Viewing Height to Work Surface

5 Feet

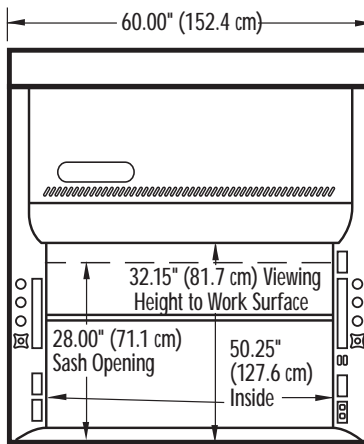

6 Feet

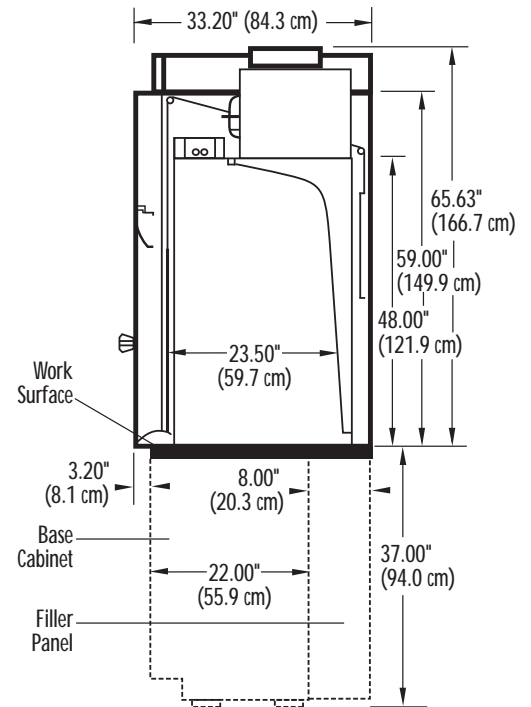
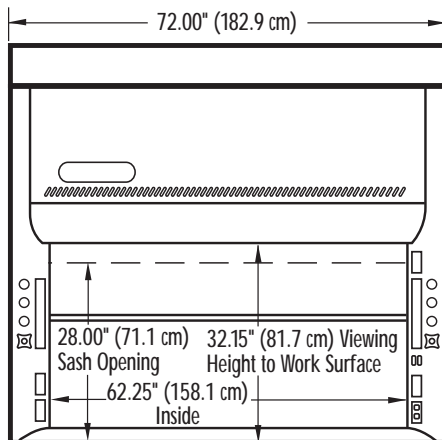

Side View / All Models

(Shown with accessory work surface and base cabinet available for all hood widths. Height can vary.)

See additional dimensional data on page 19.



Dimensional Data

4', 5', 6' and 8' Protector® Premier® Laboratory Hoods for use with remote blower

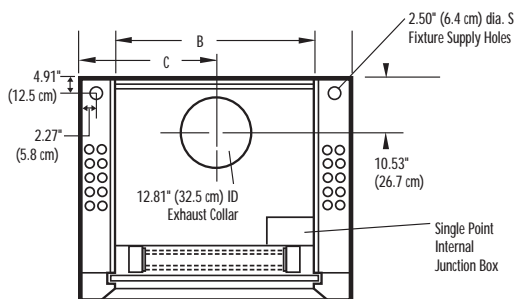

TOP

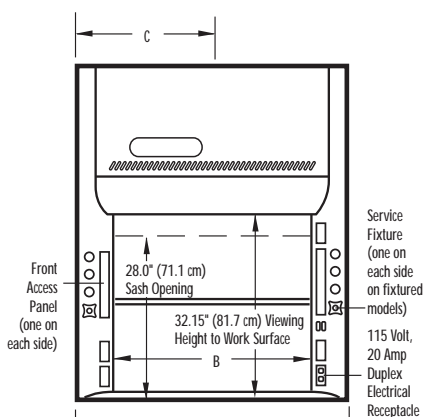

FRONT

4', 5' and 6' Hoods

	A	B	C
4' Hood	48.00" (121.9 cm)	38.25" (97.2 cm)	24.00" (61.0 cm)
5' Hood	60.00" (152.4 cm)	50.25" (127.6 cm)	30.00" (76.2 cm)
6' Hood	72.00" (182.9 cm)	62.25" (158.1 cm)	36.00" (91.4 cm)

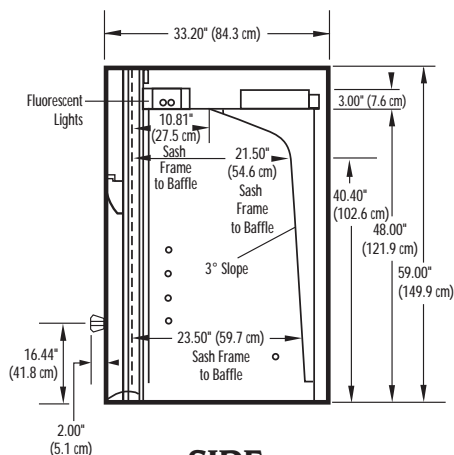

SIDE

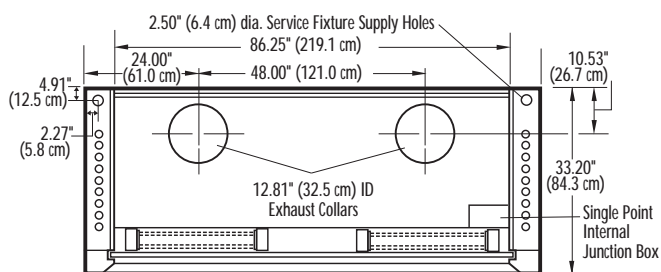

TOP

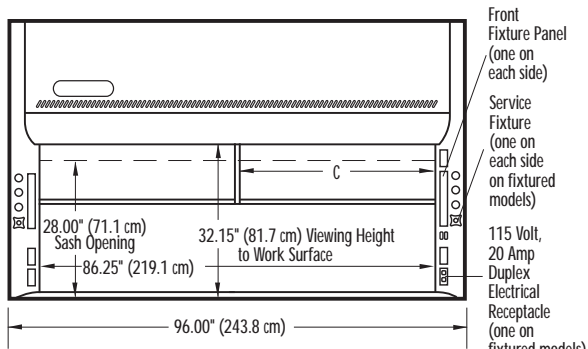

FRONT

8' Hoods

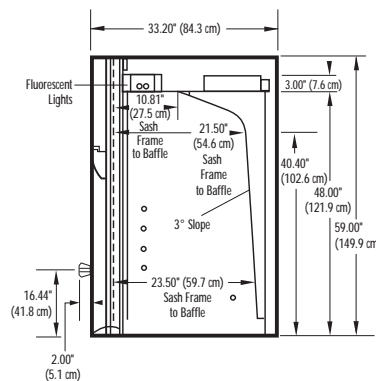

SIDE



Dimensional Data

4', 5' and 6' Protector® Premier® Laboratory Hoods with built-in blower

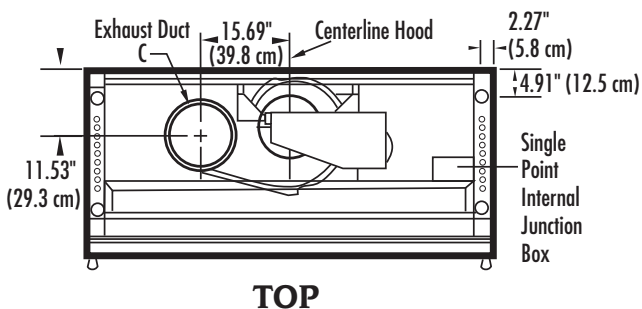

	A	B	C
4' Hood	48.00" (121.9 cm)	38.25" (97.2 cm)	10.81" ID (27.5 cm)
5' Hood	60.00" (152.4 cm)	50.25" (127.6 cm)	12.81" ID (32.5 cm)
6' Hood	72.00" (182.9 cm)	62.25" (158.1 cm)	12.81" ID (32.5 cm)

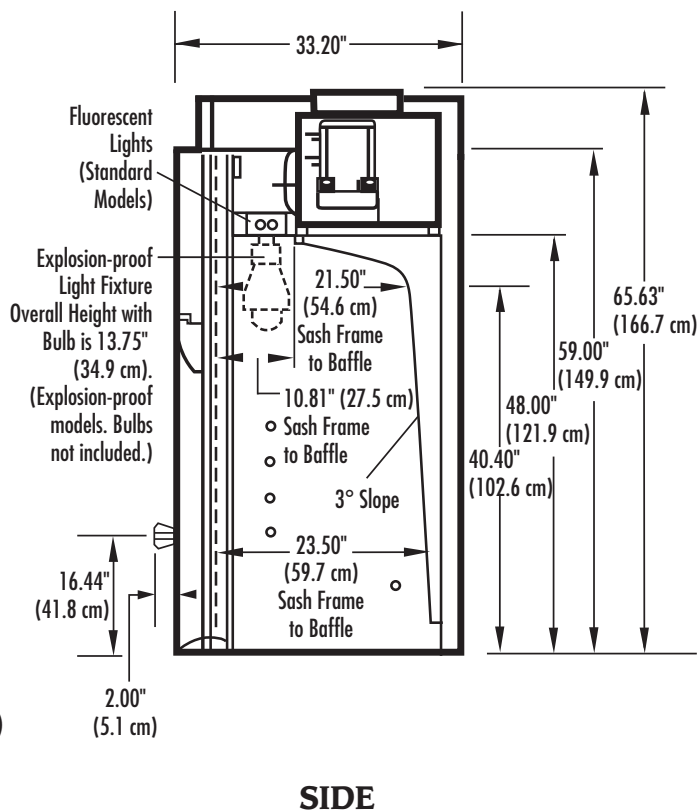
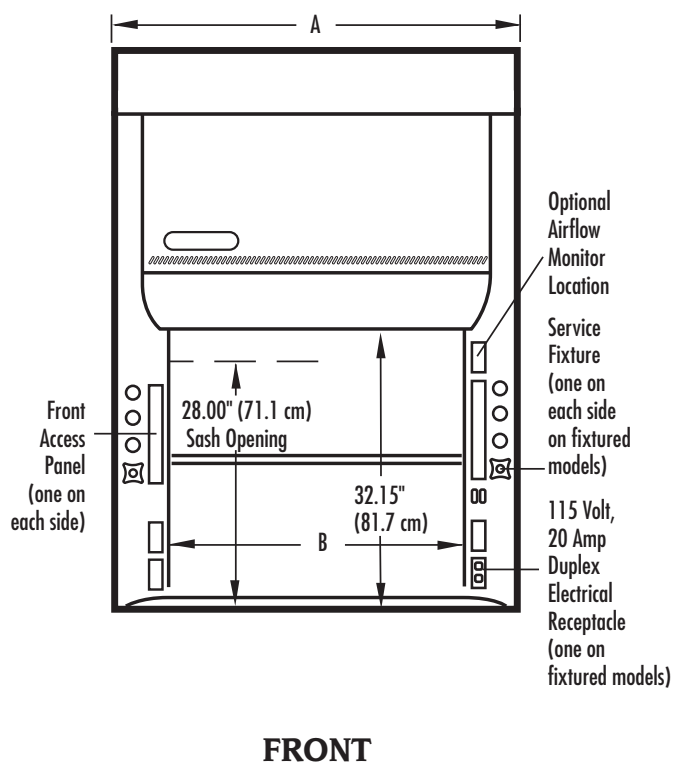

Contact Labconco at 800-821-5525 or 816-333-8811 for detailed AutoCAD drawings.



6' Protector XStream Laboratory Hood 9840600 is shown with SpillStopper Work Surface 9849800, Protector Acid Storage Cabinet 9901100 and Protector Standard Storage Cabinet 9900100.



Requires
Ductwork and
Blower



Protector® XStream® Laboratory Hoods

Patented* High Performance and Low Flow Features & Benefits

With its energy savings potential and unsurpassed containment, regardless of sash position, the patented Protector XStream is truly a high performance hood. Features, such as an upper dilution air supply, containment-enhancing sash handle, rear downflow dual baffle system and air foil, work together to decrease turbulence and enhance airflow. When operated at OSHA-approved 60 fpm

face velocity, Protector XStream Laboratory Hoods provide an excellent economic payback when compared to traditional hoods running at 80 or 100 fpm.

These panel-lined hoods are available in 4', 5', 6' and 8' widths. They are designed to be used with a remotely-located blower or building exhaust system.

Using the concepts of fluid dynamics, Labconco researchers engineered the Protector XStream Laboratory Hood with **horizontal laminar airflow to reduce the tendencies for turbulence**. The innovative and aerodynamic designs of the sash handle, air foil, upper dilution air supply and rear downflow baffle work in concert

to produce horizontal airflow patterns that significantly reduce concentrations of chemical contaminants throughout the work area, particularly near the face of the hood, the operator's breathing zone and at the work surface. Depending on sash position, tendencies for air turbulence, vortexing and "the roll" frequently observed during traditional fume hood smoke tests are virtually eliminated.

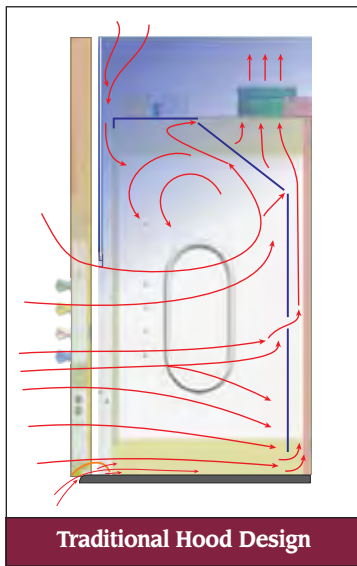

Traditional Hood Design

Smoke tests on traditional hoods show the tendency for contaminants generated in the interior to roll forward producing high concentrations of contaminants behind the sash in close proximity to the user's breathing zone.

In contrast, smoke tests on Protector XStream Hoods show contaminants removed in a single pass and a remarkable lack of turbulence. Horizontal laminar air flowing toward the baffle forces contaminants to the rear interior, away from the user. The upper dilution air supply sweeps the upper interior to eliminate stagnant pockets of air and to prevent contaminants from concentrating in the area behind the sash.

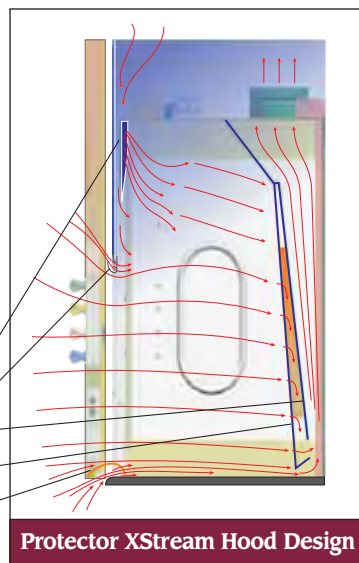

- Upper Dilution Air Supply
- Containment-Enhancing Sash Handle
- Secondary Baffle
- Primary Baffle
- Ergonomic Air Foil with Clean-Sweep Openings

Protector XStream Hood Design

Upper Dilution Air Supply

The **sash interior is constantly bathed with room air** from the dilution supply above the work area to eliminate chemical fumes along the sash plane, near the critical breathing zone. Five to ten percent of the required air volume is introduced through the dilution air supply to ensure maximum containment and greatest worker protection. **No additional blowers are required.**

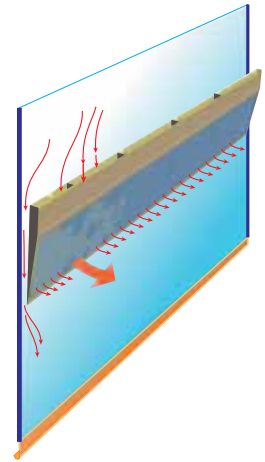

Rear Downflow Dual Baffle System

When the sash is open to the 18" working height or 28" loading height, the slots in the primary baffle **direct inflow air in non-turbulent streams** from the hood face into the baffle in a single pass. The secondary baffle, located between the primary baffle and

the back wall, counteracts the upward air streams that create roll in traditional hoods by forcing the air movement downward before exhausting. **No moving mechanical components are used.**



Smoke released inside the hood moves in a horizontal stream to the primary baffle slots.

Containment-Enhancing Sash Handle

The revolutionary sash handle design includes a perforated air passage directly atop the handle to bleed air into the hood chamber and **direct chemical fume concentrations away from the user's breathing zone**. The large radiused sash handle sweeps airflow into the hood with minimal turbulence. Its ergonomic design is comfortable to the touch and easy to grasp to raise and lower the sash.



At left: Arrows show how air enters under the sash handle and through slots directly atop the handle.

Exclusive Feature

* U.S. Patent No. 6,461,233



Protector® XStream® Laboratory Hoods

Additional Features & Benefits

Front and side panels may be easily removed for lamp replacement and access to electrical supply connections.

Fluorescent lighting illuminates the interior. The high efficiency, instant start, T8 fluorescent lights are located outside the hood interior for corrosion-resistance and easy replacement. Contact Labconco for ordering information on explosion-proof lighting.

Durable and attractive exterior is glacier white, dry powder epoxy-coated steel.

Large 28" sash opening offers superior viewing. When fully open, the sash does not extend above the hood.

Vertical-rising tempered safety glass sash is anti-racking for smooth operation.

Chemical-resistant, fiberglass-reinforced composite panel liner surpasses all national codes for flame spread and has a bright white surface for excellent light reflectivity.

Service access panels allow accessibility to plumbing from the front and inside of the hood.

Color-coded service fixtures for gas, air, water, vacuum and other services have remote controls for use regardless of the sash position. Two service fixtures are pre-plumbed on fixtured models. Each hood is factory prepared for up to eight service fixtures (four on each side).

By-pass airflow design ensures stable face velocities that meet or exceed established standards.

ETL-listed. Hoods carry the ETL mark signifying that they are certified to UL 3101-1/61010-1, UL 1805 and CAN/CSA C22.2 No. 1010.1.

Performance tested to ASHRAE 110-1995.

CE mark. All 230 volt, 50 Hz models conform to the CE (European Community) requirements for electrical safety and electromagnetic compatibility.

Pre-wired electrical components. Fluorescent lights and switches are factory-wired to the hood's single point junction box. One electrical duplex receptacle is factory-wired on 115 volt, 60 Hz fixtured models. Each hood is factory-prepared for up to four electrical duplexes and an airflow monitor.

Ergonomic air foil allows air to sweep the work surface for maximum containment. Clean-Sweep* airflow openings pull inflow air from under the air foil so that clean air continually flows over the air foil creating a constant barrier of protection from contaminants.

Sash stop located at 18" working height maximizes energy conservation by preventing the sash from being raised further unless manually released.

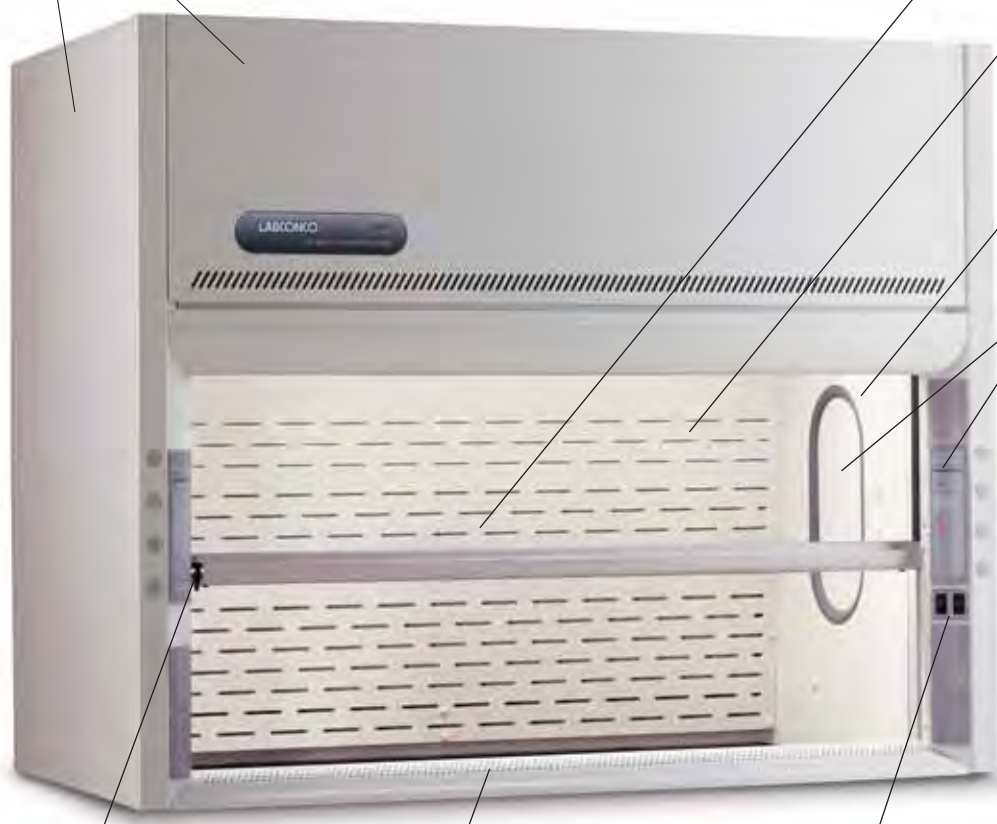

 Exclusive Feature

*U.S. Patent No. 6,461,233



Protector® XStream® Laboratory Hoods



Requires Ductwork and Blower



All models conform to the following regulations and standards:

- SEFA 1-2006
- NFPA 45-2004
- ASTM E84-09C
- ASHRAE 110-95
- ANSI Z9.5-2003
- UL 3101-1/61010-1
- CAN/CSA C22.2 No. 1010.1
- UL 1805
- CE Conformity Marking (230 volt models)

Fixtured models feature:

- Two pre-plumbed service fixtures with forged brass valves, lower right side with brass tubing for gas and lower left side with copper tubing for cold water. Components for converting either or both fixtures to air and vacuum are provided. **Inlet tubing is not provided.**
- One pre-wired 115 volt, 20 amp electrical duplex receptacle on lower right side.

All models require (not included):

- **Remote Blower.** See back pocket.
- **Ductwork.** See back pocket.
- **Work Surface.** See pages 100-104.
- **Base Cabinet or Stand.** See pages 106-116.

Optional accessories for on-site installation include:

- **Service Fixture Kits.** See page 117.
- **Electrical Duplex Kits.** See page 118.
- **Guardian Airflow Monitor Kits.** See page 118.
- **Ceiling Enclosure and Rear Finish Panel Kits.** See pages 119-120.
- **Distillation Grid Kits.** See page 120.
- **Sash Stop Kits.** See page 121.
- **Snuffer Fire Extinguishers.** See page 121.

All models feature:

- By-pass airflow design.
- Ergonomic air foil with aerodynamic Clean-Sweep* airflow openings.
- Upper Dilution Air Supply.*
 - Glacier white, dry powder epoxy-coated steel exterior.
- Chemical-resistant, fiberglass-reinforced, composite panel liner and pre-set Rear Downflow Dual Baffle System* with flame spread less than 25 per ASTM E-84.
- 3/16" thick tempered safety glass vertical-rising sash with epoxy-coated aluminum sash handle with large radius and perforations.*

- Removable front and side panels and front and interior service access panels for access to plumbing and electrical wiring.
- Pre-wired T8 fluorescent lighting, ADA-compliant light and blower switches for 115 volt, 60 Hz operation.
- Sash stop located at 18" sash opening position.
- Epoxy-coated stainless steel, 12.81" ID exhaust connection(s).

Contact Labconco at **800-821-5525** or **816-333-8811** for ordering information on explosion-proof lighting and other sash configurations and for blower sizing assistance.

* U.S. Patent No. 6,461,233

 Heights of switches, electrical receptacle and service fixtures meet requirements of ADA.

 Exclusive Feature



Ordering Information

Protector® XStream® Laboratory Hoods

ASHRAE 110-95 tests show less than 0.05 ppm leak rate when tested at 4.0 lpm; at OSHA-recognized 60, 80, and 100 fpm face velocity and sash positions of 18" and 28". To ensure performance at 60 fpm, Labconco engineers challenged the Protector XStream Hood under

adverse conditions such as 30-75 fpm cross drafts, interior obstructions and average face velocities as low as 40 fpm. Contact Labconco for a technical paper with complete ASHRAE test data or visit our airflow test facility for hands-on testing.

Total Exhaust CFM and Static Pressure @ 18" Sash Opening (60% open)

Nominal Width	100 fpm	s.p.	80 fpm	s.p.	60 fpm	s.p.	CFM Savings at 60 fpm vs. 100 fpm	Total Average Annual Dollar Savings at 60 fpm vs. 100 fpm*
4 feet	470	0.11"	380	0.07"	280	0.04"	190	\$1330
5 feet	610	0.13"	490	0.08"	370	0.05"	240	\$1680
6 feet	750	0.15"	600	0.10"	450	0.06"	300	\$2100
8 feet	1060	0.12"	850	0.08"	640	0.04"	420	\$2940

Total Exhaust CFM and Static Pressure @ 28" Sash Opening (100% open)

Nominal Width	100 fpm	s.p.	80 fpm	s.p.	60 fpm	s.p.	CFM Savings at 60 fpm vs. 100 fpm	Total Average Annual Dollar Savings at 60 fpm vs. 100 fpm*
4 feet	730	0.25"	590	0.13"	440	0.08"	290	\$2030
5 feet	960	0.30"	770	0.19"	580	0.11"	380	\$2660
6 feet	1180	0.36"	940	0.23"	710	0.13"	470	\$3290
8 feet	1660	0.28"	1330	0.18"	1000	0.10"	660	\$4620

*Based on average annual dollars per CFM usage of \$7.00; fume hood operating 24 hours a day and 5 days per week (6240 hours per year). Average annual dollars per CFM usage can range from \$5.00 - \$12.00 depending on geographic location.

Catalog Number	Nominal Width	Electrical Requirements	Exterior Depth	Interior Working Depth	Fluorescent Lamps	Service Fixtures	Electrical Duplex	Exhaust Collar(s)	Shipping Wt. lbs./kg
9840400	4 feet	115 volts, 60 Hz	39.20"	27.3"	(2) 25 watt	None	None	12.81" ID	440/200
9840401	4 feet	115 volts, 60 Hz	39.20"	27.3"	(2) 25 watt	2	1	12.81" ID	450/204
9840402**	4 feet	230 volts, 50 Hz	39.20"	27.3"	(2) 25 watt	None	None	12.81" ID	440/200
9840403**	4 feet	230 volts, 50 Hz	39.20"	27.3"	(2) 25 watt	2	None	12.81" ID	450/204
9840500	5 feet	115 volts, 60 Hz	39.20"	27.3"	(2) 32 watt	None	None	12.81" ID	525/238
9840501	5 feet	115 volts, 60 Hz	39.20"	27.3"	(2) 32 watt	2	1	12.81" ID	525/243
9840502**	5 feet	230 volts, 50 Hz	39.20"	27.3"	(2) 32 watt	None	None	12.81" ID	525/238
9840503**	5 feet	230 volts, 50 Hz	39.20"	27.3"	(2) 32 watt	2	None	12.81" ID	535/243
9840600	6 feet	115 volts, 60 Hz	39.20"	27.3"	(2) 32 watt	None	None	12.81" ID	600/272
9840601	6 feet	115 volts, 60 Hz	39.20"	27.3"	(2) 32 watt	2	1	12.81" ID	610/277
9840602**	6 feet	230 volts, 50 Hz	39.20"	27.3"	(2) 32 watt	None	None	12.81" ID	600/272
9840603**	6 feet	230 volts, 50 Hz	39.20"	27.3"	(2) 32 watt	2	None	12.81" ID	610/277
9840800	8 feet	115 volts, 60 Hz	39.20"	27.3"	(4) 25 watt	None	None	(2) 12.81" ID	770/349
9840801	8 feet	115 volts, 60 Hz	39.20"	27.3"	(4) 25 watt	2	1	(2) 12.81" ID	780/354
9840802**	8 feet	230 volts, 50 Hz	39.20"	27.3"	(4) 25 watt	None	None	(2) 12.81" ID	770/349
9840803**	8 feet	230 volts, 50 Hz	39.20"	27.3"	(4) 25 watt	2	None	(2) 12.81" ID	780/354

**International electrical configuration

4 Feet
98404 Series

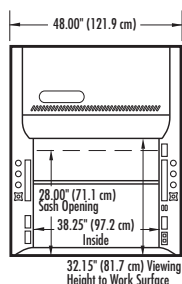

5 Feet
98405 Series

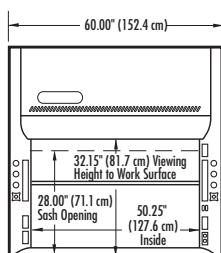

6 Feet
98406 Series

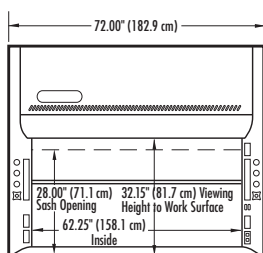

8 Feet
98408 Series

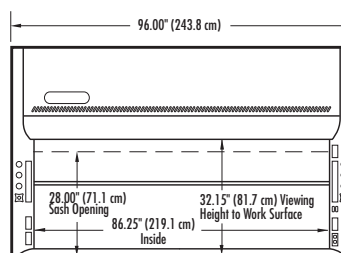

Side View /
All Models

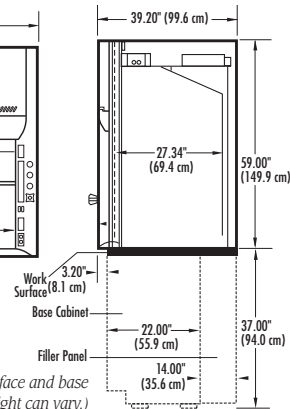

(Side view shown with accessory work surface and base cabinet available for all hood widths. Height can vary.)



Dimensional Data

Protector® XStream® Laboratory Hoods

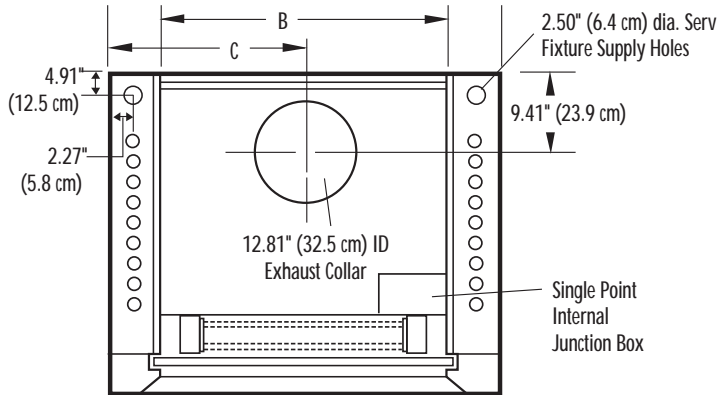

TOP 4', 5', 6'

	A	B	C
4' Hood	48.00" (121.9 cm)	38.25" (97.2 cm)	24.00" (61.0 cm)
5' Hood	60.00" (152.4 cm)	50.25" (127.6 cm)	30.00" (76.2 cm)
6' Hood	72.00" (182.9 cm)	62.25" (158.1 cm)	36.00" (91.4 cm)
8' Hood	96.00" (243.8 cm)	86.25" (219.1 cm)	24.00" (61.0 cm)

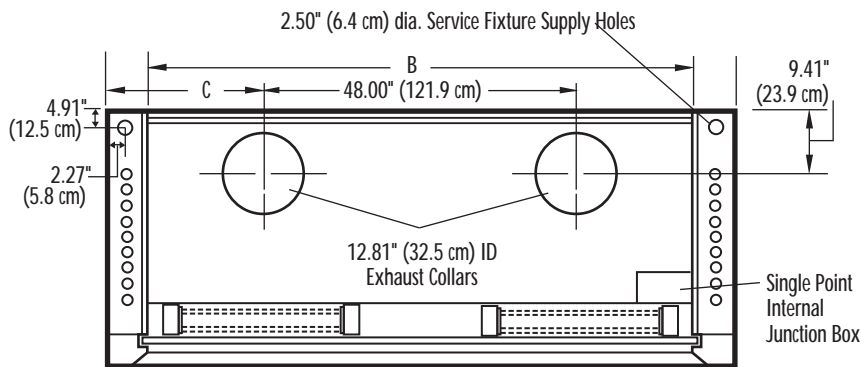

TOP 8'

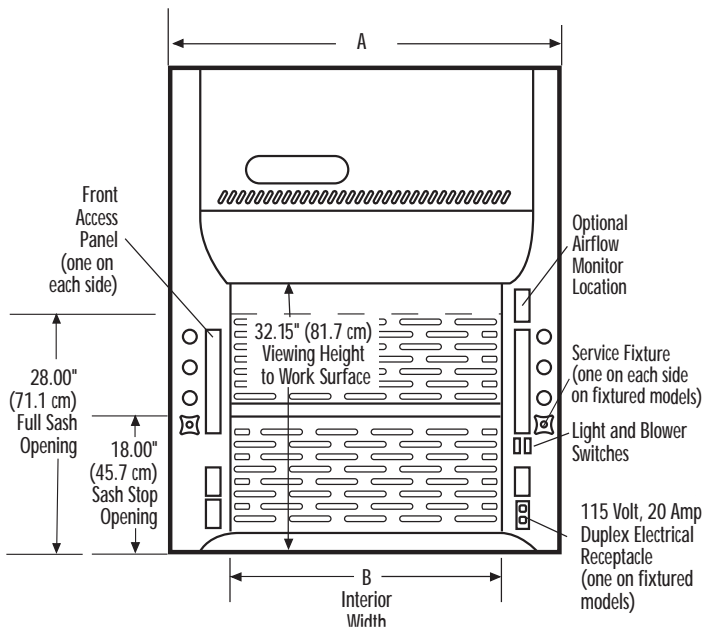

FRONT

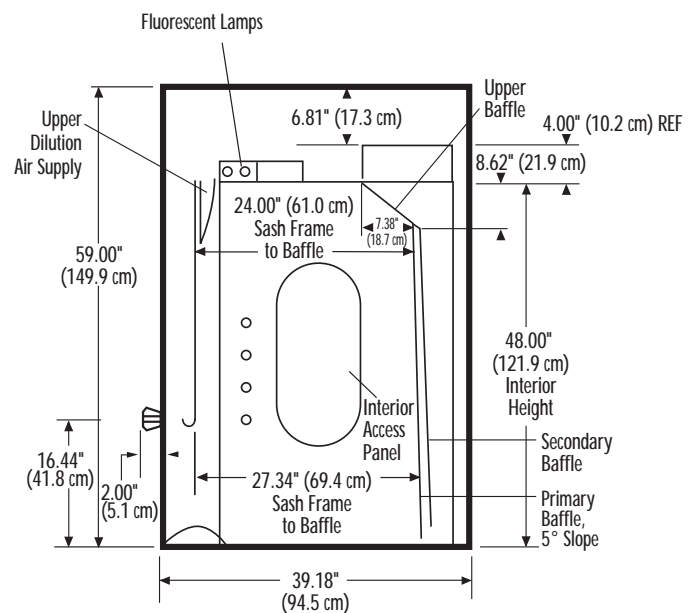

SIDE



8' Protector XL Benchtop Laboratory Hood 9700103 is shown with SpillStopper Work Surface 9848800, Protector Acid Storage Cabinet 9901000 and Protector Solvent Storage Cabinet 9902000.



Requires
Ductwork and
Blower



Protector® XL™ Benchtop Laboratory Hoods

Features & Benefits

Protector XL Benchtop Laboratory Hoods have chemical-resistant panel liners that offer superior design flexibility. They are supplied

in widths from 4 to 16 feet and three depths to meet a variety of installation and application requirements.

Front and side panels may be easily removed for lamp replacement and access to electrical supply connections.

ETL-listed. Hoods carry the ETL mark signifying that they are certified to UL Standard 3101-1/61010-1, UL 1805 and CAN/CSA C22.2 No. 1010.1.

Large sash openings offer superior viewing. Benchtop hoods feature 28" opening heights and 32.15" viewing heights.

Vertical-rising tempered safety glass sash is anti-racking for smooth operation. When fully open, the sash does not extend above the hood.

Interior working dimensions are offered in standard and larger depths. Working depths include 24", 30", and 36".

Fluorescent lighting illuminates the interior. The high-efficiency, instant start, T8 fluorescent lights are located outside the hood interior for corrosion-resistance and easy replacement. Contact Labconco for ordering information on explosion-proof lighting.

Service access panels allow easy accessibility to plumbing from the front and inside of the hood.

Chemical-resistant, fiberglass-reinforced composite panel liner surpasses all national codes for flame spread and has a bright white surface for excellent light reflectivity.

Pre-wired electrical components. Fluorescent lights and switches are factory-wired to the hood's single point junction box. One electrical duplex receptacle is factory-wired on fixtured models. Each hood is factory-prepared for up to four electrical duplexes and an airflow monitor.

Durable and attractive exterior is glacier white, dry powder epoxy-coated steel.

By-pass airflow design ensures relatively stable face velocities. Contact Labconco for ordering information on by-pass blocks.

Performance tested to ASHRAE 110-1995.



Color-coded service fixtures for gas, air, water, vacuum and other services have remote controls for use regardless of the sash position. Two service fixtures are pre-plumbed on fixtured models. Each hood is factory prepared for up to eight service fixtures (four on each side).

Ergonomic air foil allows air to sweep the work surface for maximum containment. Benchtop models feature patented* Clean-Sweep™ airflow openings that pull inflow air from under the air foil so that clean air continually flows over the air foil creating a constant barrier of protection from contaminants.

Pre-set baffle provides a uniform face velocity pattern across the sash opening of the hood. Contact Labconco for ordering information on adjustable baffles.



Exclusive Feature

*U.S. Patent No. 6,461,233



Protector® XL™ Benchtop Laboratory Hoods



Requires Ductwork and Blower



8' Protector XL Benchtop Laboratory Hood 9700103 is shown with SpillStopper Work Surface 9848800, Protector Acid Storage Cabinet 9901000 and Protector Solvent Storage Cabinet 9902000. Blower, ductwork, work surface and base cabinets must be ordered separately.

All models require (not included):

- **Remote Blower.** See back pocket.
- **Ductwork.** See back pocket.
- **Work Surface.** See page 100-104.
- **Base Cabinet or Stand.** See pages 106-116.

Optional accessories for on-site installation include:

- **Service Fixture Kits.** See page 117.
- **Electrical Duplex Kits.** See page 118.
- **Guardian Airflow Monitor Kits.** See page 118.
- **Ceiling Enclosure and Rear Finish Panel Kits.** See pages 119-120.
- **Distillation Grid Kits.** See page 120.
- **Auxiliary-Air Kits.** See page 120.
- **Sash Stop Kits.** See page 121.
- **Snuffer Fire Extinguishers.** See page 121.

Contact Labconco at **800-821-5525** or **816-333-8811** for ordering information on adjustable baffles, explosion-proof lighting, tissue screens and other sash configurations and for blower sizing assistance.

All models feature:

- By-pass airflow design.
- Ergonomic air foil with aerodynamic Clean-Sweep* airflow openings.
- Glacier white, dry powder epoxy-coated steel exterior.
- Chemical-resistant molded composite panel liner and pre-set baffle(s) with flame spread less than 25 per ASTM E-84.
- 3/16" thick tempered safety glass vertical-rising sash(es) with epoxy-coated aluminum sash handle(s). Sash does not extend above the hood when fully open.
- Removable front and side panels and front and interior service access panels for access to plumbing and electrical wiring.
- Pre-wired T8 fluorescent lighting, light and blower switches for 115 volt, 60 Hz operation.
- Epoxy-coated stainless steel, 12.81" ID exhaust connection(s).

All models conform to the following regulations and standards:

- SEFA 1-2006
- NFPA 45-2004
- ASTM E84-09C
- ASHRAE 110-95
- ANSI Z9.5-2003
- UL 3101-1/61010-1
- CAN/CSA C22.2 No. 1010.1
- UL 1805

Fixed models feature:

- Two pre-plumbed service fixtures with forged brass valves, lower right side with brass tubing for gas and lower left side with copper tubing for cold water. Components for converting either or both fixtures to air and vacuum are provided. **Inlet tubing is not provided.**
- One pre-wired 115 volt, 20 amp electrical duplex receptacle on lower right side.

With Sash Full Open (28")

Nominal Width	Total Exhaust CFM and Static Pressure			
	100 fpm	S.P.	80 fpm	S.P.
4 Feet	730	0.16"	590	0.11"
5 Feet	960	0.24"	770	0.15"
6 Feet	1180	0.28"	940	0.18"
8 Feet	1660	0.19"	1330	0.12"
10 Feet	2130	0.28"	1700	0.18"
12 Feet	2600	0.39"	2080	0.25"
16 Feet	3550	0.23"	2840	0.15"

With Sash 60% Open (18")**

Nominal Width	Total Exhaust CFM and Static Pressure					
	100 fpm	S.P.	80 fpm	S.P.	60 fpm	S.P.
4 Feet	470	0.07"	380	0.05"	280	0.03"
5 Feet	610	0.11"	490	0.08"	370	0.04"
6 Feet	750	0.14"	600	0.09"	450	0.05"
8 Feet	1060	0.08"	850	0.06"	640	0.03"
10 Feet	1370	0.12"	1100	0.08"	820	0.05"
12 Feet	1670	0.16"	1340	0.11"	1000	0.06"
16 Feet	2290	0.10"	1830	0.07"	1380	0.04"

Exclusive Feature

Heights of switches, electrical receptacle and service fixtures meet requirements of ADA.

*U.S. Patent No. 6,461,233

**Sash stop required



Ordering Information

4', 5' and 6' Protector® XL™ Benchtop Laboratory Hoods

Nominal Width	Catalog Number	Exterior Depth (A) inches/cm	Interior Depth (B) inches/cm	12.81" (32.5 cm) ID Exhaust Collar	Sash	Fluorescent Lamps	Service Fixtures	Electrical Duplex	Shipping Weight lbs./kg
4 Feet	9750400	39.20/99.6	30.00/76.2	1	1	2 ea. 25 watt	None	None	415/188
	9750401	39.20/99.6	30.00/76.2	1	1	2 ea. 25 watt	2	1	425/193
	9750402	45.20/114.8	36.00/91.4	1	1	2 ea. 25 watt	None	None	460/209
	9750403	45.20/114.8	36.00/91.4	1	1	2 ea. 25 watt	2	1	470/213
	9750404	33.20/84.3	24.00/61.0	1	1	2 ea. 25 watt	None	None	375/170
	9750405	33.20/84.3	24.00/61.0	1	1	2 ea. 25 watt	2	1	380/172
5 Feet	9750500	39.20/99.6	30.00/76.2	1	1	2 ea. 32 watt	None	None	490/222
	9750501	39.20/99.6	30.00/76.2	1	1	2 ea. 32 watt	2	1	500/227
	9750502	45.20/114.8	36.00/91.4	1	1	2 ea. 32 watt	None	None	535/243
	9750503	45.20/114.8	36.00/91.4	1	1	2 ea. 32 watt	2	1	545/247
	9750504	33.20/84.3	24.00/61.0	1	1	2 ea. 32 watt	None	None	450/204
	9750505	33.20/84.3	24.00/61.0	1	1	2 ea. 32 watt	2	1	460/209
6 Feet	9750600	39.20/99.6	30.00/76.2	1	1	2 ea. 32 watt	None	None	565/256
	9750601	39.20/99.6	30.00/76.2	1	1	2 ea. 32 watt	2	1	575/261
	9750602	45.20/114.8	36.00/91.4	1	1	2 ea. 32 watt	None	None	610/277
	9750603	45.20/114.8	36.00/91.4	1	1	2 ea. 32 watt	2	1	620/281
	9750604	33.20/84.3	24.00/61.0	1	1	2 ea. 32 watt	None	None	525/238
	9750605	33.20/84.3	24.00/61.0	1	1	2 ea. 32 watt	2	1	535/243

**4 Feet
97504 Series**

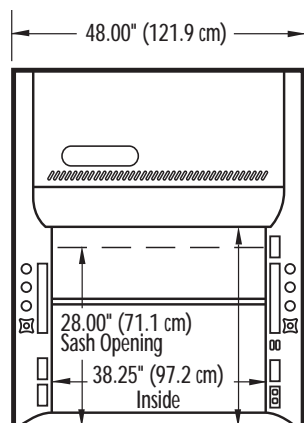

32.15" (81.7 cm) Viewing Height to Work Surface

**5 Feet
97505 Series**

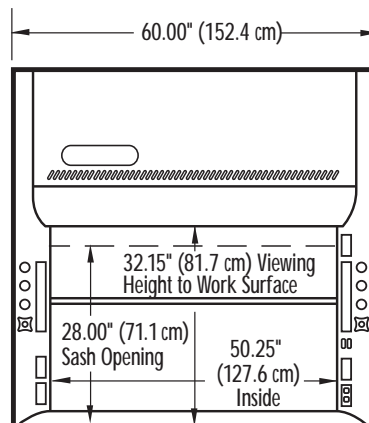

**6 Feet
97506 Series**

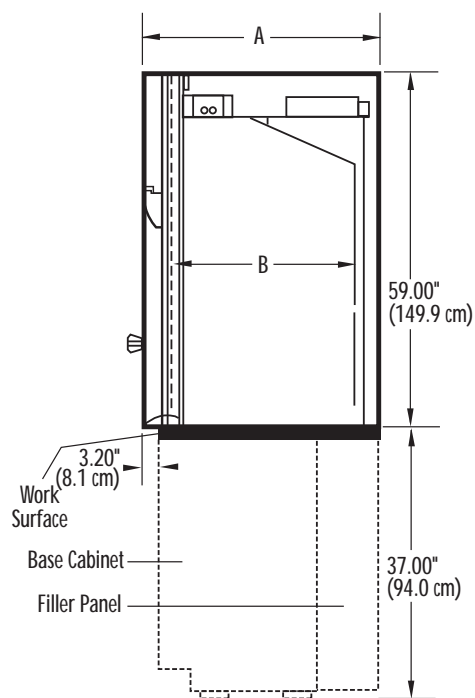
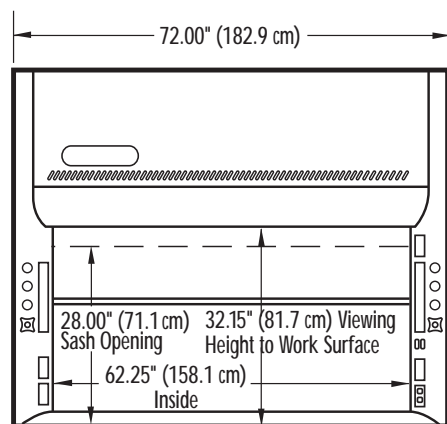

Side View / All Models

(Shown with accessory work surface and base cabinet available for all hood widths. Height can vary.)

See additional dimensional data on page 37.



Ordering Information

8' and 10' Protector[®]XL™ Benchtop Laboratory Hoods

Nominal Width	Catalog Number	Exterior Depth (A) inches/cm	Interior Depth (B) inches/cm	12.81" (32.5 cm) ID Exhaust Collars	Sashes	Fluorescent Lamps	Fixtures Fixtures	Electrical Duplex	Shipping Weight lbs./kg
8 Feet	9700100	39.20/99.6	30.00/76.2	2	2	4 ea. 25 watt	None	None	715/324
	9700101	39.20/99.6	30.00/76.2	2	2	4 ea. 25 watt	2	1	725/329
	9700102	45.20/114.8	36.00/91.4	2	2	4 ea. 25 watt	None	None	760/345
	9700103	45.20/114.8	36.00/91.4	2	2	4 ea. 25 watt	2	1	770/349
	9700104	33.20/84.3	24.00/61.0	2	2	4 ea. 25 watt	None	None	675/306
9700105	33.20/84.3	24.00/61.0	2	2	4 ea. 25 watt	2	1	685/311	
10 Feet	9700200	39.20/99.6	30.00/76.2	2	2	4 ea. 32 watt	None	None	895/403
	9700201	39.20/99.6	30.00/76.2	2	2	4 ea. 32 watt	2	1	905/411
	9700202	45.20/114.8	36.00/91.4	2	2	4 ea. 32 watt	None	None	945/529
	9700203	45.20/114.8	36.00/91.4	2	2	4 ea. 32 watt	2	1	955/433
	9700204	33.20/84.3	24.00/61.0	2	2	4 ea. 32 watt	None	None	855/388
	9700205	33.20/84.3	24.00/61.0	2	2	4 ea. 32 watt	2	1	865/392

8 Feet 97001 Series

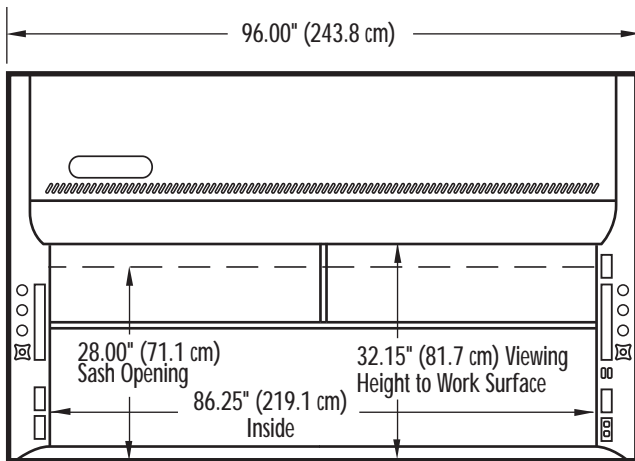

10 Feet 97002 Series

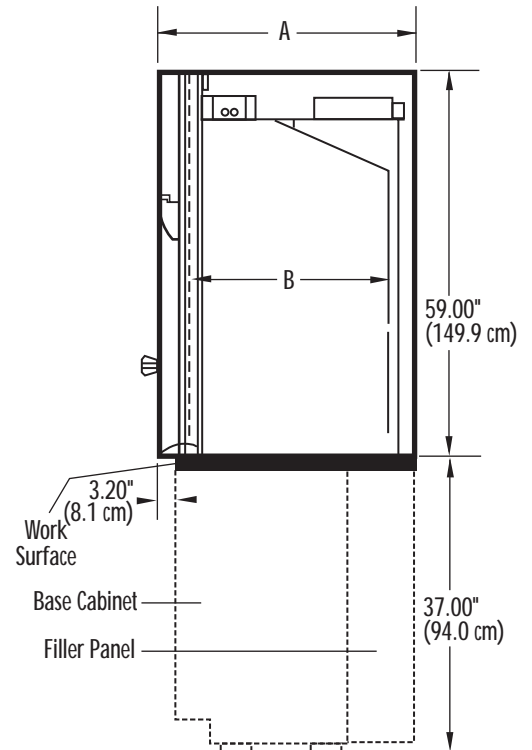
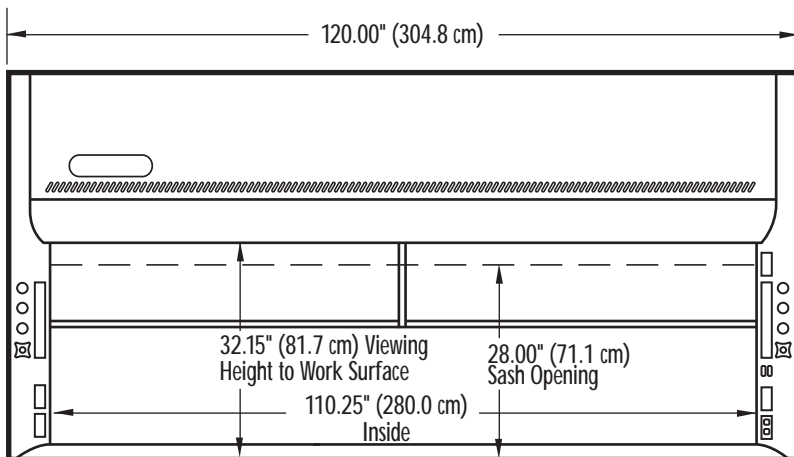

Side View / All Models

(Shown with accessory work surface and base cabinet available for all hood widths. Height can vary.)

See additional dimensional data on page 38.



Ordering Information

12' and 16' Protector[®] XL™ Benchtop Laboratory Hoods

Nominal Width	Catalog Number	Exterior Depth (A) inches/cm	Interior Depth (B) inches/cm	12.81" (32.5 cm) ID Exhaust Collars	Sashes	Fluorescent Lamps	Fixtures	Electrical Duplex	Shipping Weight lbs./kg
12 Feet	9700300	39.20/99.6	30.00/76.2	2	2	4 ea. 32 watt	None	None	1200/544
	9700301	39.20/99.6	30.00/76.2	2	2	4 ea. 32 watt	2	1	1210/549
	9700302	45.20/114.8	36.00/91.4	2	2	4 ea. 32 watt	None	None	1260/572
	9700303	45.20/114.8	36.00/91.4	2	2	4 ea. 32 watt	2	1	1270/576
	9700304	33.20/84.3	24.00/61.0	2	2	4 ea. 32 watt	None	None	1140/497
	9700305	33.20/84.3	24.00/61.0	2	2	4 ea. 32 watt	2	1	1150/522
16 Feet	9700400	39.20/99.6	30.00/76.2	4	4	8 ea. 25 watt	None	None	1600/726
	9700401	39.20/99.6	30.00/76.2	4	4	8 ea. 25 watt	2	1	1610/730
	9700402	45.20/114.8	36.00/91.4	4	4	8 ea. 25 watt	None	None	1680/762
	9700403	45.20/114.8	36.00/91.4	4	4	8 ea. 25 watt	2	1	1690/767
	9700404	33.20/84.3	24.00/61.0	4	4	8 ea. 25 watt	None	None	1520/689
	9700405	33.20/84.3	24.00/61.0	4	4	8 ea. 25 watt	2	1	1530/694

12 Feet 97003 Series

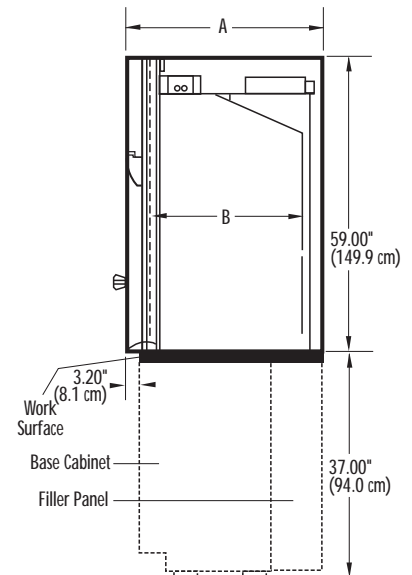
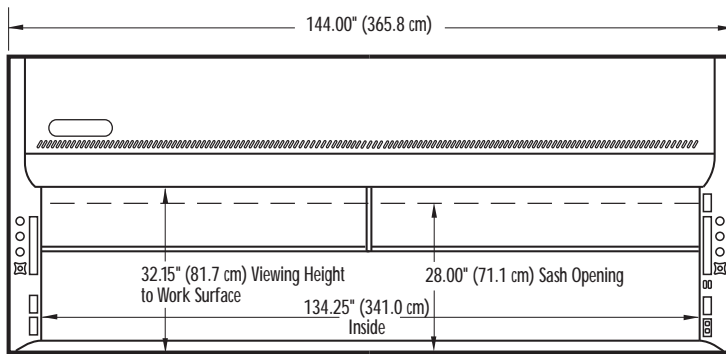

16 Feet 97004 Series

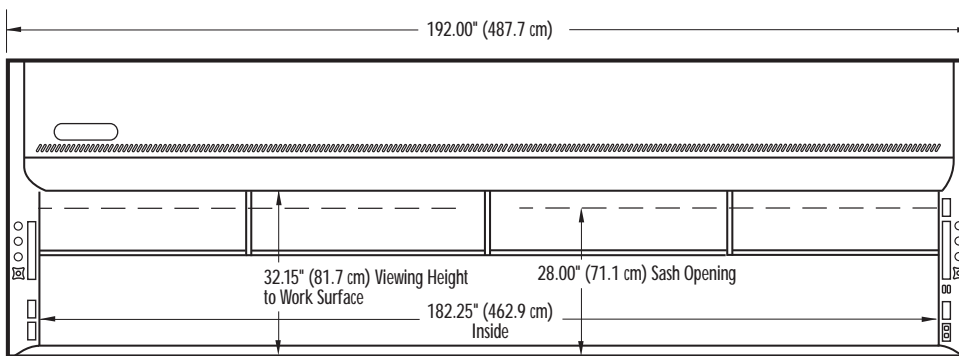

Side View/All Models
(Shown with accessory work surface and base cabinet available for all hood widths. Height can vary.)

See additional dimensional data on page 38.



*8' Protector XL Floor-Mounted Laboratory Hood 9700805.
Inset: 6' Protector XL Floor-Mounted Laboratory Hood 9860601.*



Requires
Ductwork and
Blower



Protector[®] XL™ Floor-Mounted Laboratory Hoods

Features & Benefits

Protector XL Floor-Mounted Laboratory Hoods accommodate laboratory procedures that require over-sized equipment or maximum work area. Users with applications requiring distillation racks, extraction apparatus or large drums and carboys benefit

from the increased height these hoods provide. Protector XL Floor-Mounted Laboratory Hoods are supplied in three depths and several widths up to 16 feet. Depending on the model, these hoods have vertical-rising or horizontal-sliding sashes.

Front and side panels may be easily removed for lamp replacement and access to electrical supply connections.

ETL-listed. Hoods carry the ETL mark signifying that they are certified to UL 3101-1/61010-1, UL 1805 and CAN/CSA C22.2 No. 1010.1.

Durable and attractive exterior is glacier white, dry powder epoxy-coated steel.

Tempered safety glass sashes are anti-racking for smooth operation. Hoods feature either vertical-rising or horizontal-sliding sashes depending on hood model. When fully open, vertical-rising sashes do not extend above the hood.

Adjustable baffles provide a uniform face velocity pattern across the sash opening of the hood.

Fluorescent lighting illuminates the interior. The high-efficiency, instant start, T8 fluorescent lights are located outside the hood interior for corrosion-resistance and easy replacement. Contact Labconco for ordering information on explosion-proof lighting.

Large sash openings offer superior viewing. Hoods have 68.15" viewing heights.

Pre-wired electrical components. Fluorescent lights and switches are factory-wired to the hood's single point junction box. One electrical duplex receptacle is factory-wired on fixtured models. Each hood is factory-prepared for up to four electrical duplexes and an airflow monitor.

Interior working dimensions are offered in standard and larger depths. Working depths include 30", 36" and 48".

Performance tested to ASHRAE 110-1995.

By-pass airflow design ensures relatively stable face velocities.



Color-coded service fixtures for gas, air, water, vacuum and other services have remote controls for use regardless of the sash position. Two service fixtures are pre-plumbed on fixtured models. Each hood is factory prepared for up to eight service fixtures (four on each side).

Service access panels allow easy accessibility to plumbing from the front and inside of the hood.

Chemical-resistant, fiberglass-reinforced composite panel liner surpasses all national codes for flame spread and has a bright white surface for excellent light reflectivity.





Protector® XL™ Floor-Mounted Laboratory Hoods



6' Protector XL Floor-Mounted Laboratory Hood 9860601. Blower and ductwork must be ordered separately.



Requires Ductwork and Blower



Fixtured models feature:

- Two pre-plumbed service fixtures with forged brass valves, lower right side with brass tubing for gas and lower left side with copper tubing for cold water. Components for converting either or both fixtures to air and vacuum are provided. **Inlet tubing is not provided.**
- One pre-wired 115 volt, 20 amp electrical duplex receptacle on lower right side.

All models require (not included):

- **Remote Blower.** See back pocket.
- **Ductwork.** See back pocket.

Optional accessories for on-site installation include:

- **Service Fixture Kits.** See page 117.
- **Electrical Duplex Kits.** See page 118.
- **Guardian Airflow Monitor Kits.** See page 118.
- **Ceiling Enclosure and Rear Finish Panel Kits.** See pages 119-120.
- **Snuffer Fire Extinguishers.** See page 121.

Contact Labconco at **800-821-5525** or **816-333-8811** for ordering information on explosion-proof lighting, solid epoxy floors, tissue screens and distillation grids; and for blower sizing assistance.

Heights of switches, electrical receptacle and service fixtures meet requirements of ADA.

8' Protector XL Floor-Mounted Laboratory Hood 9700805. Blower and ductwork must be ordered separately.

All models feature:

- By-pass airflow design.
- Glacier white, dry powder epoxy-coated steel exterior.
- Chemical-resistant, fiberglass-reinforced composite panel liner and adjustable upper and lower baffles with flame spread less than 25 per ASTM E-84.
- Removable front and side panels and exterior and interior service access panels for access to plumbing and electrical wiring.
- Pre-wired T8 fluorescent lighting, light and blower switches for 115 volt, 60 Hz operation.
- Shipped in multiple sections, top and bottom.
- Epoxy-coated stainless steel, 12.81" ID exhaust connection(s).

4', 5', 6' and 8' models feature:

- Two 3/16" thick tempered safety glass vertical-rising sashes framed with PVC (4', 5' and 6' models) or epoxy-coated aluminum (8' models). Sashes do not extend above the hood when fully open.

8', 10', 12' and 16' models feature:

- Four 3/16" thick tempered safety glass horizontal-sliding sashes with epoxy-coated aluminum frames and sash tracks.

All models conform to the following regulations and standards:

- SEFA 1-2006
- NFPA 45-2004
- ASTM E84-09C
- ASHRAE 110-95
- ANSI Z9.5-2003
- UL 3101-1/61010-1
- CAN/CSA C22.2 No. 1010.1
- UL 1805



Ordering Information

4', 5', 6' and 8' Protector® XL™ Floor-Mounted Laboratory Hoods with vertical-rising sashes

Nominal Width	Catalog Number	Exterior Depth (A) inches/cm	Interior Depth (B) inches/cm	12.81" (32.5 cm) ID Exhaust Collar(s)	Fluorescent Lamps	Service Fixtures	Electrical Duplex	Shipping Weight lbs./kg
4 Feet	9860401	39.20/99.6	30.00/76.2	1	2 ea. 25 watt	2	1	700/318
	9860403	45.20/114.8	36.00/91.4	1	2 ea. 25 watt	2	1	715/324
	9860405	57.20/145.3	48.00/121.9	1	2 ea. 25 watt	2	1	745/338
5 Feet	9860501	39.20/99.6	30.00/76.2	1	2 ea. 32 watt	2	1	815/370
	9860503	45.20/114.8	36.00/91.4	1	2 ea. 32 watt	2	1	830/376
	9860505	57.20/145.3	48.00/121.9	1	2 ea. 32 watt	2	1	860/390
6 Feet	9860601	39.20/99.6	30.00/76.2	1	2 ea. 32 watt	2	1	940/426
	9860603	45.20/114.8	36.00/91.4	1	2 ea. 32 watt	2	1	955/433
	9860605	57.20/145.3	48.00/121.9	1	2 ea. 32 watt	2	1	985/447
8 Feet	9700807	39.20/99.6	30.00/76.2	2	4 ea. 25 watt	2	1	1180/535
	9700809	45.20/114.8	36.00/91.4	2	4 ea. 25 watt	2	1	1195/542
	9700811	57.20/145.3	48.00/121.9	2	4 ea. 25 watt	2	1	1225/556

Nominal Width	Total Exhaust CFM and Static Pressure with sashes 50% open			
	100 fpm	S.P.	80 fpm	S.P.
4 Feet	680	0.16"	550	0.10"
5 Feet	900	0.24"	720	0.16"
6 Feet	1120	0.28"	900	0.18"
8 Feet	1560	0.19"	1250	0.12"

**4 Feet
98604 Series**

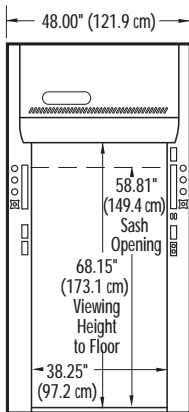

**5 Feet
98605 Series**

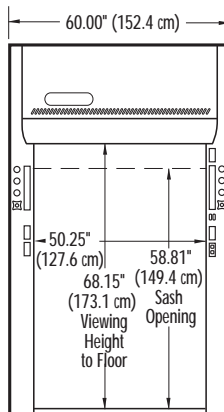

**Side View
All models**

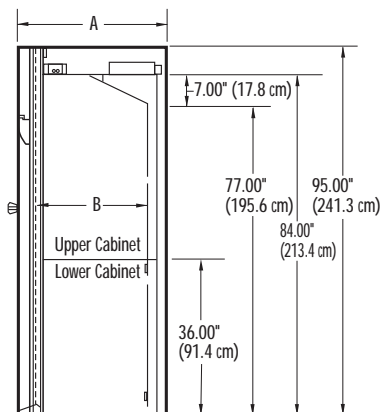

**6 Feet
98606 Series**

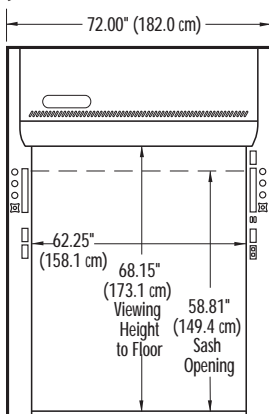

**8 Feet
97008 Series**

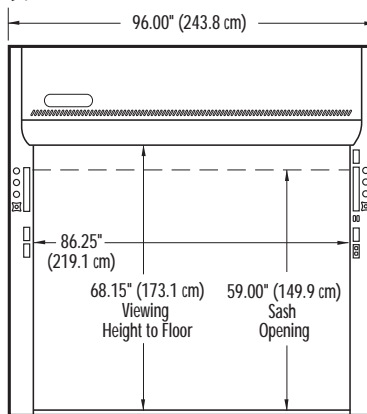

See additional dimensional data on page 39.



Ordering Information

8', 10', 12' and 16' Protector® XL™ Floor-Mounted Laboratory Hoods with horizontal-sliding sashes

Nominal Width	Catalog Number	Exterior Depth (A) inches/cm	Interior Depth (B) inches/cm	12.81" (32.5 cm) ID Exhaust Collar(s)	Fluorescent Lamps	Service Fixtures	Electrical Duplex	Shipping Weight lbs./kg
8 Feet	9700801	39.20/99.6	30.00/76.2	2	4 ea. 25 watt	2	1	1130/513
	9700803	45.20/114.8	36.00/91.4	2	4 ea. 25 watt	2	1	1145/519
	9700805	57.20/145.3	48.00/121.9	2	4 ea. 25 watt	2	1	1175/533
10 Feet	9700901	39.20/99.6	30.00/76.2	2	4 ea. 32 watt	2	1	1375/624
	9700903	45.20/114.8	36.00/91.4	2	4 ea. 32 watt	2	1	1390/630
	9700905	57.20/145.3	48.00/121.9	2	4 ea. 32 watt	2	1	1420/644
12 Feet	9701001	39.20/99.6	30.00/76.2	2	4 ea. 32 watt	2	1	1645/733
	9701003	45.20/114.8	36.00/91.4	2	4 ea. 32 watt	2	1	1660/753
	9701005	57.20/145.3	48.00/121.9	2	4 ea. 32 watt	2	1	1690/767
16 Feet	9716001	39.20/99.6	30.00/76.2	4	8 ea. 25 watt	2	1	2085/946
	9716003	45.20/114.8	36.00/91.4	4	8 ea. 25 watt	2	1	2100/953
	9716005	57.20/145.3	48.00/121.9	4	8 ea. 25 watt	2	1	2130/966

Nominal Width	Sashes Open	Total Exhaust CFM and Static Pressure			
		100 fpm	S.P.	80 fpm	S.P.
8 Feet	2	2200	0.30"	1760	0.19"
10 Feet	1	1360	0.12"	1090	0.08"
12 Feet	1	1660	0.15"	1330	0.10"
16 Feet	1	2260	0.10"	—	—

**8 Feet
97008 Series**

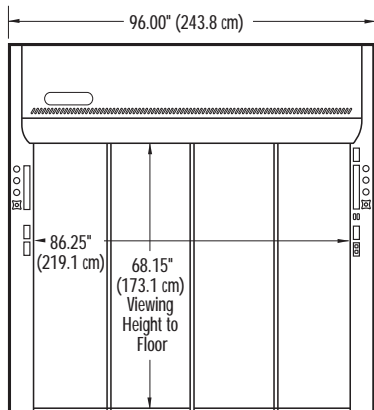

**10 Feet
97009 Series**

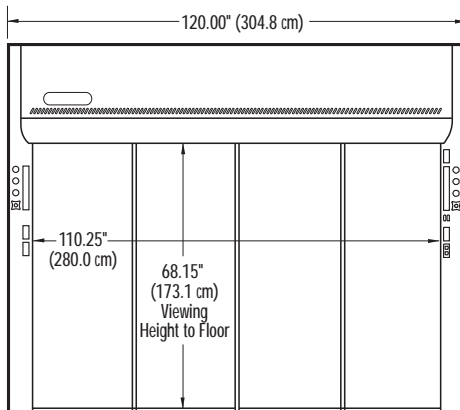

**Side View
All models**

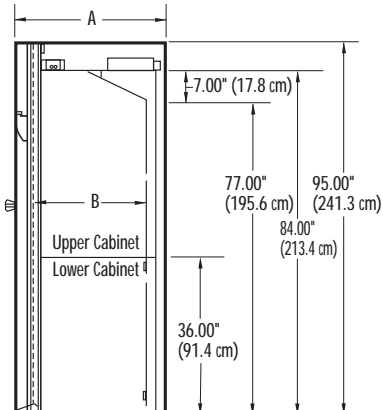

**12 Feet
97010 Series**

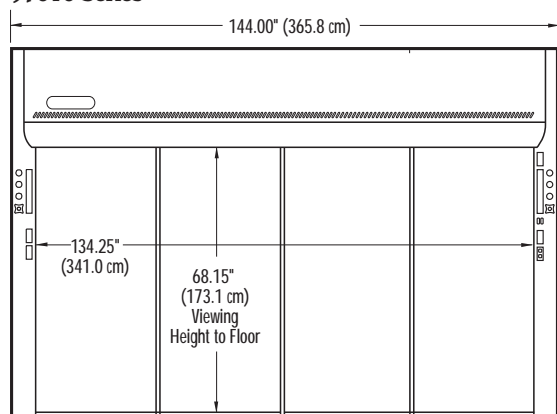

**16 Feet
97160 Series**

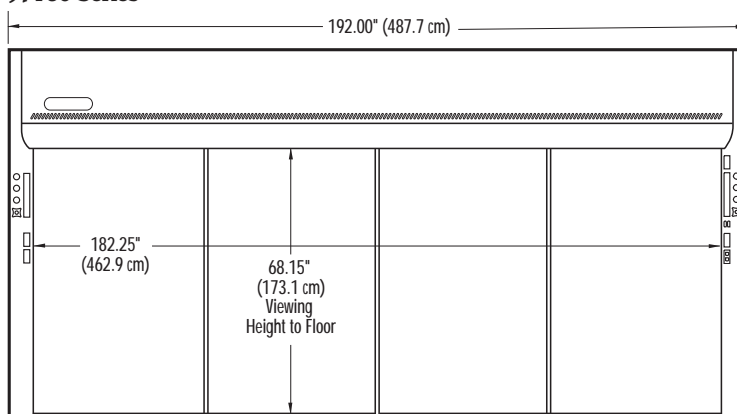

See additional dimensional data on page 40.



Dimensional Data

4', 5' and 6' Protector[®]XL™ Benchtop Laboratory Hoods

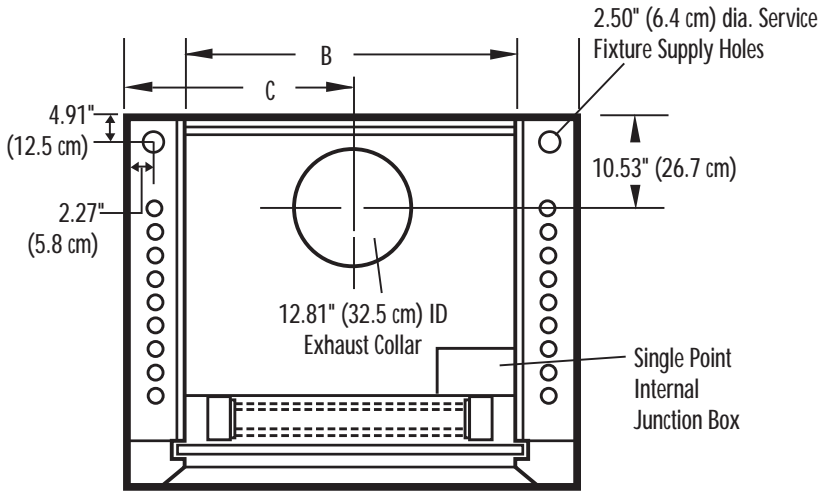

TOP

	A	B	C	D	E
4' Hood					
9750400	48.00"/	38.25"/	24.00"/	39.20"/	30.00"/
9750401	121.9 cm	97.2 cm	61.0 cm	99.6 cm	76.2 cm
9750402	48.00"/	38.25"/	24.00"/	45.20"/	36.00"/
9750403	121.9 cm	97.2 cm	61.0 cm	114.8 cm	91.4 cm
9750404	48.00"/	38.25"/	24.00"/	33.20"/	24.00"/
9750405	121.9 cm	97.2 cm	61.0 cm	84.3 cm	61.0 cm
5' Hood					
9750500	60.00"/	50.25"/	30.00"/	39.20"/	30.00"/
9750501	152.4 cm	127.6 cm	76.2 cm	99.6 cm	76.2 cm
9750502	60.00"/	50.25"/	30.00"/	45.20"/	36.00"/
9750503	152.4 cm	127.6 cm	76.2 cm	114.8 cm	91.4 cm
9750504	60.00"/	50.25"/	30.00"/	33.20"/	24.00"/
9750505	152.4 cm	127.6 cm	76.2 cm	84.3 cm	61.0 cm
6' Hood					
9750600	72.00"/	62.25"/	36.00"/	39.20"/	30.00"/
9750601	182.9 cm	158.1 cm	91.4 cm	99.6 cm	76.2 cm
9750602	72.00"/	62.25"/	36.00"/	45.20"/	36.00"/
9750603	182.9 cm	158.1 cm	91.4 cm	114.8 cm	91.4 cm
9750604	72.00"/	62.25"/	36.00"/	33.20"/	24.00"/
9750605	182.9 cm	158.1 cm	91.4 cm	84.3 cm	61.0 cm

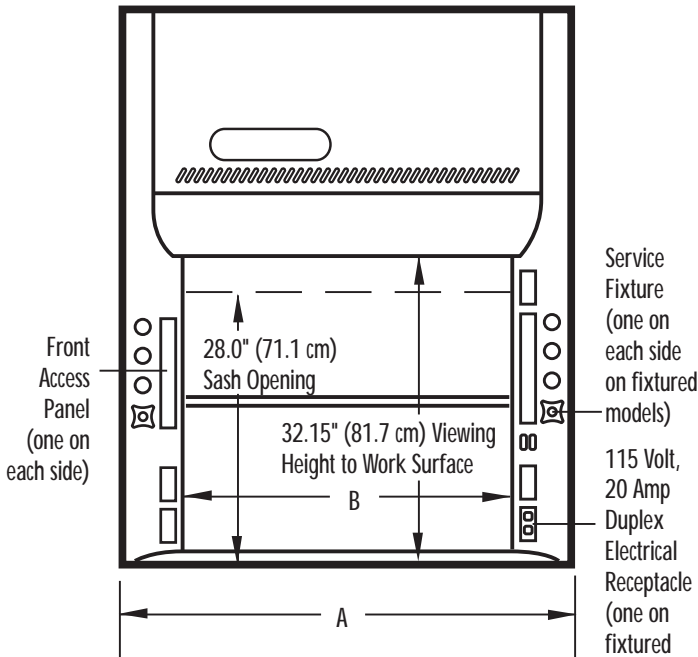

FRONT

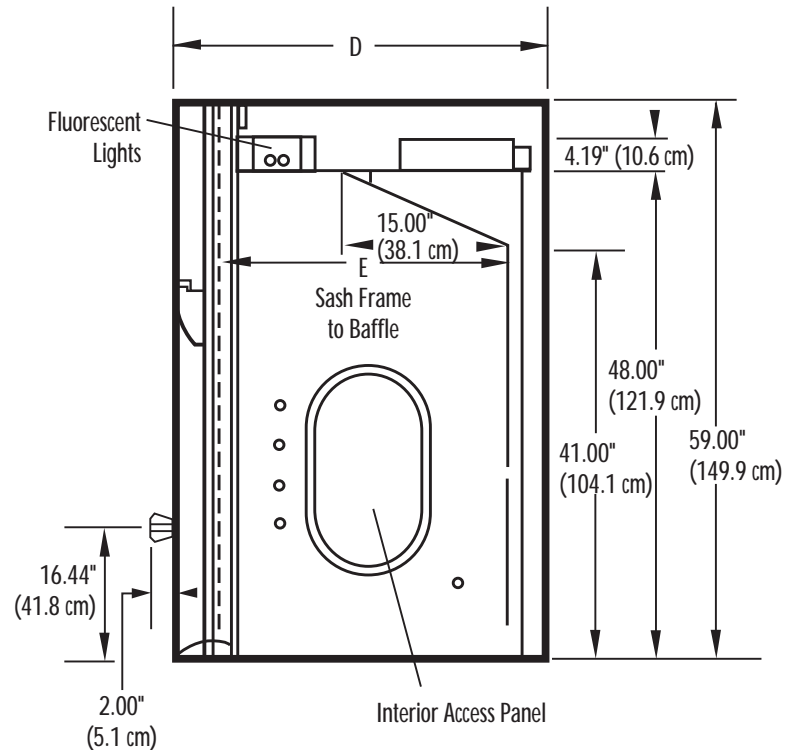

SIDE

Contact Labconco at 800-821-5525 or 816-333-8811 or visit www.labconco.com for detailed AutoCAD drawings.



Dimensional Data

8', 10', 12' and 16' Protector[®]XL™ Benchtop Laboratory Hoods

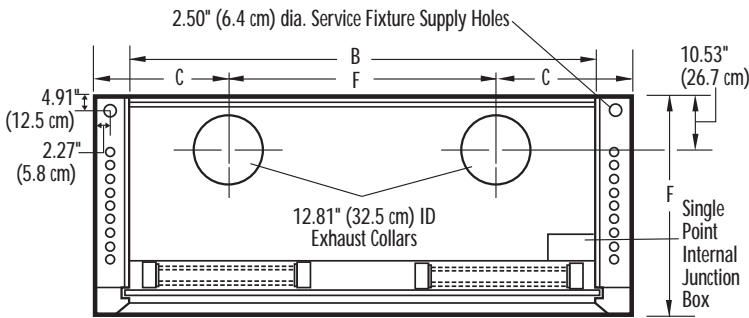

TOP (8', 10', 12')

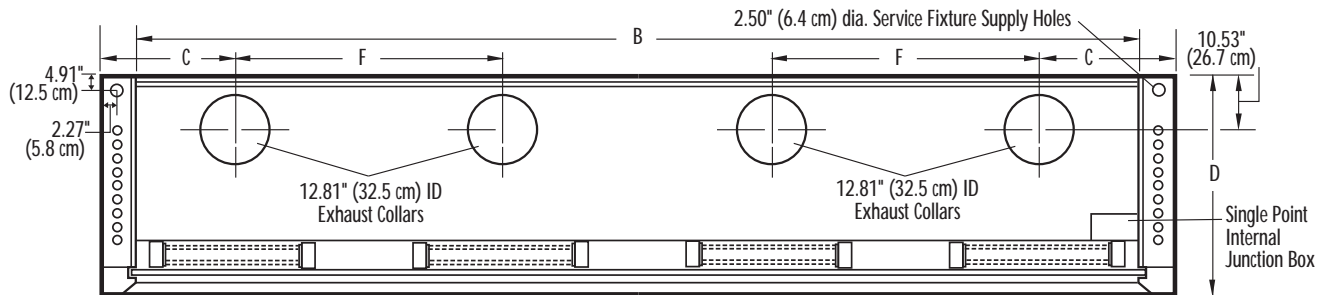

TOP (16')

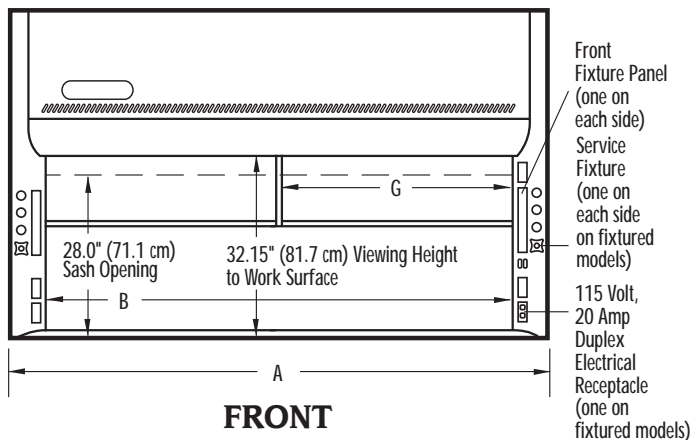

FRONT

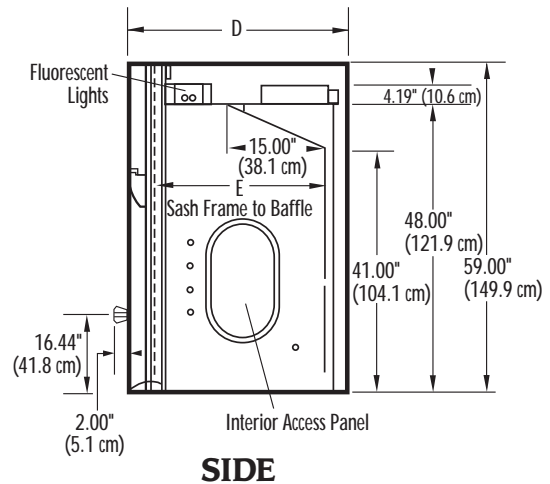

SIDE

	A*	B*	C*	D*	E*	F*	G*
8' Hood							
9700100, 9700101	96.00 (243.8)	86.25 (219.1)	24.00 (61.0)	39.20 (99.6)	30.00 (76.2)	48.00 (121.9)	42.84 (108.8)
9700102, 9700103	96.00 (243.8)	86.25 (219.1)	24.00 (61.0)	45.20 (114.8)	36.00 (91.4)	48.00 (121.9)	42.84 (108.8)
9700104, 9700105	96.00 (243.8)	86.25 (219.1)	24.00 (61.0)	33.20 (84.3)	24.00 (61.0)	48.00 (121.9)	42.84 (108.8)
10' Hood							
9700200, 9700201	120.00 (304.8)	110.25 (280.0)	35.00 (88.9)	39.20 (99.6)	30.00 (76.2)	50.00 (127.0)	54.84 (139.3)
9700202, 9700203	120.00 (304.8)	110.25 (280.0)	35.00 (88.9)	45.20 (114.8)	36.00 (91.4)	50.00 (127.0)	54.84 (139.3)
9700204, 9700205	120.00 (304.8)	110.25 (280.0)	35.00 (88.9)	33.20 (84.3)	24.00 (61.0)	50.00 (127.0)	54.84 (139.3)
12' Hood							
9700300, 9700301	144.00 (365.8)	134.25 (341.0)	41.00 (104.1)	39.20 (99.6)	30.00 (76.2)	62.00 (157.5)	66.84 (169.8)
9700302, 9700303	144.00 (365.8)	134.25 (341.0)	41.00 (104.1)	45.20 (114.8)	36.00 (91.4)	62.00 (157.5)	66.84 (169.8)
9700304, 9700305	144.00 (365.8)	134.25 (341.0)	41.00 (104.1)	33.20 (84.3)	24.00 (61.0)	62.00 (157.5)	66.84 (169.8)
16' Hood							
9700400, 9700401	192.00 (487.7)	182.25 (462.9)	24.00 (61.0)	39.20 (99.6)	30.00 (76.2)	48.00 ¹ (121.9)	44.84 (113.9) End 46.00 (116.8) Center (Four Sashes)
9700402, 9700403	192.00 (487.7)	182.25 (462.9)	24.00 (61.0)	45.20 (114.8)	36.00 (91.4)	48.00 ¹ (121.9)	44.84 (113.9) End 46.00 (116.8) Center (Four Sashes)
9700404, 9700405	192.00 (487.7)	182.25 (462.9)	24.00 (61.0)	33.20 (84.3)	24.00 (61.0)	48.00 ¹ (121.9)	44.84 (113.9) End 46.00 (116.8) Center (Four Sashes)

*Inches (centimeters)

¹Four Collars

Contact Labconco at 800-821-5525 or 816-333-8811 or visit www.labconco.com for detailed AutoCAD drawings.



Dimensional Data

4', 5', 6' and 8' Protector[®]XL™ Floor-Mounted Laboratory Hoods with vertical-rising sashes

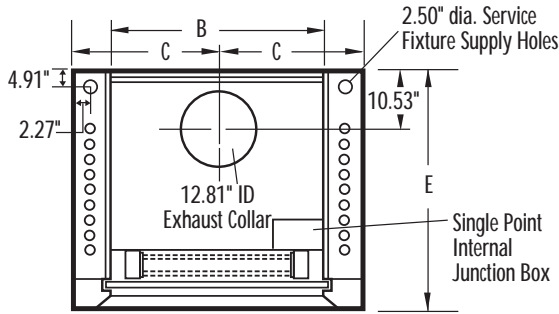

TOP 4', 5', 6'

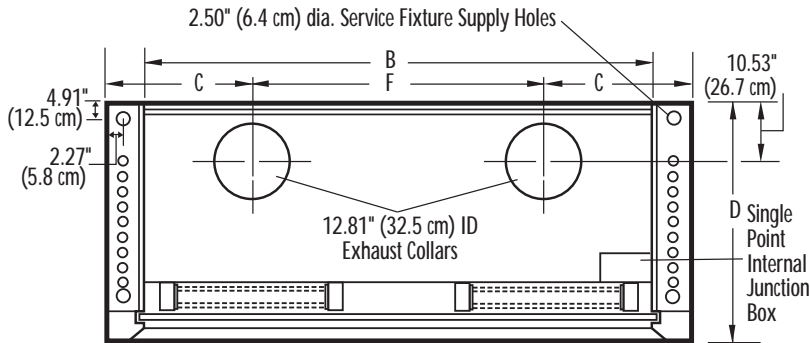

TOP (8')

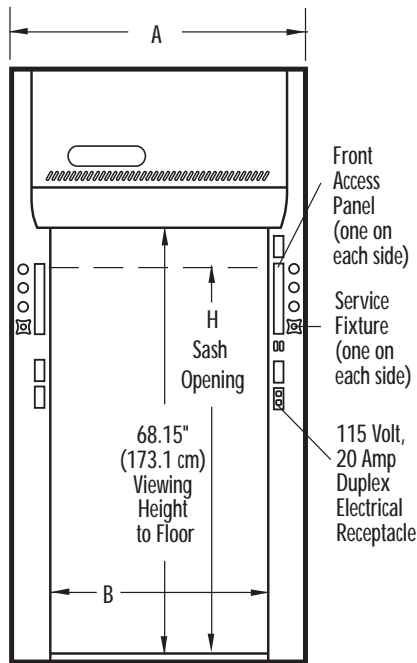

FRONT

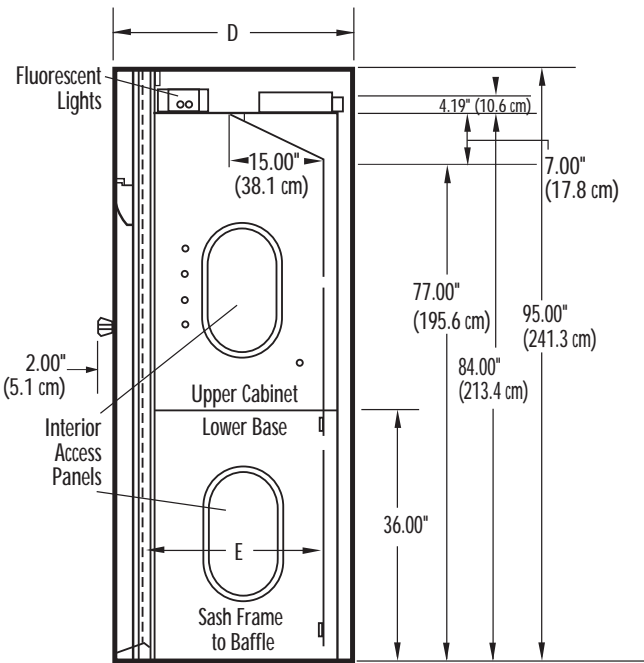

SIDE

	A*	B*	C*	D*	E*	F*	H*
4' Hood							
9860401	48.00 (121.9)	38.25 (97.2)	24.00 (61.0)	39.20 (99.6)	30.00 (76.2)	—	58.81 (149.4)
9860403	48.00 (121.9)	38.25 (97.2)	24.00 (61.0)	45.20 (114.8)	36.00 (91.4)	—	58.81 (149.4)
9860405	48.00 (121.9)	38.25 (97.2)	24.00 (61.0)	57.20 (145.3)	48.00 (121.9)	—	58.81 (149.4)
5' Hood							
9860501	60.00 (152.4)	50.25 (127.6)	30.00 (76.2)	39.20 (99.6)	30.00 (76.2)	—	58.81 (149.4)
9860503	60.00 (152.4)	50.25 (127.6)	30.00 (76.2)	45.20 (114.8)	36.00 (91.4)	—	58.81 (149.4)
9860505	60.00 (152.4)	50.25 (127.6)	30.00 (76.2)	57.20 (145.3)	48.00 (121.9)	—	58.81 (149.4)
6' Hood							
9860601	72.00 (182.9)	62.25 (158.1)	36.00 (91.4)	39.20 (99.6)	30.00 (76.2)	—	58.81 (149.4)
9860603	72.00 (182.9)	62.25 (158.1)	36.00 (91.4)	45.20 (114.8)	36.00 (91.4)	—	58.81 (149.4)
9860605	72.00 (182.9)	62.25 (158.1)	36.00 (91.4)	57.20 (145.3)	48.00 (121.9)	—	58.81 (149.4)
8' Hood							
9700807	96.00 (243.8)	86.25 (219.1)	24.00 (61.0)	39.20 (99.6)	30.00 (76.2)	48.00 (121.9)	59.00 (149.9)
9700809	96.00 (243.8)	86.25 (219.1)	24.00 (61.0)	45.20 (114.8)	36.00 (91.4)	48.00 (121.9)	59.00 (149.9)
9700811	96.00 (243.8)	86.25 (219.1)	24.00 (61.0)	57.20 (145.3)	48.00 (121.9)	48.00 (121.9)	59.00 (149.9)

*Inches (centimeters)

Contact Labconco at 800-821-5525 or 816-333-8811 or visit www.labconco.com for detailed AutoCAD drawings.



Dimensional Data

8', 10', 12' and 16' Protector®XL™ Floor-Mounted Laboratory Hoods with horizontal-sliding sashes

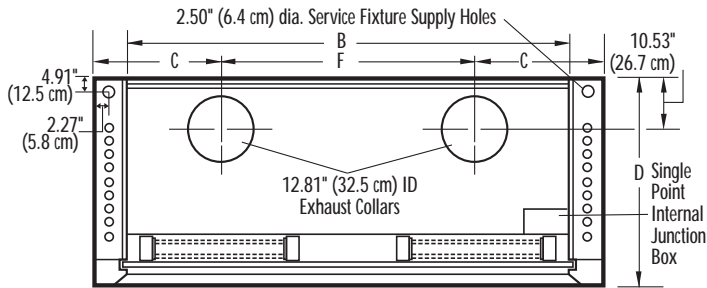

TOP 8', 10', 12'

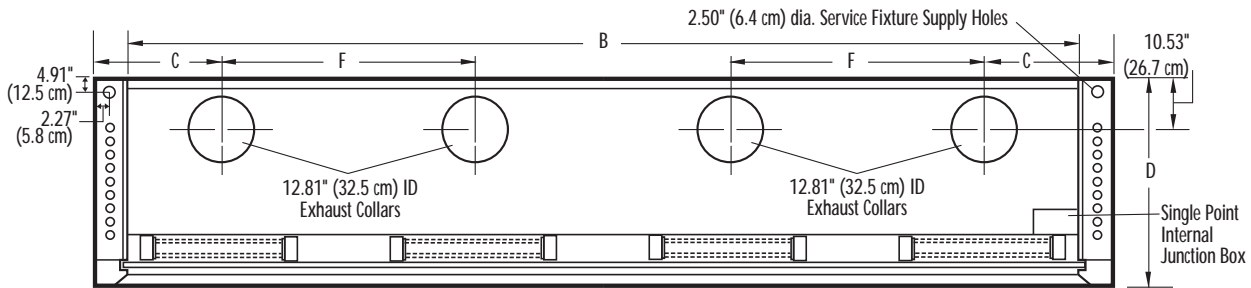

TOP (16')

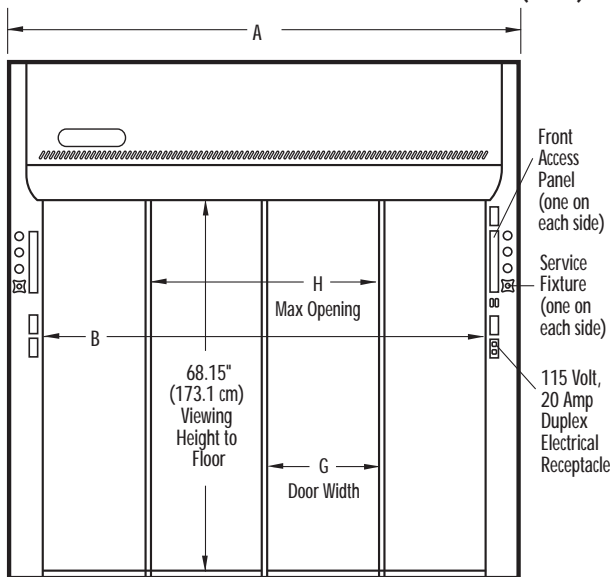

FRONT

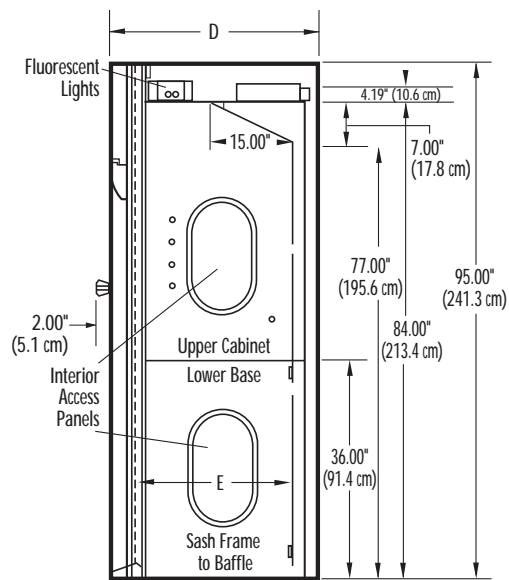

SIDE

	A*	B*	C*	D*	E*	F*	G*	H*
8' Hood								
9700801	96.00 (243.8)	86.25 (219.1)	24.00 (61.0)	39.20 (99.6)	30.00 (76.2)	48.00 (121.9)	22.50 (57.2)	43.25 (109.9)
9700803	96.00 (243.8)	86.25 (219.1)	24.00 (61.0)	45.20 (114.8)	36.00 (91.4)	48.00 (121.9)	22.50 (57.2)	43.25 (109.9)
9700805	96.00 (243.8)	86.25 (219.1)	24.00 (61.0)	57.20 (145.3)	48.00 (121.9)	48.00 (121.9)	22.50 (57.2)	43.25 (109.9)
10' Hood								
9700901	120.00 (304.8)	110.25 (280.0)	35.00 (88.9)	39.20 (99.6)	30.00 (76.2)	50.00 (127.0)	28.50 (72.4)	55.25 (140.3)
9700903	120.00 (304.8)	110.25 (280.0)	35.00 (88.9)	45.20 (114.8)	36.00 (91.4)	50.00 (127.0)	28.50 (72.4)	55.25 (140.3)
9700905	120.00 (304.8)	110.25 (280.0)	35.00 (88.9)	57.20 (145.3)	48.00 (121.9)	50.00 (127.0)	28.50 (72.4)	55.25 (140.3)
12' Hood								
9701001	144.00 (365.8)	134.25 (341.0)	41.00 (104.1)	39.20 (99.6)	30.00 (76.2)	62.00 (157.5)	34.50 (87.6)	67.25 (170.8)
9701003	144.00 (365.8)	134.25 (341.0)	41.00 (104.1)	45.20 (114.8)	36.00 (91.4)	62.00 (157.5)	34.50 (87.6)	67.25 (170.8)
9701005	144.00 (365.8)	134.25 (341.0)	41.00 (104.1)	57.20 (145.3)	48.00 (121.9)	62.00 (157.5)	34.50 (87.6)	67.25 (170.8)
16' Hood								
9716001	192.00 (487.7)	182.25 (462.9)	24.00 (61.0)	39.20 (99.6)	30.00 (76.2)	48.00 ¹ (121.9)	46.50 (118.1)	91.25 (231.8)
9716003	192.00 (487.7)	182.25 (462.9)	24.00 (61.0)	45.20 (114.8)	36.00 (91.4)	48.00 ¹ (121.9)	46.50 (118.1)	91.25 (231.8)
9716005	192.00 (487.7)	182.25 (462.9)	24.00 (61.0)	57.20 (145.3)	48.00 (121.9)	48.00 ¹ (121.9)	46.50 (118.1)	91.25 (231.8)

*Inches (centimeters)

¹Four Collars



Protector® XLE™ Laboratory Hoods



Requires
Ductwork and
Blower

The Protector XLE Laboratory Hood automatically closes to an 18" high sash opening for added safety and to help conserve energy .

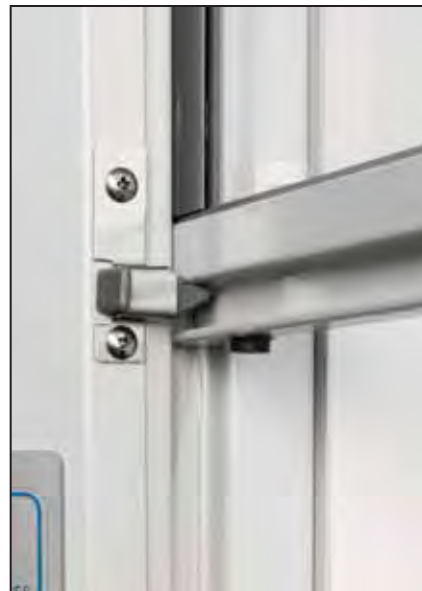

The sash latch holds the sash in the 28" high position for loading. When the latch is released, the sash automatically returns to the 18" operating height position.



Openings on both ends of the air foil allow electrical cord pass through without disrupting airflow. Cords do not block airflow and are out of the way of the operator.



The ergonomic low-profile air foil provides a comfortable surface for arms resting on it and improves operator access to the hood's interior. Patented* Clean-Sweep airflow openings significantly improve airflow.



The integral spill trough prevents spills on the work surface from leaking out the front of the hood. The air foil pivots up to provide access to the spill trough for cleaning.

* U.S. Patent No. 6,461,233



Protector[®] XLE[™] Laboratory Hoods



6' Protector XLE Laboratory Hood 9970600 is shown with SpillStopper Work Surface 9969600, Protector Standard Storage Cabinets 9900700 and 9900400 and Protector Solvent Storage Cabinet 9903100. Blower, ductwork, work surface and base cabinets must be ordered separately.



Requires Ductwork and Blower



All models feature:

- By-pass airflow design.
- Ergonomic, low-profile air foil with aerodynamic Clean-Sweep* airflow openings and ADA-compliant spill trough. The air foil pivots up for cleaning. The spill trough requires no cabinet overhang.
- Electrical cord pass through on both ends of air foil to keep cords out of the way.
- Glacier white, dry powder epoxy-coated steel exterior.
- Chemical-resistant molded composite panel liner and pre-set baffle(s) with flame spread less than 25 per ASTM E-84.
- 3/16" thick tempered safety glass vertical-rising sash with self-closing mechanism, counterbalance system and epoxy-coated aluminum sash handle. When raised, the sash automatically closes to an 18" high sash opening.
- Sash latch at 28" sash opening to hold sash in raised position during loading.
- 35" sash viewing height.
- Removable front and side panels and front and interior service access panels for access to plumbing and electrical wiring.

- Pre-wired T8 fluorescent lighting, light and blower switches for 115 volt, 60 Hz operation.
- Epoxy-coated stainless steel, 12.81" ID exhaust connection(s).

All models conform to the following regulations and standards:

- SEFA 1-2006
- NFPA 45-2004
- ASTM E84-09C
- ASHRAE 110-95
- ANSI Z9.5-2003
- UL 3101-1/61010-1
- CAN/CSA C22.2 No. 1010.1
- UL 1805

Fixed models feature:

- Two pre-plumbed service fixtures with forged brass valves, lower right side with brass tubing for gas and lower left side with copper tubing for cold water. Components for converting either or both fixtures to air and vacuum are provided. **Inlet tubing is not provided.**
- One pre-wired 115 volt, 20 amp electrical duplex receptacle on lower right side.

All models require (not included):

- **Remote Blower.** See back pocket.
- **Ductwork.** See back pocket.
- **Work Surface.** See page 100-104.
- **Base Cabinet or Stand.** See pages 105-116.

Optional accessories for on-site installation include:

- **Service Fixture Kits.** See page 117.
- **Electrical Duplex Kits.** See page 118.
- **Guardian Airflow Monitor Kits.** See page 118.
- **Ceiling Enclosure and Rear Finish Panel Kits.** See page 119.
- **Distillation Grid Kits.** See page 120.
- **Snuffer Fire Extinguishers.** See page 121.

Contact Labconco at **800-821-5525** or **816-333-8811** for ordering information on other hood depths, adjustable baffles, explosion-proof lighting, tissue screens and other sash configurations and for blower sizing assistance.

Self-Closing Sash 60% Open (18")						
Nominal Width	Total Exhaust CFM and Static Pressure		80 fpm S.P.		60 fpm S.P.	
	100 fpm	S.P.	80 fpm	S.P.	60 fpm	S.P.
4 Feet	520	0.09"	420	0.06"	310	0.03"
5 Feet	690	0.12"	550	0.08"	410	0.04"
6 Feet	850	0.15"	680	0.10"	510	0.06"
7 Feet	1020	0.09"	820	0.06"	610	0.03"
8 Feet	1180	0.10"	940	0.06"	710	0.04"

Latched Sash Full Open (28")						
Nominal Width	Total Exhaust CFM and Static Pressure		80 fpm S.P.		60 fpm S.P.	
	100 fpm	S.P.	80 fpm	S.P.	60 fpm	S.P.
4 Feet	790	0.19"	630	0.12"	470	0.07"
5 Feet	1040	0.28"	830	0.18"	620	0.10"
6 Feet	1280	0.33"	1020	0.21"	770	0.12"
7 Feet	1590	0.19"	1220	0.12"	920	0.07"
8 Feet	1780	0.22"	1420	0.14"	1070	0.08"

Exclusive Feature

Heights of switches, electrical receptacle and service fixtures meet requirements of ADA.

*U.S. Patent No. 6,461,233



Ordering Information & Dimensional Data

Protector® XLE™ Laboratory Hoods

Nominal Width	Catalog Number	Exterior Depth*	Interior Depth*	12.81" (32.5 cm) ID Exhaust Collar	Sash*	Fluorescent Lamps	Service Fixtures	Electrical Duplex	Shipping Weight lbs./kg
4 Feet	9970400	39.20" (99.6 cm)	30.00" (76.2 cm)	1	1	2 ea. 25 watt	None	None	400/181
	9970401	39.20" (99.6 cm)	30.00" (76.2 cm)	1	1	2 ea. 25 watt	2	1	430/195
5 Feet	9970500	39.20" (99.6 cm)	30.00" (76.2 cm)	1	1	2 ea. 32 watt	None	None	480/218
	9970501	39.20" (99.6 cm)	30.00" (76.2 cm)	1	1	2 ea. 32 watt	2	1	490/222
6 Feet	9970600	39.20" (99.6 cm)	30.00" (76.2 cm)	1	1	2 ea. 32 watt	None	None	545/247
	9970601	39.20" (99.6 cm)	30.00" (76.2 cm)	1	1	2 ea. 32 watt	2	1	555/252
7 Feet	9970700	39.20" (99.6 cm)	30.00" (76.2 cm)	2	1	2 ea. 32 watt	None	None	620/281
	9970701	39.20" (99.6 cm)	30.00" (76.2 cm)	2	1	2 ea. 32 watt	2	1	630/286
8 Feet	9970800	39.20" (99.6 cm)	30.00" (76.2 cm)	2	1	4 ea. 25 watt	None	None	695/315
	9970801	39.20" (99.6 cm)	30.00" (76.2 cm)	2	1	4 ea. 25 watt	2	1	705/320

*Contact Labconco for Protector XLE Laboratory Hoods in other depths and with top-hung combination sashes.

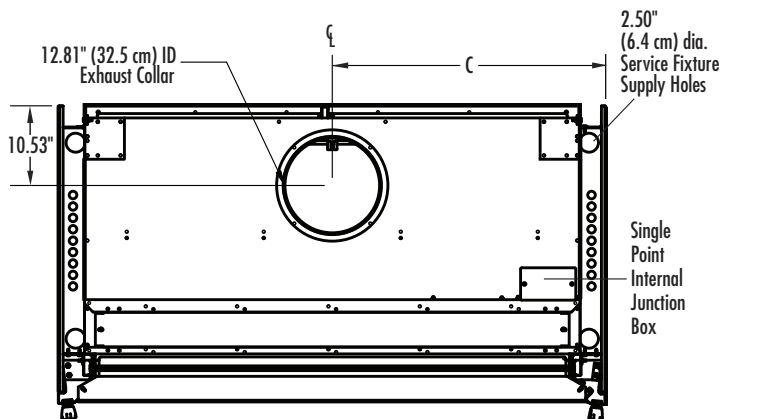

TOP

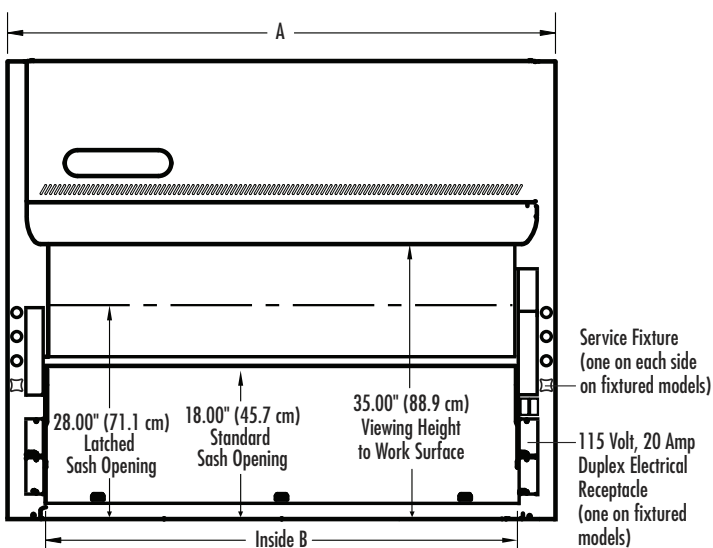

FRONT

	A	B	C
4' Hood	48.00" (121.9 cm)	38.25" (97.2 cm)	24.00" (61.0 cm)
5' Hood	60.00" (152.4 cm)	50.25" (127.6 cm)	30.00" (76.2 cm)
6' Hood	72.00" (182.9 cm)	62.25" (158.1 cm)	36.00" (91.4 cm)
7' Hood	84.00" (213.4 cm)	74.25" (188.6 cm)	21.00" (53.3 cm)*
8' Hood	96.00" (243.8 cm)	86.25" (219.1 cm)	24.00" (61.0 cm)*

* 7' Hoods have two exhaust collars 21.00" both sides from center. 8' Hoods have two exhaust collars 24.00" both sides from center.

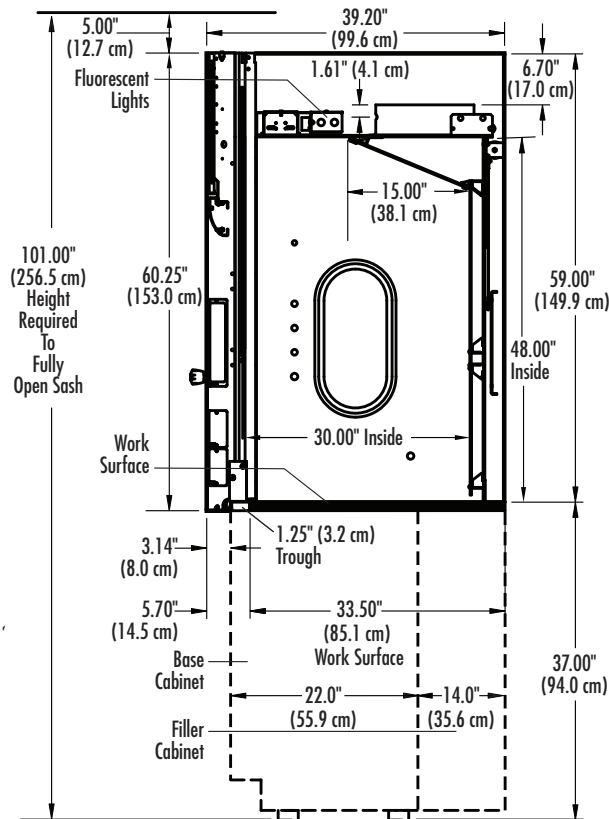

SIDE

SIDE VIEW (Shown with accessory work surface and base cabinet available for all hood widths. Height can vary.)



4' Protector ClassMate Laboratory Hood 6970401 is shown with SpillStopper Work Surface 6986400 and Protector Acid Storage Cabinet 9901000.



Requires
Ductwork and
Blower



Protector® ClassMate® Laboratory Hoods

Features & Benefits

The patented* Protector® ClassMate Laboratory Hoods are designed to meet the needs of instructional laboratories. Clear back and sides and taller front viewing window provide enhanced visibility for conducting chemistry demonstrations or observing

students using the hood. The clear back does not obstruct visibility when hoods are placed back-to-back in an island configuration. Protector ClassMate Hoods are offered in 4', 5' and 6' widths. Models with combination sashes are also available.

Durable and attractive frame is glacier white, dry powder epoxy-coated steel and aluminum.

By-pass airflow design ensures relatively stable face velocities.

Performance tested to ASHRAE 110-1995.

Front panel may be easily removed for lamp replacement and access to electrical supply connections.

Streamlined corner posts provide maximum visibility and working area.

Energy-efficient, rapid-start fluorescent lighting is located behind a laminated safety glass shield and outside the hood interior for corrosion-resistance and easy replacement. Contact Labconco for ordering information on explosion-proof lighting.

Ergonomic 5° angled sash and panel allow closer, more comfortable viewing, without glare.

Clear, tempered safety glass sash, viewing panel, sides, back and baffle provide maximum visibility. All glass components except vertical-rising sashes are removable for cleaning. Laminated safety glass and solid composite sides and back are also available. Contact Labconco for ordering information.

Color-coded service fixtures for gas, air, water, vacuum and other services have remote controls for use regardless of sash position. Four service fixtures are pre-plumbed on fixtured models. Each hood is factory prepared for up to 8 service fixtures (four controlled from the front of the hood and four from the base cabinet).



Static viewing panel above the sash frame creates a 39" viewing height, permitting the hood to be mounted in a low or high position to accommodate persons of different heights and still maintain the same visual accessibility.

Anti-racking vertical-rising sash for smooth operation may be raised from closed to 29° fully open height from the work surface for loading and cleaning. A sash stop limits the working height to 18" to help conserve energy. Exhaust volume and blower sizing are based on the 18" height. When raised, the sash does not extend above the fume hood.

Combination horizontal-sliding/vertical-rising sashes are provided on some models. Two sets of integral sash stops prevent raising the vertical sash above the half-open (15°) and fully-closed positions unless manually defeated by the operator.

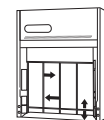

Pre-wired electrical components. Fluorescent lights and switches are factory-wired to the hood's junction boxes. Two electrical duplex receptacles are factory-wired on fixtured models.



Low profile trough below air foil contains spills. The trough is the same depth as the work surface (1.25") and requires no cabinet overhang. The air foil pivots up for cleaning.

Interior cover plates allow easy accessibility to plumbing from the front and inside of the hood.

Ergonomic air foil allows air to sweep the work surface for maximum containment. Clean-Sweep** airflow openings pull inflow air from under the air foil so that clean air continually flows over the air foil creating a constant barrier of protection from contaminants.

ETL-listed. Hoods carry the ETL mark signifying that they are certified to 3101-1/61010-1, UL 1805 and CAN/CSA C22.2 No. 1010.1.

Tissue screen located directly below the exhaust outlet prevents debris from potentially damaging the remote blower.

Large interior working depth of 26" and height of 48" provide ample space to conduct experiments.

Baffle directs airflow to the rear of the interior to provide efficient airflow. For cleaning, the entire baffle may be removed or upper baffle tilted up and the lower baffle tilted down.



* U.S. Design Patent No. 472,645
** U.S. Patent No. 6,461,233



Protector® ClassMate® Laboratory Hoods



Above: 4' Protector ClassMate Laboratory Hood 6970401 is shown with SpillStopper Work Surface 6986400 and Protector Acid Storage Cabinet 9901000. Blower, ductwork, work surface and base cabinet must be ordered separately. **Inset:** 5' Protector ClassMate Combination Sash Laboratory Hood 6971501 is shown with SpillStopper Work Surface 6986500, Protector Solvent Storage Cabinet 9902200 and Protector Acid Storage Cabinet 9901200. Blower, ductwork, work surface and base cabinets must be ordered separately.



Requires
Ductwork and
Blower

All models feature:

- Patented* design.
- Glacier white, dry powder epoxy-coated steel and aluminum frame.
- Ergonomic air foil with aerodynamic Clean-Sweep** airflow openings.
- Low profile, ADA-compliant spill trough that requires no cabinet overhang.
- Removable, clear, 1/4" thick, tempered safety glass sides, back and baffle.
- Pre-wired fluorescent lighting, light switch and blower switch for 115 volt, 60 Hz, 15 amp operation.
- Tissue screen located directly below exhaust outlet.
- Removable front panel and interior cover plates for access to plumbing and electrical wiring.
- Epoxy-coated steel 8.63" ID exhaust connection.

Exclusive Feature

Models series 69704, 69705 and 69706 also feature:

- By-pass airflow design.
- 5° angled, tempered safety glass, 1/4" thick viewing window and 3/16" thick sash with anti-racking shaft and epoxy-coated aluminum frames that provides 39" high visibility.
- Sash stop at 18" height from work surface (60% open). Fully open sash is 29" from work surface.

Models series 69714, 69715 and 69716 also feature:

- Combination horizontal-sliding/vertical-rising sashes** that allow the operator to use the hood with sashes half open either horizontally or vertically. Sash stops at fully closed and 15" height from work surface (50% open). Sash stops at the 50% open (15") and fully-closed positions along with a sash pocket that blocks the upper by-pass and reduces amount of air exhausted.
- Highly visible yellow air foil with recessed sash track.

- 5° angled, tempered safety glass, 1/4" thick sash and stationary viewing panel** to provide viewing height of 39" for visual accessibility regardless of mounting height.
- Epoxy-coated steel sash pocket behind the front panel.

All models conform to the following regulations and standards:

- SEFA 1-2006
- NFPA 45-2004
- ASHRAE 110-95
- ANSI Z9.5-2003
- UL 3101-1/61010-1
- CAN/CSA C22.2 No. 1010.1

Models 6970401, 6970501, 6970601, 6971401, 6971501 and 6971601 feature:

- Four pre-plumbed service fixtures with forged brass valves; three with 0.25" copper tubing for use with cold water, air and vacuum, and one with 0.25" brass tubing for use with gas. **Inlet tubing is not provided.**
- Two pre-wired 115 volt, 15 amp electrical duplex receptacles.

Models 6971401, 6971501 and 6971601 also feature:

- Left-side mounted cold water rigid gooseneck faucet in place of standard service fixture.
- Pre-wired digital airflow monitor.

All models require (not included):

- Remote Blower.** See back pocket.
- Ductwork.** See back pocket.
- Work Surface.** See pages 100-104.
- Base Cabinet.** See pages 105-116.

Optional accessories for on-site installation include:

- Distillation Grid Kits.** See page 120.
- Guardian Airflow Monitors.** See page 118.
- Rear Finish Panel Kits.** See page 120.
- Service Fixtures.** Contact Labconco.

*U.S. Design Patent No. 472,645

** U.S. Patent No. 6,461,233

Heights of switches, electrical receptacles and service fixtures meet requirements of ADA.

Contact Labconco at **800-821-5525** or **816-333-8811** for blower sizing assistance.



Ordering Information & Dimensional Data

Protector® ClassMate® Laboratory Hoods

Total Exhaust CFM and Static Pressure at 18" sash opening height (60% open)*						
Catalog Number	100 fpm	S.P.	80 fpm	S.P.	60 fpm	S.P.
6970400, 6970401	570	0.24"	460	0.16"	340	0.09"
6970500, 6970501	730	0.39"	590	0.26"	440	0.14"
6970600, 6970601	890	0.51"	710	0.33"	540	0.19"

Total Exhaust CFM and Static Pressure at 50% sash opening height horizontally or vertically						
Catalog Number	100 fpm	S.P.	80 fpm	S.P.	60 fpm	S.P.
6971400, 6971401	470	0.16"	380	0.11"	280	0.06"
6971500, 6971501	550	0.22"	440	0.14"	330	0.08"
6971600, 6971601	680	0.30"	550	0.20"	410	0.11"

*Contact Labconco for other sash opening height data.

Nominal Width	Catalog Number	Fluorescent Lamps	Service Fixtures	Electrical Duplexes	Digital Monitor	Shipping Weight lbs./kg
4 Feet	6970400	2 ea. 30 watt	None	None	No	400/181
4 Feet	6970401	2 ea. 30 watt	4	2	No	400/181
4 Feet	6971400	2 ea. 30 watt	None	None	No	485/220
4 Feet	6971401	2 ea. 30 watt	4	2	Yes	485/220
5 Feet	6970500	2 ea. 40 watt	None	None	No	460/209
5 Feet	6970501	2 ea. 40 watt	4	2	No	460/209
5 Feet	6971500	2 ea. 40 watt	None	None	No	570/259
5 Feet	6971501	2 ea. 40 watt	4	2	Yes	570/259
6 Feet	6970600	2 ea. 40 watt	None	None	No	550/249
6 Feet	6970601	2 ea. 40 watt	4	2	No	550/249
6 Feet	6971600	2 ea. 40 watt	None	None	No	680/308
6 Feet	6971601	2 ea. 40 watt	4	2	Yes	680/308

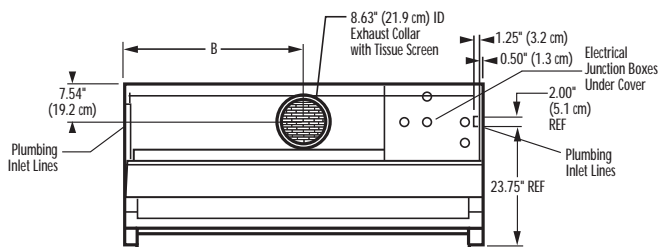

TOP (All Models)

	A*	B*	C*	D*	E*
6970400, 6970401	48.00 (121.9)	24.00 (61.0)	45.00 (114.3)	N/A	25.75 (65.4)
6971400, 6971401	48.00 (121.9)	24.00 (61.0)	45.00 (114.3)	N/A	26.25 (66.7)
6970500, 6970501	60.00 (152.4)	30.00 (76.2)	57.00 (144.8)	N/A	25.75 (65.4)
6971500, 6971501	60.00 (152.4)	30.00 (76.2)	57.00 (144.8)	26.00 (66.0)	26.25 (66.7)
6970600, 6970601	72.00 (182.9)	36.00 (91.4)	69.00 (175.3)	N/A	25.75 (65.4)
6971600, 6971601	72.00 (182.9)	36.00 (91.4)	69.00 (175.3)	32.00 (81.3)	26.25 (66.7)

*Inches (centimeters)

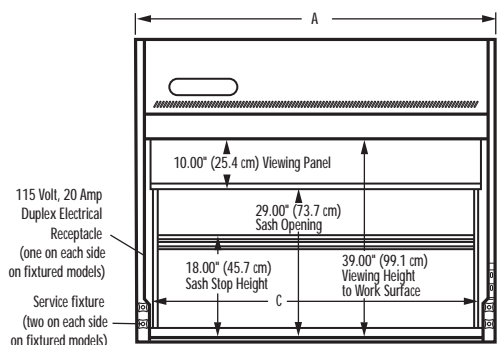

FRONT
(Model series 69704,
69705 and 69706)

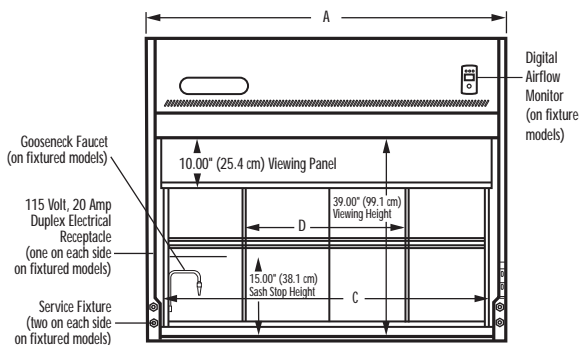

FRONT
(Model series 69714,
69715 and 69716)

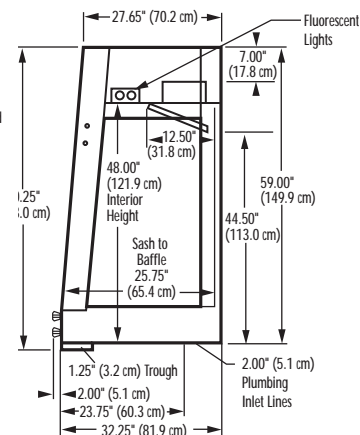

SIDE
(All Models)

Contact Labconco at **800-821-5525** or **816-333-8811** for detailed AutoCAD drawings.



5' Protector Pass-Through Laboratory Hood 9942502 is shown with SpillStopper Work Surface 9972500 and Protector Standard Storage Cabinets 9900200.

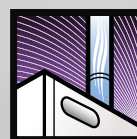

Requires
Ductwork and
Blower



Protector® Pass-Through Laboratory Hoods

Features & Benefits

With sashes on two sides, Protector Pass-Through Laboratory Hoods may be operated from either side while an audible sash alarm sounds to prevent simultaneous opening of both sashes. When mounted in an island or peninsular configuration, the hood's unobstructed viewing from either side make them ideal for con-

ducting chemistry demonstrations or observing students using the hood. An optional right-side mounted viewing window further enhances visibility. These hoods may also be installed in the wall between two rooms. An audible sash alarm sounds when both sashes are opened at the same time.

Front and side panels may be easily removed for lamp replacement and access to sash weight and electrical supply connections.

Durable and attractive frame is glacier white, dry powder epoxy-coated steel and aluminum.

Performance tested to ASHRAE 110-1995.

By-pass airflow design ensures relatively stable face velocities.

Upper baffle directs airflow to the center of the interior to provide efficient airflow.

Streamlined corner posts provide maximum visibility and working area.

Clear, vertical-rising tempered safety glass sashes provide maximum visibility.

Large 15" x 24", right-side mounted, clear, tempered safety glass viewing window is included on some models and provides an additional observation vantage point.

Chemical-resistant, fiberglass-reinforced composite panel liner surpasses all national codes for flame spread and has a bright white surface for excellent light reflectivity.

Pre-wired electrical components. Incandescent light, switches and GFCI electrical duplex receptacle are factory-wired to the hood's junction box.

Factory-prepared for optional accessories. Each hood has four factory-prepared locations for electrical duplexes and two for airflow monitors.

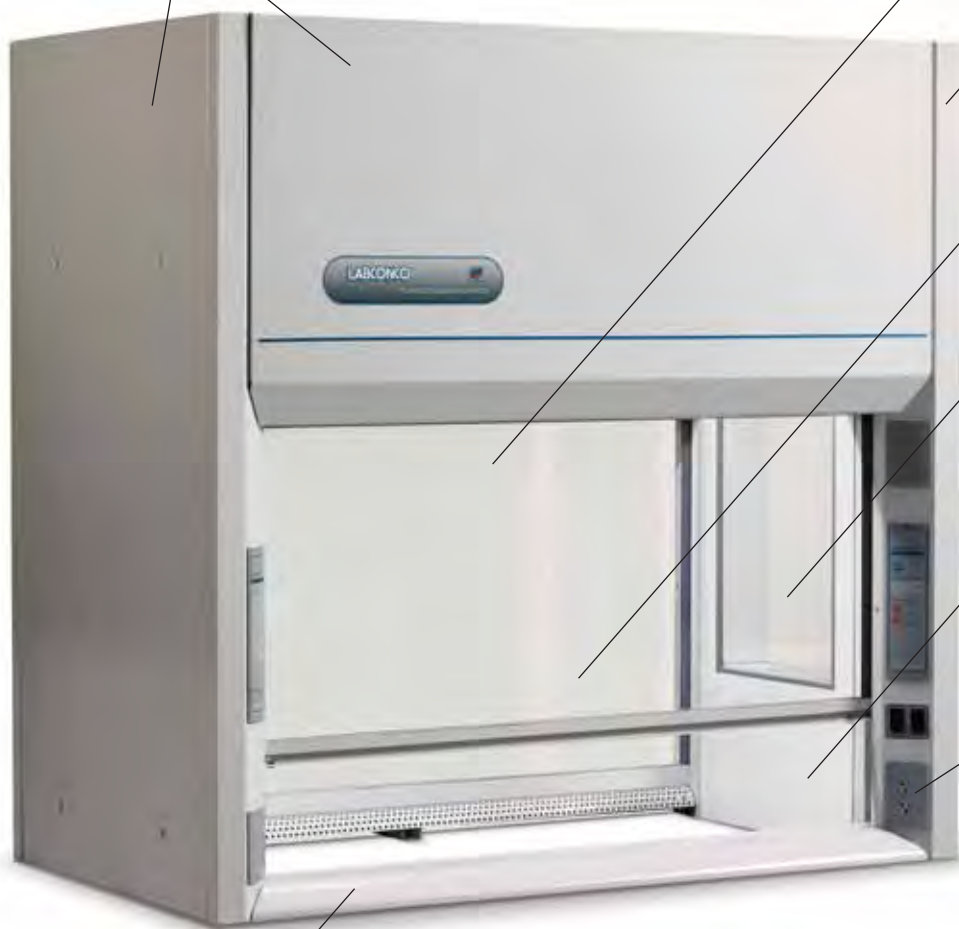

Ergonomic air foils allow air to sweep the work surface for maximum containment. Clean-Sweep* airflow openings pull inflow air from under the air foil so that clean air continually flows over the air foil creating a constant barrier of protection from contaminants.

Audible sash alarm alerts the operator to unsafe conditions. The alarm sounds when both sashes are opened simultaneously and continues until one sash is completely closed.

ETL-listed. Hoods carry the ETL mark signifying that they are certified to 3101-1/61010-1, UL 1805 and CAN/CSA C22.2 No. 1010.1.



 Exclusive Feature

* U.S. Patent No. 6,461,233



Protector® Pass-Through Laboratory Hoods



Requires
Ductwork and
Blower



All models conform to the following regulations and standards:

- SEFA 1-2006
- NFPA 45-2004
- ASTM E84-09C
- ASHRAE 110-95
- ANSI Z9.5-2003
- UL 3101-1/61010-1
- CAN/CSA C22.2 No. 1010.1

Models 9942402, 9942502 and 9942602 feature:

- Clear, 1/4" thick, right-side mounted tempered safety glass side window, 15" x 24".

All models require (not included):

- **Remote Blower.** See back pocket.
- **Ductwork.** See back pocket.
- **Work Surface.** See pages 100-104.
- **Base Cabinet.** See pages 106-116.

Optional accessories for on-site installation include:

- **Sash Stop Kits.** See page 118.
- **Guardian Airflow Monitors.** See page 118.
- **Duplex Electrical Receptacle Kits.** See page 118.
- **Ceiling Enclosure Kits.** See page 119.
- **Distillation Grid Kits.** See page 120.

With Sash Full Open (26")		
Nominal Width	Total Exhaust CFM and Static Pressure	
	100 fpm	S.P.
4 Feet	830	0.26"
5 Feet	1100	0.40"
6 Feet	1350	0.65"
With Sash 60% Open (18")		
Nominal Width	Total Exhaust CFM and Static Pressure	
	100 fpm	S.P.
4 Feet	530	0.10"
5 Feet	700	0.16"
6 Feet	865	0.26"

Contact Labconco at **800-821-5525** or **816-333-8811** for ordering information on service fixtures and blower sizing assistance.

Exclusive Feature

* U.S. Patent No. 6,461,233

** Sash stop required

Heights of switches, electrical receptacle and service fixtures meet requirements of ADA.

All models feature:

- By-pass airflow design.
- Glacier white, dry powder epoxy-coated steel and aluminum frame.
- Chemical-resistant molded composite panel liner and pre-set baffle with flame spread less than 25 per ASTM E-84.
- Ergonomic air foil with aerodynamic Clean-Sweep* airflow openings.
- Two each 3/16" thick tempered safety glass vertical-rising sashes.
- Audible alarm that sounds when both sashes are open at the same time.
- Pre-wired 100-watt vapor-proof incandescent light.
- One pre-wired 115-volt, 20 amp GFCI electrical duplex receptacle on lower right side (one side).
- Pre-wired light and blower switches (one side).
- Removable front and side panels for access to light, electrical wiring and sash cables.
- Epoxy-coated steel 10.09" ID exhaust connection.



Ordering Information & Dimensional Data

Protector® Pass-Through Laboratory Hoods

Nominal Width	Catalog Number	Incandescent Lamp	Service Fixtures	GFCI Electrical Duplex	Viewing Window	Shipping Weight lbs./kg
4 Feet	9942402	1 ea. 100 watt	None	1	Right Side	450/202
4 Feet	9942403	1 ea. 100 watt	None	1	None	460/207
5 Feet	9942502	1 ea. 100 watt	None	1	Right Side	520/235
5 Feet	9942503	1 ea. 100 watt	None	1	None	530/240
6 Feet	9942602	1 ea. 100 watt	None	1	Right Side	610/275
6 Feet	9942603	1 ea. 100 watt	None	1	None	620/280

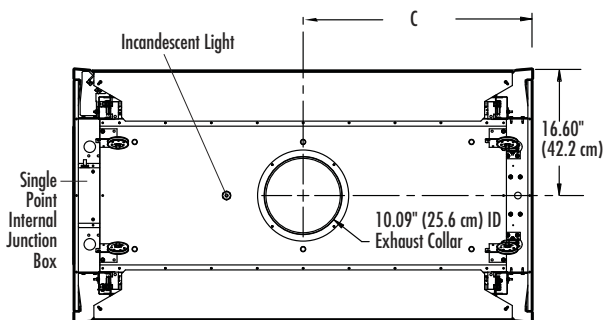

TOP

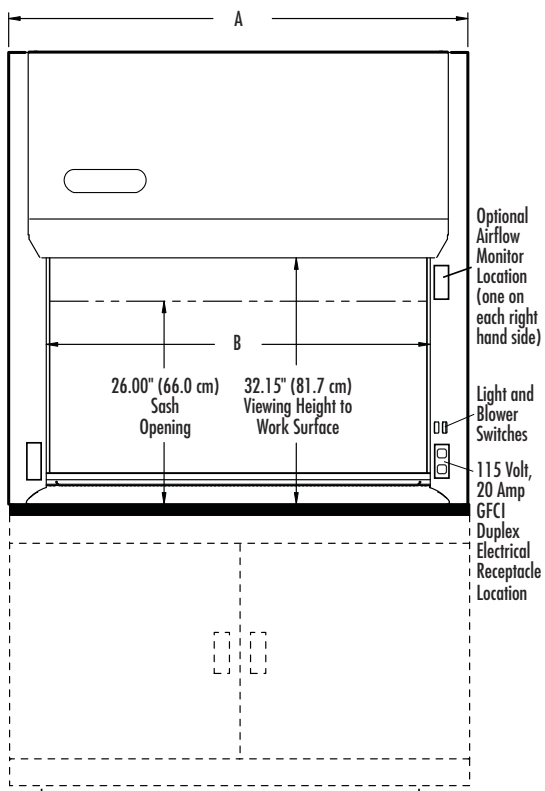

FRONT

	A	B	C
4' Hood	48.00" (121.9 cm)	38.25" (97.2 cm)	24.00" (61.0 cm)
5' Hood	60.00" (152.4 cm)	50.25" (127.6 cm)	30.00" (76.2 cm)
6' Hood	72.00" (182.9 cm)	62.25" (158.1 cm)	36.00" (91.4 cm)

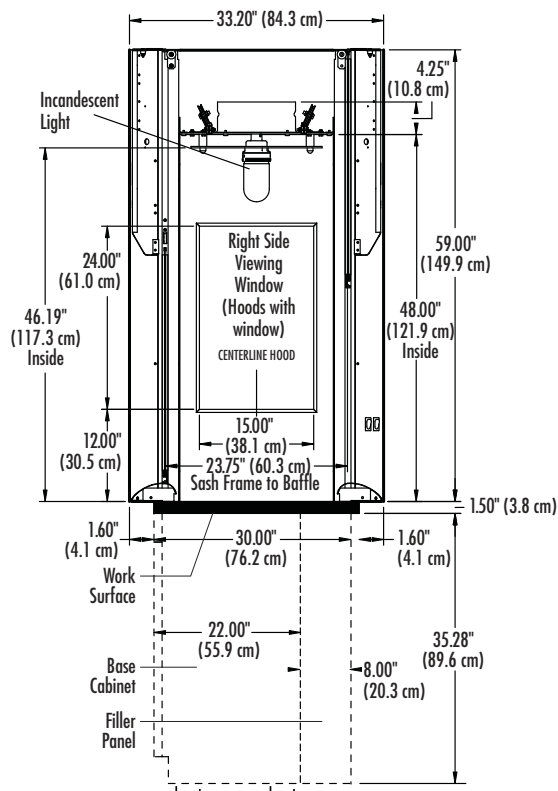

SIDE

SIDE VIEW

(Shown with accessory work surface and base cabinet available for all hood widths. Height can vary.)

Contact Labconco at **800-821-5525** or **816-333-8811** for detailed AutoCAD drawings.



*4' Protector Stainless Steel Radioisotope Laboratory Hood 4882200
is shown with Protector Acid Storage Cabinet 9901000.*



Requires
Ductwork and
Blower



Protector® Stainless Steel Radioisotope Laboratory Hoods

Features & Benefits

Protector Stainless Steel Radioisotope Laboratory Hoods provide protection from applications requiring the use of certain radiochemicals. Available in 4', 5', 6' and 8' widths, these benchtop hoods feature a corrosion-resistant Type 304 stainless steel interior.

The one-piece liner features radiused corners and is free of joints, cracks or crevices to prevent build-up of residue and simplify decontamination procedures.

Front and side panels may be easily removed for lamp replacement and access to electrical and plumbing connections.

By-pass airflow design ensures relatively stable face velocities.

Durable and attractive exterior is glacier white, dry powder epoxy-coated steel.

Pre-set baffle has been designed to provide a uniform face velocity pattern across the sash opening of the hood.

 **Large 28" sash opening** offers superior viewing. When fully open, the sash does not extend above the hood.

Vertical-rising tempered safety glass sash is anti-racking for smooth operation.

 **Service access panels** allow accessibility to plumbing from the front of the hood.

Corrosion-resistant, Type 304 stainless steel liner with integral work surface provides a seamless work area.

Pre-wired electrical components. Fluorescent lights and switches are factory-wired to the hood's single point junction box. One electrical duplex receptacle is factory-wired on fixtured models. Each hood is factory-prepared for up to four electrical duplexes and an airflow monitor.

Hardboard surface to support integral work surface is included.

Fluorescent lighting illuminates the interior. The high-efficiency, instant start, T8 fluorescent lights are located outside the hood interior for corrosion-resistance and easy replacement.

Color-coded service fixtures for gas, air, water, vacuum and other services have remote controls for use regardless of the sash position. Two service fixtures are pre-plumbed. Each corner post is factory-prepared for up to 4 service fixtures (8 fixtures total per hood). **Additional service fixtures require holes drilled in the liner at the factory or on site.**

 **Ergonomic air foil** allows air to sweep the work surface for maximum containment. Clean-Sweep* airflow openings pull inflow air from under the air foil so that clean air continually flows over the air foil creating a constant barrier of protection from contaminants.

ETL-listed. Hoods carry the ETL mark signifying that they are certified to UL 3101-1/61010-1, UL 1805 and CAN/CSA C22.2 No. 1010.1.

Performance tested to ASHRAE 110-1995.



 **Exclusive Feature**

* U.S. Patent No. 6,461,233



Protector® Stainless Steel Radioisotope Laboratory Hoods



Requires
Ductwork and
Blower



4' Protector Stainless Steel Radioisotope Laboratory Hood 4882200 is shown with Protector Acid Storage Cabinet 9901000. Blower, ductwork and base cabinet must be ordered separately.

All models feature:

- By-pass airflow design.
- Glacier white, dry powder epoxy-coated steel exterior.
- Ergonomic air foil with aerodynamic Clean-Sweep* airflow openings.
- Type 304 stainless steel liner (23.5" interior depth) with radiused corners, integral work surface and pre-set baffle(s).
- Black enamel-coated hardboard surface to support the integral work surface.
- 3/16" thick tempered safety glass vertical-rising sash with frame of epoxy-coated aluminum and PVC. Sash does not extend above the hood when fully open.
- Removable front and side panels and front access panels for access to plumbing and electrical wiring.
- Pre-wired T8 fluorescent lighting, light switch and blower switch for 115 volt, 60 Hz operation to single point internal junction box.
- Two pre-plumbed service fixtures with forged brass valves and chrome-plated brass serrated hose connectors, lower right side with brass tubing for gas and lower left side with copper tubing for air. Components for converting either or both fixtures to cold water and vacuum are provided. **Inlet tubing is not provided.**
- One pre-wired 115 volt, 20 amp electrical duplex receptacle on lower right side.
- 11.00" OD Type 304 stainless steel exhaust connection(s).

All models conform to the following regulations and standards:

- SEFA 1-2006
- NFPA 45-2004
- ASTM E84-09C
- ASHRAE 110-95
- ANSI Z9.5-2003
- UL 3101-1/61010-1
- CAN/CSA C22.2 No. 1010.1
- UL 1805

All models require (not included):

- **Dedicated Remote Blower.** See back pocket.
- **Ductwork.** Type 304 stainless steel duct is recommended. Contact Labconco for source recommendations.
- **Base Cabinet or Stand.** See pages 106-116.

Optional accessories for on-site installation include:

- **Service Fixture Kits.** See page 117.
- **Electrical Duplex Kits.** See page 118.
- **Guardian Airflow Monitor Kits.** See page 118.
- **Sash Stop Kits.** See page 121.
- **Ceiling Enclosure and Rear Finish Panel Kits.** See pages 119-120.

With Sash Full Open (28") @ 100 fpm

Nominal Width	Total Exhaust CFM and Static Pressure	
	CFM	S.P.
4 Feet	730	0.20"
5 Feet	960	0.30"
6 Feet	1180	0.50"
8 Feet	1660	0.26"

Contact Labconco at **800-821-5525** or **816-333-8811** for ordering information on additional service fixtures, recommendations on HEPA and carbon filters and for blower sizing assistance.

Exclusive Feature

* U.S. Patent No. 6,461,233

Heights of switches, electrical receptacle and service fixtures meet requirements of ADA.



Ordering Information & Dimensional Data

Protector® Stainless Steel Radioisotope Laboratory Hoods

Nominal Width	Catalog Number	Electrical Requirements	11.00" OD Exhaust Collar(s)	Sash	Fluorescent Lamps	Service Fixtures	Electrical Duplex	Shipping Weight lbs./kg
4 Feet	4882200	115 volts, 60 Hz	1	1	2 ea. 25 watt	2	1	650/295
5 Feet	6082200	115 volts, 60 Hz	1	1	2 ea. 32 watt	2	1	700/318
6 Feet	7282200	115 volts, 60 Hz	1	1	2 ea. 32 watt	2	1	755/342
8 Feet	9682200	115 volts, 60 Hz	2	1	4 ea. 25 watt	2	1	865/392

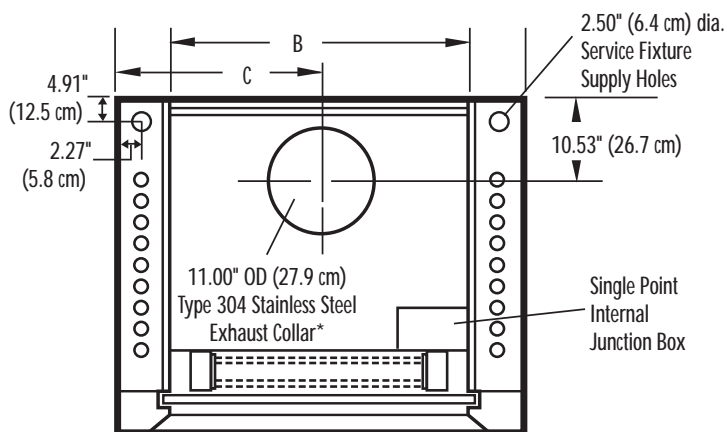

TOP

	A	B	C
4' Hood	48.00" (121.9 cm)	38.25" (97.2 cm)	24.00" (97.2 cm)
5' Hood	60.00" (152.4 cm)	50.25" (127.6 cm)	30.00" (76.2 cm)
6' Hood	72.00" (182.9 cm)	62.25" (158.1 cm)	36.00" (91.4 cm)
8' Hood	96.00" (243.8 cm)	86.25" (219.1 cm)	24.00" (61.0 cm)*

* 8' model has two exhaust collars, 24.00" on each side of centerline

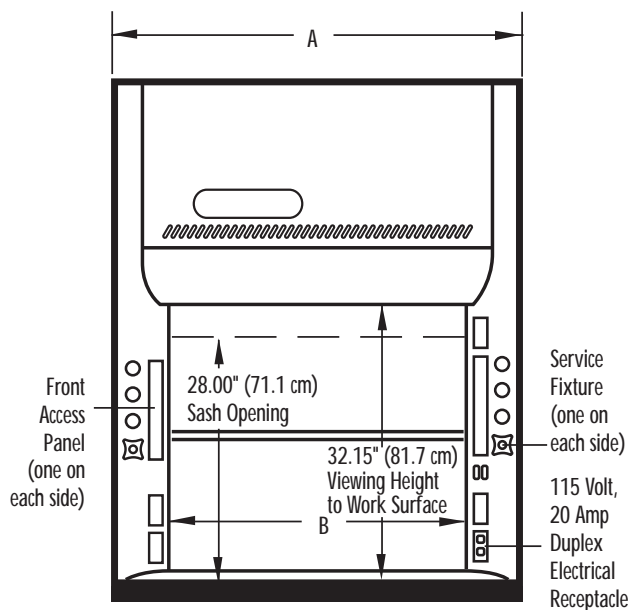

FRONT

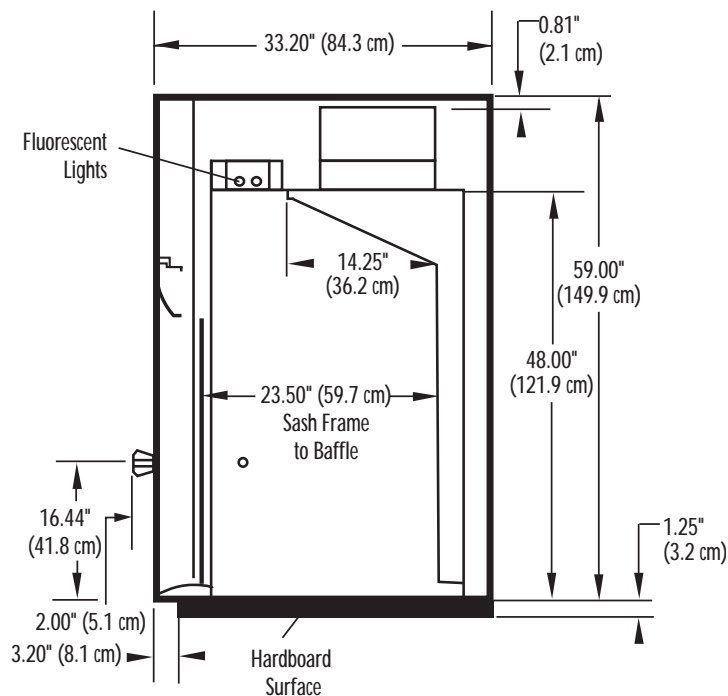

SIDE

Contact Labconco at 800-821-5525 or 816-333-8811 or visit www.labconco.com for detailed AutoCAD drawings.



4' Protector Stainless Steel Perchloric Acid Laboratory Hood 4882100 is shown with Protector Acid Storage Cabinet 9901000.



Requires
Ductwork and
Blower



Protector® Stainless Steel Perchloric Acid Laboratory Hoods

Features & Benefits

Protector Stainless Steel Perchloric Acid Laboratory Hoods are designed specifically for procedures involving the use of perchloric acid. They feature an internal washdown system, integral work surface and drainage trough so that they may be thoroughly rinsed

after each use to prevent the accumulation of potentially reactive perchloric salts. Available in 4', 5', 6' and 8' widths, these bench-top hoods feature a corrosion-resistant Type 316 stainless steel interior to withstand reaction from perchloric acid.

Front and side panels may be easily removed for lamp replacement and access to electrical and plumbing connections.

By-pass airflow design ensures relatively stable face velocities.

Durable and attractive exterior is glacier white, dry powder epoxy-coated steel.

Performance tested to ASHRAE 110-1995.



Pre-set baffle has been designed to provide a uniform face velocity pattern across the sash opening of the hood.

 **Large 28" sash opening** offers superior viewing. When fully open, the sash does not extend above the hood.

Vertical-rising tempered safety glass sash is anti-racking for smooth operation.

 **Service access panels** allow accessibility to plumbing from the front of the hood.

Corrosion-resistant, Type 316 stainless steel liner with integral work surface and drainage trough provides a seamless work area.

Pre-wired electrical components. Fluorescent lights, switches and one 115 volt, 60 Hz electrical duplex receptacle are factory-wired to the hood's single point junction box. Each hood is factory-prepared for up to four electrical duplexes and an airflow monitor.

Hardboard surface to support integral work surface is included.

Fluorescent lighting illuminates the interior. The high efficiency, instant start T8 fluorescent lights are located outside the hood interior for corrosion-resistance and easy replacement.

ETL-listed. Hoods carry the ETL mark signifying that they are certified to UL 3101-1/61010-1, UL 1805 and CAN/CSA C22.2 No. 1010.1.

Color-coded service fixtures for gas, air, water, vacuum and other services have remote controls for use regardless of the sash position. Two service fixtures are pre-plumbed. Corner posts are factory-prepared for up to four remote control knobs (eight fixtures total per hood). **Additional service fixtures require holes drilled in the liner at the factory or on site.**

Built-in washdown system facilitates the removal of hazardous perchlorates from behind the baffle. The system consists of pre-plumbed internal piping, spray nozzles and upper left side-mounted remote control knob.

 **Ergonomic air foil** allows air to sweep the work surface for maximum containment. Clean-Sweep* airflow openings pull inflow air from under the air foil so that clean air continually flows over the air foil creating a constant barrier of protection from contaminants.



* U.S. Patent No. 6,461,233

 **Exclusive Feature**



Protector® Stainless Steel Perchloric Acid Laboratory Hoods



Requires Ductwork and Blower



- One pre-wired 115 volt, 20 amp electrical duplex receptacle on lower right side.
- 11" OD Type 316 stainless steel exhaust connection(s).

All models conform to the following regulations and standards:

- SEFA 1-2006
- NFPA 45-2004
- ASTM E84-09C
- ASHRAE 110-95
- ANSI Z9.5-2003
- UL 3101-1/61010-1
- CAN/CSA C22.2 No. 1010.1
- UL 1805

All models require (not included):

- **Dedicated remote PVC Blower.** See back pocket.
- **Wash Rings and other ductwork.** See back pocket.
- **Base Cabinet or Stand.** See pages 106-116.

Optional accessories for on-site installation include:

- **Service Fixture Kits.** See page 117.
- **Washdown Valve Kit.** See page 118.
- **Electrical Duplex Kits.** See page 118.
- **Guardian Airflow Monitor Kits.** See page 118.
- **Ceiling Enclosure and Rear Finish Panel Kits.** See page 120.
- **Sash Stop Kits.** See pages 119-120.

4' Protector Stainless Steel Perchloric Acid Laboratory Hood 4882100 is shown with Protector Acid Storage Cabinet 9901000. Blower, ductwork and base cabinet must be ordered separately.

All models feature:

- By-pass airflow design.
- Glacier white, dry powder epoxy-coated steel exterior.
- Ergonomic air foil with aerodynamic Clean-Sweep* airflow openings.
- Type 316 stainless steel liner (23.5" interior depth) with radiused corners, integral work surface, drainage trough and pre-set baffle(s).
- Black enamel-coated hardboard surface to support the integral work surface.
- 3/16" thick tempered safety glass vertical-rising sash with frame of epoxy-coated aluminum and PVC. Sash does not extend above the hood when fully open.
- Removable front and side panels and front access panels for access to plumbing and electrical wiring.
- Pre-wired T8 fluorescent lighting, light switch and blower switch for 115 volt, 60 Hz operation to single point internal junction box.

- Built-in washdown system with internal piping and spray nozzles with maximum flow rate from 0.5 -1.0 GPM. Include upper left side-mounted remote control fixture with forged brass valve with maximum flow rate of 3 GPM and maximum working pressure ranging from 10 to 40 psi depending on number of hood's spray nozzles (see page 59). Valve is capable of supplying water to hood's spray nozzles and, except for 8' models, one wash ring (wash rings not included).
- Washdown fitting located on top of hood to facilitate connection to external wash rings (wash rings not included).
- Two pre-plumbed service fixtures with forged brass valves and chrome-plated brass serrated hose connectors, lower right side with brass tubing for gas and lower left side with copper tubing for air. Components for converting either or both fixtures to cold water and vacuum are provided. **Inlet tubing is not provided.**

With Sash Full Open (28") @ 100 fpm

Nominal Width	Total Exhaust CFM and Static Pressure	
	CFM	S.P.
4 Feet	730	0.20"
5 Feet	960	0.30"
6 Feet	1180	0.50"
8 Feet	1660	0.26"

Contact Labconco at **800-821-5525** or **816-333-8811** for ordering information on additional service fixtures and blower sizing assistance.

Exclusive Feature

* U.S. Patent No. 6,461,233



Ordering Information & Dimensional Data

Protector® Stainless Steel Perchloric Acid Laboratory Hoods

Nominal Width	Catalog Number	Electrical Requirements	11.00" OD Exhaust Collar(s)	Sash	Fluorescent Lamps	Service Fixtures	Electrical Duplex	Spray Nozzles	Shipping Weight lbs./kg
4 Feet	4882100	115 volts, 60 Hz	1	1	2 ea. 25 watt	2	1	3 (10-40 psi*)	755/342
5 Feet	6082100	115 volts, 60 Hz	1	1	2 ea. 32 watt	2	1	4 (10-30 psi*)	810/367
6 Feet	7282100	115 volts, 60 Hz	1	1	2 ea. 32 watt	2	1	4 (10-30 psi*)	870/395
8 Feet	9682100	115 volts, 60 Hz	2	1	4 ea. 25 watt	2	1	6 (10 psi*)	990/449

* Working pressure for each spray nozzle.

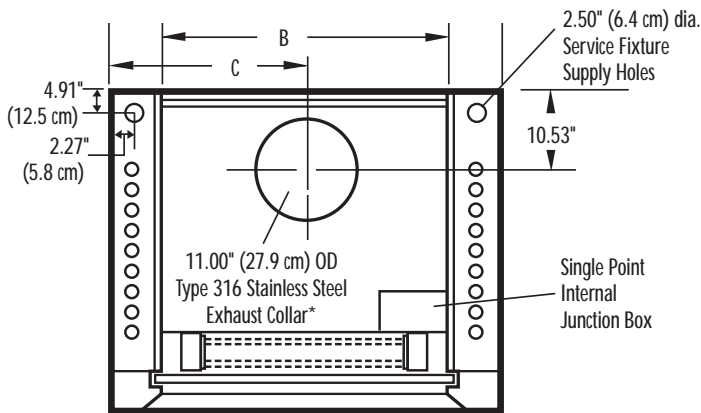

TOP

	A	B	C	D	E
4' Hood	48.00" (121.9 cm)	38.25" (97.2 cm)	24.00" (61.0 cm)	34.00" (86.4 cm)	14.88" (37.8 cm)
5' Hood	60.00" (152.4 cm)	50.25" (127.6 cm)	30.00" (76.2 cm)	46.00" (116.8 cm)	20.88" (53.0 cm)
6' Hood	72.00" (182.9 cm)	62.25" (158.1 cm)	36.00" (91.4 cm)	58.00" (147.3 cm)	26.88" (68.3 cm)
8' Hood	96.00" (243.8 cm)	86.25" (219.1 cm)	24.00** (61.0 cm)	82.00" (208.3 cm)	38.88" (98.8 cm)

* 8' model has two exhaust collars, 24.00" on each side of centerline

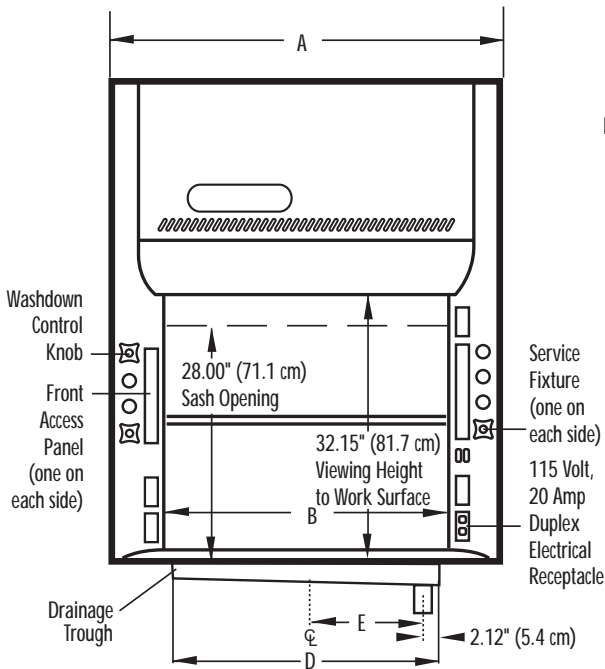

FRONT

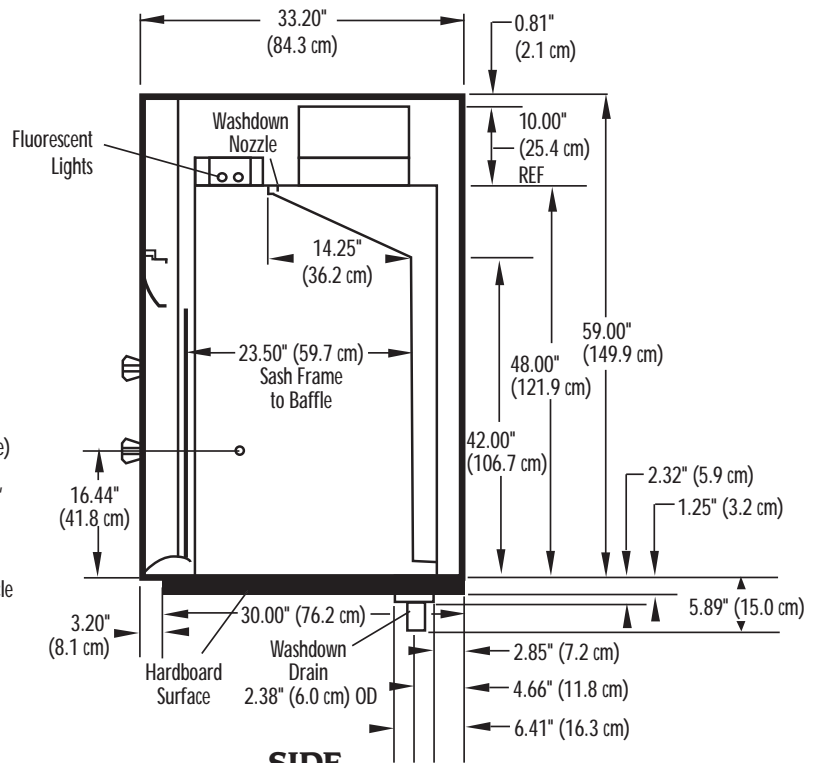

SIDE

Contact Labconco at **800-821-5525** or **816-333-8811** or visit www.labconco.com for detailed AutoCAD drawings.



*4' Protector PVC Perchloric Acid Laboratory Hood 4882400
is shown with Protector Acid Storage Cabinet 9901000.*



Requires
Ductwork and
Blower



Protector® PVC Perchloric Acid & Acid Digestion Laboratory Hoods

Features & Benefits

Protector PVC Perchloric Acid Laboratory Hoods feature an internal washdown system, integral work surface and drainage trough so that they may be thoroughly rinsed after each use to prevent the accumulation of potentially reactive perchloric salts. The liner of Type 1 unplasticized polyvinyl chloride is designed to withstand

reaction from perchloric acid and other highly corrosive inorganic chemicals that do not involve high temperatures. Protector PVC Acid Digestion Laboratory Hoods feature a Lexan® sash, which is recommended for applications involving the use of acids including hydrofluoric acid but not perchloric acid.

Durable and attractive exterior is glacier white, dry powder epoxy-coated steel.

By-pass airflow design ensures relatively stable face velocities.

Front and side panels may be easily removed for lamp replacement and access to electrical and plumbing connections.

Performance tested to ASHRAE 110-1995.



Pre-set baffle has been designed to provide a uniform face velocity pattern across the sash opening of the hood.

Large 28" sash opening offers superior viewing. When fully open, the sash does not extend above the hood.

Vertical-rising tempered safety glass sash is anti-racking for smooth operation. Protector PVC Acid Digestion Hoods feature a Lexan® polycarbonate sash that resists fogging or etching when exposed to hydrofluoric acid fumes.

Service access panels allow accessibility to plumbing from the front of the hood.

Corrosion-resistant liner of Type 1 unplasticized PVC with integral work surface provides a crevice-free work area and withstands low heat up to 160° F.

Pre-wired electrical components. Fluorescent lights, switches and one 115 volt, 60 Hz electrical duplex receptacle are factory-wired to the hood's single point junction box. Each hood is factory-prepared for up to four electrical duplexes and an airflow monitor.

Hardboard surface to support integral work surface is included.

Fluorescent lighting illuminates the interior. The high efficiency, instant start T8 fluorescent lights are located outside the hood interior for corrosion-resistance and easy replacement.

ETL-listed. Hoods carry the ETL mark signifying that they are certified to UL 3 101-1/61010-1, UL 1805 and CAN/CSA C22.2 No. 1010.1.

Color-coded service fixtures for gas, air, water, vacuum and other services have remote controls for use regardless of the sash position. Two service fixtures are pre-plumbed. Corner posts are factory-prepared for up to 4 remote control knobs (8 fixtures total per hood). **Additional service fixtures require holes drilled in the liner at the factory or on site.**

Built-in washdown system facilitates the removal of hazardous perchlorates and chemical residue from hood interior. The system consists of pre-plumbed internal piping, spray nozzles and upper left side-mounted remote control knob.

Ergonomic air foil allows air to sweep the work surface for maximum containment. Clean-Sweep** airflow openings pull inflow air from under the air foil so that clean air continually flows over the air foil creating a constant barrier of protection from contaminants.



* Lexan is a registered trademark of General Electric Company

** U.S. Patent No. 6,461,233





Protector® PVC Perchloric Acid & Acid Digestion Laboratory Hoods



4' Protector PVC Perchloric Acid Laboratory Hood 4882400 is shown with Protector Acid Storage Cabinet 9901000. Blower, ductwork and base cabinet must be ordered separately.



Requires Ductwork and Blower

All models feature:

- By-pass airflow design.
- Glacier white, dry powder epoxy-coated steel exterior.
- Ergonomic air foil with aerodynamic Clean-Sweep® airflow openings.
- Heat-welded Type 1 unplasticized PVC liner (30.0" interior depth) with integral work surface, drainage trough and pre-set baffle(s). PVC withstands maximum continuous operating temperature of 140° F and has a flame spread less than 25 per ASTM E-84.
- Hardboard surface to support the integral work surface.
- Removable front and side panels and front access panels for access to plumbing and electrical wiring.
- Pre-wired T8 fluorescent lighting, light switch and blower switch for 115 volt, 60 Hz operation to single point internal junction box.
- Built-in washdown system with internal piping and spray nozzles with maximum flow rate from 0.5 -1.0 GPM. Include

upper left side-mounted remote control fixture with forged brass valve with maximum flow rate of 3 GPM and maximum working pressure ranging from 10 to 40 psi depending on number of hood's spray nozzles (see page 63). Valve is capable of supplying water to hood's spray nozzles and, except for 8' models, one wash ring (wash rings not included).

- Sash that does not extend above the hood when fully open.
- Washdown fitting located on top of hood facilitates connection to external wash rings (wash rings not included).
- Two pre-plumbed service fixtures with forged brass valves, lower right side with brass tubing and plastic serrated hose connector for gas and lower left side with copper tubing and gray PVC rigid gooseneck faucet for cold water. Components for converting the lower right fixture to air or vacuum are provided. **Inlet tubing is not provided.**
- One pre-wired 115 volt, 20 amp electrical duplex receptacle on lower right side.
- 12.75" OD PVC exhaust connection(s).

Protector PVC Perchloric Acid Laboratory Hoods feature:

- 3/16" thick tempered safety glass vertical-rising sash with frame of epoxy-coated aluminum and PVC. Glass is suitable for perchloric acid use.

Protector PVC Acid Digestion Laboratory Hoods feature:

- 1/4" thick Lexan polycarbonate vertical-rising sash with frame of epoxy-coated aluminum and PVC. Lexan resists etching by hydrofluoric acid fumes.

All models conform to the following regulations and standards:

- SEFA 1-2006
- NFPA 45-2004
- ASTM E84-09C
- ASHRAE 110-95
- ANSI Z9.5-2003
- UL 3101-1/61010-1
- CAN/CSA C22.2 No. 1010.1
- UL 1805

All models require (not included):

- **Dedicated remote PVC Blower.** See back pocket.
- **Wash Rings and other ductwork.** See back pocket.
- **Base Cabinet or Stand.** See pages 106-116.

Optional accessories for on-site installation include:

- **Service Fixture Kits.** See page 117.
- **Washdown Valve Kit.** See page 118.
- **Electrical Duplex Kits.** See page 118.
- **Guardian Airflow Monitor Kits.** See page 118.
- **Ceiling Enclosure and Rear Finish Panel Kits.** See pages 119-120.

With Sash Full Open (28") @ 100 fpm

Nominal Width	Total Exhaust CFM and Static Pressure	
	CFM	S.P.
4 Feet	730	0.17"
6 Feet	1180	0.38"
8 Feet	1660	0.22"

Contact Labconco at **800-821-5525** or **816-333-8811** for ordering information on tissue screens and blower sizing assistance.



Exclusive Feature

* U.S. Patent No. 6,461,233



Ordering Information & Dimensional Data

Protector® PVC Perchloric Acid & Acid Digestion Laboratory Hoods

Nominal Width	Catalog Number	Electrical Requirements	12.75" OD Exhaust Collar(s)	Sash	Fluorescent Lamps	Service Fixtures	Electrical Duplex	Spray Nozzles	Shipping Weight lbs./kg
---------------	----------------	-------------------------	-----------------------------	------	-------------------	------------------	-------------------	---------------	-------------------------

Protector PVC Perchloric Acid Laboratory Hoods

4 Feet	4882300	115 volts, 60 Hz	1	1	2 ea. 25 watt	2	1	3 (10-40 psi*)	735/333
6 Feet	7282300	115 volts, 60 Hz	1	1	2 ea. 32 watt	2	1	4 (10-30 psi*)	850/386
8 Feet	9682300	115 volts, 60 Hz	2	1	4 ea. 25 watt	2	1	6 (10 psi*)	970/440

Protector PVC Acid Digestion Laboratory Hoods

4 Feet	4882400	115 volts, 60 Hz	1	1	2 ea. 25 watt	2	1	3 (10-40 psi*)	735/333
6 Feet	7282400	115 volts, 60 Hz	1	1	2 ea. 32 watt	2	1	4 (10-30 psi*)	850/386
8 Feet	9682400	115 volts, 60 Hz	2	1	4 ea. 25 watt	2	1	6 (10 psi*)	970/440

*Working pressure for each spray nozzle.

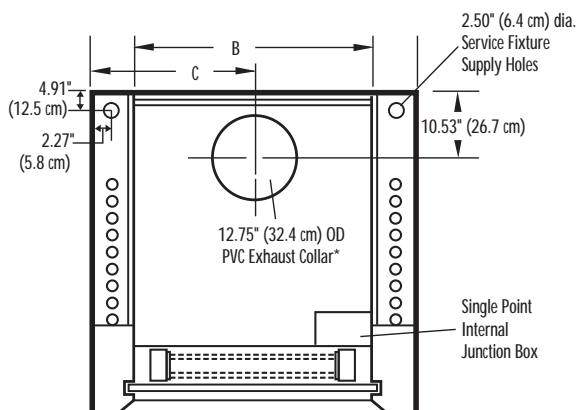

TOP

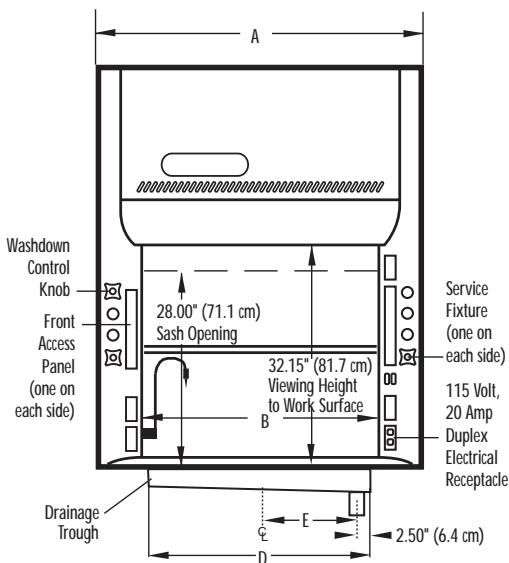

FRONT

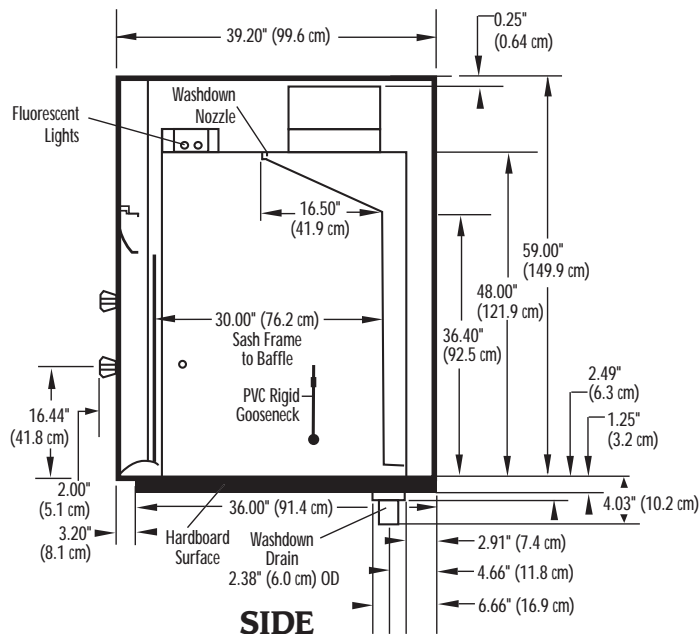

SIDE

	A	B	C	D	E
4' Hood	48.00" (121.9 cm)	38.25" (97.2 cm)	24.00" (61.0 cm)	34.00" (86.4 cm)	14.50" (36.8 cm)
6' Hood	72.00" (182.9 cm)	62.25" (158.1 cm)	36.00" (91.4 cm)	58.00" (147.3 cm)	26.50" (67.3 cm)
8' Hood	96.00" (243.8 cm)	86.25" (219.1 cm)	24.00** (61.0 cm)	82.00" (208.3 cm)	38.50" (97.8 cm)

* 8' model has two exhaust collars, 24.00" on each side of centerline

Contact Labconco at **800-821-5525** or **816-333-8811** for detailed AutoCAD drawings.



Requires
Ductwork and
Blower

Basic 47 Laboratory Hood with built-in blower 2247300 is shown with Flat Solid Epoxy Work Surface 4882803 and Protector Acid Storage Cabinet 9901000.

***Inset:** Basic 70 Laboratory Hood 2246400 is shown with Flat Solid Epoxy Work Surface 4882804 and two Protector Standard Storage Cabinets 9900100.*



Requires
Ductwork



Basic™ Laboratory Hoods

Features & Benefits

Basic 47 and 70 Laboratory Hoods are designed specifically for modular laboratories, classrooms and light duty applications where safe ventilation is required.

Constructed of epoxy-coated steel, Basic Hoods are economical and have a smaller overall height and depth than traditional hoods so they fit in areas with low ceilings or narrow aisles. Choose from 4' and 6' widths.

Front panel may be removed for access to blower and electrical connections.

 **Versatile blower** mounts on top of the hood liner or in a remote location. Hoods are also available without blower.

CE mark*. Contact Labconco for specific 230 volt, 50 Hz models that conform to CE (European Community) requirements for electrical safety and electromagnetic compatibility.

Two-piece baffle is adjustable.

Durable and attractive exterior is glacier white, dry powder epoxy-coated steel.

The right side fixture panel is factory-prepared for up to three color-coded service fixtures, one duplex electrical receptacle and an airflow monitor.

Vapor-proof incandescent lighting illuminates the interior. Explosion-proof models include an explosion-proof incandescent light fixture (bulb not included).

Top of the hood liner is factory-prepared to accommodate two customer-supplied apparatus rods.

Vertical-rising tempered safety glass sash protects the operator while providing excellent visibility.

ETL-listed. Hoods carry the ETL mark signifying that they are certified to UL 3101-1/61010-1 and CAN/CSA C22.2 No. 1010.1.

The curved air foil directs air-flow into the hood to minimize turbulence and ensure fume containment. The foil lifts off for cleaning.

Unassembled models available. Components fit into a carton less than one half its assembled size. The compact container is more economical to ship and store than assembled hood cartons and transports readily to remote locations. Assembly is simple and fast. **Unassembled models are not pre-wired.**

Performance tested to ASHRAE 110-1995.

The right interior wall is factory-prepared to accommodate an accessory cupsink and turret (sold separately).

Durable epoxy-coated 16 gauge steel liner resists chemical degradation.

Pre-wired electrical components. Incandescent lighting and switches are factory-wired to the hood's junction box. **Explosion-proof models are furnished without switches and wiring as these must conform to varying local codes.**

Compact dimensions accommodate tight installations. The 48" height, 53" with built-in blower, makes it ideal for laboratories with lower ceiling heights. Overall depth of 25" makes it adaptable to shallow cabinetry.



* Contact Labconco for specific models.

 Exclusive Feature





Basic™ Laboratory Hoods



Requires
Ductwork



Vapor-proof models feature:

- Pre-wired 100-watt vapor-proof incandescent light, light and blower switches.

Explosion-proof models feature:

- Explosion-proof incandescent light fixture. (Requires installation. Bulb not included.)
- **Furnished without switches and wiring as these must conform to varying local codes.**

Models with blower module feature:

- Belt-driven blower with adjustable sheave.
- Epoxy-coated steel base and housing.
- Corrosion-resistant coated aluminum impeller.

Unassembled models feature:

- Basic 47 Hood carton dimensions: 51" w x 39" d x 14.5" h.
- Basic 70 Hood carton dimensions: 74" w x 39" d x 14.5" h.
- Blower carton dimensions (if applicable): 20" w x 28" d x 16" h.

All models require (not included):

- **Blower.** See page 65 and back pocket.**
- **Ductwork.** See back pocket.
- **Work Surface.** See page 104.
- **Base Cabinet or Stand.** See pages 106-116.

Optional accessories for on-site installation include:

- **Service Fixture Kits.** See page 69.
- **Electrical Duplex Kits.** See page 69.
- **Guardian Airflow Monitor Kits.** See page 69.
- **Cupsink and Turret Kit.** See page 69.
- **Sash Stop Kit.** See page 69.
- **Right Side Finish Panel Kit.** See page 69.

Contact Labconco at **800-821-5525** or **816-333-8811** for blower sizing assistance.

*Contact Labconco for specific models.

** Many models include a blower module.

Heights of switches, electrical receptacle and service fixtures meet requirements of ADA.

All models feature:

- By-pass airflow design.
- Curved air foil that lifts off for cleaning.
- Glacier white, dry powder epoxy-coated, 16 gauge steel exterior and interior.
- Two-piece adjustable baffle.
- 3/16" thick tempered safety glass vertical-rising sash with epoxy-coated aluminum sash handle.
- Removable front panel for access to electrical wiring.
- Factory-prepared right side fixture panel for up to three service fixtures, one duplex electrical receptacle and one airflow monitor (fixtures, receptacle and monitor not included).
- Factory-prepared right interior wall for one cupsink and turret (cupsink and turret not included).

- Factory-prepared top of hood liner for two apparatus rods (rods not included).
- Epoxy-coated steel 10.31" OD exhaust connection.

All models conform to the following regulations and standards:

- SEFA 1-2005
- NFPA 45-2004
- ASTM E84-01
- ASHRAE 110-95
- ANSI Z9.5-2003
- UL 3101-1/61010-1
- CAN/CSA C22.2 No. 1010.1
- CE Conformity Marking (220 volt models)*



Ordering Information & Dimensional Data

Basic™ 47 Laboratory Hoods

Basic 47 Hoods with Blower Module

Capable of overcoming a maximum external static pressure of .25" H₂O at 720 CFM (100 fpm).

Overall dimensions: 47.00" wide x 25.00" deep x 53.00" high (with blower module mounted on top of hood).

Nominal Width	Catalog Number	Electrical Requirements	Incandescent Lamp	Blower Motor Resistance*	Equivalent 10" dia.	Equivalent 12" dia.	Assembly Configuration	Shipping Weight lbs./kg
4 Feet	2247300	115 volts, 60 Hz	Vapor-Proof	1/3 hp	100'	250'	Fully Assembled	370/168
	2247301**	220 volts, 50 Hz	Vapor-Proof	1/2 hp	100'	250'	Fully Assembled	370/168
	2247500	115/230 volts, 60 Hz	EP†	1/3 hp, EP	100'	250'	Fully Assembled	375/170
	2247501**	220 volts, 50 Hz	EP†	1/3 hp, EP	100'	250'	Fully Assembled	375/170
	2246603	115 volts, 60 Hz	Vapor-Proof	1/3 hp	100'	250'	Unassembled	272/123 29/13††
	2246604**	220 volts, 50 Hz	Vapor-Proof	1/2 hp	100'	250'	Unassembled	272/123 29/13††
	2246605	115/230 volts, 60 Hz	EP†	1/3 hp, EP	100'	250'	Unassembled	272/123 41/19††
	2246606**	220 volts, 50 Hz	EP†	1/3 hp, EP	100'	250'	Unassembled	272/123 41/19††

Basic 47 Hoods for use with remote blower

Static pressure loss does not exceed .35" H₂O at 100 fpm (720 CFM). Over all dimensions: 47.00" wide x 25.00" deep x 48.00" high.

Nominal Width	Catalog Number	Electrical Requirements	Incandescent Lamp	Assembly Configuration	Shipping Weight lbs./kg
4 Feet	2247400	115 volts, 60 Hz	Vapor-Proof	Fully Assembled	275/125
	2247401**	220 volts, 50 Hz	Vapor-Proof	Fully Assembled	275/125
	2246600	115 volts, 60 Hz	Vapor-Proof	Unassembled	272/123
	2246601**	110/220 volts, 50 Hz	Vapor-Proof	Unassembled	272/123
	2246602	115/230 volts, 50/60 Hz	EP†	Unassembled	272/123

EP = explosion-proof * Maximum length of straight duct to achieve 100 fpm face velocity ** International electrical configuration † Bulb not included †† Shipping weight of separate blower carton

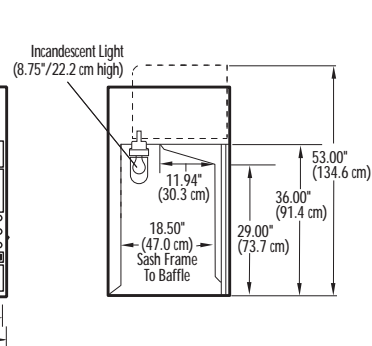
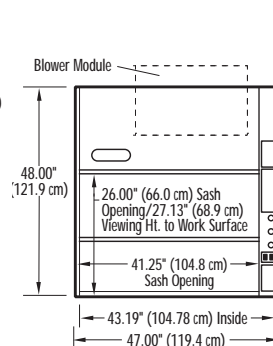
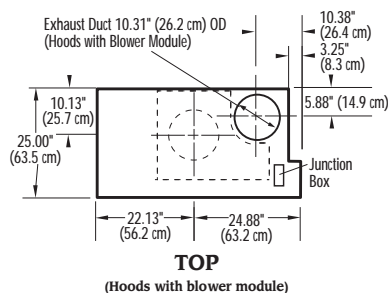
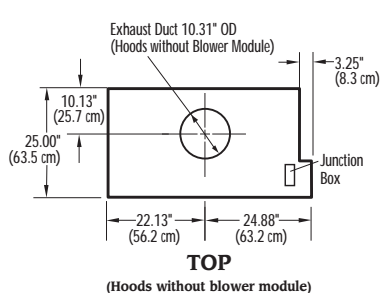

See page 69 for blower module detail.



Ordering Information & Dimensional Data

Basic™ 70 Laboratory Hoods

Basic 70 Hoods with Blower Module

Capable of overcoming a maximum external static pressure of .23" H₂O at 1120 CFM (100 fpm).

Overall dimensions: 70.00" wide x 25.00" deep x 53.00" high (with blower module mounted on top of hood).

Nominal Width	Catalog Number	Electrical Requirements	Incandescent Lamp	Blower Motor Resistance*	Equivalent		Assembly Configuration	Shipping Weight lbs./kg
					10" dia.	12" dia.		
6 Feet	2246300	115 volts, 60 Hz	Vapor-Proof	3/4 hp	45'	100'	Fully Assembled	450/204
	2246301**	220 volts, 50 Hz	Vapor-Proof	3/4 hp	45'	100'	Fully Assembled	450/204
	2246500	115/230 volts, 60 Hz	EP†	3/4 hp, EP	45'	100'	Fully Assembled	455/206
	2246501**	220 volts, 50 Hz	EP†	3/4 hp, EP	45'	100'	Fully Assembled	455/206
	2246703	115 volts, 60 Hz	Vapor-Proof	3/4 hp	45'	100'	Unassembled	426/193 29/13††
	2246704**	220 volts, 50 Hz	Vapor-Proof	3/4 hp	45'	100'	Unassembled	426/193 41/19††
	2246705	115/230 volts, 60 Hz	EP†	3/4 hp, EP	45'	100'	Unassembled	426/193 41/19††
	2246706**	220 volts, 50 Hz	EP†	3/4 hp, EP	45'	100'	Unassembled	426/193 41/19††

Basic 70 Hoods for use with remote blower

Static pressure loss does not exceed .57" H₂O at 100 fpm (1120 CFM). Over all dimensions: 70.00" wide x 25.00" deep x 48.00" high.

Nominal Width	Catalog Number	Electrical Requirements	Incandescent Lamp	Assembly Configuration	Shipping Weight lbs./kg
	2246401**	220 volts, 50 Hz	Vapor-Proof	Fully Assembled	430/195
	2246700	115 volts, 60 Hz	Vapor-Proof	Unassembled	426/193
	2246701**	110/220 volts, 50 Hz	Vapor-Proof	Unassembled	426/193
	2246702	115/230 volts, 50/60 Hz	EP†	Unassembled	426/193

EP = explosion-proof * Maximum length of straight duct to achieve 100 fpm face velocity ** International electrical configuration †Bulb not included †† Shipping weight of separate blower carton

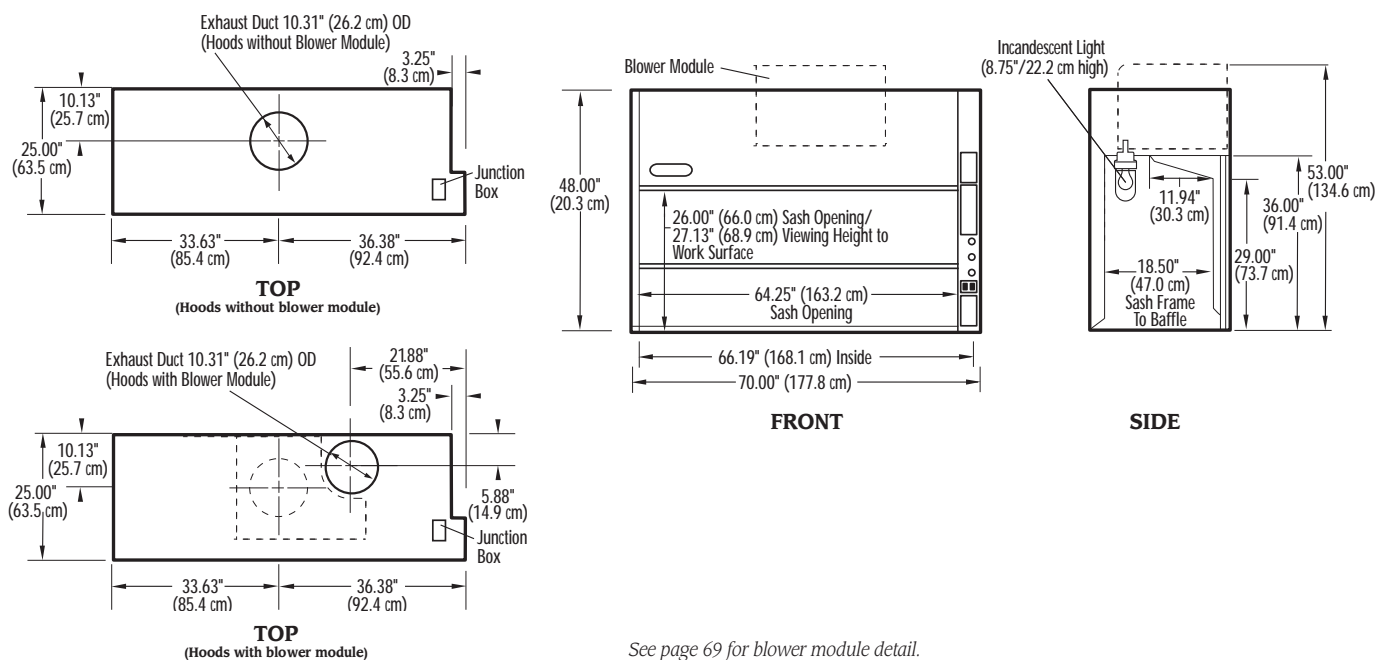

See page 69 for blower module detail.



Accessories

Basic™ Laboratory Hoods



Guardian™ Jr. Airflow Monitor Kits

Audible/visual alarm alerts user to low face velocity. For installation in a factory-prepared cutout on upper portion of right side fixture panel. Shipping weight 6 lbs. (2.7 kg)



Guardian™ Digital Airflow Monitor Kits

An LCD displays average face velocity. Audible/visual alarm alerts user to low or high face velocity. For installation in a factory-prepared cutout on upper portion of right side fixture panel. Shipping weight 6 lbs. (2.7 kg)

Catalog #	Description
9743208	Guardian Jr. Airflow Monitor for 115 volt, 60 Hz operation
9743210**	Guardian Jr. Airflow Monitor for 230 volt, 50 Hz operation

Catalog #	Description
9743207	Guardian Digital Airflow Monitor for 115 volt, 60 Hz operation
9743209**	Guardian Digital Airflow Monitor for 230 volt, 50 Hz operation

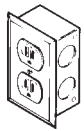

Duplex Electrical Receptacle Kits

Each kit includes duplex electrical receptacle, junction box and receptacle cover plate. For mounting on the lower right side fixture panel. **Electrical wiring is not included.**

Catalog #	Kit	Shipping Wt.
4844400	115 volts, 20 amps AC	4 lbs. (1.8 kg)
4844401	115 volts, 20 amps AC, GFCI	4 lbs. (1.8 kg)



4965901 Sash Stop Kit

The Sash Stop restricts how far the sash may be opened. This small plastic device may be easily installed on the left side of Basic Hoods to restrict sash opening height. Shipping weight 0.5 lb. (0.2 kg)



4852500 Cupsink and Turret Kit

Polypropylene cupsink, 3" x 6", and chrome turret mount on right side wall. **Plumbing pipe is not included.** Shipping weight 0.5 lb. (0.2 kg)

4878600 Right Side Finish Panel Kit

Includes a glacier white epoxy-coated steel panel to provide a finished appearance to the right side of the hood. The panel hides the exposed plumbing when service fixtures are installed. Not for use with 4852500 Cupsink and Turret. Shipping weight 20 lbs. (9 kg)

** International electrical configuration

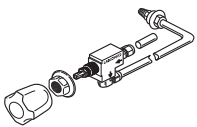

Standard Service Fixture Kits

Each kit includes one remotely-controlled service fixture with 0.25" diameter valve and tubing, color-coded fixture knob and color-coded hose connector. For mounting on the right side fixture panel. Shipping weight 4 lbs. (1.8 kg)

Catalog #	Kit	Tubing	Valve	Knob/Connector Color	Maximum Flow Rate	Maximum Working Pressure*
2832600	Cold Water (CW)	Copper	Brass	Green	3.5 GPM (13.2 LPM)	40 psi
2832601	Hot Water (HW)	Copper	Brass	Red	3.5 GPM (13.2 LPM)	40 psi
2832602	Deionized/ Distilled Water (DI)	Stainless Steel	Nickel-Plated/ Stainless Steel	White	3.5 GPM (13.2 LPM)	40 psi
2832603	Vacuum (VAC)	Copper	Brass	Yellow	8.6 CFM	14.7 psi
2832604	Air (AIR)	Copper	Brass	Orange	23.7 CFM	40 psi
2832605	Gas (GAS)	Brass	Brass	Blue	29.0 CFM (441 BTU/sec)	40 psi
2832606	Nitrogen (NIT)	Copper	Brass	Brown	24.1 CFM	40 psi
2832607	Argon (ARG)	Copper	Brass	Gray	20.2 CFM	40 psi
2832608	Steam (STM)	Copper	Brass	Black	0.5 LBM/min	40 psi

GPM = gallons per minute LPM = liters per minute CFM = cubic feet per minute BTU/sec = British thermal unit per second LBM/min = pounds mass per minute
 * Maximum allowable pressure is 200 psi with a working pressure of 40 psi.

Blower Module Detail

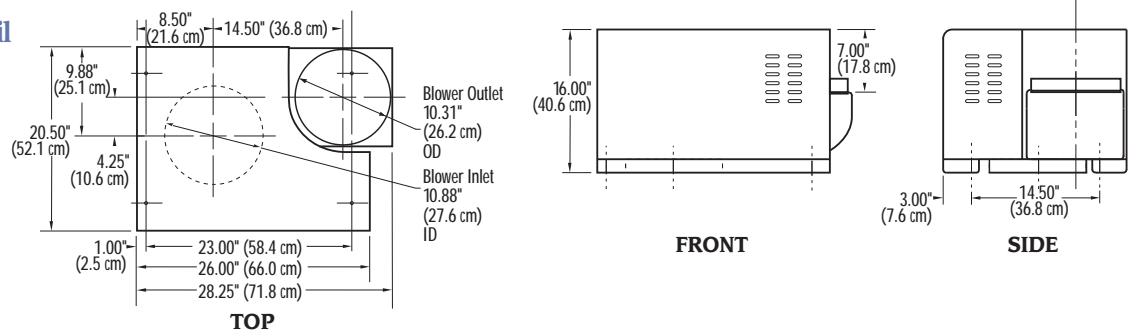



Fiberglass 30 Laboratory Hoods



Fiberglass 30 Laboratory Hood 3030002 is shown with Flat Solid Epoxy Work Surface 4882806 and Protector Standard Storage Cabinet 9900200. Remote blower, ductwork, work surface and base cabinet must be ordered separately.

Compact Fiberglass 30 Laboratory Hoods are designed for research, educational and clinical applications requiring small working space and efficient fume removal. Like the Protector Premier line, these hoods feature a corrosion-resistant, one-piece molded fiberglass liner.

All models feature:

- By-pass airflow design.
- Durable glacier white, dry powder epoxy-coated steel exterior.
- One-piece molded fiberglass interior and pre-set baffle with flame spread index less than 25 per ASTM E-84.
- 3/16" thick tempered safety glass vertical-rising sash with epoxy-coated aluminum handle.
- Pivoting air foil.
- Right side fixture panel factory-prepared to accept up to three service fixtures, one electrical duplex and one airflow monitor (kits are sold separately).
- 6.69" ID fiberglass exhaust connection.

All models conform to the following regulations and standards:

- SEFA 1-2005
- NFPA 45-2004
- ASTM E84-01
- ASHRAE 110-95
- ANSI Z9.5-2003
- UL 3101-1/61010-1
- CAN/CSA C22.2 No. 1010.1
- UL 1805
- CE Conformity Marking (230 volt models)*

Models 3030000 and 3030001 feature:

- Built-in corrosion-resistant, direct drive exhaust blower capable of overcoming a maximum external static pressure of 0.12" H₂O at 310 CFM (100 fpm).
- Pre-wired 100 watt, vapor-proof incandescent lighting, light and blower switches.

Models 3030002 and 3030003:

- Designed for use with remote blower (not included).

- Static pressure loss does not exceed 0.14" H₂O at 100 fpm (310 CFM).
- Pre-wired 100 watt, vapor-proof incandescent lamp, light and blower switches.

Models 3030004 and 3030005 feature:

- Built-in corrosion-resistant, explosion-proof, direct drive exhaust blower capable of overcoming a maximum external static pressure of 0.12" H₂O at 310 CFM (100 fpm).
- **Furnished without light, switches or wiring. Wiring must conform to local codes.** (Explosion-proof Light Fixture Kit is available. See page 71.)

All models require (not included):

- **Ductwork.** See back pocket.
- **Work Surface.** See page 104.
- **Base Cabinet or Stand.** See pages 106-116.

Optional accessories for on-site installation include:

- **Service Fixture Kits.** See page 71.
- **Electrical Duplex Kits.** See page 71.
- **Guardian Airflow Monitor Kits.** See page 71.
- **Explosion-Proof Light Fixture Kit.** See page 71.

Contact Labconco at **800-821-5525** or **816-333-8811** for blower sizing assistance.

*Contact Labconco for specific models.

Ordering Information

Catalog Number	Built-in Blower	Equivalent Resistance**		Electrical Requirements	Vapor-Proof Lamp	Dimensions (w x d x h)	Shipping Weight lbs./kg
		6" dia.	8" dia.				
3030000	1/10 HP, Std.	20'	80'	115 volts, 60 Hz	100 watt	30.00" x 30.16" x 48.00"	230/104
3030001†	1/3 HP, Std.	20'	80'	230 volts, 50 Hz	100 watt	30.00" x 30.16" x 52.00"	230/104
3030002	None	—	—	115 volts, 60 Hz	100 watt	30.00" x 30.16" x 48.00"	210/95
3030003†	None	—	—	230 volts, 50 Hz	100 watt	30.00" x 30.16" x 48.00"	210/95
3030004	1/4 HP, EP	20'	80'	115 volts, 60 Hz	None	30.00" x 30.16" x 54.00"	240/109
3030005†	1/3 HP, EP	20'	80'	230 volts, 50 Hz	None	30.00" x 30.16" x 54.00"	240/109

EP = Explosion-proof ** Maxim um length of straight duct to achieve 100 fpm face velocity † International electrical configuration



Accessories & Dimensional Data

Fiberglass 30 Laboratory Hoods

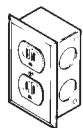

Duplex Electrical Receptacle Kits

Each kit includes duplex electrical receptacle, wiring, junction box and receptacle cover plate. For mounting on the lower right side fixture panel.

Catalog #	Kit	Shipping Wt.
2834800	115 volts, 20 amps AC	4 lbs. (1.8 kg)
2834801	115 volts, 20 amps AC, GFCI	4 lbs. (1.8 kg)

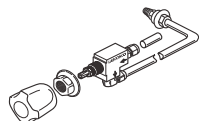

Standard Service Fixture Kits

Each kit includes one remotely-controlled service fixture with 0.25" diameter valve and tubing, color-coded fixture knob and color-coded hose connector. For mounting on the right side fixture panel. Shipping weight 4 lbs. (1.8 kg)

Catalog #	Kit	Tubing	Valve	Knob/Connector Color
2832600	Cold Water (CW)	Copper	Brass	Green
2832601	Hot Water (HW)	Copper	Brass	Red
2832602	Deionized/ Distilled Water (DI)	Stainless Steel	Nickel-Plated/ Stainless Steel	White
2832603	Vacuum (VAC)	Copper	Brass	Yellow
2832604	Air (AIR)	Copper	Brass	Orange
2832605	Gas (GAS)	Brass	Brass	Blue
2832606	Nitrogen (NIT)	Copper	Brass	Brown
2832607	Argon (ARG)	Copper	Brass	Gray
2832608	Steam (STM)	Copper	Brass	Black

See maximum flow rates and working pressures on page 69.



Guardian™ Digital Airflow Monitor Kits

An LCD displays average face velocity. Audible/visual alarm alerts user to low or high face velocity. For installation in a factory-prepared cutout on upper portion of right side fixture panel. Shipping weight 6 lbs. (2.7 kg)

Catalog #	Description
9743201	Guardian Digital Airflow Monitor for 115 volt, 60 Hz operation
9743205*	Guardian Digital Airflow Monitor for 230 volt, 50 Hz operation



Guardian™ 500 Airflow Monitor Field Installation Kits

Audible/visual alarm alerts user to low face velocity. For installation in a factory-prepared cutout on upper portion of right side fixture panel. Shipping weight 6 lbs. (2.7 kg)

Catalog #	Description
9743213	Guardian Jr. Airflow Monitor for 115 volt, 60 Hz operation
9743214*	Guardian Jr. Airflow Monitor for 230 volt, 50 Hz operation

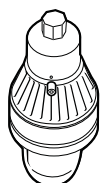

4892900 Explosion-Proof Light Fixture Kit

For mounting on Fiberglass 30 Hood 3030004 or 3030005. Includes explosion-proof incandescent light fixture, mounting hardware and instructions. 13" h x 7" diameter. **Bulb and electrical wiring are not included.** Shipping weight 11 lbs. (5 kg)

* International electrical configuration

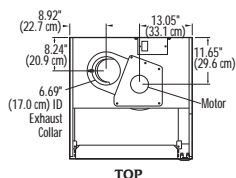

TOP

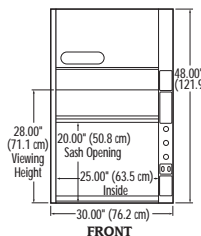

FRONT

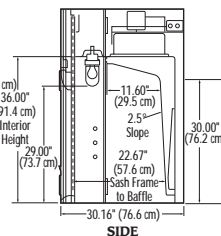

SIDE

3030000
(with Built-in Blower)

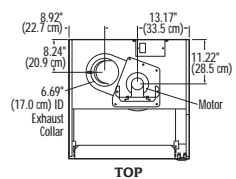

TOP

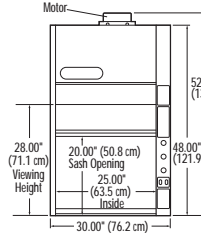

FRONT

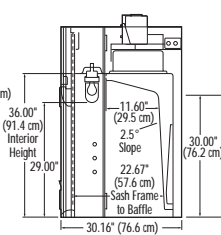

SIDE

3030001
(with Built-in Blower)

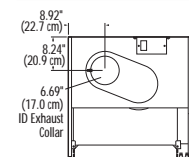

TOP

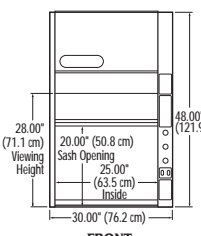

FRONT

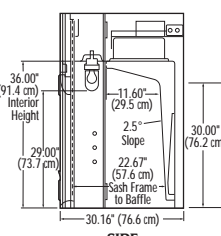

SIDE

3030002 and 3030003
(for use with Remote Blower)

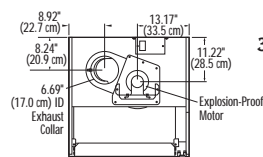

TOP

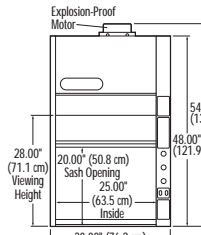

FRONT

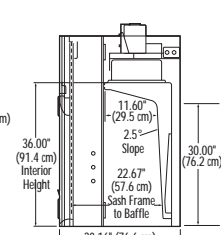

SIDE

3030004 and 3030005
(with Built-in
Explosion-Proof Blower)



Fume Adsorbers

At right: Fume Adsorber 3955200 is shown with Flat Solid Epoxy Work Surface 4882803 and Protector Solvent Storage Cabinet 9902000. Work surface and base cabinet must be ordered separately. *Below:* Fume Adsorber-2 3955400 is shown with Flat Solid Epoxy Work Surface 4882804 and Protector Standard Storage Cabinets 9904500 and 9904200. Work surface and base cabinets must be ordered separately.



Fume Adsorbers are designed for light duty applications involving organic solvents, formaldehyde, ammonia or low molecular weight amines. Fume Adsorbers use carbon filtration to trap vapors so that safe, filtered air is returned to the laboratory. No outside ducting is required. These portable, low profile enclosures fit easily on countertops with overhanging cabinets and are available in two widths.

Each Fume Adsorber includes one carbon filter (each Fume Adsorber-2 includes two) that adsorbs vapors from organic solvents, formaldehyde or ammonia, depending on the filter.

Whether or not the Fume Adsorber would be appropriate for your application requires consideration of factors such as the time-weighted exposure limits of your materials. Using Labconco's exclusive chemical assessment service, our technical specialists can help you determine if it is the right product for your application and estimate filter life. Complete the Chemical Usage Assessment Form available at www.labconco.com/chemical_usage.html or call **800-821-5525**.

All models feature:

- Built-in motorized impeller to provide face velocity up to 35 fpm (Fume Adsorber-2 models include two impellers.)
- Glacier white, dry powder, epoxy-coated steel housing with perforated baffle for uniform airflow.
- Clear, one-piece, 3/8" thick, shatter-resistant acrylic canopy.
- Quiet operation at 58-63 dBA.

- Pre-wired with rear-mounted auxiliary electrical receptacle and top-mounted blower switch with circuit breaker.
- Rear-mounted air sampling port.
- Exterior dimensions: 15.4" h x 23.4" d.
- Interior dimensions: 13.5" h x 14.5" d.
- Available in two widths: 30.0" and 60.0".

All models conform to the following regulations and standards:

- UL 3101-1/61010-1 (115 volt models)
- CAN/CSA C22.2 No. 1010.1 (115 volt models)
- CE Conformity Marking (230 volt models)

Fume Adsorber Model 3955200 features one each and Fume Adsorber-2 Model 3955400 features two each:

- Replaceable 6 pound Type AC activated carbon filter, 26.0" w x 9.0" h, to adsorb organic vapors such as xylene and toluene. Adsorbs up to one third its weight.

Fume Adsorber Model 3955201 features one each and Fume Adsorber-2 Model 3955401 features two each:

- Replaceable 7.5 pound impregnated carbon filter, 26.0" w x 9.0" h, treated to adsorb formaldehyde. Adsorption weight 10% (0.75 lb).

Fume Adsorber Model 3955202 features one each and Fume Adsorber-2 Model 3955402 features two each:

- Replaceable 8.8 pound impregnated carbon filter, 26.0" w x 9.0" h, treated to adsorb ammonia and low molecular weight amine vapors. Adsorption weight 10% (0.88 lb).

Fume Adsorber Models 3955200, 3955201 and 3955202 and Fume Adsorber-2 Models 3955400, 3955401 and 3955402 feature:

- Operation on 115 volts, 60 Hz, 2 amps.
- 6.5' IEC three-wire cord with plug.

Fume Adsorber Models 3955220, 3955221 and 3955222 and Fume Adsorber-2 Models 3955420, 3955421 and 3955422 feature:

- Operation on 230 volts, 50 Hz, 1 amp.
- 9' IEC three-wire cord. **An electrical plug is required.**

If not placed on existing casework, all models require:

- **Flat Work Surface.** See page 104.
- **Base Stand or Cabinet.** See pages 106-116.





Ordering Information & Dimensional Data

Fume Adsorbers

Catalog #	Description	Shipping Wt. lbs./kg
3955200	Fume Adsorber with Activated Carbon Filter for Organic Vapors. 30.0" exterior width, 29.25" interior width, for 115 volt, 60 Hz, 2 amp operation.	67/30
3955201	Fume Adsorber with Impregnated Carbon Filter for Formaldehyde Vapors. 30.0" exterior width, 29.25" interior width, for 115 volt, 60 Hz, 2 amp operation.	69/31
3955202	Fume Adsorber with Impregnated Carbon Filter for Ammonia Vapors. 30.0" exterior width, 29.25" interior width, for 115 volt, 60 Hz, 2 amp operation.	71/32
3955220*	Fume Adsorber with Activated Carbon Filter for Organic Vapors. 30.0" exterior width, 29.25" interior width, for 230 volt, 50 Hz, 1 amp operation.	67/30
3955221*	Fume Adsorber with Impregnated Carbon Filter for Formaldehyde Vapors. 30.0" exterior width, 29.25" interior width, for 230 volt, 50 Hz, 1 amp operation.	69/31
3955222*	Fume Adsorber with Impregnated Carbon Filter for Ammonia Vapors. 30.0" exterior width, 29.25" interior width, for 230 volt, 50 Hz, 1 amp operation.	71/32
3955400	Fume Adsorber-2 with Activated Carbon Filters for Organic Vapors. 60.0" exterior width, 59.25" interior width, for 115 volt, 60 Hz, 2 amp operation.	135/61
3955401	Fume Adsorber-2 with Impregnated Carbon Filters for Formaldehyde Vapors. 60.0" exterior width, 59.25" interior width, for 115 volt, 60 Hz, 2 amp operation.	137/62
3955402	Fume Adsorber-2 with Impregnated Carbon Filters for Ammonia Vapors. 60.0" exterior width, 59.25" interior width, for 115 volt, 60 Hz, 2 amp operation.	139/63
3955420*	Fume Adsorber-2 with Activated Carbon Filters for Organic Vapors. 60.0" exterior width, 59.25" interior width, for 230 volt, 50 Hz, 2 amp operation.	135/61
3955421*	Fume Adsorber-2 with Impregnated Carbon Filters for Formaldehyde Vapors. 60.0" exterior width, 59.25" interior width, for 230 volt, 50 Hz, 2 amp operation.	137/62
3955422*	Fume Adsorber-2 with Impregnated Carbon Filters for Ammonia Vapors. 60.0" exterior width, 59.25" interior width, for 230 volt, 50 Hz, 2 amp operation.	139/63
6961300	Replacement Activated Carbon Filter for use with organic vapors. 6 pounds of activated carbon. Adsorbs up to one third of its weight. Adsorption capacity dependent on chemical properties.** One each. <i>Fume Adsorber Models 3955200 and 3955220 include one filter; Fume Adsorber -2 Models 3955400 and 3955420 include two filters.</i>	9/4
6961301	Replacement Formaldehyde Carbon Filter for use with formaldehyde and gluteraldehyde. 7.5 pounds of impregnated carbon. Adsorption weight 10% (0.75 lb.). Adsorption volume 850 ml of 37% formalin. One each. <i>Fume Adsorber Models 3955201 and 3955221 include one filter; Fume Adsorber -2 Models 3955401 and 3955421 include two filters.</i>	11/5
6961302	Replacement Ammonia Carbon Filter for use with ammonia and low molecular weight amines. 8.8 pounds of impregnated carbon. Adsorption weight 10% (0.88 lbs.). Adsorption volume 800 ml of 50% ammonia. One each. <i>Fume Adsorber Models 3955202 and 3955222 include one filter; Fume Adsorber -2 Models 3955402 and 3955422 include two filters.</i>	13/6
6924900	Syringe Kit for carbon saturation detection. Contaminant detector tubes are not included (See Detector Tubes below or contact your safety supply distributor).	1/0.5
6926000	Formaldehyde Detector Tubes , package of 3.	0.5/0.2
6925700	Ammonia Detector Tubes , package of 3.	0.5/0.2

* International electrical configuration

**Complete the Chemical Usage Assessment Form at www.labconco.com/chemical_usage/html or call 800-821-5525 or 816-333-8811.



4' Paramount Ductless Enclosure 6963401 is shown with Work Surface 3909902 and Protector Standard Base Cabinet 9900000.

***Inset:** 3' Paramount Ductless Enclosure 6963302 with the optional glass baffle provides 360 ° visibility, well suited for classroom demonstrations. It is shown on Work Surface 3909901 and Telescoping Base Stand with casters 3746711.*



Paramount® Ductless Enclosures

Features & Benefits

Paramount Ductless Enclosures are self-contained while allowing for safe handling of organic, formaldehyde, acid gas, sulfur compounds or ammonia chemical fumes and vapors as well as particulates.

Air inside the enclosure passes through carbon filters and, in some cases additional HEPA filters, before being safely exhausted back into the laboratory. Two filter types may be

stacked for mixed chemical or combination gaseous/particulate applications. **No outside ducting is required.**

Two helpful tools are available at www.labconco.com. The online **Chemical Guide for Filtered Enclosures** will help you determine if the chemicals you are using are right for a Paramount. For technical assistance from a Labconco Specialist, submit the **Chemical Usage Assessment Form**.



Convenient, front-accessible filter replacement. The gas spring-assisted clamping mechanism opens effortlessly and applies uniform pressure across the top surface of the filters for leak-proof, one-step filter replacement.

Upper Containment Sash Foil directs contaminants away from the user's breathing zone.

Patented* Clean-Sweep™ Air Foil allows air to sweep the work surface to maximize containment.

Side-entry air foils allow air to sweep interior surfaces to enhance containment.

Optional clear safety glass baffle provides 360° visibility for teaching demonstrations. The baffle pivots down for cleaning.

Safety-First™ Vapor Sensor accurately detects filter breakthrough. Primary and secondary backup sensors provide redundant monitoring and detection of organic solvents, smoke particulates, ammonia gases, formaldehyde gases and hydrosulfide gases. The sensor also provides an early warning when 5-10% of filter life is remaining to allow time for the user to change filters.

Filter efficiency performance independently verified by University of Kansas.¹

Exclusive Feature

¹U.S. Patent No. 6,461,233

²U.S. Patent No. D 538,941

³Contact Labconco for more information.

Smart-Flow™ System adjusts the motor speed automatically for filter pressure drop, barometric pressure and room temperature, and maintains constant airflow at the calibrated value.

Accommodates seven filter types to cover a wide variety of needs. Filters are stackable to handle mixed chemical applications.

Quieter, cooler and more energy-efficient ECM impeller is 95% efficient, generates less heat for more comfortable working conditions, and operates from 52 to 62 dBA at 80 fpm depending on the model.

Fluorescent light illuminates the interior. Timer may be set for a specific time period for energy savings as well as a safeguard for light-sensitive materials.

Patented* rear baffle with zones of perforations promotes non-turbulent horizontal laminar flow. The baffle pivots down for cleaning.

Ergonomic angled sash and patented sloped front** allow closer view of the work area, reduce glare and provide a more comfortable operating position. Hinged sash pivots upward for loading and has a wiping seal to contain contaminants. Taller models incorporate an external gas-assist lift.

Upper Dilution Air Supply sweeps clean air to the back of the sash to keep contaminants away from the operator.



ETL-listed. Hoods carry the ETL mark signifying that they are certified to UL 3101-1/61010-1 and CAN/CSA C22.2 No. 1010.1.

CE mark. All 230 volt, 50 Hz models conform to the CE (European Community) requirements for electrical safety and electromagnetic compatibility.



Large LCD displays face velocity and filter status, and touchpad control of enclosure operation. Three screens alternate on the display: filter types and status, estimated filter life for the bottom filter(s), and estimated filter life for the top filter(s). Filter life and check timers trigger audible/visual alert messages after the specified number of hours has passed.











Paramount® Ductless Enclosures



6' Paramount Ductless Enclosure 6963601 is shown on Work Surface 3975602 and Hydraulic Lift Base Stand 3780402 with Caster Kit 3784000. Work Surface, Base Stand, Caster Kit and filters are sold separately.

All models feature:

-  Clean-Sweep™ air foil*
-  Upper dilution air supply.
-  Upper containment sash foil.
-  Zone-perforated rear baffle that pivots down for cleaning.*
 - Side-entry air foils.
-  Safety-First™ vapor sensor with early audible warning for accurate detection of filter breakthrough.
-  ECM impeller with timer that operates at 52-62 dBA at 80 feet per minute. 6' Paramounts have two impellers.
-  Smart-Flow™ system to automatically adjust motor speed for filter pressure drop, barometric pressure and room temperature.

-  LCD message center, 3" x 1.5", to provide continuous status reports for each filter, airflow speed, and filter saturation and low airflow alarm messages.
 - Filter life and check timers with audible/LCD visual elapsed time alerts.
 - Digital touchpad controls.
-  Dry powder epoxy-coated aluminum frame and steel rear plenum and baffle. No plastic-to-plastic bonding is used.
 - Pre-wired fluorescent lamp with timer.
 - Electronic security lock (optional activation) that requires password to change operating parameters.
 - 1/4" thick tempered safety glass front sash and sides.
 - Ergonomic angled and hinged pivoting sash with wiping seal and patented** sloped front.

- Models with 9.4" sash opening height have 16.5" locking height and 19.0" maximum loading height. Models with 12.0" sash opening height and 32.0" interior height have 25.8" locking height and 28.3" maximum loading height. Models with 12.0" sash opening height and 35.0" interior height have 28.8" locking height and 31.3" maximum loading height.

-  Filter efficiency performance independently verified by University of Kansas.†
- Particulate containment data independently confirmed by SafeBridge Consultants, Inc.
- 8.2' power cord and plug.

All models conform to the following regulations and standards:

- SEFA 1-2006
- ASHRAE 110-95
- ANSI Z9.5-2003
- UL 3101-1/61010-1
- CAN/CSA C22.2 No. 1010.1
- CE Conformity Marking (230 volt models)

Models with glass baffle feature:

- 1/4" thick tempered safety glass baffle without perforations that pivots down for cleaning.

All models require (not included):

- **Work Surface and Base.** See pages 80-81 and 106-116.
- **Filters.** See page 79.

Optional accessories:

- **Canopy Exhaust Transition.** See page 81.
- **Sash Closures.** See page 81.
- **Utility Shelves, Bottle Holder and Tissue Holder.** See page 121.

Contact Labconco at **800-821-5525** or **816-333-8811** for application assistance.



 Exclusive Feature * U.S. Patent No. 6,461,233 ** U.S. Patent No. D 538,941 †Contact Labconco for more information.



Ordering Information

Paramount® Ductless Enclosures

Nominal Width	Catalog (Description)	Electrical Requirements	Overall W x D x H	Interior Working Height	Sash Opening Working Height	Sash Opening Loading Height*	Face Velocity (fpm)	Airflow Exhaust Volume (CFM)	Noise Pressure (dbA)	Shipping Weight (lbs./kg)
2'	6963200 (Std.)	115 volts, 50/60 Hz	24.0" x 29.0" x 43.7"	22.7"	9.4"	19.0"	60	85	50	175/79
							80	115	54	
							100	145	59	
2'	6963220** (Std.)	230 volts, 50/60 Hz	24.0" x 29.0" x 43.7"	22.7"	9.4"	19.0"	60	85	50	175/79
							80	115	54	
							100	145	59	
3'	6963300 (Std.)	115 volts, 50/60 Hz	36.0" x 29.0" x 43.7"	22.7"	9.4"	19.0"	60	130	46	225/102
							80	175	52	
							100	220	56	
3'	6963301 (Tall)	115 volts, 50/60 Hz	36.0" x 29.0" x 53.0"	32.0"	12.0"	28.3"	60	170	52	255/116
							80	230	57	
							100	285	62	
3'	6963302† (Tall & Clear)	115 volts, 50/60 Hz	36.0" x 29.0" x 53.0"	32.0"	12.0"	28.3"	60	170	52	275/125
							80	230	57	
							100	285	62	
3'	6963320** (Std.)	230 volts, 50/60 Hz	36.0" x 29.0" x 43.7"	22.7"	9.4"	19.0"	60	130	46	225/102
							80	175	52	
							100	220	56	
3'	6963321** (Tall)	230 volts, 50/60 Hz	36.0" x 29.0" x 53.0"	32.0"	12.0"	28.3"	60	170	52	255/116
							80	230	57	
							100	285	62	
3'	6963322*** (Tall & Clear)	230 volts, 50/60 Hz	36.0" x 29.0" x 53.0"	32.0"	12.0"	28.3"	60	170	52	275/125
							80	230	57	
							100	285	62	
4'	6963400 (Std.)	115 volts, 50/60 Hz	48.0" x 29.0" x 43.7"	22.7"	9.4"	19.0"	60	175	53	275/125
							80	235	57	
							100	295	62	
4'	6963401 (Tall)	115 volts, 50/60 Hz	48.0" x 29.0" x 53.0"	32.0"	12.0"	28.3"	60	230	57	315/143
							80	305	62	
							100	380	67	
4'	6963402† (Tall & Clear)	115 volts, 50/60 Hz	48.0" x 29.0" x 53.0"	32.0"	12.0"	28.3"	60	230	57	345/156
							80	305	62	
							100	380	67	
4'	6963403 (Tall & Deep)	115 volts, 50/60 Hz	48.0" x 35.5" x 56.0"	35.0"	12.0"	31.3"	60	230	59	540/245
							80	305	62	
							100	380	67	
4'	6963420** (Std.)	230 volts, 50/60 Hz	48.0" x 29.0" x 43.7"	22.7"	9.4"	19.0"	60	175	53	275/125
							80	235	57	
							100	295	62	
4'	6963421** (Tall)	230 volts, 50/60 Hz	48.0" x 29.0" x 53.0"	32.0"	12.0"	28.3"	60	230	57	315/143
							80	305	62	
							100	380	67	
4'	6963422*** (Tall & Clear)	230 volts, 50/60 Hz	48.0" x 29.0" x 53.0"	32.0"	12.0"	28.3"	60	230	57	345/156
							80	305	62	
							100	380	67	
4'	6963423** (Tall & Deep)	230 volts, 50/60 Hz	48.0" x 35.5" x 56.0"	35.0"	12.0"	31.3"	60	230	59	540/245
							80	305	62	
							100	380	67	
5'	6963501 (Tall)	115 volts, 50/60 Hz	60.0" x 29.0" x 53.0"	32.0"	9.4"	28.3"	60	220	57	395/179
							80	295	62	
							100	370	67	
5'	6963503 (Tall & Deep)	115 volts, 50/60 Hz	60.0" x 35.5" x 56.0"	35.0"	9.4"	31.3"	60	220	57	565/256
							80	295	62	
							100	370	67	
5'	6963521** (Tall)	230 volts, 50/60 Hz	60.0" x 29.0" x 53.0"	32.0"	9.4"	28.3"	60	220	57	395/179
							80	295	62	
							100	370	67	
5'	6963523** (Tall & Deep)	230 volts, 50/60 Hz	60.0" x 35.5" x 56.0"	35.0"	9.4"	31.3"	60	220	57	565/256
							80	295	62	
							100	370	67	
6'	6963601 (Tall)	115 volts, 50/60 Hz	72.0" x 29.0" x 53.0"	32.0"	12.0"	28.3"	60	350	57	475/215
							80	465	61	
							100	580	66	
6'	6963603 (Tall & Deep)	115 volts, 50/60 Hz	72.0" x 35.5" x 56.0"	35.0"	12.0"	31.3"	60	350	57	680/308
							80	465	61	
							100	580	66	
6'	6963621** (Tall)	230 volts, 50/60 Hz	72.0" x 29.0" x 53.0"	32.0"	12.0"	28.3"	60	350	57	475/215
							80	465	61	
							100	580	66	
6'	6963623** (Tall & Deep)	230 volts, 50/60 Hz	72.0" x 35.5" x 56.0"	35.0"	12.0"	31.3"	60	350	57	680/308
							80	465	61	
							100	580	66	

*Locking height is 2.5" (6.4 cm) less than the loading height. ** International electrical configuration †360° visibility with glass rear wall and baffle
 Contact Labconco Corporation for ordering information on 8", 10" and 12" models.



Dimensional Data

Paramount® Ductless Enclosures

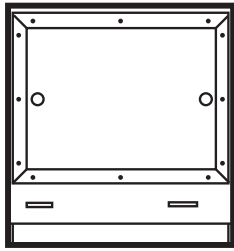

TOP

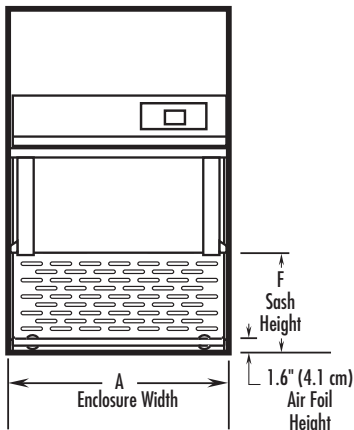

FRONT

Catalog Numbers	Paramount Description	Overall Width A	Interior Height B	Interior Depth C	Exterior Depth D	Exterior Height E	Sash Opening F
6963200 6963220	2' Standard	24.0" (61.0 cm)	22.7" (57.7 cm)	23.4" (59.4 cm)	29.0" (73.7 cm)	43.7" (111.0 cm)	9.4" (23.9 cm)
6963300 6963320	3' Standard	36.0" (91.4 cm)	22.7" (57.7 cm)	23.4" (59.4 cm)	29.0" (73.7 cm)	43.7" (111.0 cm)	9.4" (23.9 cm)
6963301 6963321	3' Tall	36.0" (91.4 cm)	32.0" (81.3 cm)	23.4" (59.4 cm)	29.0" (73.7 cm)	53.0" (134.6 cm)	12.0" (30.5 cm)
6963302 6963322	3' Tall with Clear Baffle	36.0" (91.4 cm)	32.0" (81.3 cm)	23.4" (59.4 cm)	29.0" (73.7 cm)	53.0" (134.6 cm)	12.0" (30.5 cm)
6963400 6963420	4' Standard	48.0" (121.9 cm)	22.7" (57.7 cm)	23.4" (59.4 cm)	29.0" (73.7 cm)	43.7" (111.0 cm)	9.4" (23.9 cm)
6963401 6963421	4' Tall	48.0" (121.9 cm)	32.0" (81.3 cm)	23.4" (59.4 cm)	29.0" (73.7 cm)	53.0" (134.6 cm)	12.0" (30.5 cm)
6963402 6963422	4' Tall with Clear Baffle	48.0" (121.9 cm)	32.0" (81.3 cm)	23.4" (59.4 cm)	29.0" (73.7 cm)	53.0" (134.6 cm)	12.0" (30.5 cm)
6963403 6963423	4' Tall & Deep	48.0" (121.9 cm)	35.0" (88.9 cm)	30.0" (76.2 cm)	35.5" (90.2 cm)	56.0" (142.2 cm)	12.0" (30.5 cm)
6963501 6963521	5' Tall	60.0" (152.4 cm)	32.0" (81.3 cm)	23.4" (59.4 cm)	29.0" (73.7 cm)	53.0" (134.6 cm)	9.4" (23.9 cm)
6963503 6963523	5' Tall & Deep	60.0" (152.4 cm)	35.0" (88.9 cm)	30.0" (76.2 cm)	35.5" (90.2 cm)	56.0" (142.2 cm)	9.4" (23.9 cm)
6963601 6963621	6' Tall	72.0" (182.9 cm)	32.0" (81.3 cm)	23.4" (59.4 cm)	29.0" (73.7 cm)	53.0" (134.6 cm)	12.0" (30.5 cm)
6963603 6963623	6' Tall & Deep	72.0" (182.9 cm)	35.0" (88.9 cm)	30.0" (76.2 cm)	35.5" (90.2 cm)	56.0" (142.2 cm)	12.0" (30.5 cm)

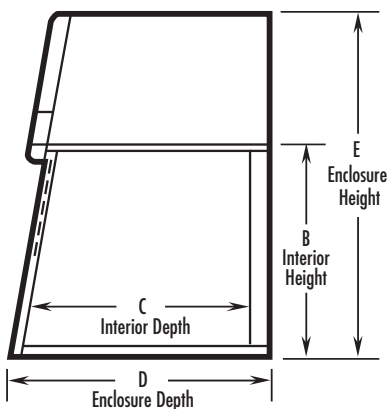

SIDE

(Standard Models)

**6963200,
6963220, 6963300,
6963320, 6963400,
6963420**

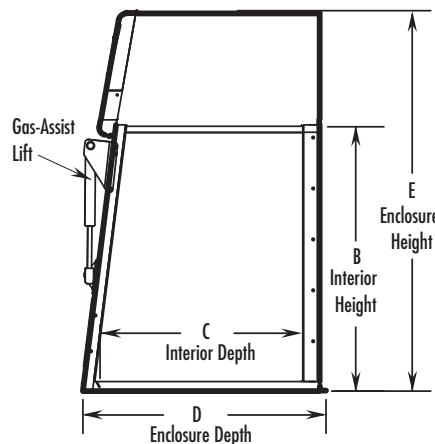

SIDE

(Tall Models)

**6963301, 6963302,
6963321, 6963322, 6963401,
6963402, 6963421, 6963422,
6963501, 6963521, 6963601,
6963621**

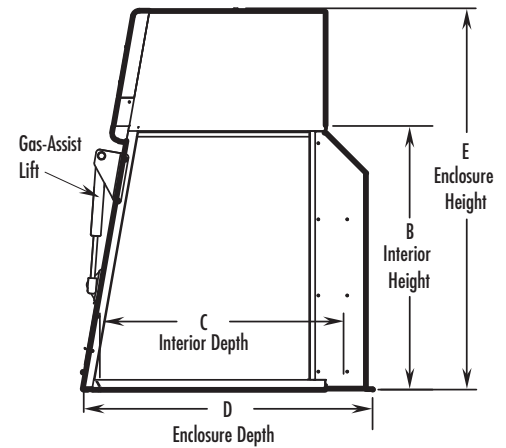

SIDE

(Tall & Deep Models)

**6963403,
6963423, 6963503,
6963523, 6963603,
6963623**



Filters & Accessories

Paramount® Ductless Enclosures



Below is an Application Matrix that provides examples of appropriate uses for Paramount Carbon and HEPA Filters. Whether or not any ductless enclosure is appropriate for your application requires consideration of factors such as the time-weighted exposure limits of your materials. Using Labconco's exclusive chemical assessment program, our technical specialists can help you determine if the Paramount Ductless Enclosure is the right ventilation product for your application and, if so, estimate filter life. To begin the process, please complete the Chemical Usage Assessment Form available online at www.labconco.com. To discuss your application with a technical specialist, please call 800-821-5525 or 816-333-8811.

Filters are available in seven different types and any two types of filters may be stacked to handle mixed chemical applications. An online **Chemical Guide**, available at www.labconco.com, allows you to search individual chemicals to determine their suitability for use with the Paramount. The Chemical Guide provides the appropriate Paramount Filter for each chemical.

Application Matrix

Filter Type	Organic	Acid-Sulfur	Ammonia	Formaldehyde	Radioisotope	Mixed Bed	HEPA	HEPA + Carbon*
Acid pouring and mixing		●				●		
Asbestos handling							●	
Cleanroom/critical environment								●
Combination dry and liquid chemicals								●
Endoscopy instrument cleaning				●				
Fertilizer research			●					
Histology/cytology tissue staining, coverslipping	●					●		
Hormone research							●	●
Iodine isotope handling					●			
Non-biohazardous microbiological samples with trace chemicals**								●
Particulates in conjunction with chemical agents								●
Pathology/tissue grossing				●		●		
Pollen handling							●	
Science education						●		
Soldering	●							●
Solvent cleaning, welding/gluing	●					●		

*A combination of HEPA filter(s) and any other carbon filter type appropriate to the application may be used.

**The Paramount Ductless Enclosure is not designed to accommodate changing and disposing of biohazardous filters and materials and, therefore, should not be used as a biosafety enclosure.

Paramount Width	No. of Filters Required (not included)*	Total Organic Vapor Filter Weight
2'	2	15 lbs. (6.8 kg)
3'	4	30 lbs. (13.6 kg)
4'	6	45 lbs. (20.4 kg)
5'	6	45 lbs. (20.4 kg)
6'	8	60 lbs. (27.2 kg)

*Labconco strongly recommends ordering and keeping an extra set of filters to have readily available when filters become saturated and require replacement. Sign up for the **Filter Reminder Email Service** at www.labconco.com.

Paramount Filters

Contain porous, coconut shell carbon for maximum adsorption. Roughing prefilters are adhered to both sides of each filter to remove dust and other particles. All impregnated carbon filters contain 25% activated carbon by weight.

Catalog Filter Number	Description	Shipping Weight (lbs./kg)
6938100	HEPA, 99.99% efficient particulate	9.0/4.0
6938200	Activated Carbon, Organic Vapor, 7.5 lbs.	12.5/5.7
6938201	Impregnated Carbon, Acid-Sulfur, 10 lbs.	15.0/6.8
6938202	Impregnated Carbon, Ammonia-Amine, 11 lbs.	16.0/7.3
6938203	Impregnated Carbon, Formaldehyde, 10 lbs.	15.0/6.8
6938204	Mixed Bed Carbon, 10 lbs. Contains approximately 43% Activated Carbon (Organic Vapor), 19% Acid-Sulfur, 19% Ammonia-Amine and 19% Formaldehyde by weight	15.0/6.8
6938205	Impregnated Carbon, Radioisotope, 10 lbs.	15.0/6.8

Filter Accessories

Catalog Number	Shipping Description	Weight (lbs./kg)
6924900	Syringe Kit for carbon filter saturation detection	1.0/0.5
6925700	Ammonia Detector Tubes, package of 3	0.5/0.2
6925800	Acid Gas Detector Tubes, package of 3	0.5/0.2
6926000	Formaldehyde Detector Tubes, package of 3	0.5/0.2



Work Surfaces

Paramount® Ductless Enclosures

Black Solid Epoxy Work Surfaces

Chemical-resistant, black solid epoxy work surfaces, offered in 2', 3', 4', 5' and 6' widths, are dished to contain spills and contoured to fit the dimensions of Paramount Ductless Enclosures.



Catalog Number	Nominal Width	For use with:	Dimensions (width x depth x thickness)	Shipping Weight (lbs./kg)
3909900	2'	Paramount	24.0" x 29.0" x 1.0"	50/23
3909901	3'	Paramount	36.0" x 29.0" x 1.0"	75/34
3909902	4'	Paramount	48.0" x 29.0" x 1.0"	100/45
3909906	4'	Paramount, Deep	48.0" x 35.5" x 1.0"	125/56
3909907	5'	Paramount	60.0" x 29.0" x 1.0"	125/56
3909908	5'	Paramount, Deep	60.0" x 35.5" x 1.0"	155/70
3909910	6'	Paramount	72.0" x 29.0" x 1.0"	150/68
3909911	6'	Paramount, Deep	72.0" x 35.5" x 1.0"	186/84

Stainless Steel Work Surfaces

Type 304 stainless steel work surfaces, offered in 4', 5' and 6' widths, include a 0.8" deep front trough to contain spills.



Catalog Number	Nominal Width	For use with:	Dimensions (width x depth x thickness)	Shipping Weight (lbs./kg)
3975504	4'	Paramount, Deep	48.0" x 35.5" x 0.8"	145/65
3975502	5'	Paramount	60.0" x 29.0" x 0.8"	150/68
3975503	5'	Paramount, Deep	60.0" x 35.5" x 0.8"	180/82
3975602	6'	Paramount	72.0" x 29.0" x 0.8"	180/82
3975603	6'	Paramount, Deep	72.0" x 35.5" x 0.8"	220/100

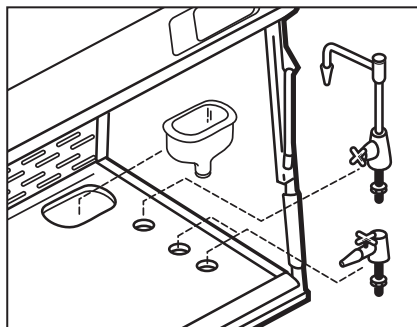

Work Surfaces with Deck-Mounted Service Fixtures

These chemical-resistant, black solid epoxy work surfaces, offered in 3', 4', 5' and 6' widths, are dished to contain spills and contoured to fit the dimensions of Paramount Ductless Enclosures. Pre-drilled holes allow installation of two deck-mounted service fixtures with hose barbs for plumbing to water, air and vacuum; a 3" x 6" cupsink; and a gooseneck faucet with vacuum breaker. Two standard chrome-plated service fixtures with turrets, hose barbs, brass valves and 3/8" NPS pipe connections; a 3" x 6" polypropylene oval cupsink; and a brass cold water faucet with swivel/ rigid gooseneck, brass valve and 1/4" NPS pipe connection are included.

Catalog Number	Nominal Width	For use with:	Dimensions (width x depth x thickness)	Shipping Weight (lbs./kg)
6963800	3'	Paramount	36.0" x 29.0" x 1.0"	85/38
6963801	4'	Paramount	48.0" x 29.0" x 1.0"	110/50
6963802	5'	Paramount	60.0" x 29.0" x 1.0"	135/61
6963803	6'	Paramount	72.0" x 29.0" x 1.0"	160/72



SoLo™ Hydraulic Lift Base Stands & Accessories

Paramount® Ductless Enclosures



Solo Hydraulic Lift Base Stand 3780311

SoLo™ Hydraulic Lift Base Stands

Allow Paramount transport through standard doorways. For example, Paramount 6963403 mounted atop Work Surface 3909906 may be lowered to 71.2". Epoxy-coated steel. Remote-control operated hydraulic lift provides infinitely adjustable work surface heights from 15.2" to 34.8" high. Depth is 34.3". Toe-locking casters, 5" diameter, with bearings. **Work surface is required.**

Catalog Number	Nominal Width	Actual Width	Electrical Requirements	Shipping Weight (lbs./kg)
3780310	3'	53.5"	115 volts, 60 Hz, 2 amps	395 lbs./179 kg
3780314*	3'	53.5"	230 volts, 50 Hz, 3 amps	395 lbs./179 kg
3780311	4'	65.5"	115 volts, 60 Hz, 2 amps	435 lbs./197 kg
3780315*	4'	65.5"	230 volts, 50 Hz, 3 amps	435 lbs./197 kg
3780312	5'	77.5"	115 volts, 60 Hz, 2 amps	460 lbs./209 kg
3780316*	5'	77.5"	230 volts, 50 Hz, 3 amps	460 lbs./209 kg
3780313	6'	89.5"	115 volts, 60 Hz, 2 amps	600 lbs./272 kg
3780317*	6'	89.5"	230 volts, 50 Hz, 3 amps	600 lbs./272 kg

♿ Comply with height and knee clearance guidelines outlined in Americans with Disabilities Act (ADA) Standards for Accessible Design. * International electrical configuration

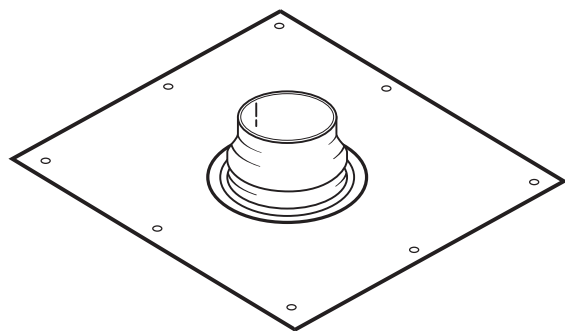

6963700 Canopy Exhaust Transition

Allows the Paramount Ductless Enclosure to be thimble-ducted to the outside for additional protection. The canopy's air gap provides a means of balancing air by allowing room air to enter the ductwork and mix with the filtered air being exhausted from the Paramount. **House exhaust or remote blower and ductwork are required (not included).** 6" (15 cm) diameter outlet. 6' Paramount Enclosures require two Exhaust Transitions. **Requires installation.** See back pocket for ordering information on remote blowers and ductwork. Shipping weight 18 lbs. (8 kg)



Sash Closures

Bi-fold doors allow the sash opening to be closed to prevent contaminants from entering the enclosure during periods of non-use. Include epoxy-coated steel doors and mounting hardware. **Require installation.**

Catalog Number	Sash Closure Dimensions	Shipping Weight (lbs./kg)
6963900	24.0" w x 9.4" h	10/5
6963901	36.0" w x 9.4" h	12/6
6963902	36.0" w x 12.0" h	15/7
6963903	48.0" w x 9.4" h	16/7
6963904	48.0" w x 12.0" h	20/9
6963905	60.0" w x 9.4" h	25/12
6963906	72.0" w x 12.0" h	30/14

See additional base stands and cabinets to support Paramount Ductless Enclosures on pages 105-116. See ordering information on Utility Shelves, Bottle Holder and Tissue Holder on page 121.



3' Protector XVS Ventilation Station 4863010 is shown with FilterMate Portable Exhauster 3970001, Solid Epoxy Dished Work Surface 3908401 and Telescoping Base Stand with Casters 3746711.

Inset: *3' Protector XVS Ventilation Station 4863030 is shown with Solid Epoxy Dished Work Surface 3908401 and Telescoping Base Stand 3746701.*



Requires Ductwork and Blower



Protector® XVS™ Ventilation Stations

Features & Benefits

Protector XVS Ventilation Stations provide an economical alternative to traditional fume hoods. With their low profile and clear sides, top and sash, Protector XVS Ventilation Stations are well suited for classroom and educational laboratory environments where supervision or demonstrations are required. They may also be used as weighing stations, light duty fume hoods, solvent cleaning work bays, and veterinary pathology and cytology enclosures. With smaller working heights and available in widths from 2', XVS Stations exhaust less tempered room air and con-

serve more energy than traditional hoods. They have no switches, wiring or service fixtures that add incremental costs.

Protector XVS Stations may be connected to a remote blower and exhausted to the outside. Alternatively, they may be connected to the FilterMate Portable Exhauster(s), which uses a carbon filter(s), a HEPA filter(s) or HEPA/carbon filter combination to remove fumes and vapors and/or hazardous particulates from the exhaust air without ducting.

Tempered safety glass front sash, sides and top offer excellent visibility, ambient light and protection. Glass provides better fire, scratch and chemical resistance than acrylic and dissipates static charge.

Sturdy glacier white and gray, dry powder epoxy-coated aluminum frame and steel rear plenum and baffle dissipate static charge and provide durability and better chemical resistance compared to acrylic models. No plastic-to-plastic bonding is used.

Upper dilution air supply introduces room air at the top of the sash to dilute contaminants in the upper chamber and bathes the back of the sash with clean air.

Patented* rear baffle with zones of perforations promotes horizontal laminar airflow to maximize containment. The baffle pivots down and is easily removable for cleaning.

Ergonomic angled sash allows a closer view, reduces glare and provides a more comfortable operating position than vertical sashes.

Patented* upper containment sash foil bleeds air into the enclosure to direct concentrations of contaminants away from the operator's breathing zone.

Deep interior easily accommodates a variety of apparatus including large balances. Models are available with a 23.4" interior depth. Some 5', 6' and 8' models have 30.0" interior depths.

8", 10" or 12" high sash opening limits exhaust demand, conserves costly tempered room air and requires a smaller remote blower than most fume hoods.

Side-entry air foils allow air to sweep across the interior glass surfaces to enhance containment.

Patented* Clean-Sweep™ air foil allows air to sweep the work surface for maximum containment. Airflow openings pull inflow air from under the air foil so that clean air continually flows through the air foil creating a constant barrier of protection from contaminants.

Two utility ports allow passage of tubing, electrical cords and interface cables from inside to back exterior for connection to services.

Modified ASHRAE 110-1995 conformity independently verified by ECT, Inc.

Particulate containment independently verified by SafeBridge Consultants, Inc.**

Flexible exhaust options. Rectangular exhaust openings on the top and bottom allow the Protector XVS Ventilation Station to be connected to ductwork for exhausting to the outside or to FilterMate™ Portable Exhauster(s) for filtered removal of fumes, particulates or powders. Using the bottom exhaust opening keeps ductwork hidden, maximizing room visibility.

Low profile design requires less space than most ventilated enclosures.



Left-side mounted waste chute, standard on some 5', 6' and 8' models, isolates contaminated waste in a sealable bag.

Exclusive Feature

* U.S. Patent No. 6,461,233

Other patent pending

**Contact Labconco for more information.



Protector® XVS™ Ventilation Stations



At far left: 6' Protector XVS Ventilation Station 4868060 is shown with Solid Epoxy Dished Work Surface 3908411 and Protector Standard Storage Cabinets 9904300 and 9904000. Blower, ductwork, work surface and supporting base must be ordered separately. At left: 2' Protector XVS Ventilation Station 4862030 is shown with Solid Epoxy Dished Work Surface 3908400 and Telescoping Base Stand 3747000. Blower, ductwork, work surface and supporting base must be ordered separately.



Requires
Ductwork and
Blower

All models feature:

- By-pass airflow design.
- Deep interior of 23.4" or 30.0" depending on the model.
- Clean-Sweep* air foil.
- Upper dilution air supply.
- Upper containment sash foil.
- Zone-perforated, pivoting rear baffle.*
 - Side-entry air foils.
 - Glacier white and gray, dry powder epoxy-coated aluminum frame and steel rear plenum and baffle. No plastic-to-plastic bonding is used.
- Clear 1/4" thick tempered safety glass front sash, sides and top.
- Ergonomic 20° angled and hinged, pivoting sash with wiping seal. Sashes on 5', 6' and 8' models incorporate an external gas-assist lift.
 - Models with 8.0" sash opening height have 16.5" locking height and 19.0" maximum loading height. Models with 10.0" or 12.0" sash opening height have 25.75" locking height and 28.25" maximum loading height.
 - Two utility ports with iris openings and plastic plugs.
 - 2" x 10" rectangular exhaust openings at the top and bottom. 5', 6' and 8' models include three openings on the top and bottom. Cover(s) provided for unused openings.
- Particulate containment independently verified by SafeBridge Consultants, Inc.††
- Modified ASHRAE 110-1995 conformity as low as 50 fpm independently verified by ECT, Inc.††

All models conform to the following regulations and standards:

- SEFA 1-2006
- Modified ASHRAE 110-1995
- ANSI Z9.5-2003

5', 6' and 8' models with 35.5" exterior depth include:

- Left-side mounted waste chute. Bags not included. Minimum bag size required: 10" x 16".

All models require:

- Remote blower or FilterMate Portable Exhauster(s) (each sold separately). See back pocket and pages 86-87 and 97.

- Work surface. See page 95.
- Supporting base. See pages 106-116.
- Ductwork. See pages 97-98 and back pocket.

Optional accessories:

- Guardian Airflow Monitors. See page 98.
- Fluorescent Task Lights. See page 96.
- Utility Shelves, Bottle Holder and Tissue Holder. See page 96.
- Exhaust Transition Adapters. See page 97.
- Waste Chute Stopper. See page 96.
- Waste Chute Bags. Contact your laboratory supply dealer.

Nominal Width	Height	Sash Opening Ht.	Total Exhaust CFM and Static Pressure (w.g.)					
			100 fpm	S.P.	80 fpm	S.P.	60 fpm	S.P.
2 Feet	Std.	8"	120	0.05"	95	0.03"	70	0.02"
2 Feet	Tall	10"	150	0.08"	120	0.05"	90	0.03"
3 Feet	Std.	8"	185	0.10"	145	0.06"	110	0.04"
3 Feet	Tall	10"	230	0.15"	185	0.10"	140	0.06"
4 Feet	Std.	8"	250	0.16"	200	0.10"	150	0.06"
4 Feet	Tall	10"	310	0.24"	250	0.16"	185	0.09"
5 Feet	Std.	8"	315	0.23"	250	0.15***	190	0.08"
5 Feet	Tall	12"	480	0.54"	385	0.35***	290	0.20"
6 Feet	Std.	8"	380	0.32"	305	0.21***	230	0.12"
6 Feet	Tall	12"	580	0.75"	465	0.48***	350	0.27"
8 Feet	Std.	8"	510	0.18"	410	0.12*†	310	0.07"
8 Feet	Tall	12"	775	0.42"	620	0.27*†	465	0.15"

** Static pressure when one center exhaust opening is used.

† Static pressure when two outer exhaust openings are used. Requires "T" Connector 3981600, not included. Contact Labconco.

†† Contact Labconco for more information.



Exclusive feature

*U.S. Patent No. 6,461,233



Ordering Information & Dimensional Data

Protector® XVS® Ventilation Stations

Protector® XVS Ventilation Stations

Nominal Width	Catalog Number	Overall Height (E) in./cm	Overall Depth (H) in./cm	(A) in./cm	(B) in./cm	(C) in./cm	(D) in./cm	(F) in./cm	(G) in./cm	(I) in./cm	(J) in./cm	(K) in./cm	Ship. Wt. lbs./kg
2 Feet	4862010	22.8/57.9	29.0/73.7	24.0/61.0	12.0/30.5	21.6/54.9	28.6/72.6	22.3/56.6	19.0/48.3	23.4/59.4	8.0/20.3	—	105/48
2 Feet	4862030	32.0/81.3	29.0/73.7	24.0/61.0	12.0/30.5	21.6/54.9	37.8/96.0	31.5/80.0	27.7/70.4	23.4/59.4	10.0/25.4	—	135/61
3 Feet	4863010	22.8/57.9	29.0/73.7	36.0/91.4	18.0/45.7	33.6/85.3	28.6/72.6	22.3/56.6	19.0/48.3	23.4/59.4	8.0/20.3	—	135/61
3 Feet	4863030	32.0/81.3	29.0/73.7	36.0/91.4	18.0/45.7	33.6/85.3	37.8/96.0	31.5/80.0	27.7/70.4	23.4/59.4	10.0/25.4	—	160/73
4 Feet	4864010	22.8/57.9	29.0/73.7	48.0/121.9	24.0/61.0	45.6/115.8	28.6/72.6	22.3/56.6	19.0/48.3	23.4/59.4	8.0/20.3	—	160/73
4 Feet	4864030	32.0/81.3	29.0/73.7	48.0/121.9	24.0/61.0	45.6/115.8	37.8/96.0	31.5/80.0	27.7/70.4	23.4/59.4	10.0/25.4	—	185/84
5 Feet	4865010	22.8/57.9	29.0/73.7	60.0/152.4	30.0/76.2	57.6/146.3	28.6/72.6	22.3/56.6	19.0/48.3	23.4/59.4	8.0/20.3	10.0/25.4	290/132
5 Feet	4865030	32.0/81.3	29.0/73.7	60.0/152.4	30.0/76.2	57.6/146.3	37.8/96.0	31.5/80.0	27.7/70.4	23.4/59.4	12.0/30.5	10.0/25.4	340/154
5 Feet*	4865060	32.0/81.3	35.5/90.2	60.0/152.4	30.0/76.2	57.6/146.3	37.8/96.0	31.5/80.0	27.7/70.4	30.0/76.2	12.0/30.5	10.0/25.4	380/172
6 Feet	4866010	22.8/57.9	29.0/73.7	72.0/182.9	36.0/91.4	69.6/176.8	28.6/72.6	22.3/56.6	19.0/48.3	23.4/59.4	8.0/20.3	10.0/25.4	340/154
6 Feet	4866030	32.0/81.3	29.0/73.7	72.0/182.9	36.0/91.4	69.6/176.8	37.8/96.0	31.5/80.0	27.7/70.4	23.4/59.4	12.0/30.5	10.0/25.4	395/179
6 Feet*	4866060	32.0/81.3	35.5/90.2	72.0/182.9	36.0/91.4	69.6/176.8	37.8/96.0	31.5/80.0	27.7/70.4	30.0/76.2	12.0/30.5	10.0/25.4	440/220
8 Feet	4868010	22.8/57.9	29.0/73.7	96.0/243.8	48.0/121.9	93.6/237.7	28.6/72.6	22.3/56.6	19.0/48.3	23.4/59.4	8.0/20.3	24.0/61.0	455/206
8 Feet	4868030	32.0/81.3	29.0/73.7	96.0/243.8	48.0/121.9	93.6/237.7	37.8/96.0	31.5/80.0	27.7/70.4	23.4/59.4	12.0/30.5	24.0/61.0	520/236
8 Feet*	4868060	32.0/81.3	35.5/90.2	96.0/243.8	48.0/121.9	93.6/237.7	37.8/96.0	31.5/80.0	27.7/70.4	30.0/76.2	12.0/30.5	24.0/61.0	580/263

*Includes waste chute

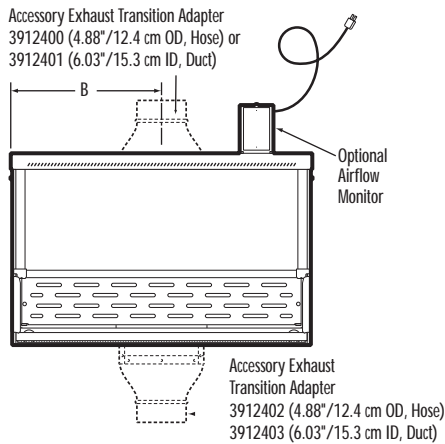

FRONT
(2', 3', 4' MODELS)

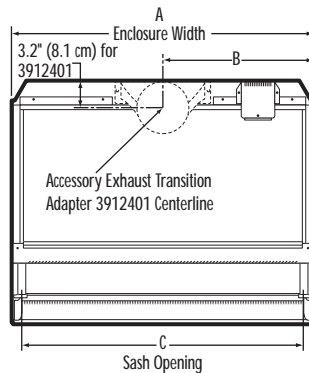

TOP
(2', 3', 4' MODELS)

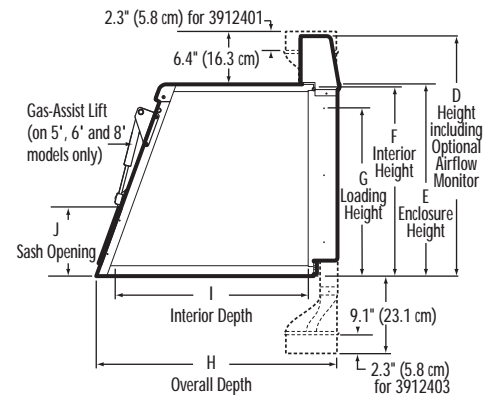

SIDE (ALL MODELS)

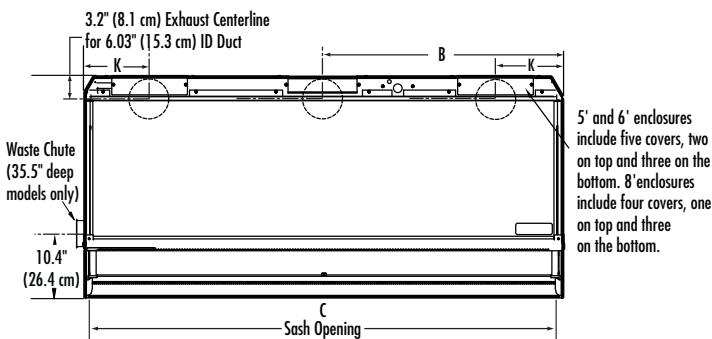

TOP
(5', 6', 8' MODELS)

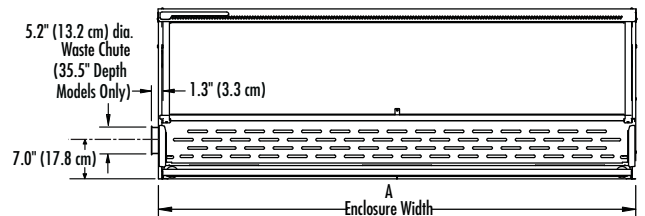

FRONT
(5', 6', 8' MODELS)

Contact Labconco at 800-821-5525 or 816-333-8811 or visit www.labconco.com for detailed AutoCAD drawings.



FilterMate™ Portable Exhausters



FilterMate Portable Exhauster 3970000.
Includes HEPA filter.



FilterMate Portable Exhauster 3970001.
Requires carbon filter (not included).



FilterMate Portable Exhauster 3970002.
Includes HEPA filter and thimble connection.
Requires ducting to outside.



FilterMate Portable Exhauster 3970003. Includes HEPA filter.
Requires carbon filter (not included).

An accessory for the Protector XVS Ventilation Station, Protector Demonstration Hood, Protector Work Station and XPert® Balance Enclosure, the FilterMate uses a HEPA filter, carbon filter or a combination of both filters to remove hazardous powders, particulates or vapors from the exhaust air stream and return filtered air to the environment.

All models feature:

- Compact, corrosion-resistant housing of glacier white and light gray, dry powder, epoxy-coated steel with rubber feet.
- Variable-speed, non-sparking motorized impeller.
- Quiet operation. Oversized HEPA filter, efficient impeller and perforated exhaust cover work together to provide lower system exhaust velocity and noise pressure levels.

Exhaust CFM	Noise Pressure dB(A)
100	45-47
150	51-54
200	56-61
250	63-65

- Inherently safe design. A negative pressure plenum surrounds the positive pressure impeller so that if a leak occurs, the unfiltered air is captured and refiltered.
- Sized for Protector Demonstration Hoods, Protector XVS Ventilation Stations, Protector Work Stations and XPert Balance Enclosures. Capable of efficiently filtering up to 250 CFM for HEPA or carbon filtration; up to 200 CFM for combination HEPA/carbon filtration (60-100 fpm depending on enclosure model).
- Front-mounted rocker switch to control power to the blower.
- Rear-mounted, auxiliary electrical outlet that may be connected to an airflow monitor or other user-supplied accessories.
- Only one FilterMate is required for all 2', 3' and 4' wide enclosures. Multiple FilterMates may be used for 5', 6' and 8' wide enclosures.

Exclusive Feature



- Included: 8 feet of 5" ID flexible gray polypropylene hose, two clamps and a 4.88" OD Upper Transition Adapter for connection to the top of the Protector XVS Ventilation Station, Protector Work Station or Protector Demonstration Hood. Models 3970004 and 3970024 include a 4.88" OD Lower Transition Adapter instead of the Upper Transition Adapter.
- 6.5' IEC three-wire electrical cord with plug (115 volt models).
- 9' IEC three-wire electrical cord. **An electrical plug is required (230 volt models).**

All models conform to the following regulations and standards:

- UL 3101-1/61010-1
- CAN/CSA C22.2 No. 1010.1
- CE Conformity Marking (230 volt models)

Models 3970000, 3970020, 3970002, 3970022, 3970003 and 3970023 feature:

- HEPA filter, 99.99% efficient on particulates 0.3 micron in size.
- True bag-in/bag-out filter disposal system for safely removing and replacing the filter without detaching the hose. The HEPA filter may be easily accessed by removing the exhaust cover for field leak testing by a certified technician.

Models 3970002 and 3970022 feature:

- 6.06" ID thimble connection from the FilterMate to an existing house exhaust system for added safety.

Models 3970001, 3970021, 3970003 and 3970023 require one each and Models 3970004 and 3970024 require two each (not included):

- Carbon Filter. Organic Vapor, Formaldehyde or Ammonia Filters are offered. See page 94.

Optional Accessories

- Replacement HEPA Filter. See page 94.
- Replacement Bag-In/Bag-Out Bag. See page 94.
- Flexible Hose. See page 96.
- Thimble Connection. See page 96.



Ordering Information & Dimensional Data

FilterMate™ Portable Exhausters

FilterMate™ Portable Exhausters

Catalog Number	Filter Usage	Overall Dimensions	Electrical Requirements	Airflow Potential	Exhaust Connection	Shipping Weight lbs./kg
3970000	HEPA included	14.0" w x 23.0" d x 22.7" h	115 volts, 60 Hz	250 CFM (60-100 fpm)	None. Room exhaust.	50/23
3970020*	HEPA included	14.0" w x 23.0" d x 22.7" h	230 volts, 50 Hz	250 CFM (60-100 fpm)	None. Room exhaust.	50/23
3970001	Carbon required†	14.0" w x 23.0" d x 22.7" h	115 volts, 60 Hz	250 CFM (60-100 fpm)	None. Room exhaust.	48/22
3970021*	Carbon required†	14.0" w x 23.0" d x 22.7" h	230 volts, 50 Hz	250 CFM (60-100 fpm)	None. Room exhaust.	48/22
3970002	HEPA included	18.6" w x 23.0" d x 24.7" h	115 volts, 60 Hz	250 CFM (60-100 fpm)	6.06" ID Thimble to outside	54/25
3970022*	HEPA included	18.6" w x 23.0" d x 24.7" h	230 volts, 50 Hz	250 CFM (60-100 fpm)	6.06" ID Thimble to outside	54/25
3970003	HEPA included†† Carbon required†	14.9" w x 23.0" d x 22.7" h	115 volts, 60 Hz	200 CFM (60-100 fpm)**	None. Room Exhaust.	52/24
3970023*	HEPA included†† Carbon required†	14.9" w x 23.0" d x 22.7" h	230 volts, 50 Hz	200 CFM (60-100 fpm)**	None. Room Exhaust.	52/24
3970004	Two Carbon required†	14.9" w x 23.0" d x 22.7" h	115 volts, 60 Hz	200 CFM (60-100 fpm)**	None. Room Exhaust.	52/24
3970024	Two Carbon required†	14.9" w x 23.0" d x 22.7" h	230 volts, 50 Hz	200 CFM (60-100 fpm)**	None. Room Exhaust.	52/24

* International electrical configuration † Carbon Filter is not included. †† HEPA filter may be removed and substituted with a second carbon filter. ** 60-80 fpm on 4' enclosure.

Models 3970000, 3970001, 3970020 & 3970021

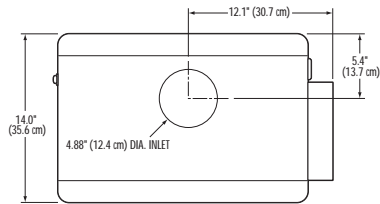

TOP

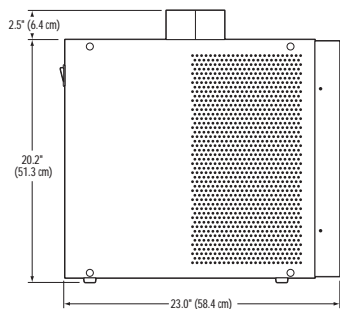

SIDE

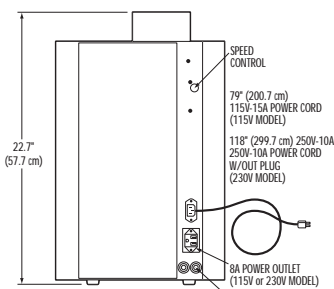

REAR

Models 3970002 & 3970021

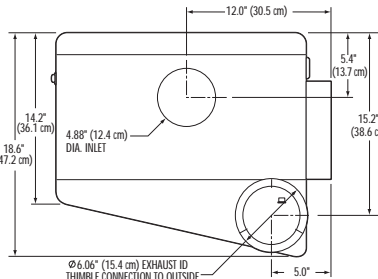

TOP

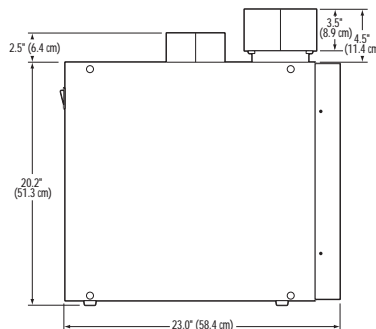

SIDE

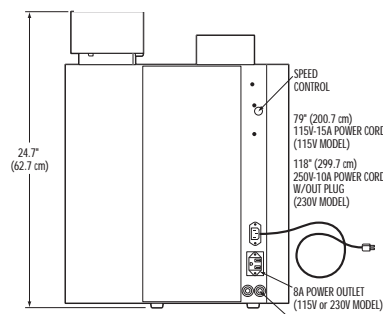

REAR

Models 3970003 & 3970023

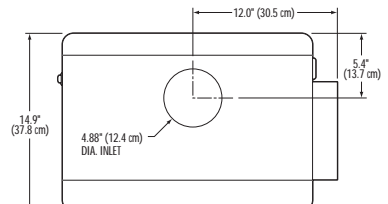

TOP

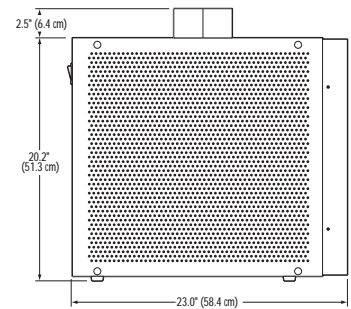

SIDE

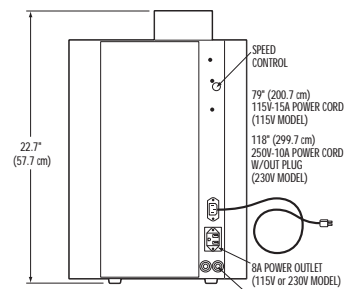

REAR



Protector® Demonstration Hoods



Protector Demonstration Hood System 3945001.

Protector Demonstration Hoods are low profile, light-duty fume hoods designed to provide 360° of close observation of procedures during educational demonstrations.

All models feature:

- Deep 23" interior that easily accommodates a variety of apparatus.
- Patented* Clean-Sweep™ air foil that allows air to sweep the work surface for maximum containment. Airflow openings pull inflow air from under the air foil so that clean air continually flows through the air foil creating a constant barrier of protection from contaminants.
- Upper containment sash foil that bleeds air into the enclosure to direct concentrations of contaminants away from the operator's breathing zone.
- Upper dilution air supply that introduces room air at the top of the sash to dilute concentrations in the upper chamber and bathes the back of the sash with clean air.
- Clear rear baffle that directs air streams to the back of the interior for removal through the exhaust connection. The baffle may be pivoted downward for cleaning.
- Side-entry air foils that allow air to sweep across the interior glass surfaces to enhance containment.
- Sturdy glacier white and gray, dry powder epoxy-coated aluminum frame.

- Tempered safety glass front sash, sides, rear baffle and top that offer excellent 360° visibility, ambient light and protection. Glass provides better fire, scratch and corrosion resistance than acrylic.
- 8" high sash opening that limits exhaust demand, conserves costly tempered room air and requires a smaller remote blower than most fume hoods. Tall models, 32.0" high, have a 10" high sash opening.
- Ergonomic angled sash allows a closer view, reduces glare and provides a more comfortable operating position than vertical sashes. Models, 22.8" high, have a 20° angle; models, 32.0" high, have a 14° angle. The hinged sash pivots upward and locks to a loading height of 19.0" or 27.7" depending on the model.
- Lower exhaust tissue screen.
- Two utility ports with iris openings that allow passage of tubing, electrical cords and interface cables from inside to back exterior for connection to services.
- Flexible exhaust options. 2" x 10" rectangular exhaust collars on the top and bottom allow the Protector Demonstration Hood to be connected to ductwork for exhausting to the outside or to a FilterMate Portable Exhauster for filtered removal of fumes and/or particulates. Using the bottom exhaust collar keeps ductwork hidden, maximizing room visibility.

All models conform to the following regulations and standards:

- SEFA 1-2006
- Modified ASHRAE 110-1995
- ANSI Z9.5-2003
- UL 3101-1/61010-1 (115 volt models)
- CAN/CSA C22.2 No. 1010.1 (115 volt models)
- CE Conformity Marking (230 volt models)

Nominal Width	Overall Height	Sash Opening Height	Total Exhaust CFM and Static Pressure					
			100 fpm	S.P.	80 fpm	S.P.	60 fpm	S.P.
3 Feet	22.8"	8"	185	0.10"	145	0.06"	110	0.04"
3 Feet	32.0"	10"	230**	0.15"	185	0.10"	140	0.06"

■ Exclusive Feature

* U.S. Patent No. 6,461,233

** FilterMate Portable Exhauster with two filters provides up to 220 CFM and with single filter provides up to 270 CFM.

System Models 3945000, 3945001, 3945020 & 3545021 also include:

- Cart of glacier white epoxy-coated tubular steel with black 1" thick solid epoxy dished work surface, handle bar, bottom shelf and 4" diameter toe-locking casters.
- FilterMate Portable Exhauster designed for use with two Carbon Filters or one Carbon Filter and one HEPA Filter (Filters are not included. See pages 94-95 for ordering information.) Includes 8 feet of 5" ID flexible gray polypropylene hose, two clamps, a 4.88" OD Lower Transition Adapter for connection to the bottom of the Protector Demonstration Hood, and an IEC 3-wire electrical cord with plug.

Models 3944300 & 3944301 require:

- **Connection to a remote blower, house exhaust or FilterMate Portable Exhauster.** See pages 86-87 for FilterMate. See pages 97-98 for Remote Blowers and ductwork.
- **Work surface and supporting base.** See page 98 for Cart. See page 95 for work surface and pages 106-116 for Base Cabinets and Stands.

Accessories include:

- Fluorescent Task Lights. See page 96.
- Exhaust Transition Adapters. See page 97.
- Exhaust Dampers. See page 97.
- Guardian Airflow Monitors. See page 98.
- Cart. See page 98.
- Remote Blowers. See back pocket and pages 86-87 and 97.



Ordering Information & Dimensional Data

Protector® Demonstration Hoods

Nominal Catalog Width	Number	Electrical Requirements	Enclosure Height	Shipping Weight lbs./kg
Protector Demonstration Hoods				
3 Feet	3944300	not applicable	22.8"	75/34
3 Feet	3944301	not applicable	32.0"	85/39
Protector Demonstration Hood Systems - include Cart with Work Surface, Lower Transition Adapter and FilterMate Portable Exhauster for use with two Carbon Filters or one Carbon Filter and one HEP A Filter in any combination. *				
3 Feet	3945000	115 volts, 60 Hz, 10 amps	22.8"	125/57
3 Feet	3945001	115 volts, 60 Hz, 10 amps	32.0"	135/61
3 Feet	3945020**	230 volts, 50/60 Hz, 5 amps	22.8"	125/57
3 Feet	3945021**	230 volts, 50/60 Hz, 5 amps	32.0"	135/61

* Filters are required but not included. See pages 94-95 for ordering information.

** International electrical configuration

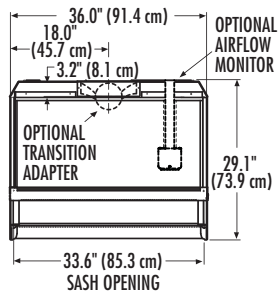

TOP
(3944300 & 3944301)

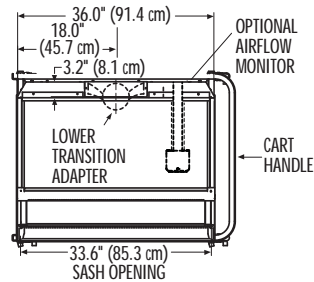

TOP
**(3945000, 3945001,
3945020 & 3945021)**

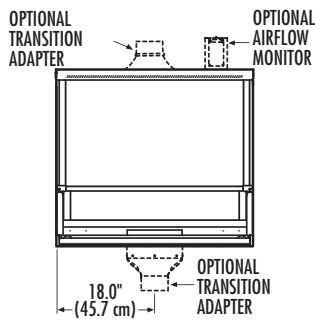

FRONT
(3944300 & 3944301)

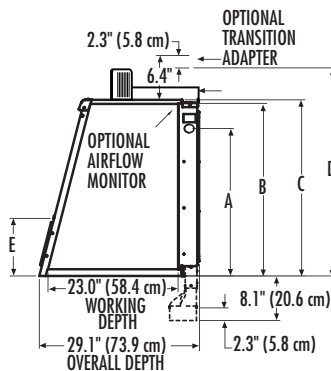

SIDE
(3944300 & 3944301)

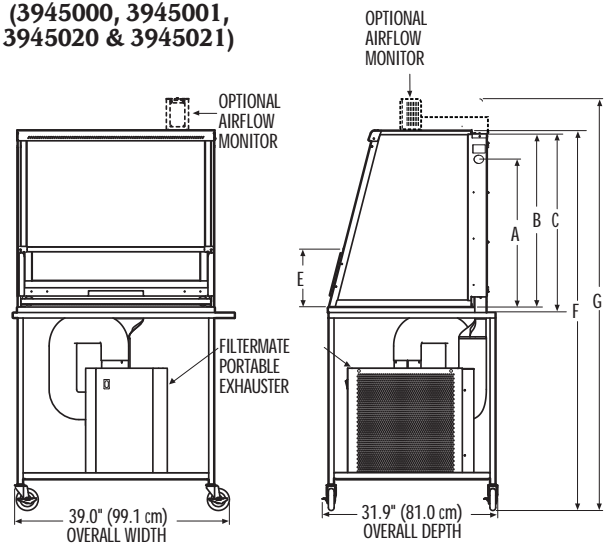

FRONT
**(3945000, 3945001,
3945020 & 3945021)**

SIDE
**(3945000, 3945001,
3945020 & 3945021)**

	A	B	C	D	E	F	G
3944300, 3945000 & 3945020	19.0" (48.3 cm) loading height	22.3" (56.4 cm) interior height	22.8" (57.9 cm) enclosure height	28.6" (72.6 cm) height w/ monitor	8.0" (20.3 cm) sash opening	58.8" (149.4 cm) height w/cart	64.6" (164.1 cm) height w/cart & monitor
3944301, 3945001 & 3945021	27.7" (70.4 cm) loading height	31.5" (80.0 cm) interior height	32.0" (81.3 cm) enclosure height	37.9" (96.3 cm) height w/ monitor	10.0" (25.4 cm) sash opening	68.0" (172.7 cm) height w/cart	73.9" (187.7 cm) height w/cart & monitor



Protector Work Station 3930001 is shown on Work Surface with Sink 6942003 and Telescoping Base Stand 3746702.

***Inset:** Protector Work Station 3930000 is shown on Solid Epoxy Work Surface 3908402 and Telescoping Base Stand 3746702.*



Requires
Ductwork and
Blower



Protector® Work Stations

Features & Benefits

Protector Work Stations are specifically designed for the needs of pathologists and histotechnologists. These enclosures rely on patented* containment-enhancing features and face velocities from 60 to 100 fpm to rid the laboratory of solvent vapors associated with gross sectioning, trimming, coverslipping and staining.

Protector Work Stations are available in two configurations. Models designed for connection to a remote blower or house exhaust system offer protection from a broad range of chemicals and are recommended when chemical concentrations are high, unknown or unpredictable. In lieu of outside ducting, these

models may also be connected to the FilterMate Portable Exhauster, which returns filtered air to the laboratory. The FilterMate Portable Exhauster and Filters are sold separately.**

Alternatively, if ducting to the outside is not feasible, Protector Work Stations with built-in blower are available. These enclosures accommodate two large carbon filters — Organic, Formaldehyde and Ammonia — used in any combination. The filters keep low concentrations of these chemicals below OSHA-recommended time-weighted average (TWA) levels, restoring clean air to the laboratory. Carbon Filters are sold separately.

Patented* Type 304 stainless steel rear baffle with zones of perforations promotes horizontal laminar airflow to maximize containment. The baffle pivots down and is easily removable for cleaning. On Models 3930000 and 3930020, the area behind the baffle accommodates two Carbon Filters (sold separately).

Glare-free fluorescent lighting.

Two convenient utility ports with iris openings (Models 3930001 and 3930021 only) allow passage of tubing and electrical cords from equipment inside the enclosure through the back for connection to services. Plugs are provided to seal the ports when not in use.

Side-entry air foils allow air to sweep across the interior side glass surfaces to enhance containment.

Patented* Clean-Sweep™ air foil allows air to sweep the work surface for maximum containment. Airflow openings pull inflow air from under the air foil so that clean air continually flows through the air foil creating a constant barrier of protection from contaminants. The air foil's ergonomic design provides a comfortable position for the operator's forearms.

Flexible exhaust options (Models 3930001 and 3930021 only). 2" x 10" rectangular exhaust openings on the top and bottom allow the Protector Work Station to be connected to ductwork for exhausting to the outside or to a FilterMate Portable Exhauster** for filtered removal of vapors, particles or a combination of both. Using the bottom exhaust opening keeps ductwork hidden, maximizing room visibility.

Rear-mounted electrical receptacle, activated by the blower switch, may be used to provide power to the optional Guardian Airflow Monitor.

ETL-listed. All 115 volt models carry the ETL mark signifying that they are certified to UL 3101-1/61010-1 and CAN/CSA C22.2 No. 1010.1.

Ergonomic 20° angled sash allows a closer view, reduces glare and provides a more comfortable operating position than vertical sashes. The hinged sash with spring-loaded latch pivots upward and locks to a height of 19.0" for loading and cleaning. The sash's wiping seals help keep contaminants contained.

Performance tested to modified ASHRAE 110-1995.

Upper dilution air supply introduces room air at the top of the sash to dilute contaminants in the upper chamber and bathes the back of the sash with clean air.

Optional Guardian 1000 Digital or Guardian 500 Airflow Monitor alerts the user to face velocities outside of preset range. The Guardian 1000 Digital Monitor also has a RS232 port for connection to a user-supplied computer.

Front-mounted light and blower switches.



Sturdy and chemical-resistant construction. The frame and rear plenum are glacier white and gray, dry powder epoxy-coated aluminum and steel. The sides and front sash are fire-, scratch- and chemical-resistant 1/4" thick tempered safety glass.

Built-in motorized impeller (Models 3930000 and 3930020 only) is dynamically-balanced for quiet operation.

Speed control (Models 3930000 and 3930020 only) allows a certified technician to validate and adjust the speed of the motorized impeller to achieve the desired inflow velocity.

CE mark. All 230 volt, 50 Hz models conform to the CE (European Community) requirements for electrical safety and electromagnetic compatibility.

8" high sash opening limits exhaust demand, conserves costly tempered room air and requires a smaller remote blower than most fume hoods.

Patented* upper containment sash foil bleeds air into the enclosure to direct concentrations of contaminants away from the operator's breathing zone.



Optional Work Surface 6942003 of solid black epoxy is corrosion and stain resistant and dished to contain spills. Includes a 10" x 14" x 6" deep molded epoxy sink; corrosion-resistant, chrome-plated gooseneck fixture with vacuum breaker and two faucet controls. A retractable hose with spray nozzle speeds clean up. A Solid Epoxy Work Surface without sink is also available.

Exclusive Feature

* U.S. Patent No. 6,461,233

** See pages 86-87 for or dering information on FilterMate Portable Exhausters.



Protector® Work Stations



Protector Work Station 3930001 is shown on Work Surface with Sink 6942003 and Telescoping Base Stand 3746702. Blower, ductwork, work surface and supporting base must be ordered separately.

Models 3930000 and 3930020 are designed for use with two carbon filters (not included) and feature:

- Built-in dynamically-balanced motorized impeller.
- Speed control.
- Baffle with two release knobs that pivots down for filter access.
- Quiet operation. See chart below.

Models 3930000 and 3930020 require (not included):

- Two Carbon Filters. See pages 94-95.

Models 3930001 and 3930021 are designed for use with remote blower or FilterMate Portable Exhauster and feature:

- 2" x 10" rectangular exhaust openings on the top and bottom.
- Two utility ports with iris openings and plugs.
- Static pressure loss from 0.06" to 0.16". See chart below.

Models 3930001 and 3930021 require (not included):

- Remote blower, house exhaust or FilterMate Portable Exhauster. See page 97 for Remote Blower. See pages 86-87 for FilterMate.
- Ductwork. See pages 97-98.

All models require (not included):

- Supporting work surface. See page 95.
- Supporting base. See pages 106-116.

Optional accessories include:

- Guardian Airflow Monitors. See page 98.
- Exhaust Transition Adapters. See page 97.
- Utility Shelves, Bottle Holder and Tissue Holder. See page 96.
- Remote Blowers. See back pocket and pages 86-87 and 97.

All models feature:

- Clean-Sweep* air foil.
- Upper dilution air supply.
- Upper containment sash foil.*
- Zone-perforated Type 304 stainless steel rear baffle that pivots down and is removable for cleaning.*
- Side-entry air foils.
- Glacier white and gray, dry powder epoxy-coated aluminum frame and steel rear plenum.
- 1/4" thick tempered safety glass front sash and sides.
- 8" high sash opening.
- Ergonomic 20° angled and hinged sash with wiping seals and spring-loaded latch that pivots upward and locks to a 19.0" height.
- Fluorescent lighting.
- Light and blower switches.
- Exterior rear-mounted electrical receptacle.

All models conform to the following regulations and standards:

- SEFA 1-2006
- Modified ASHRAE 110-1995
- ANSI Z9.5-2003
- UL 3101-1/61010-1 (115 volt models)
- CAN/CSA C22.2 No. 1010.1 (115 volt models)
- CE Conformity marking (230 volts models)

Face Velocity (fpm)	Exhaust Volume (CFM)	Noise Pressure db(A) (Models 3930000 & 3930020)	Static Pressure Loss (Inches of H ₂ O) (Models 3930001 & 3930021)
60	150	57-59	0.06"
80	200	62-64	0.10"
100	250	69-71	0.16"

* U.S. Patent No. 6,461,233





Ordering Information & Dimensional Data

Protector® Work Stations

Catalog Number	Electrical Requirements	Power Cord & Plug	Blower	Carbon Filters*	Shipping Weight lbs./kg
3930000	115 volts, 60 Hz, 10 amps	6.5'	Built-in	Requires two	120/54
3930001	115 volts, 60 Hz, 10 amps	6.5'	Requires remote blower, house exhaust or FilterMate Portable Exhauster**		100/45
3930020	230 volts, 50 Hz, 5 amps	9'. No Plug.	Built-in	Requires two	120/54
3930021	230 volts, 50 Hz, 5 amps	9'. No Plug.	Requires remote blower, house exhaust or FilterMate Portable Exhauster**		100/45

* See pages 94-95 for ordering information. ** See page 97 for ordering information on Remote Blowers and pages 86-87 for ordering information on FilterMate Portable Exhausters.

3.2" (8.1 cm) CENTERLINE OF OPTIONAL TRANSITION ADAPTER 3912401

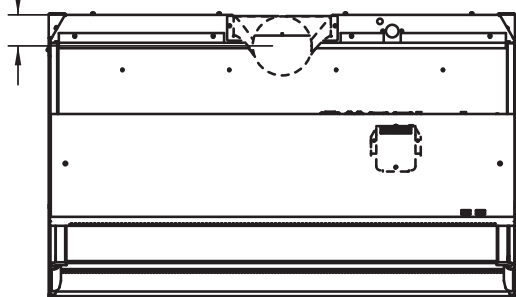

TOP VIEW
(Models 3930001 & 3930021)

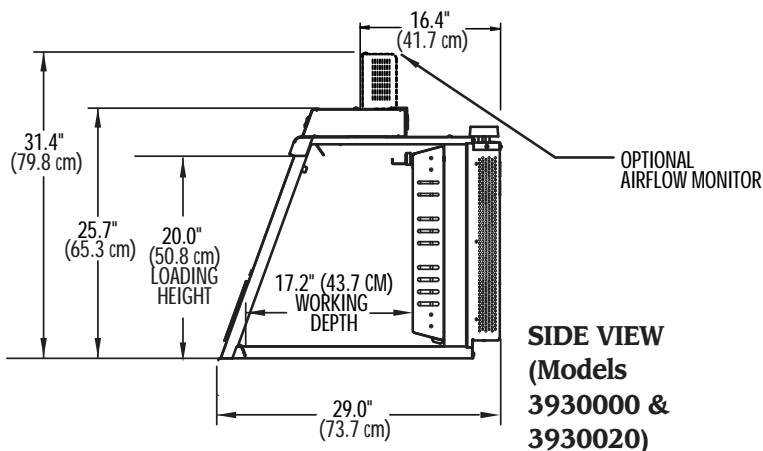

SIDE VIEW
(Models 3930000 & 3930020)

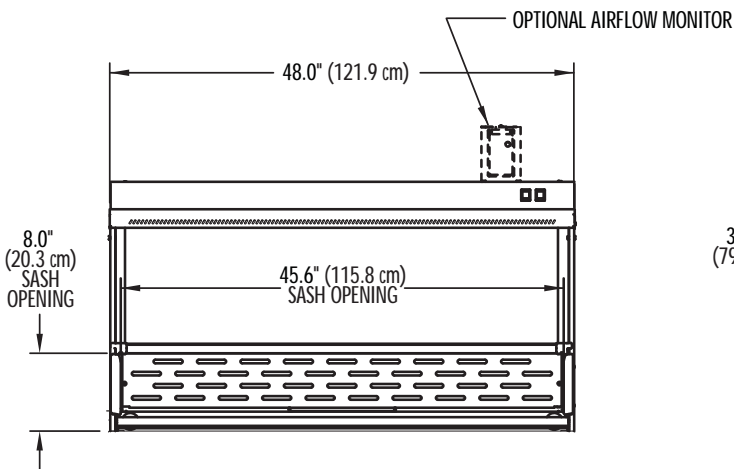

FRONT VIEW
(All Models)

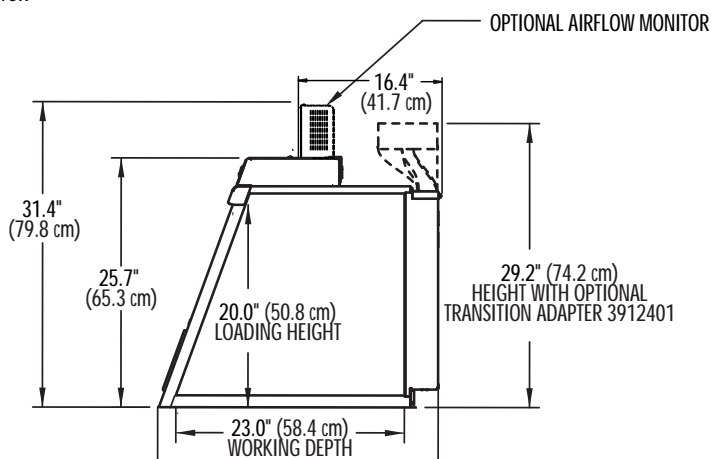

SIDE VIEW
(Models 3930001 & 3930021)



Carbon and HEPA Filters

FilterMate™ Portable Exhausters & Protector® Work Stations

Below is an Application Matrix that provides examples of appropriate uses for carbon and/or HEPA filters expended in the FilterMate Portable Exhauster or Protector Work Station. Whether or not any ductless enclosure is appropriate for your application requires consideration of factors such as the time-weighted exposure limits of your materials. Using Labconco's exclusive chemical assessment program, our technical specialists can help you determine if a Labconco ductless enclosure is the right ventilation product for your application and, if so,

estimate filter life. To begin the process, please complete the **Chemical Usage Assessment Form** available on our website at www.labconco.com or call us at **800-821-5525** or **816-333-8811**.

Carbon and HEPA Filters are available in a variety of types and, in some cases, may be used in carbon/HEPA filter combination. An online **Chemical Guide**, available at www.labconco.com, allows you to search individual chemicals to determine their suitability for use with a carbon-filtered enclosure.

- **Organic Filters** are suitable for vapors from solvents including acetone, ethyl acetate, toluene and xylene.
- **Formaldehyde Filters** are suitable for vapors from formaldehyde, formalin and gluteraldehyde.
- **Ammonia Filters** are suitable for ammonia and low molecular weight amines.
- **HEPA Filters**, 99.99% efficient, are suitable for removing particulates such as powders and pollen. **They should not be used to capture biohazardous materials or volatile organic material.**

Application Matrix

Filter Type Configuration	FilterMate & Protector Work Station			FilterMate	
	Organic	Ammonia	Formaldehyde	Carbon	& HEPA* HEPA
Asbestos handling					•
Clean room/critical environment				•	
Combination dry and liquid chemicals				•	
Drug compounding/research				•	•
Endoscopy instrument cleaning			•		
Histology/cytology tissue staining, coverslipping	•				
Histology/pathology	•			•	
Hormone research				•	•
Non-biohazardous microbiological samples with trace chemicals**				•	
Particulates in conjunction with chemical agents				•	
Pathology/tissue grossing			•	•	
Photo-engraving		•			
Plastics production		•			
Pollen handling				•	•
Soldering				•	•
Solvent cleaning	•				
Solvent welding/gluing	•				
Weighing chemical powders				•	•

*Carbon filter type varies based on application

**The FilterMate Portable Exhauster is not designed to accommodate changing and disposing of biohazardous filters and materials and, therefore, should not be used as part of a biosafety enclosure.



Carbon and HEPA Filters and Accessories for use with FilterMate Portable Exhausters

A HEPA Filter and Bag-In/Bag-Out Bag are included with FilterMate Portable Exhausters designed for use with HEPA filters. One or two Carbon Filters are required for operation with FilterMate Portable Exhausters designed for use with carbon filters.

Catalog #	Description	Shipping Wt. lbs./kg
3923400	Organic Carbon Filter, Type AC. Contains 12 pounds of granular activated carbon media.	14/6.3
3923401	Formaldehyde Carbon Filter, Type ST-1. Contains a minimum of 14 pounds of impregnated carbon media.	17/7.7
3923402	Ammonia Carbon Filter, Type AC. Contains a minimum of 16 pounds of impregnated carbon media.	21/9.5
3707900	Replacement HEPA Filter, 99.99% efficient on particles 0.3 micron in size.	10/4.5
3776002	Replacement Bag-In/Bag-Out Bag to ensure containment of particulate matter during HEPA filter changing.	1/0.5
1968800	Orange Cinching Strap for Bag-In/Bag-out Bag.	1/0.5

*Labconco strongly recommends ordering and keeping an extra set of filters to have readily available when filters become saturated and require replacement. Sign up for the **Filter Reminder Email Service** at www.labconco.com.



Carbon and HEPA Filters

FilterMate Portable Exhausters & Protector® Work Stations



Carbon Filters for use with Protector Work Stations and Accessories for use with Protector Work Stations and FilterMate Portable Exhausters

Protector Work Stations 3930000 or 3930020 require two each Carbon Filters, either two of the same filter or a combination of two filters.

Catalog #	Description	Shipping Wt. lbs./kg
3924200	Organic Carbon Filter, Type RL10. Contains 11 pounds of granular activated carbon media.	12/5.4
3924201	Formaldehyde Carbon Filter. Contains a minimum of 13 pounds of impregnated carbon media.	14/6.4
3924202	Ammonia Carbon Filter. Contains a minimum of 15 pounds of impregnated carbon media.	16/7.3
6925700	Ammonia Detector Tubes, package of 3.	0.5/0.2
6926000	Formaldehyde Detector Tubes, package of 3.	0.5/0.2
6924900	Syringe Kit for carbon filter saturation detection.	1/0.5

*Labconco strongly recommends ordering and keeping an extra set of filters to have readily available when filters become saturated and require replacement. Sign up for the **Filter Reminder Email Service** at www.labconco.com.

Work Surfaces

Protector® XVS Ventilation Stations, Protector® Demonstration Hoods & Protector® Work Stations



Solid Epoxy Work Surfaces

Black work surfaces are contoured to fit the dimensions of Protector XVS Ventilation Stations, Protector Demonstration Hoods and Protector Work Stations and dished to contain spills. One inch thick molded solid epoxy is chemical resistant and fire proof.

Catalog #	Dimensions	For use with:	Shipping Wt. lbs./kg
3908400	24.0" w x 26.7" d	2' Protector XVS	48/22
3908401	36.0" w x 26.7" d	3' Protector XVS, Protector Demonstration Hoods	72/33
3908402	48.0" w x 26.7" d	4' Protector XVS, Protector Work Stations	96/44
3908406	60.0" w x 26.7" d	5' Protector XVS - 29.0" deep models	120/54
3908407	72.0" w x 26.7" d	6' Protector XVS - 29.0" deep models	144/65
3908408	96.0" w x 26.7" d	8' Protector XVS - 29.0" deep models	192/88
3908409	60.0" w x 35.5" d	5' Protector XVS - 35.5" deep models	160/72
3908410	72.0" w x 35.5" d	6' Protector XVS - 35.5" deep models	192/88
3908411	96.0" w x 35.5" d	8' Protector XVS - 35.5" deep models	255/115



Stainless Steel Work Surfaces

Type 304 stainless steel work surfaces are 0.8" thick, have a one inch deep front spill trough and fit dimensions of the Protector XVS Ventilation Stations. Available in 5', 6' and 8' widths.

Catalog #	Dimensions	For use with:	Shipping Wt. lbs./kg
3975500	60.0" w x 26.7" d	5' Protector XVS - 29.0" deep models	140/64
3975501	60.0" w x 35.5" d	5' Protector XVS - 35.5" deep models	180/82
3975600	72.0" w x 26.7" d	6' Protector XVS - 29.0" deep models	170/77
3975601	72.0" w x 35.5" d	6' Protector XVS - 35.5" deep models	220/100
3975800	96.0" w x 26.7" d	8' Protector XVS - 29.0" deep models	240/109
3975801	96.0" w x 35.5" d	8' Protector XVS - 35.5" deep models	290/132



6942003 Work Surface with Sink

For use with Protector Work Stations. Accommodates standard dissecting boards. Molded black solid epoxy is chemical resistant and fire proof. Includes a 10.0" x 14.0" x 6.0" deep molded epoxy sink. Fixtures include a chrome-plated goose-neck faucet with vacuum breaker, two chrome-plated faucet controls and a spray nozzle with hose. **Sink requires a 1.5" diameter drain connection.** Dimensions: 48.0" w x 26.8" d x 1.25" thick. Shipping weight 125 lbs. (57 kg)



Accessories

Protector® XVS Ventilation Stations, Protector® Demonstration Hoods & Protector® Work Stations

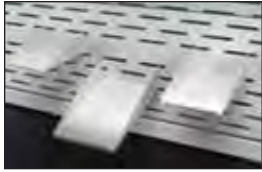

3925000 Utility Shelves

For use with Protector XVS Ventilation Stations and Protector Work Stations. Three shelves attach to the rear baffle perforations to hold items such as a balance printer, utensils and other miscellaneous supplies. The utensil shelf has a scalloped front edge to support scalpels, forceps and other items. Epoxy coated steel. Shipping weight 5 lbs. (2 kg)



3927700 Bottle Holder

For use with Protector XVS Ventilation Stations and Protector Work Stations. Attaches to the rear baffle perforations to hold a squirt bottle or other round container. Epoxy-coated steel. 3" diameter opening. Shipping weight 1 lb. (0.5 kg)



3927800 Tissue Holder

For use with Protector XVS Ventilation Stations and Protector Work Stations. Attaches to the rear baffle perforations to hold tissue wipers in the upside down position. An opening in the bottom of the holder permits wipers to be dispensed from the bottom. Epoxy-coated steel. Shipping weight 1 lb. (0.5 kg)



Fluorescent Task Lights

For use with Protector XVS Ventilations Stations and Protector Demonstration Hoods. May be placed atop the enclosure to enhance illumination of the interior. Include auxiliary electrical receptacle with switch for connection of accessories such as a printer or airflow monitor.

Catalog #	Description	Shipping Wt. lbs./kg
3909200	115 volts, 60 Hz, 10 amps. Includes IEC, three-wire cord with plug.	15/7
3909201*	230 volts, 50 Hz, 10 amps. Includes IEC, three-wire cord. Plug is required (not included).	15/7



5248300 Waste Chute Stopper

For use with 5', 6' and 8' Protector XVS Ventilation Stations, 35.5" deep, with waste chute. When waste chute is not in use, the stopper helps prevent contaminants from escaping from the enclosure through the side wall. Solid rubber. 5" diameter. Shipping weight 1 lb. (0.5 kg)

Flexible Hose for FilterMate Portable Exhauster

For use with the FilterMate Portable Exhauster instead of the flexible polypropylene hose included. 8' length. Include two clamps.

Catalog #	Description	Shipping Wt. lbs./kg
3927500	5" ID, clear urethane, smooth bore with white helix, static dissipative, suitable for pharmaceutical and clean room applications.	3/1
3927600	6" ID, black thermoplastic rubber hose with 6.09" ID cuffs, suitable for pharmaceutical and clean room applications. May be used to duct to the outside.	3/1

3913600 Thimble Connection Kit

For retrofitting FilterMate Portable Exhausters 3970000, 3970020, 3970001, 3970004 and 3970024. Included with FilterMate Portable Exhausters 3970002 and 3970022. Shipping weight 10 lbs. (4 kg)

* International electrical configuration.



Accessories

Protector® XVS Ventilation Stations, Protector® Demonstration Hoods & Protector® Work Stations

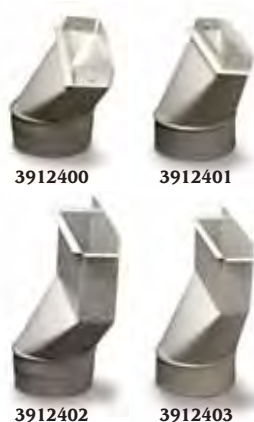

Exhaust Transition Adapters

For use with Protector XVS Ventilation Stations, Protector Demonstration Hoods and Protector Work Stations designed for outside ducting or connected to the FilterMate Portable Exhauster. Epoxy-coated steel.

Catalog #	Description	Shipping Wt. lbs./kg
3912400	Upper Exhaust Transition Adapter, 2.0" x 10.0" rectangular to 5.0" diameter round for connection to 5" ID hose. Included with FilterMate Portable Exhauster.	5/2
3912401	Upper Exhaust Transition Adapter, 2.0" x 10.0" rectangular to 6.0" diameter round for connection to 6" OD duct.	5/2
3912402	Lower Exhaust Transition Adapter, 2.0" x 10.0" rectangular to 5.0" diameter round for connection to 5" ID hose. Included with Protector Demonstration Hood System.	5/2
3912403	Lower Exhaust Transition Adapter, 2.0" x 10.0" rectangular to 6.0" diameter round for connection to 6" OD duct.	5/2

Ductwork

Catalog #	Description	Equivalent Resistance†	Shipping Wt. lbs./kg
4708600	Thermoplastic Duct, 6.625" OD, 6.250" ID, 10' length	10'	25/11
4708900	Female PVC Duct Coupling, 6" nominal diameter, connects two sections of Thermoplastic Duct	0'	4/2
4708700	90° PVC Elbow, 6" nominal diameter, has belled end connections to directly receive Thermoplastic Duct or Male Duct Coupling	12'	1/0.5
3924000	Manual Exhaust Damper, powder-coated steel, 6" nominal diameter	1'	1/0.5
4724200	Manual Exhaust Damper, PVC, 6" nominal diameter	1'	1/0.5
4861800	Flexible Duct Connection, 7" nominal diameter, for use with 6" nominal diameter duct	1'	8/4
4861700	Blower Transition Adapter, 4.25" x 7.75" rectangle to 6" diameter round	1'	3/1
4722200	Zero Pressure Weathercap, 6" nominal diameter, fits atop Thermoplastic Duct	5'	20/9

† Equivalent resistance is measured in feet of straight duct.



Remote Blowers

A remote blower is required when ducting the Protector XVS Ventilation Station, Protector Demonstration Hood or Protector Work Station to the outside. The direct drive blower has a 1/4 hp TEFC-type motor and overcomes external static pressure of 0.5" at 420 CFM. Housing and impeller are corrosion-resistant, phenolic-coated steel. Blower inlet is 5.94" OD and is sized to accept 6" nominal diameter PVC duct. Blower outlet is 4.25" x 7.38" OD. Dimensions: 14.6" w x 13.5" d x 13.25" high.

Catalog #	Electrical Requirements	Shipping Wt. lbs./kg
4863500	115 volts, 60 Hz, 4.4 amps	35/16
4863501*	115/230 volts, 50 Hz, 5.6/2.8 amps	35/16
7053501**	115 volts, 60 Hz 4.4 amps	40/18

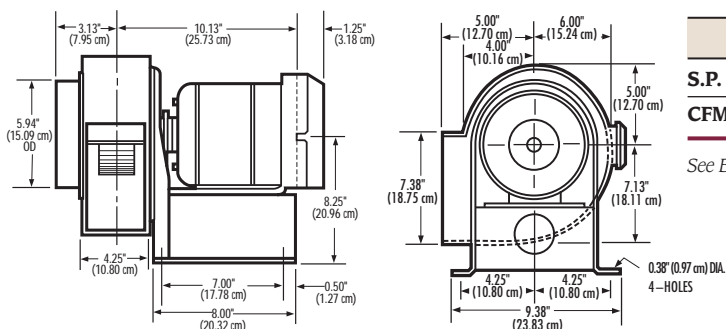

CFM @ Static Pressure - Inches of H₂O

S.P.	0.0"	0.125"	0.25"	0.50"	0.75"	0.87"
CFM	595	560	515	420	300	167

See Blower Booklet for more information.

* International electrical configuration. **Explosion-proof



Accessories

Protector® XVS Ventilation Stations, Protector® Demonstration Hoods & Protector® Work Stations

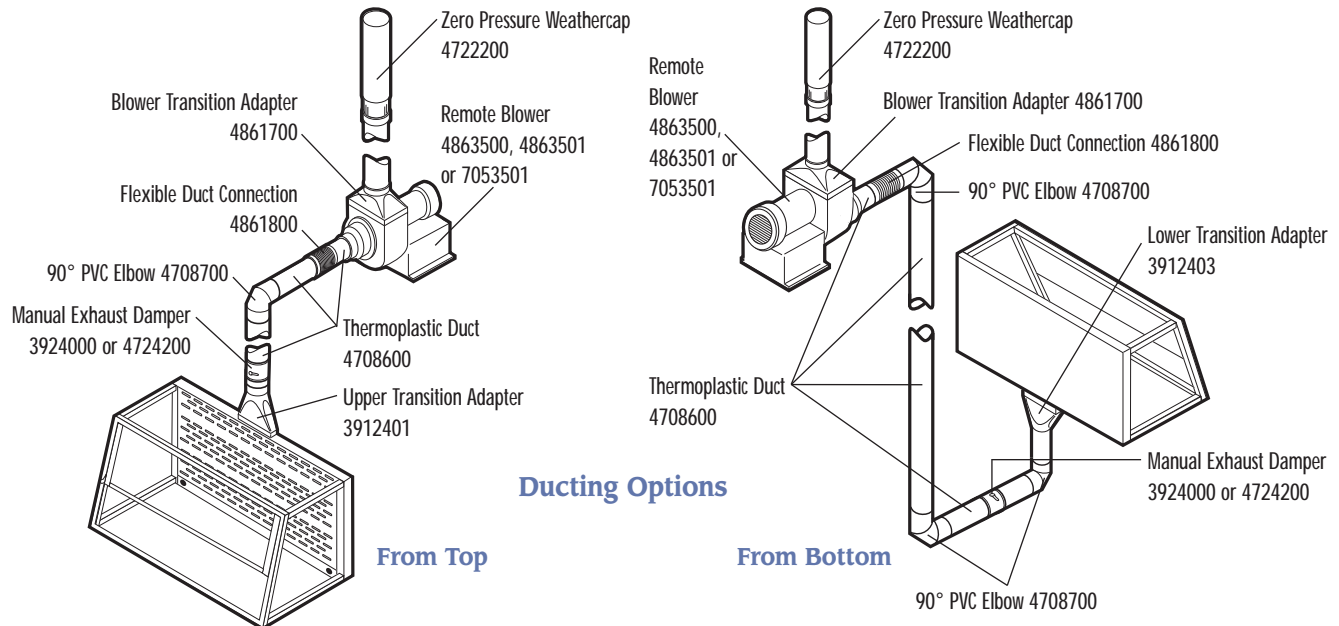

Ducting Options



Guardian™ 1000 Digital Airflow Monitors

Mount atop Protector XVS Ventilation Stations, Protector Demonstration Hoods and Protector Work Stations in factory-prepared location. Monitor and alert the operator to low airflow conditions. Include face plate with circuit board, electrical power pack, airflow hose, flow hose adapter and glacier white epoxy-coated steel casing. LCD displays actual airflow in fpm or m/sec from 0 to 999 fpm (0 to 5.0 m/s). A audible/visual alarm alerts user to sustained low velocity condition. Calibration instructions displayed on LCD. LED lights display red for alarm, yellow for caution, green for normal. Include temperature-compensated sensor, external alarm, RS-232 port, night setback and alarm mute functions. UL and CE listed.

Catalog #	Electrical Requirements	Shipping Wt. lbs./kg
3908800	115 volts, 60 Hz	10/4.5
3908801*	230 volts, 50 Hz	10/4.5



Guardian™ 500 Airflow Monitors

Mount atop Protector XVS Ventilation Stations, Protector Demonstration Hoods and Protector Work Stations in factory-prepared location. Include face plate with circuit board, electrical power pack, tubing, airflow tube adapter and glacier white epoxy-coated steel casing. From the monitor's face plate, the user can easily select and calibrate a setpoint between 30 and 250 fpm using a velocity meter and a screwdriver. A green LED glows to indicate "safe" when airflow is greater than the low setpoint. A red LED flashes to indicate "low" when airflow is below the low setpoint. An amber LED flashes when the sash is raised above the maximum safe working opening. An audible alarm sounds (and can be muted) when under "low" and "sash high" conditions. Include night setback, external alarm and alarm mute functions.

Catalog #	Electrical Requirements	Shipping Wt. lbs./kg
3944700	115 volts, 60 Hz	10/4.5
3944701*	230 volts, 50 Hz	10/4.5



8026000 Cart for Protector Demonstration Hoods

Provides mobile support for Protector Demonstration Hoods and 3' Protector XVS Ventilation Stations. Glacier white epoxy-coated tubular steel with black 1" thick solid epoxy dished work surface, handle bar, bottom shelf and 4" diameter toe-locking casters. Supports loads up to 400 pounds. Cart is included with Protector Demonstration Hood Systems 3945000, 3945001, 3945020 and 3945021. Dimensions: 39.0" w x 31.9" d x 36.0" h. Shipping weight 50 lbs. (23 kg)

* International electrical configuration



Canopy Hoods



Canopy Hood 4799000. Blower and ductwork must be ordered separately.

The Canopy Hood is specifically designed to vent non-toxic materials such as heat, steam and odors from large or bulky apparatus such as ovens, steam baths and autoclaves. The hood may be installed on a wall or suspended from the ceiling for peninsular and corner locations. **For most efficient performance, the hood should be installed no more than 12" above the equipment to be ventilated.** Coupled with a blower and ductwork, the Canopy Hood can operate at a wide range of exhaust rates.

Features:

- Glacier white, dry powder epoxy-coated steel construction.
- Integral baffle.
- Fully assembled.
- Include mounting hardware for installation on wall or suspended from ceiling. **Threaded rod is required for suspension from ceiling.**

Both models require (not included):

- **Remote Blower.** See back pocket.
- **Ductwork.** See back pocket.

Nominal Width	Catalog Number	Shipping Weight lbs./kg
4 Feet	4799000	140/64
6 Feet	7099000	205/93

4' Canopy Hood 4799000

CFM at Static Pressure - Inches H₂O

0.12"	0.19"	0.22"	0.36"	0.39"	0.73"	2.45"
325	450	488	650	675	975	1950

6' Canopy Hood 7099000

CFM at Static Pressure - Inches H₂O

0.17"	0.24"	0.31"	0.45"	0.49"	0.89"	2.50"
425	550	638	825	850	1275	2550

Dimensional Data

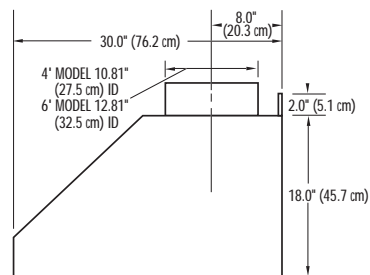

SIDE

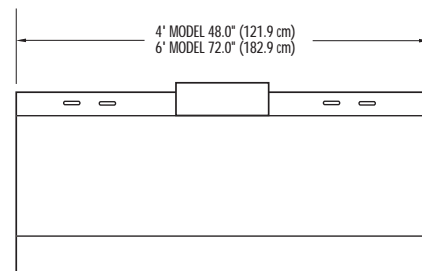

FRONT

Contact Labconco at **800-821-5525** or **816-333-8811** for blower sizing assistance.



SpillStopper™ Work Surfaces

SpillStopper Work Surface 9847100 for use with 4' Protector Premier and XL Laboratory Hoods

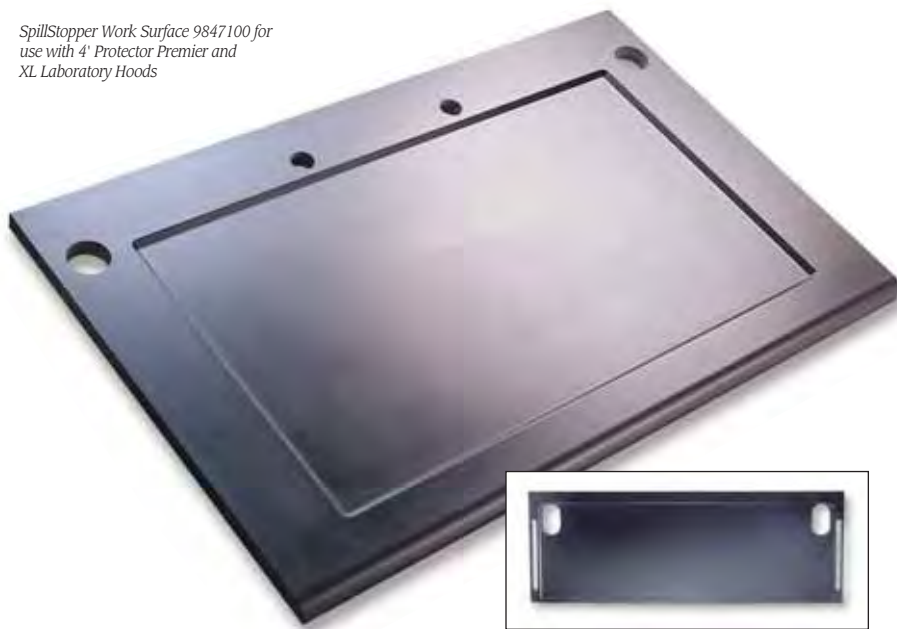

Surface 6986603 for use with 6' Protector ClassMate Laboratory Hoods. See page 103 for Ordering Information and Dimensional Data.

Features:

- Molded from a special formulation of corrosion-resistant epoxy resins.
- Dished and contoured to conform to the interior liner of Protector Laboratory Hoods.
- Front edge has a large radius to aerodynamically direct airflow into the hood.
- Pre-drilled 1.5" diameter holes for venting and 2.5" diameter holes for plumbing passthrough.
- May be ordered with a pre-cut 6" x 3" oval cupsink cutout. Cupsink is sold separately. See page 104.

Contact Labconco at **800-821-5525** or **816-333-8811** for ordering information on work surfaces with pre-drilled cutouts for fixtures, electrical receptacles or larger sinks.

Dimensional Data

SpillStopper Work Surfaces for Use with Protector Premier, XStream, XL and XLE Laboratory Hoods

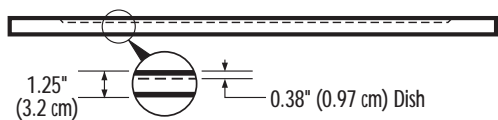
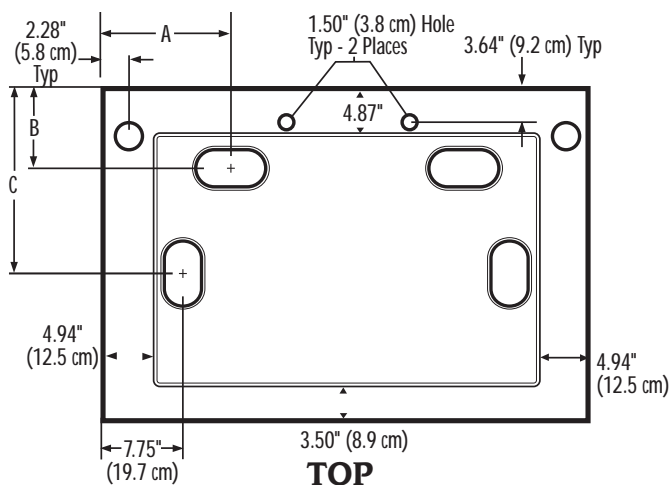

Hood	Work Surface Depth	A	B	C	Radius Front Edge
Premier, XL	30.00"	9.50" (24.1 cm)	5.81" (14.8 cm)	20.00" (50.8 cm)	1.00" (2.5 cm)
XL	36.00"	12.50" (31.8 cm)	8.50" (21.6 cm)	20.00" (50.8 cm)	1.00" (2.5 cm)
XL	42.00"	12.50" (31.8 cm)	8.50" (21.6 cm)	16.12" (40.9 cm)	1.00** (2.5 cm)
XStream	36.00"	12.50" (31.8 cm)	11.50" (29.2 cm)	20.00" (50.8 cm)	1.00" (2.5 cm)
XLE	33.50"	12.50" (31.8 cm)	8.50" (21.6 cm)	20.00" (50.8 cm)	0.25" (0.6 cm)

* Contact Labconco for availability.



SpillStopper™ Work Surfaces

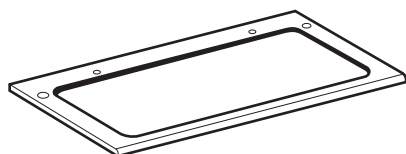

Oval Cupsink Cutout
Left Rear

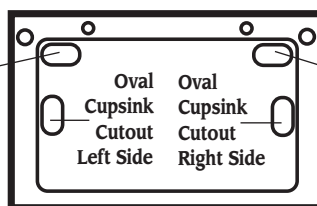

Oval Cupsink Cutout
Right Rear

For use with Protector® Premier™ and XL Laboratory Hoods with 24" interior depth

Catalog #	Description	Shipping Wt. lbs./kg
9847100	4' w x 30" d, no cutouts	110/50
9847101	4' w x 30" d, cupsink cutout, left rear	110/50
9847102	4' w x 30" d, cupsink cutout, right rear	110/50
9847103*	4' w x 30" d, cupsink cutout, left side	110/50
9847104*	4' w x 30" d, cupsink cutout, right side	110/50
9847105	4' w x 30" d, cupsink cutouts, left and right rear	110/50
9847200	5' w x 30" d, no cutouts	150/68
9847201	5' w x 30" d, cupsink cutout, left rear	150/68
9847202	5' w x 30" d, cupsink cutout, right rear	150/68
9847203*	5' w x 30" d, cupsink cutout, left side	150/68
9847204*	5' w x 30" d, cupsink cutout, right side	150/68
9847205	5' w x 30" d, cupsink cutouts, left and right rear	150/68
9847300	6' w x 30" d, no cutouts	205/93
9847301	6' w x 30" d, cupsink cutout, left rear	205/93
9847302	6' w x 30" d, cupsink cutout, right rear	205/93
9847303*	6' w x 30" d, cupsink cutout, left side	205/93
9847304*	6' w x 30" d, cupsink cutout, right side	205/93
9847305	6' w x 30" d, cupsink cutouts, left and right rear	205/93
9847400	8' w x 30" d, no cutouts	240/109
9847401	8' w x 30" d, cupsink cutout, left rear	240/109
9847402	8' w x 30" d, cupsink cutout, right rear	240/109
9847403*	8' w x 30" d, cupsink cutout, left side	240/109
9847404*	8' w x 30" d, cupsink cutout, right side	240/109
9847405	8' w x 30" d, cupsink cutouts, left and right rear	240/109
9847500†	10' w x 30" d, two pieces, no cutouts	290/132
9847501†	10' w x 30" d, two pieces, cupsink cutout, left rear	290/132
9847502†	10' w x 30" d, two pieces, cupsink cutout, right rear	290/132
9847503*†	10' w x 30" d, two pieces, cupsink cutout, left side	290/132
9847504*†	10' w x 30" d, two pieces, cupsink cutout, right side	290/132
9847505†	10' w x 30" d, two pieces, cupsink cutouts, left and right rear	290/132
9847600†	12' w x 30" d, two pieces, no cutouts	370/168
9847601†	12' w x 30" d, two pieces, cupsink cutout, left rear	370/168
9847602†	12' w x 30" d, two pieces, cupsink cutout, right rear	370/168
9847603*†	12' w x 30" d, two pieces, cupsink cutout, left side	370/168
9847604*†	12' w x 30" d, two pieces, cupsink cutout, right side	370/168
9847605†	12' w x 30" d, two pieces, cupsink cutouts, left and right rear	370/168
9847700†	16' w x 30" d, three pieces, no cutouts	480/218
9847701†	16' w x 30" d, three pieces, cupsink cutout, left rear	480/218
9847702†	16' w x 30" d, three pieces, cupsink cutout, right rear	480/218
9847703*†	16' w x 30" d, three pieces, cupsink cutout, left side	480/218
9847704*†	16' w x 30" d, three pieces, cupsink cutout, right side	480/218
9847705†	16' w x 30" d, three pieces, cupsink cutouts, left and right rear	480/218

For use with Protector® XL™ Laboratory Hoods with 30" interior depth

Catalog #	Description	Shipping Wt. lbs./kg
9847800	4' w x 36" d, cupsink cutout, no cutouts	120/54
9847801	4' w x 36" d, cupsink cutout, left rear	120/54
9847802	4' w x 36" d, cupsink cutout, right rear	120/54
9847803*	4' w x 36" d, cupsink cutout, left side	120/54
9847804*	4' w x 36" d, cupsink cutout, right side	120/54
9847805	4' w x 36" d, cupsink cutouts, left and right rear	120/54
9847900	5' w x 36" d, no cutouts	160/73
9847901	5' w x 36" d, cupsink cutout, left rear	160/73
9847902	5' w x 36" d, cupsink cutout, right rear	160/73
9847903*	5' w x 36" d, cupsink cutout, left side	160/73
9847904*	5' w x 36" d, cupsink cutout, right side	160/73
9847905	5' w x 36" d, cupsink cutouts, left and right rear	160/73
9848000	6' w x 36" d, no cutouts	220/100
9848001	6' w x 36" d, cupsink cutout, left rear	220/100
9848002	6' w x 36" d, cupsink cutout, right rear	220/100
9848003*	6' w x 36" d, cupsink cutout, left side	220/100
9848004*	6' w x 36" d, cupsink cutout, right side	220/100
9848005	6' w x 36" d, cupsink cutouts, left and right rear	220/100
9848100	8' w x 36" d, no cutouts	250/113
9848101	8' w x 36" d, cupsink cutout, left rear	250/113
9848102	8' w x 36" d, cupsink cutout, right rear	250/113
9848103*	8' w x 36" d, cupsink cutout, left side	250/113
9848104*	8' w x 36" d, cupsink cutout, right side	250/113
9848105	8' w x 36" d, cupsink cutouts, left and right rear	250/113
9848200†	10' w x 36" d, two pieces, no cutouts	320/145
9848201†	10' w x 36" d, two pieces, cupsink cutout, left rear	320/145
9848202†	10' w x 36" d, two pieces, cupsink cutout, right rear	320/145
9848203*†	10' w x 36" d, two pieces, cupsink cutout, left side	320/145
9848204*†	10' w x 36" d, two pieces, cupsink cutout, right side	320/145
9848205†	10' w x 36" d, two pieces, cupsink cutouts, left and right rear	320/145
9848300†	12' w x 36" d, two pieces, no cutouts	440/200
9848301†	12' w x 36" d, two pieces, cupsink cutout, left rear	440/200
9848302†	12' w x 36" d, two pieces, cupsink cutout, right rear	440/200
9848303*†	12' w x 36" d, two pieces, cupsink cutout, left side	440/200
9848304*†	12' w x 36" d, two pieces, cupsink cutout, right side	440/200
9848305†	12' w x 36" d, two pieces, cupsink cutouts, left and right rear	440/200
9848400†	16' w x 36" d, three pieces, no cutouts	500/228
9848401†	16' w x 36" d, three pieces, cupsink cutout, left rear	500/228
9848402†	16' w x 36" d, three pieces, cupsink cutout, right rear	500/228
9848403*†	16' w x 36" d, three pieces, cupsink cutout, left side	500/228
9848404*†	16' w x 36" d, three pieces, cupsink cutout, right side	500/228
9848405†	16' w x 36" d, three pieces, cupsink cutouts, left and right rear	500/228

* Not for use with Protector Solvent Storage Cabinets † Requires field assembly



SpillStopper™ Work Surfaces

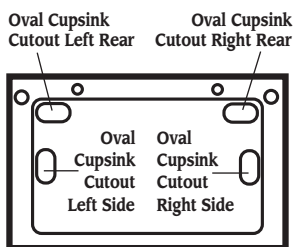
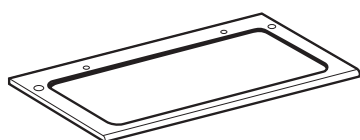

For use with Protector® XL™ Laboratory Hoods with 36" interior depth

Catalog #	Description	Shipping Wt. lbs./kg
9848500	4' w x 42" d, no cutouts	140/64
9848501	4' w x 42" d, cupsink cutout, left rear	140/64
9848502	4' w x 42" d, cupsink cutout, right rear	140/64
9848503*	4' w x 42" d, cupsink cutout, left side	140/64
9848504*	4' w x 42" d, cupsink cutout, right side	140/64
9848505	4' w x 42" d, cupsink cutouts, left and right rear	140/64
9848600	5' w x 42" d, no cutouts	180/82
9848601	5' w x 42" d, cupsink cutout, left rear	180/82
9848602	5' w x 42" d, cupsink cutout, right rear	180/82
9848603*	5' w x 42" d, cupsink cutout, left side	180/82
9848604*	5' w x 42" d, cupsink cutout, right side	180/82
9848605	5' w x 42" d, cupsink cutouts, left and right rear	180/82
9848700	6' w x 42" d, no cutouts	250/113
9848701	6' w x 42" d, cupsink cutout, left rear	250/113
9848702	6' w x 42" d, cupsink cutout, right rear	250/113
9848703*	6' w x 42" d, cupsink cutout, left side	250/113
9848704*	6' w x 42" d, cupsink cutout, right side	250/113
9848705	6' w x 42" d, cupsink cutouts, left and right rear	250/113
9848800	8' w x 42" d, no cutouts	290/132
9848801	8' w x 42" d, cupsink cutout, left rear	290/132
9848802	8' w x 42" d, cupsink cutout, right rear	290/132
9848803*	8' w x 42" d, cupsink cutout, left side	290/132
9848804*	8' w x 42" d, cupsink cutout, right side	290/132
9848805	8' w x 42" d, cupsink cutouts, left and right rear	290/132
9848900†	10' w x 42" d, two pieces, no cutouts	350/159
9848901†	10' w x 42" d, two pieces, cupsink cutout, left rear	350/159
9848902†	10' w x 42" d, two pieces, cupsink cutout, right rear	350/159
9848903*†	10' w x 42" d, two pieces, cupsink cutout, left side	350/159
9848904*†	10' w x 42" d, two pieces, cupsink cutout, right side	350/159
9848905†	10' w x 42" d, two pieces, cupsink cutouts, left and right rear	350/159
9849000†	12' w x 42" d, three pieces, no cutouts	480/218
9849001†	12' w x 42" d, three pieces, cupsink cutout, left rear	480/218
9849002†	12' w x 42" d, three pieces, cupsink cutout, right rear	480/218
9849003*†	12' w x 42" d, three pieces, cupsink cutout, left side	480/218
9849004*†	12' w x 42" d, three pieces, cupsink cutout, right side	440/218
9849005†	12' w x 42" d, three pieces, cupsink cutouts, left and right rear	480/218
9849100†	16' w x 42" d, three pieces, no cutouts	550/249
9849101†	16' w x 42" d, three pieces, cupsink cutout, left rear	550/249
9849102†	16' w x 42" d, three pieces, cupsink cutout, right rear	550/249
9849103*†	16' w x 42" d, three pieces, cupsink cutout, left side	550/249
9849104*†	16' w x 42" d, three pieces, cupsink cutout, right side	550/249
9849105†	16' w x 42" d, three pieces, cupsink cutouts, left and right rear	550/249

For use with Protector® XStream® Laboratory Hoods

Catalog #	Description	Shipping Wt. lbs./kg
9849600	4' w x 36" d, no cutouts	120/54
9849601	4' w x 36" d, cupsink cutout, left rear	120/54
9849602	4' w x 36" d, cupsink cutout, right rear	120/54
9849603*	4' w x 36" d, cupsink cutout, left side	120/54
9849604*	4' w x 36" d, cupsink cutout, right side	120/54
9849605	4' w x 36" d, cupsink cutouts, left and right rear	120/54
9849700	5' w x 36" d, no cutouts	160/73
9849701	5' w x 36" d, cupsink cutout, left rear	160/73
9849702	5' w x 36" d, cupsink cutout, right rear	160/73
9849703*	5' w x 36" d, cupsink cutout, left side	160/73
9849704*	5' w x 36" d, cupsink cutout, right side	160/73
9849705	5' w x 36" d, cupsink cutouts, left and right rear	160/73
9849800	6' w x 36" d, no cutouts	220/100
9849801	6' w x 36" d, cupsink cutout, left rear	220/100
9849802	6' w x 36" d, cupsink cutout, right rear	220/100
9849803*	6' w x 36" d, cupsink cutout, left side	220/100
9849804*	6' w x 36" d, cupsink cutout, right side	220/100
9849805	6' w x 36" d, cupsink cutouts, left and right rear	220/100
9849900	8' w x 36" d, no cutouts	250/113
9849901	8' w x 36" d, cupsink cutout, left rear	250/113
9849902	8' w x 36" d, cupsink cutout, right rear	250/113
9849903*	8' w x 36" d, cupsink cutout, left side	250/113
9849904*	8' w x 36" d, cupsink cutout, right side	250/113
9849905	8' w x 36" d, cupsink cutouts, left and right rear	250/113

For use with Protector® XLE™ Laboratory Hoods

Catalog #	Description	Shipping Wt. lbs./kg
9969400	4' w x 33.5" d, no cutouts	115/52
9969401	4' w x 33.5" d, cupsink cutout, left rear	115/52
9969402	4' w x 33.5" d, cupsink cutout, right rear	115/52
9969403*	4' w x 33.5" d, cupsink cutout, left side	115/52
9969404*	4' w x 33.5" d, cupsink cutout, right side	115/52
9969405*	4' w x 33.5" d, cupsink cutouts, left and right rear	115/52
9969500	5' w x 33.5" d, no cutouts	150/68
9969501	5' w x 33.5" d, cupsink cutout, left rear	150/68
9969502	5' w x 33.5" d, cupsink cutout, right rear	150/68
9969503*	5' w x 33.5" d, cupsink cutout, left side	150/68
9969504*	5' w x 33.5" d, cupsink cutout, right side	150/68
9969505*	5' w x 33.5" d, cupsink cutouts, left and right rear	150/68
9969600	6' w x 33.5" d, no cutouts	205/93
9969601	6' w x 33.5" d, cupsink cutout, left rear	205/93
9969602	6' w x 33.5" d, cupsink cutout, right rear	205/93
9969603*	6' w x 33.5" d, cupsink cutout, left side	205/93
9969604*	6' w x 33.5" d, cupsink cutout, right side	205/93
9969605*	6' w x 33.5" d, cupsink cutouts, left and right rear	205/93
9969700	7' w x 33.5" d, no cutouts	220/100
9969701	7' w x 33.5" d, cupsink cutout, left rear	220/100
9969702	7' w x 33.5" d, cupsink cutout, right rear	220/100
9969703*	7' w x 33.5" d, cupsink cutout, left side	220/100
9969704*	7' w x 33.5" d, cupsink cutout, right side	220/100
9969705*	7' w x 33.5" d, cupsink cutouts, left and right rear	220/100
9969800	8' w x 33.5" d, no cutouts	235/107
9969801	8' w x 33.5" d, cupsink cutout, left rear	235/107
9969802	8' w x 33.5" d, cupsink cutout, right rear	235/107
9969803*	8' w x 33.5" d, cupsink cutout, left side	235/107
9969804*	8' w x 33.5" d, cupsink cutout, right side	235/107
9969805*	8' w x 33.5" d, cupsink cutouts, left and right rear	235/107

* Not for use with Protector Solvent Storage Cabinets † Requires field assembly



SpillStopper™ Work Surfaces & Accessories

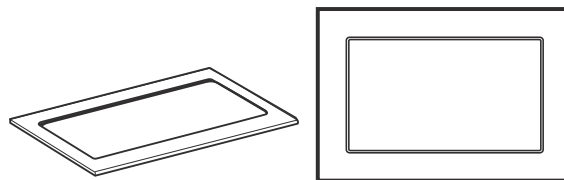
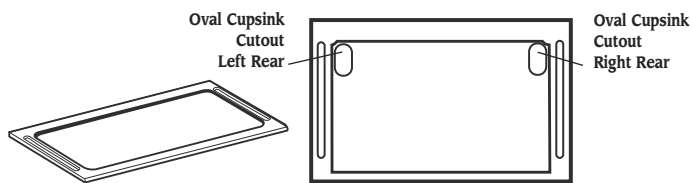

For use with Protector® ClassMate® Laboratory Hoods

Catalog #	Description	Shipping Wt. lbs./kg
6986400	4' w x 25.9" d, no cutouts	110/50
6986401	4' w x 25.9" d, cupsink cutout, left rear	110/50
6986402	4' w x 25.9" d, cupsink cutout, right rear	110/50
6986403	4' w x 25.9" d, cupsink cutouts, left and right rear	110/50
6986500	5' w x 25.9" d, no cutouts	150/68
6986501	5' w x 25.9" d, cupsink cutout, left rear	150/68
6986502	5' w x 25.9" d, cupsink cutout, right rear	150/68
6986503	5' w x 25.9" d, cupsink cutouts, left and right rear	150/68
6986600	6' w x 25.9" d, no cutouts	205/93
6986601	6' w x 25.9" d, cupsink cutout, left rear	205/93
6986602	6' w x 25.9" d, cupsink cutout, right rear	205/93
6986603	6' w x 25.9" d, cupsink cutouts, left and right rear	205/93

For use with Protector® Pass-Through Laboratory Hoods

Catalog #	Description	Shipping Wt. lbs./kg
9972400	4' w x 30" d, no cutouts	110/50
9972500	5' w x 30" d, no cutouts	150/68
9972600	6' w x 30" d, no cutouts	205/93

Dimensional Data

SpillStopper Work Surfaces for Use with Protector ClassMate Laboratory Hoods

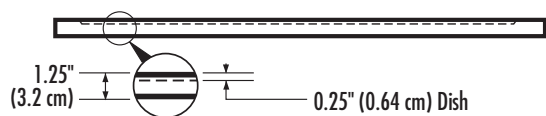
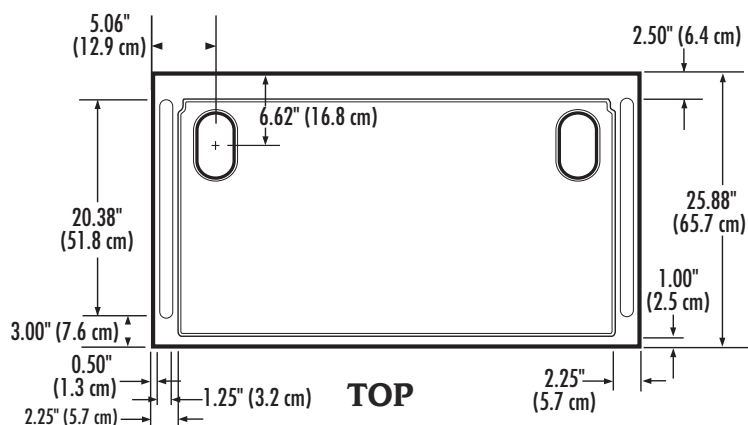

FRONT



SIDE

Dimensional Data

SpillStopper Work Surfaces for Use with Protector Pass-Through Laboratory Hoods

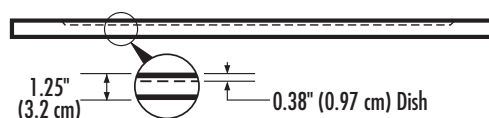
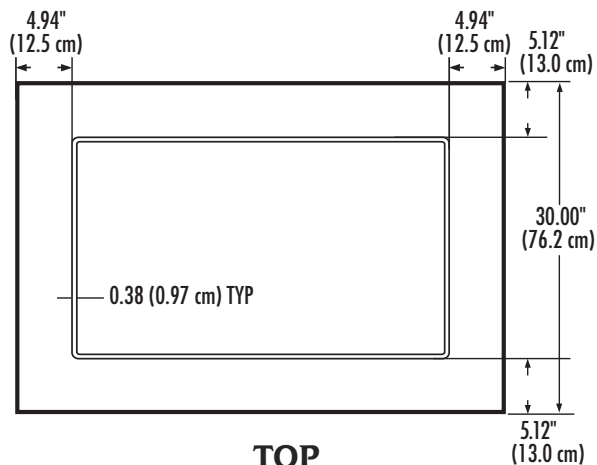

FRONT



SIDE



Flat Work Surfaces & Accessories

Flat Solid Epoxy Work Surfaces

For Use with Labconco Enclosures including Fiberglass 30 and Basic Laboratory Hoods and Fume Adsorbers*

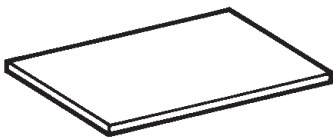

Catalog #	Description	Shipping Wt. lbs./kg
4882806	30" w x 30" d x 1.25" thick, no cutouts	86/39
4882805	36" w x 30" d x 1.25" thick, no cutouts	90/41
4882803	48" w x 30" d x 1.25" thick, no cutouts	110/50
4882804	72" w x 30" d x 1.25" thick, no cutouts	205/93

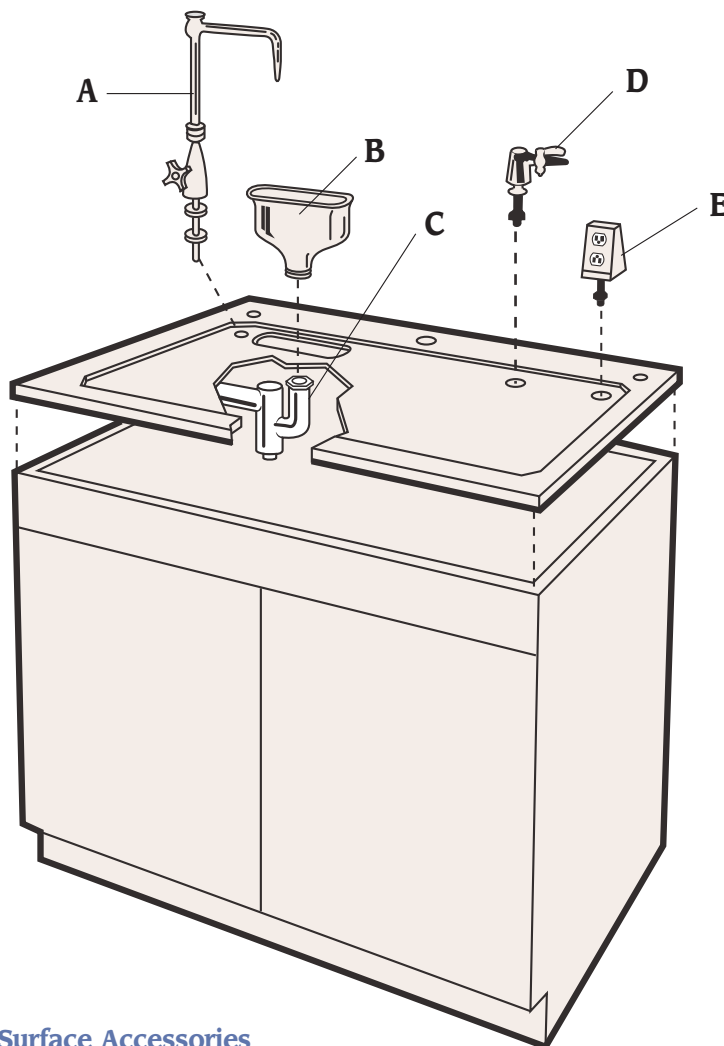

SpillStopper™ & Flat Work Surface Accessories

- (A) **4005100 Cold Water Faucet with Rigid Gooseneck** Factory-drilled mounting hole in work surface is required. Shipping weight 4 lbs. (1.8 kg)
- (A) **4005900 Cold Water Faucet with Rigid Gooseneck and Vacuum Breaker** Factory-drilled mounting hole in work surface is required. Shipping weight 4 lbs. (1.8 kg)
- (B) **4005200 Oval Polypropylene Cupsink** Mounts in work surface with cupsink cutout. 3" x 6". 1.5" NPSM** thread. Shipping weight 4 lbs. (1.8 kg)
4005201 Cupsink Cover Black solid epoxy resin cover for oval cupsink cutout. Provides a continuous work surface when a cupsink is not in use. 7.4" wide x 4.4" deep x 0.3" thick (19 x 12 x 0.8 cm). Shipping weight 2 lbs. (0.9 kg)
- (C) **4005400 Trap, Lead** 1.5" diameter drum with coupling nut. For use with cupsink. Shipping weight 10 lbs. (4.5 kg)
- (C) **1432600 Trap, PVC** 1.5" diameter drum with coupling nut. For use with cupsink. Shipping weight 10 lbs. (4.5 kg)
1361100 Sepia Bronze-Coated Cold and Hot Water Mixing Faucet with Swivel Gooseneck Not shown. Factory-drilled mounting hole in work surface is required. Shipping weight 4 lbs. (1.8 kg)
1361200 Chrome-Plated Cold and Hot Water Mixing Faucet with Swivel Gooseneck Not shown. Factory-drilled mounting hole in work surface is required. Shipping weight 4 lbs. (1.8 kg)
- (D) **4005000 Service Fixture** Specify air, gas or vacuum. Factory-drilled mounting hole in work surface is required. Shipping weight 4 lbs. (1.8 kg)
- (E) **4005800 Electrical Receptacle** Pedestal-type, 115 volt, 15 amp duplex. Factory-drilled mounting hole in work surface is required. Shipping weight 4 lbs. (1.8 kg)

* Basic Hoods and Fume Adsorbers are not as wide or as deep as the work surfaces that support them.

** National Pipe Straight Mechanical



Base Stands & Storage Cabinets

Selection Guide

Base stands and cabinets may be mixed or matched so that their total width equals the width of the Labconco fume hood or enclosure they support.*

Base Stands

Width	Telescoping w/Fixed Feet	w/Casters	Electric 115 Volts, 60 Hz	Hydraulic Lift Electric 230 volts, 50 Hz**	Manual	ADA
24"	3746700	3746701	—	—	—	—
36"	3746701	3746711	3780300	3780303	3780400	—
48"	3746702	3746712	3780301	3780304	3780401	9838600
60"	3746703	—	—	—	—	—
72"	3746704	3746714	3780302	3780305	3780402	—

Storage Cabinets

Width/Description	Acid			Solvent		
	Dual Doors	Right Hinge	Left Hinge	Dual Doors	Right Hinge	Left Hinge
48"	9901000	—	—	9902000	—	—
36"	9901100	—	—	9902100	—	—
30"	9901200	—	—	9902200	—	—
24"	—	9901300	9901500	—	9902300	9902400
18"	—	9901400	9901600	—	—	—
48" w/self-closing doors	—	—	—	9903000	—	—
36" w/self-closing doors	—	—	—	9903100	—	—
30" w/self-closing doors	—	—	—	9903200	—	—
24" w/self-closing doors	—	—	—	—	9903300	9903400
24" ADA	—	9905000	9905200	—	9906000	9906100
24" ADA w/ self-closing doors	—	—	—	—	9906200	9906300
18" ADA	—	9905100	9905300	—	—	—

Width/Description	Standard			Vacuum Pump		
	Dual Doors	Right Hinge	Left Hinge	Dual Doors	Right Hinge	Left Hinge
48"	9900000	—	—	—	—	—
36"	9900100	—	—	—	—	—
30"	9900200	—	—	—	—	—
24"	—	9900300	9900600	—	—	—
18"	—	9900400	9900700	—	9907000	9907100
12"	—	9900500	9900800	—	—	—
24" ADA	—	9904000	9904300	—	—	—
18" ADA	—	9904100	9904400	—	—	—
12" ADA	—	9904200	9904500	—	—	—

* Basic Laboratory Hoods are not as wide or as deep as the base cabinets, stands and work surfaces that support them.

** International electrical configuration



Protector® Acid Storage Cabinets



Protector Acid Storage Cabinet 9901100 with dual doors, 36" wide.



The interior of the Protector Acid Storage Cabinet is lined with polyethylene for corrosion resistance.

Protector Acid Storage Cabinets support Labconco fume hoods and enclosures and safely store and vent acids and other corrosive liquids.

Features:

- Support all Labconco benchtop fume hoods. **Work surface is required.**
- Support loads up to 800 pounds.
- Durable epoxy-coated steel construction with corrosion-resistant polyethylene-lined interior.
- Attractive glacier white exterior complements laboratory casework and Labconco fume hoods.
- Manual-closing, non-locking door(s).*
- Include vacuum-formed PVC liner tray.
- Include two rear vent connection cutouts for venting the cabinet into a fume hood. Vent Kit 3591100 is sold separately. See page 107.
- Include four leveling feet and one 8" filler panel to increase cabinet depth from 22" to 30".
- Work surface and interior shelf kits are sold separately. See pages 100-104 and 107.

Dimensional Data

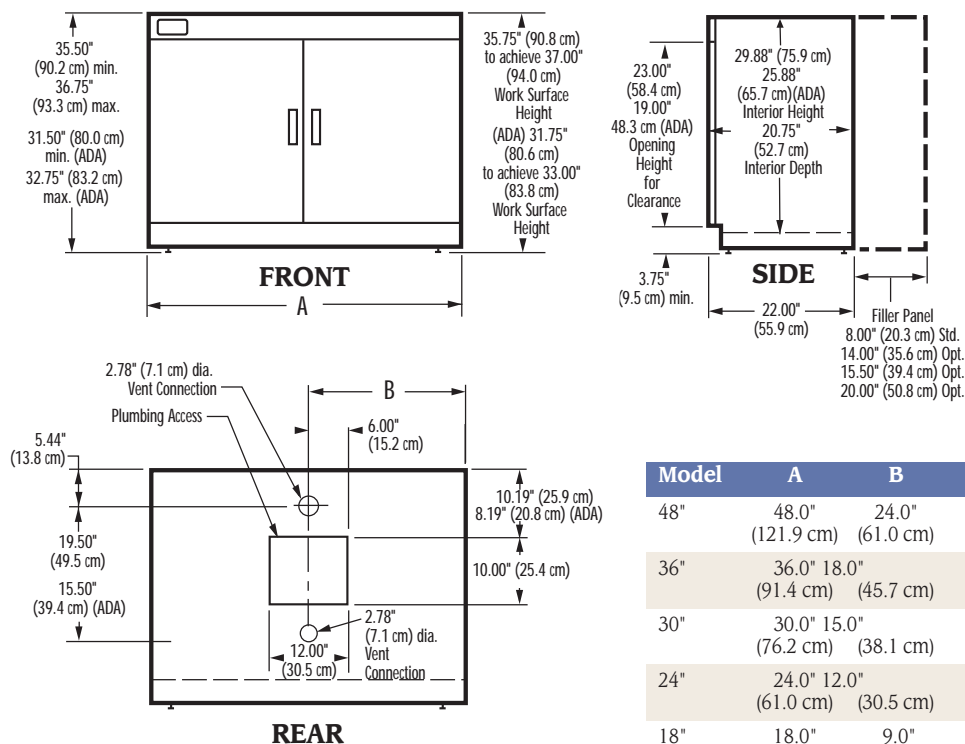

* Contact Labconco for ordering information on Protector Acid Storage Cabinets with locking doors.





Model	A	B
48"	48.0" (121.9 cm)	24.0" (61.0 cm)
36"	36.0" (91.4 cm)	18.0" (45.7 cm)
30"	30.0" (76.2 cm)	15.0" (38.1 cm)
24"	24.0" (61.0 cm)	12.0" (30.5 cm)
18"	18.0"	9.0"
24" ADA	24.0"	12.0"
18" ADA	18.0"	9.0"

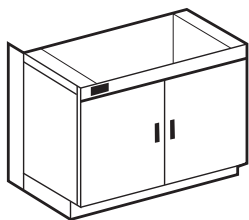

Protector® Acid Storage Cabinets

Ordering Information



Catalog #	Cabinet Dimensions (w x d x h)	Depth with filler panel	Door(s)	Shipping Wt. lbs./kg
9901000	48" x 22" x 35.5" to 36.75" (122 x 56 x 90 to 93 cm)	30" (76 cm)	Dual	260/118
9901100	36" x 22" x 35.5" to 36.75" (91 x 56 x 90 to 93 cm)	30" (76 cm)	Dual	180/82
9901200	30" x 22" x 35.5" to 36.75" (76 x 56 x 90 to 93 cm)	30" (76 cm)	Dual	155/70
9901300	24" x 22" x 35.5" to 36.75" (61 x 56 x 90 to 93 cm)	30" (76 cm)	Single Right Hinge	130/59
9901400	18" x 22" x 35.5" to 36.75" (46 x 56 x 90 to 93 cm)	30" (76 cm)	Single Right Hinge	90/41
9901500	24" x 22" x 35.5" to 36.75" (61 x 56 x 90 to 93 cm)	30" (76 cm)	Single Left Hinge	130/59
9901600	18" x 22" x 35.5" to 36.75" (46 x 56 x 90 to 93 cm)	30" (76 cm)	Single Left Hinge	90/41
 9905000	24" x 22" x 31.5" to 32.75" (61 x 56 x 80 to 83 cm)	30" (76 cm)	Single Right Hinge	120/54
 9905100	18" x 22" x 31.5" to 32.75" (46 x 56 x 80 to 83 cm)	30" (76 cm)	Single Right Hinge	85/39
 9905200	24" x 22" x 31.5" to 32.75" (61 x 56 x 80 to 83 cm)	30" (76 cm)	Single Left Hinge	120/54
 9905300	18" x 22" x 31.5" to 32.75" (46 x 56 x 80 to 83 cm)	30" (76 cm)	Single Left Hinge	85/39

Accessories

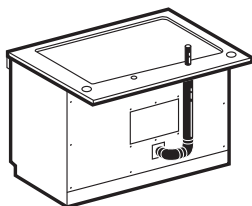

3591100 Vent Kit

Used for venting the Protector Acid Storage Cabinet through the SpillStopper Work Surface and into the fume hood. Includes one plastic vent tube assembly complete with 2" diameter threaded connection locknut,

flexible tubing and vent extension. Shipping weight 5 lbs. (2.3 kg)

Interior Shelf Kits

Include epoxy-coated steel shelf, acid-resistant PVC tray and mounting hardware.

Width	Catalog #	Shipping Wt. lbs./kg
48"	9919000	15/6.8
36"	9919001	12/5.4
30"	9919002	10/4.5
24"	9919003	8/3.6
18"	9919004	7/3.2

Filler Panels

One 8" filler panel is included with each Storage Cabinet to extend cabinet depth to 30" and to enclose the utility chase behind the cabinet. Cabinets supporting hoods with external depths greater than 33.2" require deeper filler panels.

Catalog #	Description	Shipping Wt. lbs./kg
9920306	Filler Panel, 8" deep	10/4.5
9920310	Filler Panel, 14" deep	13/5.9
9920312	Filler Panel, 20" deep	15/6.8
9920301	Filler Panel, 15.5" deep	13/5.9
9920307	ADA Filler Panel, 8" deep	9/4.1
9920311	ADA Filler Panel, 14" deep	12/5.4
9920313	ADA Filler Panel, 20" deep	14/6.4
9920304	ADA Filler Panel, 15.5" deep	12/5.4



Protector® Solvent Storage Cabinets



Protector Solvent Storage Cabinet 9903100 with dual, automatic self-closing/self-latching doors, 36" wide.



Protector Solvent Storage Cabinet 9902200, 30" wide, with dual, manual-closing doors.



Protector Solvent Storage Cabinet 9903200, 36" wide, with dual, automatic self-closing doors.

Protector Solvent Storage Cabinets support Labconco fume hoods and safely store and vent solvents and other flammable liquids.

Features:

- Support all Labconco benchtop fume hoods. **Work surface is required.**
- Support loads up to 800 pounds.
- Durable dual wall epoxy-coated steel construction with 1.5" air gap.
- Attractive glacier white exterior complements laboratory casework and Labconco fume hoods.
- Include key lock. Doors are manual-closing or self-closing/self-latching with sequencing mechanism. Self-closing door(s) close automatically in case of fire when temperature reaches 165° F (74° C).
- Meet National Fire Protection Association (NFPA) 30-2003 Flammable and Combustible Liquids Code Specifications.
- Include epoxy-coated steel interior shelf with five height settings.
- Include two rear vent connections with flame arrestors and closure plugs.
- Include four leveling feet and one 8" filler panel to increase cabinet depth from 22" to 30".
- Work surface is sold separately. See pages 100-104.

Dimensional Data

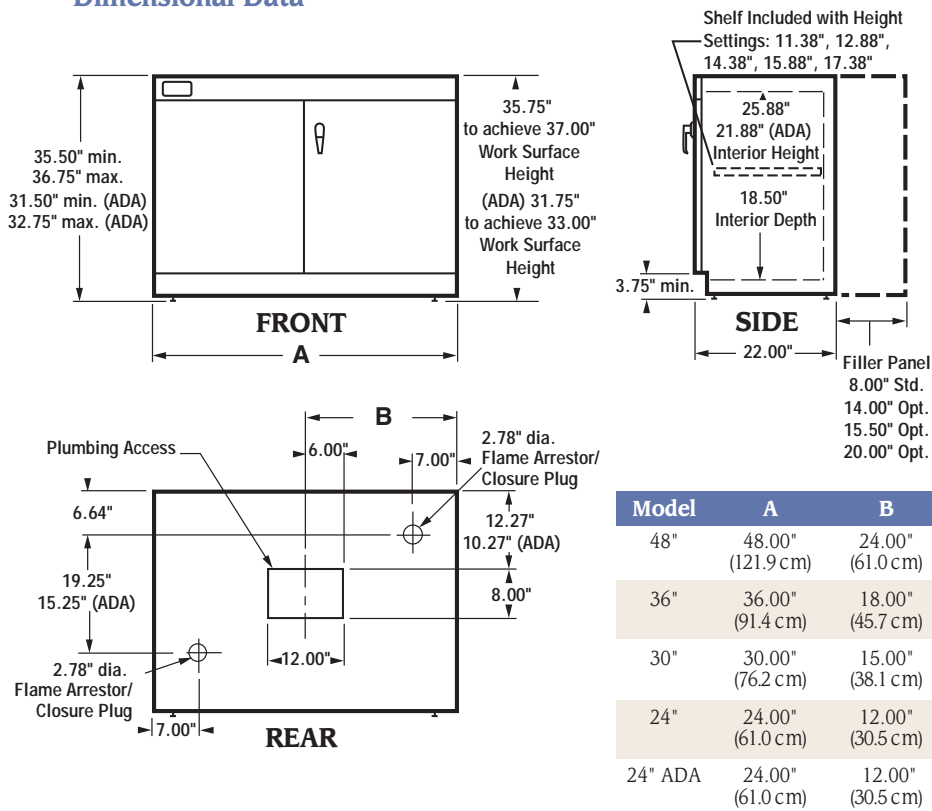





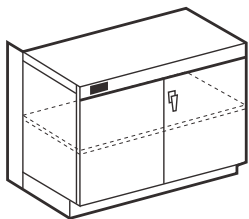

Protector® Solvent Storage Cabinets

Ordering Information



Catalog #	Cabinet Dimensions (w x d x h)	Depth with standard filler panel	Door(s)	Gallon Capacity	Shipping Wt. lbs./kg
9902000*	48" x 22" x 35.5" to 36.75" (122 x 56 x 90 to 93 cm)	30" (76 cm)	Dual Manual	45	260/118
9902100*	36" x 22" x 35.5" to 36.75" (91 x 56 x 90 to 93 cm)	30" (76 cm)	Dual Manual	30	180/82
9902200*	30" x 22" x 35.5" to 36.75" (76 x 56 x 90 to 93 cm)	30" (76 cm)	Dual Manual	25	155/70
9902300	24" x 22" x 35.5" to 36.75" (61 x 56 x 90 to 93 cm)	30" (76 cm)	Single, Right Hinge Manual	20	130/59
9902400	24" x 22" x 35.5" to 36.75" (61 x 56 x 90 to 93 cm)	30" (76 cm)	Single, Left Hinge Manual	20	130/59
 9906000	24" x 22" x 31.5" to 32.75" (61 x 56 x 80 to 83 cm)	30" (76 cm)	Single, Right Hinge Manual	15	120/54
 9906100	24" x 22" x 31.5" to 32.75" (61 x 56 x 80 to 83 cm)	30" (76 cm)	Single, Left Hinge Manual	15	120/54
9903000*	48" x 22" x 35.5" to 36.75" (122 x 56 x 90 to 93 cm)	30" (76 cm)	Dual Self-Closing/Self-Latching	45	260/118
9903100*	36" x 22" x 35.5" to 36.75" (91 x 56 x 90 to 93 cm)	30" (76 cm)	Dual Self-Closing/Self-Latching	30	180/82
9903200*	30" x 22" x 35.5" to 36.75" (76 x 56 x 90 to 93 cm)	30" (76 cm)	Dual Self-Closing/Self-Latching	25	155/70
9903300	24" x 22" x 35.5" to 36.75" (61 x 56 x 90 to 93 cm)	30" (76 cm)	Single, Right Hinge Self-Closing/Self-Latching	20	130/59
9903400	24" x 22" x 35.5" to 36.75" (61 x 56 x 90 to 93 cm)	30" (76 cm)	Single, Left Hinge Self-Closing/Self-Latching	20	130/59
 9906200	24" x 22" x 31.5" to 32.75" (61 x 56 x 80 to 83 cm)	30" (76 cm)	Single, Right Hinge Self-Closing/Self-Latching	15	120/54
 9906300	24" x 22" x 31.5" to 32.75" (61 x 56 x 80 to 83 cm)	30" (76 cm)	Single, Left Hinge Self-Closing/Self-Latching	15	120/54

Accessories

Filler Panels

One 8" filler panel is included with each Storage Cabinet to extend cabinet depth to 30" and to enclose the utility chase behind the cabinet. Cabinets supporting hoods with external depths greater than 33.2" require deeper filler panels.

Catalog #	Description	Shipping Wt. lbs./kg
9920306	Filler Panel, 8" deep	10/4.5
9920310	Filler Panel, 14" deep	13/5.9
9920312	Filler Panel, 20" deep	15/6.8
9920301	Filler Panel, 15.5" deep	13/5.9
9920307	ADA Filler Panel, 8" deep	9/4.1
9920311	ADA Filler Panel, 14" deep	12/5.4
9920313	ADA Filler Panel, 20" deep	14/6.4
9920304	ADA Filler Panel, 15.5" deep	12/5.4

9910000 Solvent Vent Kit

Includes 1.5" diameter metal flexible hose, two hose clamps and 2" NPT x 1.5" slip-fit outlet adapter. Shipping weight 5 lbs. (2.3 kg)

 Cabinet height meets requirements of the ADA.

* Factory Mutual approved



Protector® Standard Storage Cabinets



Protector Standard Storage Cabinet 9904000, 24" wide, ADA height, with right hinge, single door.

Protector Standard Storage Cabinet 9900000, 48" wide, with dual doors.

Protector Standard Storage Cabinets support Labconco fume hoods and may be used for storage of supplies and small laboratory instruments.

Features:

- Support all Labconco benchtop fume hoods. **Work surface is required.**
- Support loads up to 800 pounds.
- Durable epoxy-coated steel construction.
- Attractive glacier white exterior complements laboratory casework and Labconco fume hoods.
- Manual-closing, non-locking door(s).*
- Include four leveling feet and one 8" filler panel to increase cabinet depth from 22" to 30".
- Work surface and interior shelf kits are sold separately. See pages 100-104 and 111.

Dimensional Data

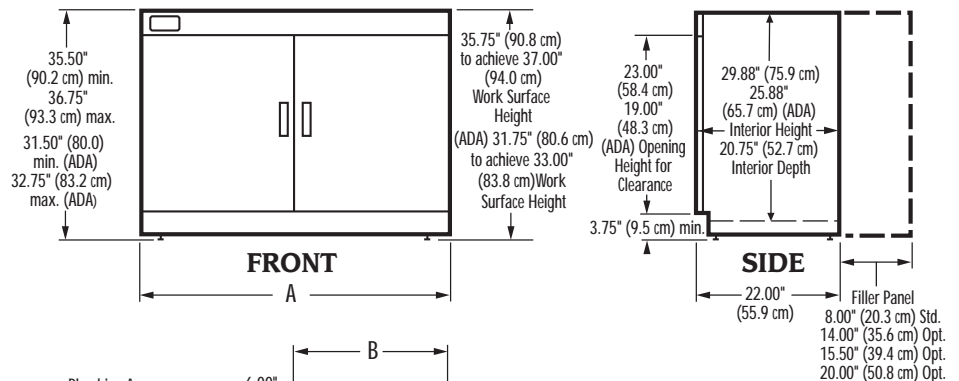

Model	A	B
48"	48.00" (121.9 cm)	24.00" (61.0 cm)
36"	36.00" (91.4 cm)	18.00" (45.7 cm)
30"	30.00" (76.2 cm)	15.00" (38.1 cm)
24"	24.00" (61.0 cm)	12.00" (30.5 cm)
18"	18.00" (45.7 cm)	9.00" (22.9 cm)
12"	12.00" (30.5 cm)	—
24" ADA	24.00" (61.0 cm)	12.00" (30.5 cm)
18" ADA	18.00" (45.7 cm)	9.00" (22.9 cm)
12" ADA	12.00" (30.5 cm)	—







* Contact Labconco for ordering information on Protector Standard Storage Cabinets with locking doors.



Protector® Standard Storage Cabinets

Ordering Information



Catalog #	Cabinet Dimensions (w x d x h)	Depth with standard filler panel	Door(s)	Shipping Wt. lbs./kg
9900000	48" x 22" x 35.5" to 36.75" (122 x 56 x 90 to 93 cm)	30" (76 cm)	Dual	260/118
9900100	36" x 22" x 35.5" to 36.75" (91 x 56 x 90 to 93 cm)	30" (76 cm)	Dual	180/82
9900200	30" x 22" x 35.5" to 36.75" (76 x 56 x 90 to 93 cm)	30" (76 cm)	Dual	155/70
9900300	24" x 22" x 35.5" to 36.75" (61 x 56 x 90 to 93 cm)	30" (76 cm)	Single Right Hinge	130/59
9900400	18" x 22" x 35.5" to 36.75" (46 x 56 x 90 to 93 cm)	30" (76 cm)	Single Right Hinge	90/41
9900500	12" x 22" x 35.5" to 36.75" (30 x 56 x 90 to 93 cm)	30" (76 cm)	Single Right Hinge	65/29
9900600	24" x 22" x 35.5" to 36.75" (61 x 56 x 90 to 93 cm)	30" (76 cm)	Single Left Hinge	130/59
9900700	18" x 22" x 35.5" to 36.75" (46 x 56 x 90 to 93 cm)	30" (76 cm)	Single Left Hinge	90/41
9900800	12" x 22" x 35.5" to 36.75" (30 x 56 x 90 to 93 cm)	30" (76 cm)	Single Left Hinge	65/29
 9904000	24" x 22" x 31.5" to 32.75" (61 x 56 x 80 to 83 cm)	30" (76 cm)	Single Right Hinge	120/54
 9904100	18" x 22" x 31.5" to 32.75" (46 x 56 x 80 to 83 cm)	30" (76 cm)	Single Right Hinge	85/39
 9904200	12" x 22" x 31.5" to 32.75" (30 x 56 x 80 to 83 cm)	30" (76 cm)	Single Right Hinge	60/27
 9904300	24" x 22" x 31.5" to 32.75" (61 x 56 x 80 to 83 cm)	30" (76 cm)	Single Left Hinge	120/54
 9904400	18" x 22" x 31.5" to 32.75" (46 x 56 x 80 to 83 cm)	30" (76 cm)	Single Left Hinge	85/39
 9904500	12" x 22" x 31.5" to 32.75" (30 x 56 x 80 to 83 cm)	30" (76 cm)	Single Left Hinge	60/27

Accessories

Interior Shelf Kits

Include epoxy-coated steel shelf and mounting hardware. Shelf may be mounted at one of three heights: 13.50", 15.25" and 17.00" (9.50", 11.25" and 13.00" for ADA height cabinets).

Width	Catalog #	Shipping Wt. lbs./kg
48"	9919100	15/6.8
36"	9919101	12/5.4
30"	9919102	10/4.5
24"	9919103	8/3.6
18"	9919104	7/3.2
12"	9919105	5/2.3

Filler Panels

One 8" filler panel is included with each Storage Cabinet to extend cabinet depth to 30" and to enclose the utility chase behind the cabinet. Cabinets supporting hoods with external depths greater than 33.2" require deeper filler panels.

Catalog #	Description	Shipping Wt. lbs./kg
9920306	Filler Panel, 8" deep	10/4.5
9920310	Filler Panel, 14" deep	13/5.9
9920312	Filler Panel, 20" deep	15/6.8
9920301	Filler Panel, 15.5" deep	13/5.9
9920307	ADA Filler Panel, 8" deep	9/4.1
9920311	ADA Filler Panel, 14" deep	12/5.4
9920313	ADA Filler Panel, 20" deep	14/6.4
9920304	ADA Filler Panel, 15.5" deep	12/5.4

 Cabinet height meets requirements of the ADA.



Protector® Vacuum Pump Storage Cabinets



Protector Vacuum Pump Storage Cabinet 9907100 with left hinge door.

Protector Vacuum Pump Storage Cabinets provide enclosed space for vacuum pump storage.

Features:

- Durable epoxy-coated steel construction.
- Attractive glacier white exterior complements laboratory casework and Labconco fume hoods.
- Manual-closing, non-locking door.
- Include four leveling feet and one 8" filler panel to increase cabinet depth from 22" to 30".
- Include one 115 volt, 60 Hz electrical duplex receptacle to provide power to the vacuum pump. **Wiring is required.**
- Include two rear cutouts for pass through of vacuum pump tubing.
- **Work surface is required** and sold separately. See pages 100-104.

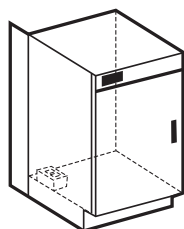

Ordering Information

Catalog #	Cabinet Dimensions (w x d x h)	Depth with standard filler panel	Door	Shipping Wt. lbs./kg
9907000	18" x 22" x 35.5" to 36.75" (46 x 56 x 90 to 93 cm)	30" (76 cm)	Right Hinge	90/41
9907100	18" x 22" x 35.5" to 36.75" (46 x 56 x 90 to 93 cm)	30" (76 cm)	Left Hinge	90/41

Accessories

Filler Panels

One 8" filler panel is included with each Storage Cabinet to extend cabinet depth to 30" and to enclose the utility chase behind the cabinet.

Catalog #	Description	Shipping Wt. lbs./kg
9920306	Filler Panel, 8" deep	10/4.5
9920310	Filler Panel, 14" deep	13/5.9
9920312	Filler Panel, 20" deep	15/6.8
9920301	Filler Panel, 15.5" deep	13/5.9

Dimensional Data

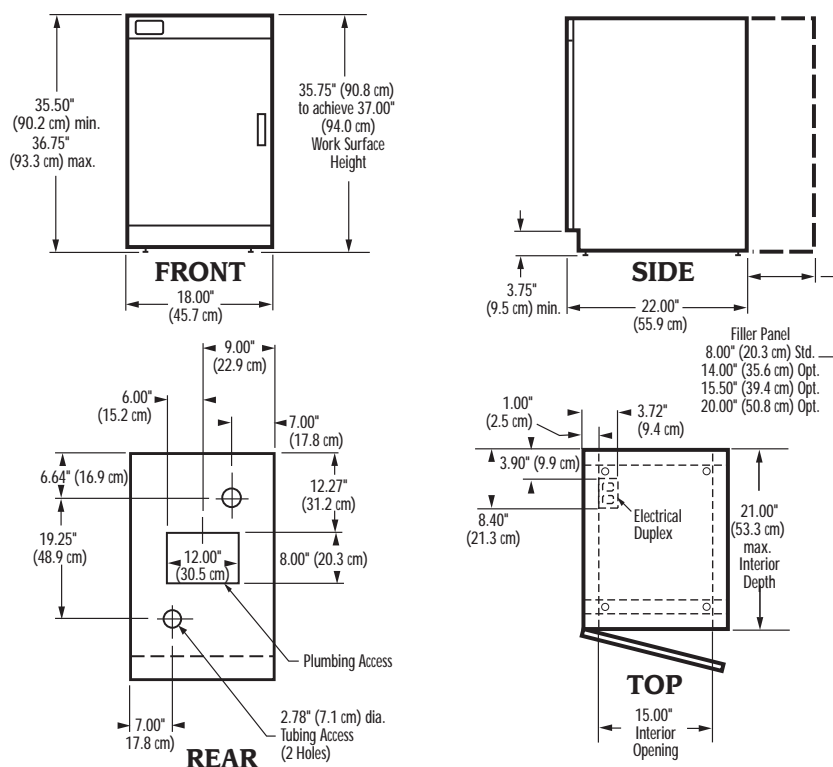



Telescoping Base Stands



Telescoping Base Stand 3746702, 4' wide. Inset: Accessory Shelf 3811101, 3' wide.

Base Stands have telescoping legs so that they may be adjusted to seven height positions.*

Features:

- Support Labconco fume hoods and enclosures.
- Durable 1.75" tubular, epoxy-coated steel.
- Attractive glacier white exterior complements laboratory casework and Labconco fume hoods.
- Adjust to seven height positions in 1" increments from 27.5 to 33.5".*
- Include four fixed leveling feet or 5" diameter toe-locking casters.
- Accessory Shelf, epoxy-coated 18 gauge steel, is designed to hook on the lower rear horizontal cross member. 9.9" (25.1 cm) deep. Sold separately. See below.
- Work surface is sold separately. See pages 100-104.

Ordering Information

Select the Base Stand that matches the width of the fume hood or enclosure it supports. When supporting enclosures with widths of 8 feet or larger, Base Stands of multiple widths may be mixed and matched so that their total width equals the width of the hood.

Telescoping Base Stands with Fixed Feet

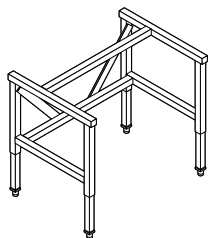

Nominal Width	Catalog #	Actual Width (A)	Shipping Wt. lbs./kg	For Use With:
2 feet	3746700	24.0" (61.0 cm)	65/29	Paramount, Protector XVS Station
3 feet	3746701	36.0" (91.4 cm)	72/33	Fiberglass 30 Hood**, Paramount, Protector XVS Station, Demonstration Hood
4 feet	3746702	48.0" (121.0 cm)	80/36	Protector Hood, Basic 47 Hood**, Paramount, Protector XVS Station, Protector Work Station
5 feet	3746703	60.0" (152.4 cm)	85/39	Protector Hood, Paramount
6 feet	3746704	72.0" (182.9 cm)	92/42	Protector Hood, Basic 70 Hood**, Paramount

Telescoping Base Stands with 5" diameter Toe-Locking Casters†

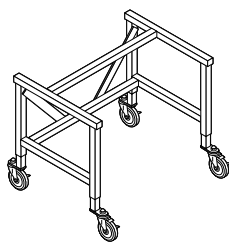

Nominal Width	Catalog #	Actual Width (A)	Shipping Wt. lbs./kg	For Use With:
2 feet	3746710	24.0" (61.0 cm)	65/29	Paramount, Protector XVS Station
3 feet	3746711	36.0" (91.4 cm)	76/34	Paramount, Protector XVS Station, Demonstration Hood
4 feet	3746712	48.0" (121.0 cm)	84/38	Paramount, Protector XVS Station, Protector Work Station
5 feet	3746713	60.0" (152.4 cm)	85/39	Paramount
6 feet	3746714	72.0" (182.9 cm)	96/44	Paramount, Protector XVS Station

Accessory Shelves

Nominal Width	Catalog #	Actual Width (A)	Shipping Wt. lbs./kg	Nominal Width	Catalog #	Actual Width (A)	Shipping Wt. lbs./kg
3 feet	3811101	36.0" (91.4 cm)	12/5	5 feet	3811103	60.0" (152.4 cm)	19/9
4 feet	3811102	48.0" (121.0 cm)	16/7	6 feet	3811104	72.0" (182.9 cm)	23/10

With casters

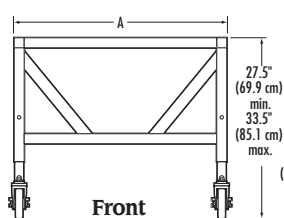

With fixed feet

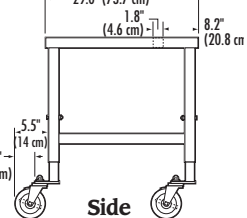

With fixed feet

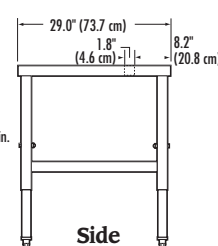
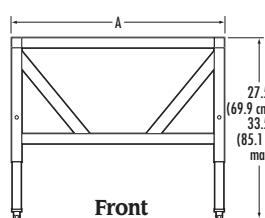

* Height selection and adjustment are required before the hood or enclosure is installed atop the stand.

** Basic and Fiberglass 30 Hoods are narrower than the base stands that support them.

† Enclosures supported by mobile Base Stands will require special modifications to incorporate flexible ducting, wiring and plumbing when applied.



Electric & Manual Hydraulic Lift Base Stands



Electric Hydraulic Lift Base Stand 3780300 is shown with Accessory Caster Kit 3784000.

Base stands have a built-in hydraulic lift so that height may be adjusted at any time. Stands are available with an electric lift and up/down switch or a manual lift and a hand crank. These adjustable stands allow you to position the stand and the enclosure it supports to accommodate persons of different heights and wheelchair-bound users, to transport equipment through doorways, and easier service access. When coupled with a flat work surface, the stands may be used alone as an adjustable height table.

 Stand height meets requirements of the ADA.

* Enclosures supported by mobile Base Stands will require special modifications to incorporate flexible ducting, wiring and plumbing when applied.



Manual Hydraulic Lift Base Stand 3780401.

- Optional accessory 5" diameter, toe-locking Caster Kit is available for field installation. See below.
- Work surface is not included. See pages 80 and 95.

Features

(Electric Hydraulic Lift Models):

- Include front-accessible up/down switch.
- Available in two electrical configurations. Models for 115 volt, 60 Hz operation include a 12-foot, 3-wire cord and plug. Models for 230 volt, 50 Hz operation include a 12-foot, 3-wire cord and NEMA 6-15P plug.
- Electrical components are UL listed.

Features

(Manual Hydraulic Lift Models):

- Include front-accessible hand crank. Turning the crank clockwise raises the stand; counterclockwise lowers it. The handle may be disengaged and folded under, out of the way, when not in use.

Accessory

3784000 Caster Kit*

Casters add mobility to the Hydraulic Lift Base Stand. Kit includes four 5" diameter, non-marking polyurethane casters with toe locks. Load rating for each caster is 250 pounds. Casters have bearings for quiet operation. Casters replace the fixed feet that are included with the stand.

Installation is required. Shipping weight 10 lbs. (4.5 kg)

Features (All Models):

- Support Paramount Ductless Enclosures, Protector XVS Ventilated Enclosures and Demonstration Hoods.
- Support loads up to 1000 pounds.
- ADA-compliant.
- Durable 1.75" tubular, epoxy-coated steel frame with rear crossbar supports. Support frame is 2.0" x 3.0".
- Attractive glacier white exterior complements laboratory casework and Labconco products.
- Height is infinitely adjustable from 25.5" to 33.5" high.
- Include four powder-coated, die-cast feet with levelers.



Electric & Manual Hydraulic Lift Base Stands

Ordering Information

Select the Base Stand that matches the width of the enclosure it supports.

Electric Hydraulic Lift Base Stands

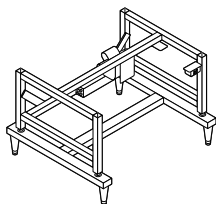

Nominal Width	Catalog #	Overall Width x Depth	Switch Location	Electrical Requirements	Shipping Wt. lbs./kg	For Use With:
3 feet	3780300	37.2" w x 34.3" d	Right Side	115 volts, 60 Hz, 2.4 amps	100/45	Paramount, Protector XVS, Demonstration Hood
3 feet	3780303*	37.2" w x 34.3" d	Right Side	230 volts, 50 Hz, 0.8 amps	100/45	Paramount, Protector XVS, Demonstration Hood
4 feet	3780301	49.2" w x 34.3" d	Right Side	115 volts, 60 Hz, 2.4 amps	120/54	Paramount, Protector XVS, Protector Work Station**
4 feet	3780304*	49.2" w x 34.3" d	Right Side	230 volts, 50 Hz, 0.8 amps	120/54	Paramount, Protector XVS, Protector Work Station**
6 feet	3780302	73.2" w x 34.3" d	Right Side	115 volts, 60 Hz, 2.4 amps	150/68	Paramount, Protector XVS
6 feet	3780305*	73.2" w x 34.3" d	Right Side	230 volts, 50 Hz, 0.8 amps	150/68	Paramount, Protector XVS

Manual Hydraulic Lift Base Stands

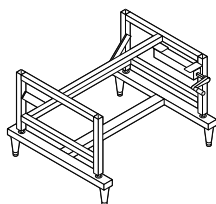

Nominal Width	Catalog #	Overall Width x Depth	Handle Location	Shipping Wt. lbs./kg	For Use With:
3 feet	3780400	37.2" w x 34.3" d	Right Side	100/45	Paramount, Protector XVS, Demonstration Hood
4 feet	3780401	49.2" w x 34.3" d	Right Side	120/54	Paramount, Protector XVS, Protector Work Station**
6 feet	3780402	73.2" w x 34.3" d	Right Side	150/68	Paramount, Protector XVS

* International electrical configuration

**Not compatible with 6942003 Work Surface with Sink

Electric Lift

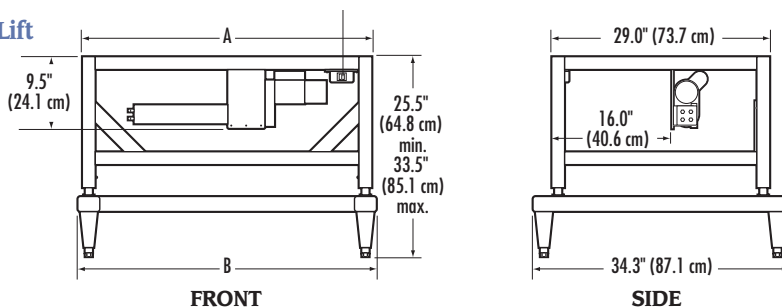

3-Foot Models	A	B
3780300, 3780303, 3780400	36.0" (91.4 cm)	37.2" (94.5 cm)
4-Foot Models	A	B
3780301, 3780304, 3780401	48.0" (121.9 cm)	49.2" (125.0 cm)
6-Foot Models	A	B
3780302, 3780305, 3780402	72.0" (182.9 cm)	73.2" (185.9 cm)

Manual Lift

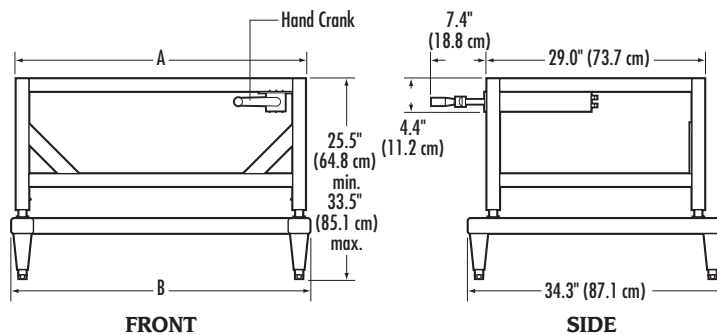



ADA Base Stand



ADA Base Stand 9938600. Finish panels are not shown.

The ADA Base Stand is designed to support 4' hoods to the ADA Standard for height and knee clearance.

Features:

- Supports 4' Labconco fume hoods and enclosures including Protector Premier, XStream, XL Benchtop, XLE, Stainless Steel and PVC; and Basic Hoods, Paramount Ductless Enclosures, Protector XVS Ventilation Stations and Protector Work Stations.
- Durable 2" tubular, epoxy-coated steel.
- Attractive glacier white exterior complements laboratory casework and Labconco fume hoods.
- Includes four fixed leveling feet and epoxy-coated finish panels: two side, one back and one to hide a sink and plumbing mounted on either side.
- **Work surface is sold separately.** See pages 80, 95 and 100-104.

Ordering Information

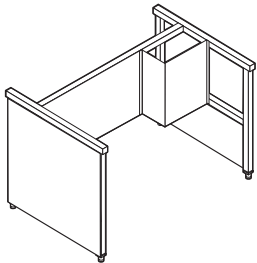

Nominal Width	Catalog #	Width	Depth	Height	Shipping Wt. lbs./kg	For Use With:
4 feet	9938600	48.0"	29.0"	32.5" - 33.5"	84/38	Protector Hood, Basic 47 Hood*, Paramount, Protector XVS, Protector Work Station

Dimensional Data

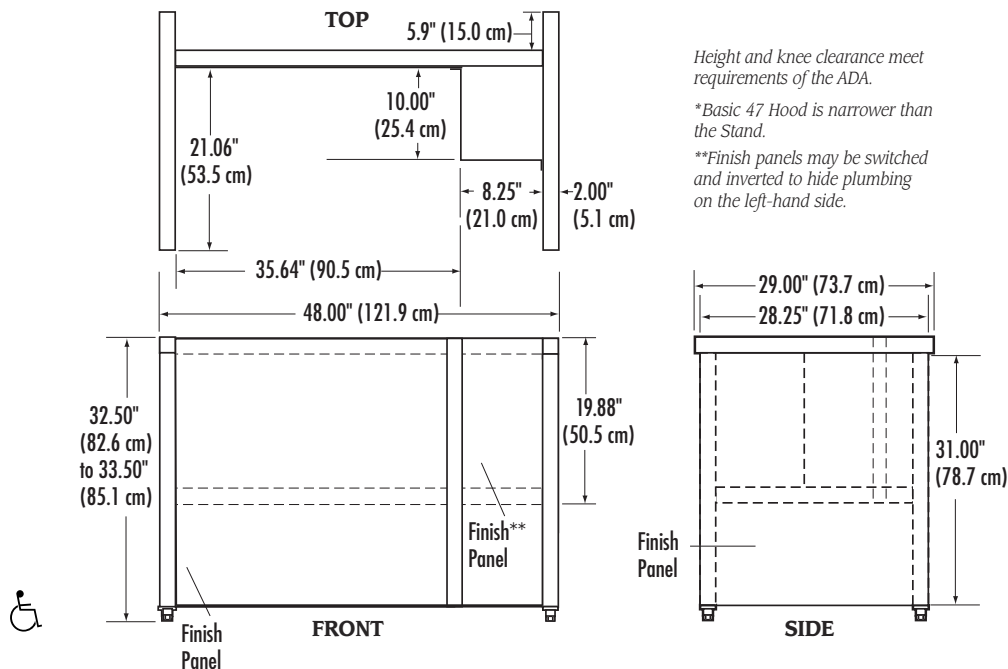



Accessories

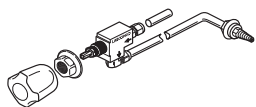

Standard Service Fixture Kits

For mounting on the left or right side of any Protector Premier, XStream, XL, XLE or PVC Hood. Each kit includes one remotely-controlled service fixture with valve and 0.25" diameter tubing, color-coded fixture knob and color-coded hose connector. * **Inlet tubing is not included.** Shipping weight 4 lbs. (1.8 kg)

Catalog #	Kit	Tubing	Valve	Knob/Connector Color	Max. Flow Rate	Max. Working Pressure†
9808300**	Cold Water (CW)	Copper	Brass	Green	3.5 GPM (13.2 LPM)	40 psi
9808400**	Air (AIR)	Copper	Brass	Orange	23.7 CFM	40 psi
9808500**	Vacuum (VAC)	Copper	Brass	Yellow	8.6 CFM	14.7 psi
9808700**	Gas (GAS)	Brass	Brass	Blue	29.0 CFM (441 BTU/sec)	40 psi
9808800**	Argon (ARG)	Copper	Brass	Gray	20.2 CFM	40 psi
9808900**	Hot Water (HW)	Copper	Brass	Red	3.5 GPM (13.2 LPM)	40 psi
9809100**	Deionized/ Distilled Water (DI)	Stainless Steel	Nickel-Plated & Stainless Steel	White	3.5 GPM (13.2 LPM)	40 psi
9809200**	Steam (STM)	Copper	Brass	Black	0.5 LBM/min	40 psi
9809300**	Nitrogen (NIT)	Copper	Brass	Brown	24.1 CFM	40 psi
9809700**††	Oxygen (OXY)	Copper	Brass with Oxygen- Compatible Lubricant	Light Green	22.6 CFM	40 psi

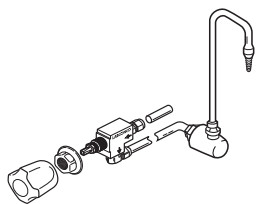

Cold Water Gooseneck Fixture Kits

For mounting on the left or right side of any Protector Premier, XStream, PVC, Stainless Steel, XL or XLE Laboratory Hood with 24" to 30" interior depth. Each kit includes one remotely-controlled gooseneck with brass valve and 0.375" diameter copper tubing and green fixture knob. **Inlet tubing is not included.** Contact Labconco for ordering information on Gooseneck Fixture Kits for Protector Hoods with interior depths of 36" or 48". Shipping weight 10 lbs. (4.5 kg)

Catalog #	Kit	Description	Max. Flow Rate	Max. Working Pressure††
9827900**	Cold Water (CW) Gooseneck	For Hoods with Interior Depths of 24" to 30". Includes green epoxy-coated brass rigid/swivel gooseneck.	3.5 GPM (13.2 LPM)	40 psi
9857700†††	Cold Water (CW) Gooseneck	For Hoods with Interior Depths of 24" to 30". Includes gray PVC rigid gooseneck.	3.5 GPM (13.2 LPM)	40 psi

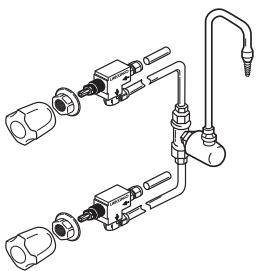

Hot and Cold Water Mixing Gooseneck Fixture Kit

For any Protector Premier, XStream, PVC, Stainless Steel, XL or XLE Laboratory Hood with interior depth of 24" to 30". Each kit includes one remotely-controlled, white epoxy-coated, brass rigid/swivel gooseneck with brass valve and 0.25" diameter copper tubing, one green fixture knob and one red fixture knob. **Inlet tubing is not included.** Contact Labconco for ordering information on Gooseneck Fixture Kits for Protector Hoods with interior depths of 36" or 48". Shipping weight 11 lbs. (5.0 kg)

Catalog #	Kit	Description	Max. Flow Rate	Max. Working Pressure††
9828000†††	Hot (HW) and Cold Water (CW) Mixing Gooseneck	For Hoods with Interior Depths of 24" to 30"	3.5 GPM (13.2 LPM)	40 psi

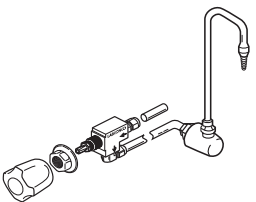

Deionized/Distilled Water Gooseneck Fixture Kit

For mounting on the left or right side of any Protector Premier, XStream, PVC, Stainless Steel, XL or XLE Laboratory Hood with 24" to 30" interior depth. Each kit includes one remotely-controlled, gray PVC rigid gooseneck with stainless steel valve and 0.25" diameter tubing and white fixture knob. Contact Labconco for ordering information on Gooseneck Fixture Kits for Protector Hoods with interior depths of 36" or 48". **Inlet tubing is not included.** Shipping weight 10 lbs. (4.5 kg)

Catalog #	Kit	Description	Max. Flow Rate	Max. Working Pressure††
9853400†††	Deionized/Distilled Water (DW) Gooseneck	For Hoods with Interior Depths of 24" to 30"	3.5 GPM (13.2 LPM)	40 psi

GPM – gallons per minute LPM – liters per minute CFM – cubic feet per minute BTU/sec – British thermal unit per second LBM/min – pounds mass per minute
 * Contact Labconco for ordering information on Standard Service Fixtures with chrome-plated brass hose connectors for Protector Stainless Steel Hoods.
 † Maximum allowable pressure is 200 psi with a working pressure of 40 psi. **Protector Stainless Steel and PVC Hoods require e drilled hole in liner. †† WaterSaver
 ††† Requires 1.375" dia. drill hole in liner.



Accessories

9808310 Washdown Valve Kit

For mounting on the left or right side of any Protector Stainless Steel or PVC Perchloric Acid Hood or Acid Digestion Hood. Provides water for up to three wash rings in ductwork. (Wash rings are sold separately. See Blower Booklet.) Kit includes one remotely controlled fixture with brass valve, 0.375" diameter copper tubing and color-coded fixture knob. **Inlet tubing is not included.** Maximum flow rate is 3 GPM. Maximum working pressure is 40 psi. Shipping weight 4 lbs. (1.8 kg)

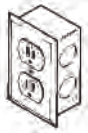

Duplex Electrical Receptacle Kits

For mounting in left or right side of any 4', 5', 6', 7' or 8' Protector Premier, XStream, XL or XLE Laboratory Hood. Each kit includes duplex electrical receptacle, wiring, junction box and receptacle cover plate. Contact Labconco for ordering information on Duplex Electrical Receptacle Kits for Protector Hoods with widths of 10', 12' or 16'.

Catalog #	Kit	For Hood with exterior widths:	Shipping Wt. lbs./kg
9851100	115 volts, 20 amps AC	4', 5', 6' and 8'	4/1.8
9851500	115 volts, 20 amps AC, GFCI	4', 5', 6' and 8'	4/1.8
9854200	230 volts, 20 amps AC	4', 5', 6' and 8'	4/1.8

Guardian™ 1000 Digital Airflow Monitor Kits

Monitor and alert the operator to low airflow conditions. Include face plate with circuit board, electrical power pack, airflow hose and flow hose adapter. LCD displays actual airflow in fpm or m/sec from 0 to 999 fpm (0 to 5.0 m/s). Audible/visual alarm alerts user to sustained low velocity condition. Calibration instructions displayed on LCD. LED lights display red for alarm, yellow for caution, green for normal. Include temperature-compensated sensor, external alarm, night setback and alarm mute functions. UL and CE listed. For installation in a factory-prepared cutout on upper portion of right fixture panel. Contact Labconco for ordering information on an optional factory-prepared RS-485 port for Modbus RTU communication.



Catalog #	Description	For use with Protector Hood:	Shipping Wt. lbs./kg
9743211	115 volts, 60 Hz	Premier, XStream, XL, XLE, Stainless Steel and PVC	6/2.7
9743212*	230 volts, 50 Hz	Premier, XStream, XL, XLE, Stainless Steel and PVC	6/2.7

Guardian™ 500 Airflow Monitor Kits

Monitor and alert the operator to low airflow conditions. Include face plate with circuit board, electrical power pack, vinyl tubing and airflow tube adapter. From the monitor's face plate, the user can easily select and calibrate a setpoint between 30 and 250 fpm using a velocity meter and a screwdriver. A green LED glows to indicate "safe" when airflow is greater than the low setpoint. A red LED flashes to indicate "low" when airflow is below the low setpoint. An amber LED flashes when the sash is raised above the maximum safe working opening. An audible alarm sounds (and can be muted) when under "low" and "sash high" conditions. Include night setback, external alarm and alarm mute functions. For installation in a factory-prepared cutout on upper portion of right fixture panel.



Catalog #	Description	For use with Protector Hood:	Shipping Wt. lbs./kg
9743213	115 volts, 60 Hz	Premier, XStream, XL, XLE, Stainless Steel and PVC	6/2.7
9743214*	230 volts, 50 Hz	Premier, XStream, XL, XLE, Stainless Steel and PVC	6/2.7

9743203 Guardian™ Digital Airflow Monitor Kit

For use on Protector ClassMate Laboratory Hoods only. Monitors and alerts the operator to low airflow conditions. Includes face plate with circuit board, electrical power pack, vinyl tubing, side wall flow tube adaptor and wiring instructions. From the monitor's face plate, the user can easily select and calibrate a setpoint between 50 and 250 fpm using a velocity meter. An LCD displays actual face velocity. If the hood's face velocity falls below the programmable setpoint, an audible alarm sounds and the LOW indicator glows red. The TEST RESET switch, when pressed, mutes the audible alarm. The EMERG. PURGE switch, when configured and pressed, can be used to activate a relay to open a hood damper (not included). **Requires cutout in upper right portion of front panel.** Contact Labconco for ordering information on Guardian Digital Airflow Monitors for other Protector Hoods. Shipping weight 6 lbs. (2.7 kg)



9743204 Guardian™ Jr. Airflow Monitor Kit

For use on Protector ClassMate Laboratory Hoods only. Monitors and alerts the operator to low airflow conditions. Includes face plate with circuit board, electrical power pack, vinyl tubing and airflow tube adapter. From the monitor's face plate, the user can easily select and calibrate a setpoint between 30 and 250 fpm using a velocity meter and a screwdriver. If the hood's face velocity falls below the setpoint for more than 6 seconds, an audible alarm sounds and the ALERT indicator glows red. The TEST RESET switch, when pressed, mutes the alarm. For installation in a factory-prepared cutout on upper portion of right fixture panel. **Requires cutout in upper right portion of front panel.** Shipping weight 6 lbs. (2.7 kg)



* International electrical configuration



Accessories



4852600 Side-Mount Oval Polypropylene Cupsink

Mounts on side wall of Protector XL Floor-Mounted Hoods. 6" x 3" cupsink. 1.5" NPSM* thread.
Requires a 1.875" diameter drilled hole in liner. Shipping weight 4 lbs. (1.8 kg)

3-Sided Ceiling Enclosure Kits

The panels extend above the top of the hood to the ceiling to hide exposed ductwork, plumbing and wiring. For any Protector Premier, XStream, XL, XLE, Stainless Steel or PVC Laboratory Hood. Each kit includes three glacier white epoxy-coated steel ceiling enclosure panels, one for the front of the hood and one for each side of the hood.

Hood Width	Hood Interior Depth	Enclosure Height Range in Inches		
		10.06/13.08	13.08/17.62	17.62/24.50
4'	24"	9852003	9852004	9852005
	30"	9852103	9852104	9852105
	36"	9852203	9852204	9852205
5'	24"	9852009	9852010	9852011
	30"	9852109	9852110	9852111
	36"	9852209	9852210	9852211
6'	24"	9852015	9852016	9852017
	30"	9852115	9852116	9852117
	36"	9852215	9852216	9852217
8'	24"	9852021	9852022	9852023
	30"	9852121	9852122	9852123
	36"	9852221	9852222	9852223

Front Ceiling Enclosure Kits

The enclosure panel extends above the top of the front of the hood to the ceiling to hide exposed ductwork and wiring. For any Protector Premier, XStream, XL, XLE, Pass-Through, Stainless Steel or PVC Laboratory Hood. Each kit includes one glacier white epoxy-coated steel ceiling enclosure panel for the front of the hood.

Hood Width	Enclosure Height Range in Inches		
	10.06/13.08	13.08/17.62	17.62/24.50
4'	9852303	9852304	9852305
5'	9852309	9852310	9852311
6'	9852315	9852316	9852317
8'	9852321	9852322	9852323

Side Ceiling Enclosure Kits

The enclosure panel extends above the top of the side of the hood to the ceiling to hide exposed ductwork and wiring. For any Protector Premier, XStream, XL, Stainless Steel or PVC Laboratory Hood. Each kit includes one glacier white epoxy-coated steel ceiling enclosure panel for one side of the hood.

Hood Side	Hood Interior Depth	Enclosure Height Range in Inches		
		10.06/13.08	13.08/17.62	17.62/24.50
Right	24"	9852403	9852404	9852405
Right	30"	9852409	9852410	9852411
Right	36"	9852415	9852416	9852417
Left	24"	9833703	9833704	9833705
Left	30"	9833709	9833710	9833711
Left	36"	9833715	9833716	9833717

* National Pipe Straight Mechanical



Accessories

Rear Finish Panel Kits

The panel hides the hood's interior components. Recommended when hood is mounted on a casework island, each kit includes a glacier white epoxy-coated steel panel to provide a finished appearance for the rear of the hood. Contact Labconco for ordering information on Rear Finish Panels for Protector XL Floor-Mounted Hoods.

Catalog#	Nominal Width	Dimensions (w x h)	For use with Protector Hood:	Shipping Weight lbs./kg
6987300	4 Feet	43" x 9.5"	ClassMate	20/9
6987301	5 Feet	55" x 9.5"	ClassMate	25/12
6987302	6 Feet	67" x 9.5"	ClassMate	30/14
9851800	4 Feet	48" wide x 59" high	Premier, XStream, XL, XLE, Stainless Steel, PVC	70/32
9851801	5 Feet	60" wide x 59" high	Premier, XStream, XL, XLE, Stainless Steel	80/36
9851802	6 Feet	72" wide x 59" high	Premier, XStream, XL, XLE, Stainless Steel, PVC	90/41
9851803	8 Feet	96" wide x 59" high	Premier, XStream, XL, XLE, Stainless Steel, PVC	120/54
9851804	10 Feet	120" wide x 59" high	XL	160/73
9851805	12 Feet	144" wide x 59" high	XL	180/82
9851806	16 Feet	192" wide x 59" high	XL	240/109

Distillation Grid Kits

Kits include stainless steel rods, connectors, instruction sheet and drill template.

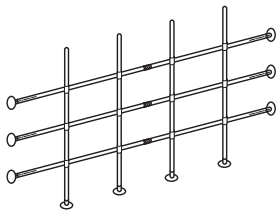

Catalog #	Description	For use with Protector Hood:	Shipping Wt. lbs./kg
6973300	4 Feet	ClassMate	15/7
6973301	5 Feet	ClassMate	20/9
6973302	6 Feet	ClassMate	25/11
9725204	4 Feet	Premier, XStream, XL Benchtop, XLE	10/4.5
9725205	5 Feet	Premier, XStream, XL Benchtop, XLE	15/6.8
9725206	6 Feet	Premier, XStream, XL Benchtop, XLE	20/9.1
9725200	8 Feet	Premier, XStream, XL Benchtop, XLE	25/11.3
9725201	10 Feet	XL Benchtop	30/13.6
9725202	12 Feet	XL Benchtop	35/15.9
9725203	16 Feet	XL Benchtop	45/20.4

Contact Labconco for ordering information on distillation grids for Protector XL Floor-Mounted Hoods.

Auxiliary-Air Plenum Kits

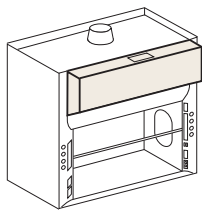

For use with 4', 5', 6' and 8' Protector Premier Laboratory Hoods for use with remote blower and XL Benchtop Laboratory Hoods with vertical-rising sashes only. Provide a means to introduce supplemental air for the hood exhaust and limit the percentage of tempered air removed from the laboratory. Useful for air-starved laboratories where room make-up air volume is not adequate to supply a laboratory hood. Each kit includes a glacier white epoxy-coated steel plenum with auxiliary-air inlet, 12.06" wide x 6.62" deep. 8' plenum has two inlets. The plenum replaces the hood's front panel and extends 7.59" in front of the hood when installed. A auxiliary-air inlet centerline is located 1.75" in front of hood's corner posts when the plenum is installed. **Installation, separate ductwork and remote blower are required (not included). Auxiliary-Air Transition Adapter 4889300 is recommended to permit connection of the rectangular inlet to 10" diameter duct.** See Blowers Booklet in back pocket for ordering information on recommended Coated Steel Blowers and Auxiliary-Air Transition Adapter.

Catalog#	Nominal Width	Actual Dimensions (w x d x h)	Static Pressure Loss (50% auxiliary air/exhaust ratio)	Recommended Coated Steel Blower/Adapter*	Shipping Weight lbs./kg
9834004	4 Feet	43.75" x 14.81" x 23.25"	0.17" @ 100 fpm (365 CFM)	7068000/4722401	100/45
9834005	5 Feet	55.75" x 14.81" x 23.25"	0.17" @ 100 fpm (480 CFM)	7068000/4722401	125/57
9834006	6 Feet	67.75" x 14.81" x 23.25"	0.17" @ 100 fpm (590 CFM)	7068200/4722401	150/68
9834008	8 Feet	91.75" x 14.81" x 23.25"	0.17" @ 100 fpm (830 CFM)	7068600/4722401**	200/90

* Blowers supply auxiliary air volume equal to 50% of exhaust volume of fume hood and provide up to 100 equivalent resistance in feet of 10" diameter straight duct.
 ** Manual Damper 5983400 or equal is required.



Accessories

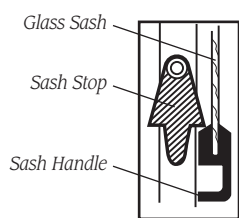

Sash Stop Kits

A Sash Stop restricts how far a vertical-rising sash may be opened. This small plastic device may be easily field installed on the fixture panel of any Protector Premier, XStream, XL Benchtop or Stainless Steel Hood. These hoods have been factory-prepared to accommodate a sash stop at the 60% open position (18" to work surface). Alternate sash positions may be field drilled. Each Sash Stop Kit includes components for one sash. Shipping weight 0.5 lb. (0.2 kg)

Catalog #	For use with Protector Hood:
9724500	Premier, XL Benchtop, Stainless Steel
9724501	XStream
9724502	8' Premier with dual sash; 8', 10' and 12' XL Benchtop with dual sash

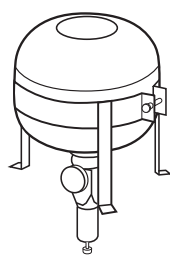

1115003

Snuffer™ Fire Extinguishers

Use ABC dry powder to provide fire protection to Protector and Basic Hoods. A fusible link melts at 165° F (74° C) and chemical powder automatically discharges within 5 seconds to extinguish the fire. A pressure gauge permits visual inspection. Rechargeable. **A drilled hole is required in hood liner.** Labconco recommends factory installation. Contact Labconco for selection assistance based on your application, hood liner material, hood width and depth.

Catalog #	Description	Charge Weight lbs./kg	Shipping Weight lbs./kg
1115003	Stainless steel cylinder mounts vertically above hood liner. UL listed.	5/2.3	9/4.0
1115004	Stainless steel cylinder mounts vertically above hood liner. UL listed.	8/3.6	14/6.

Snuffer Selection Chart

Width of Hood	4'				5'				6'				8'				10'				12'				16'			
Interior Depth of Hood	24"	30"	36"	48"	24"	30"	36"	48"	24"	30"	36"	48"	24"	30"	36"	48"	24"	30"	36"	48"	24"	30"	36"	48"	24"	30"	36"	48"
Catalog Number	Number of Extinguishers Required																											
1115003	1	1	2	2	1	2	2		2	2	2																	
1115004							1			1	1	1	2	1	2	2	2	2	2	2	2	2	3	2	2	2	3	3



3925000 Utility Shelves

For use with Protector XStream Laboratory Hoods, Paramount Ductless Enclosures, Protector XVS Ventilation Stations and Protector Work Stations. Three epoxy-coated steel shelves attach to the rear baffle perforations to hold items such as a balance printer, utensils and other miscellaneous supplies. The utensil shelf has a scalloped front edge to support scalpels, forceps and other items. Shipping weight 5 lbs. (2 kg)



3927700 Bottle Holder

For use with Protector XStream Laboratory Hoods, Paramount Ductless Enclosures, Protector XVS Ventilation Stations and Protector Work Stations. Epoxy-coated steel. Attaches to the rear baffle perforations to hold a squirt bottle or other round container. 3" diameter opening. Shipping weight 1 lb. (0.5 kg)



3927800 Tissue Holder

For use with Protector XStream Laboratory Hoods, Paramount Ductless Enclosures, Protector XVS Ventilation Stations and Protector Work Stations. Epoxy-coated steel. Attaches to the rear baffle perforations to hold tissue wipers in the upside down position. An opening in the bottom of the holder permits wipers to be dispensed from the bottom. Shipping weight 1 lb. (0.5 kg)



Appendix: Advancing Laboratory Ventilation Technology

Airflow Test Laboratory

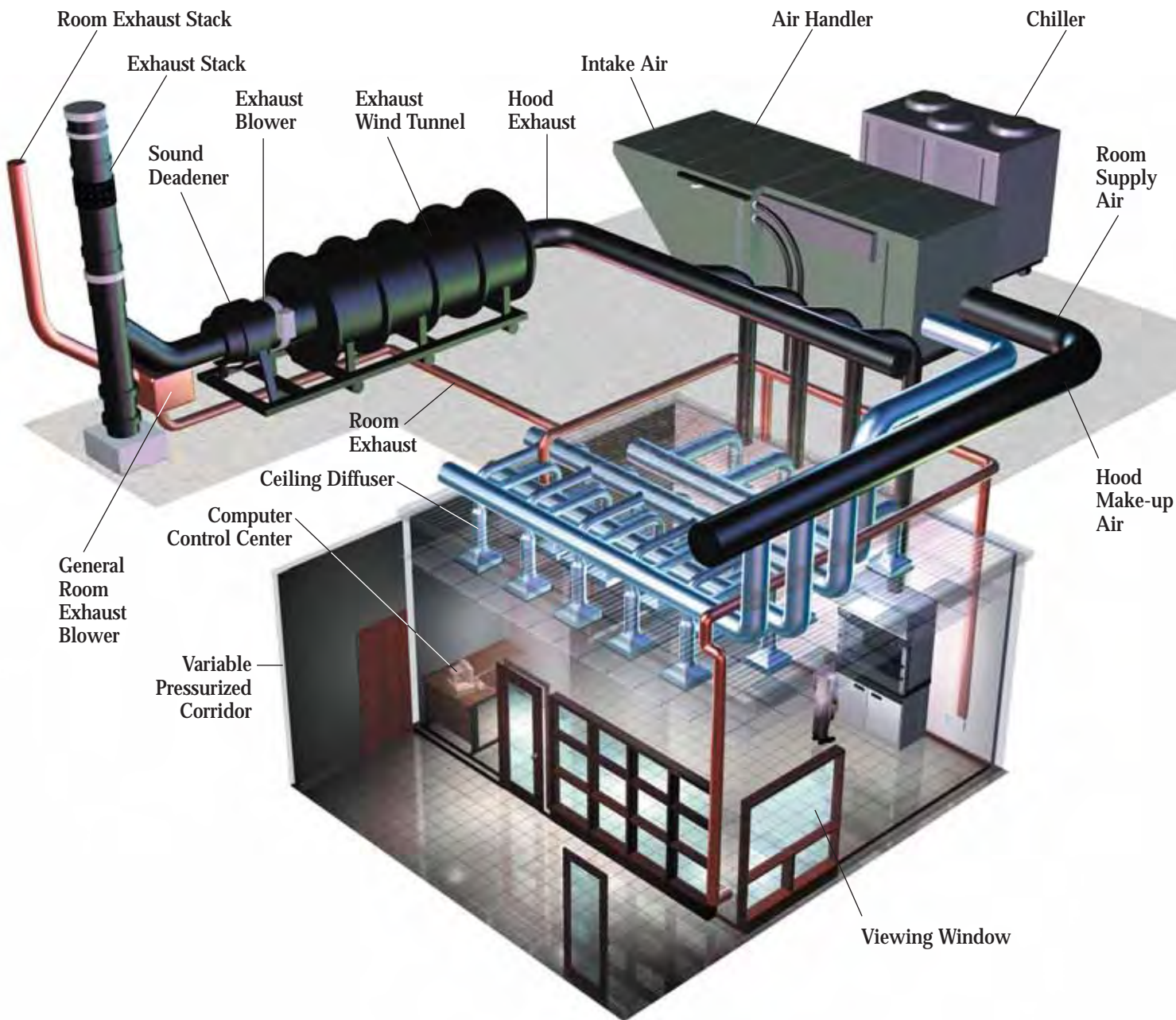

Smoke tests demonstrate fume hood containment.



Airflow conditions are monitored and controlled from a computer located in the laboratory.



Dimensional drawings of our ventilation equipment are computer generated to help you with your installation.



Appendix: Advancing Laboratory Ventilation Technology



© Steven Long

At the Rochester Institute of Technology, each Protector XStream Laboratory Hoods is outfitted with eight service fixtures, including a gooseneck faucet.



Protector XStream Laboratory Hoods line the walls in this laboratory at Gwinett University Center, Lawrenceville, Georgia.



© Mike Sinclair

These 32" high Protector XVS Ventilation Stations are used as student work stations at Forham University, Bronx, New York.

Labconco — Your Ventilation Partner For Your Next Laboratory Project

Whether you're selecting a single hood, renovating an existing laboratory or starting from the ground up, you can rely on Labconco for assistance. Labconco engineers, product specialists and technical service representatives comprise a focused group dedicated to helping customers find solutions to their laboratory ventilation problems.

Our experts share their extensive knowledge and resources so they can quickly act upon your requests for ventilation products including unique, custom-designed fume hoods. From the beginning to the end of your project, we can serve you in many other ways as well. Below are some of the project elements we can assist you with:

- product selection
- laboratory space planning
- ventilation equipment layout/placement recommendations
- identification of cost and energy saving alternatives
- consultation with your project manager or architect
- submittal packages with CAD drawings
- detailing and specification of Labconco products
- referral to reliable, time-proven vendors for products and services to complete your project including casework, installation and performance certification
- training for your workers on the proper, safe use of your Labconco products
- follow up contact throughout the life of the project and after installation is complete to ensure satisfaction

State-of-the-Art Airflow Test Laboratory

Labconco's Airflow Test Laboratory (diagram on page 122) enhances our capabilities to serve our customers with innovative ventilation products, ASHRAE testing, and replication of specific situations or field conditions. Measuring over 500 square feet, the facility can accommodate a single custom fume hood up to 16 feet wide or four 4-foot fume hoods simultaneously. It has the capacity to exhaust air volumes up to 5600 cubic feet per minute.

Sophisticated software and direct digital controls allow us to monitor and regulate airflow conditions from a computer screen. The entire room is sealed, creating its own "microenvironment" so that a customer's laboratory conditions can be recreated to troubleshoot existing ventilation problems or to anticipate possible future ventilation scenarios. One hundred percent non-recirculated air to the room is provided from the outside after passing through both HEPA and carbon filters to ensure removal of contaminants that could interfere with sophisticated containment testing. The room supply air is heated and/or cooled to pre-set temperature requirements. Humidity may also be controlled and monitored.



Appendix: Advancing Laboratory Ventilation Technology

The Airflow Test Laboratory features fourteen laminar flow ceiling diffusers that introduce supply air to the laboratory and can be individually controlled to provide the ultimate in supply air flexibility. We can shift supply air volumes through one or all fourteen diffusers. Direct digital controls give us the ability to vary the number of room air changes and to create either a positive or negative pressure relationship to the outside corridor.

Located at Labconco's headquarters in Kansas City, the Airflow Test Laboratory is designed for research as well as to showcase our ventilation capabilities to visiting customers. Its range of performance is best demonstrated in person, so we encourage you to be our guest in the near future. Your visit will include hands-on work in the Airflow Test Laboratory and tours of Labconco design and production departments. You'll also have an opportunity to inspect a wide array of Labconco laboratory equipment in our Demonstration Laboratory and Auditorium.

Additional Products from Labconco

In addition to the fume hoods and carbon-filtered enclosures featured in this catalog, Labconco manufactures a variety of other products used in laboratory construction projects. Contact Labconco at 800-821-5525, 816-333-8811 or www.labconco.com for more information on the following products:

- biological safety cabinets
- HEPA-filtered enclosures
- clean benches
- balance enclosures
- glove boxes
- laboratory animal cage changing stations
- glassware washers
- water purification systems



© Mike Sinclair

At Meredith College, Raleigh, North Carolina, Protector XL Laboratory Hoods mounted on Protector Acid and Solvent Laboratory Hoods alternate with Protector XL Laboratory Hoods mounted on wood casework. One hood is mounted lower and with accessibility underneath for a wheelchair.



© Mike Sinclair

A Protector XL Floor-Mounted Laboratory Hood sits next to a Protector Premier Laboratory Hood at Clemson University, Clemson, South Carolina.



© Dan Rockafellow

At Missouri State Highway Patrol Crime Laboratory, an undercounter FlaskScrubber keeps labware clean.



© Steven Long

Three Purifier Logic Biosafety Cabinets line one wall of this research laboratory at the University of Rochester James P. Wilmot Center in Rochester, New York.



Appendix: Advancing Laboratory Ventilation Technology



© Mike Sinclair

© Steven Long

*A ceiling enclosure hides the ductwork of this Protector XL Laboratory Hood located at University of California-San Francisco.
Inset: A Protector Stainless Steel Perchloric Acid Laboratory Hood at Union University, Jackson, Tennessee, features custom combination horizontal-sliding/vertical rising sashes and charcoal dry powder epoxy coated exterior.*



Index by Catalog Number

Catalog Number	Page Number	Catalog Number	Page Number	Catalog Number	Page Number	Catalog Number	Page Number	Catalog Number	Page Number
1115003	121	3811103	113	3975603	80	6961301	73	7282400	63
1115004	121	3811104	113	3975800	95	6961302	73	8026000	98
1361100	104	3908400	84, 95	3975801	95	6963200	77, 78	9682100	59
1361200	104	3908401	82, 95	4005000	104	6963220	77, 78	9682200	55
1432600	104	3908402	90, 95	4005100	104	6963300	77, 78	9682300	63
1968800	94	3908406	95	4005200	104	6963301	77, 78	9682400	63
2246300	68	3908407	95	4005400	104	6963302	74, 77	9683000	14, 15
2246301	68	3908408	95	4005800	104	6963320	77, 78	9700100	30, 38
2246400	64, 68	3908409	95	4005900	104	6963321	77, 78	9700101	30, 38
2246401	68	3908410	95	4708600	97, 98	6963322	77	9700102	30, 38
2246500	68	3908411	84, 95	4708700	97, 98	6963400	77	9700103	26, 30, 38
2246501	68	3908800	98	4708900	97	6963401	74, 77, 78	9700104	30, 38
2246600	67	3908801	98	4722200	97, 98	6963402	77, 78	9700105	30, 38
2246601	67	3909200	96	4724200	97, 98	6963403	77, 78	9700200	30, 38
2246602	67	3909201	96	4799000	99	6963420	77, 78	9700201	30, 38
2246603	67	3909900	80	4844400	69	6963421	77, 78	9700202	30, 38
2246604	67	3909901	74, 80	4844401	69	6963422	77, 78	9700203	30, 38
2246605	67	3909902	74, 80	4852500	69	6963423	77, 78	9700204	30, 38
2246606	67	3909906	80	4852600	119	6963501	77, 78	9700205	30, 38
2246700	68	3909907	80	4861700	97, 98	6963503	77, 78	9700300	31, 38
2246701	68	3909908	80	4861800	97, 98	6963521	77, 78	9700301	31, 38
2246702	68	3909910	80	4862010	85	6963523	77, 78	9700302	31, 38
2246703	68	3909911	80	4862030	84, 85	6963601	76, 77, 78	9700303	31, 38
2246704	68	3912400	85, 97	4863010	82, 85	6963603	78	9700304	31, 38
2246705	68	3912401	85, 97, 98	4863030	82, 85	6963621	77, 78	9700305	31, 38
2246706	68	3912402	85, 97	4863500	97, 98	6963623	77, 78	9700400	31, 38
2247300	64, 66, 67	3912403	85, 97, 98	4863501	97, 98	6963700	81	9700401	31, 38
2247301	67	3913600	96	4864010	85	6963800	80	9700402	31, 38
2247400	67	3923400	94	4864030	85	6963801	79, 80	9700403	31, 38
2247401	67	3923401	94	4865010	85	6963802	80	9700404	31, 38
2247500	67	3923402	94	4865030	85	6963803	80	9700405	31, 38
2247501	67	3924000	97, 98	4865060	85	6963900	81	9700801	36, 40
2832600	69, 71	3924200	95	4866010	85	6963901	81	9700803	36, 40
2832601	69, 71	3924201	95	4866030	85	6963902	81	9700805	32, 34, 36, 40
2832602	69, 71	3924202	95	4868010	85	6963903	81	9700807	35, 39
2832603	69, 71	3925000	96, 121	4868030	85	6963904	81	9700809	35, 39
2832604	69, 71	3927500	96	4868060	84, 85	6963905	81	9700811	35, 39
2832605	69, 71	3927600	96	4871300	17	6963906	81	9700901	36, 40
2832606	69, 71	3927700	96, 121	4871400	17	6970400	47	9700903	36, 40
2832607	69, 71	3927800	96, 121	4871500	15	6970401	44, 46, 47	9700905	36, 40
2832608	69, 71	3930000	93	4871600	15	6970500	47	9701001	36, 40
2834800	71	3930001	90, 92, 93	4878600	69	6970501	47	9701003	36, 40
2834801	71	3930020	93	4880000	17	6970600	47	9701005	36, 40
3030000	70	3930021	93	4880100	15	6970601	47	9716001	36, 40
3030001	70	3944300	89	4880200	17	6971400	47	9716003	36, 40
3030002	70	3944301	89	4880300	16, 17	6971401	47	9716005	36, 40
3030003	70	3944700	98	4880400	12, 15	6971500	47	9724500	121
3030004	70	3944701	98	4882100	56, 58, 59	6971501	46, 47	9724501	121
3030005	70	3945000	89	4882200	52, 54, 55	6971600	47	9724502	121
3707900	94	3945001	88, 89	4882300	63	6971601	47	9725200	120
3746700	105, 113	3945020	89	4882400	60, 62, 63	6973300	120	9725201	120
3746701	82, 105, 113	3945021	89	4882803	64, 66, 72, 104	6973301	120	9725202	120
3746702	90, 92, 105, 113	3955200	72, 73	4882804	64, 72, 104	6973302	120	9725203	120
3746703	105, 113	3955201	73	4882805	104	6986400	44, 46, 103	9725204	120
3746704	105, 113	3955202	73	4882806	104	6986401	103	9725205	120
3746710	113	3955220	73	4892900	71	6986402	103	9725206	120
3746711	74, 82, 105, 113	3955222	73	4965901	69	6986403	103	9743201	71
3746712	105, 113	3955400	72, 73	5248300	96	6986500	46	9743203	118
3746714	105, 113	3955401	73	6071300	17	6986501	103	9743204	118
3747000	84	3955402	73	6071400	17	6986502	103	9743205	71
3776002	94	3955420	73	6071500	15	6986503	103	9743207	69
3780300	105, 114, 115	3955421	73	6071600	15	6986601	103	9743208	69
3780301	105, 115	3955422	73	6080000	17	6986602	103	9743209	69
3780302	105, 115	3970000	86, 87	6080100	15	6986603	100, 103	9743210	69
3780303	105, 115	3970001	82, 86, 87	6080200	17	6987300	120	9743211	118
3780304	105, 115	3970002	86, 87	6080300	17	6987301	120	9743212	118
3780305	105, 115	3970003	86, 87	6080400	15	6987302	120	9743213	71, 118
3780310	81	3970004	87	6082100	59	7053501	97, 98	9743214	71, 118
3780311	81	3970020	87	6082200	55	7099000	99	9750400	29, 37
3780312	81	3970021	87	6924900	73, 79, 95	7271300	17	9750401	29, 37
3780313	81	3970022	87	6925700	73, 79, 95	7271400	17	9750402	29, 37
3780314	81	3970023	87	6925800	79	7271500	15	9750403	29, 37
3780315	81	3970024	87	6926000	73, 79, 95	7271600	15	9750404	29, 37
3780316	81	3975500	95	6938100	79	7280000	17	9750500	29, 37
3780317	81	3975501	95	6938200	79	7280100	15	9750501	29, 37
3780400	105, 115	3975502	80	6938202	79	7280200	17	9750502	29, 37
3780401	105, 114, 115	3975503	80	6938203	79	7280300	17	9750503	29, 37
3780402	76, 105, 115	3975504	80	6938204	79	7280400	15	9750504	29, 37
3784000	76, 114	3975600	95	6938205	79	7282100	59	9750505	29, 37
3811101	113	3975601	95	6942003	90, 91, 92, 95	7282200	55	9750600	29, 37
3811102	113	3975602	76, 80	6961300	73	7282300	63	9750601	29, 37



Index by Catalog Number

Catalog Number	Page Number	Catalog Number	Page Number	Catalog Number	Page Number	Catalog Number	Page Number	Catalog Number	Page Number
9750602	29, 37	9847604	101	9849001	102	9852304	119	9919003	107
9750603	29, 37	9847605	101	9849002	102	9852305	119	9919004	107
9750604	29, 37	9847700	101	9849003	102	9852309	119	9919100	111
9750605	29, 37	9847701	101	9849004	102	9852310	119	9919101	111
9774500	15	9847702	101	9849005	102	9852311	119	9919102	111
9808300	117	9847703	101	9849100	102	9852315	119	9919103	111
9808310	118	9847704	101	9849101	102	9852316	119	9919104	111
9808400	117	9847705	101	9849102	102	9852317	119	9919105	111
9808500	117	9847800	101	9849103	102	9852321	119	9920301	107, 109, 111, 112
9808700	117	9847801	101	9849104	102	9852322	119	9920304	107, 109, 111
9808800	117	9847802	101	9849105	102	9852323	119	9920306	107, 109, 111, 112
9808900	117	9847803	101	9849600	102	9852403	119	9920307	107, 109, 111
9809100	117	9847804	101	9849601	102	9852404	119	9920310	107, 109, 111, 112
9809200	117	9847805	101	9849602	102	9852405	119	9920311	107, 109, 111
9809300	117	9847900	101	9849603	102	9852409	119	9920312	107, 109, 111, 112
9809700	117	9847901	101	9849604	102	9852410	119	9920313	107, 109, 111
9827900	117	9847902	101	9849605	102	9852411	119	9938600	116
9828000	117	9847903	101	9849700	102	9852415	119	9942402	51
9833703	119	9847904	101	9849701	102	9852416	119	9942403	51
9833705	119	9847905	101	9849702	102	9852417	119	9942502	48, 50, 51
9833709	119	9848000	101	9849703	102	9853400	117	9942503	51
9833710	119	9848001	101	9849704	102	9854200	118	9942602	51
9833711	119	9848002	101	9849705	102	9857700	117	9942603	51
9833715	119	9848003	101	9849800	20, 23, 102	9860401	35, 39	9969400	102
9833716	119	9848004	101	9849801	102	9860403	35, 39	9969401	102
9833717	119	9848005	101	9849802	102	9860405	35, 39	9969402	102
9834004	120	9848100	101	9849803	102	9860501	35, 39	9969403	102
9834005	120	9848101	101	9849804	102	9860503	35, 39	9969404	102
9834006	120	9848102	101	9849805	102	9860505	35, 39	9969405	102
9834008	120	9848103	101	9849900	102	9860601	32, 34, 35, 39	9969500	102
9838600	105	9848104	101	9849901	102	9860603	35, 39	9969501	102
9840400	24	9848105	101	9849902	102	9860605	35, 39	9969502	102
9840401	24	9848200	101	9849903	102	9900000	105, 110, 111	9969503	102
9840402	24	9848201	101	9849904	102	9900100	20, 23, 64, 105, 111	9969504	102
9840403	24	9848202	101	9849905	102	9900200	48, 50, 105, 111	9969505	102
9840500	24	9848203	101	9851100	118	9900300	105, 111	9969600	42, 102
9840501	24	9848204	101	9851500	118	9900400	42, 105, 111	9969601	102
9840502	24	9848205	101	9851800	120	9900500	105, 111	9969602	102
9840503	24	9848300	101	9851801	120	9900600	105, 111	9969603	102
9840600	20, 23, 24	9848301	101	9851802	120	9900700	42, 105, 111	9969604	102
9840601	24	9848302	101	9851803	120	9900800	105, 111	9969605	102
9840602	24	9848303	101	9851804	120	9901000	14, 26, 44, 46, 52, 54, 56, 58, 60, 62, 64, 66, 105, 107	9969700	102
9840603	24	9848304	101	9851805	120	9901100	20, 23, 105, 106, 107	9969701	102
9840800	24	9848305	101	9851806	120	9901200	46, 105, 107	9969702	102
9840801	24	9848400	101	9852003	119	9901300	105, 107	9969703	102
9840802	24	9848401	101	9852004	119	9901400	105, 107	9969704	102
9840803	24	9848402	101	9852005	119	9901500	105, 107	9969705	102
9847100	12, 16, 100, 101	9848403	101	9852009	119	9901600	105, 107	9969800	102
9847101	101	9848404	101	9852010	119	9901700	105, 107	9969801	102
9847102	101	9848405	101	9852011	119	9901800	105, 107	9969802	102
9847103	101	9848500	102	9852015	119	9902000	12, 14, 16, 26, 72, 105, 109	9969803	102
9847104	101	9848501	102	9852016	119	9902100	105, 109	9969804	102
9847105	101	9848502	102	9852017	119	9902200	46, 105, 108, 109	9969805	102
9847200	101	9848503	102	9852021	119	9902300	105, 109	9970400	43
9847201	101	9848504	102	9852022	119	9902400	105, 109	9970401	43
9847202	101	9848505	102	9852023	119	9903000	105, 109	9970500	43
9847203	101	9848600	102	9852103	119	9903100	42, 105, 108, 109	9970501	43
9847204	101	9848601	102	9852104	119	9903200	105, 108, 109	9970600	42, 43
9847205	101	9848602	102	9852105	119	9903300	105, 109	9970601	43
9847300	101	9848603	102	9852109	119	9903400	105, 109	9970700	43
9847301	101	9848604	102	9852110	119	9904000	84, 105, 110, 111	9970701	43
9847302	101	9848605	102	9852111	119	9904100	105, 111	9970800	43
9847303	101	9848700	102	9852115	119	9904200	72, 105, 111	9970801	43
9847304	101	9848701	102	9852116	119	9904300	84, 105, 111	9972400	103
9847305	101	9848702	102	9852117	119	9904300	105, 111	9972500	48, 50, 103
9847400	14, 101	9848703	102	9852121	119	9904400	105, 111	9972600	103
9847401	101	9848704	102	9852122	119	9904500	72, 105, 111		
9847402	101	9848705	102	9852123	119	9905000	105, 107		
9847403	101	9848800	26, 102	9852203	119	9905100	105, 107		
9847404	101	9848801	102	9852204	119	9905200	105, 107		
9847405	101	9848802	102	9852205	119	9905300	105, 107		
9847500	101	9848803	102	9852209	119	9906000	105, 109		
9847501	101	9848804	102	9852210	119	9906100	105, 109		
9847502	101	9848805	102	9852211	119	9906200	105, 109		
9847503	101	9848900	102	9852215	119	9906300	105, 109		
9847504	101	9848901	102	9852216	119	9907000	105, 112		
9847505	101	9848902	102	9852217	119	9907100	105, 112		
9847600	101	9848903	102	9852221	119	9910000	109		
9847601	101	9848904	102	9852222	119	9919000	107		
9847602	101	9848905	102	9852223	119	9919001	107		
9847603	101	9849000	102	9852303	119	9919002	107		



Protector® Laboratory Fume Hoods & Enclosures

Conversion Factors

To Convert From	To	Multiply By
Centimeters	Inches	0.39370079
Cubic Feet	Liters	28.31605
Cubic feet/minute	Liters/second	0.4719342
Cubic meters/minute	Liters/minute	999.972
Feet	Centimeters	30.48
Feet/minute	Meters/second	0.00508
Foot candles	Lux	10.764
Gallons	Liters	3.785306
Gallons/second	Liters/minute	227.1183
Horsepower	BTU/hour	2547.16
Horsepower	Watts	746
Inches	Centimeters	2.54
Inches of H ₂ O (4° C)	Dynes/square centimeter	2490.82
Inches of H ₂ O (4° C)	Inches of Hg (32° F)	0.0735539
Kilograms	Pounds	2.2046226
Kilowatts	BTU/hour	3414.43
Liters	Gallons	0.2641794
Lux	Foot candles	0.0929
Meters/second	Feet/minute	196.85039
Milliliters	Ounces	0.03381497
Millimeters	Inches	0.039370079
Millimeters of Hg (0° C)	Pounds/square inch	0.0193368
Ounces	Liters	0.029572702
Pounds	Kilograms	0.45359237
Square Feet	Square Meters	0.09290304
Square Meters	Square Feet	10.763910
Watts	BTU/hour	3.41443

Temperature

$$^{\circ}\text{F} = 9/5 \text{ } ^{\circ}\text{C} + 32$$

$$^{\circ}\text{C} = 5/9 (\text{ } ^{\circ}\text{F} - 32)$$

Contact Labconco at 800-821-5525 or 816-333-8811 for more information about these quality products for your laboratory.



Biological Safety Cabinets, Enclosures and Clean Benches



Balance and Bulk Powder Enclosures



Nanotechnology Enclosures



Laboratory Animal Research Enclosures



Glove Boxes



Glassware Washers



Water Purification Systems



Freeze Dry Systems



Centrifugal Concentrators and Cold Traps



Multiple Sample Evaporation Systems



Agricultural Chemistry Products



Laboratory Carts and Benches



Blood Drawing Chairs



Vacuum Desiccators



Density Gradient Fractionators



Labconco Corporation 8811 Prospect Avenue • Kansas City, Missouri 64132-2696
 800-821-5525 • 816-333-8811 • FAX: 816-363-0130 • E-Mail: labconco@labconco.com • Home Page: www.labconco.com