

Installation 2 requires a base anchor and Simpson's CMST strap. A concealed connection can be designed between foundation and beam. The minimum inside diameter of the hollow column must be 3/4" for the CMST strap and a minimum base opening diameter of approximately 7" is required for the LTT/HTT or HDA base anchors. Consult the column manufacturer for minimum column opening diameters.

**INSTALLATION No. 2:**

- Select the appropriate strap and base anchor for the required uplift load from the table.
- Install base anchor:
  - a. Mark slab for center location of column.
  - b. Drill hole to the specified diameter and depth. See Table 2.
  - c. Clean hole and add Simpson's Epoxy-Tie. See Figures 1 through 6 on page 1.
  - d. Insert the required A307 threaded rod at the specified embedment depth.
  - e. Allow epoxy to cure.
- Attach base anchor to threaded rod and tighten nut after Epoxy-Tie has cured.
- Cut length of strap as required. Add an additional 1 1/2" for "end distance".
- Overlap CMST strap with strap of base anchor:
  - a. Mark a 1 1/2" distance from the end of the CMST strap. This is your end distance clearance. From the end distance, mark strap to match the location of base anchor stud bolts.
  - b. Drill strap bolt holes size and quantity as shown in Table 2.
  - c. Attach strap to base anchor with the required size and quantity of machine bolts (A307 bolts minimum).
- Set column in place and pull strap taut. While strap is held taut, fasten strap to beam with fasteners shown in table.

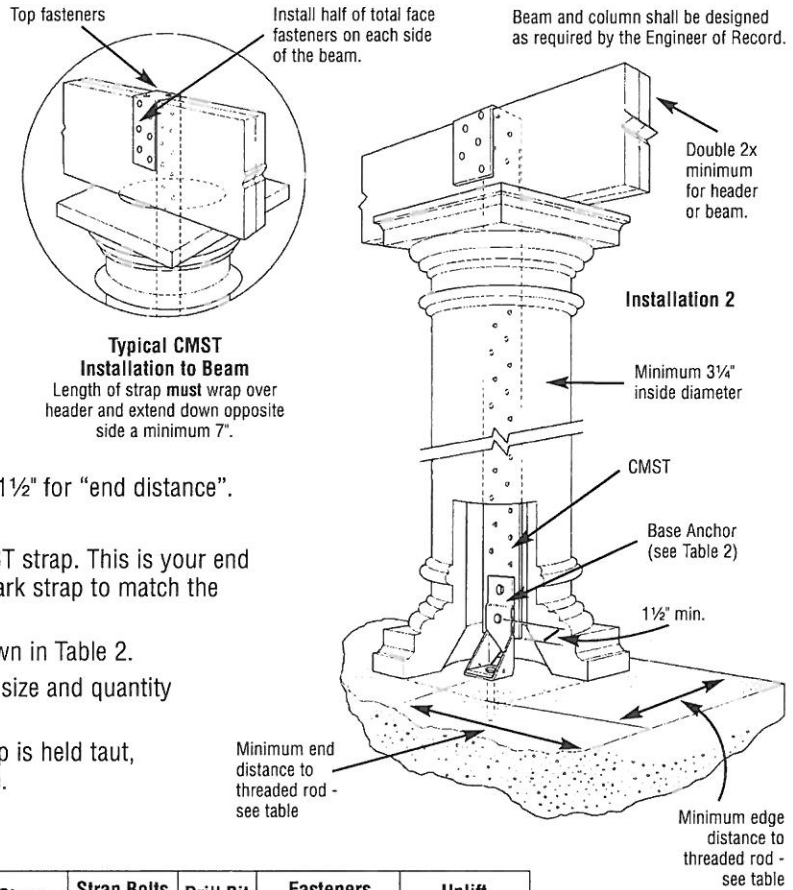

**TABLE 2 — Allowable Uplift Loads**

Base Anchor Model No.	Base Anchor Dia.	Anchor Drill Bit Dia.	Min. Embed.	Min. Anchor Length	Min. End Dist.	Min. Edge Dist.	Strap Model No.	Strap Bolts		Drill Bit Dia. (Strap)	Fasteners		Uplift	
								Qty	Dia.		Face (Total)	Top	100	(133 & 160)
LTT20B	3/4	7/8	6 3/4	8 3/4	10 1/8	5	CMST14	2	1/2	9/16	4-10d	2-10d	1750	1750
MTT28B	3/4	7/8	6 3/4	8 3/4	10 1/8	5	CMST14	4	1/2	9/16	8-10d	2-10d	3630	4455
HD2A	5/8	3/4	5	7	7 1/2	4	CMST14	2	5/8	1 1/16	4-10d	2-10d	2775	2775
HD5A	5/8 or 3/4	7/8	6 3/4	8 3/4	10 1/8	4	CMST14	2	3/4	1 3/16	8-10d	2-10d	3375	4010
HD8A	7/8	1	7 3/4	9 3/4	11 5/8	6	CMST14	3	7/8	1 5/16	8-10d	2-10d	3430	4435
HD8A	7/8	1	7 3/4	9 3/4	11 5/8	6	CMST12	3	7/8	1 5/16	10-10d	2-10d	4865	6305
HD10A	7/8	1	7 3/4	9 3/4	11 5/8	6	CMST12	4	7/8	1 5/16	10-10d	2-10d	4865	6305

1. See Simpson Anchor Systems catalog for complete Epoxy-Tie installation details.
2. 10d nails are common nails.
3. Allowable loads have been increased for wind or earth quake loading with no further increase allowed.
4. Minimum concrete compressive strength is 2000 psi.

This bulletin is effective until January 31, 2007, and reflects information available as of August 1, 2004. This information is updated periodically and should not be relied upon after January 31, 2007; contact Simpson for current product information and limited warranty or see [www.strongtie.com](http://www.strongtie.com).

**SIMPSON STRONG-TIE COMPANY, INC.**

<b>Home Office</b> 4120 Dublin Blvd., Ste 400 Dublin, CA 94568 FAX: 925/833-1496	<b>Northwest USA</b> 5151 S. Airport Way Stockton, CA 95206 FAX: 209/234-3868	<b>Southwest USA</b> 260 N. Palm St Brea, CA 92821 FAX: 714/871-9167	<b>Southeast USA</b> 1720 Couch Dr McKinney, TX 75069 FAX: 972/542-5379	<b>Northeast USA</b> 2600 International St Columbus, OH 43228 FAX: 614/876-0636	<b>Eastern Canada</b> 5 Kenview Blvd. Brampton, Ontario L6T5G5 FAX: 905/458-7274	<b>Western Canada</b> 11476 Kingston St. Maple Ridge, B.C. V2X-0Y5 FAX: 604/465-0297
---	--	---	--	--	---	---

800-999-5099  
[www.strongtie.com](http://www.strongtie.com)

© Copyright 2004 Simpson Strong-Tie Company Inc.

Printed in the USA

T-COLUMN04 8/04 exp. 1/07

Install hollow columns after the concrete pour, eliminating the need to determine the column's exact location during layout. Uplift loads are achieved with a concealed connection using Simpson's Epoxy-Tie™ anchoring system.

**INSTALLATION No. 1:**

- Mark slab for center location of column.
- Drill hole to the specified diameter and depth. See Table 1.
- Clean hole and add Simpson Epoxy-Tie. See Figures 1 through 6 below.
- Insert the required A307 thread rod at the specified embedment depth and allow epoxy to cure.
- Drop an appropriate length of A307 thread rod down the hollow column.
- Tighten both anchor and rod into coupler and set the column in place.
- Install beam and connect as listed in the table.
- Consult an Engineer of Record for approval to drill through the beam.

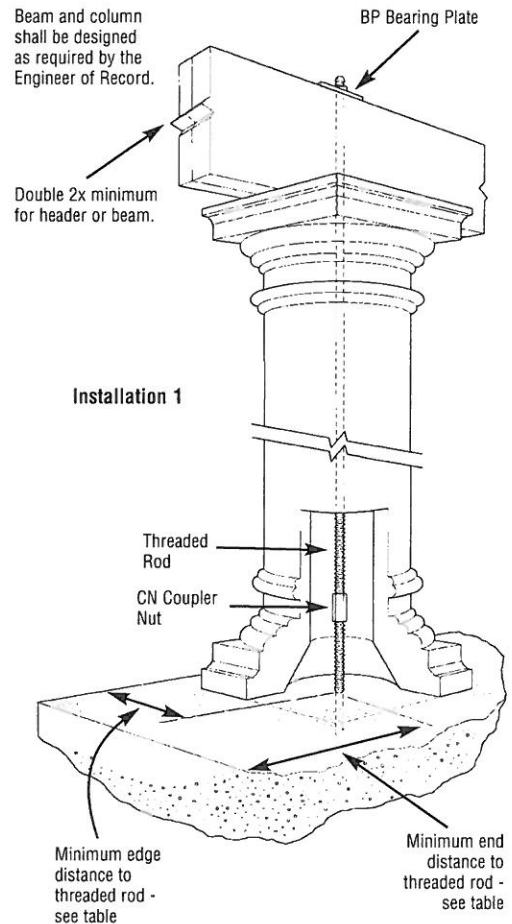
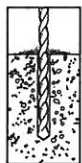

**TABLE 1 — Allowable Uplift Loads**

Anchor Dia.	Anchor Drill Bit Dia.	Min. Embed.	Min. Anchor Length	Min. End. Dist.	Min. Edge Dist.	ET22 Allowable Tension Loads F <sub>c</sub> =2000psi <sup>1,2</sup>		Beam Connection Model No.	Allowable Tension Loads <sup>1,2</sup>	
						(100%)	(133%)		(100%)	(133%)
1/2	5/8	4 1/4	6 1/4	6 3/8	3 1/2	2650	3535	BP 1/2	2345	2345
5/8	3/4	12	14	5	1 3/4	4040	5385	BP 5/8	3675	3675
3/4	7/8	6 3/4	8 3/4	10 1/8	5	6115	8155	BP 3/4	4400	4400
3/4	7/8	6 3/4	8 3/4	10 1/8	2 1/2	4785	6385	BP 3/4	4400	4400
7/8	1	7 3/4	9 3/4	11 1/8	6	7850	10465	BP 7/8	5195	5195
7/8	1	15 1/2	17 1/2	5	1 3/4	5835	7780	BP 7/8	5195	5195
1	1 1/8	9	11	13 1/2	6	8050	10730	BP 1	7100	7100
1	1 1/8	9	11	13 1/2	3 1/2	6805	9075	BP 1	6805	7100

1. Allowable loads for bond strength are based on a factor of safety of four on the average ultimate load.
2. Allowable loads at 133% have been increased for wind and earthquake loading with no further increase allowed.
3. For two pour condition with a maximum top pour thickness of 4", increase anchor length and embedment depth 4".
4. Coupler nut to meet same load specifications as threaded rod being connected.
5. Loads are based on grade A 307/SAE1018 thread rod.
6. BP loads are based on F<sub>c1</sub> equal to 625 psi. Allowable loads for other species must be adjusted to code.
7. Minimum concrete compressive strength is 2000 psi.
8. See Optional Installation.

**Installation into Concrete and Grout Filled CMU**



1. Drill—Drill hole to specified diameter and depth.

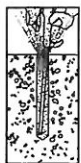

2. Clean—Remove dust from hole with oil-free compressed air. Clean with nylon brush and blow out remaining dust. **Note:** Dust left in hole can reduce the adhesive's holding capacity.

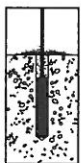

3. Cut open top of cartridge

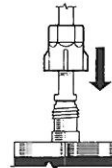

4. Attach clean mixing nozzle.

5. Fill—Dispense bead of adhesive off to the side to check for proper mixture (a uniform gray color) before using. Fill hole halfway, starting from bottom of hole to prevent air pockets. Withdraw nozzle as hole fills up.

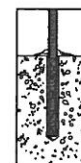

6. Insert—Anchors must be clean and oil free. Insert anchor, turning slowly until the anchor contacts the bottom of the hole. Do not disturb during cure time.