

Lot 1
(Extension No. 2)
Existing Hooters
Restaurant

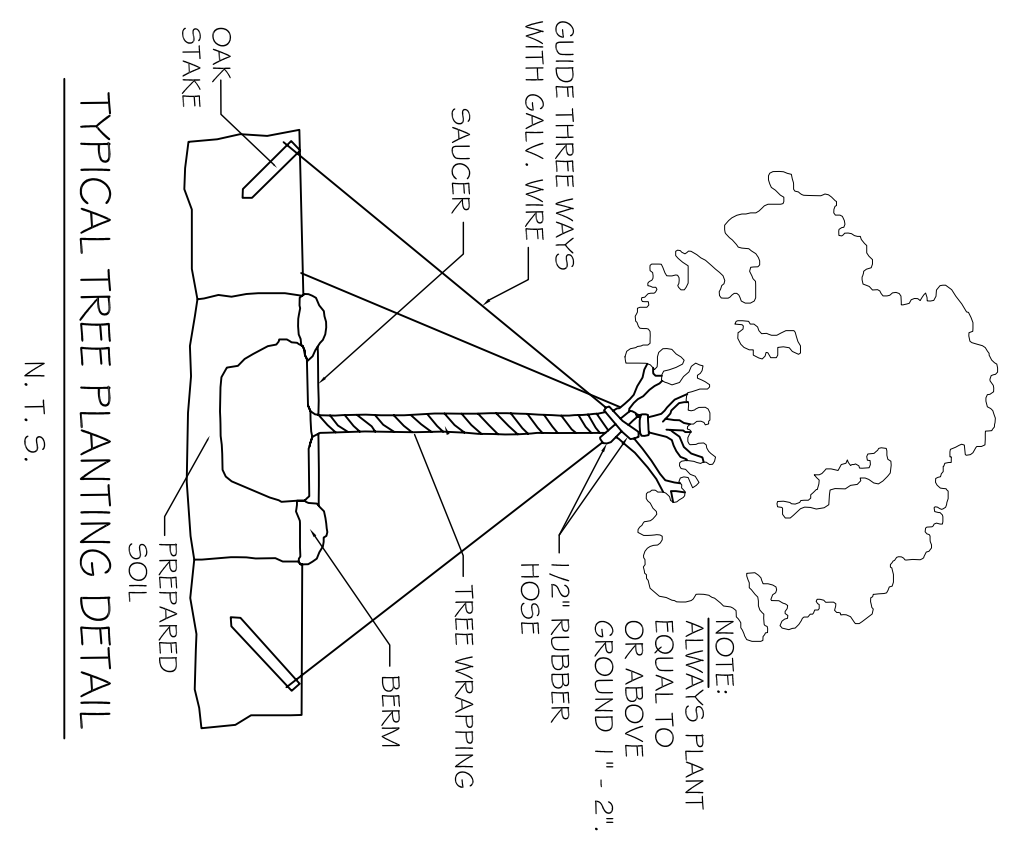

PROPERTY LINE N 00°10'58\"/>

SITE LANDSCAPING PLAN
SCALE: 1\"/>

REVISIONS		DATE
#	DESCRIPTION	

LAQUINTA INNS & SUITES
507 CONSTITUTION DRIVE
WEST MONROE, LOUISIANA 71292

JOB No: 2196 DATE: 04-15-2014
DRAWN BY: JTL CHECKED BY: CKD

DAMMON ENGINEERING, INC.
Architects & Engineers

CHIEF ENGINEER: BRIAN MISTICH, P.E.
CHIEF ARCHITECT: KEVIN KINCHEN
554 OLD SPANISH TRAIL
SLIDELL, LA 70458

dammoneengineering.com
dammoneng@bellsouth.net
PHONE: 985-649-5832
FAX: 985-641-5990

SHEET No: 06 OF 53
C5
SITE LANDSCAPING PLAN