

UPLIFT CONNECTIONS- 110 MPH WINDS EXPOSURE "B"						
CONNECTION	FRAMING SPACING (in.)	ROOF SPAN (ft.)	U	L	S	NUM. OF 8d COM. NAILS OR 10d BOX NAILS IN EA. END OF 1-1/4"X20 GA. STRAP
ROOF ASSEMBLY TO WALL ASSEMBLY	16" O.C.	17	386	246	109R	4
WALL ASSEMBLY TO WALL ASSEMBLY	16" O.C.	17	386	246	109R	4
WALL ASSEMBLY TO FOUNDATION	16" O.C.	17	170	185	436	4

THERMAL COMPONENT CRITERIA (U-FACTOR AND R-VALUE)					
MAX. GLAZING U-FACTOR	MINIMUM INSULATION R-VALUE				
	CEILINGS	WALLS	FLOORS	BASEMENT WALLS	CRAWL SPACE WALLS
.75	R-26	R-13	R-11	R-5	R-5

WINDBORNE DEBRIS PROTECTION FASTENING SCHEDULE FOR WOOD STRUCTURAL PANELS			
FASTENER TYPE	FASTENER SPACING		
	PANEL SPAN ≤ 4 FOOT	4 FOOT PANEL SPAN ≤ 6 FOOT	6 FOOT PANEL SPAN ≤ 8 FOOT
2-1/2" #6 WOOD SCREWS	16"	12"	9"
2-1/2" #8 WOOD SCREWS	16"	16"	12"

JACK STUD REQUIREMENTS-FOR INTERIOR LOADBEARING WALLS													
HEADER SUPPORTING	HEADER SPAN (ft.)	ROOF SPAN (ft.)											
		12 FEET			24 FEET			36 FEET					
		3'	4.5'	5'	6.5'	3'	4.5'	5'	6.5'	3'	4.5'	5'	6.5'
NUMBER OF JACK STUDS REQUIRED													
ROOF AND CEILING	2	1	1	1	1	1	1	1	1	1	1	1	1
	4	1	1	1	1	1	1	1	1	1	1	1	1
	6	1	1	1	1	1	1	1	1	1	1	1	1
	8	1	1	1	2	1	1	2	2	2	2	2	2
	10	1	1	1	2	2	1	1	3	2	2	2	2
	12	1	1	1	2	2	2	1	3	2	2	2	2
	14	2	1	1	3	2	2	2	4	3	3	2	2
ROOF, CEILING, AND 1 CENTER BEARING FLR.	2	1	1	1	1	1	1	1	1	1	1	1	1
	4	1	1	1	2	1	1	3	2	2	2	2	
	6	2	1	1	3	2	2	4	3	3	2	2	
	8	2	2	1	4	3	3	5	4	4	3	3	
	10	2	2	2	5	4	4	7	5	5	4	4	
	12	3	2	2	6	5	5	9	6	6	5	5	
	14	3	2	2	7	6	6	11	7	7	6	6	
HEADER WIDTH-3"(2-2x), 4.5"(3-2x), 5", 6.5"(4-2x) EACH W/ 1/2" FLYWD. SPACER BETWEEN													

HEADER SPANS-FOR INTERIOR LOADBEARING WALLS				
HEADER SUPPORTING	SIZE	BLDG. WIDTH (ft.)		
		12	24	36
		SPANS (ft.-in.)		
ONE FLOOR (CENTER BEARING)	(2)2x4S	4'-4"	3'-1"	2'-6"
	(2)2x6S	6'-5"	4'-6"	3'-8"
	(2)2x8S	8'-1"	5'-9"	4'-8"
	(2)2x10S	9'-11"	7'-0"	5'-9"
	(2)2x12S	11'-6"	8'-1"	6'-7"
	(3)2x8S	10'-2"	7'-2"	5'-10"
	(3)2x10S	12'-5"	8'-9"	7'-2"
	(3)2x12S	14'-4"	10'-2"	8'-3"
	(4)2x8S	11'-6"	8'-3"	6'-9"
	(4)2x10S	14'-4"	10'-1"	8'-3"
2 FLOORS ONLY (CENTER BEARING)	(2)2x4S	2'-10"	2'-1"	1'-8"
	(2)2x6S	4'-2"	3'-1"	2'-6"
	(2)2x8S	5'-4"	3'-11"	3'-3"
	(2)2x10S	6'-6"	4'-9"	3'-11"
	(2)2x12S	7'-6"	5'-6"	4'-7"
	(3)2x8S	6'-8"	4'-10"	4'-0"
	(3)2x10S	8'-1"	6'-0"	4'-11"
	(3)2x12S	9'-5"	6'-11"	5'-9"
	(4)2x8S	7'-8"	5'-8"	4'-8"
	(4)2x10S	9'-4"	6'-10"	5'-8"
* MAX. SPAN EXCEEDS 16' (SPANS LIM. TO 16')				

HEADER SPANS-EXPOSURE B FOR EXTERIOR LOADBEARING WALLS		
HEADER SIZE	SPAN	NO. FULL HGT. STUDS REQ. AT EA. END
(2)2x4S	4'-7"	2
(2)2x6S	5'-6"	2
(2)2x8S	6'-1"	3
(2)2x10S	6'-8"	3
(3)2x8S	7'-1"	3
(3)2x10S	8'-3"	3
(3)2x12S	8'-8"	3
(4)2x8S	8'-7"	3
(4)2x10S	9'-6"	3
(4)2x12S	10'-0"	4
130 MPH WINDS-EXPOSURE "B" (TYP.) EACH W/ 1/2" PLYWD. SPACER BETWEEN		

NOTE:
1. BLDG. WIDTH IS MEASURED PERPENDICULAR TO THE RIDGE. FOR WIDTHS BETWEEN THOSE SHOWN, SPANS ARE PERMITTED TO BE INTERPOLATED.
2. ALL HEADERS SHALL HAVE SOLID BLOCKING.

JACK STUD REQ.-EXP. B FOR EXTERIOR LOADBEARING WALLS					
HEADER SUPPORTING	HEADER SPAN (ft.)	HEADER WIDTH			
		3"	4.5"	5"	6.5"
		NO. JACK STUDS REQ.			
ROOF AND CEILING	2	1	1	1	1
	4	1	1	1	1
	6	2	2	2	2
	8	2	2	2	2
	10	3	3	3	3
	12	3	3	3	3
	14	4	4	4	4
ROOF, CEILING, AND 1 CENTER BEARING FLOOR	2	1	1	1	1
	4	2	2	2	2
	6	2	2	2	2
	8	3	3	3	3
	10	4	4	4	4
	12	4	4	4	4
	14	5	5	5	5
HEADER WIDTH-3"(2-2x), 4.5"(3-2x), 5", 6.5"(4-2x) EACH W/ 1/2" PLYWD. SPACER BETWEEN					

WALL SHEATH. OR CLAD. REQTS. FOR WIND LOAD-EXPOSURE "B"			
SHEATHING LOCATION	STUD SPAC.	MAX. NAIL SPAC. FOR 8d COM. NAILS OR 10d BOX NAILS (INCHES, O.C.)	
		E	F
INTERIOR ZONE	12" O.C.	6	12
	16" O.C.	6	12
	24" O.C.	6	12
PERIMETER EDGE ZONE	12" O.C.	6	12
	16" O.C.	6	12
	24" O.C.	6	12
130 MPH WINDS-EXPOSURE "B" (TYP.)			

WINDOWS IN BUILDINGS LOCATED IN WIND BORNE DEBRIS REGIONS SHALL HAVE GLAZED OPENINGS PROTECTED FROM WINDBORNE DEBRIS. WOOD STRUCTURAL PANELS WITH A MIN. THICKNESS OF 7/16" AND A MAX. SPAN OF 8 FEET SHALL BE PERMITTED FOR OPENING PROTECTION IN ONE AND TWO STORY BUILDINGS. PANELS SHALL BE PRECUT TO COVER THE GLAZED OPENINGS WITH ATTACHMENT HARDWARE PROVIDED.

HEADER NAILING SCHEDULE			
DESCRIPTION	NUM. OF COM. NAILS	NUM. OF BOX NAILS	SPACING
HEAD, TO HEAD, (FACE-NAILED)	8d	10d	6" O.C. EDGES/ 12" O.C. FIELD

NOTE:
ALL HEADERS SHALL HAVE SOLID BLOCKING

SILL or BOTTOM PLATE TO FND. CONNECTIONS RESISTING UPLIFT LOADS- 110 MPH WINDS EXP. "B"			
BOTTOM PLATE TO FND. ANCHOR BOLT CONNECTION RESISTING	FOUNDATION SUPPORTING	MAX. ANCHOR BOLT SPACING (in.)	
		8' END ZONES	INTERIOR ZONES
UPLIFT LOADS	1-3 STORIES	28	33

SILL or BOTTOM PLATE TO FND. CONNECTIONS RESISTING SHEAR LOADS- 110 MPH WINDS EXP. "B"			
BOTTOM PLATE TO FND. ANCHOR BOLT CONNECTION RESISTING	FOUNDATION SUPPORTING	MAX. ANCHOR BOLT SPACING (in.)	
		1/2" ANC. BOLTS	5/8" ANC. BOLTS
SHEAR LOADS	1-3 STORIES	30	45

ROOF SHEATH. OR CLAD. REQ. FOR WIND LOAD-EXP. B			
SHEATHING LOCATION	RAFTER/TRUSS SPAC.	MAX. NAIL SPAC. FOR 8d COM. NAILS OR 10d BOX NAILS (INCHES, O.C.)	
		E	F
INTERIOR ZONE	12" O.C.	6	12
	16" O.C.	6	12
	24" O.C.	6	12
PERIMETER EDGE ZONE	12" O.C.	6	12
	16" O.C.	6	6
	24" O.C.	6	6
130 MPH WINDS-EXPOSURE "B" (TYP.)			

ROOF UNDERLAYMENT APPLICATION

FOR ROOF SLOPES FROM TWO UNITS VERTICAL IN 12 UNITS HORIZONTAL (17-PERCENT SLOPE), UP TO FOUR UNITS VERTICAL IN 12 UNITS HORIZ. (33-PERCENT SLOPE), UNDERLAYMENT SHALL BE TWO LAYERS APPLIED IN THE FOLLOWING MANNER:

APPLY A 19 INCH STRIP OF UNDERLAYMENT FELT PARALLEL WITH AND STARTING AT THE EAVES, FASTENED SUFFICIENTLY TO HOLD IN PLACE. STARTING AT THE EAVE, APPLY 36 INCH WIDE SHEETS OF UNDERLAYMENT, OVERLAPPING SUCCESSIVE SHEETS 19 INCHES, AND FASTENED SUFFICIENTLY TO HOLD IN PLACE.

FOR ROOF SLOPES OF FOUR UNITS VERTICAL IN 12 UNITS HORIZONTAL (33-PERCENT SLOPE) OR GREATER, UNDERLAYMENT SHALL BE ONE LAYER APPLIED IN THE FOLLOWING MANNER:

UNDERLAYMENT SHALL BE APPLIED SHINGLE FASHION, PARALLEL TO AND STARTING FROM THE EAVE AND LAPPED 2 INCHES, FASTENED SUFFICIENTLY TO HOLD IN PLACE. END LAPS SHALL BE OFFSET BY 6 FEET.

SHINGLE APPLICATION/FASTENING

ASPHALT STRIP SHINGLES SHALL HAVE A MINIMUM OF SIX FASTENERS PER SHINGLE WHERE THE ROOF IS IN ONE OF THE FOLLOWING CATEGORIES:

1. THE BASIC WIND SPEED IS 110 MPH OR GREATER AND THE EAVE IS 20 FEET OR HIGHER ABOVE GRADE.
2. THE BASIC WIND SPEED IS 120 MPH OR GREATER.
3. SPECIAL WIND ZONES.

UPLIFT CONNECTIONS

ROOF ASSEMBLY TO WALL ASSEMBLY:

UPLIFT CONNECTIONS SHALL BE FROM RAFTER OR TRUSS TO WALL STUD. WHEN RAFTERS OR TRUSSES ARE NOT LOCATED DIRECTLY ABOVE STUDS, RAFTERS SHALL BE ATTACHED TO THE WALL PLATE AND THE WALL TOP PLATE SHALL BE ATTACHED TO THE WALL STUD WITH UPLIFT CONNECTIONS. UPLIFT CONNECTIONS SHALL BE IN ACCORDANCE WITH TABLE.

WALL ASSEMBLY TO WALL ASSEMBLY:

STORY TO STORY UPLIFT CONNECTIONS FROM UPPER STORY WALL STUD TO LOWER STORY WALL STUD. WHEN UPPER STORY WALL STUDS ARE NOT LOCATED DIRECTLY ABOVE LOWER WALL STUDS, THE STUDS SHALL BE ATTACHED TO A COMMON MEMBER IN THE FLOOR ASSEMBLY BY UPLIFT CONNECTIONS. UPLIFT CONNECTIONS SHALL BE IN ACCORDANCE WITH TABLE.

WALL ASSEMBLY TO FOUNDATION:

FIRST FLOOR WALL STUDS SHALL BE CONNECTED TO THE FOUNDATION, SILL, PLATE, OR BOTTOM PLATE. A MINIMUM OF A 1-1/4" x 20 GA. ASTM A653 GRADE 33 STEEL STRAP SHALL BE NAILED TO THE WALL STUDS AND HAVE A MINIMUM EMBEDMENT OF 7 INCHES IN CONCRETE FOUNDATIONS AND SLABS-ON-GRADE. 15 INCHES IN MASONRY BLOCK FOUNDATIONS, OR BE LAPPED UNDER THE BOTTOM PLATE, 3 INCH SQUARE WASHERS SHALL BE USED ON THE ANCHOR BOLTS AND ANCHOR BOLT SPACINGS SHALL NOT EXCEED THE REQUIREMENTS. STEEL STRAPS EMBEDDED IN OR IN CONTACT WITH SLAB-ON-GRADE OR MASONRY BLOCK FOUNDATIONS SHALL BE HOT-DIPPED GALV. AFTER FABRICATION, OR MANUF. FROM G-185 OR Z450 GALV. STL. CONNECTIONS SHALL BE IN ACCORDANCE WITH TABLE.

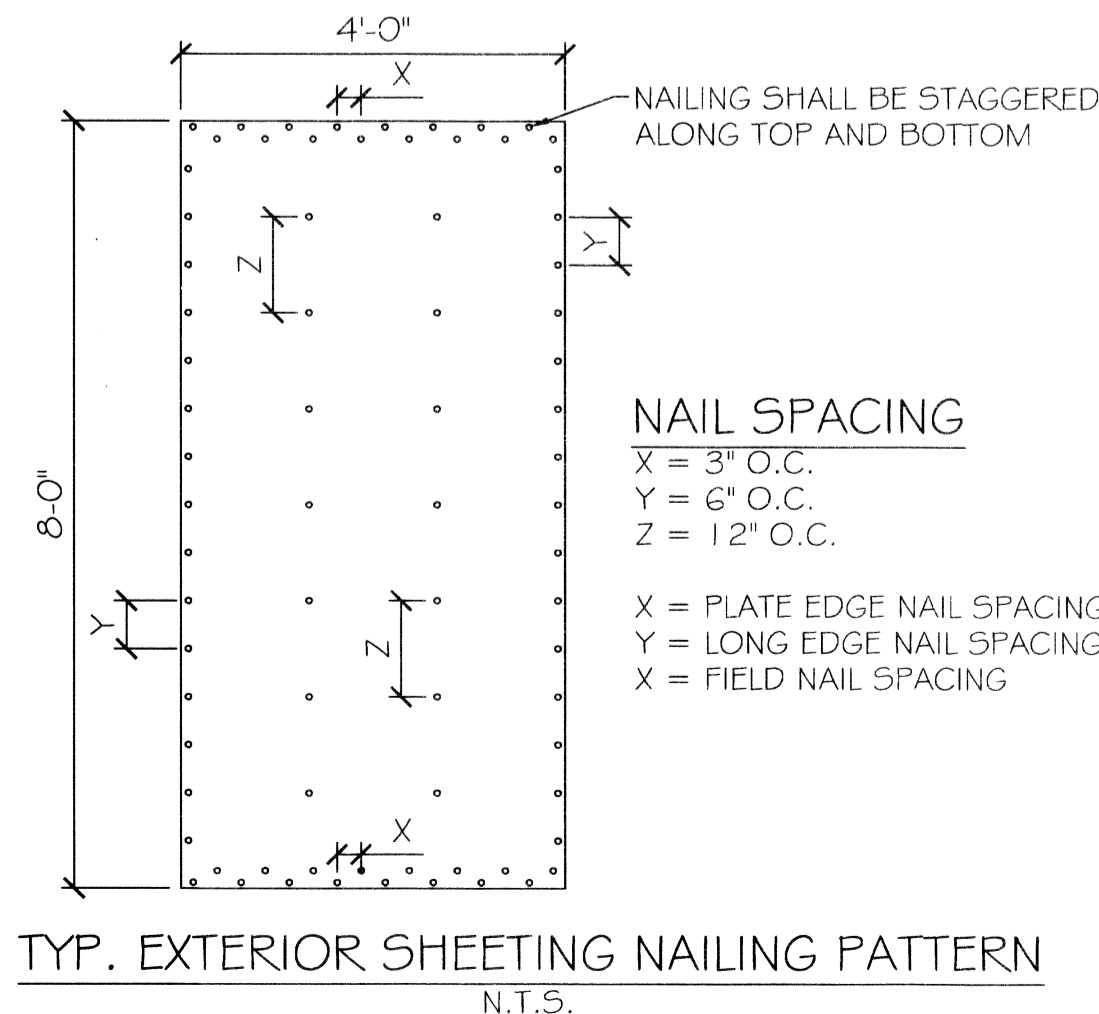

DESIGN CRITERIA:

THE CONSTRUCTION FOR SAID RESIDENCE, WHERE BASIC WIND SPEED IS 110 MILES PER HOUR, IS DESIGNED IN ACCORDANCE WITH: AMERICAN FOREST AND PAPER ASSOCIATION (AF&PA) WOOD FRAME CONSTRUCTION MANUAL FOR ONE AND TWO FAMILY DWELLINGS (WFCM) 2001 EDITION AS WELL AS THE INTERNATIONAL RESIDENTIAL CODE (IRC) 2003 EDITION

HOLDDOWNS

HOLD DOWNS ARE REQUIRED AT THE END OF EACH SEGMENTED SHEARWALL SEGMENT OR AT EACH END OF A PERFORATED SHEARWALL. WHEN FULL HEIGHT SHEARWALL SEGMENTS MEET AT A CORNER, A SINGLE HOLD DOWN SHALL BE PERMITTED TO BE USED TO RESIST THE OVERTURNING FORCES IN BOTH DIRECTIONS WHEN THE CORNER FRAMING IN THE ADJOINING WALLS IS FASTENED TOGETHER TO TRANSFER THE UPLIFT LOAD. SEE CORNER HOLD DOWN DETAIL.

NOTE:
PRE FABRICATED ROOF, FLOOR, WALLS, BEAMS AND COLUMNS PROVIDED BY OTHERS.

SEE SHEET A-2 FOR ALL WALL, FLOOR/ CEILING AND ROOF/ CEILING ASSEMBLY RATINGS AS REQUIRED BY LOCAL CODE AND ORDINANCES FOR BUILDING TYPE AND RATING SELECTED.

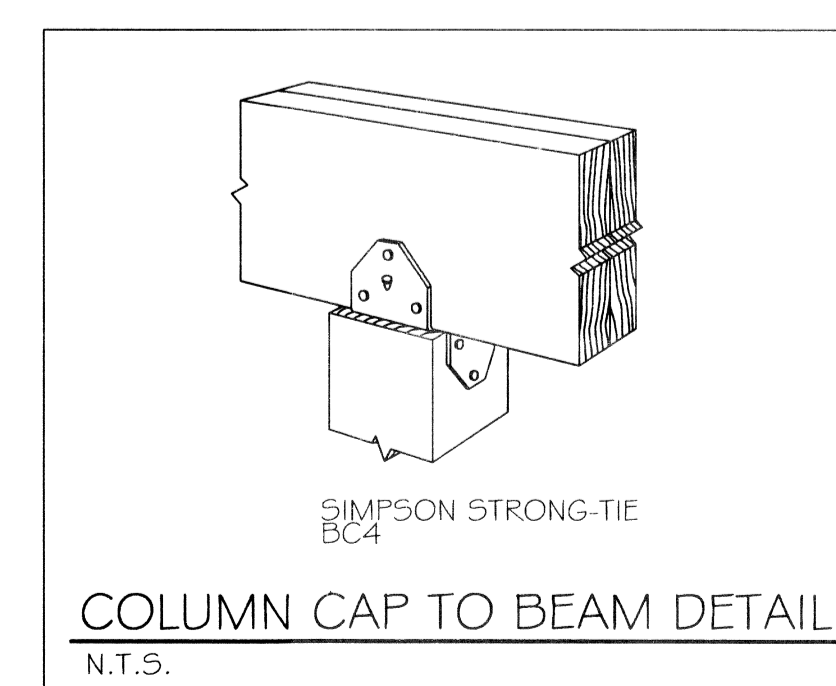
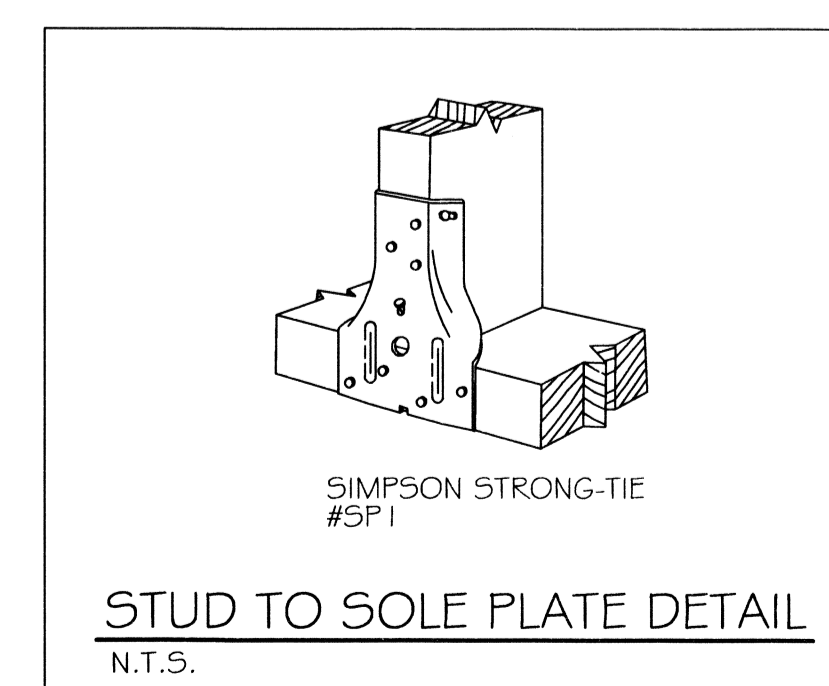
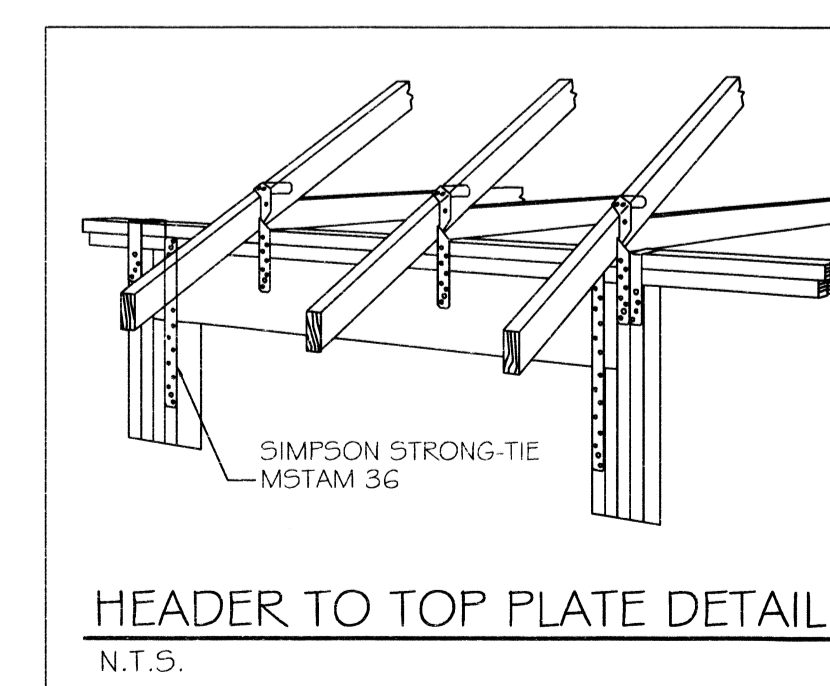
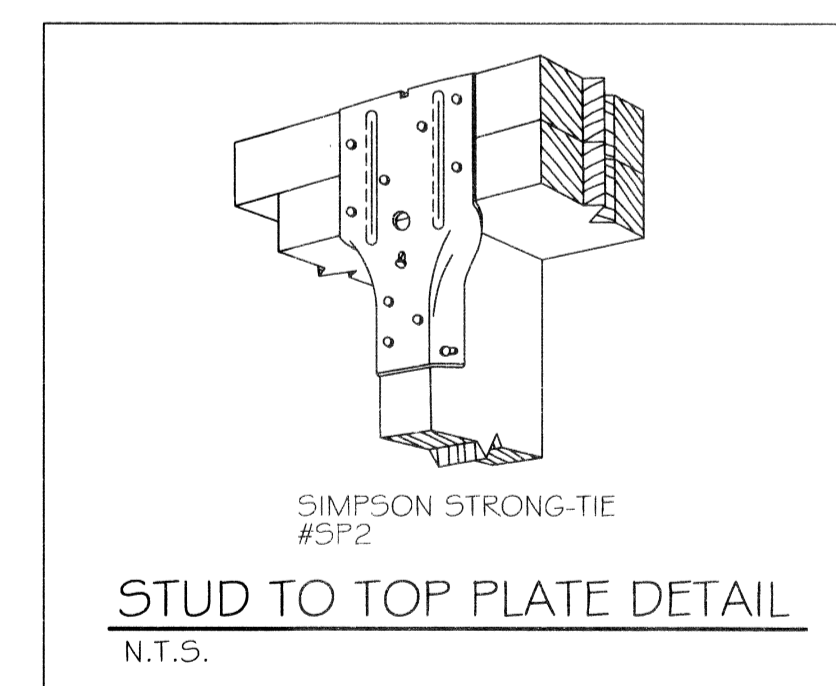
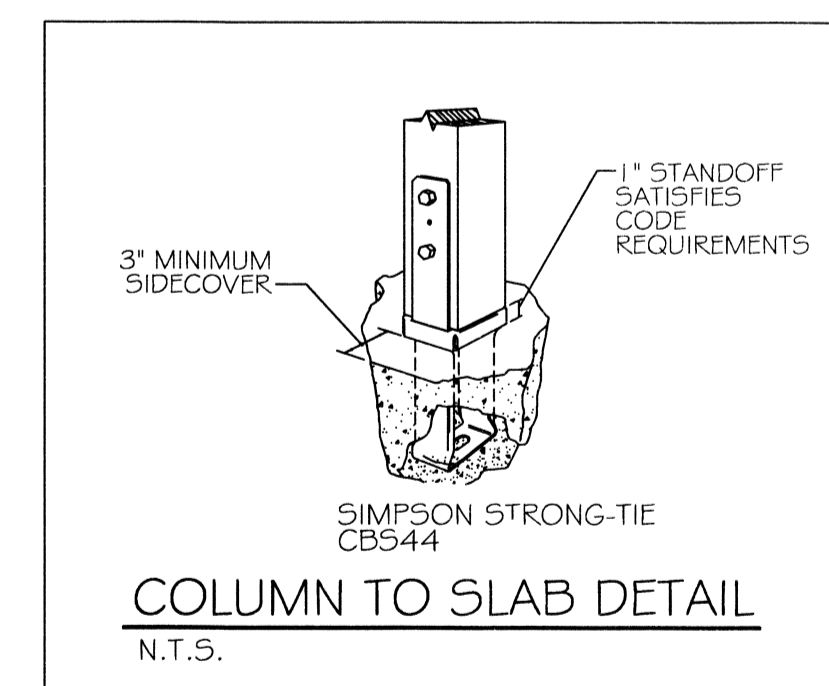
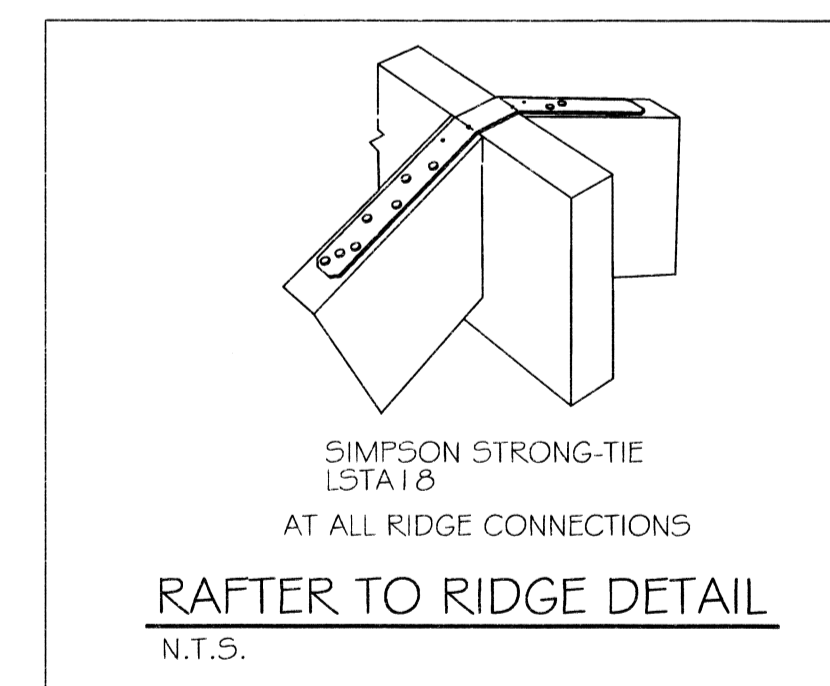
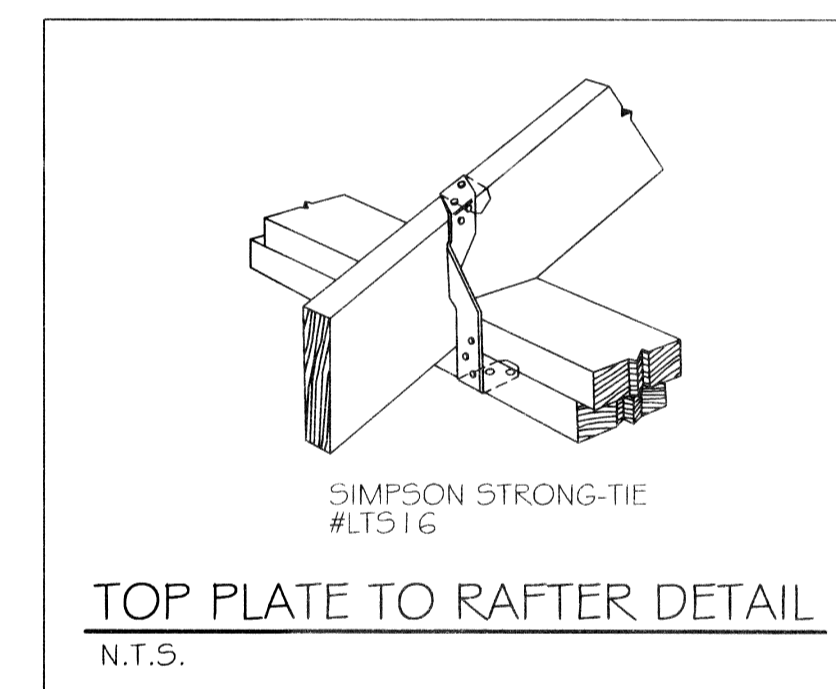
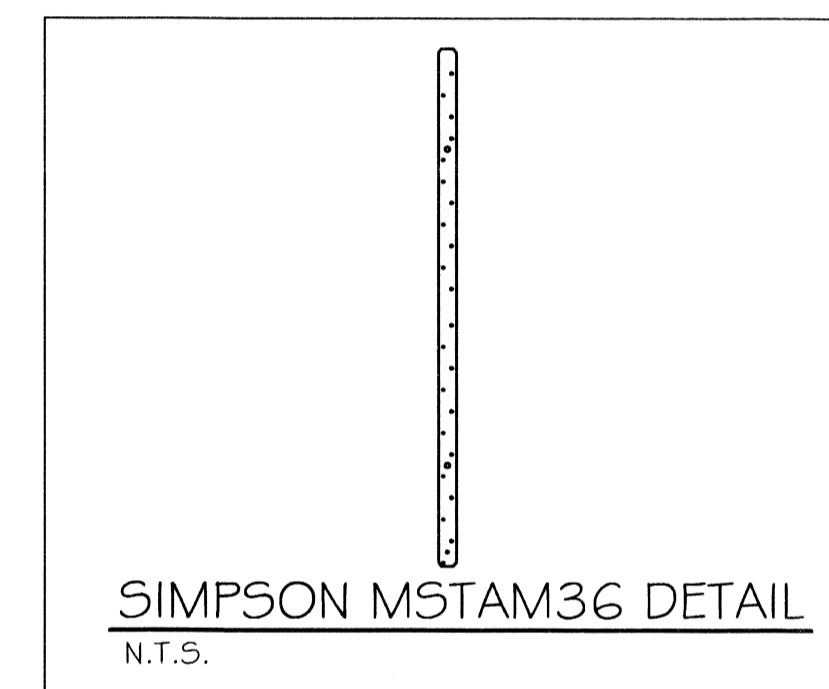
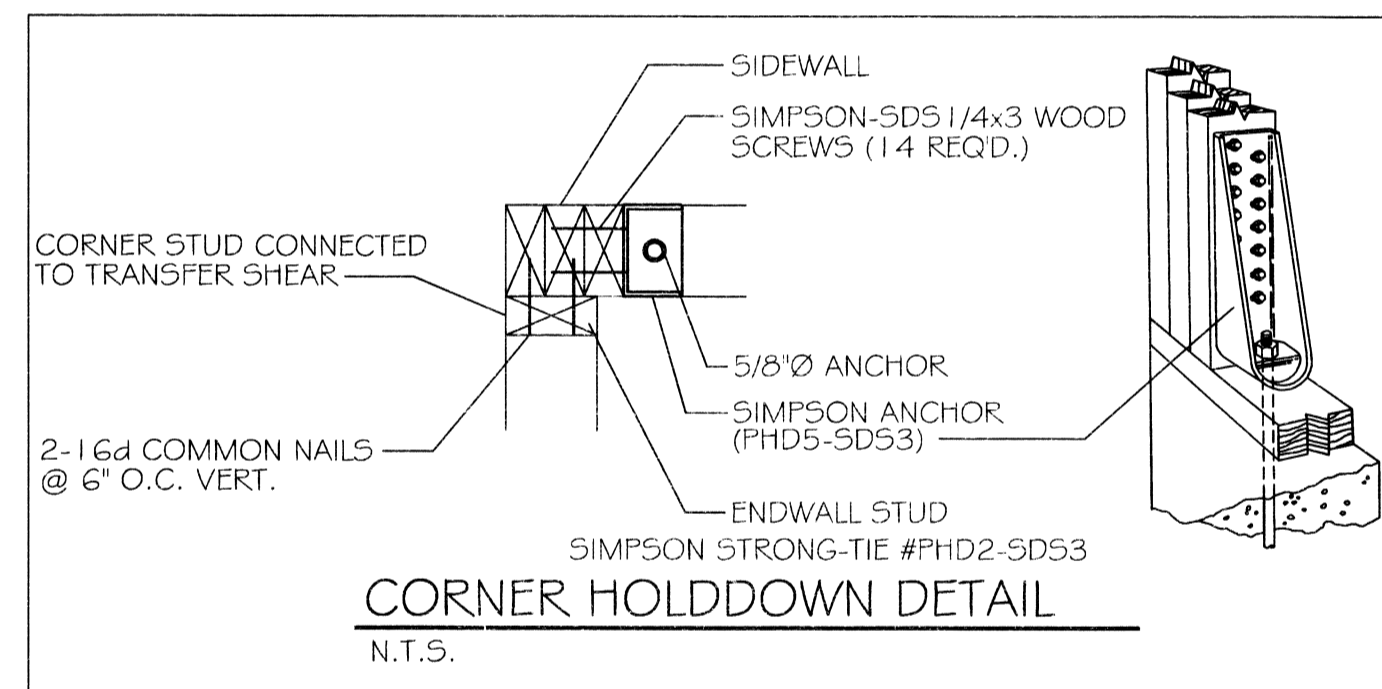
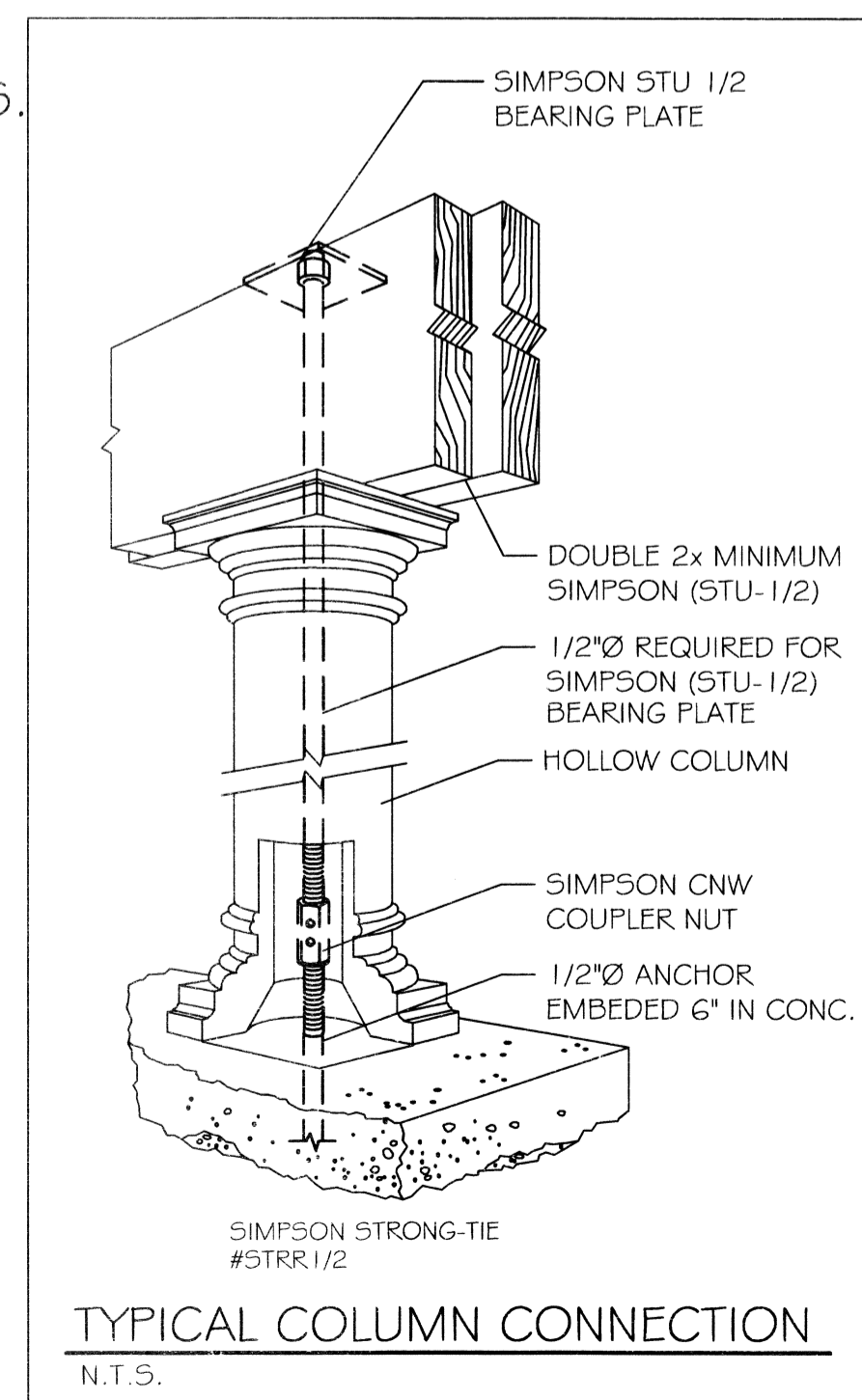

dammoneng.com
dammoneng@earthlink.net
PHONE: 985-649-5832
FAX: 985-641-6960

CHIEF ENGINEER: BRIAN METCHIE, P.E.
CHIEF ARCHITECT: KEVIN KUCHEN
554 OLD SPANISH TRAIL
BOULDER, LA 70805

LAQUINTA INNS & SUITES

SUB CONTRACTOR FILE
WEST-TALUKA, LA 70804 7/1/2012

REVISIONS

NO.	DESCRIPTION	DATE	BY

JOB No:

2196

DATE:

02-03-2014

DRAWN BY:

JTL

CHECKED BY:

CKD

SHEET No.

18 OF 53

A10