

FEATURES & SPECIFICATIONS

INTENDED USE — Provides a minimum of 90 minutes of illumination for the rated wattage upon loss of AC power. Ideal for applications requiring attractive unit equipment with quick installation. **Certain airborne contaminants can diminish integrity of acrylic and/or polycarbonate.** [Click here for Acrylic-Polycarbonate Compatibility table for suitable uses.](#)

CONSTRUCTION — White, compact, low-profile contemporary design. Engineering-grade thermoplastic housing is impact-resistant, scratch-resistant and corrosion-proof. UL94V-0 flame rating. UV-stable resin resists discoloration from natural and man-made light sources.

Low-profile, integrated test switch/pilot light. Easily visible bright red status indicator.

Unique track-and-swivel arrangement permits full range of direction of lamp head adjustment. Universal J-box mounting pattern. Tool-less access for maintenance.

OPTICS — Two LED lamp heads with polycarbonate lens, 12 series-parallel white LEDs each, provide redundant light sources to ensure emergency lighting performance. Typical LED lamp life is 10 years.

ELECTRICAL — Dual-voltage input capability (120/277V). Edge connector on printed circuit board ensures long-term durability.

Current-limiting charger maximizes battery life and minimizes energy consumption. Provides low operating costs.

Short-circuit protection — current-limiting charger circuitry protects printed circuit board from shorts.

Thermal compensation adjusts charger output to provide optimum charge voltage relative to ambient temperature.

Regulated charge voltage maintains constant-charge voltage over a wide range of line voltages. Prevents over/undercharging that shortens battery life and reduces capacity.

Filtered charger input minimizes charge voltage ripple and extends battery life.

AC/LVD reset allows battery connection before AC power is applied and prevents battery damage from deep discharge.

BATTERY: Sealed, maintenance-free nickel-cadmium battery delivers 90 minute capacity to emergency lamps. Two-state constant-current charge maximizes battery life and automatically recharges after battery discharge. Low-voltage disconnect prevents excessively deep discharge that can permanently damage the battery. Optional high-output battery available to power both local and optional LED remote lamp heads simultaneously.

Self-Diagnostics (SD- Option) Single multi-color LED indicator to display two-state charging, test activation and three-state diagnostic test. Test switch provides manual activation of 30-second diagnostic testing for on-demand visual inspection. Self-diagnostic testing for 30 seconds every 30 days, 30 minutes at 180-day interval, and 90 minutes annually. Diagnostic evaluation of LED light source, AC to DC transfer, charging and battery condition.

INSTALLATION — Ceiling- or wall-mount standard. Flexible conduit entry provision on top of the unit.

LISTINGS — UL damp location listed standard 50-104°F (10-40°C). Meets UL 924, NFPA 101 (current Life Safety Code), NEC and OSHA illumination standards.

Catalog Number
Notes
Type



Thermoplastic Emergency Light

ELM2 LED



LED Lamp Head
Ni-Cad Battery



WARRANTY — 5-year limited warranty. (Battery is prorated). Complete warranty terms located at www.AcuityBrands.com/CustomerResources/Terms_and_Conditions.aspx.

Note: Actual performance may differ as a result of end-user environment and application.

All values are design or typical values, measured under laboratory conditions at 25 °C.

Specifications subject to change without notice.

ORDERING INFORMATION

Lead times will vary depending on options selected. Consult with your sales representative.

Example: ELM2 LED

ELM2 Series	LED Lamp type	Housing	Options
ELM2	LED Two 1.5W/3.6V white LED	(blank) White B Black	HO High-output ni-cad battery for 6W remote capacity ¹ SD Self-diagnostics NOM Meets Mexican standards T20C California Title 20 Compliance ²

Accessories: Order as separate catalog number.

ELA Q L0304 SD	Single LED indoor remote head, white, self-diagnostics ^{3,4,5}	ELA Q L0304	Single LED indoor remote head, white ^{3,4,5}
ELA T Q L0304 SD	Twin LED indoor remote head, white, self-diagnostics ^{3,4,5}	ELA T Q L0304	Twin LED indoor remote head, white ^{3,4,5}
ELA QWP L0304 SD	Single LED weather-proof remote head, gray, self-diagnostics ^{3,4,5}	ELA QWP L0304	Single LED weather-proof remote head, gray ^{3,5}
ELA T QWP L0304 SD	Twin LED weather-proof remote head, gray, self-diagnostics	ELA T QWP L0304	Twin LED weather-proof remote head, gray ^{3,5}
ELA WG1	Wireguard, 15"W x 13-1/2"H x 6"D (See spec sheet ELA-WG)	ELAVS	Thermoplastic vandal shield ⁶

Notes

- Not available with NOM.
- See T20C compliant [product list](#). Only available with ELM2 LED, ELM2 LED HO SD and ELM2 LED B HO SD.
- Only available with HO option. See spec sheet [ELA Q LED](#).
- Also available in black. Add "B" after ELA to order black finish. Example: ELA B Q L0304 SD. See spec sheet [ELA Q LED](#).
- Only compatible with Quantum LED series.
- See spec sheet [ELA VS-VS2](#).

ELM2 LED QUANTUM® Thermoplastic Emergency Light

SPECIFICATIONS

Electrical				
Primary Circuit				
Typical LED life ¹	Supply voltage	Max amps	Max watts	HO/max watts
10 years	120	.04	1.44	2.88
	277	.03	1.44	2.88

BATTERY

Ni-Cad				
Voltage	Shelf life ²	Typical life ²	Maintenance ³	Optimum temperature ⁴
3.6	3 years	7-9 years	none	50-104°F (10-40°C)

- Based on continuous operation.
- At 77°F (25°C).
- All life safety equipment, including emergency lighting path of egress, must be maintained, serviced and tested in accordance with all National Fire Protection Association and local codes. Failure to perform the required maintenance, service or testing could jeopardize the safety of occupants and will void all warranties.
- Optimum ambient temperature range where unit will provide capacity for 90 minutes. Higher and lower temperatures affect life and capacity. Consult factory for detailed information.

Remote Output Capacity	
Standard unit	Unit/HO battery
NA	6W

MOUNTING

All dimensions are inches (centimeters).
Shipping weight: 4.0 lbs. (1.8 kgs.)

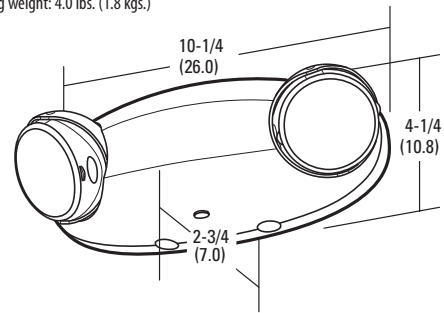

Mounting Plate

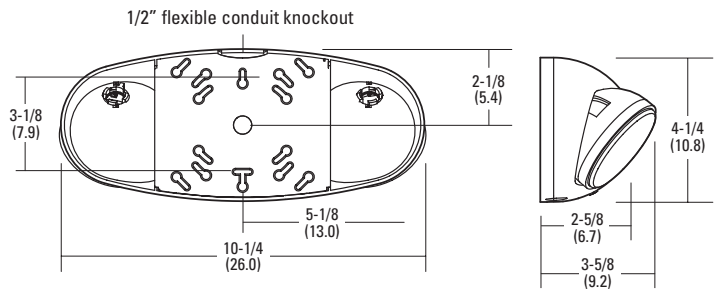

LAMP PHOTOMETRICS

QUANTUM LED SERIES – SINGLE COVERAGE

3W Total White LEDs

Using a single unit at a typical 7.5' mounting height delivers an average illuminance of 1.0 FC over a distance of 24' on a 3' path of egress and 18' on a 6' path of egress.

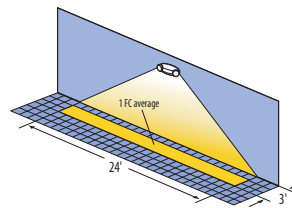

Example of single ELM2 LED unit illuminating a 3' path of egress

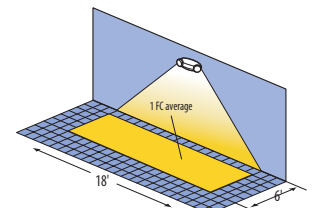

Example of single ELM2 LED unit illuminating a 6' path of egress

QUANTUM LED SERIES – MULTIPLE COVERAGE

3W Total White LEDs

Using multiple units at a typical 7.5' mounting height delivers 25' center-to-center spacing on a 3' path of egress and 20' center-to-center spacing on a 6' path of egress.

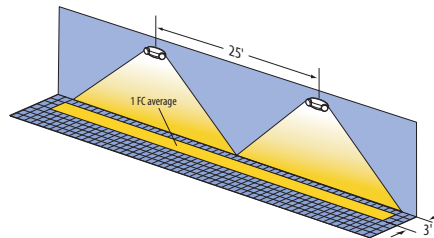

Example of multiple ELM2 LED units illuminating a 3' path of egress

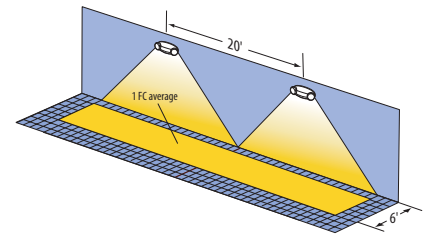

Example of multiple ELM2 LED units illuminating a 6' path of egress

EXTENDED RUN-TIME FOR HIGH-OUTPUT UNITS

Product	Run time
ELM2 LED HO (no remotes)	3.9 hours

* Meets Life Safety Code standard minimum illuminance of 0.1 FC and average illuminance of 1.0 FC. Assumes open space with no obstructions, mounting height: 7.5', ceiling height: 9', and reflectances: 80/50/20. Analysis based on independently tested photometrics.