

STIPULATION FOR REUSE  
THIS DRAWING IS PREPARED FOR  
USE ON A SPECIFIC SITE AT  
CONTINGENTLY WITH ITS ISSUE  
DATE. IT IS NOT TO BE REUSED  
FOR ANY OTHER PROJECT OR  
PROJECT SITE AT A LATER DATE  
OR FOR ANY OTHER PROJECT OR  
PROJECT SITE. THE USER OF THIS  
DRAWING IS RESPONSIBLE FOR  
OBTAINING ALL NECESSARY  
PERMITS AND APPROVALS FROM  
THE LOCAL AND STATE AGENCIES  
AND FOR ANY OTHER PROJECT OR  
PROJECT SITE. THE USER OF THIS  
DRAWING IS RESPONSIBLE FOR  
OBTAINING ALL NECESSARY  
PERMITS AND APPROVALS FROM  
THE LOCAL AND STATE AGENCIES  
AND FOR ANY OTHER PROJECT OR  
PROJECT SITE.



STORE NUMBER: 860  
I-59, EXIT 1  
NICHOLSON, MS 39463  
JOB NUMBER: 03-22-30003

ISSUE BLOCK



CHECKED BY: LST  
DRAWN BY: CRM  
DOCUMENT DATE: 02/06/23



2023.02.06 14:07:00-06'00'

FRAMING DETAILS

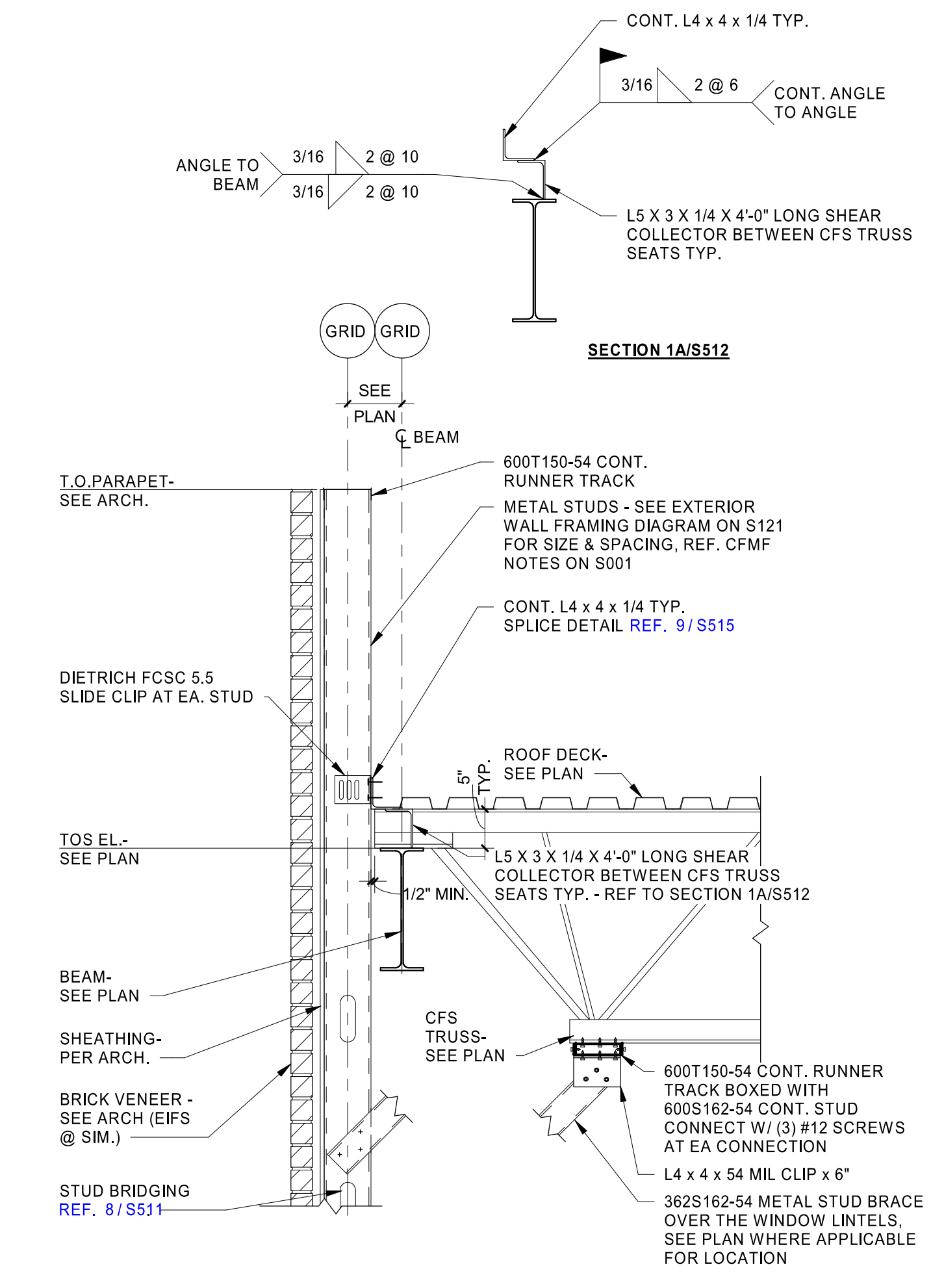
SHEET: S512



**1 SECTION**  
3/4" = 1'-0"

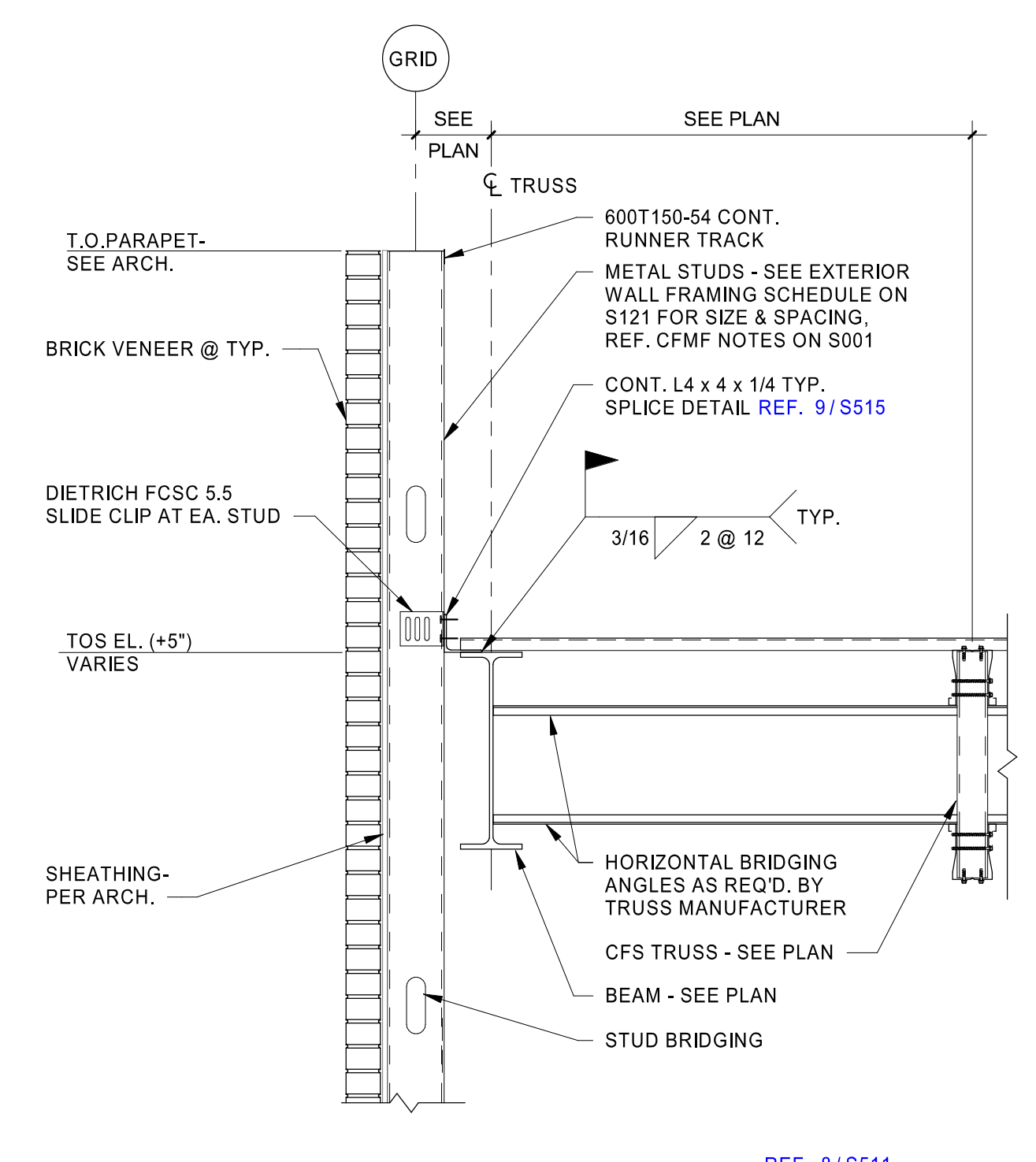

**2 SECTION**  
3/4" = 1'-0"

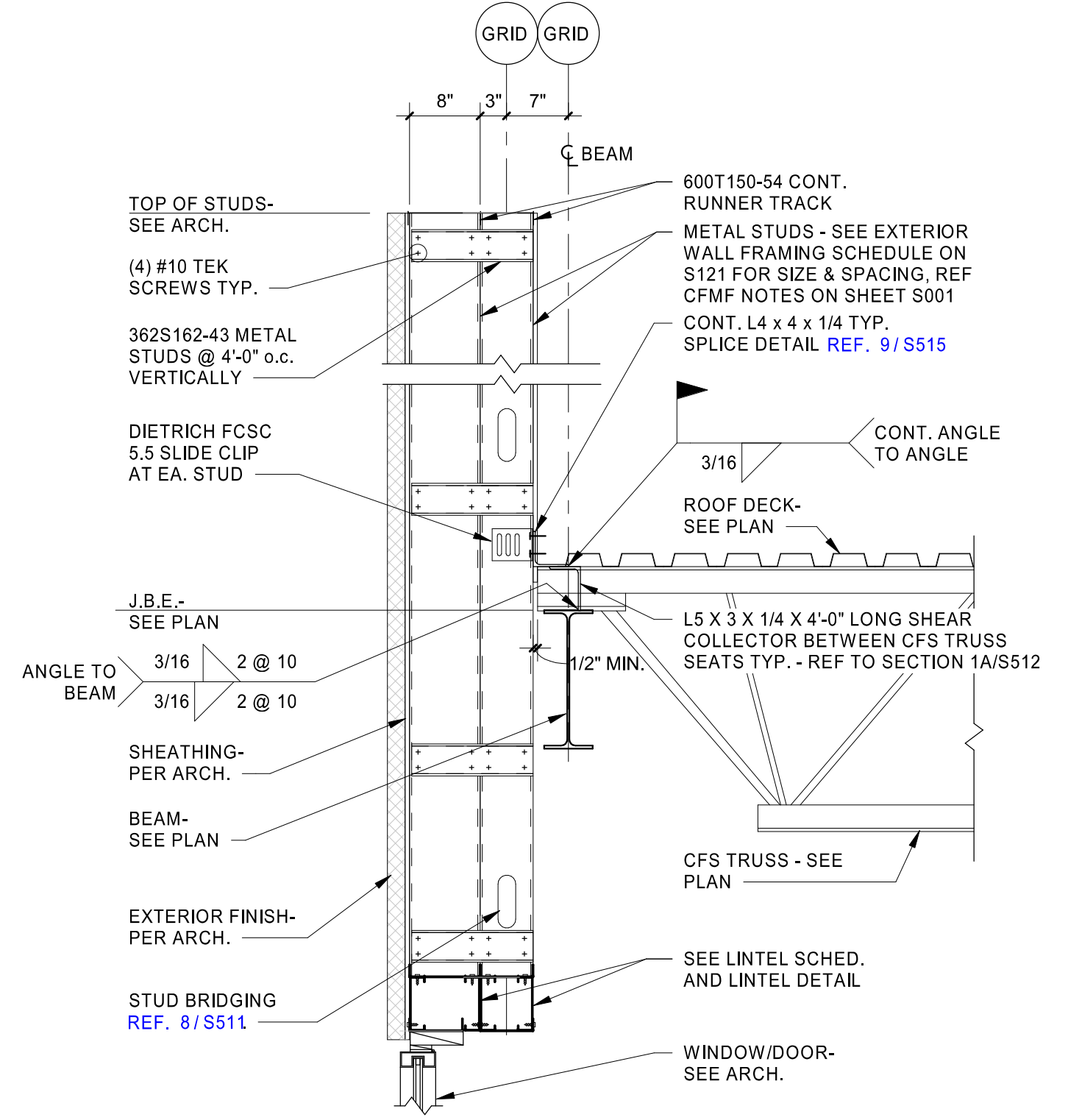

**3 SECTION**  
3/4" = 1'-0"

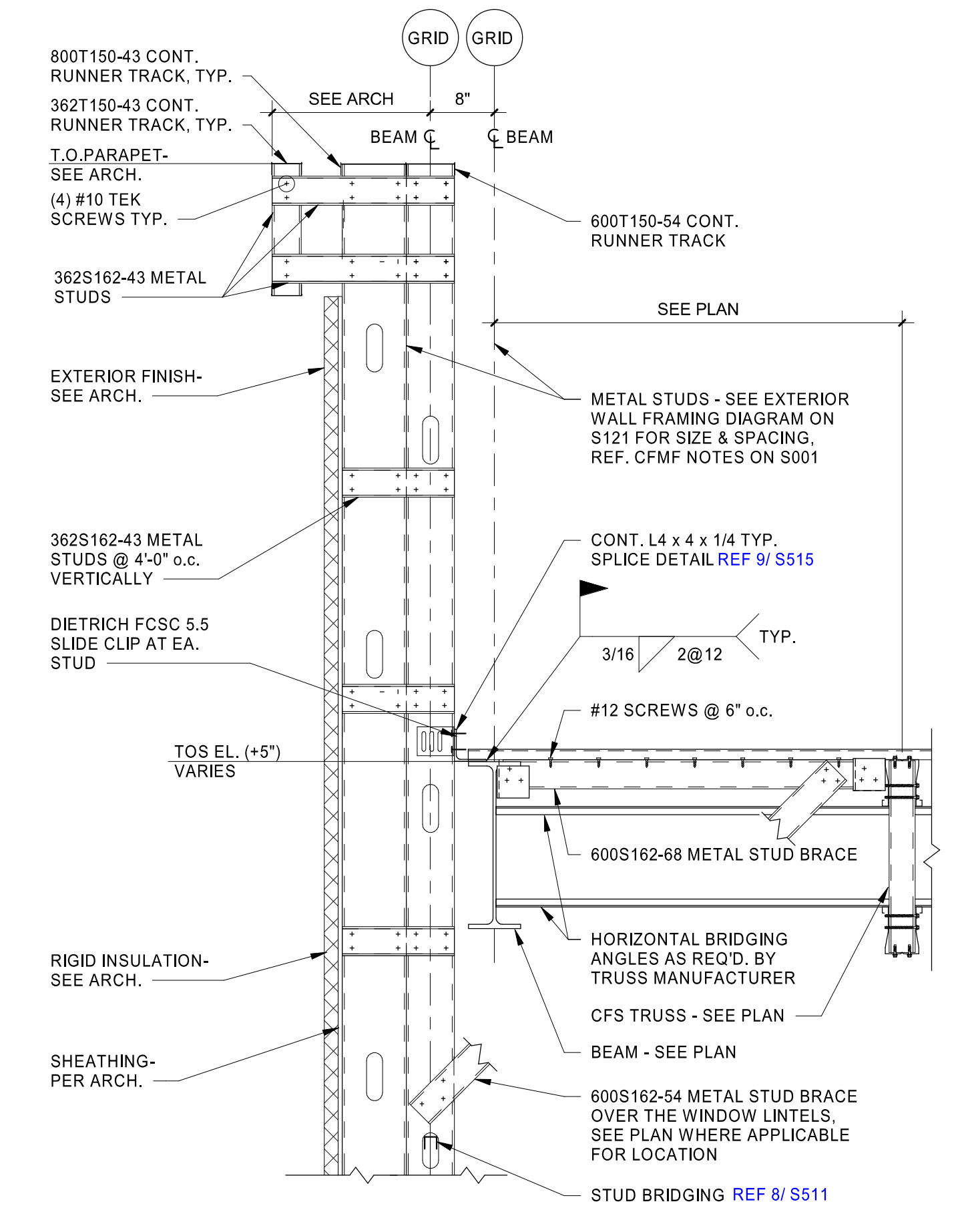

**4 SECTION**  
3/4" = 1'-0"

03/09/23 9:25:16 AM  
 C:\Users\lcrum\OneDrive\Documents\2023\Bentley\MS STR. 23\_001\_021\_HFA\_Crank\_May.rvt  
 23/03/23 9:25:16 AM