

---

# OWNER'S MANUAL

---

## FIXED AND ADJUSTABLE HEIGHT GANTRY CRANE 511/512 Series

1 Ton through 3 Ton Capacity

Product Code and Serial Number

### **WARNING**

This equipment should not be installed, operated or maintained by any person who has not read and understood all the contents of this manual. Failure to read and comply with the contents of this manual can result in serious bodily injury or death, and/or property damage.

**TIGER**  **TRACK**

## Table of Contents

Section	Page Number
1.0 Important Information and Warnings.....	3
1.1 Terms and Summary	
1.2 Warning Tags and Labels	
2.0 Technical Information.....	6
2.1 Specifications & Dimensions	
2.2 Crane Terms	
3.0 Pre-operational Procedures.....	10
3.1 Pre-Assembly	
3.2 Installation	
3.3 Swivel Lock Assembly	
3.4 Wheel Lock Assembly	
3.3 Tight Wire Assembly	
4.0 Operation.....	15
4.1 Introduction	
4.2 Shall's and Shall Not's for Operation	
4.4 Trolley Operation	
4.5 Hoist Operation	
5.0 Inspection.....	18
6.0 Lubrication.....	19
7.0 Troubleshooting.....	20
8.0 Warranty.....	21
9.0 Parts Information.....	23

## 1.0 Important Information and Warnings

### 1.1 Terms and Summary

This manual provides important information for personnel involved with the installation, operation and maintenance of this product. Although you may be familiar with this or similar equipment, it is strongly recommended that you read this manual before installing, operating or maintaining the product.

**Danger, Warning, Caution and Notice** - Throughout this manual there are steps and procedures that can present hazardous situations. The following signal words are used to identify the degree or level of hazard seriousness.

**▲ DANGER** Danger indicates an imminently hazardous situation which, if not avoided, **will** result in **death or serious injury**, and property damage.

**▲ WARNING** Warning indicates an imminently hazardous situation which, if not avoided, **could** result in **death or serious injury**, and property damage.

**▲ CAUTION** Caution indicates a potentially hazardous situation which, if not avoided, **may** result **minor or moderate injury** or property damage.

**NOTICE** Notice is used to notify people of installation, operation, or maintenance information which is important but not directly hazard-related.

### ▲ CAUTION

These general instructions deal with the normal installation, operation, and maintenance situations encountered with the equipment described herein. The instructions should not be interpreted to anticipate every possible contingency or to anticipate the final system, crane, or configuration that uses this equipment. For systems using the equipment covered by this manual, the supplier and owner of the system are responsible for the system's compliance with all applicable industry standards, and with all applicable federal, state and local regulations/codes.

This manual includes instructions and parts information for a variety of crane types. Therefore, all instructions and parts information may not apply to any one type or size of a specific crane. Disregard those portions of the instructions that do not apply.

Record your crane's Model and Serial Number (see Crane Drawing and **Section 9**) on the front cover of this manual for identification and future reference to avoid referring to the wrong manual for information or instructions on installation, operation, inspection, maintenance, or parts.

Use only Tiger Track authorized replacement parts in the service and maintenance of this crane.

## **WARNING**

Equipment described herein is not designed for and **MUST NOT** be used for lifting, supporting, or transporting people, or for lifting or supporting loads over people.

Equipment described herein should not be used in conjunction with other equipment unless necessary and/or required safety devices applicable to the system, crane, or application are installed by the system designer, system manufacturer, crane manufacturer, installer, or user.

Modifications to upgrade, rerate, or otherwise alter this equipment shall be authorized only by the original equipment manufacturer.

Cranes, used to handle hot molten material may require additional equipment or devices. Refer to ASTM E2349 "Standard Practice for Safety Requirements in Metal Casting Operations: Sand Preparation, Molding, and Core Making; Melting and Pouring; and Cleaning and Finishing".

Only trained and competent personnel should inspect and repair this equipment. Only competent erection personnel familiar with standard fabrication practices should be employed to assemble Tiger Track's cranes because of necessity in interpreting these instructions. Tiger Track is not responsible for quality of workmanship performed during crane installation.

Consult with a qualified structural engineer to determine if your support structure is adequate to support the loads generated by anchor bolt force, overturning moment, or axial load of your crane.

Crane cannot be utilized as an electrical or welding ground: a separate ground wire is required.

Overloading and improper use can result in injury.

Gantry crane should be used on a flat, level, smooth surface which is free of defects and obstructions.

Gantry Crane should not be moved with a load attached.

Gantry Crane should not be moved by pushing or pulling on load.

For Model 512 (Adjustable Height Gantry Crane), the I-beam height should be adjusted prior to attaching a load. DO NOT raise or lower the I-beam with a load attached. Make sure that the pin assemblies are immediately installed (including the cotter pins) after raising or lowering the crane to the desired height and before removing the overhead lifting device or lift truck. Do not operate or move crane without pins fully inserted (and secured with cotter pins) into both crane legs.

All welds must meet American Welding Society (AWS) specification D14.1 "Specification for Welding of Industrial and Mill Cranes and other Material Equipment."

Failure to read and comply with any one of the limitations noted herein can result in serious bodily injury or death, and/or property damage.

## **NOTICE**

It is the responsibility of the owner/user to install, inspect, test, maintain, and operate a crane in accordance with the applicable portions of OSHA Specification 1910.179 "Overhead and Gantry Cranes," ANSI B30.11, "Monorails and Underhung Cranes," and any other applicable standards.

It is the responsibility of the owner/user to have all personnel that will install, inspect, test, maintain, and operate a crane read the contents of this manual and applicable portions of OSHA Specification 1910.179 "Overhead and Gantry Cranes," ANSI B30.11, "Monorails and Underhung Cranes," and any other applicable standards.

If the crane owner/user requires additional information, or if any information in the manual is not clear, contact Tiger Track or the distributor of the crane. Do not install, inspect, test, maintain, or operate this crane unless this information is fully understood.

A regular schedule of inspection of the crane in accordance with the requirements of OSHA Specification 1910.179 "Overhead and Gantry Cranes," ANSI B30.11, "Monorails and Underhung Cranes," and any other applicable standards should be established and records maintained.

Dimensions and figures contained in this installation manual are for reference only and may differ for your particular application. Please refer to the Crane Drawing included with your crane.

### **1.2 Warning Tags and Labels**

This crane may be part of a lifting system including a hoist and trolley. It is the responsibility of the owner of such a lifting system to ensure that the lifting system be equipped with warning labels in accordance with applicable industry standards.

## 2.0 Technical Information

### 2.1 Specifications & Dimensions

#### 2.1.1 Product Code

**511 - 2000 - 10 - 10**

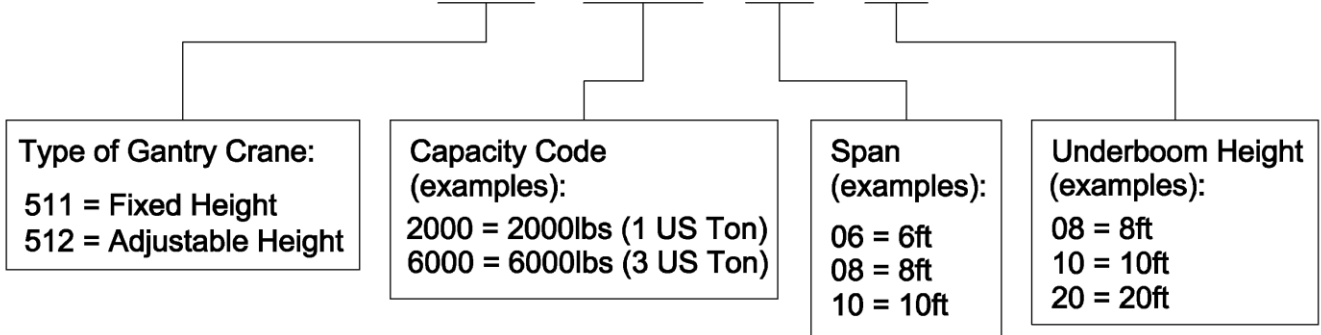

#### 2.1.2 Operating Conditions and Environment

Temperature range: -30°F to +150°F (-34°C to 66°C)

Relative Humidity: 85% or less

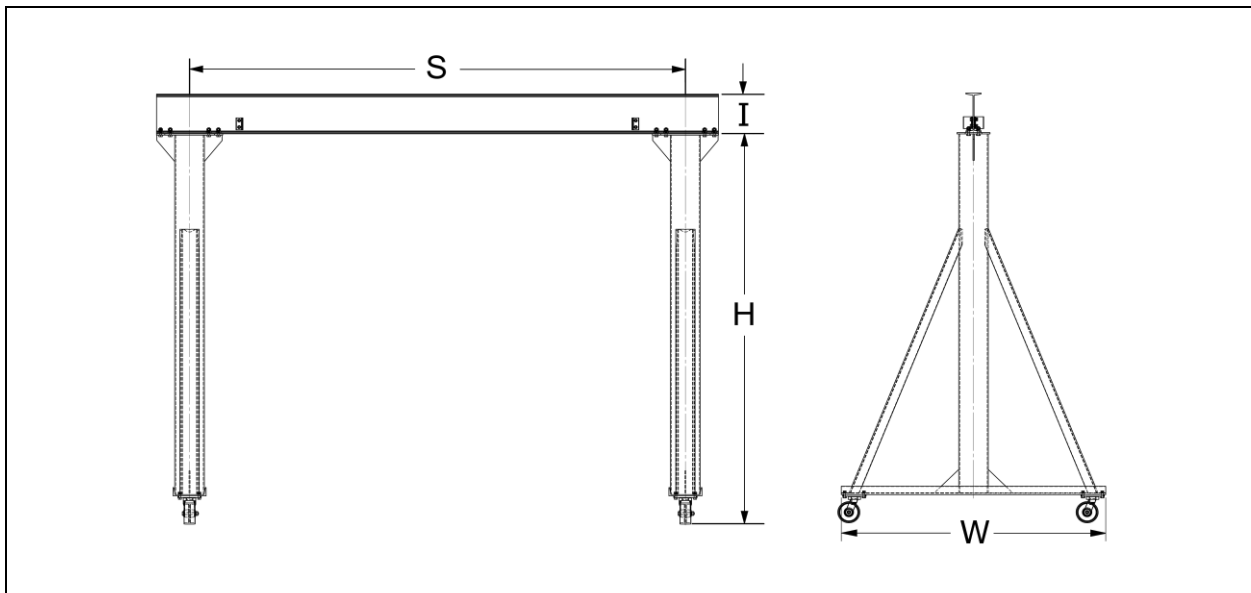
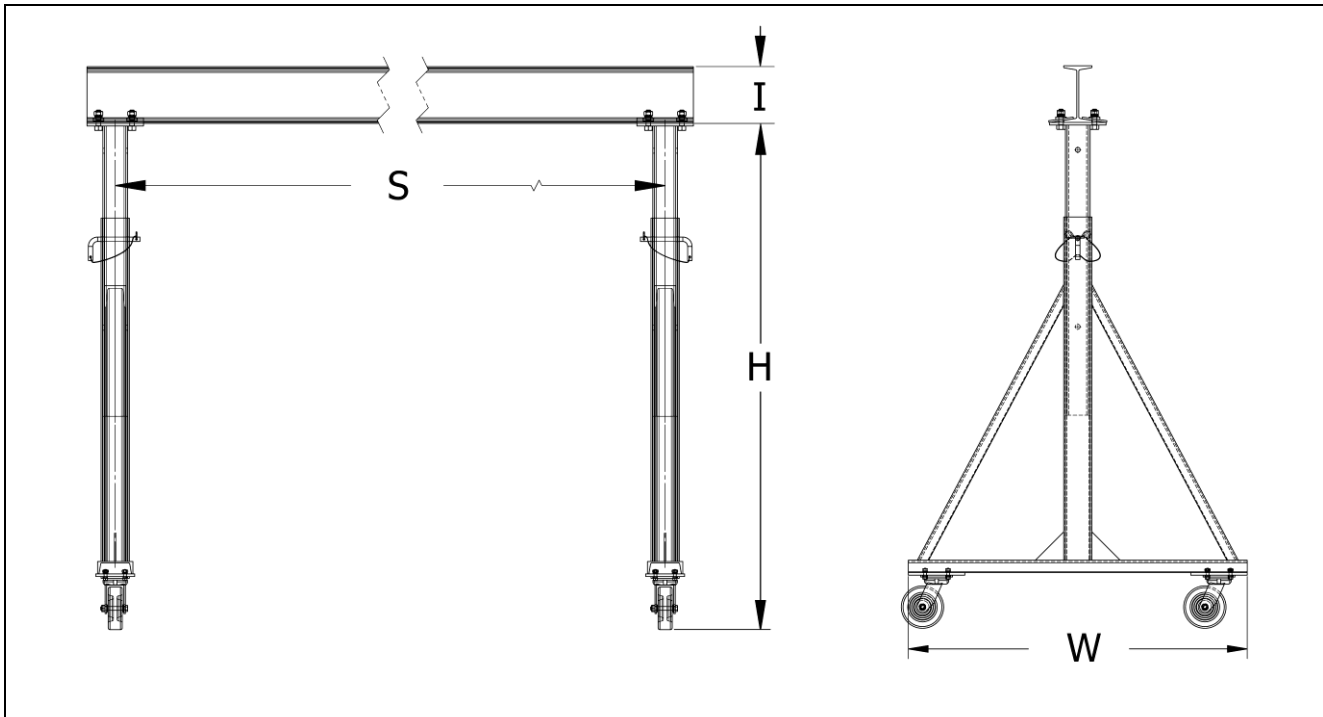

**Table 2-1 Model 511\* Specifications & Dimensions\* (Fixed Height Gantry)**

Capacity (US Ton)	Product Code	Span S (Feet-Inches)	Underboom Height H (Feet-Inches)	Base Width W (Feet-Inches)	Beam Size** (Inches)	Caster Size (Inches x Inches)	Weight (Lbs.)
1/2	511-1000-08-10	8'-0"	10'-0"	5'-6"	6"	2" x 6"	590
	511-1000-10-10	10'-0"	10'-0"	5'-6"	6"	2" x 6"	610
	511-1000-12-10	12'-0"	10'-0"	5'-6"	6"	2" x 6"	622
	511-1000-14-10	14'-0"	10'-0"	5'-6"	6"	2" x 6"	634
	511-1000-16-10	16'-0"	10'-0"	6'-6"	8"	2" x 6"	910
	511-1000-18-10	18'-0"	10'-0"	6'-6"	8"	2" x 6"	930
1	511-1000-20-10	20'-0"	10'-0"	6'-6"	8"	2" x 6"	950
	511-2000-08-10	8'-0"	10'-0"	5'-6"	8"	2" x 6"	665
	511-2000-10-10	10'-0"	10'-0"	5'-6"	8"	2" x 6"	685
	511-2000-12-10	12'-0"	10'-0"	5'-6"	8"	2" x 6"	710
	511-2000-14-10	14'-0"	10'-0"	5'-6"	8"	2" x 6"	720
	511-2000-16-10	16'-0"	10'-0"	6'-6"	8"	2" x 6"	740
2	511-2000-18-10	18'-0"	10'-0"	6'-6"	10"	2" x 6"	1020
	511-2000-20-10	20'-0"	10'-0"	6'-6"	10"	2" x 6"	1080
	511-4000-08-10	8'-0"	10'-0"	5'-6"	8"	3" x 8"	710
	511-4000-10-10	10'-0"	10'-0"	5'-6"	8"	3" x 8"	730
	511-4000-12-10	12'-0"	10'-0"	5'-6"	8"	3" x 8"	750
	511-4000-14-10	14'-0"	10'-0"	5'-6"	10"	3" x 8"	920
3	511-4000-16-10	16'-0"	10'-0"	6'-6"	10"	3" x 8"	970
	511-4000-18-10	18'-0"	10'-0"	6'-6"	10"	3" x 8"	1020
	511-4000-20-10	20'-0"	10'-0"	6'-6"	12"	3" x 8"	1275
	511-6000-08-10	8'-0"	10'-0"	5'-6"	10"	3" x 8"	1000
	511-6000-10-10	10'-0"	10'-0"	5'-6"	10"	3" x 8"	1050
	511-6000-12-10	12'-0"	10'-0"	5'-6"	10"	3" x 8"	1100
3	511-6000-14-10	14'-0"	10'-0"	5'-6"	10"	3" x 8"	1200
	511-6000-16-10	16'-0"	10'-0"	6'-6"	10"	3" x 8"	1250
	511-6000-18-10	18'-0"	10'-0"	6'-6"	12"	3" x 8"	1550
	511-6000-20-10	20'-0"	10'-0"	6'-6"	12"	3" x 8"	1610

\*Other spans, capacities, under boom height, etc. are available. Contact Customer Service

\*\*Listed Beam sizes are subject to change refer to the Crane Drawing for exact size



**Table 2-2 Model 512\* Specifications & Dimensions\* (Adjustable Height Gantry)**

Capacity (US Ton)	Product Code	Span S (Feet-Inches)		Underboom Height H (Feet-Inches)		Base Width W (Inches)	Beam Size** I (Inches)	Caster Size (Inches x Inches)	Weight (Lbs.)
		Min	Max	Min	Max				
1	512-2000-10-07	4'-0"	10'-0"	4'-4"	7'-0"	48"	8"	2" x 6"	560
	512-2000-10-09	4'-0"	10'-0"	5'-4"	9'-0"	60"	8"	2" x 6"	645
	512-2000-10-10	4'-0"	10'-0"	6'-5"	10'-0"	66"	8"	2" x 6"	680
	512-2000-10-12	4'-0"	10'-0"	7'-5"	12'-0"	78"	8"	2" x 6"	785
	512-2000-10-14	4'-0"	10'-0"	8'-5"	14'-0"	90"	8"	2" x 6"	855
2	512-4000-10-07	6'-0"	10'-0"	4'-4"	7'-0"	48"	8"	3" x 8"	605
	512-4000-10-09	6'-0"	10'-0"	5'-4"	9'-0"	60"	8"	3" x 8"	715
	512-4000-10-10	6'-0"	10'-0"	5'-10"	10'-0"	66"	8"	3" x 8"	750
	512-4000-10-12	6'-0"	10'-0"	7'-9"	12'-0"	78"	8"	3" x 8"	830
	512-4000-10-14	6'-0"	10'-0"	8'-9"	14'-0"	90"	8"	3" x 8"	905
3	512-6000-10-07	6'-0"	10'-0"	4'-4"	7'-0"	48"	10"	3" x 8"	1225
	512-6000-10-09	6'-0"	10'-0"	5'-4"	9'-0"	60"	10"	3" x 8"	1239
	512-6000-10-10	6'-0"	10'-0"	6'-11"	10'-0"	66"	10"	3" x 8"	1270
	512-6000-10-12	6'-0"	10'-0"	7'-11"	12'-0"	78"	10"	3" x 8"	1400
	512-6000-10-14	6'-0"	10'-0"	8'-11"	14'-0"	90"	10"	3" x 8"	1515

\*Other spans, capacities, under boom height, etc. are available. Contact Customer Service

\*\*Listed Beam sizes are subject to change refer to the Crane Drawing for exact size

## 2.2 Crane Terms

In order to better understand jib/gantry cranes, here are the commonly used terms that are used to specify and design jibs/gantries:

- **Anchor Bolts:** Large steel bolts used to mount a base mounted pillar jib crane to the Tiger Track recommended foundation.
- **Boom:** The horizontal beam on which the hoist trolley travels.
- **Fitting Centers:** The distance, centerline to centerline, between two support brackets (fittings) of a wall mounted jib crane.
- **Capacity:** The maximum live weight that the crane is designed to support.
- **End Stops:** Bolted to each end of the boom to prevent the trolley from falling off of the beam.
- **Foundation:** For free standing pillar base mounted jibs. Foundations are used to support the jib and prevent it from tipping over.
- **Gussets:** Reinforcing plates used to stiffen mast at the base plate.
- **Head:** Houses the roller, and lowers the crushing forces that are imposed on the mast.
- **Height Under the Boom (H.U.B.):** The distance from the finished floor to the underside of the crane boom. To find the underboom, take the height of the load, plus the distance the load is lifted, plus the headroom requirements of the hoist/trolley and any attachments. ( Extra room in addition to the minimum required H.U.B. may be helpful for crane operations.)
- **Mast:** The vertical member of the jib, which supports the crane. Pillar jibs have round pipes as masts.
- **Overall Height:** The highest point of the jib crane (including any hardware). A minimum clearance (usually 3") is required from any overhead obstruction.
- **Hoist:** The actual lifting mechanism (powered by electric, air, or manual movement) that hangs from the trolley that rides on the boom of a jib crane.
- **Trolley:** The mechanism that travels back and forth on the crane boom (powered by electric, air, or manual movement) which the hoist hangs from.
- **Overtipping Moment:** The force applied to the mounting structure of a self-supporting pillar jib. This force is caused by suspending a load from the boom, and is at maximum with full load at the end of the boom.
- **Rotation Stops:** Limits the rotation of a pillar base mounted jib crane boom (which are standard at 360°). Stops are field welded to the mast.
- **Span:** The span for a pillar base mounted jib crane is the distance from the center of the mast to the end of the boom. The span for a column mounted crane is measured from the face of the mounting surface to the end of the boom. The span for a mast type jib crane is measured from the center of the vertical mast to the end of the boom.
- **Thrust and Pull:** Thrust and Pull are forces applied to a wall/column mounted jib cranes support structure. Thrust is the pushing force exerted on the structure, and pull is the tensile, or pulling force. Thrust and Pull are equal to each other (but opposite in direction), and are given at maximum with full load at the end of the boom.
- **Clear Span:** The measurement between the end stops on a crane boom.
- **Hook Travel:** The distance that the hook on the hoist travels.

## 3.0 Preoperational Procedures

### 3.1 Pre-Assembly

- 3.1.1 Check crane for physical damage due to shipping.
- 3.1.2 Prior to assembly make sure all capacity stickers and warning labels are clearly visible and properly affixed.
- 3.1.3 Check packing list to ensure no parts have been lost prior to initiating assembly of crane.
- 3.1.4 See Crane Drawing for bolt locations and dimensions.
- 3.1.5 Read entire manual before installing the crane.
- 3.1.6 **⚠ WARNING** Do not assemble/dissassemble without proper lifting equipment.
- 3.1.7 Identify crane model (511 = fixed height, 512 = adjustable height). Reference **Table 2-1** and **Table 2-2**. Find the applicable assembly instructions in **Section 3.2** based on your crane model type.
- 3.1.8 **⚠ CAUTION** Figures are for reference only and may differ for your particular application. Reference Crane Drawing included with crane information packet for specific information.

### 3.2 Installation

**⚠ WARNING** If multiple cranes were ordered, locate stamped serial number on each crane part for proper part matching during installation. Although crane parts may appear to be identical, each crane is assembled and built separately. All parts that do not have the same stamped serial number may not line up properly for installation.

#### 3.2.1 For Model 511 (Fixed Height Gantry):

- 3.2.1.1 Reference **Figure 3-1** for general assembly layout.
- 3.2.1.2 Bolt two (2) CASTER WHEELS to each LEG ASSEMBLY using BOLTS, LOCKWASHERS, AND NUTS provided and make sure that all fasteners are securely tightened (see **Figure 3-2**). If applicable, attach optional swivel locks or wheel locks (see **Section 3.3** and **Section 3.4**, respectively).
- 3.2.1.3 Secure span BEAM to the top of each LEG ASSEMBLY with the provided BOLTS, NUTS, LOCK WASHERS, and (if applicable) BEVELED WASHERS (see **Figure 3-3**).
- 3.2.1.4 **⚠ WARNING** Do not operate or move crane without all fasteners and hardware in place and properly secured. See **Table 3-1** for torque specifications.
- 3.2.1.5 Install END STOPS onto BEAM using the hardware provided.
- 3.2.1.6 For units with Tight Wire Kit, refer to **Section 3.4**.

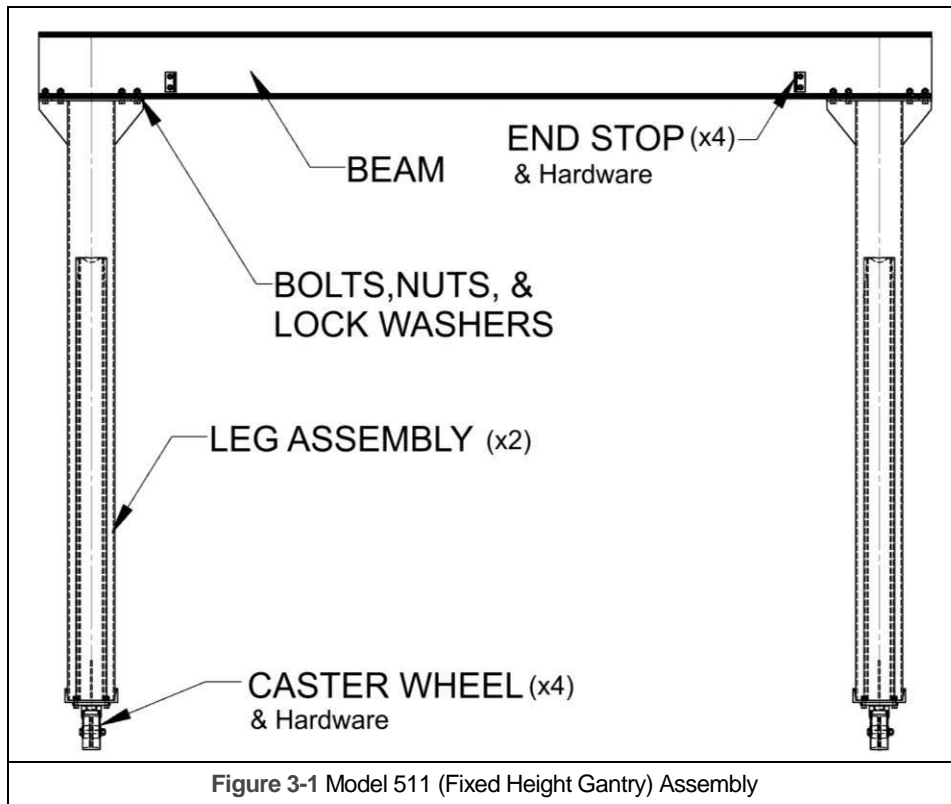
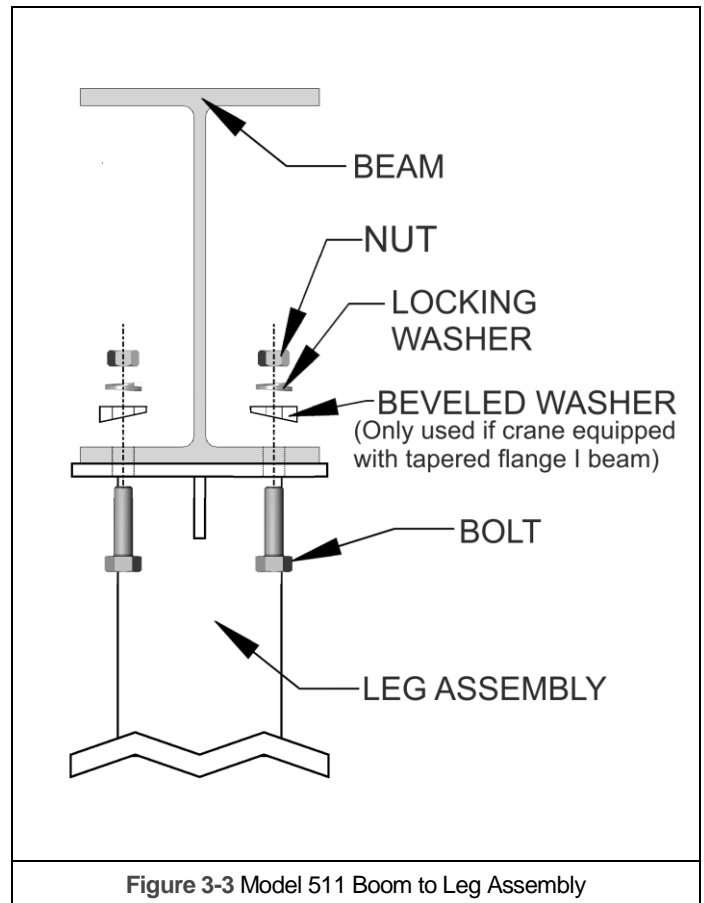
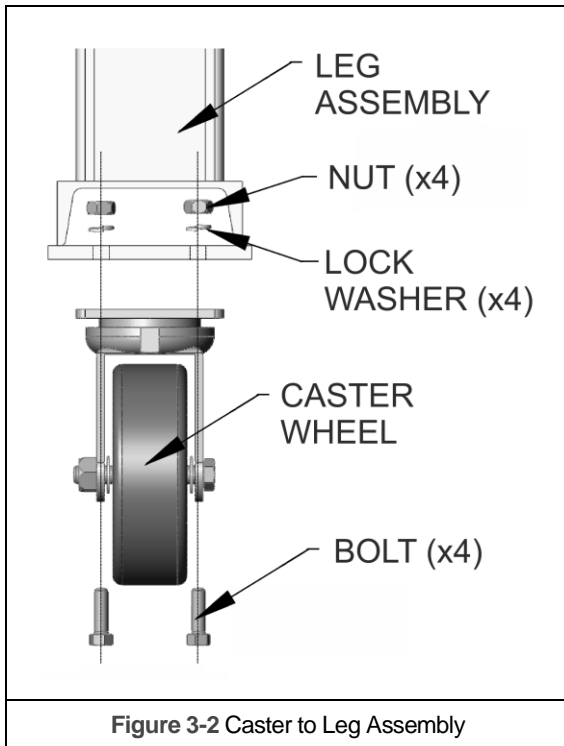
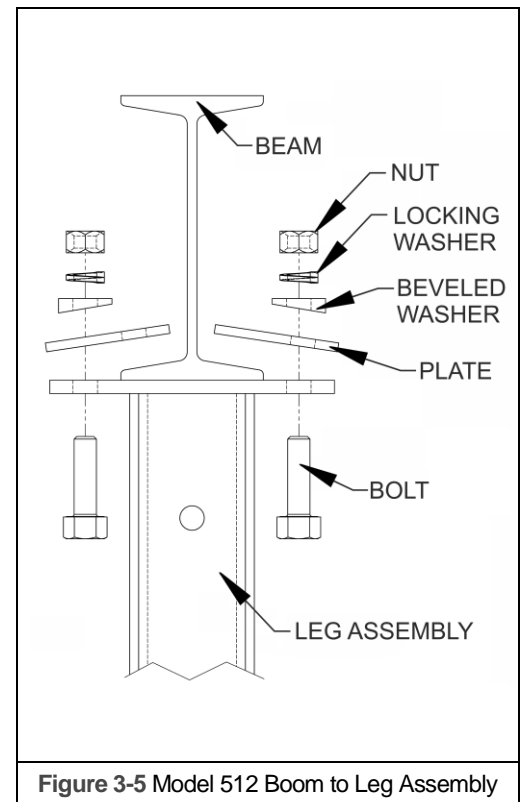
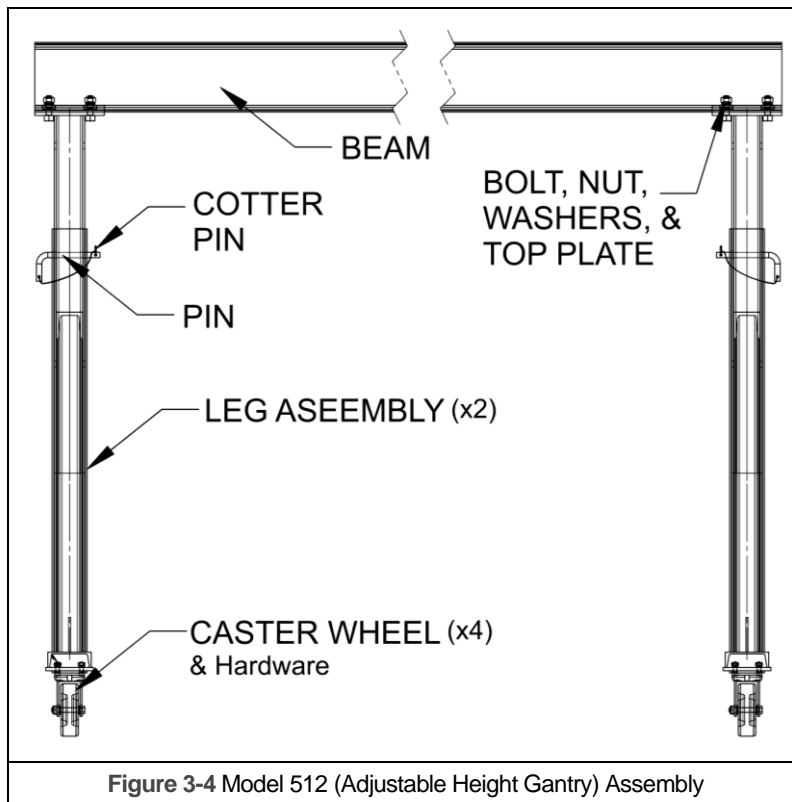

Table 3-1 Torque Specifications	
Bolt Dia.	Torque (ft.-lbs.)
1/4" - 20	6
3/8" - 16	20
1/2" - 13	50
5/8" - 11	95
3/4"-10	175
7/8" - 9	300



### 3.2.2 For Model 512 (Adjustable Height Gantry):

- 3.2.2.1 Reference **Figure 3-4** general assembly layout.
- 3.2.2.2 Bolt two (2) CASTER WHEELS to each LEG ASSEMBLY using BOLTS, LOCKWASHERS, AND NUTS provided and make sure that all fasteners are securely tightened (see **Figure 3-2**). If applicable, attach optional swivel locks or wheel locks (see **Section 3.3** and **Section 3.4**, respectively).
- 3.2.2.3 Secure BEAM for fastening to LEG ASSEMBLY. Loosen BOLTS on leg assembly TOP PLATE. Slide BEAM under PLATES on both sides of LEG ASSEMBLY. Once complete, be sure to tighten all bolts securely. Repeat step for attaching other LEG ASSEMBLY to other end of BEAM (See **Figure 3-5**).
- 3.2.2.4 To obtain desired height, remove PINS (shipped in place at bottom hole position) and lift to desired height. Reinstall PIN and COTTER PIN securely.
- 3.2.2.5 **⚠ WARNING** Do not operate or move crane without all pins, fasteners and hardware in place and properly secured. See **Table 3-1** for torque specifications.
- 3.2.2.6 If applicable, install END STOPS onto BEAM (see **Figure 3-1** for End Stops).
- 3.2.2.7 For units with Tight Wire Kit, refer to **Section 3.3**.



### 3.3 Swivel Lock Assembly

- 3.3.1 Refer to **Figure 3-6**.
- 3.3.2 Attach the SWIVEL LOCK to each caster wheel using the BOLTS, LOCKWASHERS, and NUTS provided.
- 3.3.3 Pull on the PIN RING and rotate the WHEEL to the desired PIN HOLE position.
- 3.3.4 Release the PIN RING so that the LOCKING PIN goes into the desired PIN HOLE.
- 3.3.5 Ensure that the LOCKING PIN is in engaged in the PIN HOLE.

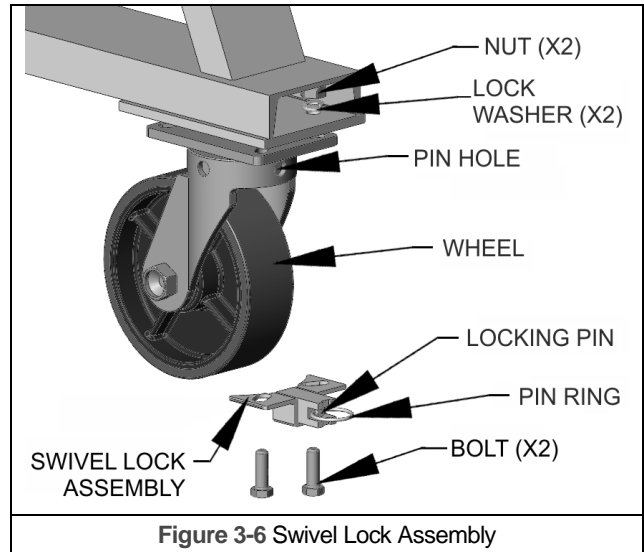

Figure 3-6 Swivel Lock Assembly

### 3.4 Wheel Lock Assembly

- 3.4.1 Refer to **Figure 3-7**
- 3.4.2 Center SPANNER into WHEEL ASSEMBLY.
- 3.4.3 Place BRAKE SHOE over SPANNER and WASHER 1.
- 3.4.4 Position WHEEL between LEGS and insert BOLT through one side of CASTER to opposite side.
- 3.4.5 Position WASHER 2 over protruding thread at the end of BOLT.
- 3.4.6 Position BRAKE LEVER over BOLT and against WASHER 2.
- 3.4.7 Position WASHER 3 and LOCK NUT over BOLT.
- 3.4.8 With BRAKE LEVEL in horizontal position, tighten LOCK NUT until wheel rotation is impeded.
- 3.4.9 Rotate LOCK NUT counter clockwise by  $\frac{1}{4}$  turn increments until the WHEEL rotates freely with the BRAKE LEVEL in a horizontal position.
- 3.4.10 Ensure proper operation. WHEEL must turn freely with BRAKE LEVER in "off" position (horizontal). WHEEL must be locked with BRAKE LEVER in "on" position (rotated from horizontal).

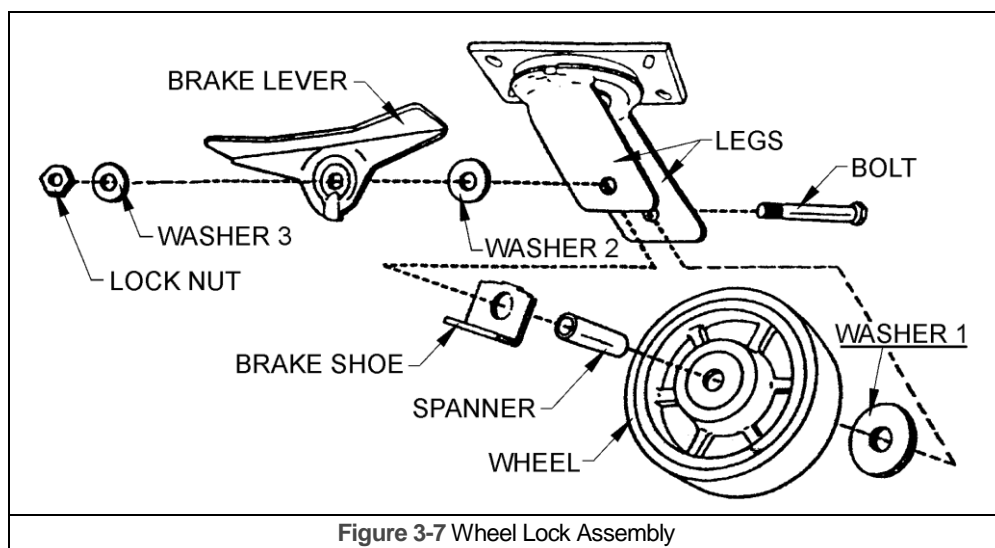
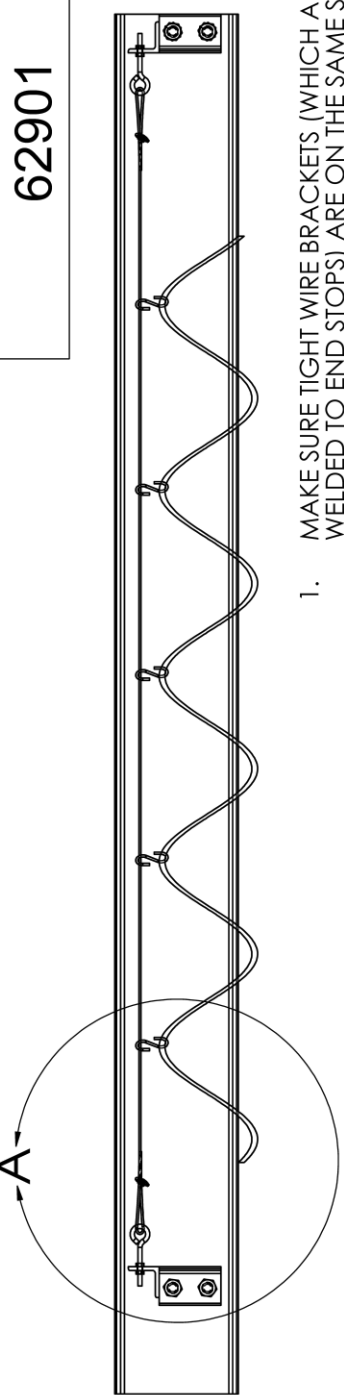
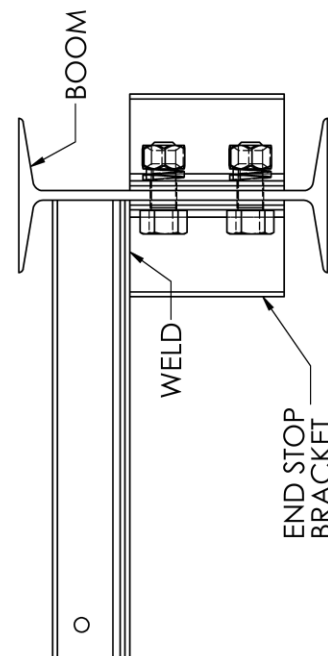

Figure 3-7 Wheel Lock Assembly

### 3.5 Tight Wire Assembly

62901





1. MAKE SURE TIGHT WIRE BRACKETS (WHICH ARE WELDED TO END STOPS) ARE ON THE SAME SIDE OF BOOM.
2. LOOP CABLE THROUGH EYE BOLT AT ONE END. TIGHTEN WITH CABLE CLAMP. PUT "S" HOOKS ON CABLE. LOOP CABLE THROUGH OTHER EYE BOLT. TIGHTEN WITH CABLE CLAMP.
3. SLIP EYE BOLT THROUGH TIGHT WIRE BRACKET AND TIGHTEN EYE BOLT UNTIL TIGHT WIRE IS TIGHT.
4. \*\*NOTE: FOR CRANES WITH 6" BEAM TIGHT WIRE BRACKET MAY HAVE DIFFERENT ORIENTATION DUE TO SPACE CONSTRAINTS.

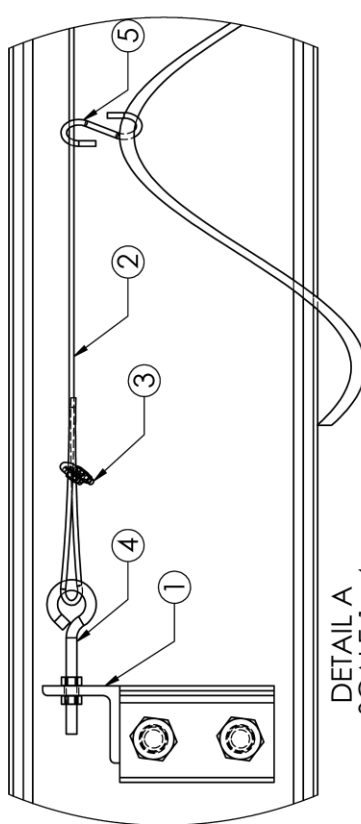

**DETAIL A**  
**SCALE 1 : 4**

ITEM NO.	DESCRIPTION	QTY.
1	TIGHT WIRE ANGLES (WELDED TO ES)	2
2	1/8" DIA CABLE (LENGTH = CRANE SPAN)	1
3	CABLE CLAMPS	2
4	5/16" EYE BOLTS W/ NUTS	2
5	"S" HOOKS	#



**TIGER TRACK**

DESCRIPTION		TIGHT WIRE ASSEMBLY	
PART NUMBER	62901	MATERIAL	
DRAWN BY	D. Grujic	DATE DRAWN	05/02/07
		DRAWING SIZE	A
		SHEET NUMBER	1
		SCALE	1:10

**TOLERANCES:** DECIMALS (UNLESS OTHERWISE SPECIFIED) TWO PLACE (00) ± .015 THREE (000) ± .005 ANGLES ± 30 MINUTES ALL DIMENSIONS ARE IN INCHES UNLESS OTHERWISE SPECIFIED.

PROPRIETARY AND CONFIDENTIAL: THE INFORMATION CONTAINED IN THIS DRAWING IS THE SOLE PROPERTY OF TIGER TRACK ANY REPRODUCTION IN PART OR AS A WHOLE WITHOUT THE WRITTEN PERMISSION OF TIGER TRACK IS PROHIBITED.

## 4.0 Operation

### 4.1 Introduction

The suggestions below are not intended to take precedence over existing plant safety rules and regulations or OSHA regulations. It is the responsibility of the owner to make personnel aware of all federal, state and local rules and codes, and to make certain operators are properly trained.

#### **DANGER**

DO **NOT** WALK UNDER A SUSPENDED LOAD

#### **WARNING**

CRANE OPERATORS SHALL BE REQUIRED TO READ THE OPERATION SECTION OF THIS MANUAL, THE WARNINGS CONTAINED IN THIS MANUAL, INSTRUCTION AND WARNING LABELS ON THE CRANE OR LIFTING SYSTEM, APPLICABLE ANSI AND OSHA SAFETY STANDARDS, AND THE CRANE OPERATOR'S MANUAL PUBLISHED BY THE CRANE MANUFACTURER'S ASSOCIATION OF AMERICA (CMAA). THE OPERATOR SHALL ALSO BE REQUIRED TO BE FAMILIAR WITH THE CRANE AND CRANE CONTROLS BEFORE BEING AUTHORIZED TO OPERATE THE CRANE OR LIFTING SYSTEM.

CRANE OPERATORS SHOULD BE TRAINED IN PROPER RIGGING PROCEDURES FOR THE ATTACHMENT OF LOADS TO THE HOIST HOOK.

CRANE OPERATORS SHOULD BE TRAINED TO BE AWARE OF POTENTIAL MALFUNCTIONS OF THE EQUIPMENT THAT REQUIRE ADJUSTMENT OR REPAIR, AND TO BE INSTRUCTED TO STOP OPERATION IF SUCH MALFUNCTIONS OCCUR, AND TO IMMEDIATELY ADVISE THEIR SUPERVISOR SO CORRECTIVE ACTION CAN BE TAKEN.

CRANE OPERATORS SHOULD HAVE NORMAL DEPTH PERCEPTION, FIELD OF VISION, REACTION TIME, MANUAL DEXTERITY, HEARING, AND COORDINATION.

CRANE OPERATORS SHOULD **NOT** HAVE A HISTORY OF OR BE PRONE TO SEIZURES, LOSS OF PHYSICAL CONTROL, PHYSICAL DEFECTS, OR EMOTIONAL INSTABILITY THAT COULD RESULT IN ACTIONS OF THE OPERATOR BEING A HAZARD TO THE OPERATOR OR TO OTHERS.

CRANE OPERATORS SHOULD **NOT** OPERATE A CRANE OR LIFTING SYSTEM WHEN UNDER THE INFLUENCE OF ALCOHOL, DRUGS, OR MEDICATION.

#### **NOTICE**

- Read OSHA Specification 1910.179 "Overhead and Gantry Cranes," ANSI B30.11, "Monorails and Underhung Cranes," and any other applicable standards.
- Read the hoist manufacturer's Operating and Maintenance Instructions.
- Read all labels attached to equipment.

## 4.2 Shall's and Shall Not's for Operation

### **WARNING**

Improper operation of a crane can create a potentially hazardous situation which, if not avoided, could result in death or serious injury, and substantial property damage. To avoid such a potentially hazardous situation **THE OPERATOR SHALL:**

- **NOT** operate a damaged, malfunctioning or unusually performing crane.
- **NOT** operate a crane until you have thoroughly read and understood Manufacturer's Operating and Maintenance Instructions or Manuals.
- Be familiar with operating controls, procedures, and warnings.
- **NOT** operate a crane that has been modified without the manufacturer's approval.
- **NOT** lift more than rated load for the crane/hoist/trolley.
- **NOT** use the crane to lift, support, or transport people.
- **NOT** lift loads over people.
- **NOT** operate a crane unless all persons are and remain clear of the supported load.
- **NOT** operate unless load is centered under hoist.
- **NOT** leave load supported by the crane/hoist unattended unless specific precautions have been taken.
- **NOT** allow the crane to be used as an electrical or welding ground.
- **NOT** remove or obscure the warnings on the crane.
- **NOT** operate a crane on which the safety placards or decals are missing or illegible.
- **NOT** operate a crane that has any changes in rolling effort or unusual noises.
- Warn personnel before lifting or moving a load.
- Warn personnel of an approaching load.
- Ensure that endstops are in place.
- Ensure that all bolts are tight and have lockwashers.
- **NOT** put hands near moving parts.
- **NOT** move or operate a crane without pins fully inserted into both crane legs.
- **NOT** move crane with load attached.
- **NOT** adjust crane height with load attached.
- Move crane on a flat, level, smooth surface.

### **CAUTION**

Improper operation of a crane can create a potentially hazardous situation which, if not avoided, could result in minor or moderate injury, or property damage. To avoid such a potentially hazardous situation **THE OPERATOR SHALL:**

- Maintain a firm footing or be otherwise secured when operating the crane.
- Make sure the load is free to move and will clear all obstructions.
- Avoid swinging the load or hook.
- Inspect the crane regularly, replace damaged or worn parts, and keep appropriate records of maintenance.
- Use the crane manufacturer's recommended parts when repairing the unit.
- Lubricate the roller bearings per crane manufacturer's recommendations.
- **NOT** allow your attention to be diverted from operating the crane.
- **NOT** allow the crane to be subjected to sharp contact with other structures, or objects through misuse.
- **NOT** adjust or repair the crane unless qualified to perform such adjustments or repairs.
- Ensure that festooning cannot be snagged or pinched.

### **4.3 Handling the Trolley Motion**

Refer to the trolley's operating instructions.

### **4.4 Handling the Hoist Motion**

Refer to the hoist's operating instructions.

## 5.0 Inspection

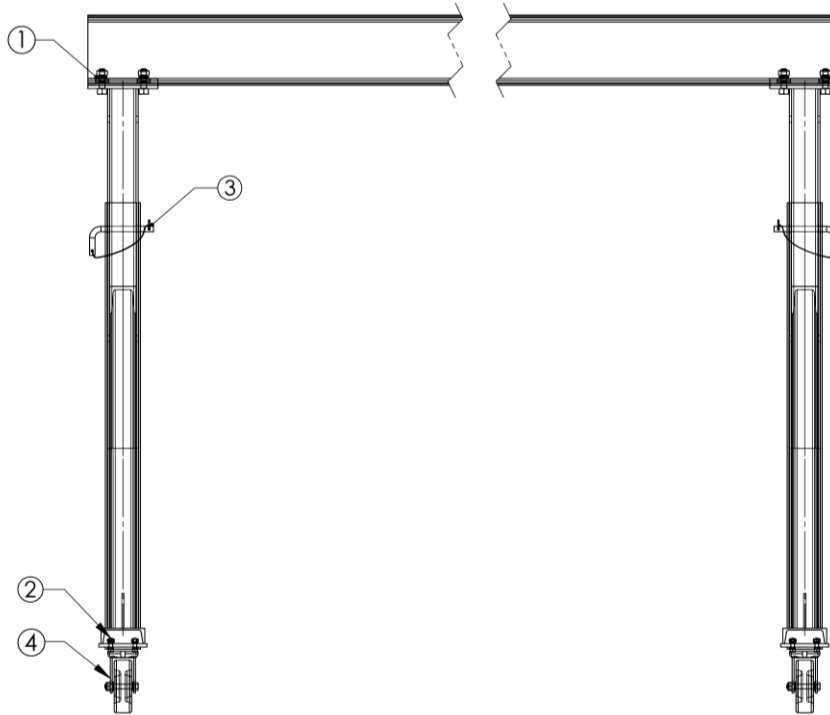

**Table 5-3 Crane Inspection**

Figure No.	Item	Inspection	Frequency
1	Top Plate Hardware	Check that the lock-washers are fully compressed and the nuts are tightened to manufacturer's specifications ( <b>Table 3-1</b> ).	Before and After Each Use
2	Caster Hardware	Check that the lock-washers are fully compressed and the nuts are tightened to manufacturer's specifications ( <b>Table 3-1</b> ).	Before and After Each Use
3	Locating Pins and Cotter Pins	Make sure locating pins and cotter pins are securely in place.	Before and After Each Use
4	Castors	Keep casters lubricated through zirk fittings. Check for cracks, grooves, pitting, or excessive wear. Wheels should be replaced if these conditions exist.	Every 1000 hours Or 6 months
5	End Stop/ Tight Wire Kit	Check that the lock-washers are fully compressed and the nuts are tightened the proper torque specifications ( <b>Table 3-1</b> ).	Every 500 hours Or 3 months
-	Additional Items	Conduct a general inspection of all additional items you may have purchased.	Every 1000 hours Or 6 months
-	General	Conduct a visual inspection of the crane overall and speak with the crane operator about the crane's performance, if any flaws are noticed take crane out of service and report to manufacturer immediately.	Every 1000 hours Or 6 months

### **▲WARNING**

Any changes in rolling effort or unusual noises must be immediately identified and corrected.

## **6.0 Lubrication**

- 6.1 The most economical way to maintain a jib/gantry crane and keep it in good operating condition is to lubricate all moving parts regularly.
- 6.2 Regular inspection of all parts should be made and all loose parts should be adjusted. Parts that become worn should be replaced at once.
- 6.3 The interval of lubrication varies as to the use of the machine. A crane operating 24 hours a day, 7 days a week, should demand lubrication once a week. Whereas a standard duty crane, operating eight hours a day on a five day week should be lubricated once every two to three weeks. Cranes under a standby classification, being used once or twice a month, should be lubricated at least once every six months.
- 6.4 The actual interval from one lubrication to the next depends entirely upon the type and length of operation to which the crane is subjected. These factors are variable and sometimes cannot be definitely determined. In this case, the crane operator or maintenance engineer would determine when the crane should be lubricated.
- 6.5 The casters on the gantry crane require lubrication. Grease fittings are provided.
- 6.6 Grease for casters should comply with NLGI No. 1 or No. 2.
- 6.7 If Texaco products are not available, equivalent lubricants are satisfactory.

## 7.0 Troubleshooting

Table 7-1 Troubleshooting Guide

Symptom	Cause	Remedy
Crane does not move smoothly	Casters are worn or damaged	Replace casters
	Casters need grease	Grease casters
	There is an obstruction at wheel(s)	Remove obstruction

## **8.0 Warranty**

All products sold by Harrington Hoists, Inc. are warranted to be free from defects in material and workmanship from date of shipment by Harrington for the following periods:

- Manual Hoists, Trolleys, Beam Clamps – 2 years**
- Tiger Track Jibs & Gantries – Manual – 5 years, Powered – 1 year**
- NER2/ER2 Hoists Enhanced Features Models – 3 Years**
- (N)ER030L(D), All Other Electric and Air Hoists, Trolleys, Crane Components – 1 year**
- Sling Chain, Spare / Replacement Parts – 1 year**
- NER2/ER2 “The Guardian” Smart Brake – 10 years**

The product must be used in accordance with manufacturer’s recommendations and must not have been subject to abuse, lack of maintenance, misuse, negligence, or unauthorized repairs or alterations.

Should any defect in material or workmanship occur during the above time period in any product, as determined by Harrington Hoist’s inspection of the product, Harrington Hoists, Inc. agrees, at its discretion, either to replace (not including installation) or repair the part or product free of charge and deliver said item F.O.B. Harrington Hoists, Inc. place of business to customer.

Customer must obtain a Return Goods Authorization as directed by Harrington or Harrington’s published repair center prior to shipping product for warranty evaluation. An explanation of the complaint must accompany the product. Product must be returned freight prepaid. Upon repair, the product will be covered for the remainder of the original warranty period. Replacement parts installed after the original warranty period will only be eligible for replacement (not including installation) for a period of one year from the installation date. If it is determined there is no defect, or that the defect resulted from causes not within the scope of Harrington’s warranty, the customer will be responsible for the costs of returning the product.

Harrington Hoists, Inc. disclaims any and all other warranties of any kind expressed or implied as to the product’s merchantability or fitness for a particular application. Harrington will not be liable for death, injuries to persons or property or for incidental, contingent, special or consequential damages, loss or expense arising in connection with the use or inability whatever, regardless of whether damage, loss or expense results from any act or failure to act by Harrington, whether negligent or willful, or from any other reason.

**This Page Intentionally Left Blank**

## 9.0 Parts Information

When ordering Parts, please provide the crane serial number which is stamped into each crane part (see **Figure 9-0**). The serial number is also located underneath the “Tiger Track” logo.

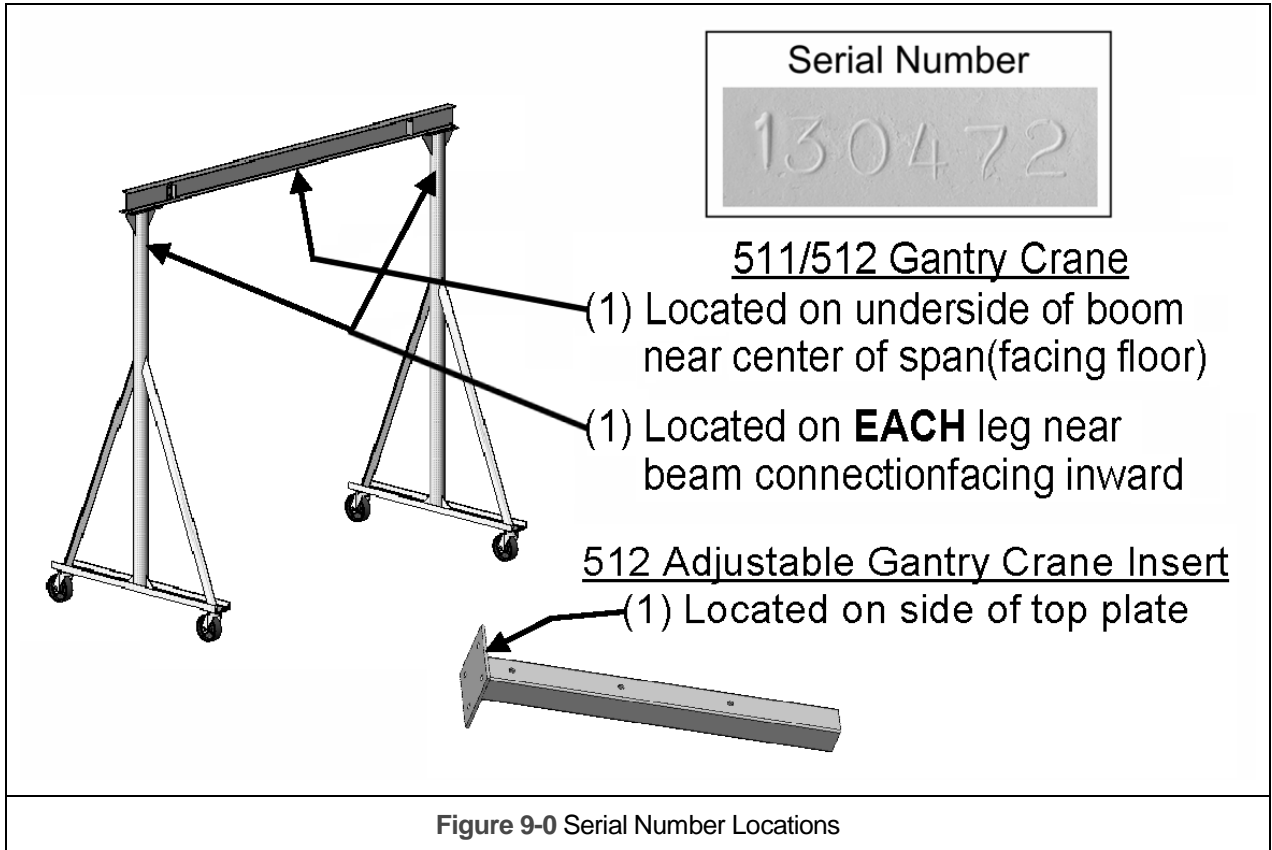

The parts list is arranged into the following sections:

Section	Page
9.1 Model 511 Crane Parts.....	22
9.2 Model 512 Crane Parts.....	24
9.3 Labels.....	26

9.1 Model 511 Crane Parts

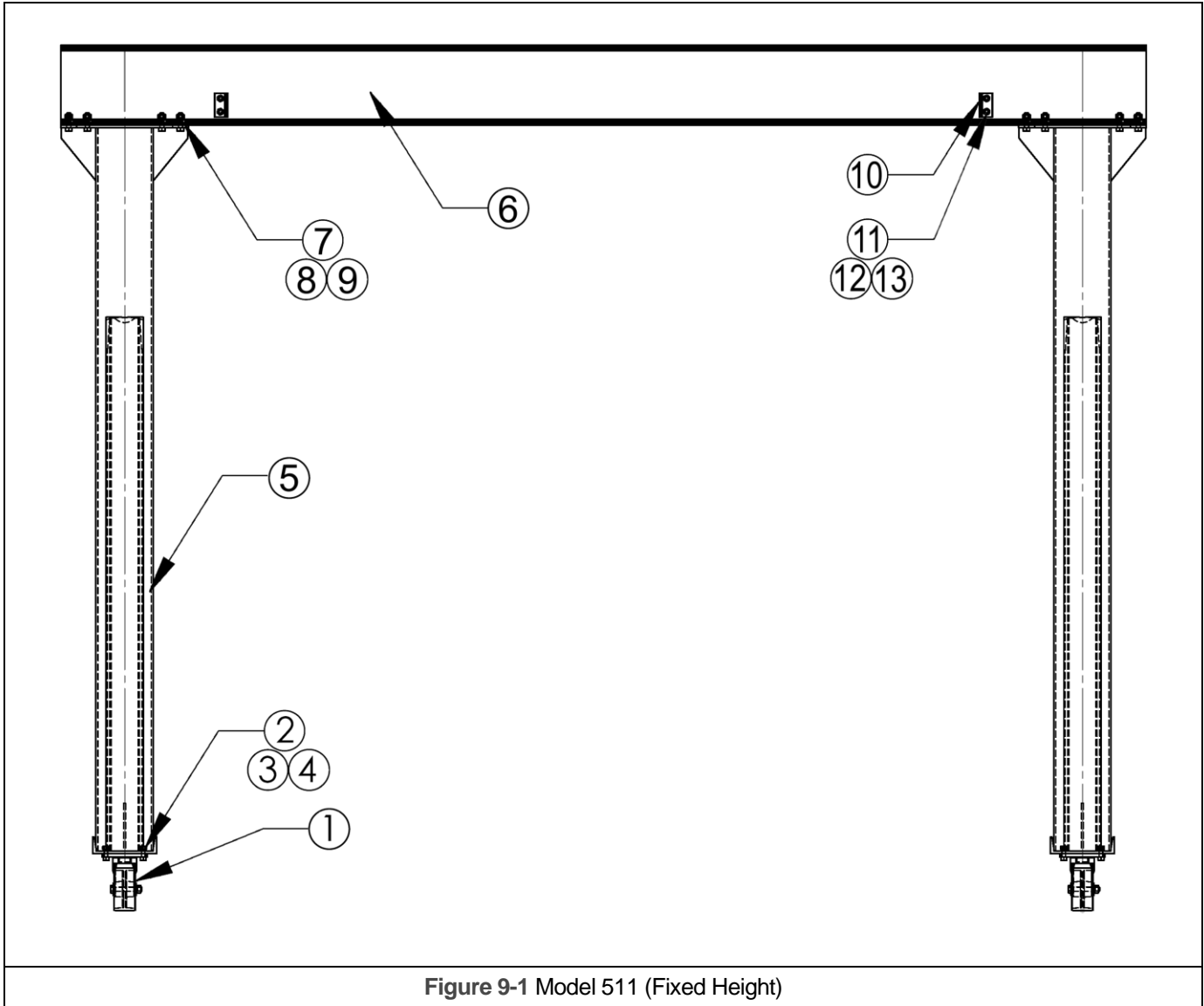

Figure 9-1 Model 511 (Fixed Height)

## 9.1 Model 511Crane Parts

			CAPACITY FOR MODEL 511 (TON)			
FIGURE NO.	DESCRIPTION	QTY	1/2	1	2	3
1	Caster	4	TT0550000		TT0550001	TT0550002
2	Bolt	16	TT0960022		TT0960023	
3	Locking washer	16	TT0980004		TT0980003	
4	Nut	16	TT0970004		TT0970003	
5	Leg Assembly	2	SEE BILL OF MATERIALS ON CRANE DRAWING			
6	Beam	1				
7	Bolt	-				
8	Locking washer	-				
9	Nut	-				
10	End Stop	4				
11	Bolt	8				
12	Locking Washer	8				
13	Nut	8				

9.2 Model 512 Crane Parts

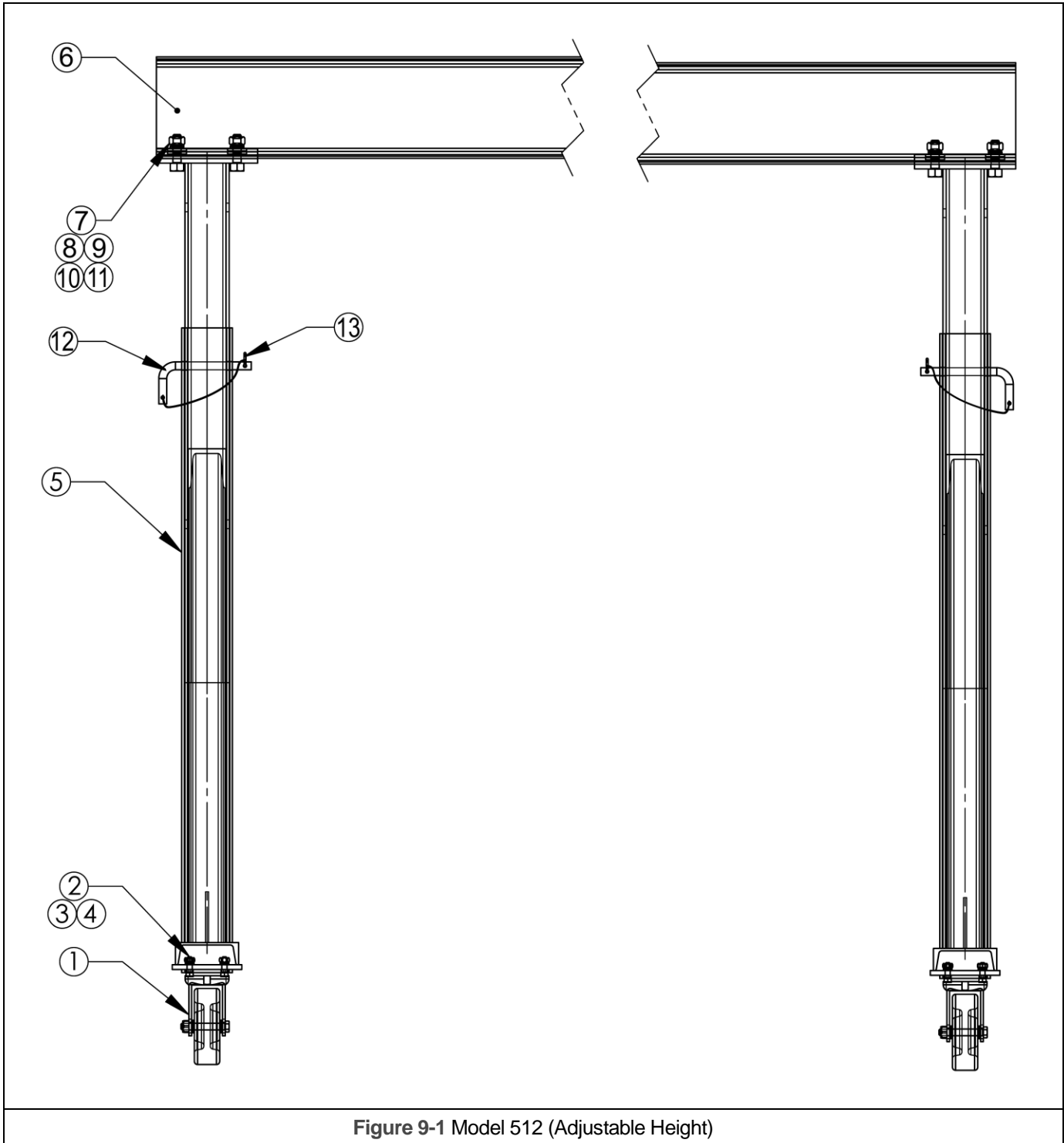

Figure 9-1 Model 512 (Adjustable Height)

## 9.2 Model 512 Crane Parts

FIGURE NO.	DESCRIPTION	QTY	CAPACITY FOR MODEL 512 (TON)		
			1	2	3
1	Caster	4	TT0550000	TT0550001	TT0550002
2	Bolt	16	TT0960022	TT0960023	
3	Locking Washer	16	TT0980004	TT0980003	
4	Nut	16	TT0970004	TT0970003	
5	Leg Assembly	2	SEE BILL OF MATERIALS ON CRANE DRAWING		
6	Beam	1			
7	Bolt	-			
8	Plate	-			
9	Square Beveled Washer	-			
10	Locking Washer	-			
11	Nut	-			
12	Pin	2			
13	Cotter Pin	2			

### 9.3 Labels

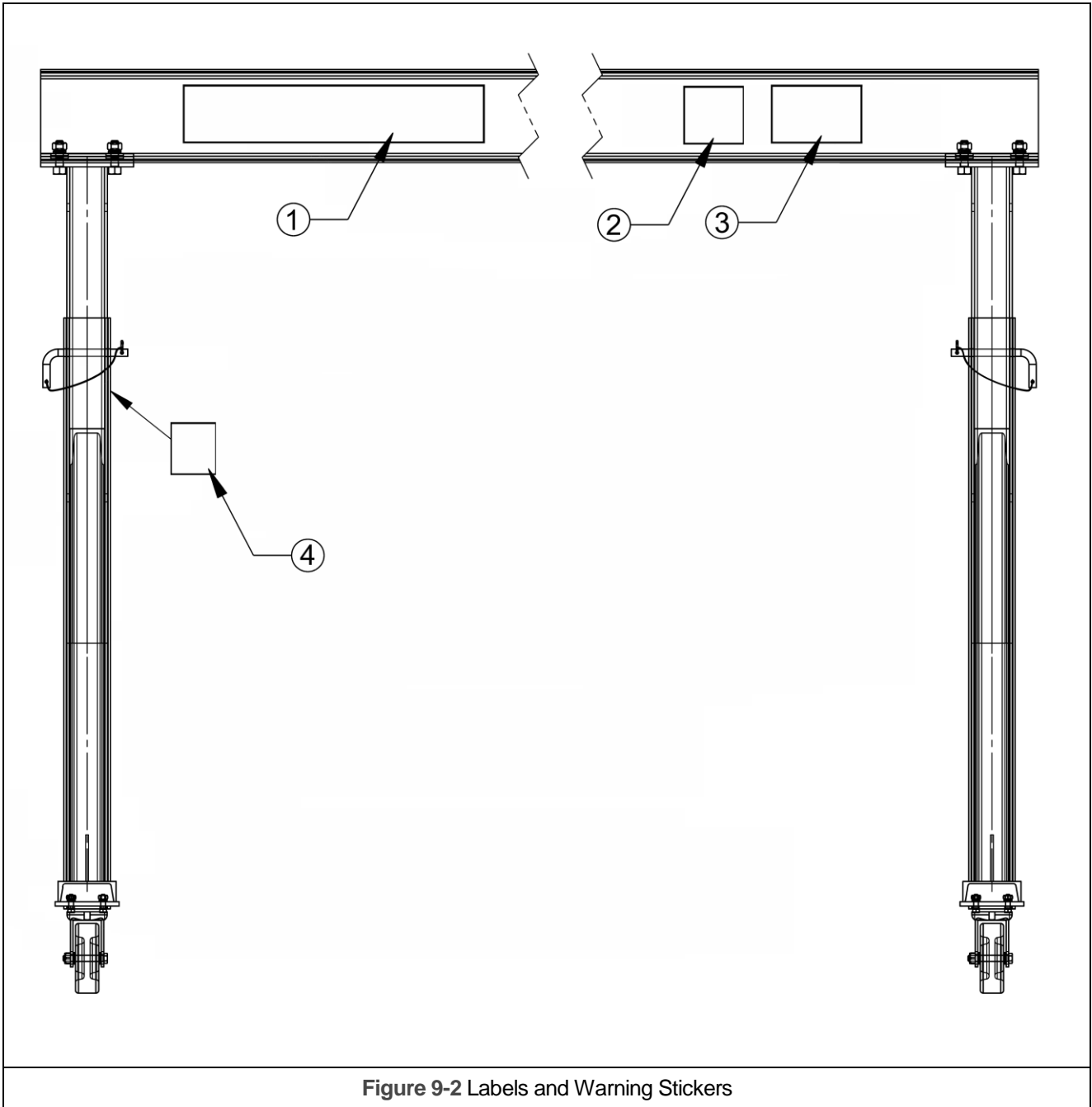

Figure 9-2 Labels and Warning Stickers

9.3 Labels

Figure No.	Description	Qty	BEAM HEIGHT   (INCHES)								
			6	8	10	12	14	16	18	20	24
1	Logo	2	8047301			8047302					
2	Capacity Number, 1	-	8047306								
	Capacity Number, 2		8047307								
	Capacity Number, 3		8047308								
	Capacity Number, 4		8047309								
	Capacity Number, 5		8047310								
	Capacity Number, 6		8047311								
	Capacity Number, 7		8047312								
	Capacity Number, 8		8047313								
	Capacity Number, 9		8047314								
	Capacity Number, 0		8047315								
	Capacity Slash		8047316								
3	Capacity Unit, TON	2	8047303								
	Capacity Unit, LBS		8047304								
	Capacity Unit, KG		8047305								
4*	Warning label	2	80472								

\*Only applies to Adjustable Height Gantry (Model 512)

**This Page Intentionally Left Blank**

**This Page Intentionally Left Blank**

# **TIGER** **TRACK**

[www.tigertrack.net](http://www.tigertrack.net)

## **Headquarters**

401 West End Avenue  
Manheim, PA 17545-1703  
Phone: 717-665-2000  
Toll Free: 800-233-3010  
Fax: 717-665-2861

## **Western Division**

2341 Pomona Rd. #103  
Corona, CA 92880-6973  
Phone: 951-279-7100  
Toll Free: 800-317-7111  
Fax: 951-279-7500

**TT511-512OM**