

BATTERY CHARGER / GEN HEATER CONNECTION
NEMA STYLE - I5-30, MALE FLANGED RECEPTACLE
30A 125VAC 1P3W

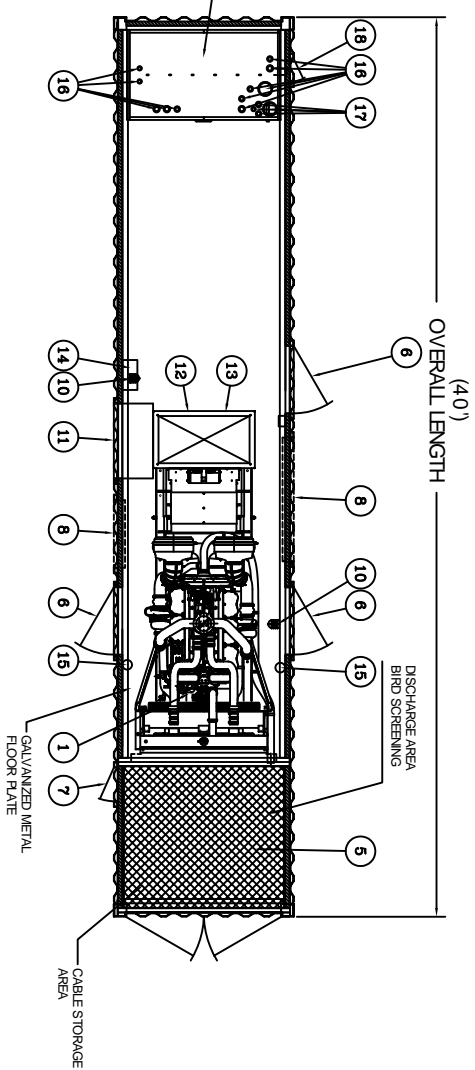

TOP VIEW OF TRAILER UNIT

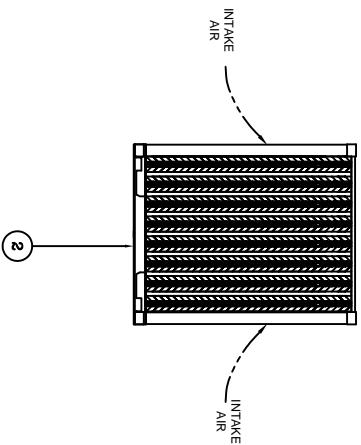

FRONT VIEW OF TRAILER UNIT

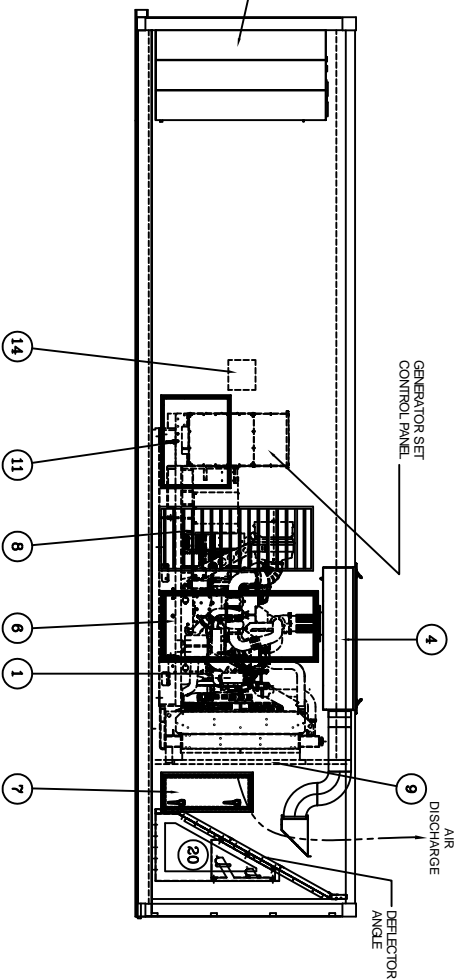

LEFT VIEW OF TRAILER UNIT

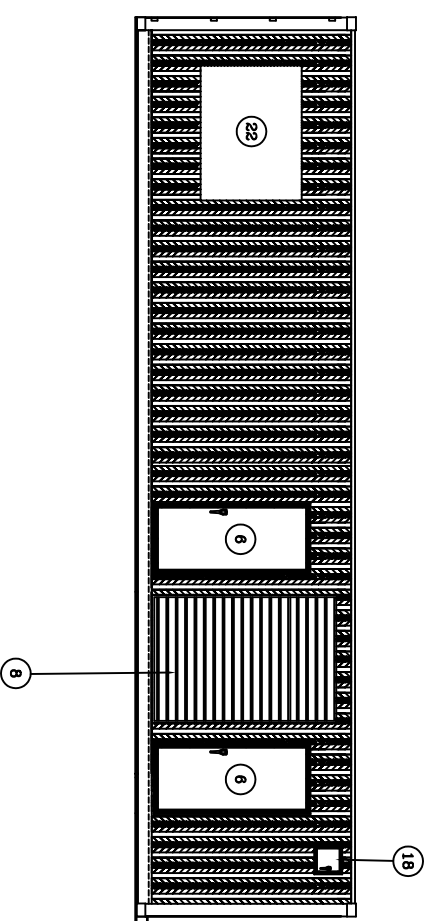

RIGHT VIEW OF TRAILER UNIT

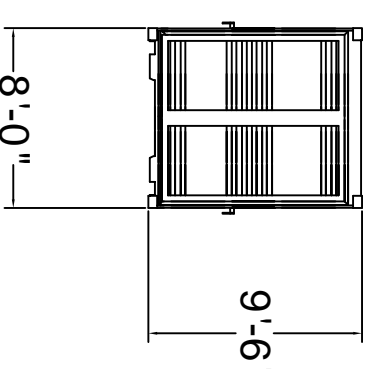

REAR VIEW OF TRAILER UNIT

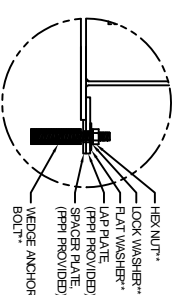

ANCHOR BOLT DETAIL
CONTRACTOR SHALL SUPPLY BOLTS

FINISH COLOR:	CAT. WHITE
EST. SHIPPING WEIGHT- EXCLUDING FUEL	57,000 LBS
APPROXIMATE OVERALL DIMENSIONS 90°	LENGTH: 480"
	WIDTH: 102"
	HEIGHT: 114"
MAIN TANK CAPACITY:	1,250 GAL.
RUPTURE BASIN CAPACITY:	110% 1,375 GAL.
SOUND LEVEL:	82 dBA @ 7m

ITEM	QTY:	DESCRIPTION
1	1	1000KW CAT. C32 GENERATOR SET
2	-	-
3	1	UL 142 FUEL TANK- 1,250 GALLONS. W/ STEP FOR TOP ACCESS
4	1	INTERIOR MOUNTED EXHAUST SILENCER
5	1	VERTICAL RADIATOR & EXHAUST DISCHARGE AREA
6	3	PERSONNEL DOOR ASSEMBLY- PAD LOCKABLE
7	1	CHAMBER ACCESS DOOR
8	2	FIXED INTAKE LOUVER- SOUND ATTENUATED, ACOUSTICAL
9	1	METAL DISCHARGE SCREEN
10	2	DC LIGHTS W/ TIMER
11	1	CONNECTION STATION ACCESS DOOR- W/ RUBBER FLAP & STRUT
12	1	PAD LOCKABLE, FOR CUSTOMER CONNECTION
13	1	CIRCUIT BREAKER- 3600A/F
14	1	RECONNECT PANEL W/ ROTARY TAP SWITCH
15	2	BATTERY CHARGER- PATTEN PROVIDED
16	11	FIRE EXTINGUISHER- FLOOR MOUNT
17	4	MAIN TANK FUEL FITTINGS & VENTS
18	1	RUPTURE TANK FUEL FITTINGS & VENTS
19	-	FUEL FILL ACCESS DOOR
20	-	-
21	2	JACKET WATER HEATER- 120VAC, PATTEN PROVIDED
22	2	DECAL PLATE- 54" X 79"

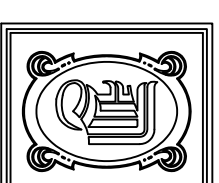

DAMMON ENGINEERING, INC.

CHIEF ENGINEER
EMMETT
DAMMON, P.E.
CHIEF ARCHITECT
ROBERT
WILTSE

1095 FLORIDA AVENUE
SUDELL, LA. 70458
OFFICE: 985-649-5932
FAX: 985-641-5950

WWW.DAMMONENGINEERING.COM
EMAIL:
DAMMONENG@DELLSOUTH.NET

ARCHITECTURE
ENGINEERING
STUDIES
PLANNING
INVESTIGATION
EXPERT WITNESS

TEXTRON MARINE
& LAND
252 STONE ROAD
SUDELL, LA. 7046C

GENERATOR
ELEVATIONS
FOR REFERENCE
ONLY

1000 KW
GENERATOR

1000 KW GENERATOR WILL BE SUPPLIED BY
OWNER AND INSTALLED BY THE CONTRACTOR

A-2

REV:
SCALE AS NOTED
JOB#: 1969
DATE: 10-08-08
SHEET

OF