

**SITE PLAN**  
SCALE: 1"=20'

**SITE PLAN NOTES**

1. ROOFING MATERIAL: METAL ROOFING PANEL
2. SIDING MATERIAL: CONVENTIONAL STUCCO VENEER
3. UTILITIES: ALL UTILITIES SHALL BE PLACED UNDERGROUND

**PEDESTRIAN ACCESS REQUIREMENTS**

PEDESTRIAN ACCESS REQUIRED: 600 SQ. FT.  
ACTUAL PEDESTRIAN ACCESS PROVIDED: 661 SQ. FT.

**RETAIL CENTER PARKING REQUIREMENTS**

9,000 SF BUILDING TOTAL  
9,000 SF TOTAL @ 300 SF/SPACE = 30.00 SPACES REQUIRED  
TOTAL PARKING REQUIRED = 30 SPACES (2 HANDICAP)  
TOTAL PARKING PROVIDED = 33 SPACES (2 HANDICAP)

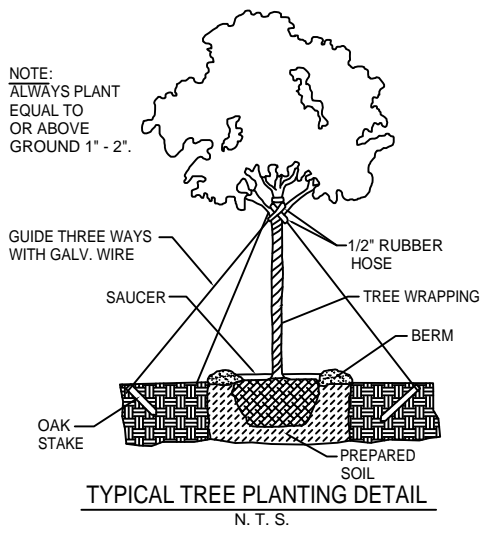

**LANDSCAPE LEGEND**

- CRAPE MYRTLE
- DWARF GARDENIA
- BICOLOR IRIS
- INDIAN HAWTHORNE
- SPLITLEAF
- VAR. GINGER
- GRASS
- PINE MULCH

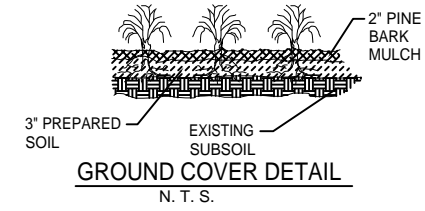
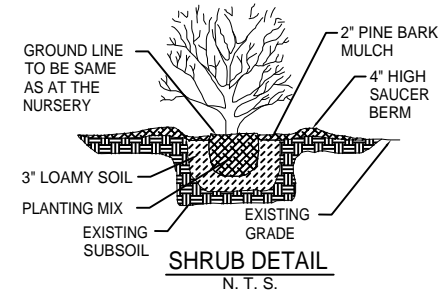

**SITE LEGEND**

- PROPERTY LINE
- UTILITY / EASEMENT LINE
- BUILDING SETBACK MINIMUM
- TRIANGULAR SITE LINE
- LANDSCAPING SETBACK MINIMUM AND BUFFER ZONE LIMITS AT REAR
- OPAQUE BUFFER FENCE
- BUILDING OUTLINE
- HANDICAP PARKING
- HANDICAP PARKING SIGN
- TRASH RECEPTACLE

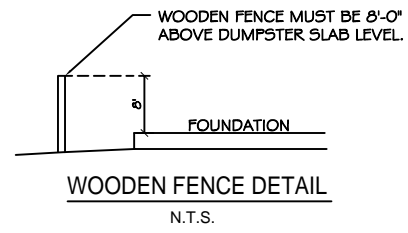
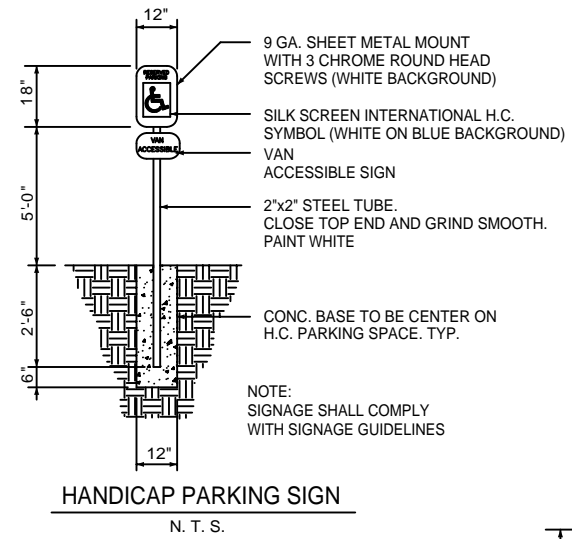

**LANDSCAPE REQUIREMENTS:**

**PERIMETER PLANTING AREA** - A PERIMETER PLANTING AREA AT LEAST TEN (10) FEET IN WIDTH MUST BE PROVIDED OFF THE PUBLIC RIGHT-OF-WAY BETWEEN THE RIGHT-OF-WAY AND PARKING AREA OR STRUCTURES. PLANTING MATERIALS SHOULD ACHIEVE A BALANCE OF LOW-LYING HORIZONTAL SHRUBBERY AND VERTICAL TREES. TREES SHALL BE PLACED NO MORE THAN 20-25 FEET ON CENTER WITH A COMPLIMENT OF NO LESS THAN 10 SHRUBS PER TREE.

**PARKING LOT PLANTING** - PARKING LOT INTERIORS SHOULD BE DESIGNED TO PROVIDE AT LEAST ONE (1) TREE FOR EVERY TWELVE (12) PARKING SPACES. EACH TREE SHOULD BE LOCATED IN A LANDSCAPED ISLAND OF AT LEAST 200 s.f. TREES MUST BE DISTRIBUTED UNIFORMLY SO AS TO PROVIDE A CANOPY EFFECT.

**PEDESTRIAN ACCESS PLANTING** - LANDSCAPED AREAS MUST BE PROVIDED BETWEEN THE BUILDING FACES HAVING ACCESS AND THE PARKING LOT. FOUR (4) s.f. OF LANDSCAPED AREA SHOULD BE PROVIDED FOR EVERY LINEAR FOOT OF BUILDING FACE. NO PLANTING AREA SHOULD BE LESS THAN FIVE (5) FEET WIDE AND PLANTING MATERIALS SHOULD ACHIEVE A BALANCE BETWEEN LOW-LYING SHRUBBERY AND VERTICAL TREES.

**SITE LIGHTING**

EXTERIOR LIGHTING SHALL BE SHADED OR INWARDLY DIRECTED IN SUCH A MANNER SO THAT NO DIRECT LIGHTING OR GLARE BE CAST BEYOND THE PROPERTY LINE. THE INTENSITY OF SUCH LIGHTING SHALL NOT EXCEED ONE FOOT CANDLE AS MEASURED AT THE ABUTTING PROPERTY LINE. (N/A FOR THIS PARTICULAR JOB)

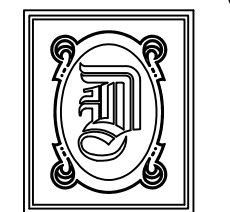
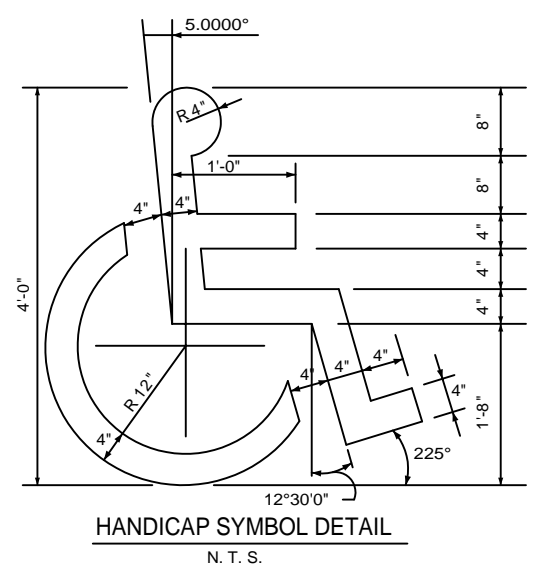

**DAMMON ENGINEERING, INC.**

CHIEF ENGINEER  
EMMETT DAMMON, P.E.

CHIEF ARCHITECT  
ROBERT WILTSE

1095 FLORIDA AVENUE  
SLIDELL, LA. 70458  
OFFICE: 985-649-5832  
FAX: 985-641-5950

WEBSITE:  
WWW.DAMMONENGINEERING.COM

EMAIL:  
DAMMONENG@BELLSOUTH.NET

- ARCHITECTURE
- ENGINEERING
- STUDIES
- PLANNING
- INVESTIGATION
- EXPERT WITNESS

J D PLAZA  
345 GAUSE  
BOULEVARD  
WEST  
SLIDELL, LA

**SITE PLAN**

REV:

SCALE: AS NOTED

JOB#: 2037

DATE: 10-29-09

SHEET 3

**C-2**

OF 19