

FOUNDATION PLAN
SCALE: 1/8"=1'

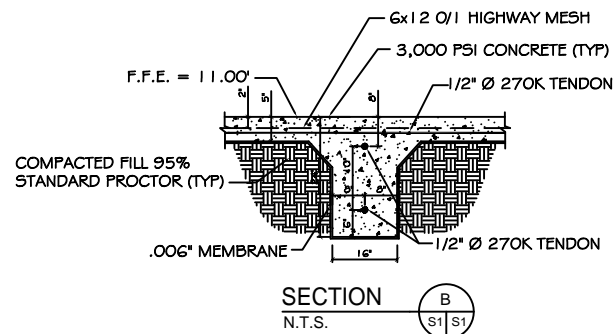
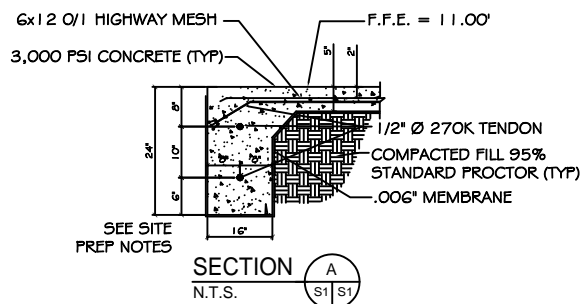
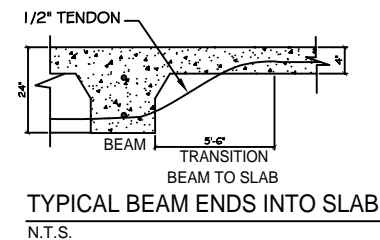
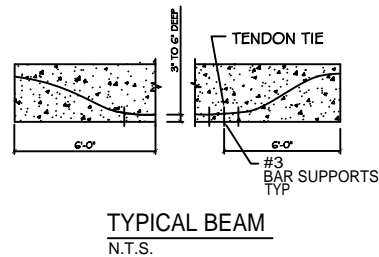
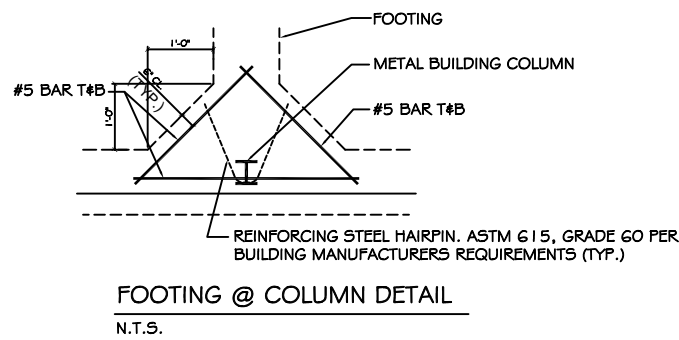

FOUNDATION GENERAL NOTES:

1. THE INTENT OF THIS PLAN IS TO PROVIDE INFORMATION FOR PLACEMENT OF POST TENSION SYSTEM TENDONS AND (WHERE SHOWN) PILING. ONLY IT IS THE RESPONSIBILITY OF THE GENERAL CONTRACTOR TO VERIFY ALL DIMENSIONS, BRICK LEDGES, BLOCK OUTS, OFFSETS, ETC., SHOWN ON THESE PLANS, TO ASSURE AGREEMENT WITH ARCHITECTURAL PLANS.
2. BEAM SIZES AND LOCATION AND NUMBER OF PILES SHALL NOT BE CHANGED WITHOUT APPROVAL OF THE ENGINEER. EXCEPT THAT BEAM DEPTH MAY BE EXTENDED TO REACH UNDISTURBED SOIL. SPECIAL LOADS NOT INDICATED ON DRAWING I.E., BRICK FIREPLACES, AND OR CHIMNEYS, HOT TUBS ETC., REQUIRE ADDITIONAL REINFORCEMENT.
3. IT IS RECOMMENDED THAT A CURING COMPOUND BE USED TO CONTROL SHRINKAGE.
4. AS A MINIMUM, INSTALLATION OF RIGID FLOOR TILES, BRICK, ETC. SHALL BE OVER ELASTIC BOND BREAKER. ANY CRACKS IN CONCRETE FLOOR SHALL BE TREATED PRIOR TO INSTALLATION OF TILES. ELASTOMETIC ADHESIVE IS RECOMMENDED FOR CERAMIC FLOOR TILES. WHERE DECORATIVE CONCRETE IS USED, ADDITIONAL REINFORCEMENT WILL BE REQUIRED.
5. WHERE ADDITIONAL REINFORCEMENT WITH REBAR IS USED IN FOOTINGS, IT SHALL CONFORM TO ASTM A615. WOVEN WIRE FABRICS SHALL CONFORM TO ASTM A185.
6. TENDONS AND BARS SHALL BE SECURELY SUPPORTED TO BE PREVENT BOTH VERTICAL AND HORIZONTAL MOVEMENT DURING PLACING OF CONCRETE.
7. ALLOW 8" CENTERED CLEARANCE ON TENDON AXIS BY 36" LENGTH FOR REINFORCING EQUIPMENT CLEARANCE.
8. CONCRETE SHALL BE WELL CONSOLIDATED ESPECIALLY IN THE VICINITY OF TENDON ANCHORAGES.
9. CONCRETE DESIGN IS BASED UPON A CONCRETE MIX HAVING A MINIMUM OF 5.3 SACKS OF CEMENT PER CUBIC YARD AND A MAXIMUM OF 30 GALLONS OF TREE AND ADDED WATER PER CUBIC YARD. SUCH A MIX SHOULD GIVE A MINIMUM COMPRESSION STRENGTH OF 3,000 P.S.I. AT 28 DAYS. CONCRETE DESIGN MIX SHALL BE IN ACCORDANCE WITH THE A.C.I. BUILDING CODE REQUIREMENTS.
10. CONCRETE TO HAVE A MINIMUM COMPRESSIVE STRENGTH OF 1500 P.S.I. AT THE TIME OF STRESSING.
11. ALL CONVENTIONAL REINFORCING STEEL SHALL BE ASTM DESIGNATION A-615 (GRADE 60) REINFORCING AND SHALL BE DETAILED AND ACCESSORIES PROVIDED IN ACCORDANCE WITH THE LATEST A.C.I. MANUAL OF STANDARD PRACTICE FOR DETAILING REINFORCED CONCRETE STRUCTURES.
12. ALL PRESTRESSING STEEL SHALL CONSIST OF SEVEN-WIRE STRESS RELIEVED STRAND CONFORMING TO ASTM A-416. MINIMUM ULTIMATE TENSILE STRENGTH SHALL BE 270,000 P.S.I. STRANDS SHALL BE COATED WITH A PERMANENT RUST PREVENTIVE LUBRICANT AND A PLASTIC SHEATH.
13. REINFORCEMENT SHALL HAVE 3" COVER IN GRADE BEAM BOTTOMS, 2" COVER IN BEAM SIDES AND TOPS, 1 1/2" COVER IN SLAB TOPS AND BOTTOMS, UNLESS OTHERWISE SHOWN.
14. COORDINATE STRUCTURAL DRAWINGS WITH ARCHITECTURAL AND MECHANICAL DRAWINGS FOR ALL OPENINGS, INSERTS AND ANY OTHER RELATED ITEMS.
15. PLANS FOR PIPES, CONDUITS, THIMBLES, ETC. TO PASS THROUGH CONCRETE SLAB OR BEAM, MUST NOT CONFLICT WITH REINFORCING. WHERE A CONFLICT OCCURS, PIPES, CONDUIT, ETC. ARE TO TAKE PRECEDENCE.
16. PROVIDE A SINGLE LAYER OF VAPOR BARRIER UNDER CONCRETE SLAB.
17. THE TENDON LOCATION AT THE END OF GRADE BEAM IS TO BE A MINIMUM OF 6" FROM THE TOP OF SLAB TO CENTER OF GRAVITY OF TENDONS.
18. TENDONS TO BE STRESSED NO EARLIER THAN 7 DAYS AND NOT LATER THAN 14 DAYS AFTER PLACEMENT OF CONCRETE.
19. FORMS TO BE STRIPPED NO LATER THAN 6 DAYS AFTER PLACEMENT OF CONCRETE.
20. STRESSING:
 1. 1/2" TENDON SHALL BE ANCHORED AT 28.9K PER STRAND, BUT SHALL BE INITIALLY STRESSED TO 33.0K PER STRAND.
 2. 3/8" TENDON SHALL BE ANCHORED AT 16.1K PER STRAND, BUT SHALL BE INITIALLY STRESSED TO 18.4K PER STRAND.
21. LOADING OF SLAB PRIOR TO TENSIONING SHALL NOT BE DONE WITHOUT THE APPROVAL AND DIRECTION OF THE SUPERVISING ENGINEER.

SITE PREP NOTES:

1. REMOVE EXISTING NEAR SURFACE LOOSE TAN SAND AND MEDIUM, STIFF SILTY CLAYS THAT EXTEND TO A DEPTH OF 1 FT. TO 1 1/2 FT. EXPOSE EXISTING STIFF AND VERY STIFF CLAYS. UNDER ALL NEW CONSTRUCTION AND PAVING, PROOF-ROLL AND REMOVE ANY SOFT, YIELDING OR PUMPING SPOTS.
2. NEW CONCRETE FOOTINGS ARE TO BE SEATED IN THE FIRM, NATURALLY OCCURRING STIFF TO VERY STIFF CLAY OR SILTY CLAYS TO PROVIDE AN ALLOWABLE SOIL BEARING VALUE OF 1,500 LBS. PER SQ. FT.
3. PROVIDE AND MAINTAIN IMMEDIATE SITE DRAINAGE BEFORE, DURING AND AFTER CONSTRUCTION. PROVIDE GRADING SWALES AND SUMP PUMPS AS MAY BE REQUIRED TO IMMEDIATELY DRAIN ALL RAIN WATER FROM THE CONSTRUCTION AREA.
4. ALL EXCAVATED MATERIAL SHOULD BE REPLACED WITH CONTROLLED-COMPACTED STRUCTURAL FILL INSTALLED IN 6"-8" LIFTS. THIS STRUCTURAL FILL WHICH COULD ALSO BE USED TO RAISE THE SITE GRADE, COULD CONSIST OF RED CLAY-SAND TYPE MATERIAL HAVING LESS THAN 30 PERCENT FINES PASSING THE No. 200 SIEVE. IT SHOULD BE COMPACTED TO AT LEAST 95 PERCENT OF MAXIMUM DRY DENSITY AT OPTIMUM MOISTURE CONTENT ACCORDING TO ASTM D-698.
5. ESTIMATED SETTLEMENTS OF UP TO ONE INCH ARE POSSIBLE WITH A MODERATE SUSCEPTIBILITY TO VOLUMETRIC CHANGE RESULTING IN HEAVE AND SHRINKAGE DURING VARIATIONS OF HEAVY PRECIPITATION AND DROUGHT. GOOD ROOF AND SURFACE DRAINAGE WITH POSITIVE COLLECTION AND RUNOFF AND SLOPES AWAY FROM THE BUILDING SHOULD BE ASSURED.
6. MONITORING OF PROOF-ROLLING AND SELECTION, PLACEMENT AND COMPACTION OF FILL BY A SOILS ENGINEER, IS RECOMMENDED.

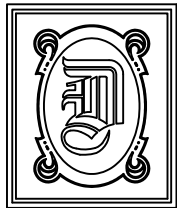

DAMMON ENGINEERING, INC.

CHIEF ENGINEER
EMMETT DAMMON, P.E.

CHIEF ARCHITECT
ROBERT WILTSE

1095 FLORIDA AVENUE
SLIDELL, LA. 70458
OFFICE: 985-649-5832
FAX: 985-641-5950

WEBSITE:
WWW.DAMMONENGINEERING.COM
EMAIL:
DAMMONENG@BELLSOUTH.NET

- ARCHITECTURE
- ENGINEERING
- STUDIES
- PLANNING
- INVESTIGATION
- EXPERT WITNESS

J D PLAZA
345 GAUSE
BOULEVARD
WEST
SLIDELL, LA

FOUNDATION PLAN

REV:

SCALE: AS NOTED

JOB#: 2037

DATE: 10-29-09

SHEET 8

S-1

OF 19