

FLEXX BLOCK

Insulated Concrete Form

by Lite-Form Technologies®

Flexx Block forming components should only be assembled and installed by workers who have been properly trained. It is the installer's responsibility to make sure that training is done before construction begins. Serious injury or death may result from safety hazards caused by improper assembly and installation of forming components! Before beginning, check local engineering and building codes on cast-in-place concrete construction. This guide covers typical building situations and is not meant to replace specific codes for engineering or safety.

Folding Flexx Block Form (16" X 48")

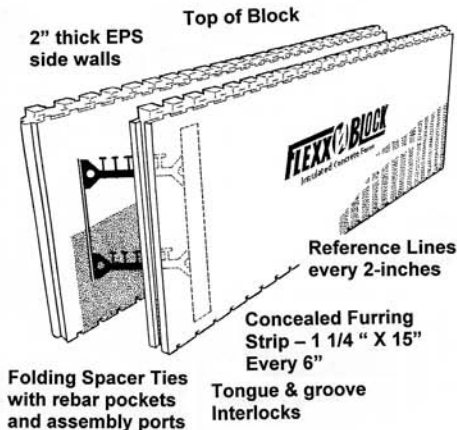

Begin assembly at the 90-degree corners and work to the center of each wall.

Corners are assembled with Pre-Molded Corner Sections. Instructions are provided to assemble forms without common seams throughout the wall. An optional method is also provided to assemble forms with common seams every 4 feet, throughout the wall.

Save all cut sections. They may be used to assemble corners. Blocks can be cut along reference lines (every 2") with handsaw or hot-wire blade.

Cut Spacer Ties when needed, with mechanical shears or tin snip.

If you have questions about the assembly and installation techniques in this guide, contact your Flexx Block supplier or Lite-Form Technologies

Footing or Pad Preparations

Footing or pad must be level, uniform and wide enough for the form to rest on. Footing must also be proper width and thickness for soil conditions. Check with local code officials for guidelines and specifications. First course (row) of forms will be glued to the footing/pad, along the chalk line.

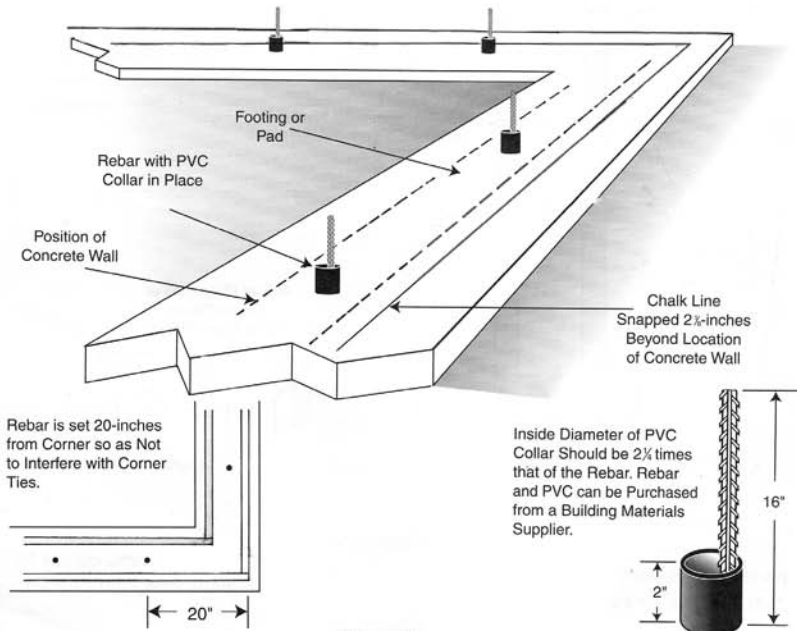

90-Degree Corner Assembly with Pre-molded Corner Section

Pre-Molded Corner Section

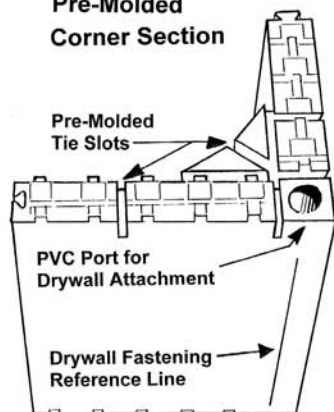

8-inch Corner Tie

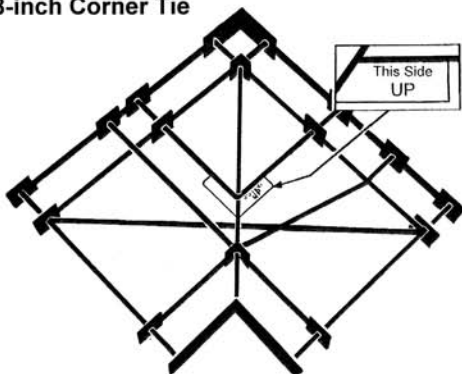

Begin assembly at the corners and work to the center of each wall.

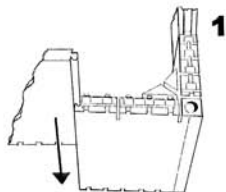

1

First Row

Step 1 - Slide 2 Blocks into Pre-molded Corner Section

Step 2 - Glue assembled corner to concrete footing or pad. To insure alignment, anchor 2X4 wood cleats at outside point of corner**

**** Wood cleats are not needed, if a Corner Tie is inserted in the bottom of the assembled corner, flush with bottom of insulation.**

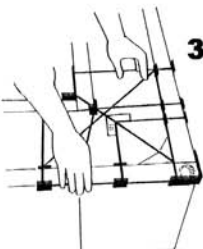

3

Step 3 - Place Corner Tie on assembled corner and press down firmly until insulation is dented.

Step 4 - Cut 3/4 inch deep slots at the dents with a drywall saw. Additional slots have been pre-molded in the Corner Section. Remove approx. 2" of the exposed tongue on the inner block. Press Corner Tie halfway into the slots.

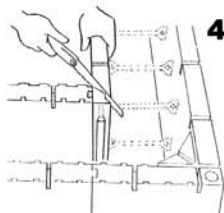

4

Second Row

Step 1 - Cut 2 Blocks in half and slide them into a Pre-molded Corner Section as shown. Place onto first assembled row. Press firmly until the Corner Tie and Castellations are interlocked.

Repeat Step 3 and Step 4

When placing full Blocks next to the cut half Blocks, remove the tongues and glue full and half Blocks together with expanding foam glue.

Continue corner assembly by alternating the use of full Blocks and half Blocks.

CORNER LOCKS must be attached at each Corner Tie, to reinforce the common seam. See Page 3 for steps on using Corner Locks.

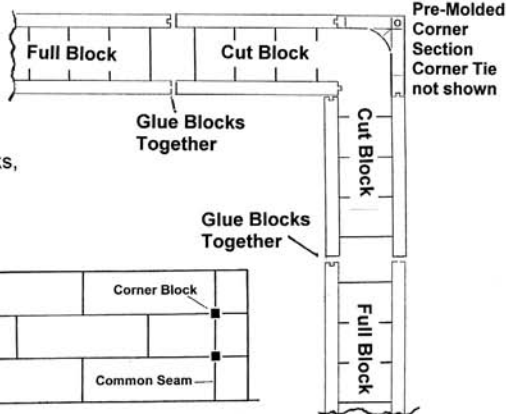

OPTIONAL 90-Degree Corner Assembly with Pre-molded Corner Section Common Seams

Corners and walls assembled in the following manner eliminates the step of cutting Blocks for every other row of forms. This results in common seams every 4 feet throughout the assembled wall. To assemble corners and walls in this manner, **Block Lock** and **Corner Lock** accessories are attached, as explained below.

First Row

Follow Steps 1, 2 3, and 4 as shown on Page 2.

Second Row

Repeat Step 1 using 2 full Blocks. Place onto first assembled row. Press firmly until the Corner Tie and Castellations are interlocked.

**Continue assembly using full Blocks.
Attach Block Locks at the interlock of each block.
Attach Corner Locks at common seam next to corner.**

Block Locks are used to reinforce all common seams between form blocks. Insert Lock fully into the Tie ports on both sides of seam and turn one-quarter turn to lock it in place.

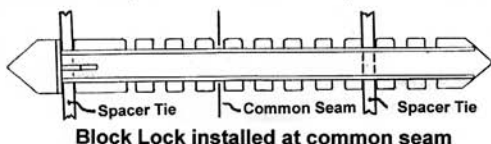

Seam Splicer Locked into Spacer Ties

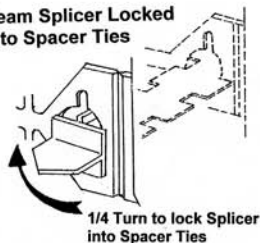

Corner Locks are used to reinforce the common seam next to corners. They are attached over the exposed tabs on both sides of the Corner Tie. They are anchored in place with 1 1/4 inch drywall screws attached to concealed Furring Strip and/or the exposed tabs of Corner Ties. Two Corner Locks are used at each Corner Tie.

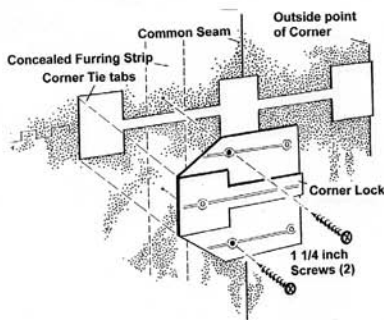
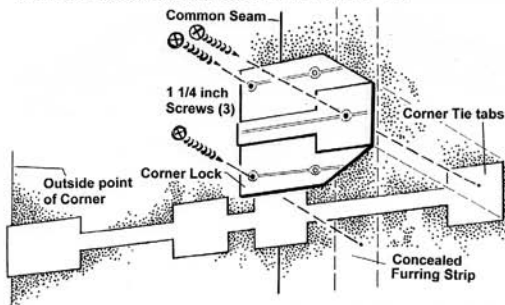

Block Locks and Corner Locks installed in assembled wall with common seams

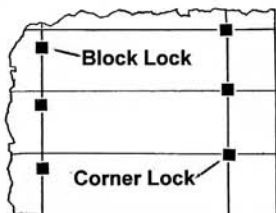

Drywall Attachment at the Corners

For installers who use the Pre-Molded Corner Sections: The exposed Corner Tie tabs can be removed and installer may attach drywall at the corners by inserting a 3/4 inch PVC plumbing pipe into the Attachment Port. Pipe runs the full height of the assembled wall. To insure proper anchoring, placing drywall screws along the Reference Line provided on the Pre-Molded Corner Sections.

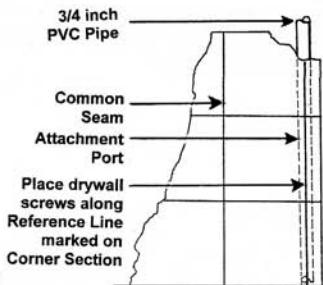

T-Intersection Assembly

All concrete wall widths

Accessories for Jobsite Fabrication and Assembly of T-Intersections

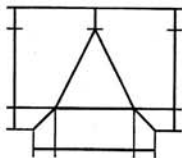

Wrap-around T-Ties.
Use 1 per course and at bottom and top of wall

There is no "top" or "bottom" to the T-Tie

24" lengths of #4 (1/2 inch) Reinforcing Steel (rebar).
Use 2 pieces per course

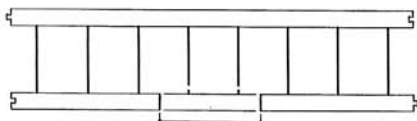

Length of cut section is 4-inches plus the concrete wall width

Step 1 – Cut a section of a Block and cut **one end** of Spacer Ties as shown. The length of the cut section will be 4-inches plus the concrete wall width.

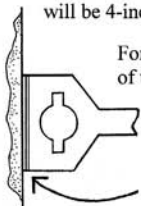

For an 8-inch concrete wall, the length of the cut section will be 12-inches.

Cut Ties at hinge, next to insulation

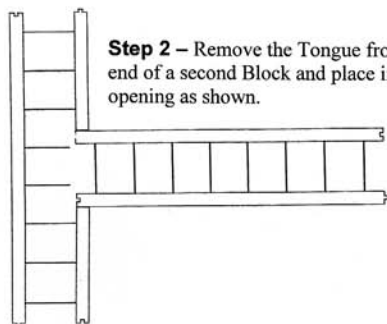

Step 2 – Remove the Tongue from the end of a second Block and place in cut opening as shown.

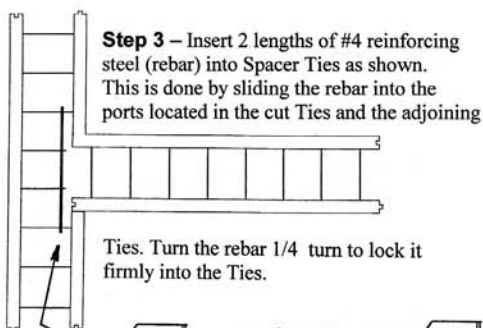

Step 3 – Insert 2 lengths of #4 reinforcing steel (rebar) into Spacer Ties as shown. This is done by sliding the rebar into the ports located in the cut Ties and the adjoining

Ties. Turn the rebar 1/4 turn to lock it firmly into the Ties.



Slide rebar through Ports and twist one-quarter turn to lock

Vertical brace
Wood or metal 2X4 runs full height of wall.
Wire-Tied to form

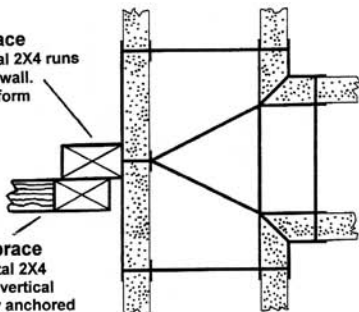

Diagonal brace
Wood or metal 2X4 anchored to vertical and securely anchored at bottom of wall

OPTIONAL Reinforcing of T Intersection

If steel rebar steel is not used to reinforce the intersection, installer must attach outside vertical brace as shown. Vertical brace can be anchored with wire loops or drywall screws. Diagonal brace is anchored to vertical brace with drywall screws.

Wall Assembly

When assembled wall reaches 32-inches high, begin installing wire ties for exterior vertical braces (page 11) and begin installing horizontal rebar (reinforcing steel) as required by code.

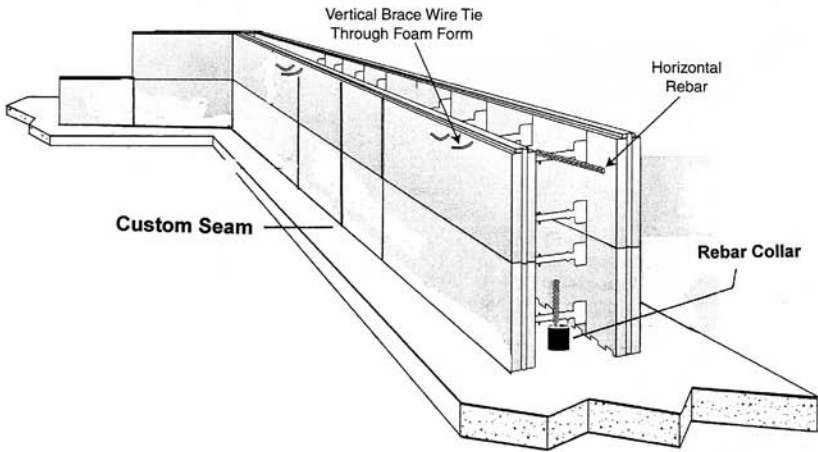

Custom Seams – Begin assembly at corners and work toward the center of the wall. At the center of the wall between corners, the center block may have to be custom-trimmed to fit. This will create a custom seam up the wall. Reinforce this custom seams with **Block Locks** on both sides of the wall explained on Page 3 of this guide.

Wire Ties

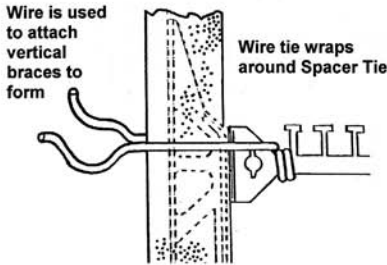

Wire ties for exterior vertical braces – Begin installing wire ties with the second course of forms. A 24-inch length of 16-gauge wire is pressed through the form wall and wrapped around a Spacer Tie, leaving the ends extending out. As assembly continues wire ties should be placed approx. every 32-inches up the wall, with rows placed approx. **8-feet*** apart, along the entire wall.

*Maximum spacing of **6 feet** is allowed by OSHA guidelines, if brace is also being used to support a work platform.

Horizontal rebar is placed into the rebar pockets on Spacer Ties and wire-tied (to Ties) every 36-inches to 48-inches. **Follow local building codes for proper size and placement of all reinforcing steel.**

Optional horizontal In-Wall Bracing

Bracing sections should be installed horizontally approx. every 4-feet up the wall around the entire wall and at the top of the wall. Bracing should be the same width as the concrete wall and is “friction-fit” by firmly pressing it into the form cavity, until it is seated on a row of Spacer Ties. Wire-tie the Bracing to a Spacer Tie approx. every 36-inches. If Bracing is not used, vertical 2X4 vertical braces should be placed every 4-feet, on one side of the entire form.

To reduce the risk of voids, DO NOT place horizontal rebar and In-Wall Bracing on the same level.

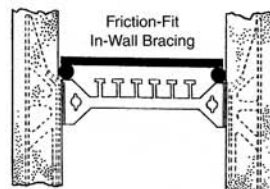
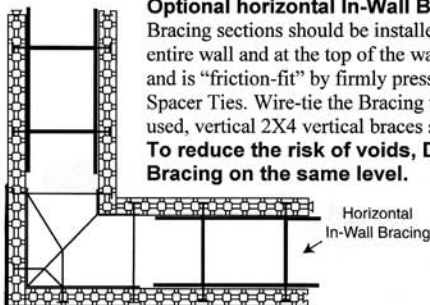

Exterior Vertical Bracing

When assembled wall reaches 4-feet high, exterior vertical braces must be attached along one side of the form. They are placed approx. **8-feet*** apart and are anchored to the form with the wire ties which were installed earlier. Braces can be good-quality dimensional lumber (2X4) or 18-gauge steel. Additional braces should be used next to window or door jambs. A diagonal "kicker" brace is anchored to each vertical brace. If optional steel In-Wall Bracing is not used, vertical braces should be placed approx. every **4-feet apart**, to insure proper alignment.

*Maximum spacing of **6 feet** is allowed by OSHA guidelines, if brace is also being used to support a work platform.

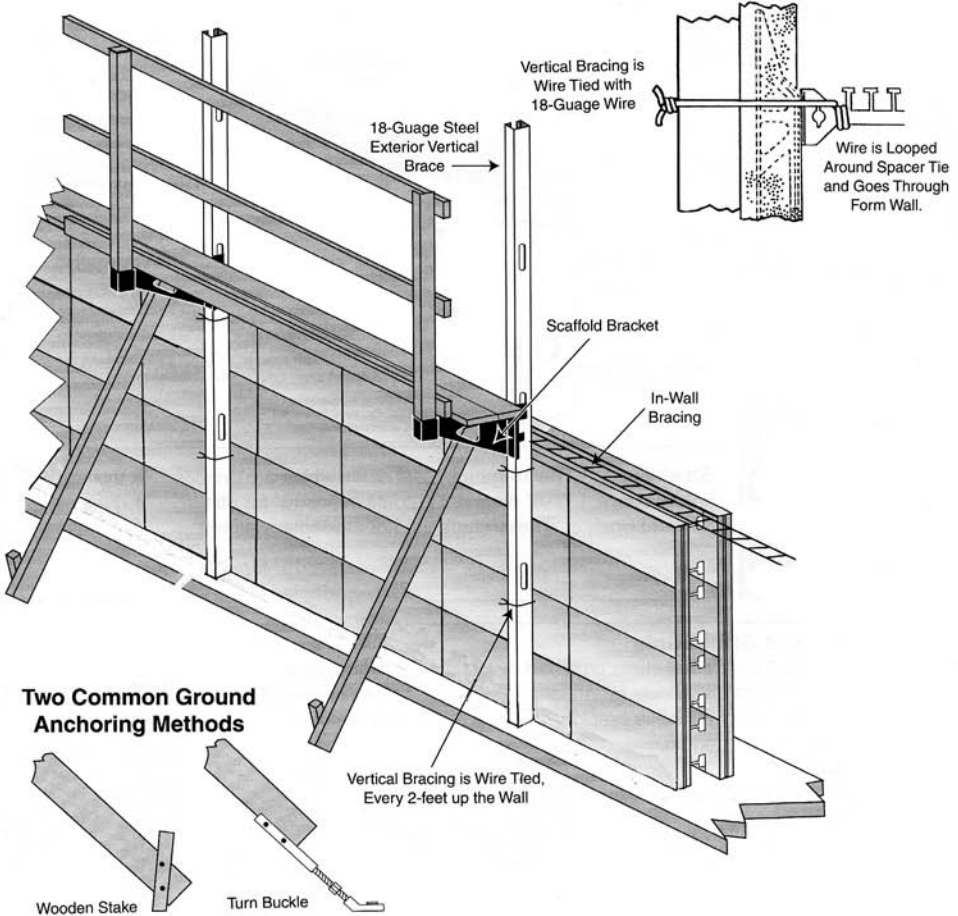

Positive Interlocks

Flexx Block forms have true 'tongue and groove' interlocks at the ends. Because of this the blocks slide together during assembly. This feature eliminates the need to glue the blocks together, to maintain proper alignment.

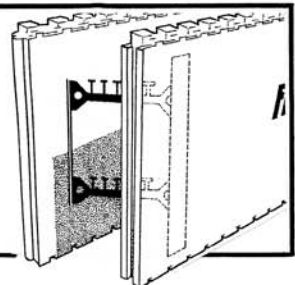

Window & Door Casing and Bracing

Openings can be built during form wall assembly or they can be cut in with a hand saw, after the form is assembled.

Prior to Concrete Placement

Before placement of concrete, wood blockouts are securely anchored at head and jambs. A temporary 2x4 wood brace is added to openings over 2-feet tall. Wood sill blockout is not placed at this time.

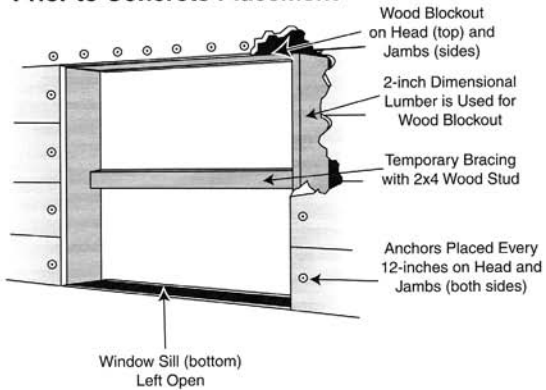
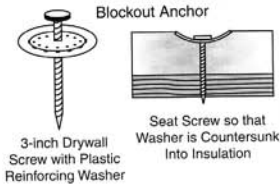

After placement of concrete up to the sill height, wood blockout is positioned at the sill, between the forms walls and anchored. Before placing anymore concrete, temporary 2x4 wood braces are added to openings over 2-feet wide.

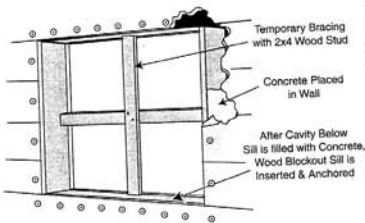

Alternate Technique for Window and Door Casing

The 2-inch dimensional lumber (for blockouts) can be installed flush with trimmed edges of insulation. The 2-inch lumber is anchored in place with strips of 1-inch plywood or 1 X 4 dimensional lumber anchored to bulkhead and plastic Spacer Ties with drywall screws. Strips of 2-inch lumber are used to extend the width of blockout lumber (concrete wall width + 4-inches).

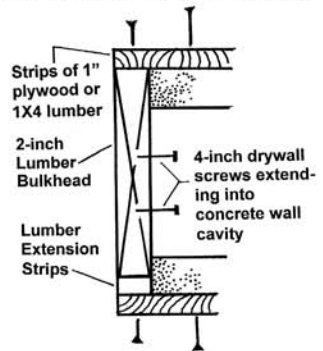

Blow-Out Repair Kit

A blow-out repair kit should be made BEFORE the concrete arrives. It is used to repair a form blow-out or break and is constructed of two pieces of wood 2X4s approximately 18-inches long, a length of 1/4 inch threaded rod, nuts and washers as shown.

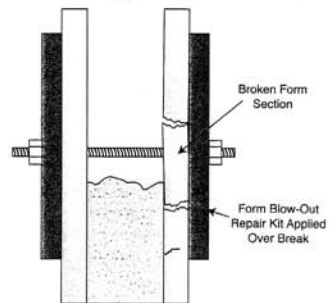
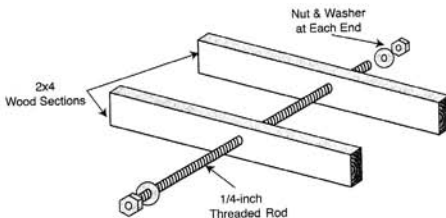

Form breaks rarely happen but when they do, it's important to stop pouring the concrete as soon as possible...remove the built-up concrete from the opening and re-position or replace the broken form pieces. Repair kit is placed over both sides of break as shown. Holes created by the blow-out should be filled with expandable insulation or fresh concrete to insure against water penetration later.

Top Assembly of Form Wall

When assembled wall reaches full height, vertical rebar is lowered in-between the foam planks and inserted into the PVC collar up against the other rebar protruding from footing or pad.

Full Corner Ties or T-intersection Ties are placed at the top of the wall and steel In-Wall Bracing is 'friction fit' around the entire wall. The vertical 2X4 braces are anchored to the form with lengths of wire through the form wall.

If wood frame structure will be constructed above the concrete wall, castellations should be removed with a sharp blade, to insure a smooth fit.

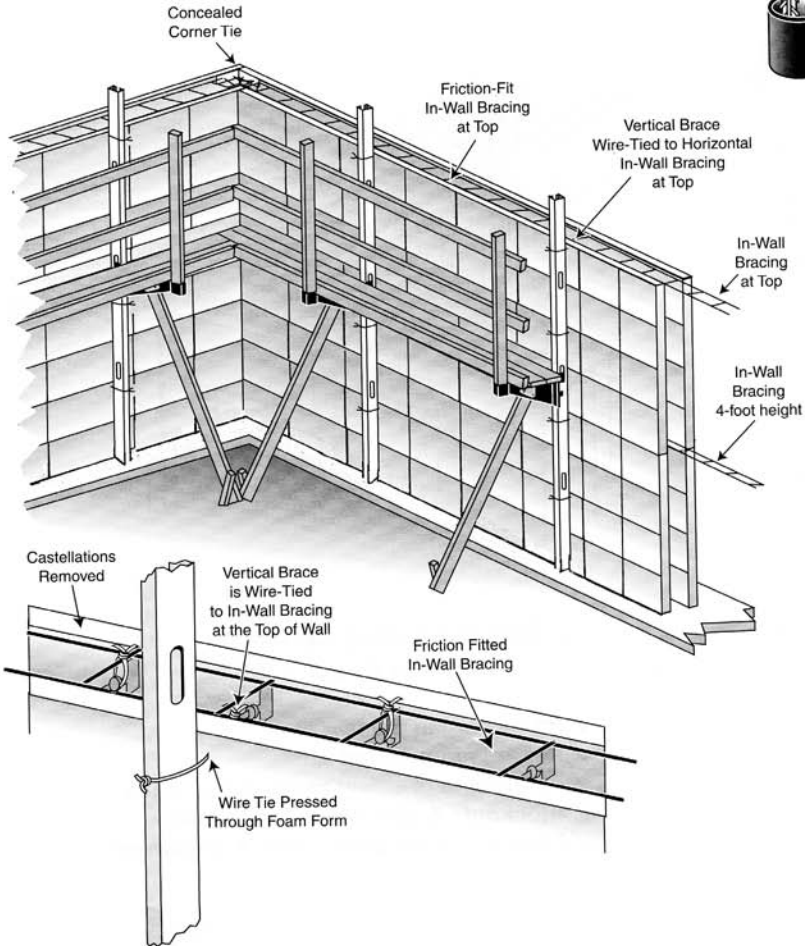
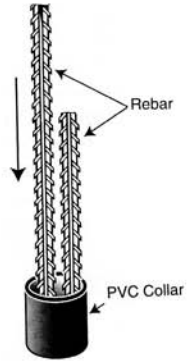

Final Check List of Your Project

Are Corners plumb from top to bottom?
Are vertical braces wire-tied every 2-feet?
diagonal braces adjusted and anchored?
Is top In-Wall Bracing installed and wire-tied?
Has final alignment been checked?
Is someone assigned to check for blow-outs?

Is all rebar installed?
Does each vertical brace have a diagonal brace?
Are window/door bulkheads reinforced?
Have utility holes been cut and blocked?
Is blow-out repair kit handy?
Is scaffold planking safely anchored?

Concrete Specifications

1/2 to 3/4 inch smooth aggregate
2,500 to 4,000 psi mix
4 to 6 inch slump

Placing the Concrete with a Pump

Concrete is often placed in the insulating form walls with a concrete pump. To minimize the risk of form failure, **the discharge pressure from the pump hose should be reduced**, by using one of the following techniques. Most pump operators are familiar with these techniques and can provide the necessary accessory, if they are notified, in advance.

90-Degree Elbows - This 2-elbow accessory is attached to the pump's delivery hose to reduce discharge volume and pressure.

Hose Reducer - A 3-inch reducer is attached to the pump's delivery hose. The 3-inch discharge hose reduces the concrete's discharge pressure.

Hose Harness - If the 90-degree elbow or hose reducer is not available, the discharge hose can be fitted with a rope or strap harness to bend it so that concrete is **not discharged straight down**, into the form. The hose is diverted and allows the concrete to fall naturally.

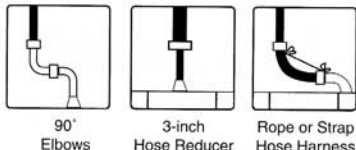

Lifts - Place concrete in lifts **not to exceed a height of 4-feet**, with no more than 8-feet of concrete placed vertically in one hour. This rate must be followed, regardless of how concrete is placed into the form. Placing concrete in lifts **over 4-feet per lift** can cause immediate form failure (blow-outs).

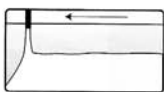

Move Around the form in the **same direction**, for each lift



Do NOT Stay in One Spot and Pour

e. Only experienced operators should be allowed to use an electric vibrator with 1-inch head to consolidate concrete. Concrete can also be consolidated from the outside by tapping the tie pads with a rubber mallet.

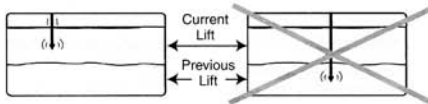

Do NOT Extend Vibrator Into Level of Previous Lift. Doing so can Cause Immediate Form Failure.

f. If a winter project is delayed for several days, assembled forms should be covered to avoid the accumulation of ice or snow at the bottom of the form. If this debris is not removed, they will cause voids in the wall when the concrete is placed.

Finishing

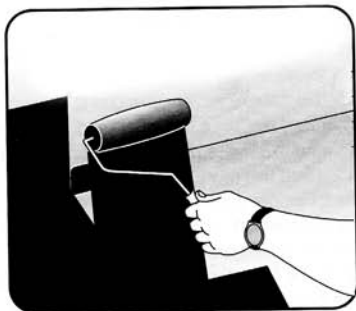

Damproofing

Select only latex or low-solvent liquid damproofing which is approved for application directly onto rigid polystyrene insulation. Apply a liberal coating directly onto the form, sealing the seams in the form wall.

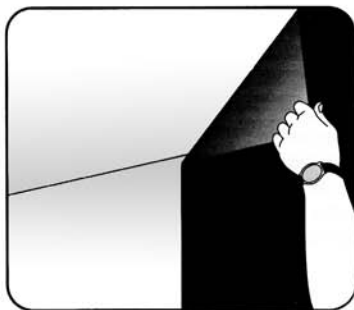

Waterproofing

Self-adhesive membranes (minimum 60 mil thickness) or approved liquid waterproofing materials can be applied directly to the form walls. Follow manufacturer's recommendations for application directly onto rigid polystyrene insulation.

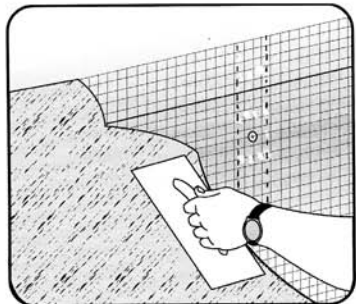

Stucco, EIFS, Synthetic Masonry

Insulation surface must first be roughened by sanding or scratching. For single coat products, a generous coat of material is recommended to thoroughly cover the exposed plastic tie pads. For products having a base coat and mesh, the mesh is anchored directly to the concealed tie pads. Follow manufacturer's instructions for proper placement, temperature control, etc. Forms walls which have been exposed to the environment for more than 90 days will normally have a light coat of fine "powder" which must be thoroughly brushed off before applying finish.

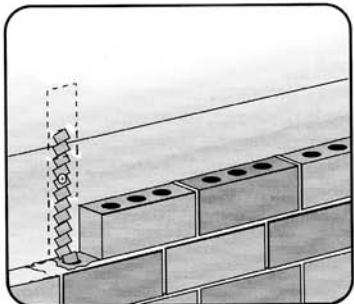

Brick

With a concrete brick ledge, brick veneer (fascia) can be added directly over the form walls. Brick anchors may be attached to the concealed plastic tie pads or may be inserted through the form wall, into the form cavity, prior to placement of concrete. Follow local building codes or accepted practices for the placement of brick anchors.

Drywall and Siding

Gypsum Board (drywall) is attached directly to the form walls. This is done by anchoring the drywall to the form's concealed, continuous vertical furring strips with a drywall screw. The furring strips are the tab-ends of the Spacer Ties and are located every 6-inches on both sides of the forms.

Exterior siding may be added directly to the form walls in the same manner as drywall. Follow manufacturer's recommendations for proper spacing and anchoring screws. Smooth nails should not be used to anchor siding.

Electrical and Plumbing Lines

Follow local codes for the types of electrical and plumbing components which are acceptable for the your project.

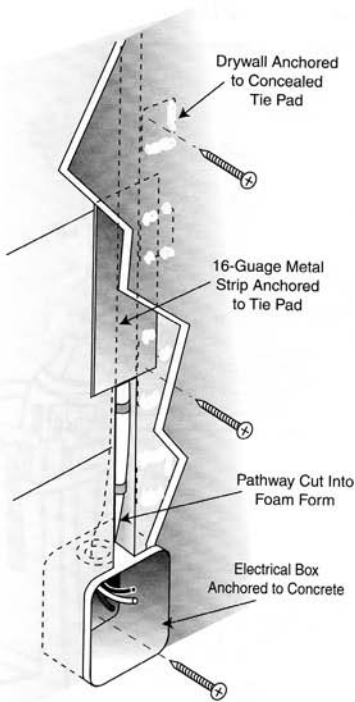

Electrical and plumbing lines are concealed in the insulation by cutting or carving a pathway approximately 1/2 -inches deep with a saw, router, or electric hot knife. For junctions or switch boxes, insulation is completely removed and items are anchored directly into the concrete. Electric lines can be protected by running them inside approved metal or plastic conduit. Damage to lines can also be avoided by covering the pathway with a 16-gauge metal strip, approximately 2-inches wide, anchored to the concealed tie pads with a drywall screw. *diagram 13-1)*

Electric lines can be held to the back of the pathway by using approved electrical anchors or expandable insulation placed approximately 2-feet apart.

Molded Projecting Brick Ledge

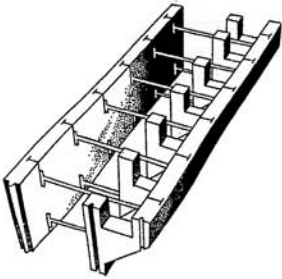

A 12-inch tall Fold-Form Projecting Brick Ledge block can be assembled into a Flexx Block project. A 4-inch tall **height adjuster block** is installed to modify the height of the Brick Ledge block. The height adjuster can be placed **above** or **below** the Brick Ledge block. For complete and installation instructions on the Brick Ledge block, please contact your Flexx Block supplier or Lite-Form Technologies.

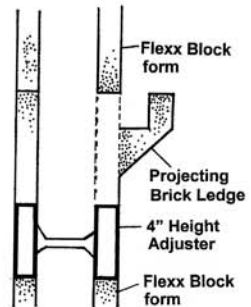

**If you have questions
about the assembly and installation techniques in this guide,
contact your Flexx Block supplier or Lite-Form Technologies.**

**For assembly and construction techniques
which are not covered in this guide,
contact your Flexx Block supplier or Lite-Form Technologies.**

LiteForm[®]
T E C H N O L O G I E S

Bright Ideas in Concrete Building Systems & Services

1950 W. 29th Street – South Sioux City, NE 68776
Phone (U.S. and Canada) – 800-551-3313 or 402-241-4402
FAX: 402-241-4435

U.S. Patent Numbers 4765109, 4916879, 4889310, 5039058, 5209039, 361710D, 4866891, 4885888, 4706429, 4730422, 5497592. Canadian Patent Number 1314727. Patents Pending. Flexx Block is a trademark of Lite-Form Technologies, LLC.

© 2008 Lite-Form Technologies – S. Sioux City, NE