

PHILLIPS

Phone 770.394.1616 Fax 770.394.1314

CONSULTANT

SEAL

ISSUE & REVISION RECORD

#	DATE	DESCRIPTION
	07/07/14	BID SET

This document is © Phillips Partnership, PC and is considered an instrument of service and is solely for use with respect to the project as indicated below. All rights reserved. This document may not be reproduced without the prior written consent of Phillips Partnership, PC.

PROJECT

SPRINGS AT FREMAUX TOWN CENTER  
SLIDELL, LA

CLIENT

CONTINENTAL PROPERTIES  
CONTINENTAL 294 FUND LLC  
W134 N8675 EXECUTIVE PARKWAY  
MENOMONEE FALLS, WI 53051  
262.502.5500 \* FAX 262.502.5522

PHILLIPS JOB NUMBER 1333104

ISSUE DATE 07/07/14

DRAWN BY/CHECKED BY ATL/DEB

DRAWING TITLE

CLUBHOUSE AND APARTMENT BUILDING PARTITION SCHEDULE

SHEET NUMBER

G0.30

NORTH TERRACES  
400 PERIMETER CENTER TERRACE  
SUITE 650  
ATLANTA, GEORGIA 30346

- WALL PARTITION NOTES:
- 5/8" TYPE 'X' MOISTURE RESISTANT GYP. BD. BEHIND AND ABOVE TUB SURROUNDS AND ON CEILINGS ABOVE TUB/SHOWER.
  - ALL INTERIOR WALLS AND INTERIOR SIDE OF EXTERIOR WALLS TO RECEIVE 5/8" TYPE 'X' GWB.
  - MAINTAIN RATED ASSEMBLIES AT ICEMAKER, WASHER BOX AND DRYER VENT BOX AT RATED WALLS

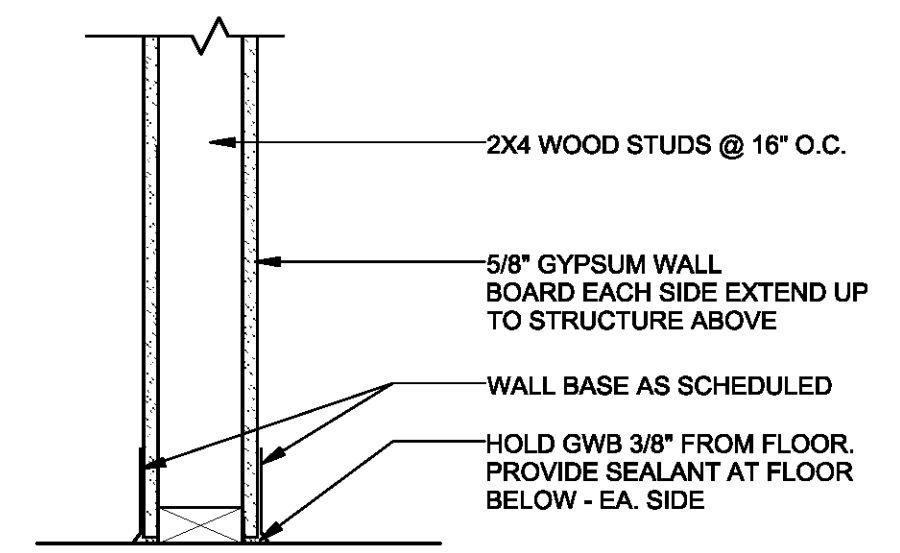

P11 TOILET ROOM PARTITIONS @ CLUBHOUSE  
1 1/2" = 1'-0"

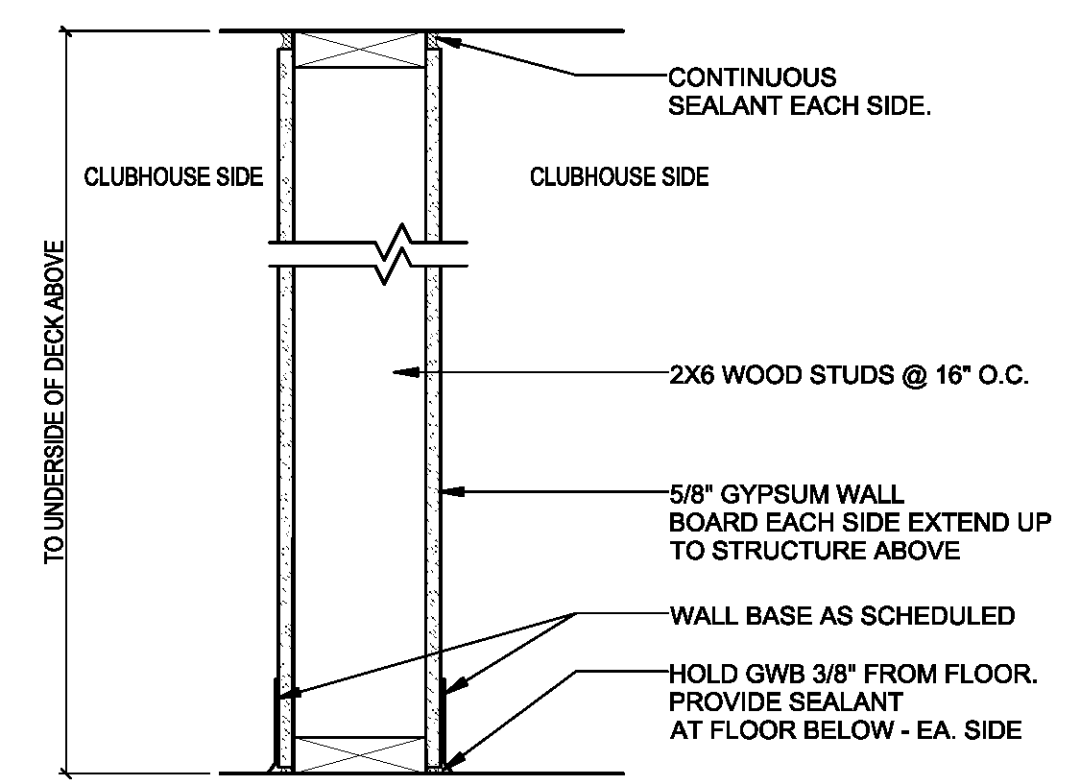

P10 NON-BEARING WALL @ CLUBHOUSE  
1 1/2" = 1'-0" VERIFY LOCATION WITH BUILDING PLANS

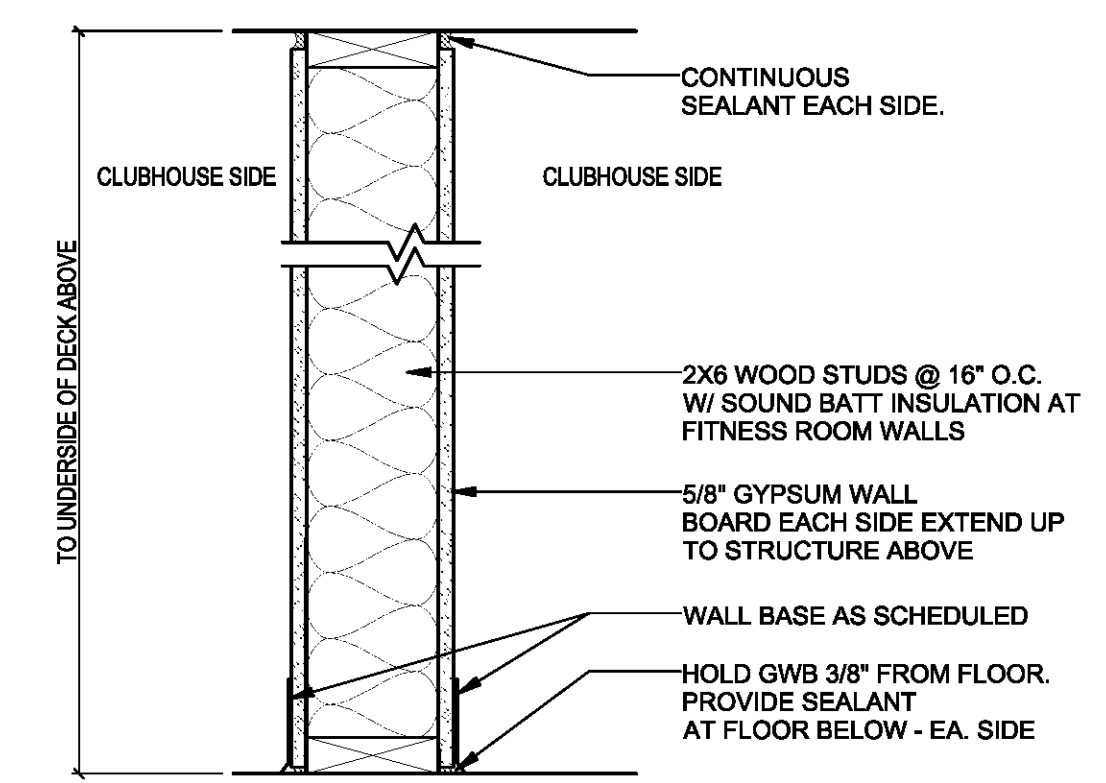

P9 BEARING WALL @ CLUBHOUSE  
1 1/2" = 1'-0" VERIFY LOCATION WITH BUILDING PLANS

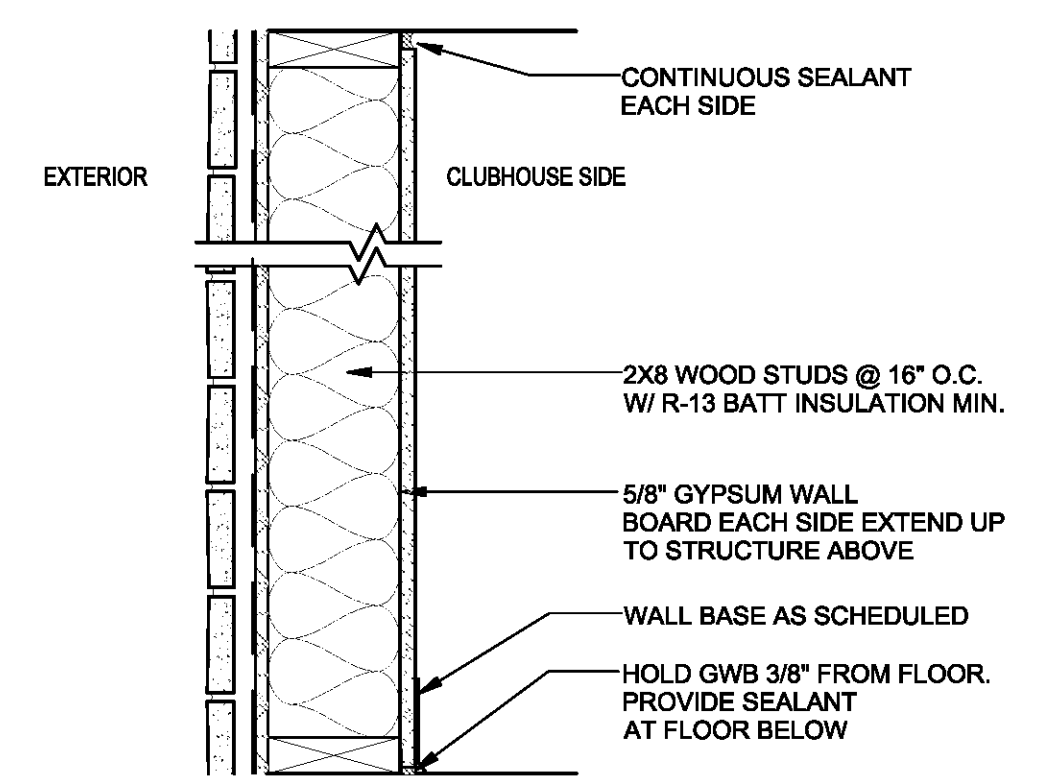

P8 BEARING WALL @ CLUBHOUSE  
1 1/2" = 1'-0" VERIFY LOCATION WITH BUILDING PLANS

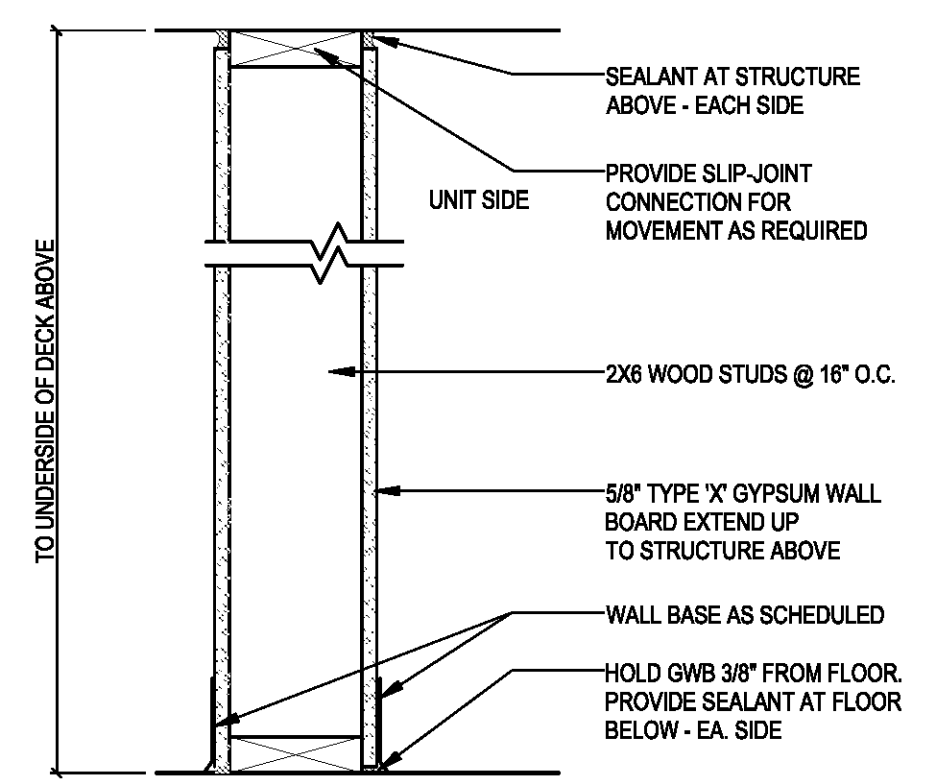

P7 TYPICAL PARTITION @ PLUMBING AND BEARING WALLS - VERIFY LOCATION WITH BUILDING PLANS  
1 1/2" = 1'-0"

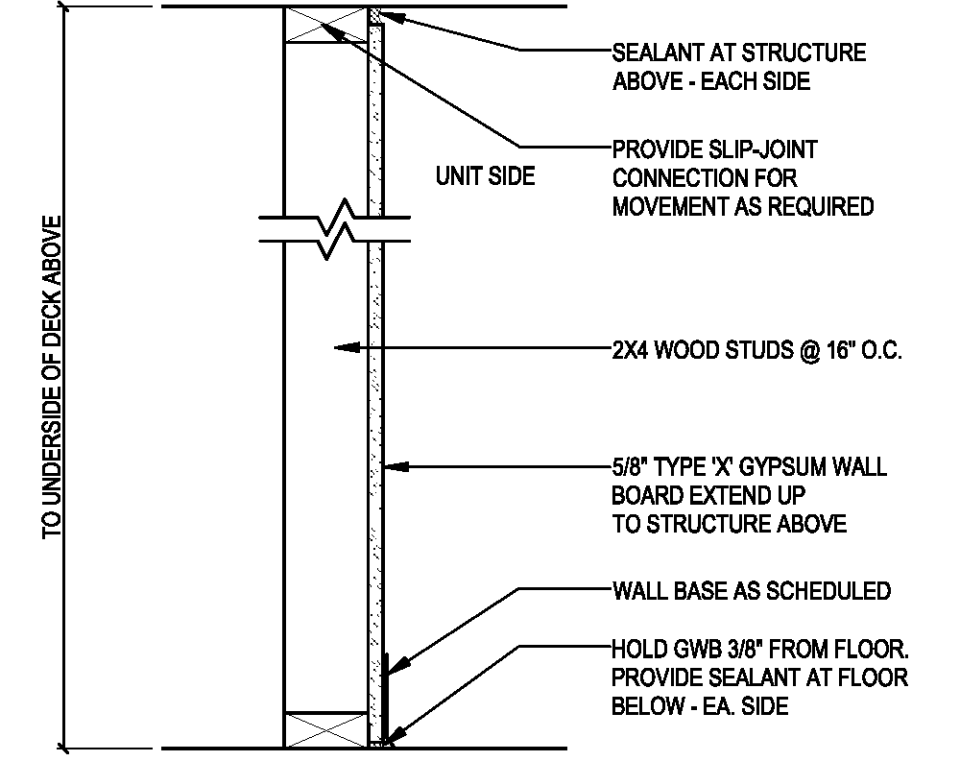

P6 TYPICAL PARTITION (NON RATED) @ INTERIOR WALLS  
1 1/2" = 1'-0"

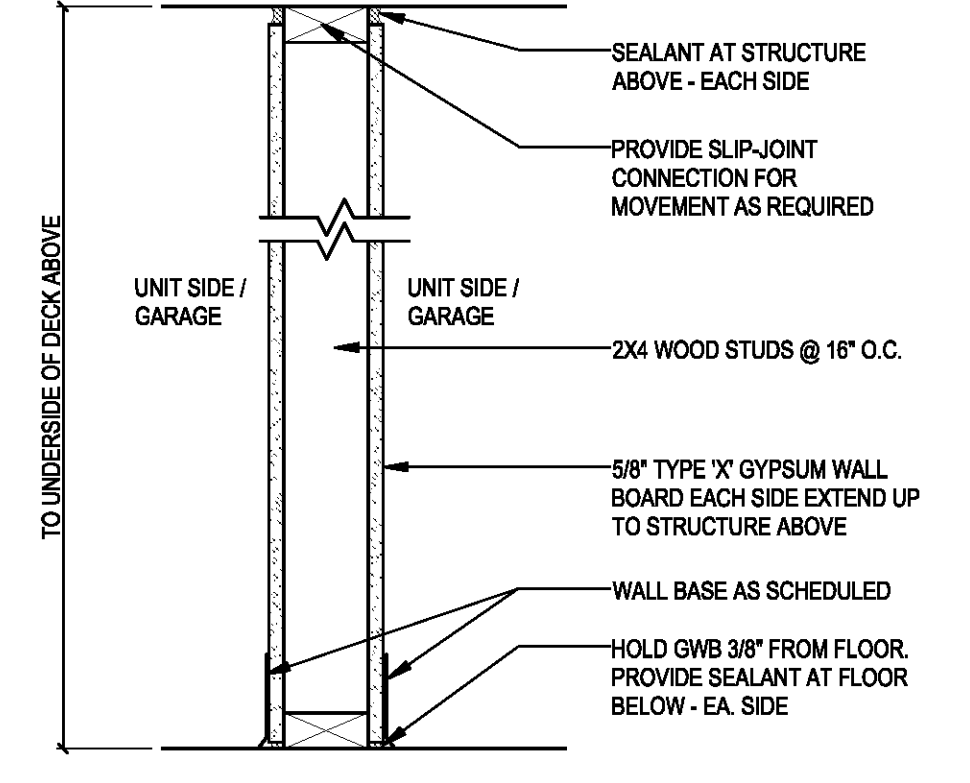

P5 TYPICAL PARTITION (NON RATED) @ INTERIOR WALLS  
1 1/2" = 1'-0"

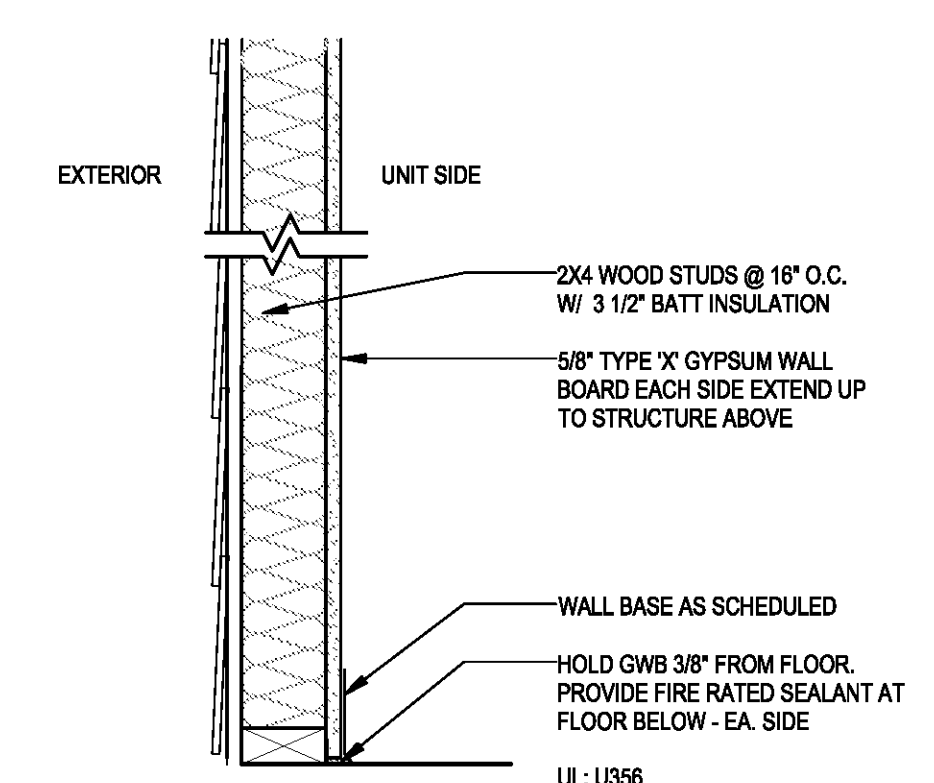

P4 1-HR RATED PARTITION @ BEARING WALL  
1 1/2" = 1'-0" VERIFY LOCATION WITH BUILDING PLANS

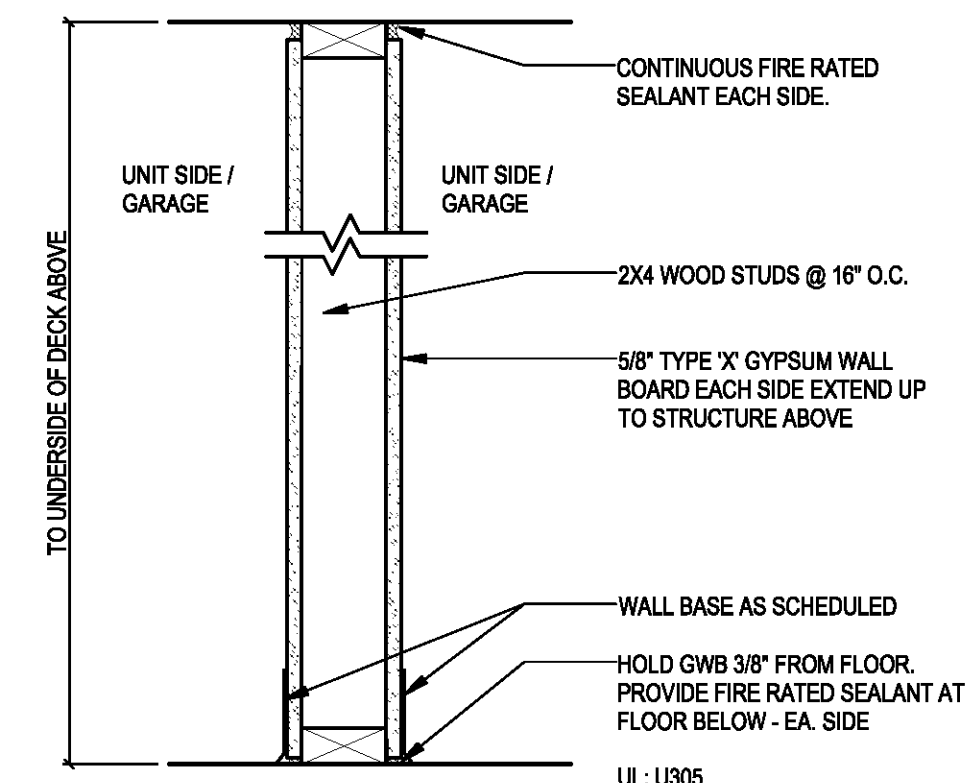

P3 1-HR RATED PARTITION @ BEARING WALL  
1 1/2" = 1'-0" VERIFY LOCATION WITH BUILDING PLANS

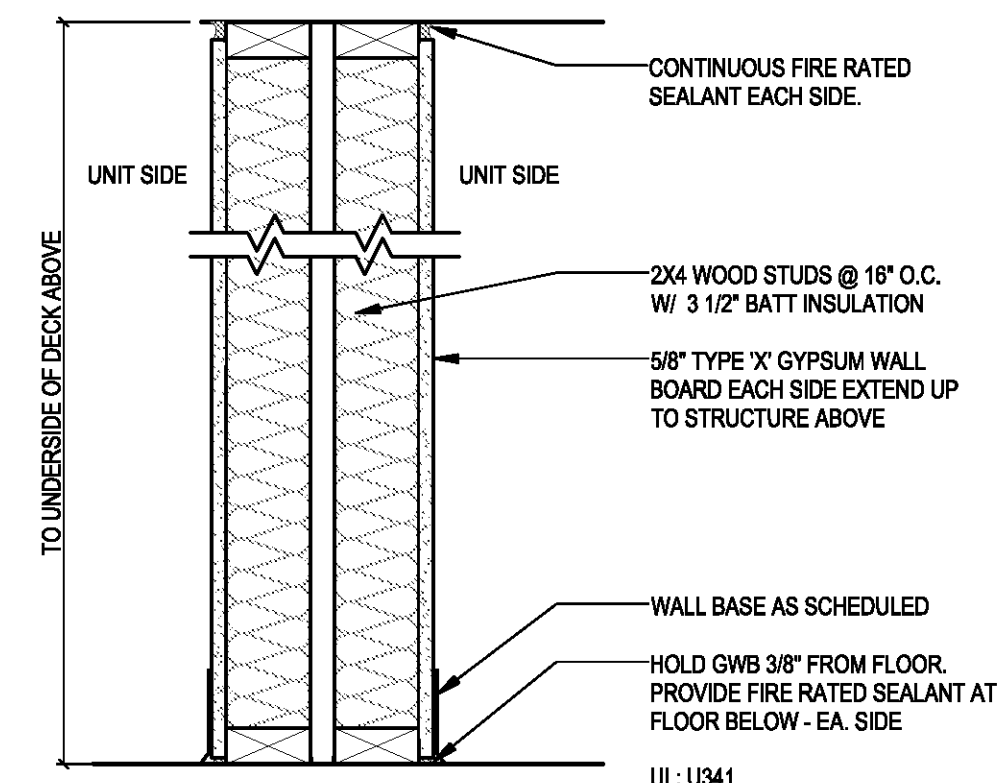

P2 1-HR RATED PARTITION @ BEARING WALL  
1 1/2" = 1'-0" VERIFY LOCATION WITH BUILDING PLANS

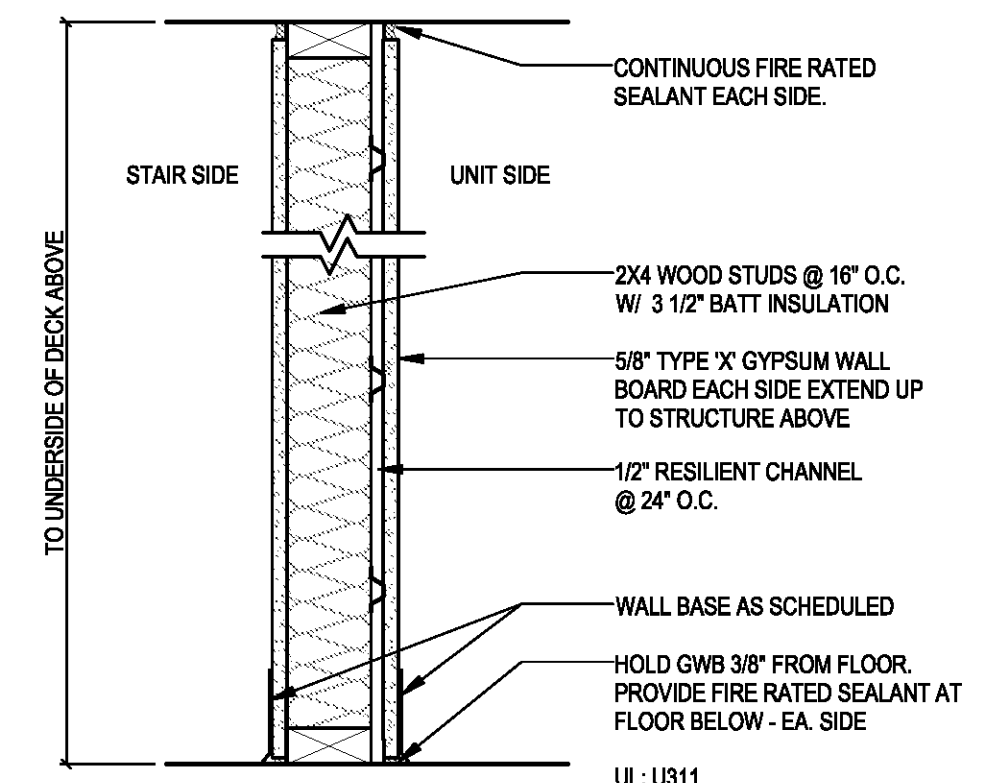

P1 1-HR RATED PARTITION @ STAIR  
1 1/2" = 1'-0" VERIFY LOCATION WITH BUILDING PLANS