

CV/CL SERIES
Cartridge Filters



Jandy[®]
Pro Series
by ZODIAC[®]

CV-CL SERIES
CARTRIDGE FILTER

Crystal Clear Clarity





Jandy Pro Series CV & CL Cartridge Filters

The CV and CL Cartridge Filters set the benchmark in cartridge filtration. Loaded with user-friendly features, Jandy Pro Series Cartridge Filters optimize surface area and help provide clean, sparkling water. They are constructed of durable and corrosion-resistant materials for maximum durability and are available in 340, 460 and 580 square foot models.

- » The included Sweep Elbow and unions allow the filter to easily connect to nearly all Jandy Pro Series products
- » 2" x 2½" Universal Unions and easy grip handles make installation and cleaning easy
- » Extra large 2" drain port allows for easy cleaning
- » Unique pressure gauge features clean/dirty indicator that can be customized, making it easy to assess filter cartridge condition

DIMENSIONS

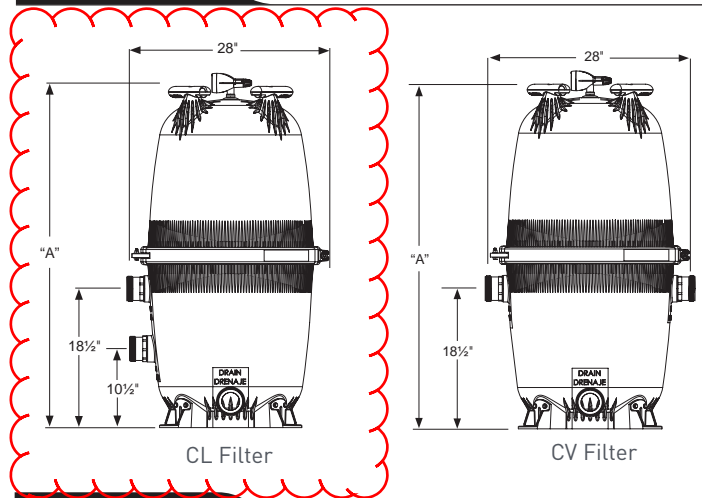

PERFORMANCE

CV/CL Filter Head Loss Curves

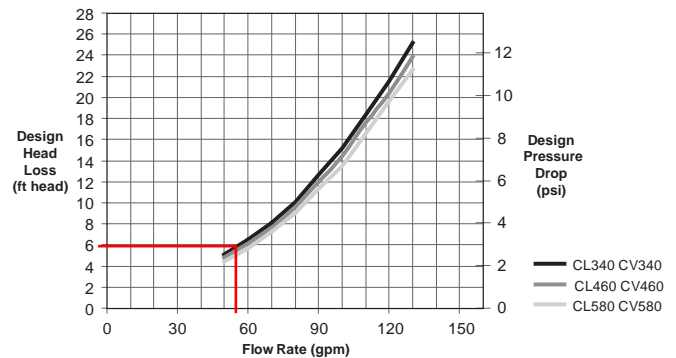

SPECIFICATIONS

Specifications and Dimensions, CL & CV Series Filters

Model Number	CL340	CL460	CL580	CV340	CV460	CV580
Filter Area	340 ft ²	460 ft ²	580 ft ²	340 ft ²	460 ft ²	580 ft ²
Design Flow Rate	.37 gpm/ft ²	.33 gpm/ft ²	.26 gpm/ft ²	.37 gpm/ft ²	.33 gpm/ft ²	.26 gpm/ft ²
Maximum Flow	127 gpm	150 gpm	150 gpm	127 gpm	150 gpm	150 gpm
Six Hour Capacity	45,720 gallons	54,000 gallons	54,000 gallons	45,720 gallons	54,000 gallons	54,000 gallons
Eight Hour Capacity	60,960 gallons	72,000 gallons	72,000 gallons	60,960 gallons	72,000 gallons	72,000 gallons
Maximum Working Pressure	50 psi	50 psi	50 psi	50 psi	50 psi	50 psi
Cartridges Required	4 (85ft ² each)	4 (115ft ² each)	4 (145ft ² each)	4 (85ft ² each)	4 (115ft ² each)	4 (145ft ² each)
Shipping Weight	93 lbs.	95 lbs.	101 lbs.	106 lbs.	106 lbs.	112 lbs.
Height ("A")	41 inches	41 inches	47 inches	41 inches	41 inches	47 inches
Footprint	25" dia. circle	25" dia. circle	25" dia. circle	25" dia. circle	25" dia. circle	25" dia. circle
Distance Between Inlet and Outlet	8"	8"	8"	Not Applicable	Not Applicable	Not Applicable

Zodiac Pool Systems, Inc.
2620 Commerce Way, Vista, CA 92081
1.800.822.7933 | www.ZodiacPoolSystems.com

Zodiac Pool Systems Canada, Inc.
2115 South Service Road West, Unit #3, Oakville, ON L6L 5W2
1.888.647.4004 | www.ZodiacPoolSystems.ca

ZODIAC® FAMILY OF BRANDS | Heritage of Excellence

©2016 Zodiac Pool Systems, Inc. ZODIAC® is a registered trademark of Zodiac International, S.A.S.U., used under license. SL6257 Rev B 0316

SUPERFLO®

HIGH PERFORMANCE PUMP



EFFICIENT, QUIET, RUGGED AND VERSATILE

The SuperFlo pump is a product of more than 40 years of innovative hydraulic engineering. The result is an ability to move more water more efficiently for lower operating cost and super-quiet operation. Plus, by performing with less effort, there's simply less wear and tear—and that means longer life for a higher return on your pump investment.



- With ½ HP–2½ HP and single- and two-speed options, there's a perfect match to your application and assurance of minimum energy consumption.
- Cam and Ramp™ Lid locks in place with a quarter-turn.
- Heavy-duty, high-service-factor, 56-square-flange motor for long life—commercial grade at a consumer price.
- Quiet operation due to superior internal flow design that reduces hydraulic noise.
- See-through lid permits easy inspection of strainer basket.
- The SuperFlo pump is a direct, and superior, replacement for the Hayward® Super Pump®.
- Select pump models are now ENERGY STAR® certified.

Select SuperFlo pumps from Pentair are ENERGY STAR® certified. These pumps meet strict energy-efficiency criteria set by the U.S. Environmental Protection Agency and the U.S. Department of Energy. These pumps save money, reduce energy use and protect the environment.



SUPERFLO[®]

HIGH PERFORMANCE PUMP

When outfitting your new pool or looking for a superior replacement for a Hayward[®] Super Pump[®], the SuperFlo pump drops right into place with ease to minimize installation time and expense

Heavy-duty motor for long service life

Superior hydraulic design and thick-walled body parts deliver super-quiet operation



THE STRONG SILENT TYPE

The SuperFlo pump meets all the criteria for a superior pool, spa or water feature pump. It's super energy efficient, super quiet and super easy to maintain. Plus, it's designed with innovative materials that will stand up to the most demanding installations and conditions. Whether you're choosing your first pump or replacing older technology, the SuperFlo pump is definitely a super choice.

- Self-priming for quicker, easier start-up.
- 115-volt or 230-volt models available.
- Performance and pressure tested to ensure superior quality.
- UL/cUL listed.
- NSF certified.

AVAILABLE FROM:

PERFORMANCE CURVES

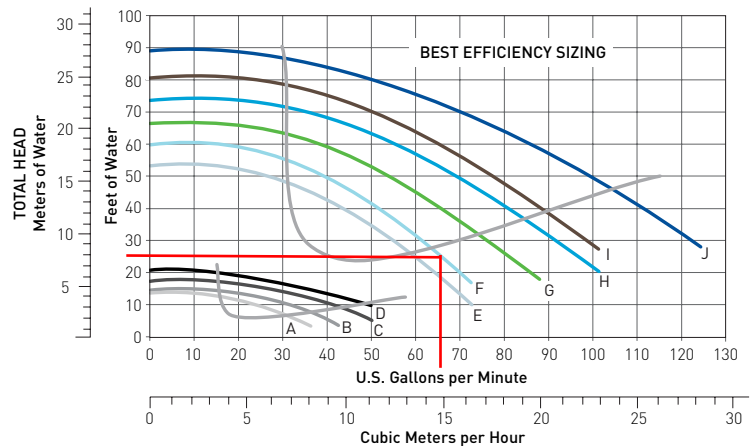

Curve Key	Part Number	HP	Curve Key	Part Number	HP
E	348021	1/2	G	340038	1
F	348022	3/4	H	340039	1-1/2
G	348023	1	I	340040	2
H	348024	1-1/2	J	340041	2-1/2
I	348025	2	A, F	341111	3/4
J	348026	2-1/2	B, G	340042	1
E	340036	1/2	C, H	340043	1-1/2
F	340037	3/4	D, I	340044	2



1620 HAWKINS AVE, SANFORD, NC 27330 800.831.7133 WWW.PENTAIRPOOL.COM

All Pentair trademarks and logos are owned by Pentair or one of its global affiliates. SuperFlo[®] and Cam and Ramp[™] are trademarks and/or registered trademarks of Pentair Water Pool and Spa, Inc. and/or its affiliated companies in the United States and/or other countries. Hayward[®] and Super Pump[®] are registered trademarks of Hayward Industries, Inc. Because we are continuously improving our products and services, Pentair reserves the right to change specifications without prior notice. Pentair is an equal opportunity employer.

pumps • filters • heaters • heat pumps • automation • lighting • cleaners • sanitizers • water features • maintenance products

6/15 Part # P1-232 ©2015 Pentair Water Pool and Spa, Inc. All rights reserved.



F-300

U-300

D-300

Clamp-on Insertion Mount

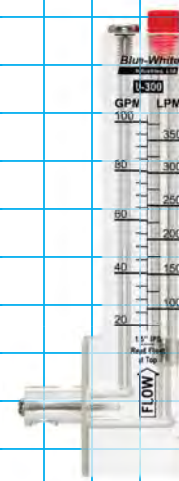

U-300

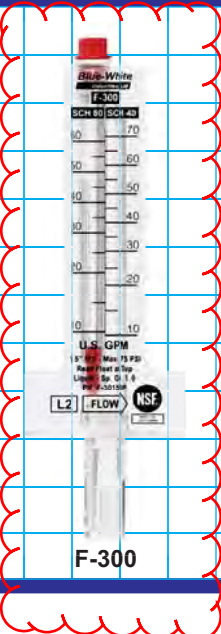

F-300

Features:

- 1" through 8" pipe sizes.
- Flow rates from 4 to 1900 GPM (15 to 7200 LPM).
- Corrosion resistant 316SS, PTFE, or PVDF internal float materials.
- One piece machined acrylic body.
- Mounts to existing pipe. No unions or adapters required.
- Models for mounting on horizontal or vertical pipe.
- Mounting clamps and gasket included.
- NSF Listed (1, 1 1/4", 1 1/2", and 2" horizontal only)

Specifications:

Pipe Requirements: IPS inch pipe size (ASTM-D-1785)
Max. Psi (bar): 75 PSI (5.2 bar) @ 70° F (21° C)
Fluid temp. range: 0° to 190° F / -18° to 88° C @ 0 PSI
Ambient temp. range: 0° to 110° F / -18° to 43° C
Note: Temperature & Pressure ratings of meter only. Actual pipe rating may vary.

Full scale accuracy: 1", 1 1/2", 2", and 3" 5%, all other 10%
Power requirement: No power required
Enclosure: NEMA 4X (IP56)
Approximate shipping wt: 1"-4" units: 1 lb. (.45 kg)
 6"-8" units: 2 lb. (.91 kg)

Materials of Construction:

Meter Body: Cast Acrylic
Float: Standard range models = 316SS or PVDF
 Low range models = PTFE

Gasket: Neoprene
Pipe Clamp: 316 series Stainless Steel
Pitot screw: 300 series stainless Steel (1", 1 1/2", 2", and 3" do not use screw)

Installation Requirements:

Minimum Straight Pipe Length Requirements

The meter's accuracy is affected by disturbances such as pumps, elbows, tees, valves, etc., in the flow stream. Install the meter in a straight run of pipe **as far as possible** from any disturbances.

Example of Minimum Straight Pipe Length Requirements

Nominal Pipe Diameter	Minimum Inlet Pipe Length	Minimum Outlet Pipe Length
4 inch	40 inch (10 X 4")	16 inch (4 X 4")
6 inch	60 inch (10 x 6")	24 inch (4 x 6")

Mounting location

- The meter is designed to withstand outdoor conditions.
- F series meters must be mounted at the vertical (twelve o'clock) position on horizontal pipe only.
- U & D series meters must be mounted on vertical pipe only.
- The pipe must be completely full of water at all times.
- See the minimum straight length of pipe requirement chart above.
- The meter can accurately measure flow from one direction only.
- U-series meters measure upward flows only.
- D-series meters measure downward flows only.

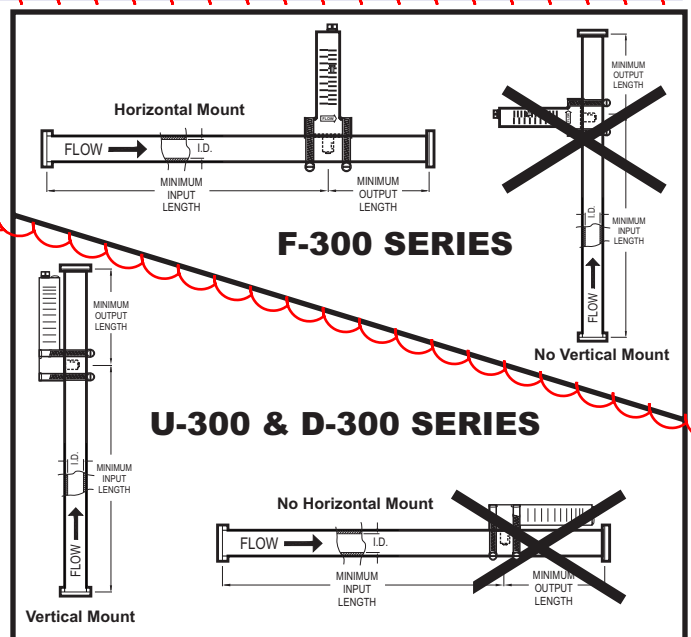

Dimensions:

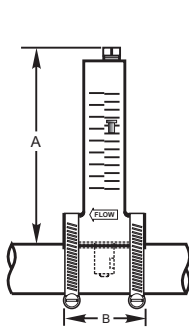

F-300 Series

Pipe Size	A	B
1"	6"	2-7/16"
1-1/4"	6"	2-7/16"
1-1/2"	6"	2-7/16"
2"	6"	2-7/16"
2-1/2"	6"	2-7/16"
3"	6"	2-7/16"
4"	6"	2-7/16"
6"	7-1/2"	2-7/16"
8"	7-1/2"	2-7/16"

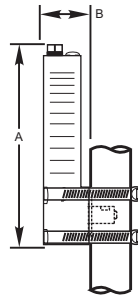

U/D-300 Series

Pipe Size	A	B
1-1/2"	6"	1-9/16"
2"	6"	1-9/16"

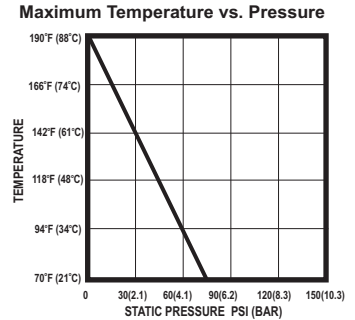

Flow Stream Requirements:

Low viscosity fluids with a specific gravity of 1.0.

Model Number Matrix:

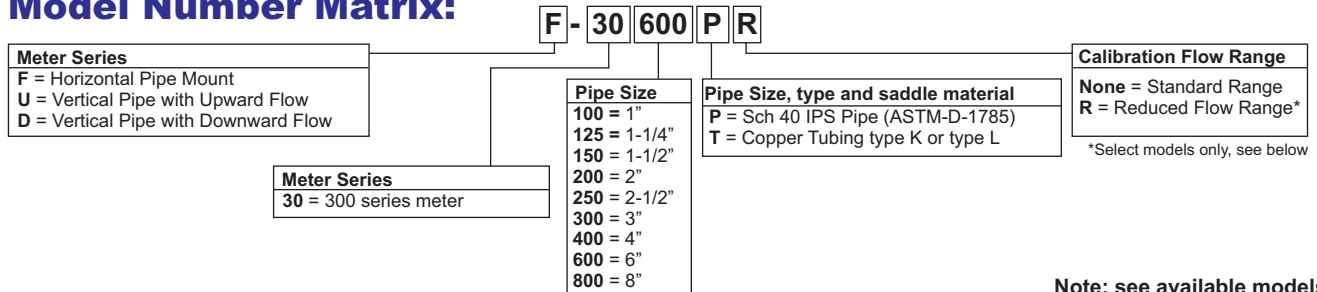

Note: see available models below.

Pipe Size, Flow Range and Display Model Options:

Models for Mounting on Horizontal Pipe

Models for U.S. IPS Sch40 Pipe (ASTM 1785) Display in U.S. Gallons and Liters per Minute

Pipe Size	GPM Flow Range	LPM Flow Range	Model Number
4"	125 to 500	550 to 2000	F-30400P
6"	250 to 1050	900 to 3900	F-30600P
8"	500 to 1900	2000 to 7200	F-30800P

Models for Copper Tubing types K & L Display in U.S. Gallons and Liters per Minute

Pipe Size	GPM Flow Range	LPM Flow Range	Model Number
4"	125 to 500	550 to 2000	F-30400T
6"	250 to 1050	900 to 3900	F-30600T
8"	500 to 1900	2000 to 7200	F-30800T

Models for U.S. IPS Sch40 & 80 Pipe (ASTM 1785) Display in U.S. Gallons per Minute

Pipe Size	Sch40	Sch80	Model Number
1"	5 to 35	4 to 26	F-30100P
1-1/4"	9 to 50	8 to 40	F-30125P
1-1/2"	10 to 70	10 to 60	F-30150P
2"	20 to 120	18 to 100	F-30200P
2-1/2"	29 to 150	25 to 130	F-30250P
3"	45 to 240	40 to 215	F-30300P

Models for Copper Tubing types K & L Display in U.S. Gallons and Liters per Minute

Pipe Size	GPM Flow Range	LPM Flow Range	Model Number
1"	4 to 26	15 to 100	F-30100T
1-1/2"	10 to 65	50 to 250	F-30150T
2"	20 to 105	75 to 400	F-30200T

Models for Mounting on Vertical Pipe

Models for U.S. IPS Sch40 Pipe (ASTM 1785) Display in U.S. Gallons and Liters per Minute

Pipe Size	GPM Flow Range	LPM Flow Range	Flow Direction	Model Number
1-1/2"	20 to 100	75 to 375	UP	U-30150P
1-1/2"	20 to 100	75 to 375	DOWN	D-30150P
1-1/2"	9 to 30	30 to 120	UP	U-30150PR
1-1/2"	9 to 30	30 to 120	DOWN	D-30150PR
2"	40 to 150	150 to 550	UP	U-30200P
2"	40 to 150	150 to 550	DOWN	D-30200P
2"	18 to 70	70 to 280	UP	U-30200PR
2"	18 to 70	70 to 280	DOWN	D-30200PR

Models for Copper Tubing types K & L Display in U.S. Gallons and Liters per Minute

Pipe Size	GPM Flow Range	LPM Flow Range	Flow Direction	Model Number
1-1/2"	20 to 100	75 to 375	UP	U-30150T
1-1/2"	20 to 100	75 to 375	DOWN	D-30150T
1-1/2"	9 to 30	30 to 120	UP	U-30150TR
1-1/2"	9 to 30	30 to 120	DOWN	D-30150TR
2"	40 to 150	150 to 550	UP	U-30200T
2"	40 to 150	150 to 550	DOWN	D-30200T
2"	18 to 70	70 to 280	UP	U-30200TR
2"	18 to 70	70 to 280	DOWN	D-30200TR

Flowmeter Sensor Installation Instructions

F-300S

SKU: 71010-349

New F-300N ships ready to work with optional flow switch / flow rate sensor.



How do you know if your model F-300 is compatible for use with flow sensor?
Simple, if your F-300 has a bright red float, then your meter is compatible with the F-300S flow sensor.

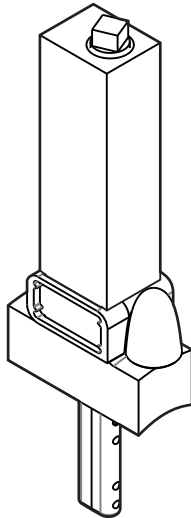

1. Specifications

Voltage	100 VAC or VDC Abs. Max.
Current	0.250 Amp AC/DC Abs. Max.
Power	5 Watts Max.
Contact Configuration	N.O.
Form	A, SPST
Housing Material	PVDF, Black
Lead type	Red & Black, #24 Gage, 5 feet

2. Dimensions

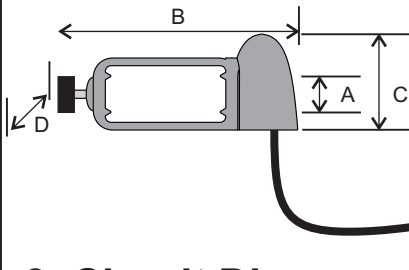

Approx. trigger range:
Contact will trigger (close) when magnetic float present (within range A).

A	0.26" (6.6mm)
B	2.8" (71mm)
C	1.3" (33mm)
D	1.3" (33mm)

3. Circuit Diagram

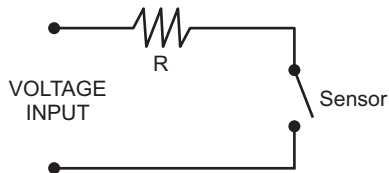

High surge currents may cause damage to the sensor and significantly reduce its life, the following circuit is, therefore, highly recommended.

VOLTAGE @ Max AMP. (V)	Minimum R (OHM) ± 20%
30 DC/AC @ .033 AMP.	1000
24 DC/AC @ .040 AMP.	680
12 DC/AC @ .083 AMP.	150
6 DC/AC @ .166 AMP.	36
4 DC/AC @ .250 AMP.	16

80000-575
12042015

Flowmeter Sensor Installation Instructions

F-300S

SKU: 71010-349

New F-300N ships ready to work with optional flow switch / flow rate sensor.



How do you know if your model F-300 is compatible for use with flow sensor?
Simple, if your F-300 has a bright red float, then your meter is compatible with the F-300S flow sensor.

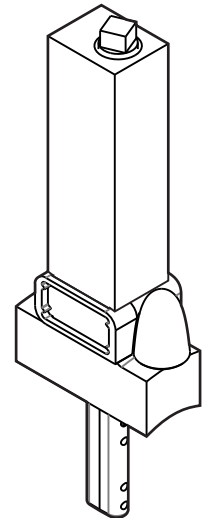

1. Specifications

Voltage	100 VAC or VDC Abs. Max.
Current	0.250 Amp AC/DC Abs. Max.
Power	5 Watts Max.
Contact Configuration	N.O.
Form	A, SPST
Housing Material	PVDF, Black
Lead type	Red & Black, #24 Gage, 5 feet

2. Dimensions

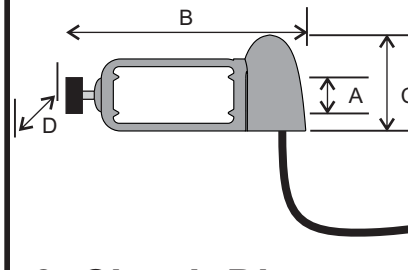

Approx. trigger range:
Contact will trigger (close) when magnetic float present (within range A).

A	0.26" (6.6mm)
B	2.8" (71mm)
C	1.3" (33mm)
D	1.3" (33mm)

3. Circuit Diagram

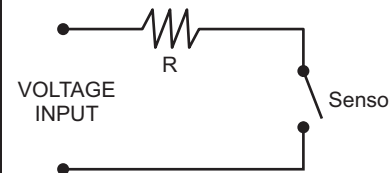

High surge currents may cause damage to the sensor and significantly reduce its life, the following circuit is, therefore, highly recommended.

VOLTAGE @ Max AMP. (V)	Minimum R (OHM) ± 20%
30 DC/AC @ .033 AMP.	1000
24 DC/AC @ .040 AMP.	680
12 DC/AC @ .083 AMP.	150
6 DC/AC @ .166 AMP.	36
4 DC/AC @ .250 AMP.	16

80000-575
12042015

4. Installation

Lock Screw (Thumb Screw) should be loosened (counter clockwise) so the sensor can slide with ease over the top of the F-300 flowmeter. Slide to desired location on flowmeter body. Secure with Lock Screw by tightening (rotate clockwise).

Sensor contact is **closed** when top of float is inside the Alarm Trigger Zone (Hysteresis)

Sensor contact is **open** when top of float is outside of the Alarm Trigger Zone

4.1) Flow Switch: See *Figure 1*

4.1) Flow Rate: See *Figure 2*

Flow Switch *Figure 1*

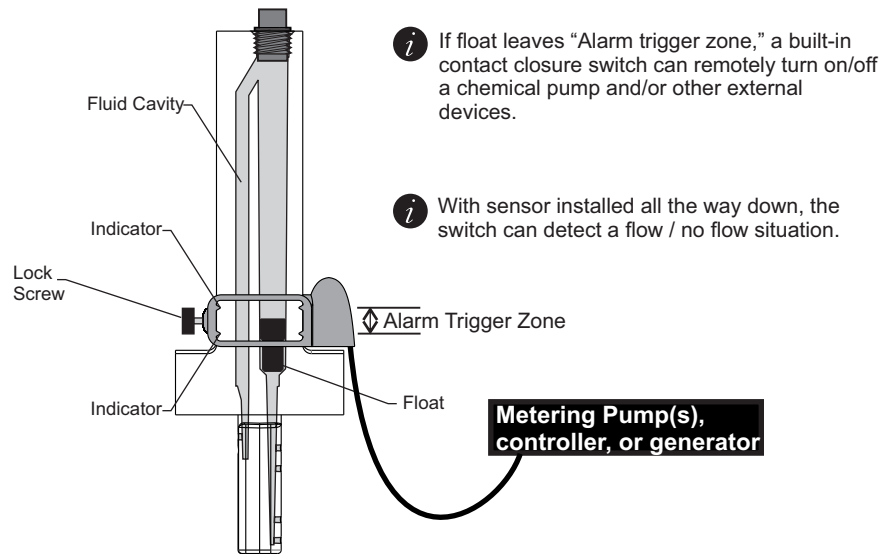

Flow Rate *Figure 2*

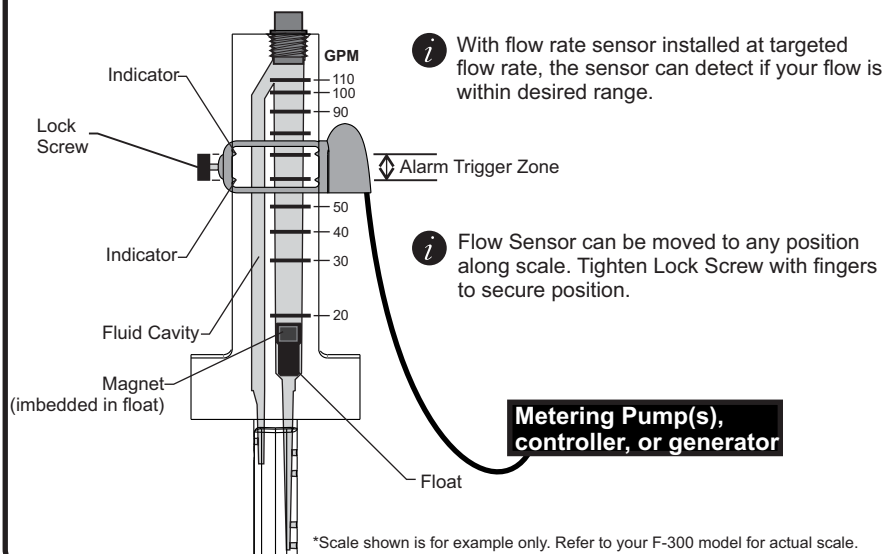

4. Installation

Lock Screw (Thumb Screw) should be loosened (counter clockwise) so the sensor can slide with ease over the top of the F-300 flowmeter. Slide to desired location on flowmeter body. Secure with Lock Screw by tightening (rotate clockwise).

Sensor contact is **closed** when top of float is inside the Alarm Trigger Zone (Hysteresis)

Sensor contact is **open** when top of float is outside of the Alarm Trigger Zone

4.1) Flow Switch: See *Figure 1*

4.1) Flow Rate: See *Figure 2*

Flow Switch *Figure 1*

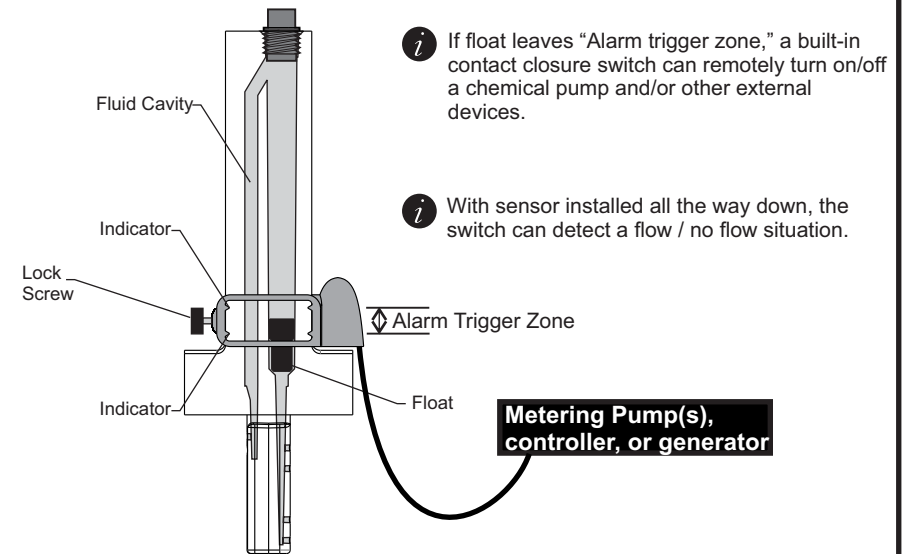

Flow Rate *Figure 2*

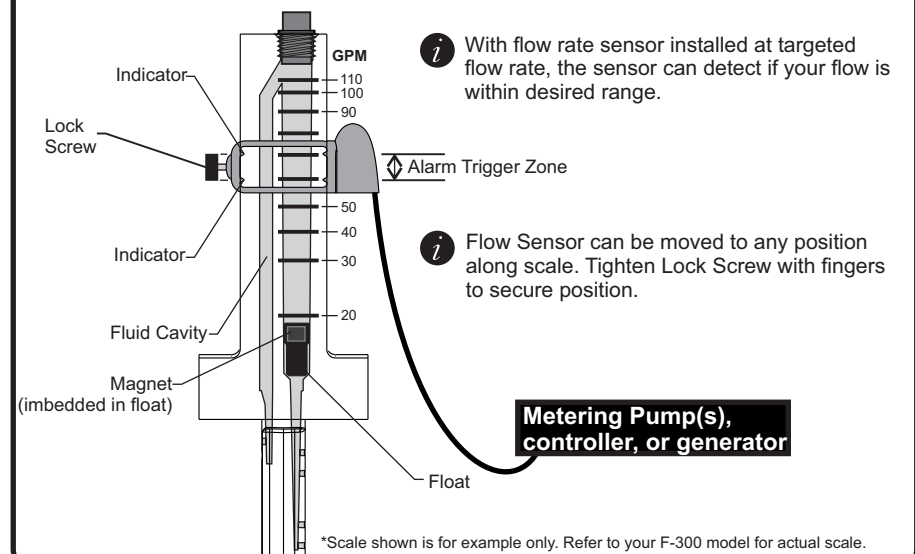

RAINBOW™ MODEL 300/320

AUTOMATIC CHLORINE/BROMINE FEEDERS

THE EFFICIENT, EASY WAY TO SANITIZE YOUR POOL OR SPA

The Rainbow Models 300 and 320 feeders not only save time but also reduce manual handling of chemicals. They use large or small trichlor or bromine slow-dissolving tablets to make sanitizing your new or existing pool or spa easy and automatic. Both install easily on the pressure side of the pump, downstream of the filter and heater.



The freestanding Model 300 feeder and the in-line Model 320 feeder both feature an external fine-control valve that lets you adjust the feed rate to meet specific pool or spa requirements. The Model 300 feeder is ideal for retrofitting existing pools for automatic sanitization. The Model 320 feeder is designed for permanent installation in the return line of new or existing systems and dispenses sanitizer directly into your pool or spa, downstream of all equipment.

- Completely enclosed systems—no escaping fumes.
- Simple, trouble-free designs—no special venting required.
- Top loading makes it easy to add chemicals. Also available in clear amber for easy tablet viewing.

The feeder extensions increase tablet or stick capacity, so you can vacation without worrying about running out of chlorine.



RAINBOW™ MODEL 300/320

AUTOMATIC CHLORINE/BROMINE FEEDERS

Check valve protects pump and heater from back-up of highly chlorinated water

Flow indicator allows a quick visual read of water flow



SAVE TIME, REDUCE MANUAL HANDLING OF CHEMICALS

Whether you choose the freestanding Model 300 feeder or the in-line Model 320 feeder, Rainbow feeders will take the work and worry out of keeping your pool sparkling clean and ready to use.

MODEL 300 FEEDER

Chamber Capacity	Quantity	Weight
1" Tablet	.98	3.5 lbs.
3" Tablet	.11	4.8 lbs.
Maximum Erosion in 24 Hours		1.19 lbs.
Treats Pool/Spa Size in Gallons per 24 Hours*		
@ 10 ppm		11,900
@ 5 ppm		23,800
@ 2½ ppm		47,600
Dimensions		21"H x 7"W x 12"D
Service Clearance for Lid Removal		22¼"

*Using 1" trichlor tabs.

MODEL 320 FEEDER

Chamber Capacity—1" Tablet	Bottom Feed	Top Feed
Quantity	.98	.98
Weight	3.5 lbs.	3.5 lbs.
Chamber Capacity—3" Tablet		
Quantity	.11	.11
Weight	4.8 lbs.	4.8 lbs.
Maximum Erosion in 24 Hours	0.67 lbs.	1.75 lbs.
Treats Pool/Spa Size in Gallons per 24 Hours*		
@ 10 ppm	6,700	17,500
@ 5 ppm	13,400	35,000
@ 2½ ppm	26,800	70,000
Dimensions	17¾"H x 5"W x 10"D	17¾"H x 5"W x 10"D
Service Clearance for Lid Removal	19"	19"

*Using 1" trichlor tabs.

AVAILABLE FROM:

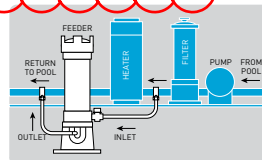

Illustration of Model 300 Feeder

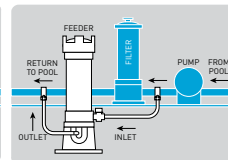

Illustration of Model 320 Feeder



1620 HAWKINS AVE, SANFORD, NC 27330 800.831.7133 WWW.PENTAIRPOOL.COM

All Pentair trademarks and logos are owned by Pentair or one of its global affiliates. Rainbow™ is a trademark of Pentair Water Pool and Spa, Inc. and/or its affiliated companies in the United States and/or other countries. Because we are continuously improving our products and services, Pentair reserves the right to change specifications without prior notice. Pentair is an equal opportunity employer.

pumps • filters • heaters • heat pumps • automation • lighting • cleaners • sanitizers • water features • maintenance products

8/15 Part # R5-1015 ©2015 Pentair Water Pool and Spa, Inc. All rights reserved.



Output rating for Bromine is not NSF Certified

NSF listed for public or residential use in swimming pools, spas or hot tubs using 1" trichlor tablets and when used with a flow-indicating device, such as Rainbow Model #R172080.

6" ROUND HOCKEY PUCK SUMPLESS SUCTION OUTLET COVER, HYDROAIR/ITT REPLACEMENT

VGB Series

The AquaStar line of suction outlet covers, compliant with the Virginia Graeme-Baker Pool and Spa Safety Act (ANSI/APSP 16-2011 and NSF/ANSI 50-2009a) ←

FEATURES

For single or multiple drain use in gunite, steel, fiberglass and tile pools and spas (see installation instructions)

Single – sumpless

Floor/wall (2" pipe): 224 GPM at 6.3 fps

Floor (1½" pipe): 177 GPM at 5.9 fps

Wall (1½" pipe): 122 GPM at 3.4 fps

Floor/wall: 53.3 GPM at 1.5 fps

Floor/wall: 35.5 GPM at 1.0 fps

10.4 square inch opening

Trademarked VGB compliance button easily identifies VGB 2008 compliant cover from on deck and underwater

#316 stainless steel screws

Manufactured from superior UV-resistant engineered polymers

All components meet or exceed ANSI/APSP 16-2011 and NSF/ANSI 50-2009a national standards and ASTM G154 UV testing exposure

See next page for eight adapter plates sold separately, available for sumpless connections to 1022s, 1.5" female adapters, 1.5" and 2" inside and outside slip and threads as well as existing HydroAir wall fittings #10-6015S and 10-6304S (both with brass inserts)

Replace every five years from the date of installation

25 per case

No sump required!



Part # 6HPxxx

STANDARD COLORS

6HPHA101 – White

6HPHA102 – Black

6HPHA103 – Light Gray

6HPHA104 – Blue

6HPHA105 – Dark Gray

6HPHA108 – Tan

Can replace MaxFlow covers used with p/n 6HA25T20Sxxx

VGB 2008 Compliant

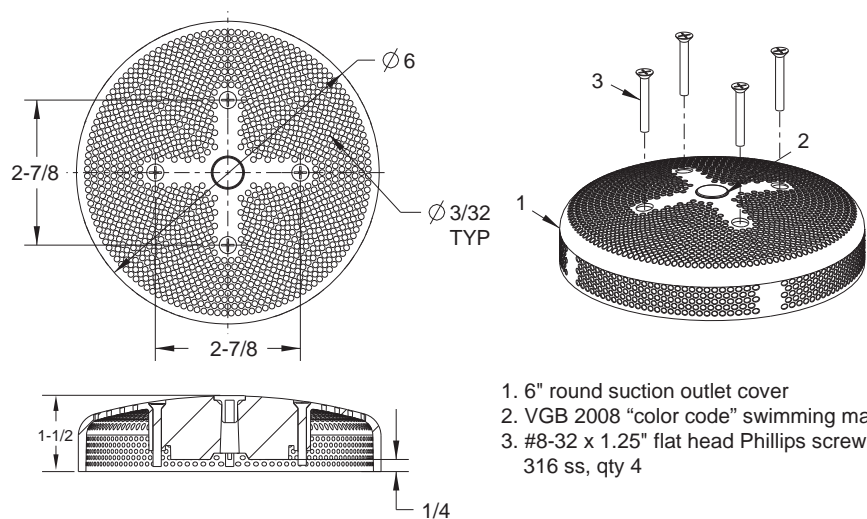

1. 6" round suction outlet cover
2. VGB 2008 "color code" swimming man
3. #8-32 x 1.25" flat head Phillips screw, 316 ss, qty 4

Retrofits to Sta-Rite/Pentair #8011 and AquaStar #4RNDxxx equalizer



VGB SERIES

SUBMERGED, MULTIPLE AND SINGLE SUCTION OUTLET INSTRUCTIONS

IMPORTANT SAFETY INSTRUCTIONS FOR MODELS:

10AVRxxx, 10AVxxx, SUN18HPHxxx, WAV24xxx, 24xxx, 1216xxx, 914xxx, A8Rxxx, 8AVxxx, LP8AVxxx, RFS9xxx, RFS12xxx, P9xxx, P12xxx, P18xxx, P24xxx, WAV9xxx, WAV12xxx, WAV18xxx, A10RCFRxxx, 8FUWxxx, 10LTxxx, 10LTDxxx, 6PHPAxxx, 4HPxxx, 8MFxxx, R8MFxxx, 10MFxxx, 9MFxxx, R9MFxxx, 12MFxxx, R12MFxxx, 18MFxxx, R18MFNFxxx, A10RCFRxxx-V

(xxx = COLOR SUFFIX)

MEETS OR EXCEEDS ANSI/APSP 16-2011

ANTI-ENTRAPMENT/ANTI-VORTEX



READ AND FOLLOW ALL INSTRUCTIONS



▲ WARNING!

IMPROPER INSTALLATION OR USE OF THIS PRODUCT MAY PRESENT A RISK OF HAIR OR BODY ENTRAPMENT AND DROWNING. Install this equipment in accordance with the instructions provided. Use only with the components and mounting hardware provided. FAILURE TO FOLLOW THESE INSTRUCTIONS AND/OR USE WITH COMPONENTS NOT PROVIDED BY AQUASTAR POOL PRODUCTS AND INTENDED TO BE USED WITH THIS PRODUCT MAY RESULT IN IMPROPER POSITIONING OR FUNCTIONING OF SUCTION OUTLET AND MAY CAUSE SEVERE PERSONAL INJURY OR DEATH.

SAVE THESE INSTRUCTIONS FOR FUTURE REFERENCE

- If not a single, unblockable outlet, in the event of one suction outlet being completely blocked, the remaining suction outlets serving the system shall have a flow rating capable of the full flow of the pump(s) or the specific suction system. If in doubt about the rating and/or head loss curve of your system, consult a qualified pool or spa professional and/or your respective equipment manufacturer(s). Also, double-check with your local building/health authorities regarding single vs. multiple drain installations, etc.
- All sizes of connecting pipe are acceptable, pending velocity and GPM calculations. The larger, the better! DO NOT exceed maximum flow rate(s) of cover or pipe(s) flow rate(s), whichever is less.
- Replace cover and screws within five years.

SPECIAL NOTES:

- Pool finish should never exceed top of frame.
- Taper pool finish down and away from top (or lower) of frame.
- Top of grate should never be installed lower than the pool finish.
- Take special notice when retrofitting into an existing frame where possible existing multiple layers of re-plastering have created a concave situation, either chip or grind down old surface or install new frame at higher level. Use of bushing kit may also be required to achieve proper elevation.

MAXIMUM RECOMMENDED SYSTEM FLOW RATE BY PIPE SIZE

Pipe size	1½"	2"	2½"	3"
Flow rate in GPM	45	80	110	160

ALL MODELS LISTED BELOW = ANTI-ENTRAPMENT/ANTI-VORTEX AND FOR SINGLE OR MULTIPLE USE

MAX FLOW RATES (PER OUTLET) MOUNTING POSITIONS (xxx=COLOR SUFFIX)												
Model	WAV24xxx	24xxx	1216xxx (and R1216xxx)	914xxx (and R914xxx)	SUN18HPHxxx (min 6" pipe size)	10AVRxxx (with solid riser ring) (min 2" pipe size)	A8Rxxx (with solid riser ring) (min 2" pipe size)	10LTxxx (min. 2" pipe size)	10LTDxxx (min. 2" pipe size)	8AVxxx, RFS9xxx (with vented riser ring)	10MFxxx (min 2" pipe size)	8MFxxx (min 2" pipe size)
Floor	1444 GPM @ 1.3 fps	1531 GPM @ 1.4 fps	460 GPM @ 1.46 fps	560 GPM @ 2.1 fps	1000 GPM @ 3.1 fps	166 GPM @ 4.8 fps	145 GPM – 3" sump 140 GPM – sumpless @ 2.9 fps	60 GPM @ .7 fps	125 GPM @ 1.4 fps	88 GPM @ 2.0 fps	158 GPM @ 1.6 fps	166 GPM @ 3.2 fps
Wall	1444 GPM @ 1.3 fps	1531 GPM @ 1.4 fps	445 GPM @ 1.4 fps	300 GPM @ 1.2 fps	644 GPM @ 2.0 fps	96 GPM @ 2.8 fps	84 GPM @ 1.7 fps	NA	NA	70 GPM @ 1.6 fps	162 GPM @ 1.7 fps	113 GPM @ 2.2 fps
Model	WAV18xxx (with vented riser ring)	WAV12xxx (with vented riser ring)	WAV9xxx (with vented riser ring)	P9xxx (with vented riser ring)	P12xxx (with vented riser ring)	10AVxxx (with vented riser ring)	8FUWxxx (min 2" pipe size)	P18xxx (with vented riser ring)	P24xxx	A10RCFRxxx, A10RCFRxxx-V (min 2" pipe size) (sumpless)	R8MFxxx (min 2" pipe size)	9MFxxx (min 2½" pipe size)
Floor	628 GPM @ 1.1 fps	361 GPM @ 1.3 fps	224 GPM @ 1.5 fps	270 GPM @ 2.1 fps	360 GPM @ 1.5 fps	206 GPM @ 4.1 fps	110 GPM @ 2.2 fps	740 GPM @ 1.5 fps	1428 GPM @ 1.5 fps	170 GPM @ 1.7 fps	146 GPM @ 2.9 fps	258 GPM @ 2.3 fps
Wall	628 GPM @ 1.1 fps	361 GPM @ 1.3 fps	224 GPM @ 1.5 fps	270 GPM @ 2.1 fps	360 GPM @ 1.5 fps	96 GPM @ 1.9 fps	106 GPM @ 2.1 fps	740 GPM @ 1.5 fps	1428 GPM @ 1.5 fps	170 GPM @ 1.7 fps	130 GPM @ 2.6 fps	274 GPM @ 2.4 fps
Model	R9MFxxx (min 2½" pipe size)		12MFxxx (min 2½" pipe size)		R12MFxxx (min 2½" pipe size)		18MFxxx, R18MFNFxxx (min 3" pipe size)					
Floor	258 GPM @ 2.3 fps		274 GPM @ 1.2 fps		274 GPM @ 1.3 fps		293 GPM @ .6 fps					
Wall	274 GPM @ 2.5 fps		278 GPM @ 1.3 fps		278 GPM @ 1.3 fps		NA					

INSTALLATION LAYOUTS

- A. Requires Phillips screw driver. Hand tighten only. Do not use electrical or air drills.
- B. See Fig. 1 for installation layout with manufactured sump
- C. See Fig. 2 for installation layout without manufactured sump (field-fabricated sump)
- D. Measure from underside of high point of the cover to the top of pipe(s) to determine proper sump depth.
- E. Top of all suction outlets shall not exceed 2" above pool floor or wall.

MANUFACTURED SUMP INSTALLATION (DUAL PORT)

IMPORTANT

- Single or multiple drain use
- Models: SB, DD (A), or DDSB (B) (SB = Std Sump Bucket, DD (A) = Deep Sump/Frame, DDSB (B)= Deep Sump Bucket) with 10AVRxxx, 10AVxxx, 10LTxxx, 10LTDxxx, 8AVxxx, LP8AVxxx, WAV9xxx, WAV12xxx, SUN9xxx, SUN12xxx, 1216xxx, 914xxx, A8Rxxx, 8FUWxxx, P9xxx, P12xxx, 8MFxxx, 9MFxxx, 10MFxxx, 12MFxxx, 18MFxxx
- NOTE: 8" round SB available in three styles: (6" deep)
 - Regular collar (frame) with side/bottom ports
 - Adjustable collar (frame) (AC) with side/bottom ports
 - Vinyl/fiberglass (V) with side/bottom ports
- NOTE: 9" and 12" square and 10" round DDSB (B, D, F) available in three styles: (12" deep)
 - Regular collar (frame) with two 2½" and 2" ports on bottom only (no side port) (B)
 - Regular collar (frame) with one 4" port on bottom only (no side port) (D)
 - Regular collar (frame) with one 6" port on bottom only (no side port) (F)

fig. 1

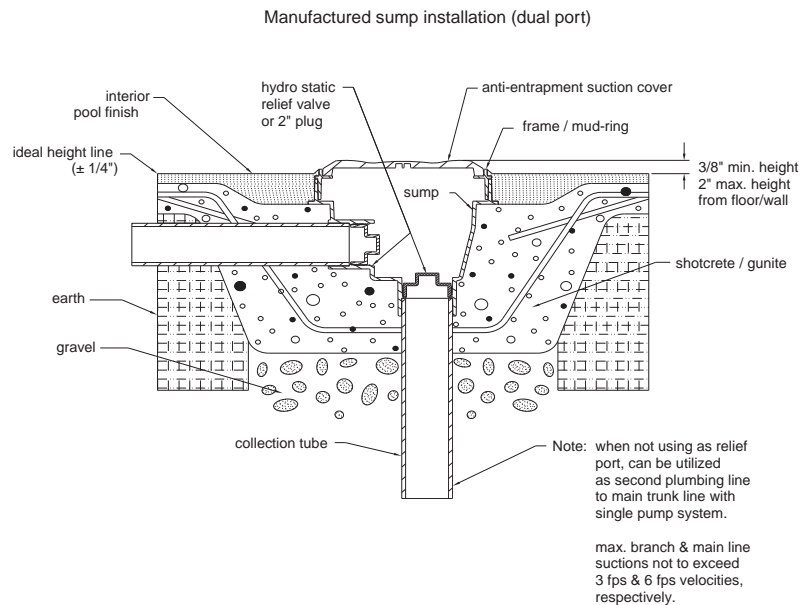

FIELD FABRICATED SUMP INSTALLATION (SINGLE OR DUAL PORT)

IMPORTANT

- At IAPMO and UL (nationally recognized labs), all AquaStar suction outlet covers have been tested with 3" deep sumps (unless otherwise indicated)
- A and/or B should be a min. 3" to bottom of cover. (except: SUN18HPHxxx, WAV18xxx, P18xxx, 18MFxxx – 6", WAV24xxx, P24xxx and 24xxx – 12", A8Rxxx at 140 GPM – floor / 84 GPM – wall, A10RCFRxxx – sumpless)
- Second line can be on bottom area
- Single or multiple drain use
- Models: 10AVRxxx, 10AVxxx, 8AVxxx, LP8AVxxx, WAV9xxx, WAV12xxx, P9xxx, P12xxx, P18xxx, P24xxx, WAV24xxx, 24xxx, RFS9xxx, RFS12xxx, WAV18xxx, 1216xxx, 914xxx, A8Rxxx, SUN18HPHxxx, A10RCFRxxx, 8FUWxxx, 10LTxxx, 10LTDxxx, 8MFxxx, R8MFxxx, 9MFxxx, R9MFxxx, 10MFxxx, 12MFxxx, R12MFxxx, 18MFxxx

fig. 2

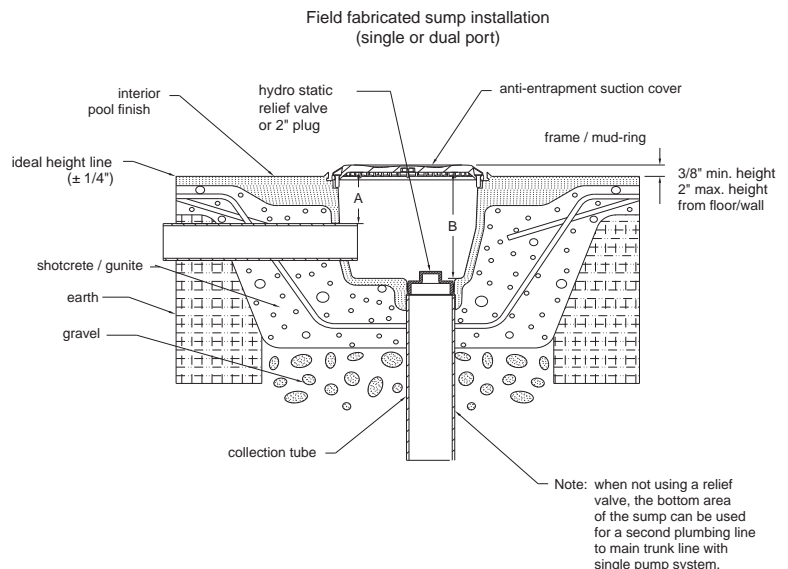

For additional information on proper drain installation refer to The Association of Pool & Spa Professionals ANSI/APSP-7 Standard and the U.S. Consumer Product Safety Commission Guidelines for Entrapment Hazard.

▲ WARNING! SUCTION ENTRAPMENT HAZARD

INCREASING PUMP SIZE WILL INCREASE FLOW. When in doubt, consult your pool and spa professional. NEVER use a pool or spa that has a missing or broken suction outlet cover. USING A POOL OR SPA WITH A MISSING OR BROKEN SUCTION OUTLET COVER CAN RESULT IN HAIR OR BODY ENTRAPMENT WHICH CAN CAUSE SEVERE BODILY INJURY OR DEATH. THE VACUUM IN SUCTION OUTLETS AND/OR SUCTION OUTLET COVERS WHICH ARE DAMAGED, BROKEN, CRACKED, MISSING OR UNSECURED CAN CAUSE SEVERE INJURY AND/OR DEATH DUE TO THE FOLLOWING ENTRAPMENT HAZARDS: HAIR ENTRAPMENT – Hair can become entangled in suction outlet cover. LIMB ENTRAPMENT – A limb inserted into an opening of a suction outlet sump or suction outlet cover that is damaged, broken, cracked, missing or not securely attached can result in a mechanical bind or swelling of the limb. BODY SUCTION ENTRAPMENT – A negative pressure applied to a large portion of the body or limbs can result in an entrapment. EVISCERATION/DISEMBOWELMENT ENTRAPMENT – A negative pressure applied directly to the intestines through an unprotected suction outlet sump or suction outlet cover which is damaged, broken, cracked, missing, or unsecured can result in evisceration/disembowelment entrapment. MECHANICAL ENTRAPMENT – There is a potential for jewelry, swimsuit, hair decorations, finger, toe or knuckle to be caught in an opening of a suction outlet cover resulting in mechanical entrapment. AFTER INSTALLATION OF FITTINGS, IF A GAP EXISTS BETWEEN POOL FINISH AND BASE OF COVER IT MUST BE FILLED IN WITH A TWO-PART EPOXY TO AVOID FINGER OR OTHER ENTRAPMENT.

▲ WARNING! TO REDUCE THE RISK OF ENTRAPMENT HAZARDS

If not an approved single, unblockable outlet, a minimum of two functioning suction outlets per pump must be installed. Suction outlets in the same plane (i.e. floor or wall) must be installed a minimum of three feet (3') (1 meter) apart, as measured from center point to center point. Dual suction fittings shall not be located on seating areas or on the backrest for such seating areas. If any suction outlets are located closer they shall be located on two different planes (i.e. one on the bottom and one on the vertical wall, or one each on two separate vertical walls). The maximum system flow rate shall not exceed the flow rating of any listed (per ANSI/APSP 16-2011) suction outlet cover installed. Never use pool or spa if any suction outlet component is damaged, broken, cracked, missing or not securely attached. Replace damaged, broken, cracked, missing or not securely attached suction outlet components immediately. In addition to two or more suction outlets per pump installed in accordance with latest APSP, IAF Standards and CPSC guidelines, follow all national, state and local codes applicable. Use only transitional (typically green) glues when attaching PVC pipe to ABS fittings. Use gray medium set glue when attaching PVC pipe to our PVC based skimmers and double deep sump buckets. In both cases, do not ever use blue glue or related hot glues, clear glues or any fast setting cement.

WARNING! – Failure to remove pressure test plugs and/or plugs used in winterization of the pool/spa from the suction outlets can result in an increased potential for suction entrapment as described above.

WARNING! – Failure to keep suction outlet components clear of debris, such as leaves, dirt, hair, paper and other material can result in an increased potential for suction entrapment as described above.

WARNING! – Suction outlet components have a finite life, the cover/grate should be inspected before each use of facility and replaced at least every five years or if found to be damaged, broken, cracked, missing, not securely attached or missing screws. **DO NOT** use facility until corrected!

As the manufacturer, AquaStar Pool Products, Inc., hereby certifies that their suction outlet and drain covers meet or exceed the requirements of the Virginia Graeme Baker Pool & Spa Safety Act, VGB 2008 and ANSI/APSP 16-2011 standards and safety regulations as set forth by the Consumer Products Safety Commission. A copy of this certificate of compliance is available on AquaStar Pool Products Inc.'s website under news & information: www.aquastarpoolproducts.com

A Safe Drain is No Accident™





SUMPLESS, BULKHEAD POOL & SPA SUBMERGED SUCTION OUTLET INSTRUCTIONS

VGB SERIES

IMPORTANT ADDITIONAL SAFETY INSTRUCTIONS FOR
4HPxxx and 6HPHAxxx
(xxx = COLOR SUFFIX)



READ AND FOLLOW ALL FOUR PAGES OF INSTRUCTIONS



MEETS OR EXCEEDS ANSI/APSP 16-2011
ANTI-ENTRAPMENT/ANTI-VORTEX

MAX FLOW RATES (PER OUTLET) MOUNTING POSITIONS (xxx=COLOR SUFFIX)					
Model	4HPxxx	4HP TOTAL OPEN AREA	6HPHAxxx (2")	6HPHAxxx (1½")	6HPHA total open area
Floor	N/A	N/A	224 GPM @ 6.3 fps	177 GPM @ 5.9 fps	10.4 sq. in.
Wall	56 GPM @ 3.5 fps	5.2 sq. in.	224 GPM @ 6.3 fps	122 GPM @ 3.4 fps	10.4 sq. in.

SPECIAL NOTES FOR HP FITTINGS

- 6HPHA max flow is 224 GPM allowed for both floor and wall with 2" or greater pipe sizes.
- When 1.5" pipe size is used, max flow rate allowed for the 6HPHAxxx is 177 GPM and 122 GPM for floor and wall respectively.
- 4HP max flow is 56 GPM allowed only for wall applications.
- No sump is required. AquaStar's Sumpless Series is designed and tested for safe flush-mount installations to tile, fiberglass, acrylic, vinyl and steel as well as plaster, pebble, concrete, etc.
- ABS bulkhead adapter fitting must be securely attached to plumbing with proper glue. Use ABS to PVC transitional glues (such as Oatey® Weld-on® and other green NSF glues).
- **DO NOT** use clear, "hot", "blue" or any fast set glues with any AquaStar pool products.
- When retro-fitting, extra secure installations can be obtained by applying wet and dry epoxy, silicone, etc., to underside of base plates.
- After installation of bulkhead adapter fittings, if a gap exists between pool finish and base of cover it must be filled in with a two-part epoxy to avoid finger or other entrapment.

Hand & Stair Rails

DMS-102

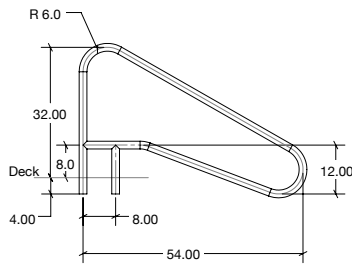

- Tubing: 1.90" OD
- Wall Thickness*: .049" or .065"
- Stainless Steel: 304 or 316L Marine Grade** (add -MG to part number)
- Bends: 6" Radius
- Options: Powder-coating and SealedSteel Salt Friendly
- Recommended Anchors: AS-I00P or AS-I00B (order separately)
- Recommended Escutcheon: EP-I00F (order separately)
- **Sold as a single rail**

* Minimum rail thickness is .065 for Commercial

** Minimum requirement for salt pools is 316L Marine Grade

DMS-102

Model No.	Description	Shipping			
		Weight	Length	Width	Height
DMS-102A	54" Center Grab Rail, .049"	15 lbs — 19 lbs 7 — 9kg	59" 150cm	39" 99cm	2" 5cm
DMS-102B	54" Center Grab Rail, .065"	15 lbs — 19 lbs 7 — 9kg	59" 150cm	39" 99cm	2" 5cm
DMS-102P	54" Center Grab Rail, .049" w/welded mounting plate	15 lbs — 19 lbs 7 — 9kg	59" 150cm	39" 99cm	2" 5cm.

Taylor's FAS-DPD Drop Test Kits

INTRODUCTION

In recent years, professionals in the pool and spa industry have progressed from using orthotolidine (OT) to N,N-diethyl-p-phenylene-diamine (DPD) when determining chlorine levels with color-matching tests.

The OT method only measures total chlorine—the sum of active and spent sanitizer—which makes maintaining the correct residual a guessing game. Because of this, **regulatory authorities do not permit OT testing in commercial pools.** In addition, orthotolidine contains hydrochloric acid, making it more costly to ship than DPD and therefore more costly to buy.

Unlike OT, the DPD method will distinguish between free available chlorine and total chlorine. By subtracting the free chlorine reading from the total chlorine reading, the amount of combined chlorine in the water can be known. Combined chlorine is not an effective sanitizer. Its presence causes eye and mucous membrane irritation and the characteristic “chlorine” odor of a poorly maintained pool.

Combined chlorine is eliminated by superchlorination. Calculations for the breakpoint dosage depend on knowing the level of combined chlorine in the water, which is why the DPD method is superior to the OT method for testing chlorine-sanitized pools. However, bromine is an effective sanitizer in all its forms. Because of this, either OT or DPD may be used to test bromine pools and spas.

The latest trend in commercial pools with chlorine sanitizer has been the FAS-DPD titration method, which can measure **free and combined chlorine as low as 0.2 ppm** (using a 25 mL sample size) **and as high as 20 ppm** (using a 10 mL sample size).

To get the free chlorine reading, a buffered DPD indicator powder is added to the water sample. It reacts with the chlorine to produce the pink color characteristic of the standard DPD test. Ferrous ammonium sulfate (FAS) titrating reagent is then added until the pink color permanently disappears, signaling the endpoint.

The distinct change from a vibrant pink to no color at all eliminates the need for color matching. This feature comes in handy when testing samples with high levels of sanitizer because the user does not have to distinguish between relatively close printed-color gradations. This test is also a boon for colorblind users.



Kits with FAS-DPD measure free and combined chlorine precisely without color matching (K-2006 shown). Watch a video demonstration on our website.

The second half of the FAS-DPD test determines the amount of combined chlorine present. It too involves turning the sample from a vibrant pink to a colorless endpoint.

FAS-DPD is available in stand-alone kits to measure chlorine or bromine, and in combination with other common tests.

FAS-DPD TEST KITS

K-1515-A

Drop test measuring free & combined chlorine;
1 drop = 0.2 or 0.5 ppm; .75 oz. bottles

K-1515-C

Same as above but with 2 oz. bottles

K-1517-A

Drop test measuring total bromine;
1 drop = 0.5 or 1.25 ppm; .75 oz. bottles

K-1517-C

Same as above but with 2 oz. bottles

K-1518

Drop test measuring free & combined chlorine accurately in the presence of monopersulfate shocks; 1 drop = 0.2 ppm chlorine/1 drop = 0.2 ppm monopersulfate as chlorine;
2 oz. bottles



the most trusted name in water testing

Taylor Technologies, Inc.
410-472-4340
800-TEST KIT (837-8548)
www.taylortechnologies.com

ISO 9001:2008 Certified

FAS-DPD TEST KITS (cont'd)

K-2006 (Spanish: K-2006S)

Complete™: free & combined chlorine 1 drop = 0.2 or 0.5 ppm; pH (with acid & base demand); total alkalinity; calcium hardness; cyanuric acid; .75 oz. bottles

Quantity price breaks available when purchasing 6 or more

K-2006-SALT

Complete™: Same as K-2006 plus a test for sodium chloride

K-2006C

Service Complete™: Same as K-2006 but with 2 oz. bottles

Quantity price breaks available when purchasing 8 or more

K-2006C-SALT

Service Complete™: Same as K-2006C plus a test for sodium chloride

Quantity price breaks available when purchasing 8 or more

K-2106

Complete™: total bromine 1 drop = 0.5 or 1.25 ppm; pH (with acid & base demand); total alkalinity; calcium hardness; .75 oz. bottles

Quantity price breaks available when purchasing 6 or more

K-2009

Pool Inspector™: free & combined chlorine 1 drop = 0.2 or 0.5 ppm; pH; cyanuric acid (contains 6 bottles of CYA reagent, 4 more than the K-2006); .75 oz. bottles

Quantity price breaks available when purchasing 6 or more

USER BENEFITS

- Titrations do not require the ability to match colors, only the ability to see the **permanent color change** at the end-point of the reaction.
- Test kits **come complete** with all necessary reagents and equipment.
- **Waterproof instructions** are printed on plastic-impregnated paper that resists fading and tearing.
- Custom-molded, durable plastic cases provide **safe storage** for all tests and room to store supplemental tests or extra reagents.
- **Proven chemistries** are based on *Standard Methods for the Examination of Water and Wastewater*, APHA, Washington, DC, and/or *American Society for Testing and Materials*, ASTM, Philadelphia, PA. Some methods use proprietary chemistry developed by Taylor Technologies.

ALSO AVAILABLE

- **Unit Dose Dispenser** (#9250) that fits over the vial of DPD powder. When cranked, it serves up the correct amount to run the test, while protecting the powder from exposure to air and humidity.
- **Deox Reagent** to eliminate interference with the FAS-DPD chlorine test from monopersulfate (non-chlorine) shock treatments in the water; K-2041 (.75 oz.) or K-2042 (2 oz.).
- A wide array of single- and multiparameter kits featuring color-matching and/or drop-count tests.
- Taylor's **TTi® Colorimeter** (M-2000); test more than a dozen parameters commonly encountered in pool/spa settings and transfer results to a PC database.
- Myron L Company portable instruments.
- Testing supplies and kit replacement parts (e.g., burets, flasks, test tubes, and test cells).
- **Video demonstrations** for new users posted on our website.
- Toll-free technical assistance at **800-TEST KIT**.

REPRESENTATIVE TEST PROCEDURE

Reproduced from K-2006-SALT instruction:

Guidebook (#2004B) amplifies these instructions and should be read to use this product properly.		POOL & SPA WATER TESTS		Instr. #5138	
Free & Combined Chlorine Test 1. Rinse and fill large comparator tube to desired mark with water to be tested. NOTE: For 1 drop = 0.2 ppm, use 25 mL sample. For 1 drop = 0.5 ppm, use 10 mL sample. 2. Add 2 dippers R-0870. Swirl until dissolved. If free chlorine is present, sample will turn pink. NOTE: If pink color disappears, add R-0870 until color turns pink. 3. Add R-0871 dropwise, swirling and counting after each drop, until color changes from pink to colorless. 4. Multiply drops in Step 3 by drop equivalence (Step 1). Record as parts per million (ppm) free chlorine (FC). 5. Add 5 drops R-0003. Swirl to mix. If combined chlorine is present, sample will turn pink. 6. Add R-0871 dropwise, swirling and counting after each drop, until color changes from pink to colorless. 7. Multiply drops in Step 6 by drop equivalence (Step 1). Record as ppm combined chlorine (CC).		Total Alkalinity Test 1. Rinse and fill large comparator tube to 25 mL mark with water to be tested.* 2. Add 2 drops R-0007. Swirl to mix. 3. Add 5 drops R-0008. Swirl to mix. Sample should turn green. 4. Add R-0009 dropwise. After each drop, count and swirl to mix until color changes from green to red. 5. Multiply drops in Step 4 by 10. Record as parts per million (ppm) total alkalinity as calcium carbonate. * <i>When high TA is anticipated</i> , this procedure may be used: Use 10 mL sample, 1 drop R-0007, 3 drops R-0008, and multiply drops in Step 4 by 25.		3. Store test kit in cool, dark place. 4. Replace reagents once each year. 5. Do not dispose of solutions in pool or spa. 6. Rinse tubes before and after each test. 7. Obtain samples 18" (45 cm) below water surface. 8. Hold bottle vertically when dispensing.	
pH Test 1. Rinse and fill large comparator tube to 44 mL mark with water to be tested. 2. Add 5 drops R-0004. Cap and invert to mix. 3. Match color with color standard. Record as pH units and save sample if pH needs adjustment. If sample color is between two values, pH is average of the two. To LOWER pH: See acid demand test. To RAISE pH: See base demand test.		Calcium Hardness Test 1. Rinse and fill large comparator tube to 25 mL mark with water to be tested.* 2. Add 20 drops R-0010. Swirl to mix. 3. Add 5 drops R-0011L. Swirl to mix. If calcium hardness is present, sample will turn red. 4. Add R-0012 dropwise. After each drop, count and swirl to mix until color changes from red to blue. 5. Multiply drops in Step 4 by 10. Record as parts per million (ppm) calcium hardness as calcium carbonate. * <i>When high CH is anticipated</i> , this procedure may be used: Use 10 mL sample, 10 drops R-0010, 3 drops R-0011L, and multiply drops in Step 4 by 25.		Cyanuric Acid Test 1. Rinse and fill CYA dispensing bottle (#9191) to 7 mL mark with water to be tested. 2. Add R-0013 to 14 mL mark. Cap and mix for 30 seconds. 3. Slowly transfer cloudy solution to small comparator tube until black dot on bottom just disappears when viewed from top. 4. Read tube at liquid level on back of comparator block. Record reading as parts per million (ppm) cyanuric acid.	
Acid Demand Test 1. Use treated sample from pH test. 2. Add R-0005 dropwise. After each drop, count, mix, and compare with color standards until desired pH is matched. See treatment tables to continue.		Sodium Chloride (Salt) Test For 1 drop = 200 ppm 1. Rinse and fill sample tube (#9198) to 10 mL mark with water to be tested. 2. Add 1 drop R-0630. Swirl to mix. Sample should turn yellow. 3. Add R-0718 dropwise, swirling and counting after each drop, until color changes from yellow to a milky salmon (brick) red. Always hold bottle in vertical position. NOTE: Do not add enough R-0718 to give a brown color. First change from yellow to a milky salmon (brick) red is the endpoint. 4. Multiply drops of R-0718 by 200. Record as parts per million (ppm) salt as sodium chloride.		Base Demand Test 1. Use treated sample from pH test. 2. Add R-0006 dropwise. After each drop, count, mix, and compare with color standards until desired pH is matched. See treatment table to continue.	