

Figure 13. Typical wood-framed breakaway wall construction (prescriptive method)

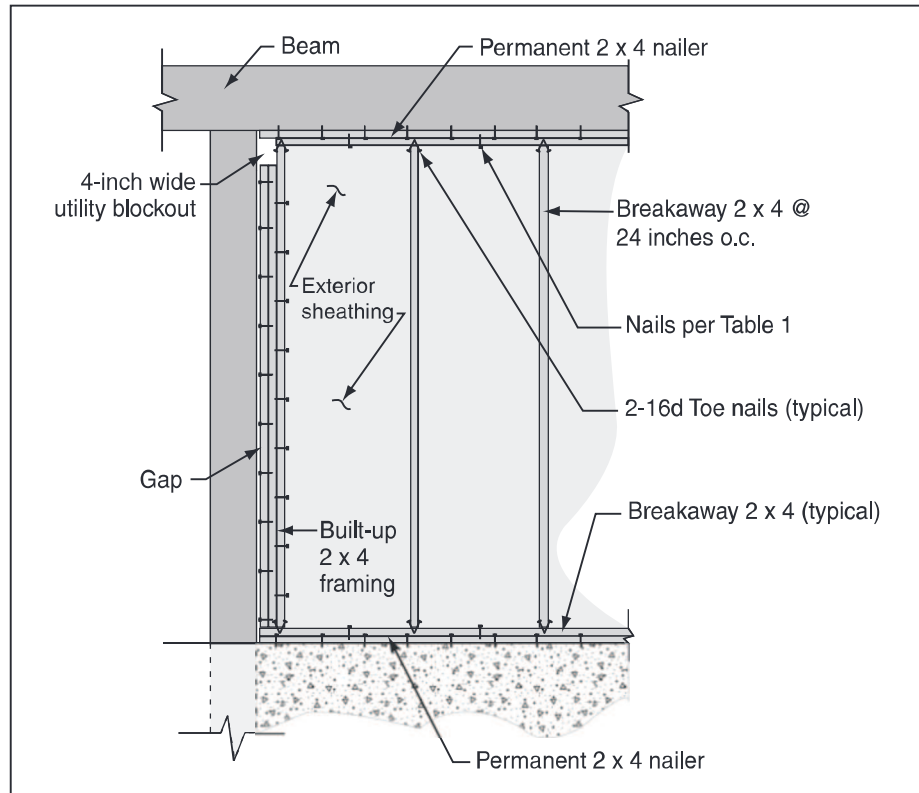

Table 1a. Total required number of galvanized common nails (divided equally between top and bottom) for wood-framed breakaway wall configurations with 8-foot pile spacing

Breakaway Wall Height (feet)	6		7		8		9	
Nail Size	8d	10d	8d	10d	8d	10d	8d	10d
Nails Required	18	12	22	14	24	16	28	18

Table 1b. Total required number of galvanized common nails (divided equally between top and bottom and evenly spaced) for wood-framed breakaway wall configurations with 10-foot pile spacing

Breakaway Wall Height (feet)	6		7		8		9	
Nail Size	8d	10d	8d	10d	8d	10d	8d	10d
Nails Required	24	16	28	18	32	20	34	24

Table 1c. Total required number of galvanized common nails (divided equally between top and bottom and evenly spaced) for wood-framed breakaway wall configurations with 12-foot pile spacing

Breakaway Wall Height (feet)	6		7		8		9	
Nail Size	8d	10d	8d	10d	8d	10d	8d	10d
Nails Required	28	18	32	22	38	24	42	28