

OPTIONAL METAL ROOFING
 OPTIONAL METAL ROOFING SHALL BE 29 GAGE OVER 1/2" OSB SHEATHING WITH 29 GAGE RIDGE CAP, EAVE TRIM AND RAKE TRIM. SCREEN CLOSURE OVER RIDGE OPENING.

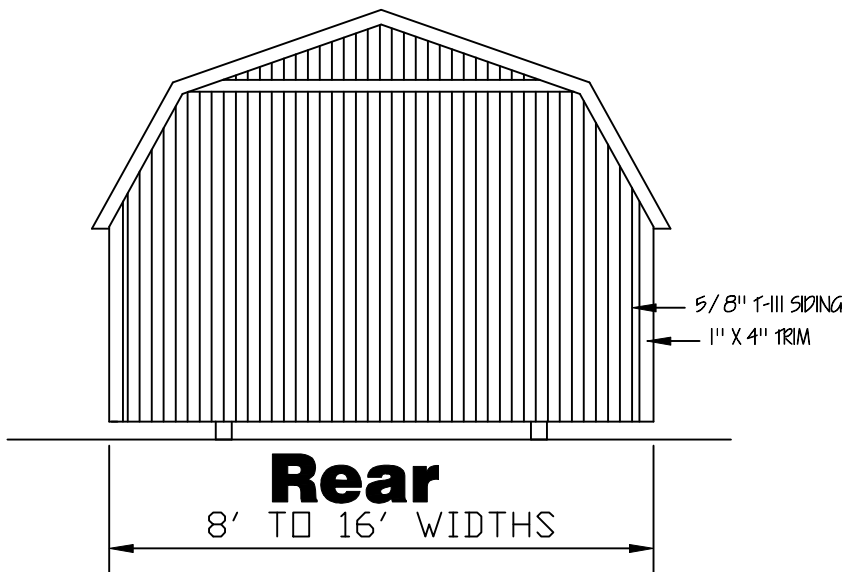

ANCHORS: IRON ROOT DOUBLE HEAD DOUBLE HELIX EARTH ANCHORS, 30" LONG BY 3/4" W/ 2-4" HELIX FOR SOIL CLASS 2 1-1/4" FRAME TIE GALVANIZE STRAP WITH BUCKLE AND SLOTTED BOLTS CENTERED BETWEEN EACH PIER

GIRDERS: TWO REQUIRED FOR 8' and 10' BUILDINGS AND FOUR REQUIRED FOR 12', 14' and 16' BUILDINGS.

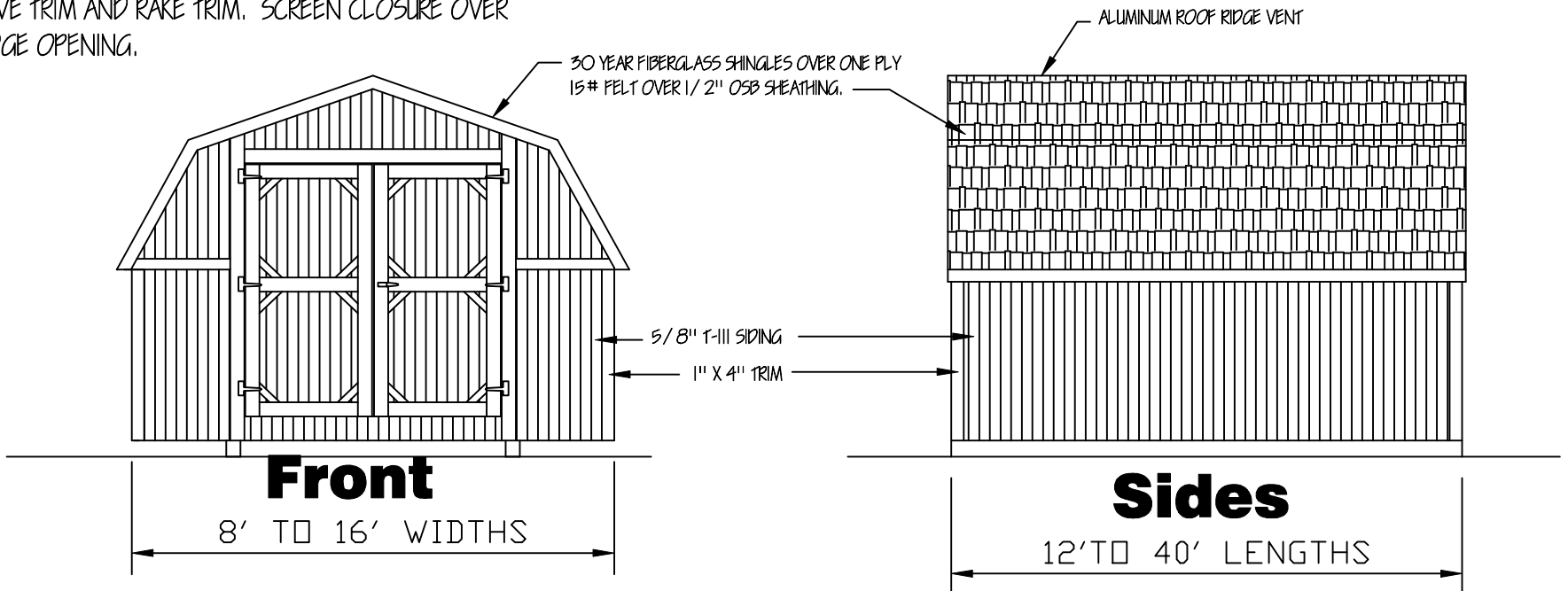
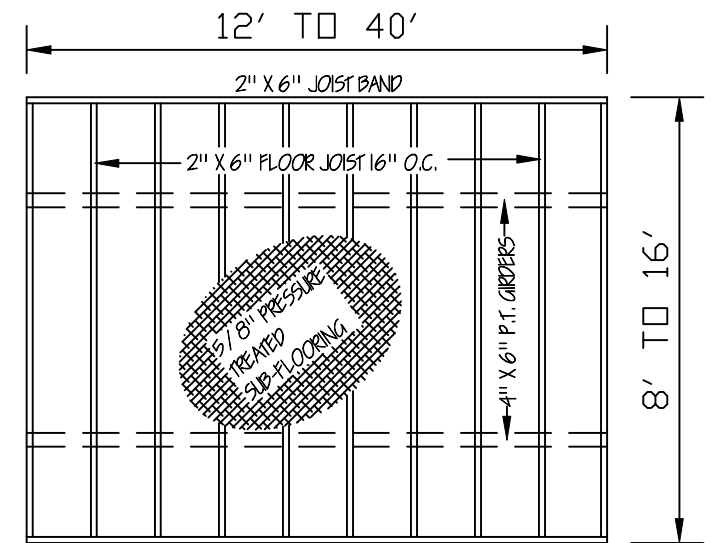
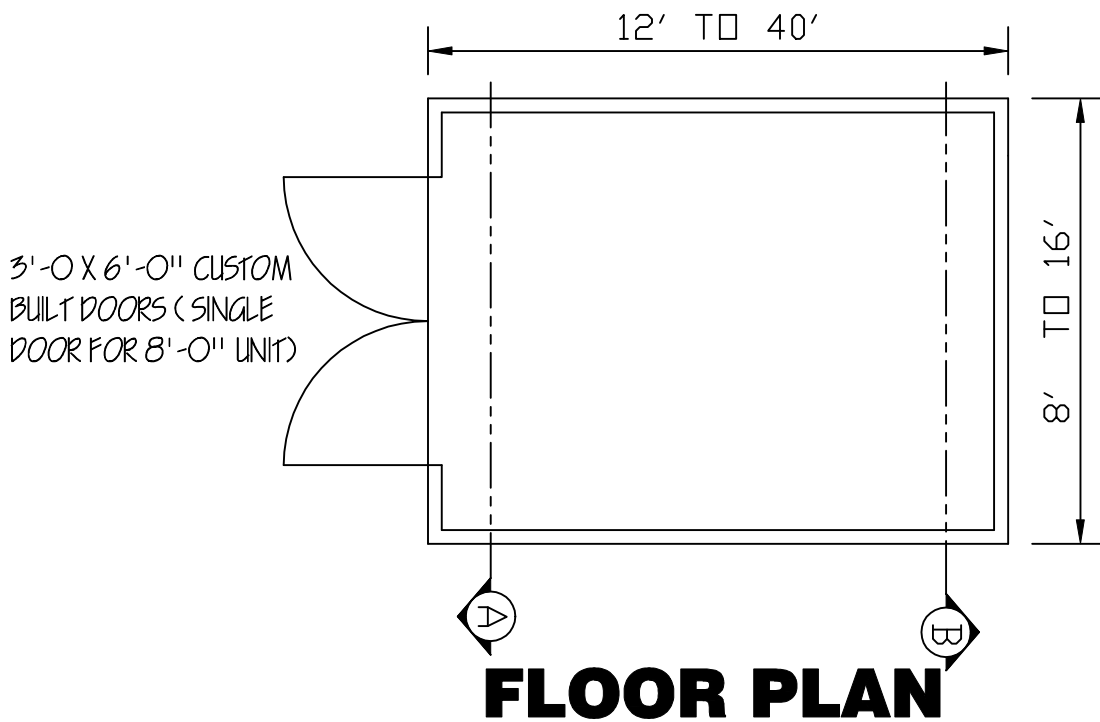

FLOOR FRAMING

GIRDERS: TWO REQUIRED FOR 8' and 10' BUILDINGS AND FOUR REQUIRED FOR 12', 14' and 16' BUILDINGS.

MEASURES SHALL BE TAKEN DURING CONSTRUCTION TO INSURE THAT ONLY WORKMANSHIP OF THE HIGHEST QUALITY IS PERFORMED AND THAT ONLY THE BEST MATERIALS AND PRACTICES OF CONSTRUCTION ARE USED FOR A QUALITY AND SOUND BUILDING.

BUILDINGS 14'-0" AND 16'-0" WIDE, STUDS 16" O.C.

NOTE: THE BARN FLOORING, WALLS AND ROOF ARE DESIGNED TO COMPLY WITH THE 2012 INTERNATIONAL BUILDING AND INTERNATIONAL RESIDENTIAL CODES. THEY ARE NOT INTENDED FOR RESIDENTIAL USE. FOR RESIDENTIAL USAGE 'ALL' STATE AND LOCAL CODES MUST BE MET INCLUDING BUT NOT LIMITED TO CEILING HEIGHTS, OPENINGS, ELECTRICAL, PLUMBING ETC.

ENGINEERS' NOTES:

1. FOUNDATIONS PIERS, TIE-DOWNS AND ANCHORS SHALL MEET THE REQUIREMENTS OF THE "PERMANENT FOUNDATIONS GUIDE OF MANUFACTURED HOUSING" AS PUBLISHED BY HUD IN SEPTEMBER 1996, AND THE HUD HANDBOOK 4145.1 REV. 2.
2. NO FIELD SUPERVISION PROVIDED UNDER THIS SEAL.
3. NO ADMINISTRATION PROVIDED UNDER THIS SEAL.

WIND CERTIFICATION
 WIND EXPOSURE CATEGORY 'C'
 BASIC WIND SPEED (3 SECOND GUST) 150 M.P.H.

The Barn

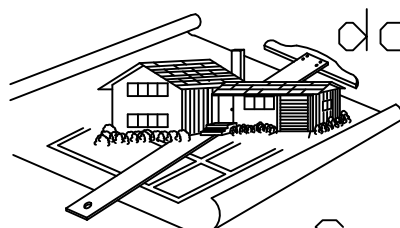

doug's
 plan
 Service

4210 Stewart Lane
 Perkinston, MS 39573
 228/255-5259

GRACELAND PROPERTIES LLC
 P.O. BOX 665
 CUNNINGHAM, KY 42035

Copyright (C) 2008 by Graceland Properties LLC
 All Rights Reserved, including the rights of reproduction in whole or in part in any form.