

VG60 SERIES GAS RESTAURANT RANGE



SPECIFICATIONS:

60" wide gas restaurant range, Vulcan-Hart Model No. VG60. Stainless steel front, sides, back riser, high shelf and 6" adjustable legs. Ten 20,000 BTU/hr. cast top burners with lift-off burner heads. Individual pilot for each burner. 12" x 24" aeration plates and removable 12" x 12" top grates finished with matte black porcelain. Full width pull-out crumb trays under burners. Two 35,000 BTU/hr. standard ovens measure 26 $\frac{1}{4}$ "w x 22"d x 14 $\frac{1}{2}$ "h. Thermostats adjust from 150° to 500°F. One oven rack and two rack positions per oven. $\frac{3}{4}$ " rear gas connection and gas pressure regulator. Total input 270,000 BTU/hr.

Exterior dimensions: 60"w x 31 $\frac{7}{8}$ "d x 59 $\frac{1}{2}$ "h on 6" adjustable legs. 36 $\frac{1}{2}$ " working height.

AGA design certified and NSF listed.

SPECIFY TYPE OF GAS WHEN ORDERING.

SPECIFY ALTITUDE WHEN ABOVE 2,000 FT.

STANDARD FEATURES

- Stainless steel front, sides, back riser, high shelf and 6" adjustable legs.
- Ten 20,000 BTU/hr. cast top burners with lift-off burner heads. Individual pilot for each burner.
- 12" x 24" aeration plates and removable 12" x 12" top grates finished with matte black porcelain.
- Full width pull-out crumb trays under burners.
- Two 35,000 BTU/hr. standard ovens measure 26 $\frac{1}{4}$ "w x 22"d x 14 $\frac{1}{2}$ "h. Thermostats adjust from 150° to 500°F. One oven rack and two rack positions per oven.
- $\frac{3}{4}$ " rear gas connection and gas pressure regulator.
- One year limited parts and labor warranty.

OPTIONS

- $\frac{1}{2}$ " thick, 24" wide polished steel griddle plate on the right. 15,000 BTU/hr. burner per 12" griddle width. One manual control valve per burner.
- Set of four casters, two locking.
- Extra oven rack(s).
- Gas shut-off valve, $\frac{3}{4}$ " N.P.T.
- Flexible gas hose with quick disconnect and restraining device. Consult price book for available sizes.



VG60 SERIES

GAS RESTAURANT RANGE

IMPORTANT

1. A pressure regulator sized for this unit is included. Natural gas 3.7" W.C., propane gas 10" W.C. manifold pressure.
2. Gas line connecting to range must be 3/4" or larger. If flexible connectors are used, the inside diameter must be at least the same as the 3/4" iron pipe and rated for the correct gas input.
3. An adequate ventilation system is required for commercial cooking equipment. Information may be obtained by writing to the National Fire Protection Association, Batterymarch Park, Quincy, MA 02289. When writing, refer to NFPA No. 96.
4. These units are manufactured for installation in accordance with ANSZ223.1A (latest edition), National Fuel Gas Code. Copies may be obtained from the American Gas Association, 1515 Wilson Blvd., Arlington, VA 22209.
5. Clearances:

	Combustible	Non-combustible
Rear	6"	6"
Sides	6"	0"
6. This appliance is manufactured for commercial installation only and is not intended for home use.

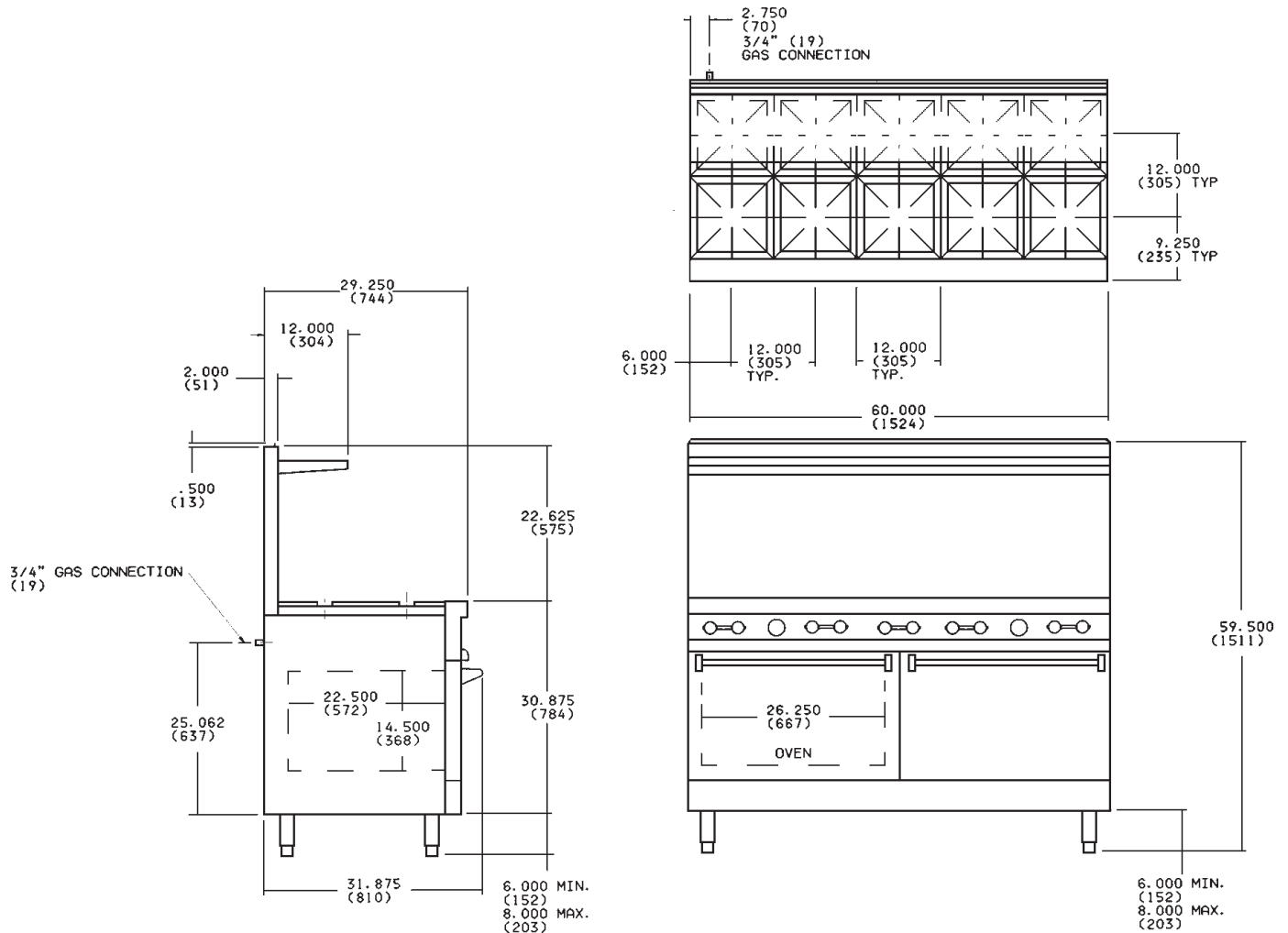

NOTE: In line with its policy to continually improve its products, Vulcan-Hart Company reserves the right to change materials and specifications without notice.