

**SERVICE MANUAL MODEL 232W
FROSTY FACTORY OF AMERICA INC.
RUSTON, LA. 71270
(318)255-1162**

All technical data, pictures and drawings contained in this manual are not binding on the manufacturer nor can the manufacturer be held liable for any modifications to the machine in whole or in part.

Rev.4/21/00 rf

SECTION 1 INTRODUCTION

1.1 USE OF THIS MANUAL

Your service manual has been prepared as a guide to help you get the most from your Sorbeteer. It contains information about the installation and operation of your machine. The manual also contains instructions for service and care. The manual should be read carefully by the operator of the Sorbeteer to become familiar with the machine and the correct operating procedures described within. The following notations are used throughout the manual to bring important facts to your attention:

- “Warning”** - This notation is used whenever the personal safety of the operator(s) might be jeopardized, if procedures are not followed correctly.
- “Caution”** - This notation is used whenever the machine or related equipment may receive or cause damage if not observed.
- “Note”** - This notation is used to bring important information to your attention that will enhance the performance of your machine.

1.2 PRELIMINARY INSPECTION

Unpack the unit as soon as possible upon its arrival. Check the entire machine and its contents for possible shipping damage. Note damage, if any, and notify your carrier immediately. Frosty Factory of America cannot be responsible for damaged merchandise caused by shipping. Inventory the accessories to be sure they include the items you specified on your order. Normally the accessories include:

- ___ Beater Bar
- ___ Drip Tray
- ___ Face Plate
- ___ Face Plate Knobs
- ___ Hopper Cover
- ___ Petro-Gel
- ___ Sanitizer
- ___ Spare Faucet O-Rings
- ___ Warranty Card
- ___ Water Hoses
- ___ Wire Brush

1.3 DESCRIPTION

The Sorbeteer is manufactured with a high quality stainless steel cabinet which houses a restaurant grade stainless steel hopper and cylinder which is attached to a sturdy, hand-crafted steel frame. The hopper and cylinder are joined by a feed hole to allow gravity flow operation. The drive motor is mounted within the frame and rotates counter clockwise (as viewed from the front of the machine). Panels are stainless steel with plastic louvered inserts to allow maximum airflow for cooling. A stainless steel beater assembly is installed in the cylinder and held in place by a clear plastic faceplate, which in turn is held onto the face of the machine with four attractive knobs. Four adjustable legs are installed for leveling. Mix dispensing is provided for via a specially designed “drip-free”, automatic closing faucet assembly.

1.4 SPECIFICATIONS

Freezing Cylinder

One, 12 quart (11.5 liter) capacity.

Electrical

Standard is 220V/60Hz/1Ph. 15 total amps with a 20 amp cord.

Mix Hopper

One, 12 quart (11.5 liter) capacity.

Dimensions

Width: 16.5” (42 cm)

Depth: 24.5” (61 cm)

Height: 28.5” (72 cm)

Floor Clearance: 4” (10 cm)

Refrigeration Unit

Internally mounted condensing unit.

Compressor: 2 H.P. 14,000 BTU/Hour

Refrigerant: R404

Suction Pressure: 30 psi

Approximate Weights

Net: 215 lbs.

Crated: 225 lbs.

Volume: 13.0 cu. Ft.

Beater Motor

One, 1/3 hp. Motor

* Specifications subject to change without notice

This unit is designed and constructed to meet stringent safety and sanitation requirements for NSF and UL.

SECTION 2

LOCATION & INSTALLATION

2.1 SAFETY PRECAUTIONS

Do not attempt to operate your Sorbeteer until the safety precautions and operating instructions in this manual are read completely and are thoroughly understood.

Take notice of all warning labels on your Sorbeteer. The labels have been put there to inform and protect persons servicing your equipment. Care must be taken not to damage or destroy labels during installation and servicing. The labels have been designed to withstand routine cleaning and handling. Damaged or missing labels should be promptly replaced with approved labels from Frosty Factory of America Inc.

2.2 INSTALLATION

Placing your Sorbeteer in a highly visible area will enhance sales. A suitable station will be able to support 250 pounds and will have a dedicated electrical outlet.

CAUTION: Do not attempt to share the dedicated electrical outlet with any other appliance, this will cause the circuit breaker to trip.

1. Uncrate your Sorbeteer.
2. The Sorbeteer must be placed in a sturdy platform in a level position.
3. Sorbeteers equipped with water cooled condensers require less ventilation than air-cooled units. Water intake is at the rear of the Sorbeteer. All Sorbeteers require 6" clearance at the top.

NOTE: Locating the unit in direct sunlight, near cooking facilities or any high heat area will reduce the performance of your machine.

CAUTION: Extended operations under severe heat condition can damage the cooling system.

NOTE: Any establishment serving beverages from frozen drink machines is responsible for providing the necessary facilities for cleaning and sanitizing their food service equipment.

4. Place the three-position switch in the OFF position (center).
5. Connect the power cord. The Sorbeteer must be connected to a properly grounded receptacle. The electrical cord furnished as part of the Sorbeteer has a three prong grounding type plug. The use of an extension cord is not recommended. If one must be used, consult the national and local electrical codes. **Do not** use an adapter to get around grounding requirements.

WARNING: Do not attempt to alter the electrical plug. Serious injury or electrocution may result.

6. Install the drip tray, cover and other miscellaneous parts on the Sorbeteer.

SECTION 3

OPERATION

3.1 MACHINE CONTROLS

Two selector switches located on the front of the machine control operation of the Sorbeteer. Selection of the right (snowflake) position with the upper (three-position) switch as well as the lower (two-position) switch will schedule the machine for normal operation. The compressor cycle is protected by a time delay circuit, which will engage the compressor approximately 2 minutes after normal operation is initiated. The red fill light located above the switches will illuminate when the level of mix is low in the hopper. A thermostat knob is visible on the electrical control box of your machine. This is set at the factory and should not be changed except by an authorized service repairman.

Refer to the chart below for functions available with various combinations of switch positions.

Normal Operation - Machine will freeze mix to provide frozen beverage as desired.

Cooling Operation - Machine will automatically come on whenever necessary to keep mix cooled to 5° C/40° F - used primarily for overnight storage of mix remaining in the machine.

Cleaning Operation - The drive motor will run in the faucet position to allow a stirring action of the rinse water while cleaning.

Off - The hand symbol is the recognized international symbol for “stop”. In this position, the machine will not run.

3.2 THE PRODUCT YOU SERVE

The Sorbeteer will produce a fine grain, semi-frozen slush when the proper mix is used. Then measured with a refractometer, the proper mix will measure 12 to 18 “brix”. Too

little sugar in the mix will cause larger ice crystals to form. Too much sugar will lengthen the freeze time.

CAUTION: Any attempt to freeze water only will cause severe damage to your machine.

NOTE: Do not add sugar directly into the machine, as some of it will settle and result in an improper mix.

FRUIT JUICES: with at least 32 grams of sugar per 8 oz. Serving will freeze well in the Sorbeteer. They will remain stable during the freezing process while retaining their natural color and flavor.

NEUTRAL BASES are used to produce a neutral frozen cocktail base. A wide variety of different drinks can be created from one neutral base by the addition of various flavors. Most brands of neutral bases specify a mixture of four parts water to one part neutral base. However, before use in the Sorbeteer, be sure the “brix” level is 12 to 18.

The amount of **ALCOHOL** in the recipe will affect the freezing process. As a rule of thumb, for the mix to freeze properly, the recipe should contain no more than 25 percent alcohol.

Suggestion for optimum production and sales:

- 1) Use the finest ingredients available.
- 2) Test the product before serving it.
- 3) Keep the machine clean - **ALWAYS!**

3.3 PRODUCT CONSISTENCY

An exclusive torque sensing mechanism developed by Frosty Factory of America allows for the production of consistent texture and thickness of your frozen beverages. The adjustment screw (accessible through the left side panel as you face the machine front) is pre-set at the factory. Various mix consistencies can be achieved by turning the screw clockwise (thicker drink) or counter clockwise (thinner drink). Turn the screw one full turn then allow enough time to lapse (about three minutes) for the compressor to complete a cycle before sampling. Continue this process until desired result is obtained.

3.4 START UP

NOTE: Before start-up, be sure the machine has been sanitized in accordance with procedures set forth in the cleaning section of this manual.

Pour the mix into the hopper and allow it to drain into the cylinder. When the hopper and cylinder are full (normally about one inch from the top of the hopper) the machine is ready to run. Turn on by selecting the “right” (snowflake) position of both switches on the front panel.

NOTE: Add mix as soon as the red light comes on to prevent air from entering the cylinder.

CAUTION: Allowing air into the cylinder will cause a gentle rocking motion of the machine. If the mix is not yet frozen the air will escape by turning the machine off for 20-30 seconds.

NOTE: Pre-cooling the mix will reduce freeze-time, example: mix poured in at 40° F will freeze in half the time of mix at 80° F.

WARNING: **NEVER** under any circumstances, place your finger or any other object into the hopper or feed hole while the machine is in operation. Serious personal injury may occur.

3.5 FREEZE TIME

The freeze time on the Model 232W is approximately 15 minutes. This figure is based on **ideal conditions** with a starting mix temperature of approximately 40 degrees. The time will increase if the machine is not properly ventilated or is operated in a hot environment. Some recipes with high alcohol or high sugar content will naturally take a little longer.

<p style="text-align: center;">SECTION 4 MAINTENANCE</p>

4.1 CLEANING

The following cleaning procedure should be used for initial start-up and on a weekly basis during the service life of your machine:

- (1) Turn the machine to the off, “hand” position.
- (2) If applicable, drain mix into a sanitized container as per local health code procedures. Store in an adequate cooling facility.

NOTE: Do not put hands or foreign matter into mix.

- (3) Pour two gallons of cool water (approximately 75° F) into the hopper. Clean the hopper and feed hole with appropriate brush or cleaning device. Place upper switch in “faucet” position to let the machine stir. Drain and dispose of the rinse water. Repeat until water is clear.
- (4) Mix two gallons of warm water (approximately 100° F) with two ounces of sanitizing powder to achieve 100 parts per million (PPM) chloride solution.
- (5) Pour the sanitizing solution into the hopper. Clean the hopper and feed hole with brush or other suitable device. Place upper switch in “faucet” position. Let solution stir for several minutes. Then, turn machine off and drain the solution. Rinse with fresh water and drain.
- (6) Remove the knobs from the faceplate by turning in a counter clockwise direction. Carefully pull the faceplate straight away from the front of the machine. Remove the beater bar assembly from the cylinder. Then slide the spring seal off the rear of the beater bar.
- (7) Unscrew the white hex shaped cap from the front end of the faucet assembly. Then pull the plunger out of the faucet body. Remove plastic clip ring and float from the fill switch located in sink hopper.

NOTE: Do not unscrew faucet body from faceplate to clean. (Leak free service after disturbing the Teflon seal cannot be assured).

- (8) All parts removed during the above steps plus the drip tray can now be cleaned in your warm (100° F) sanitized solution. Rinse all parts in clean rinse water and allow to air-dry before re-assembly.

4.2 RE-ASSEMBLY

- (1) Using Petro-Gel (or other sanitary food grade lubricant), lightly lubricate the longer end of the beater shaft. Slide beater seal onto the shaft with the spring end toward the beater bar.

NOTE: The black carbon ring must be facing the end of the beater bar so it will be in direct contact with the white ceramic seat inside the cylinder when the beater is re-installed. This is a dry seal and must be kept free of lubricants.

NOTE: The beater seal may become damaged if the beater shaft is not lubricated before installation of the beater seal.

- (2) Insert the beater bar (with beater seal) into hole at the rear of the cylinder and rotate until it fully engages into the drive coupling.
- (3) Lubricate the large, black, rubber face plate O-ring (but not the white face plate bushing) with Petro-Gel then re-install and press firmly into the faceplate groove for proper fit.
- (4) Re-install the faceplate on the machine. First place the faceplate bushing onto the beater shaft. Then slide face plate onto the four studs. Now re-attach the faceplate knobs and tighten evenly until the face plate O-ring is snug against the cylinder.

CAUTION: If you over tighten the knobs or tighten against a beater bar that is not fully engaged in the drive coupling permanent distortion to the face plate may occur!

- (5) Lubricate the faucet plunger O-rings with Petro-Gel then reassemble the faucet. Place the float back on the float switch (in the hopper) with the two “dots” facing up then re-install the clip.
- (6) The machine is now reassembled. All smudges, blemishes, and handprints should be removed to return the machine to a high luster.

4.3 PREVENTATIVE MAINTENANCE

It is recommended that a maintenance schedule be followed to keep the machine clean and operating properly.

WARNING: Never attempt to repair or perform maintenance on machine until the main electrical power has been disconnected.

A. DAILY

1. The exterior of the machine should be kept clean at all times to preserve the luster of the stainless steel. A mild alkaline cleaner is recommended. Use a soft cloth or sponge to apply the cleaner.

B. WEEKLY

- (1) Check O-rings and rear seal for excessive wear and replace if necessary.
- (2) Clean the drip tray and front of the machine with a soap solution.

4.4 EXTENDED STORAGE

Refer to the following steps for storage of the machine over any long period of shutdown time:

- (1) Turn the three position switch to the OFF (center) position.
- (2) Disconnect (unplug) from the electrical supply source.
- (3) Clean thoroughly with a warm detergent all parts that come in contact with the mix. Rinse in clean water and dry all parts. Do not sanitize. Sorbeteer parts can be left assembled or disassembled until ready for use.

NOTE: Do not let the cleaning solution stand in the hopper or in the cylinder during the shutdown period.

4.5 TROUBLESHOOTING

1. Machine does not run when turned on.

- A. Be sure that the cord is properly plugged into wall outlet.
- B. Check to reset circuit breaker if necessary.
- C. Be sure that no other appliances are sharing the circuit.
- D. If problem remains, call service repairman.

2. Beater motor starts but compressor doesn't.

- A. Both switches must be in the right (Snowflake) position.
- B. Allow approximately one or two minutes for time delay to respond.
- C. Check that the micro-switch at the drive motor is depressed.
- D. If necessary adjust TCC screw to depress micro-switch.
- E. If problem remains, call service repairman.

3. Mix dripping from drip tube.

- A. Spring seal on beater bar is dirty or improperly installed. Remove, clean and re-install spring seal assembly according to instructions and diagram on top of the hopper cover.
- B. Ceramic seal (inside the freezing cylinder) is dirty or loose. Clean ceramic seal. If loose re-install as necessary. Also check that the carbon ring on the seal is not chipped, cracked, dirty or greasy. Replace seal if necessary.

4. Unit runs but product does not freeze to desired consistency.

- A. Check recipe for proper amount of sugar.
- B. Check tension of TCC screw, if necessary turn clockwise to increase tension to produce a thicker drink.
- C. Check to see if the water hoses are crimped.
- D. Be sure that the water is turned on and flowing.
- E. Be sure the cylinder is full of mix.

- F. If problem remains, call service repairman.
- 5. Unit runs but produces a loud knocking sound during initial freeze down cycle.**
- A. Cylinder not full. Turn unit off and fill hopper with mix.
 - B. Ice build-up. Check recipe for proper amount of sugar.
 - C. To clear ice build-up, turn top switch to left (faucet) position until knocking stops then turn switch back to the right (snowflake) position. Repeat as necessary.
- 6. Fill light is on when hopper is full of product.**
- A. Remove and re-install float with two dots facing up.
 - B. If float is stuck, clean float and stem and re-assemble.
 - C. If fill light circuit is defective call service repairman.
- 7. Machine has gentle “rocking” motion.**
- A. Air in cylinder- Turn unit off for about one minute to allow air to escape from cylinder. Cylinder must be full to freeze properly.
 - B. Be sure machine is level and all adjustable feet are touching counter top.
- 8. No product comes out when faucet handle is pulled while unit is running.**
- A. Frozen product is blocking “feed hole”. **Turn machine off** then clear ice plug from feed hole.
- WARNING: Never place fingers in the “feed hole” as serious personal injury may occur.**
- B. Mix is frozen solid. Low sugar content, product separation or cylinder not full.
- 9. Compressor starts and stops intermittently.**
- A. Be sure that the water is turned on and flowing.
 - B. If the on/off time is 30 seconds or longer, this is normal if product is frozen and no product has been pulled in a while.
 - C. If the problem is causing the breaker to trip, call service repairman.
- 10. Unit continues to run when switched to stand-by.**
- A. Have qualified technician remove back panel and reset thermostat. (turn all the way off then turn all the way on again.)
 - B. If problem remains call service repairman.
- 11. Beater bar does not turn**
- A. Belt is broken. Replace as necessary.
 - B. Belt off pulley or loose. Check pulley alignment, re-install and tighten belt.
 - C. Mix is frozen solid. See item 8-B.
 - D. Drive plate stripped. Call service repairman.
 - E. Faulty motor. Call service repairman.

BULKHEAD, WATER-BRACKET ASSEMBLY
EXPLODED VIEW

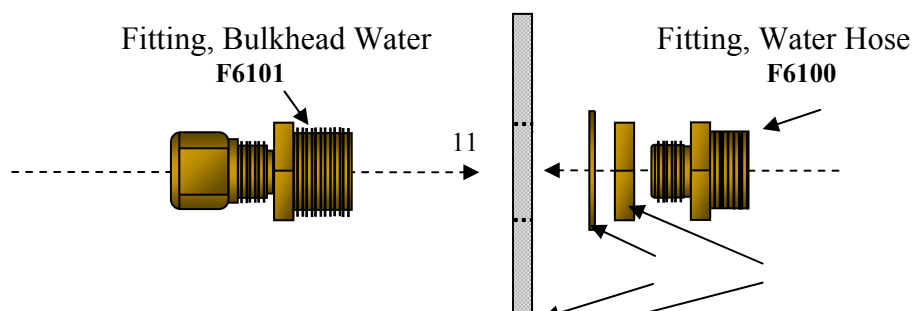

Star Washer Nut

Frame

Bracket, Water Refrigeration
F0200

1. Insert the water bulkhead fitting P.N. F6101 through the bracket hole.
2. Place the star washer over the threaded portion of the bulkhead fitting.
3. Install the nut onto the threaded portion of the bulkhead fitting.
4. Apply thread tape to the water hose fitting P.N. F6100 and install into the bulkhead fitting.

Note: Do not over-tighten the water hose fitting.

Beater Bar Spring Installation

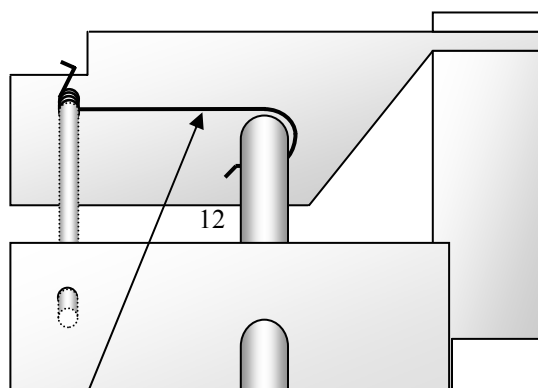

Rod →



Spring position is shown without scraper blade for clarity

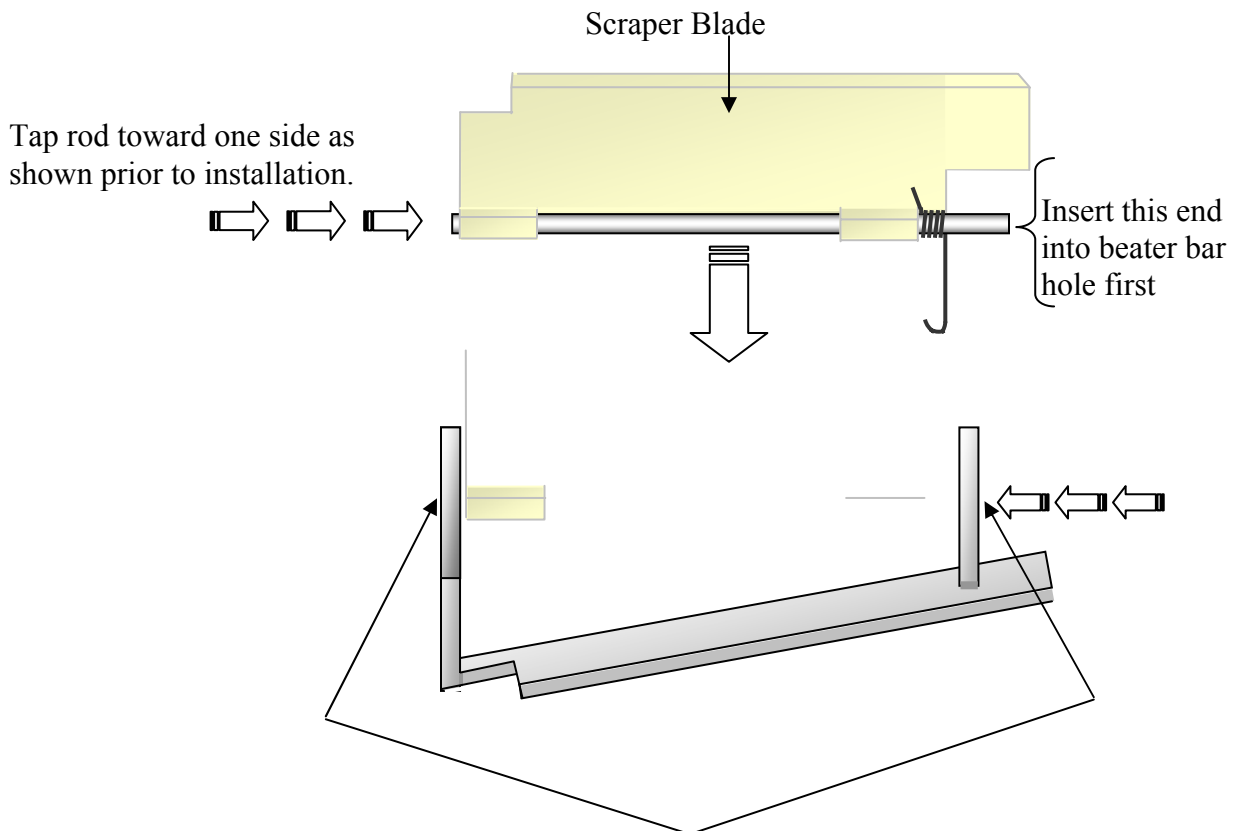

After installation tap rod until evenly spaced in beater bar as shown.

Beater Seal Assembly

1. Using Petro-Gel (or other sanitary food grade lubricant), lightly lubricate the longer end of the beater shaft. Slide beater seal onto the shaft with the spring end toward the beater bar. (Refer to diagram in this section of your manual or on top of the hopper cover for correct installation of spring seal).
2. The black carbon ring must be facing the end of the beater bar so it will be in direct contact with the white ceramic seal inside the cylinder when the beater bar is re-installed. **This is a dry seal and must be kept free of lubricants.** Lube the beater bar shaft ONLY!

- The beater seal may become damaged if the beater shaft is not lubricated before installation of the beater seal.

BEATER-BAR SEAL INSTALLATION

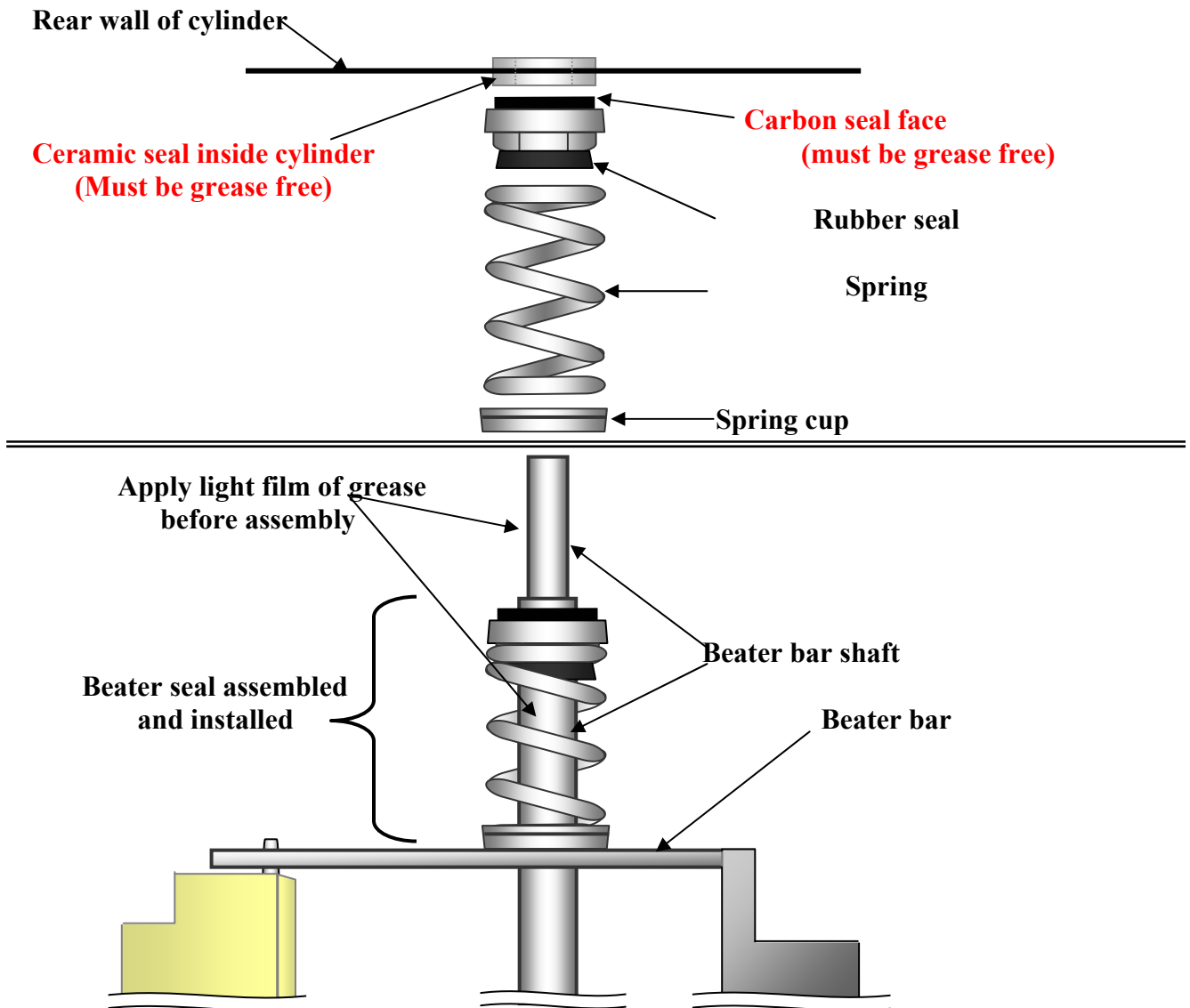

Face Plate / Faucet Assembly

- The face plate assembly consists of a plastic faceplate, face plate o-ring, and face plate bushing. Lubricate the o-ring before installation. The bushing is pressed into the faceplate and does not require lubrication.
- The faucet assembly includes the faucet body, a hex head security nut, plunger assembly and two O-rings. Lubrication of the O-rings is essential. Application of Petro-Gel or other restaurant grade lubrication to the inside surface of the faucet body will insure easier operation of the plunger.
- The plunger consists of a round pull knob, screw on cap, stainless steel rod spring and a plunger with grooves for the two o-rings.

Assembly Steps

1. Faucet body. Screw the chrome nut onto the longer threaded end of the faucet body, with the curved side of the nut toward the faucet body. Apply 5 wraps of Teflon tape around the threads. Screw the faucet body into the faceplate. (If the faucet screws in too easily, remove and add a few wraps of Teflon and try again.) Align the oval shaped opening in the faucet body (where the mix comes out) so that after installed it will be toward the bottom of the faceplate (as shown). While holding the faucet body so it will not turn, tighten the chrome nut towards the faceplate until snug. **Do not over-tighten!**
2. Plunger assembly. Install both O-rings onto the plunger drum. Lightly lubricate the o-rings and the inside surface of the faucet body. Insert the plunger assembly into the faucet body and screw the white cap onto the threaded collar until snug.
3. Lubricate the face plate o-ring with Petro-Gel and place the o-ring into the groove. The faceplate is ready for installation on the machine. (Don't forget to put the beater bar in the cylinder first.)

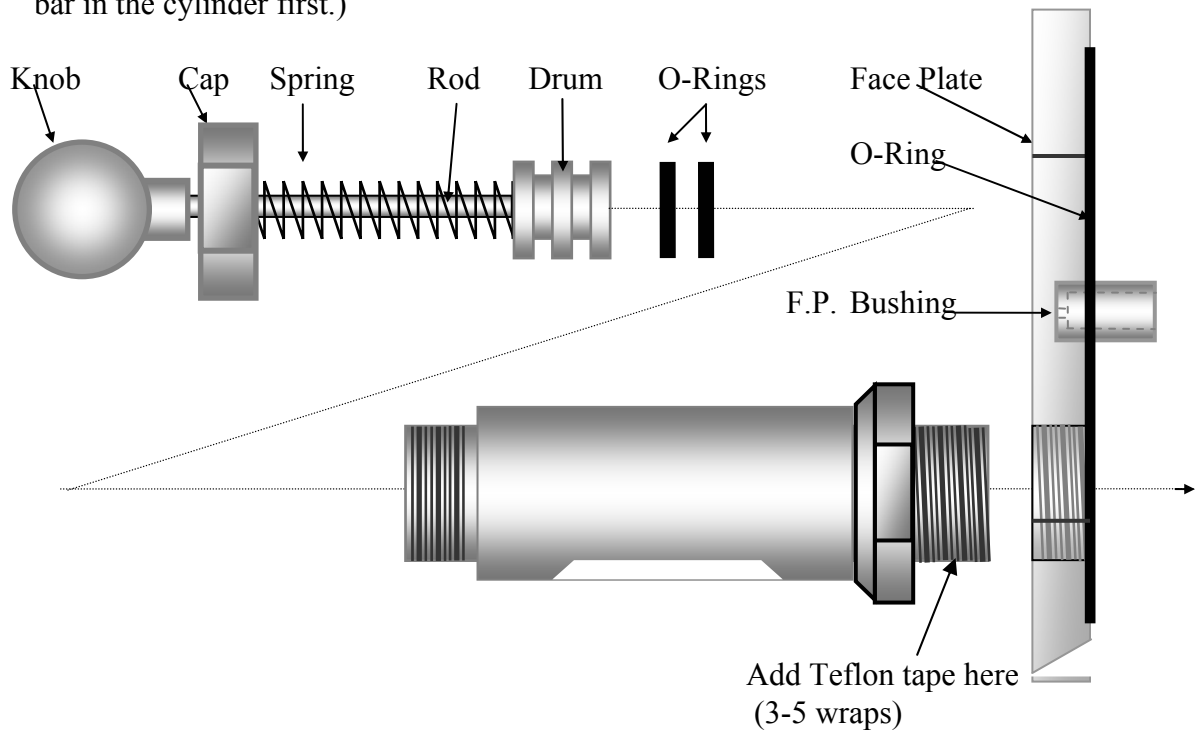

FLOAT SWITCH ASSEMBLY

1. The float switch assembly consists of: Post switch, Float, Float clip, O-Ring and Nut.
2. There are two dots on one end of the float. When assembled the two dots must be on the top end of the float.
3. Place O Ring so that it will be inside the hopper (sink bottom) when finished.

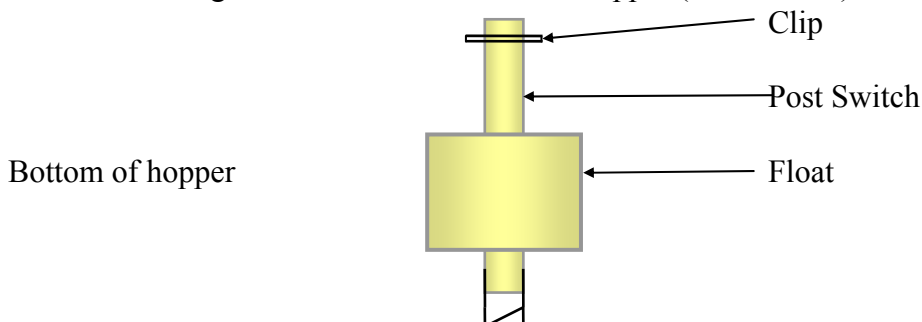

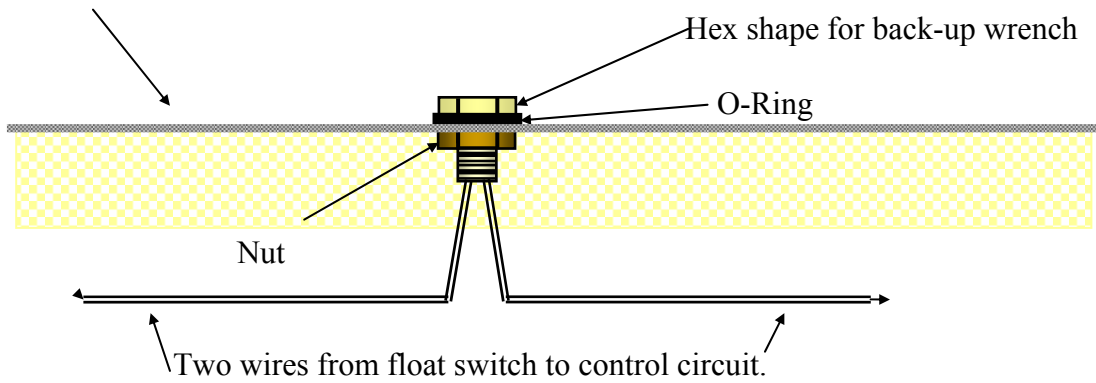

Top View of Float Switch

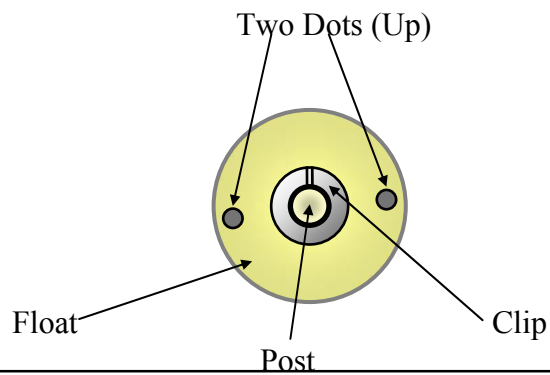

Thermostat System-Stand-By

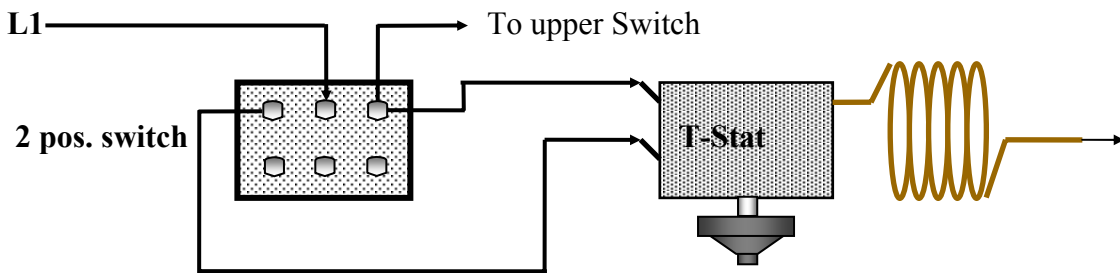

Ceramic Seal
Removal and replacement

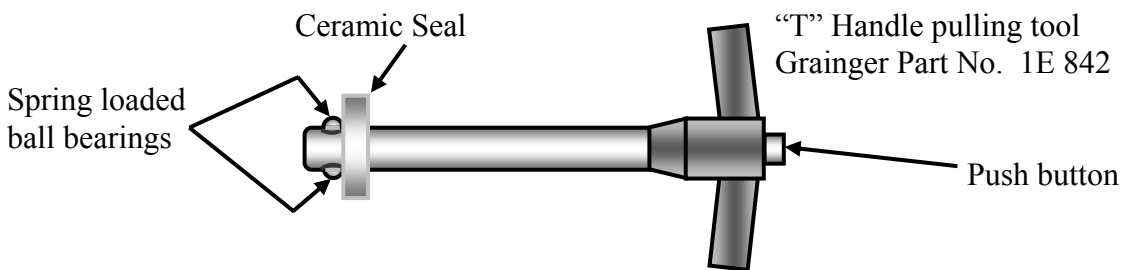

To remove old seal:

1. Press the "Push button" to release ball bearings.

2. Insert "T" handle through ceramic seal at rear of cylinder.
3. Release "Push button".
4. Quickly pull "T" handle straight out and the ceramic seal will remain on the "T" handle as shown above.

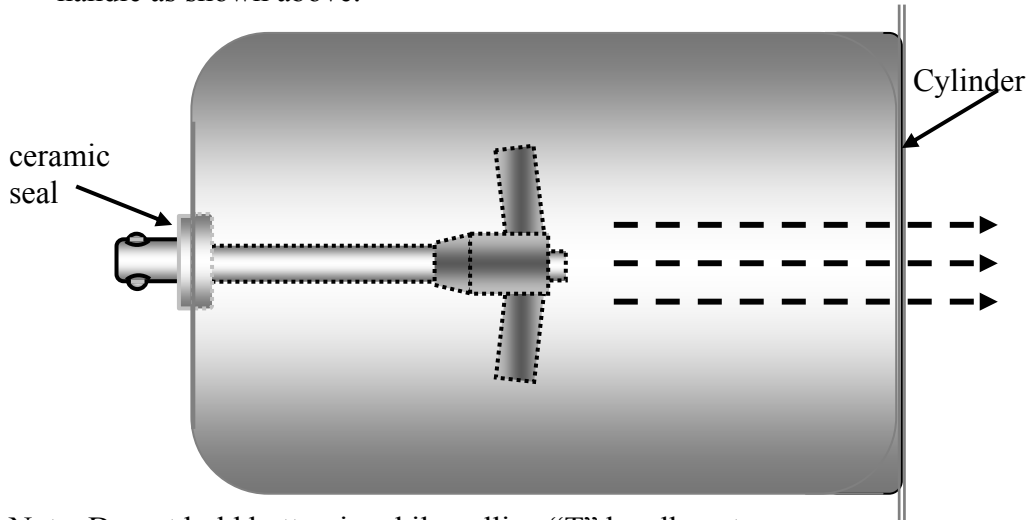

Note: Do not hold button in while pulling "T" handle out.

To install new seal:

1. Apply silicone around rear, grooved surface, of ceramic seal (Do not allow silicone to touch the smooth surface of the ceramic ring.)
2. Press seal into hole at rear of cylinder. Silicone coated surface goes in first.
3. Gently tap ceramic ring with wood or plastic rod until the seal has completely bottomed out. (The handle of a standard hammer works well if used carefully)
4. The smooth surface of the ceramic seal must be completely clean in order to provide proper sealing when the beater bar with spring seal is installed.
5. If possible allow at least four hours for silicone to cure before filling machine with product. If four hours are not available, place hair dryer 2 feet away for about 30 minutes. (Do not use the hottest setting).
6. Fill machine with product and check for leaks.
7. Machine is ready to run.

Light Box **Wire Drawing**

1. One wire from each **light end** is connected to the **starter** (one black and one white).
2. The remaining black wire at the light end is connected to one of the black wires from the ballast transformer.
3. The remaining white wire at the other light end is connected to the L2 terminal.
4. The other black wire from the ballast is connected to the Upper 3- position switch on the terminal with the blue wire. (Center post on lower row of upper switch).

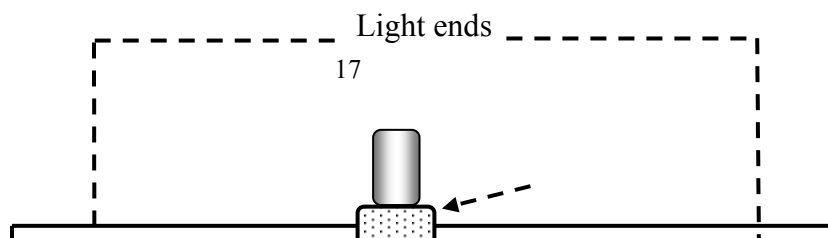

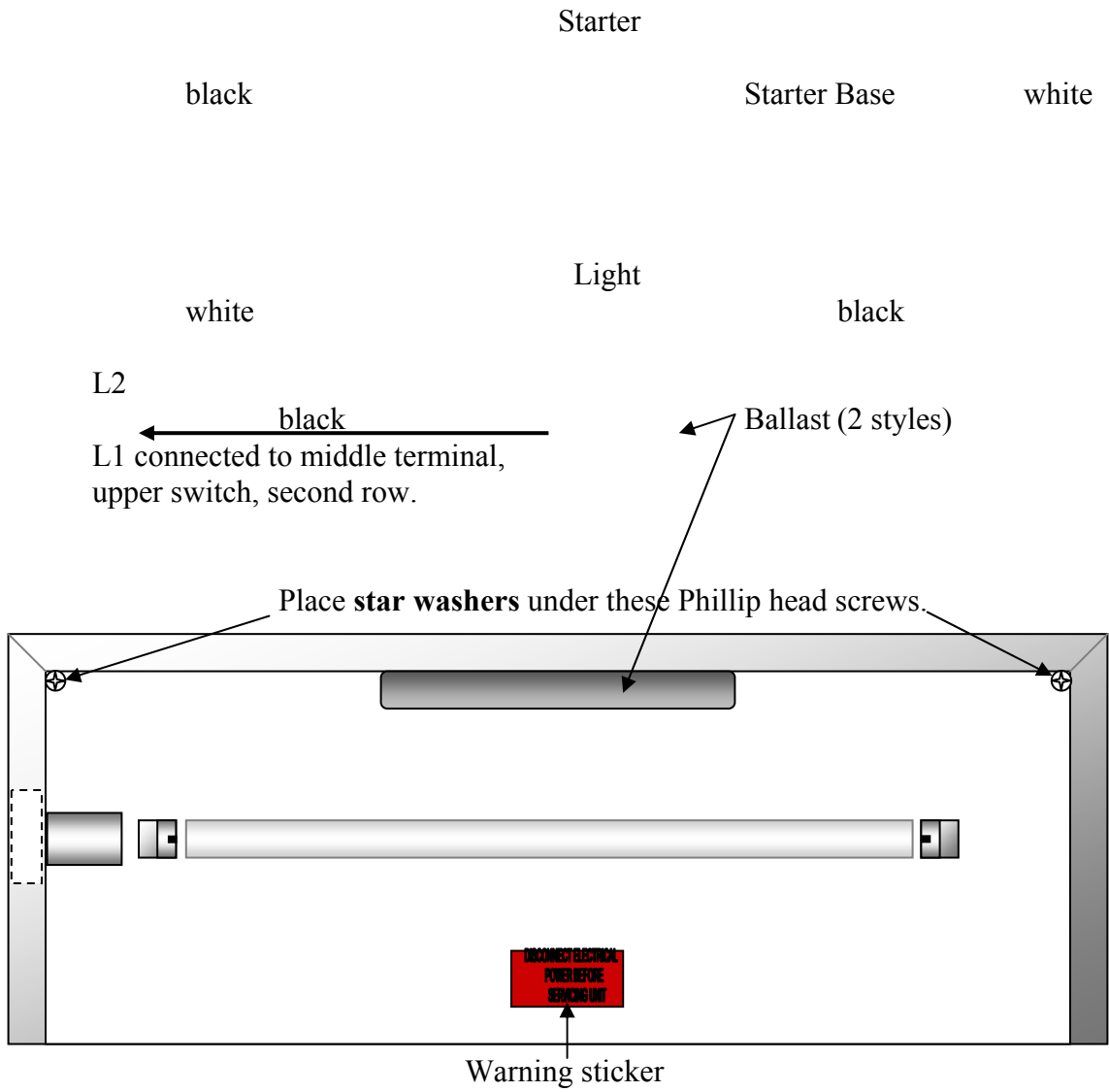

Drip Tube Brush Usage

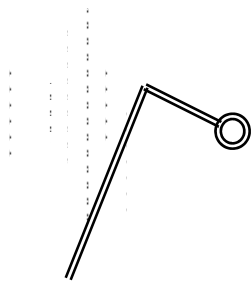

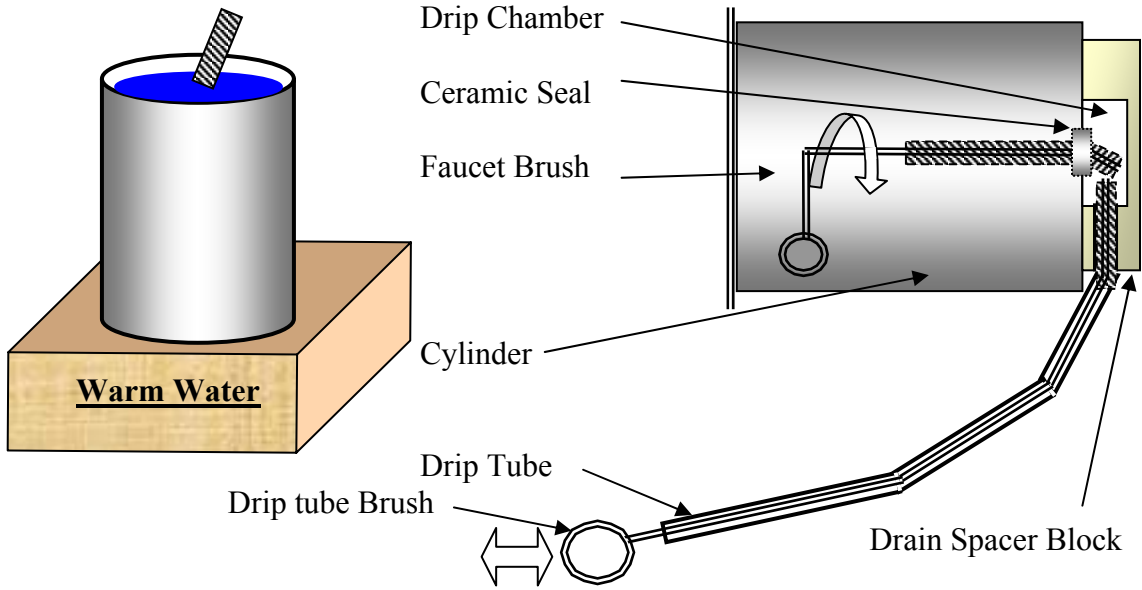

1. Dip the Faucet Brush in warm water.
2. Insert brush into the hole in the ceramic seal in the rear of the cylinder. Rotate the brush completely around to clean, as shown. Remove brush.
3. Dip the Drip Tube Brush in warm water and insert brush into drip tube.
4. Move brush back and forth to clean. Be sure the brush has been inserted completely into the Drip chamber.
5. Clean the brushes with hot soapy water when done.

Faucet Brush Usage

Use the Faucet Brush to clean the inside surfaces of the faucet as well as the inside of the ceramic seal in the cylinder.

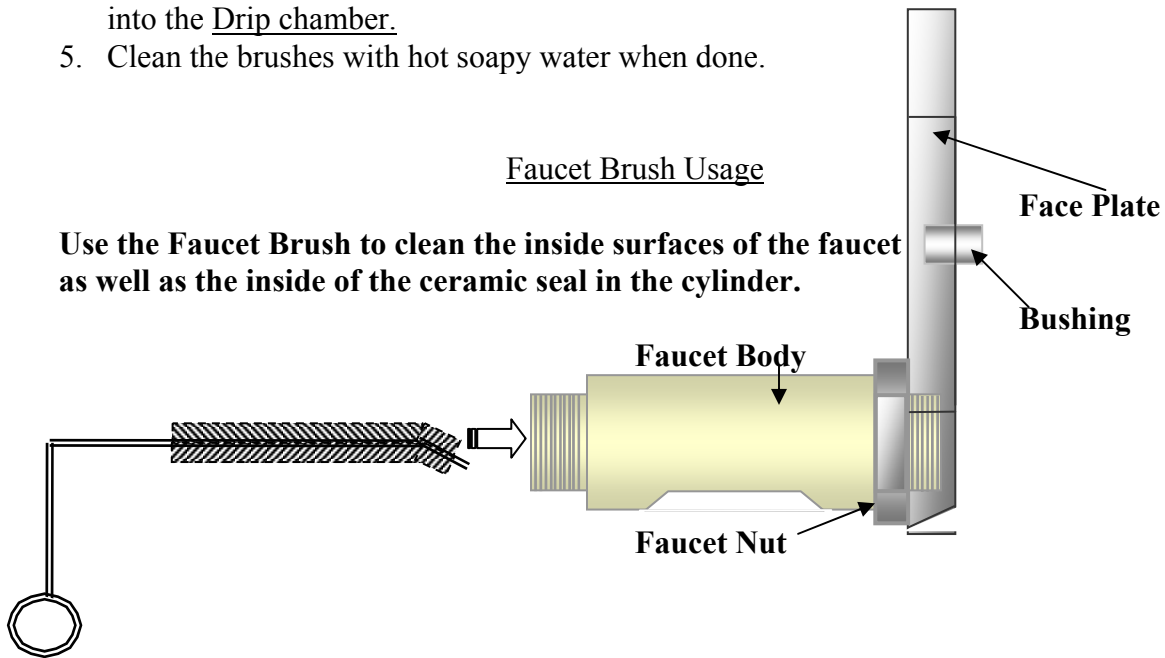

REAR CYLINDER ASSEMBLY

SORBETEER

Model Numbers; 137, 231, 232, 235R

Hopper

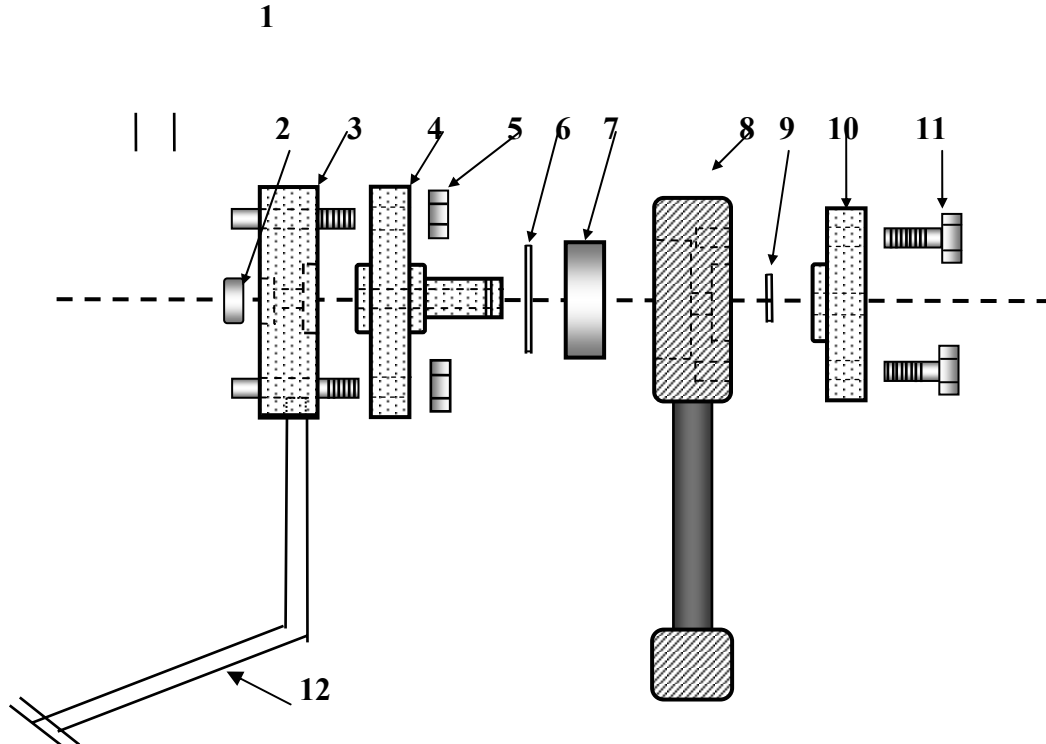

ITEM NUMBER	DESCRIPTION
1. F0811	Fill Light Switch
2. F0355 *	Ceramic Seal *
3. C2308	Drain Spacer Block
4. C2306	Bearing Plate
5. F0439	Bearing Plate Nuts 5/16x18
6. F0330	Large Clip Ring
7. F0267	Flywheel Bearing
8. F6525	Flywheel
9. F0331	Small Clip Ring
10. C4403	Drive Plate
11. F0236	Drive Plate Bolts 5/16x18x1"
12. F2309	1/2" Drain Tube(stainless steel)

***Note:** F0355 is the part number for the Spring Seal Assembly which includes the ceramic seal (No.2 above)

TORQUE CONSISTENCY CONTROL
SORBETEER MODELS

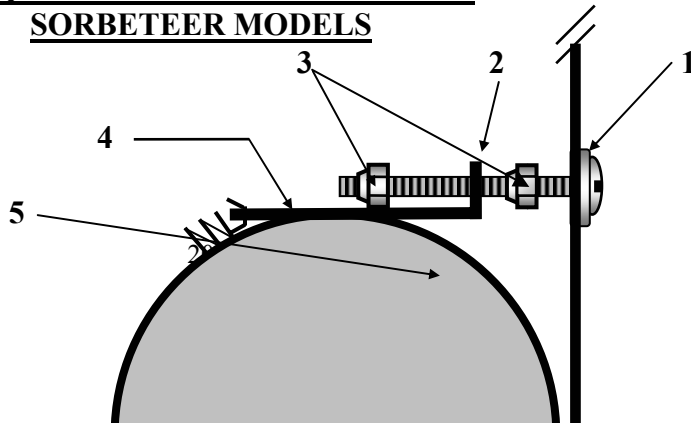

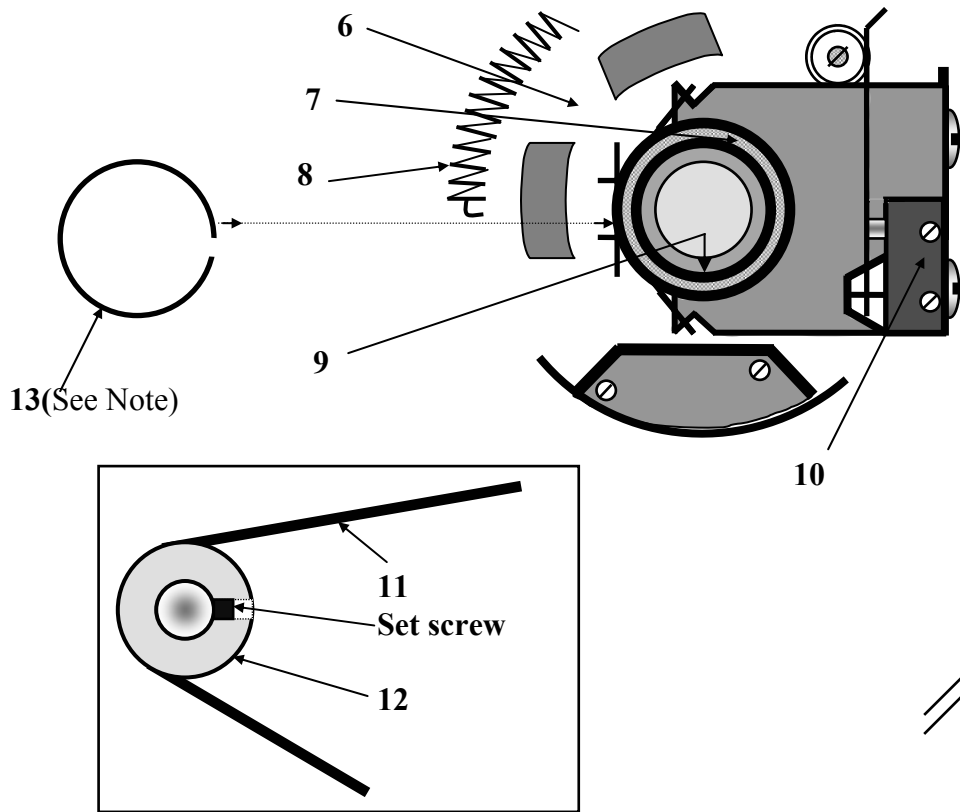

ITEM NUMBER	DESCRIPTION
1. F0443	Washer, flat 5/16"
2. F0440	Tension Adjustment Screw
3. F0441	Lock Nut, 1/4"
4. F4202	Adjustment Bracket
5. F6518	Micro -switch Cam
6. F5900	Drive Motor
7. F0474	Motor Bracket Bearing
8. F0469	Tension Spring
9. F0470	Rubber Band, Motor Bracket
10. F0346	Micro-switch
11. F0473	Drive Belt
12. F0471	Drive Pulley
13. F0092	Split Ring

Note: The **Split Ring** fits into the motor frame. It should be installed around the motor bearing and rubber-band prior to placing the assembly into the motor

Drive Belt System
All Sorbeteer Models

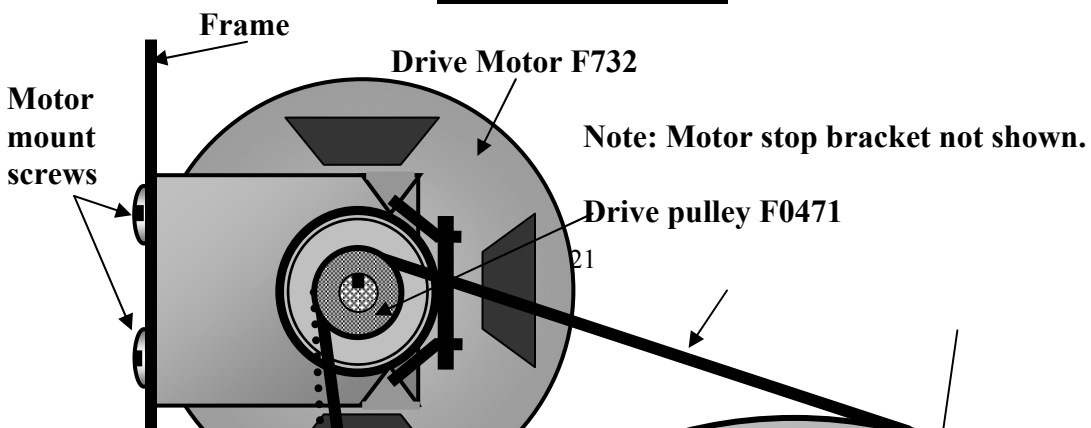

Belt F0473

Flywheel F2119

1/2"

1.

- To increase belt tension, loosen the 4 motor mount screws and pry the entire motor assembly *up* until the belt is snug. Re-tighten the motor mount screws.
2. To test the belt tension, press on the belt at the mid-point (arrow). The belt should move easily for the first 1/2 inch. It should be difficult to press the belt more than 1/2 inch.
 3. To align the drive pulley with the flywheel, loosen the Allen screw on the drive pulley and nudge the pulley forward or back as necessary.

Model 232W
Wire Diagram

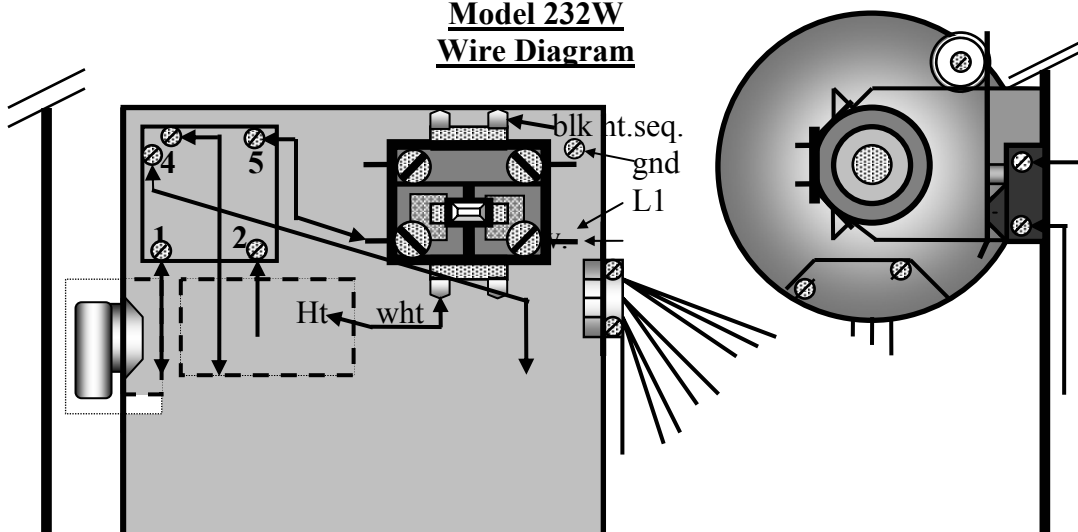

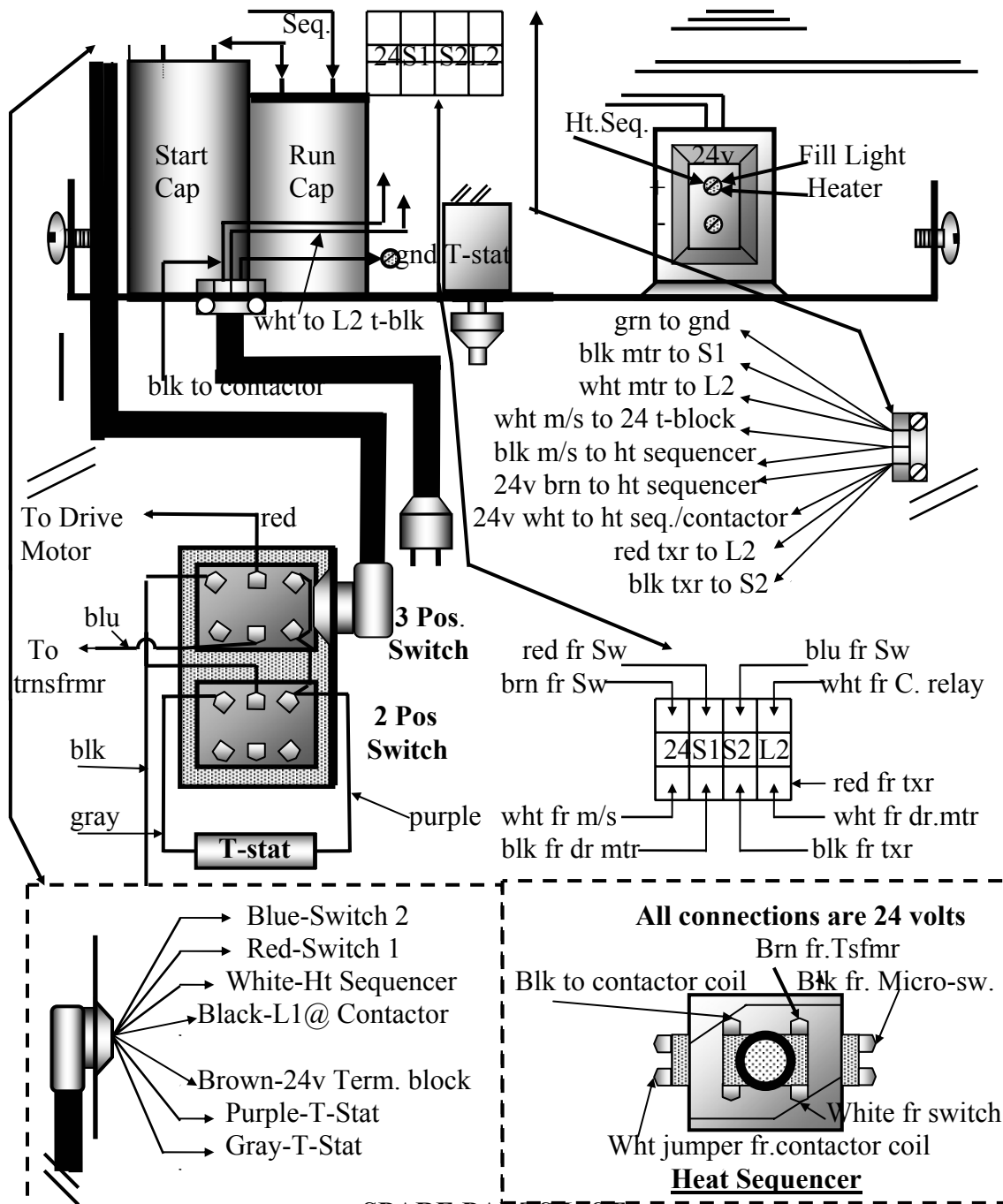

SPARE PARTS LIST
SORBETEER MODEL NO. 232W

<u>DESCRIPTION</u>	<u>ITEM NUMBER</u>
Compressor, 2 H.P. 230/60/1	AH7514A-230/60
Run Capacitor	85PR370E57
Start Capacitor	85PS250C19
Start Relay	820ARR3C32
Bearing Plate	C2306
Bearing, Flywheel	F0267

Bearing, Motor	F0474
Beater Bar	C6527
Beater Bar Spring Seal	F0355
Contactactor	F0478
Drain Spacer Block	C2308
Drip Tray	F0150
Drip Tray Screws	F0905
Drip Tube Brush	F0327
Drive Belt	F0473
Drive Motor	F0472
Drive Motor Assembly	F5900
Drive Motor Pulley	F0471
Drive Plate	C4403
Face Plate	C6501
Face Plate Bushing	C6520
Face Plate Knobs	F0262
Face Plate O-Ring	F0374
Faucet Assembly	C6513
Faucet Body	C6513B
Faucet Brush	F0326
Faucet Nut	F0197
Faucet Plunger	C6513P
Faucet Spring	F0564
Fill Light	F0207
Fill Light Switch	F0811
Filter-Drier	F5544
Float Clip	F0812
Flywheel	F6525
Heat Sequencer	F0400
High Pressure Switch	F5564
Hopper Cover	F0497
Large Clip Ring	F0330
Left Side Panel	F6405
Micro-switch	F0346
Motor Spring Bracket	F1239
O-Ring, Faucet	F0491
<u>DESCRIPTION</u>	<u>ITEM NUMBER</u>
O-Ring, Fill Switch	F0161
Panel Louver	F0254
Petro-Gel	F0298
Rear Cylinder Brace	F2005
Rear Panel	F6407
Relay, Time Delay	F4998
Right Side Panel	F6406
Sanitizer	F0492
Scraper Blade	C6510F

Scraper Blade Spring	F6512
Sign Panel	F0170
Small Clip Ring	F0331
Stainless Steel Legs	F0800
Switch Nut	F7003
Switch, 2-Position, Bottom	F0417
Switch, 3-Position, Top,	F0416
Tension Spring	F0469
Thermostat	F0401
Transformer	F4995
Water Condenser	F5549
Water Valve	F5545