

TABLE S104.7 - UPLIFT CONNECTIONS - 140 MPH WINDS EXP "C"

WFCM 2015 TABLE 3.2 & A3.4

CONNECTION	FRAMING SPACING (INCHES)	ROOF SPAN (FEET)	UPLIFT	ROOF SPAN (FT)	FRAMING SPACING (INCHES)	NUMBER OF 8d COMMON NAILS OR 10d BOX NAILS IN EACH END OF 1-1/4"x20 GAUGE STRAP
ROOF ASSEMBLY TO WALL ASSEMBLY; WALL ASSEMBLY TO WALL ASSEMBLY; WALL ASSEMBLY TO FOUNDATION				24	16"	4
				24	24"	6

TABLE S104.8 - SILL OR BOTTOM PLATE TO FOUNDATION CONNECTIONS RESISTING UPLIFT LOADS - 140 MPH WIND EXP "C"

WFCM 2015 TABLE 3.2C

BOTTOM PLATE TO FOUNDATION ANCHOR BOLT CONNECTION RESISTING	FOUNDATION SUPPORTING	MAXIMUM ANCHOR BOLT SPACING (INCHES)	
UPLIFT LOADS	1 - 3 STORES	8' END ZONES	INTERIOR ZONES
		30 INCHES ON CENTER	35 INCHES ON CENTER

NOTE: A MINIMUM OF ONE ANCHOR BOLT SHALL BE PROVIDED WITHIN 6 TO 12 INCHES OF EACH END OF EACH PLATE

TABLE S104.9 - BOTTOM PLATE TO FOUNDATION CONNECTIONS RESISTING SHEAR & LATERAL LOADS - ALL WINDS & ALL EXPOSURES

WFCM 2015 TABLE 3.2B

ANCHOR BOLT DIAMETER (IN)	1/2" Ø ANCHOR BOLT	5/8" Ø ANCHOR BOLT
MAXIMUM ANCHOR BOLT SPACING (INCHES)	31 INCHES	48 INCHES

TABLE S104.10 - FULL HEIGHT STUD REQUIREMENT FOR HEADERS OR WINDOW SILL PLATES IN EXTERIOR WALLS EXPOSURE B & C

WFCM 2015 TABLE 3.23C

HEADER SPAN (FEET)	WALL SPACING (INCHES)		
	12" O.C.	16" O.C.	24" O.C.
2	1	1	1
4	2	2	1
6	3	3	2
8	4	3	2

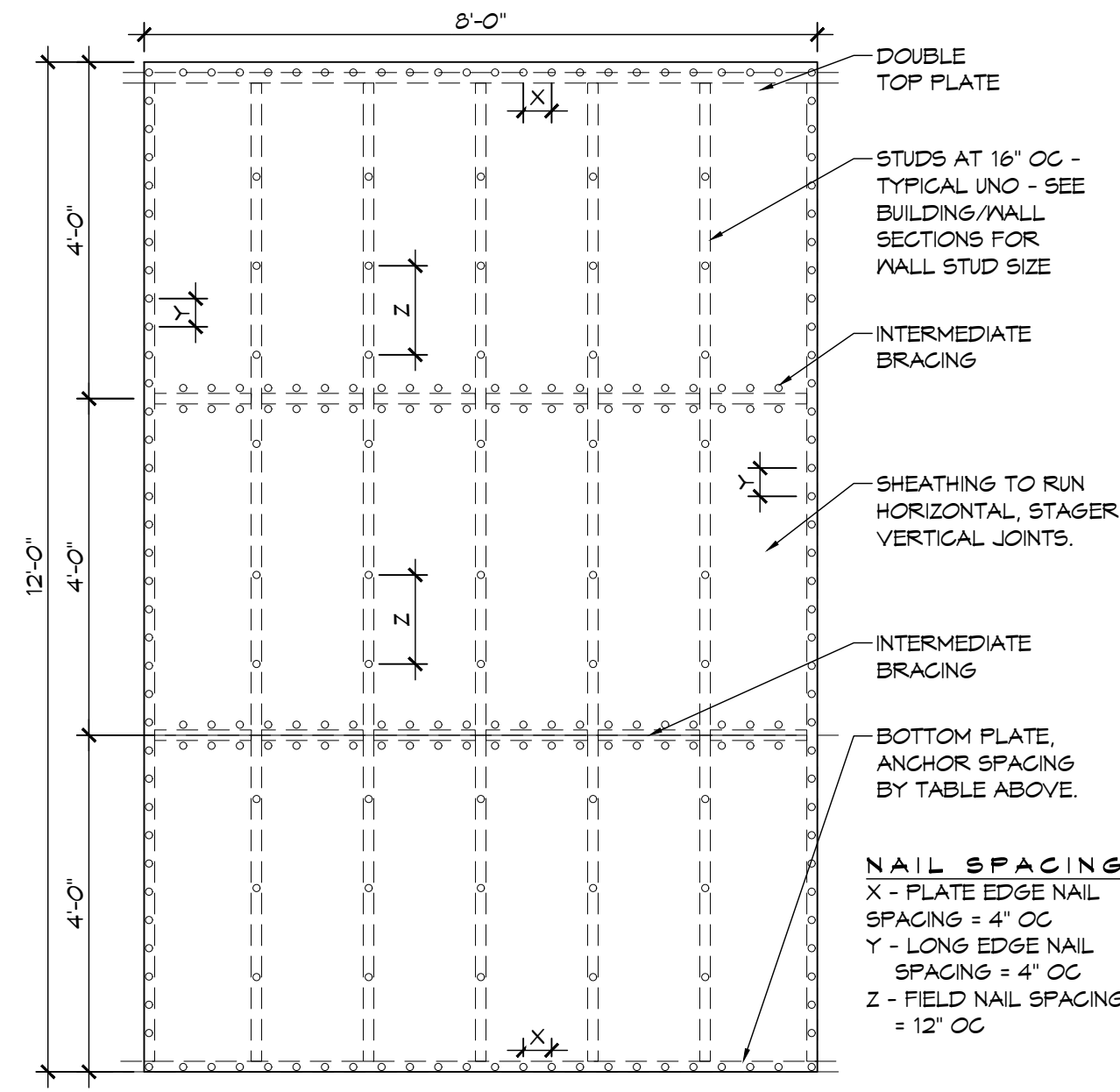

H SHEAR WALL EXTERIOR SHEATHING NAILING PATTERN

NOTE: SPACE NAILS AT EACH NAIL HOLE

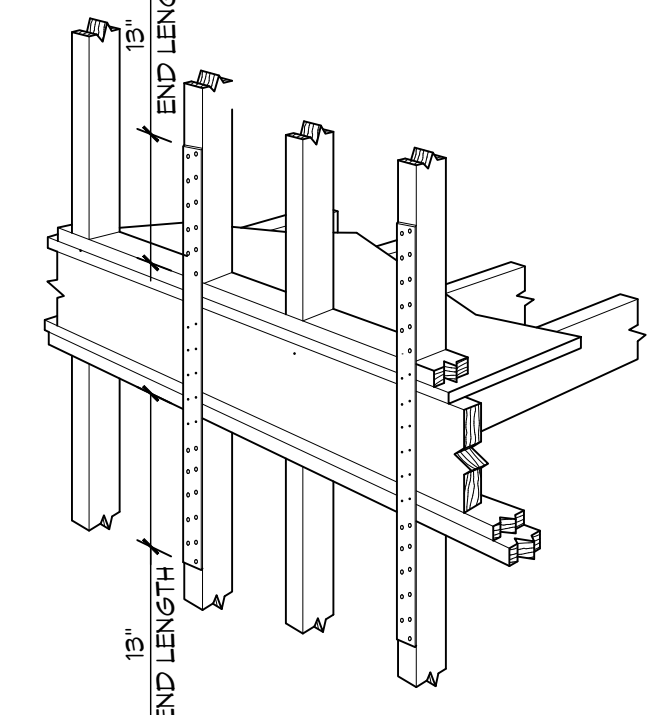

I NOT USED

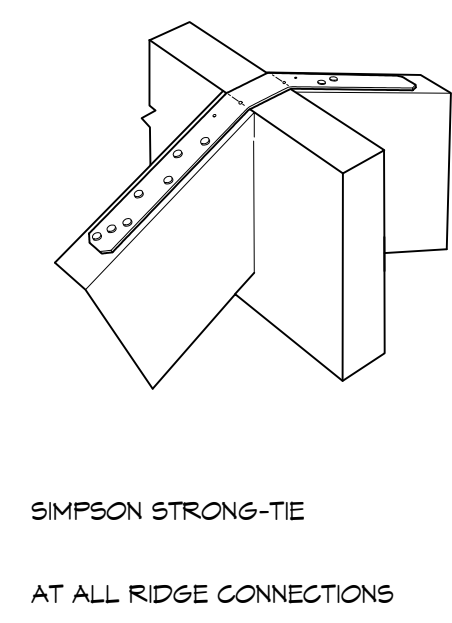

J FLOOR TO FLOOR

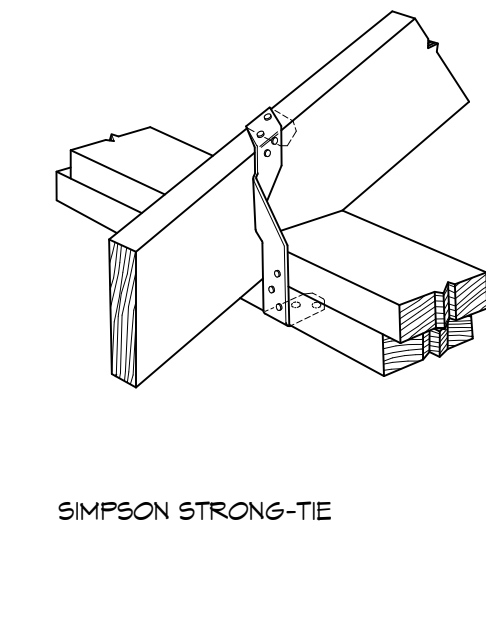

K RIDGE BEAM/BOARD

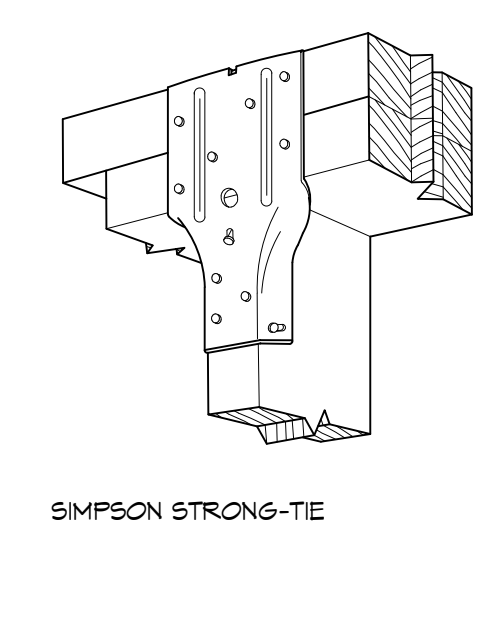

L TOP PLATE TO RAFTER

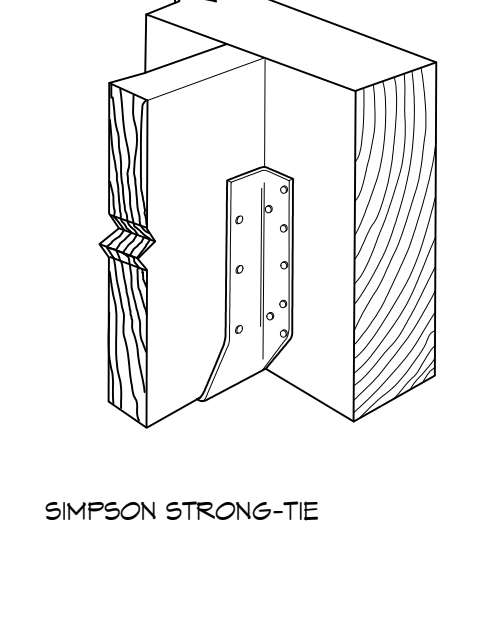

M STUD TO TOP PLATE

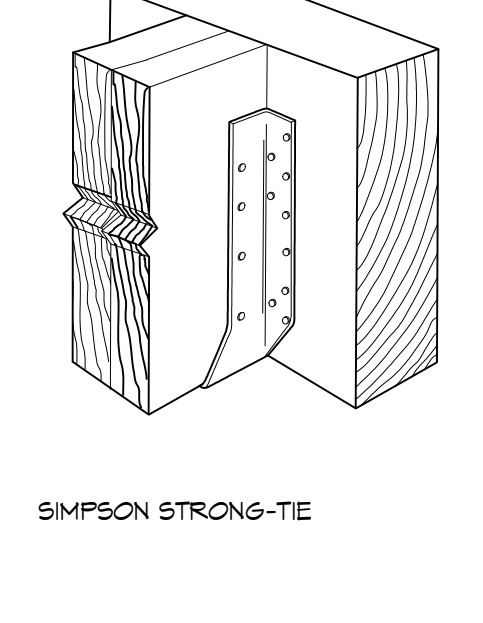

N FLOOR JOIST

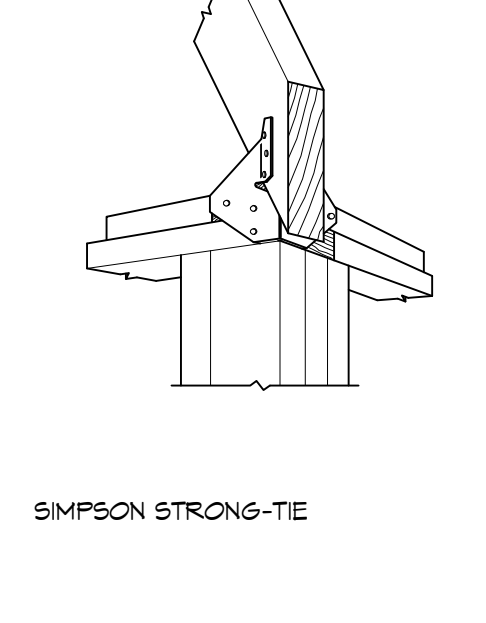

O DBL FLOOR JOIST

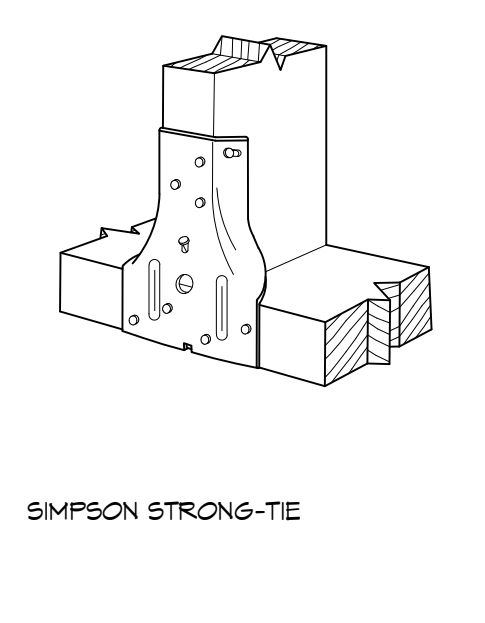

P HIP RAFTER

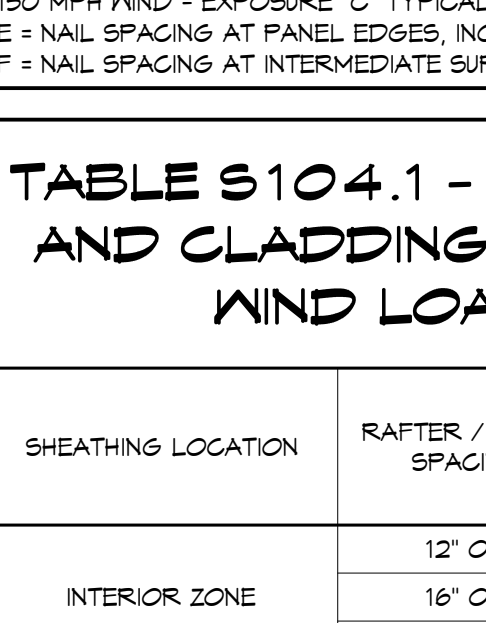

Q STUD TO BILL PLATE

6 TYPICAL CONNECTION DETAILS

TABLE S104.5 - JACK STUD REQ - INT LOADBEARING WALLS

WFCM 2015 TABLE 3.22F

HEADER SUPPORTING	HEADER SPAN (FT)	ROOF SPAN (FEET)											
		12 FEET				24 FEET				36 FEET			
		3"	4.5"	5"	6.5"	3"	4.5"	5"	6.5"	3"	4.5"	5"	6"
ONE FLOOR ONLY (CENTER BEARING)	2	1	1	1	1	1	1	1	1	1	1	1	1
	4	1	1	1	1	1	1	1	1	1	1	1	1
	6	1	1	1	1	1	1	1	1	2	1	1	1
	8	1	1	1	1	2	1	1	1	2	2	2	1
	10	1	1	1	1	2	2	1	1	3	2	2	2
	12	1	1	1	1	2	2	2	1	3	2	2	2
TWO FLOORS (CENTER BEARING)	2	1	1	1	1	1	1	1	1	2	1	1	1
	4	1	1	1	1	2	1	1	1	3	2	2	2
	6	2	1	1	1	3	2	2	2	4	3	2	2
	8	2	2	1	1	3	2	2	2	5	3	3	3
	10	2	2	2	1	4	3	3	2	6	4	4	3
	12	3	2	2	2	5	3	3	3	7	5	4	4
ROOF AND CEILING	2	1	1	1	1	1	1	1	1	1	1	1	1
	4	1	1	1	1	1	1	1	1	1	1	1	1
	6	2	1	1	1	1	2	1	1	1	1	1	1
	8	2	2	2	2	1	2	2	2	2	2	2	1
	10	3	2	2	2	2	3	2	2	2	2	2	2
	12	3	2	2	2	2	3	2	2	2	2	2	2

TABLE S104.6 - JACK STUD REQ - EXTERIOR LOADBEARING WALLS

WFCM 2015 TABLE 3.22F

HEADER SUPPORTING	HEADER SPAN (FT)	ROOF LIVE LOAD 30 PSF											
		3"				4.5"				5"			
		3"	4.5"	5"	6.5"	3"	4.5"	5"	6.5"	3"	4.5"	5"	6.5"
ROOF AND CEILING	2	1	1	1	1	1	1	1	1	1	1	1	1
	4	1	1	1	1	1	1	1	1	1	1	1	1
	6	2	1	1	1	1	2	1	1	1	1	1	1
	8	2	2	2	2	1	2	2	2	2	2	2	1
	10	3	2	2	2	2	3	2	2	2	2	2	2
	12	3	2	2	2	2	3	2	2	2	2	2	2
ROOF, CEILING, AND ONE CENTER BEARING FLOOR	2	1	1	1	1	1	1	1	1	1	1	1	1
	4	2	1	1	1	1	2	1	1	1	1	1	1
	6	2	2	2	2	1	3	2	2	2	2	2	2
	8	3	2	2	2	2	3	2	2	2	2	2	2
	10	4	3	2	2	2	4	3	3	3	2	2	2
	12	4	3	3	2	5	3	3	3	3	3	3	3

TABLE S104.3 - NAILING SCHEDULE WFCM 2015 TABLE 3.1

DESCRIPTION	NUMBER OF COMMON NAILS	NUMBER OF BOX NAILS	SPACING
HEADER TO HEADER (FACE NAILED)	16d	16d	16" OC EDGES

TABLE S104.4 - BUILDING ENVELOPE REQUIREMENTS

ROOFS	OPAQUE ELEMENTS	ASSEMBLY MAXIMUM	INSULATION MIN. R-VALUE
INSULATION ENTIRELY ABOVE DECK	U-0.040	R-20.0 c.i.	
METAL BUILDING	U-0.065	R-19	
ATTIC AND OTHER	U-0.021	R-30	
MASS	U-0.151	R-5.7 c.i.	
METAL BUILDING	U-0.113	R-13.0	
STEEL-FRAMED	U-0.124	R-13.0	
WOOD-FRAMED AND OTHER	U-0.089	R-13.0	
MASS	U-0.107	R-6.3 c.i.	
STEEL JOIST	U-0.052	R-19.0	
WOOD FRAMED AND OTHER	U-0.051	R-19.0	
UN-HEATED	F-0.730	NR	
SWINGING	U-0.700	NR	
NON-SWINGING	U-1.450	NR	

TABLE S104.4 - BUILDING ENVELOPE REQUIREMENTS

ROOFS	OPAQUE ELEMENTS	ASSEMBLY MAXIMUM	INSULATION MIN. R-VALUE
INSULATION ENTIRELY ABOVE DECK	U-0.040	R-20.0 c.i.	
METAL BUILDING	U-0.065	R-19	
ATTIC AND OTHER	U-0.021	R-30	
MASS	U-0.151	R-5.7 c.i.	
METAL BUILDING	U-0.113	R-13.0	
STEEL-FRAMED	U-0.124	R-13.0	
WOOD-FRAMED AND OTHER	U-0.089	R-13.0	
MASS	U-0.107	R-6.3 c.i.	
STEEL JOIST	U-0.052	R-19.0	
WOOD FRAMED AND OTHER	U-0.051	R-19.0	
UN-HEATED	F-0.730	NR	
SWINGING	U-0.700	NR	
NON-SWINGING	U-1.450	NR	

TABLE S104.1 - ROOF SHEATHING ATTACHMENT REQUIREMENT - WIND LOAD EXP "C"

SHEATHING LOCATION	RAFTER / TRUSS SPACING	MAX NAIL SPACING FOR 8d COMMON NAILS OR 10d BOX NAILS (INCHES OC)	
		E	F
INTERIOR ZONE	12" OC	6	12
	16" OC	6	12
	24" OC	6	12
PERIMETER EDGE ZONE	12" OC	6	6
	16" OC	4	4
	24" OC	3	3

TABLE S104.1 - WALL SHEATHING AND CLADDING REQUIREMENT - WIND LOAD EXP "C"

SHEATHING LOCATION	RAFTER / TRUSS SPACING	MAX NAIL SPACING FOR 8d COMMON NAILS OR 10d BOX NAILS (INCHES OC)	
		E	F
INTERIOR ZONE	12" OC	6	12
	16" OC	6	12
	24" OC	6	6
PERIMETER EDGE ZONE	12" OC	6	12
	16" OC	6	12
	24" OC	6	6

ROOF UNDERLAYMENT NOTES

1. FOR ROOF SLOPES FROM TWO UNITS VERTICAL IN 12 UNITS HORIZONTAL (17-PERCENT SLOPE), UP TO FOUR UNITS VERTICAL IN 12 UNITS HORIZONTAL (33-PERCENT SLOPE), UNDERLAYMENT SHALL BE TWO LAYERS APPLIED IN THE FOLLOWING MANNER:
 a. APPLY A 19 INCH STRIP OF UNDERLAYMENT FELT PARALLEL WITH AND STARTING AT THE EAVES, FASTENED SUFFICIENTLY TO HOLD IN PLACE. STARTING AT THE EAVES, APPLY 36 INCH WIDE SHEETS OF UNDERLAYMENT OVERLAPPING SUCCESSIVE SHEETS 19 INCHES, AND FASTENED SUFFICIENTLY TO HOLD IN PLACE.

SHINGLE APPLICATION & FASTENING NOTES

1. ASPHALT STRIP SHINGLES SHALL HAVE A MINIMUM OF SIX FASTENERS PER SHINGLE WHERE THE ROOF IS IN ONE OF THE FOLLOWING CATEGORIES:
 a. THE BASIC WIND SPEED IS 110 MPH OR GREATER AND THE EAVE IS 20 FEET OR HIGHER ABOVE GRADE.
 b. UNDERLAYMENT SHALL BE APPLIED SHINGLE FASHION, PARALLEL TO AND STARTING FROM THE EAVE AND LAPPED 2 INCHES, FASTENED SUFFICIENTLY TO HOLD IN PLACE. END LAPS SHALL BE OFFSET BY 6 FEET.
 c. SPECIAL WIND ZONES.

METAL ROOF APPLICATION & FASTENING NOTES

1. INSTALL METAL ROOF PER MANUFACTURERS RECOMMENDATIONS FOR 150MPH WIND SPEED.

GENERAL UPLIFT CONNECTION NOTES

ROOF ASSEMBLY TO WALL ASSEMBLY: UPLIFT CONNECTIONS SHALL BE FROM RAFTER OR TRUSS TO WALL STUD. WHEN RAFTERS OR TRUSSES ARE NOT LOCATED DIRECTLY ABOVE STUDS, RAFTERS SHALL BE ATTACHED TO THE WALL PLATE AND THE WALL TOP PLATE SHALL BE ATTACHED TO THE WALL STUD WITH UPLIFT CONNECTIONS. UPLIFT CONNECTIONS SHALL BE IN ACCORDANCE WITH TABLE S104.10.

WALL ASSEMBLY TO WALL ASSEMBLY: STORY TO STORY UPLIFT CONNECTIONS FROM UPPER STORY WALL STUD TO LOWER STORY WALL STUD. WHEN UPPER STORY WALL STUDS ARE NOT LOCATED DIRECTLY ABOVE LOWER WALL STUDS, THE STUDS SHALL BE ATTACHED TO A COMMON MEMBER IN THE FLOOR ASSEMBLY BY UPLIFT CONNECTIONS. UPLIFT CONNECTIONS SHALL BE IN ACCORDANCE WITH TABLE S104.11.

WALL ASSEMBLY TO FOUNDATION: FIRST FLOOR WALL STUDS SHALL BE CONNECTED TO THE FOUNDATION, SILL, PLATE, OR BOTTOM PLATE. A MINIMUM OF A 1-1/4" x 20 GA. ASTM A689 GRADE 33 STEEL STRAP SHALL BE NAILED TO THE WALL STUDS AND HAVE A MINIMUM EMBEDMENT OF 1 INCHES IN CONCRETE FOUNDATIONS AND SLABS-ON-GRADE, 15 INCHES IN MASONRY BLOCK FOUNDATIONS, OR BE LAPPED UNDER THE BOTTOM PLATE. 3 INCH SQUARE WASHERS SHALL BE USED ON THE ANCHOR BOLTS AND ANCHOR BOLT SPACINGS SHALL NOT EXCEED THE REQUIREMENTS. STEEL STRAPS EMBEDDED IN OR IN CONTACT WITH SLAB-ON-GRADE OR MASONRY BLOCK FOUNDATIONS SHALL BE HOT-DIPPED GALV. AFTER FABRICATION, OR MANUF. FROM G185 OR Z450 GALV. STL. CONNECTIONS SHALL BE IN ACCORDANCE WITH TABLE S104.12.

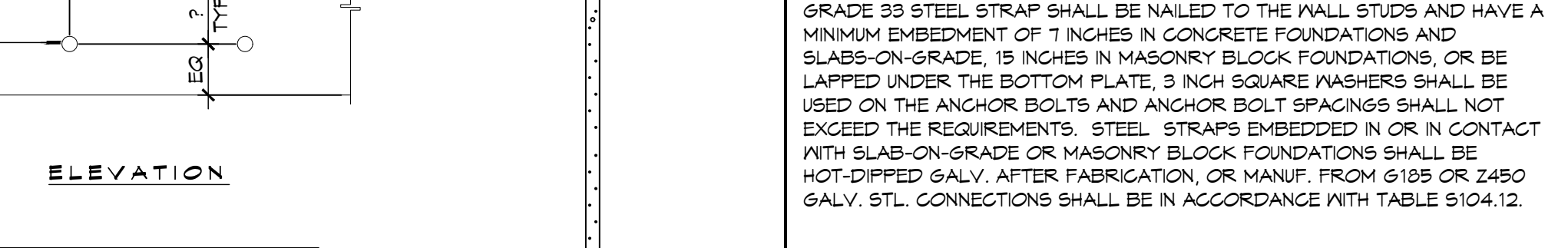

TABLE S104.1 - ROOF SHEATHING ATTACHMENT REQUIREMENT - WIND LOAD EXP "C"

SHEATHING LOCATION	RAFTER / TRUSS SPACING	MAX NAIL SPACING FOR 8d COMMON NAILS OR 10d BOX NAILS (INCHES OC)	
		E	F
INTERIOR ZONE	12" OC	6	12
	16" OC	6	12
	24" OC	6	12
PERIMETER EDGE ZONE	12" OC	6	6
	16" OC	4	4
	24" OC	3	3

TABLE S104.1 - WALL SHEATHING AND CLADDING REQUIREMENT - WIND LOAD EXP "C"

SHEATHING LOCATION	RAFTER / TRUSS SPACING	MAX NAIL SPACING FOR 8d COMMON NAILS OR 10d BOX NAILS (INCHES OC)	
		E	F
INTERIOR ZONE	12" OC	6	12
	16" OC	6	12
	24" OC	6	6
PERIMETER EDGE ZONE	12" OC	6	12
	16" OC	6	12
	24" OC	6	6

TABLE S104.1 - WALL SHEATHING AND CLADDING REQUIREMENT - WIND LOAD EXP "C"

SHEATHING LOCATION	RAFTER / TRUSS SPACING	MAX NAIL SPACING FOR 8d COMMON NAILS OR 10d BOX NAILS (INCHES OC)	
		E	F
INTERIOR ZONE	12" OC	6	12
	16" OC	6	12
	24" OC	6	6
PERIMETER EDGE ZONE	12" OC	6	12
	16" OC	6	12
	24" OC	6	6

TABLE S104.1 - WALL SHEATHING AND CLADDING REQUIREMENT - WIND LOAD EXP "C"

SHEATHING LOCATION	RAFTER / TRUSS SPACING	MAX NAIL SPACING FOR 8d COMMON NAILS OR 10d BOX NAILS (INCHES OC)	
		E	F
INTERIOR ZONE	12" OC	6	12
	16" OC	6	12
	24" OC	6	6
PERIMETER EDGE ZONE	12" OC	6	12
	16" OC	6	12
	24" OC	6	6

DAMMON ENGINEERING, INC.
 LOUISIANA & MISSISSIPPI
 Chief Engineer: Brian Mistich, PE
 554 Old Spanish Trail
 Slidell, LA 70688
 www.dammonengineering.com
 info@dammonengineering.com
 PH: 985.649.5832 F: 985.641.5950

DATE: _____
 REVISIONS: _____
 # DESCRIPTION: _____
 SEAL: _____

STATE OF LOUISIANA
 BRIAN A. MISTICH
 LICENSE NO. 33817
 11/18/2022

NEW HOTEL FOR
 AZULE
 150 BEACH BOULEVARD, U.S. HWY. 90
 BLOOMINGVILLE, MISSISSIPPI 39500
 JOB No: 2251 DATE: 10-11-2024
 DRAWN BY: JTL CHECKED BY: JTL

SHEET TITLE:
 TYPICAL CONNECTION
 DETAILS, SCHEDULES, AND
 NOTES

DRAWING NUMBER:
S104

SHEET No: 9 of 53