

## SECURITRON PB5 EXIT BUTTON INSTALLATION AND OPERATING INSTRUCTIONS

### 1. DESCRIPTION

The model PB5 is a spring loaded momentary 2" diameter, illuminated exit button, mounted on a stainless steel single gang outlet box cover. The DPST contacts switch when the button is depressed and return when it is released. The contacts are UL listed with 10 AMP capacity. The PB5 can be used for momentary release of fail safe or fail secure electric locks. It may also be used to input a REX (request to exit) signal to a card reader system for release of an electric lock. We recommend that the local building or fire safety authority be consulted prior to using exit buttons for door egress. They may require a "no special knowledge" exit device such as Securitron's Touch Sense Bar.

### 2. INSTALLATION

The PB5 comes with a retrofit backbox and color coded hookup wires installed. The backbox (Securitron part number 560-10200) includes an installation template. If a different box is used, be sure it is at least 2 1/2" deep to accommodate the switch. The drawing below identifies the unit's connection points.

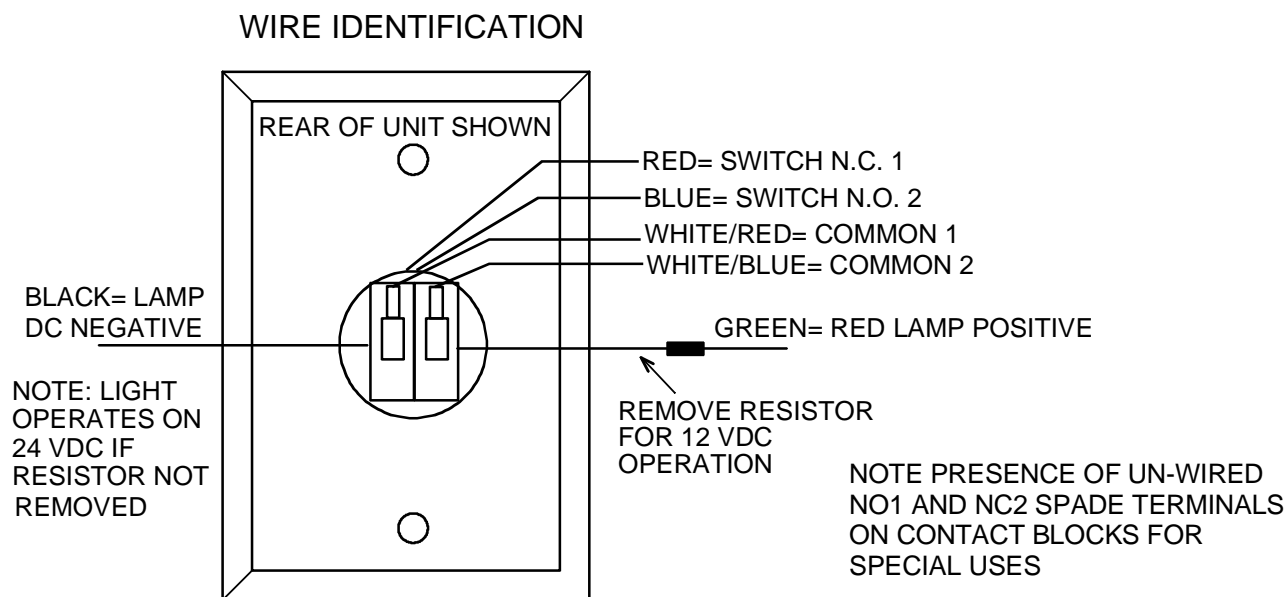

### 3. LAMP OPERATION

A resistor is installed so that the lamp may be operated on either 12 or 24 VDC. The green wire that drives the incandescent red lamp has a single resistor soldered on it. If the power supply is 24 VDC, connect directly to the wire. If the power supply is 12 VDC, remove the resistor for proper operation at the lower voltage.

The red lamp draws **80 mA** at either voltage. **Be sure you take this current into account when selecting your power supply capacity.** For replacement: the red lamp is a T 3 1/4 Wedge Base generic part # 658 or Securitron part number 030-13300. The red lamp is replaced by snapping out the contact block assembly at the rear of the switch. This reveals the lamp which is then pulled out from the block. Note that the incandescent lamp is specially selected for low current and long (25,000 hour) operating life at the expense of brightness. "Standard" T 3 1/4 lamps draw as much as 200 mA and last only 2,000 hours but are brighter.

#### 4. WIRING

The PB5 can be used in many different ways but the drawings below show two common applications. The first shows momentary release of a fail safe or fail secure electric lock. The PB5 indicator is connected so that the lamp is normally on (which helps guide a person to the push button). When the button is pressed, releasing the lock, the lamp turns off. The second drawing shows interface of the PB5 with an access control system such that a fail safe lock (generally a magnetic lock) is released for the amount of time programmed into the system in safe, double break fashion. This application uses both poles of the PB5. The NC contacts of the PB5 are connected in series with the NC contacts of the access control system's lock control relay and the NO contacts of the PB5E connect to the REX input terminals of the access control system such that when the button is pressed, the access control system will operate its relay thereby releasing the lock and allowing egress. But if the access control system experiences an electronic failure, the PB5E contacts will still directly release the fail safe lock for as long as the button is held pressed.

Note finally that for special applications, unwired contacts NO1 and NC2 can be connected for full DPDT switch operation. You will see the unwired spade terminals on each contact block.

##### MOMENTARY RELEASE OF FAIL SAFE OR FAIL SECURE ELECTRIC LOCK

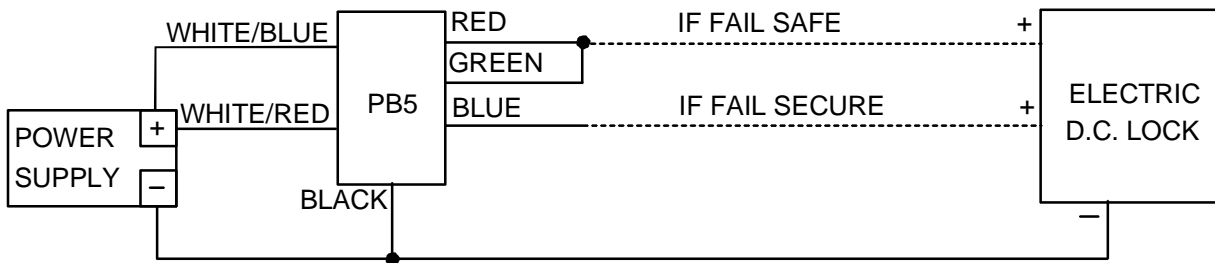

##### TIMED DOUBLE BREAK: FAIL SAFE LOCK USED WITH ACCESS SYSTEM

