



DATA RESEARCH BY AUTOMOTIVE HOBBYISTS

The enclosed research material was individually created and digitally printed for the specific customer who requested it and is intended for their exclusive, private and non-commercial use. This material is Copyright protected & is printed under license from the publisher and may not be transferred or redistributed in any way.

**Click [HERE](#) to Visit [ADOBE.COM](#)
for Viewing & Printing Tips**

AIR CONDITIONING

2.4L

[Fig. 1: 2.4L, Manual A/C Circuit](#)

2.4L TURBO

[Fig. 2: 2.4L Turbo, Manual A/C Circuit](#)

ANTI-LOCK BRAKES

[Fig. 3: Anti-lock Brakes Circuit](#)

ANTI-THEFT

[Fig. 4: Anti-theft Circuit, Convertible](#)

[Fig. 5: Anti-theft Circuit, Except Convertible](#)

COMPUTER DATA LINES

[Fig. 6: Computer Data Lines Circuit](#)

COOLING FAN

2.4L

[Fig. 7: 2.4L, Cooling Fan Circuit](#)

2.4L TURBO

[Fig. 8: 2.4L Turbo, Cooling Fan Circuit](#)

CRUISE CONTROL

[Fig. 9: Cruise Control Circuit](#)

DEFOGGERS

[Fig. 10: Defoggers Circuit](#)

ENGINE PERFORMANCE

2.4L

[Fig. 11: 2.4L, Engine Performance Circuit \(1 of 3\)](#)

[Fig. 12: 2.4L, Engine Performance Circuit \(2 of 3\)](#)

[Fig. 13: 2.4L, Engine Performance Circuit \(3 of 3\)](#)

2.4L TURBO

[Fig. 14: 2.4L Turbo, Engine Performance Circuit \(1 of 3\)](#)

[Fig. 15: 2.4L Turbo, Engine Performance Circuit \(2 of 3\)](#)

[Fig. 16: 2.4L Turbo, Engine Performance Circuit \(3 of 3\)](#)

EXTERIOR LIGHTS

[Fig. 17: Back-up Lamps Circuit](#)

[Fig. 18: Exterior Lamps Circuit](#)

GROUND DISTRIBUTION

[Fig. 19: Ground Distribution Circuit \(1 of 3\)](#)

[Fig. 20: Ground Distribution Circuit \(2 of 3\)](#)

[Fig. 21: Ground Distribution Circuit \(3 of 3\)](#)

HEADLIGHTS

[Fig. 22: Headlights Circuit](#)

HORN

[Fig. 23: Horn Circuit](#)

INSTRUMENT CLUSTER

[Fig. 24: Instrument Cluster Circuit, Convertible \(1 of 2\)](#)

[Fig. 25: Instrument Cluster Circuit, Convertible \(2 of 2\)](#)

[Fig. 26: Instrument Cluster Circuit, Except Convertible \(1 of 2\)](#)

[Fig. 27: Instrument Cluster Circuit, Except Convertible \(2 of 2\)](#)

[Fig. 28: Overhead Console Circuit, Convertible](#)

[Fig. 29: Overhead Console Circuit, Except Convertible](#)

INTERIOR LIGHTS

[Fig. 30: Interior Lights Circuit, Convertible](#)

[Fig. 31: Interior Lights Circuit, Except Convertible](#)

POWER DISTRIBUTION

[Fig. 32: Power Distribution Circuit \(1 of 2\)](#)

[Fig. 33: Power Distribution Circuit \(2 of 2\)](#)

POWER DOOR LOCKS

[Fig. 34: Power Door Locks Circuit, Convertible](#)

[Fig. 35: Power Door Locks Circuit, Except Convertible](#)

POWER MIRRORS

[Fig. 36: Power Mirrors Circuit](#)

POWER SEATS

[Fig. 37: Heated Seats Circuit](#)

[Fig. 38: Power Seat Circuit](#)

POWER TOP/SUNROOF

[Fig. 39: Convertible Top Circuit](#)

[Fig. 40: Sunroof Circuit](#)

POWER WINDOWS

[Fig. 41: Power Windows Circuit, Convertible](#)

[Fig. 42: Power Windows Circuit, Except Convertible](#)

RADIO

[Fig. 43: Radio Circuit, Convertible Base Radio W/ Hands Free](#)

[Fig. 44: Radio Circuit, Convertible Base Radio W/O Hands Free](#)

[Fig. 45: Radio Circuit, Convertible Premium Radio W/ Hands Free \(1 of 2\)](#)

[Fig. 46: Radio Circuit, Convertible Premium Radio W/ Hands Free \(2 of 2\)](#)

[Fig. 47: Radio Circuit, Convertible Premium Radio W/O Hands Free](#)

[Fig. 48: Radio Circuit, Except Convertible W/ Hands Free](#)

[Fig. 49: Radio Circuit, Except Convertible W/O Hands Free](#)

SHIFT INTERLOCK

[Fig. 50: Shift Interlock Circuit](#)

STARTING/CHARGING

[Fig. 51: Charging Circuit](#)

[Fig. 52: Starting Circuit](#)

SUPPLEMENTAL RESTRAINTS

[Fig. 53: Supplemental Restraints Circuit, Base](#)

[Fig. 54: Supplemental Restraints Circuit, Premium](#)

TRANSMISSION

2.4L

[Fig. 55: 2.4L, A/T Circuit \(1 of 2\)](#)

[Fig. 56: 2.4L, A/T Circuit \(2 of 2\)](#)

2.4L TURBO

[Fig. 57: 2.4L Turbo, A/T Circuit \(1 of 2\)](#)

[Fig. 58: 2.4L Turbo, A/T Circuit \(2 of 2\)](#)

TRUNK, TAILGATE, FUEL DOOR

[Fig. 59: Liftgate Release Circuit, Except Convertible](#)

WARNING SYSTEMS

[Fig. 60: Warning Systems Circuit](#)

WIPER/WASHER

[Fig. 61: Wiper/Washer Circuit](#)

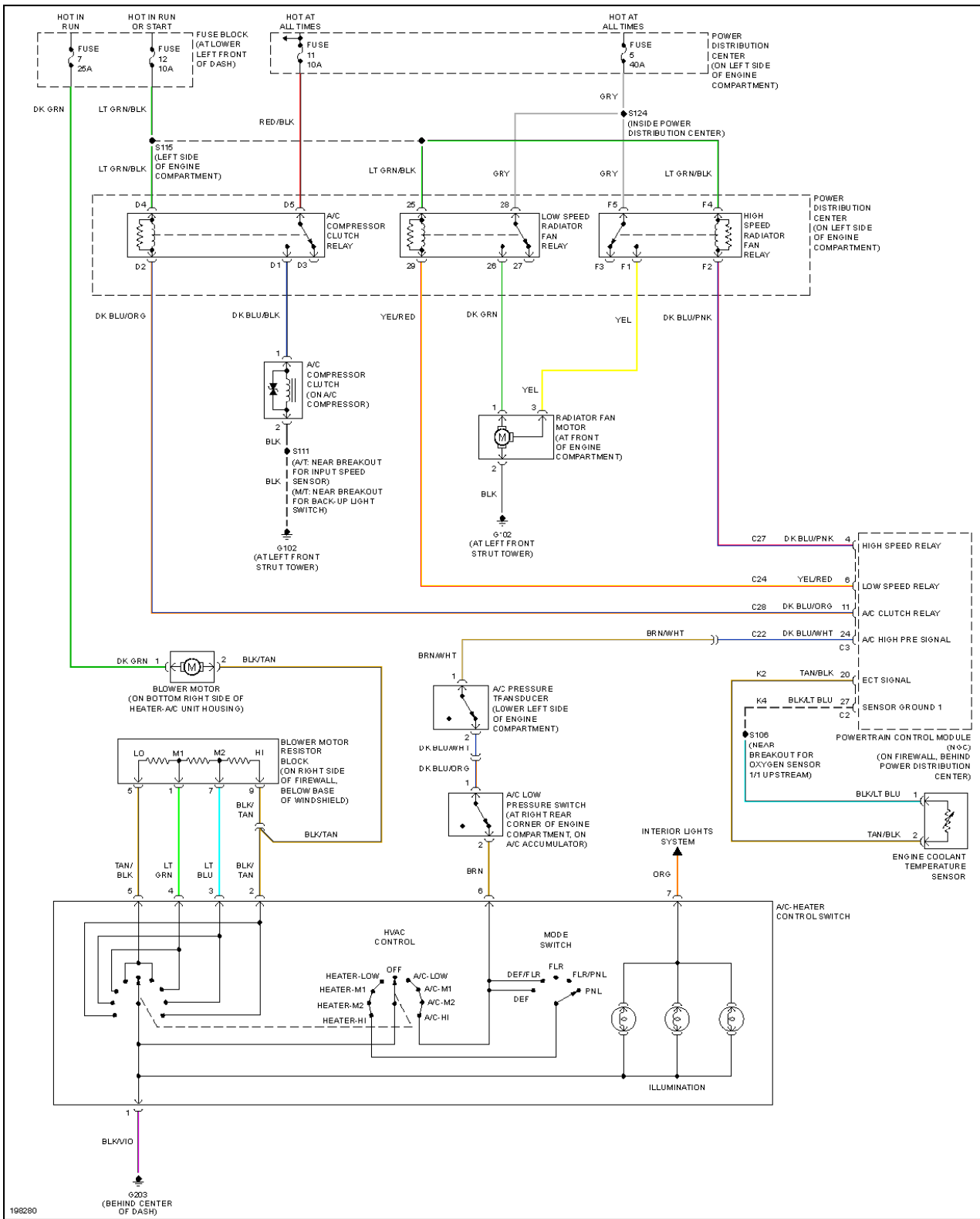

Fig. 1: 2.4L, Manual A/C Circuit

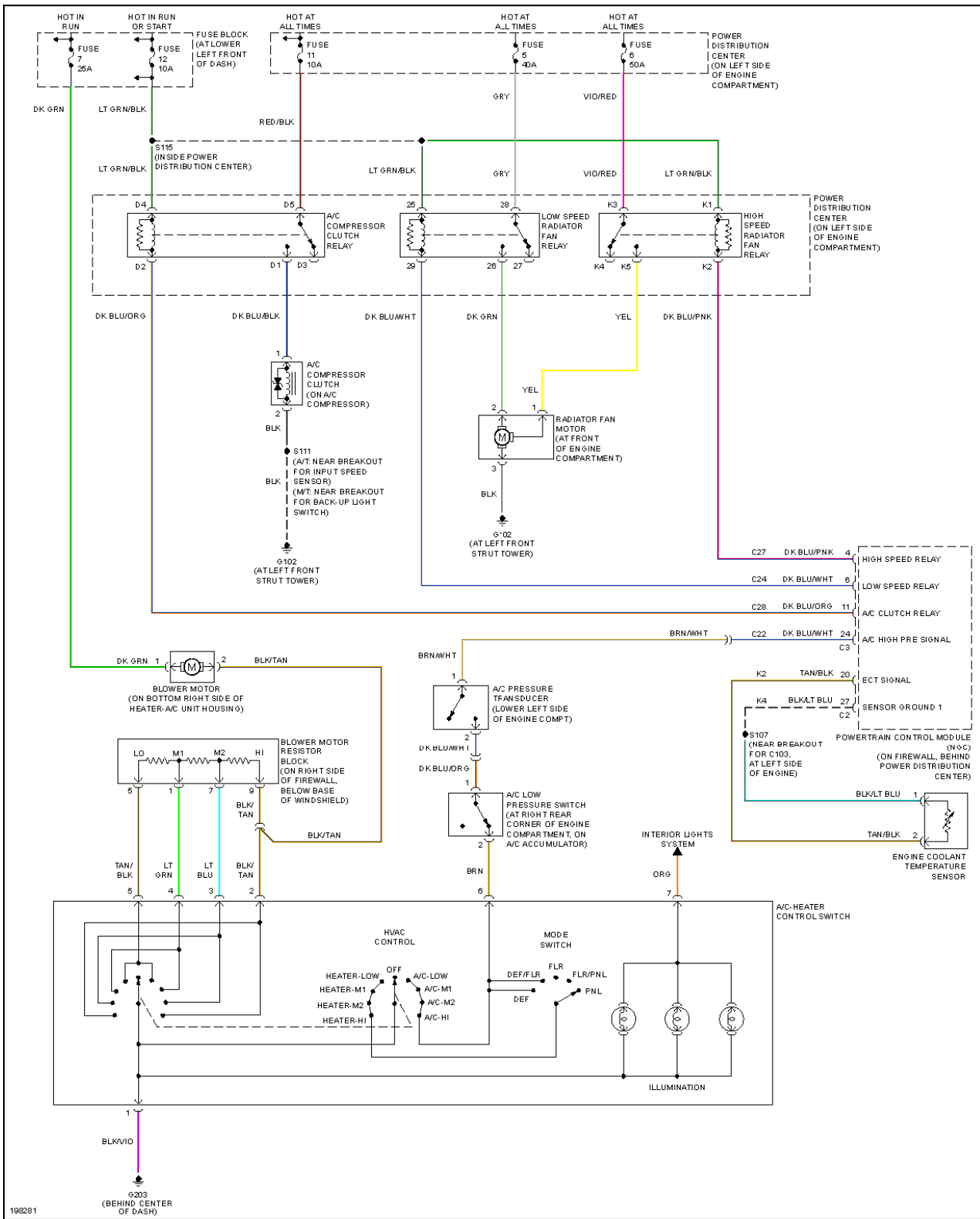

Fig. 2: 2.4L Turbo, Manual A/C Circuit

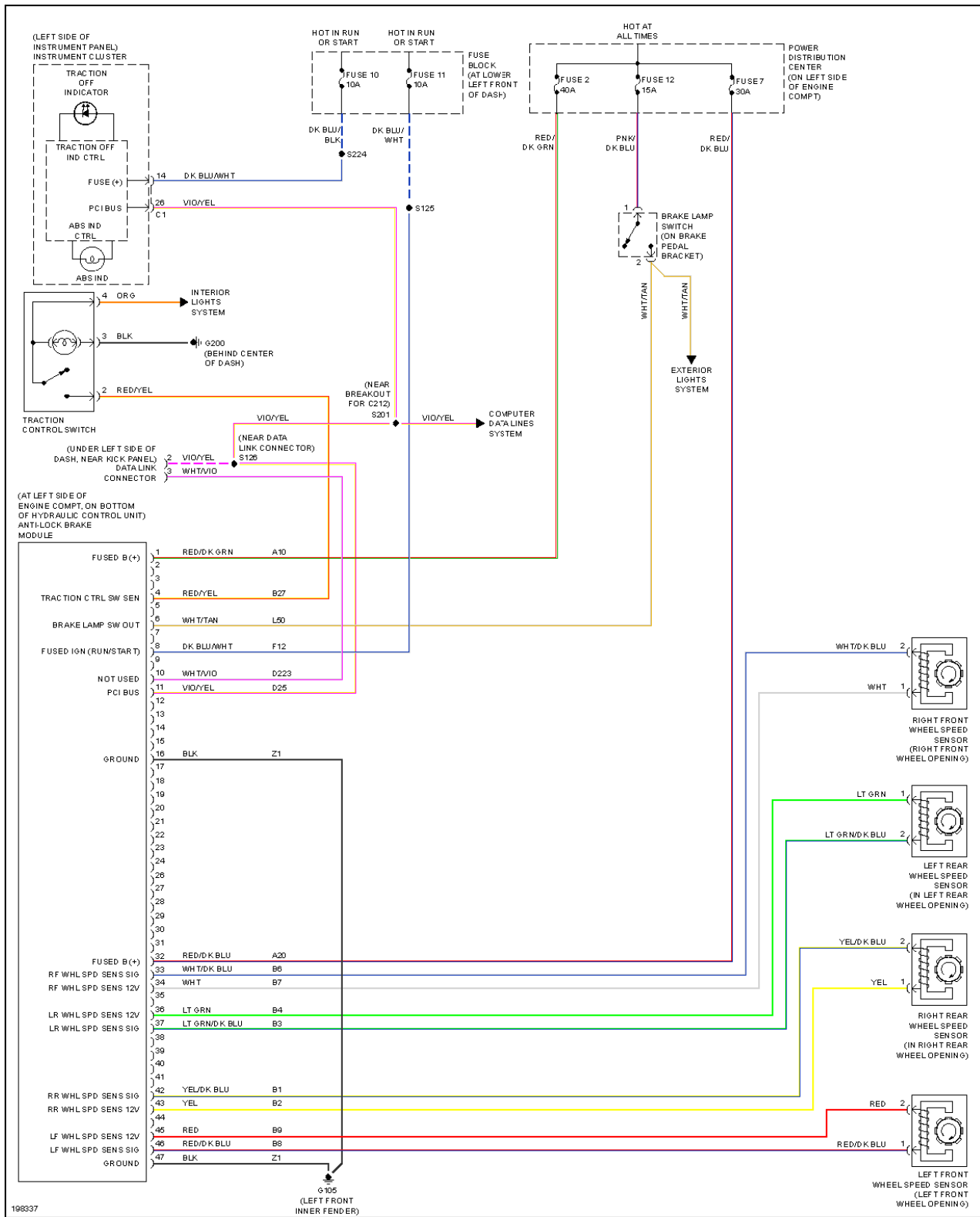

Fig. 3: Anti-lock Brakes Circuit

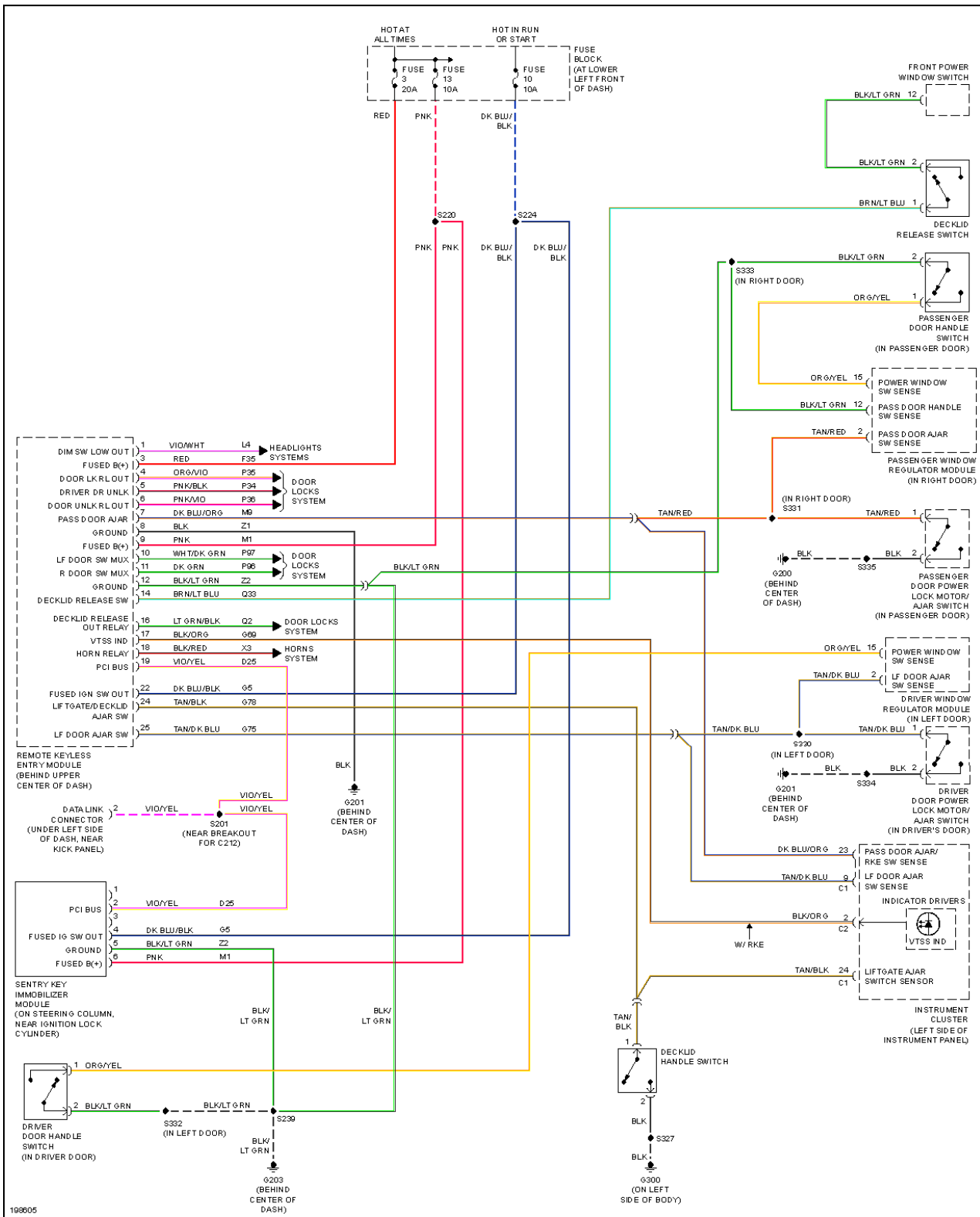

Fig. 4: Anti-theft Circuit, Convertible

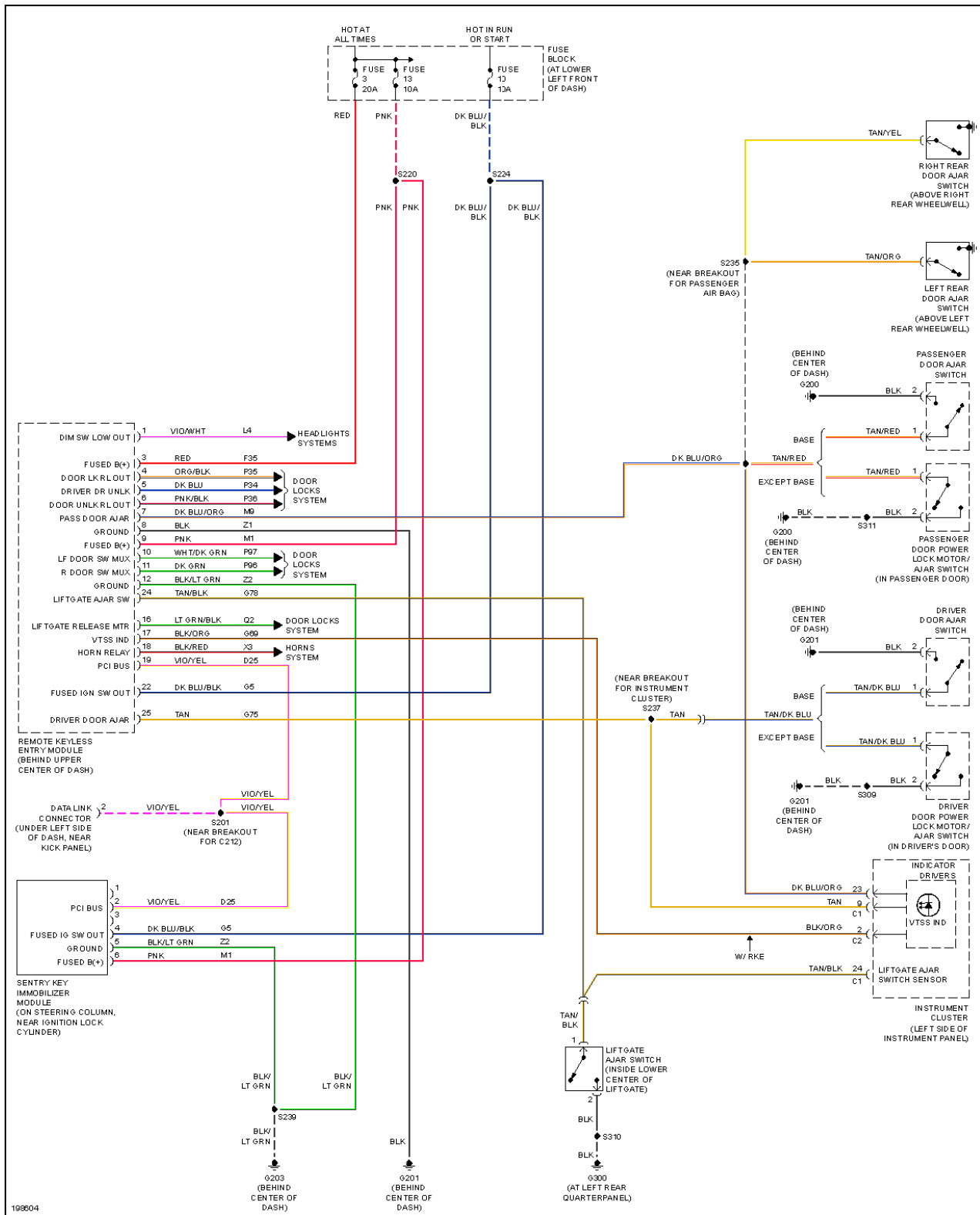

Fig. 5: Anti-theft Circuit, Except Convertible

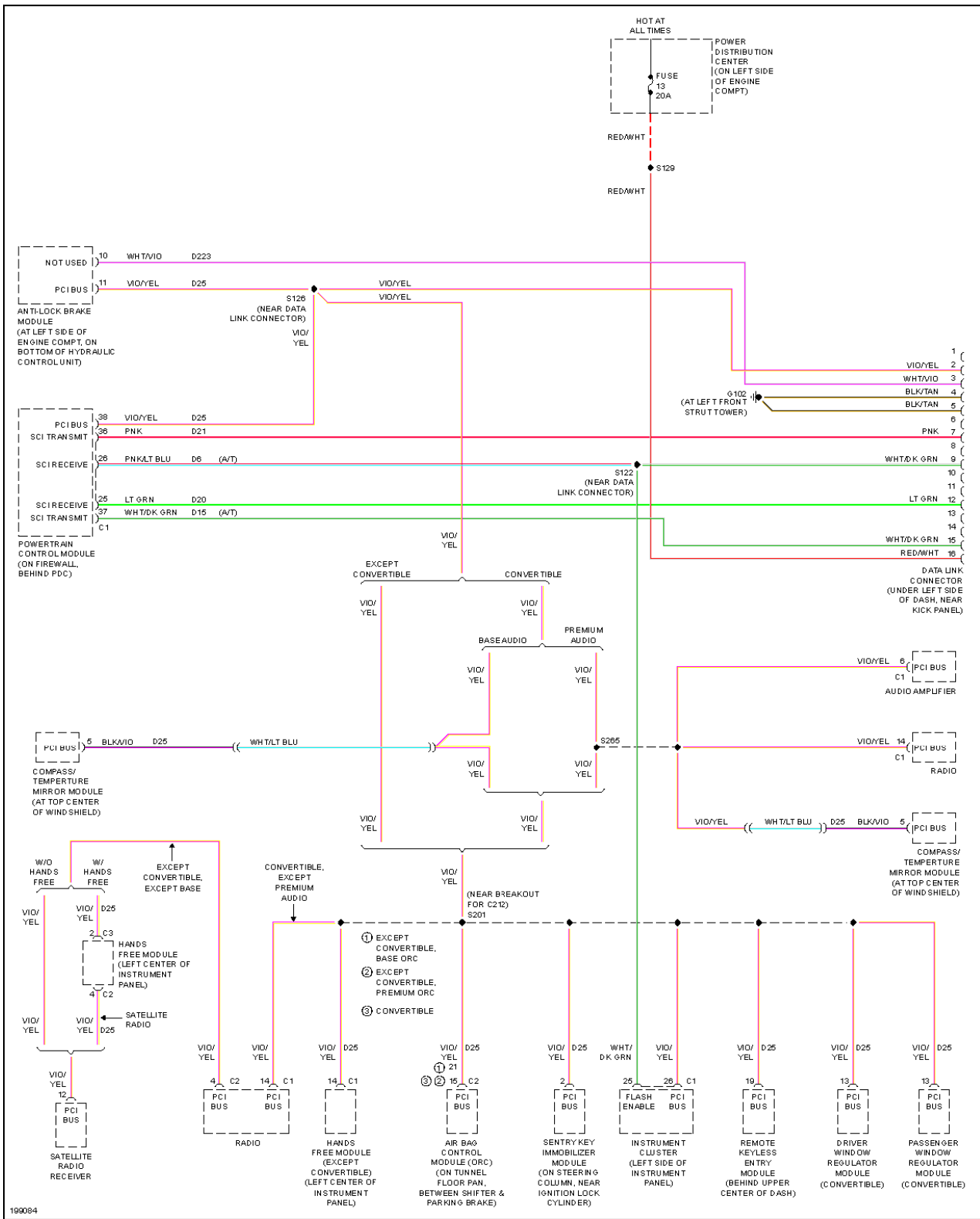

Fig. 6: Computer Data Lines Circuit

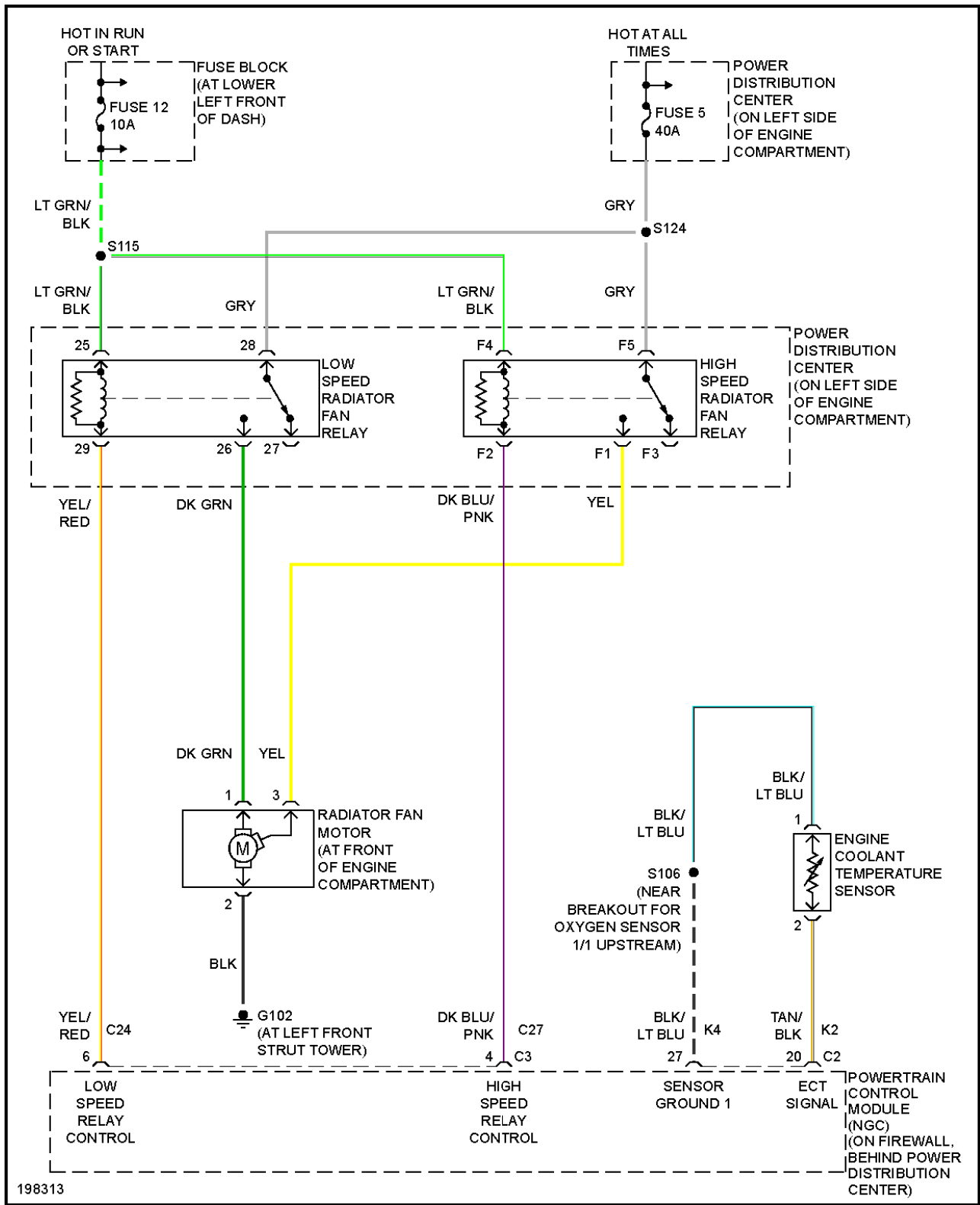

Fig. 7: 2.4L, Cooling Fan Circuit

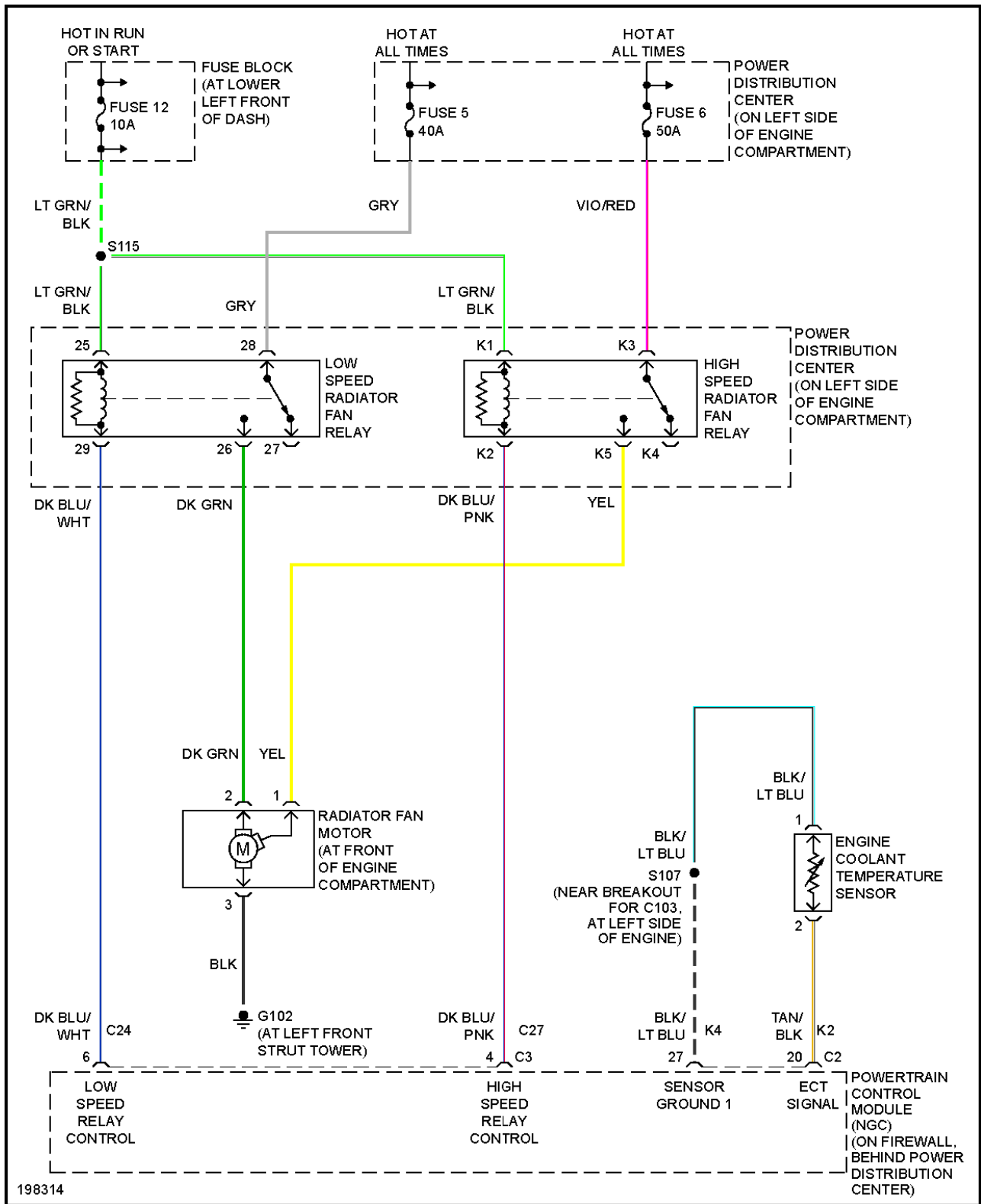

Fig. 8: 2.4L Turbo, Cooling Fan Circuit

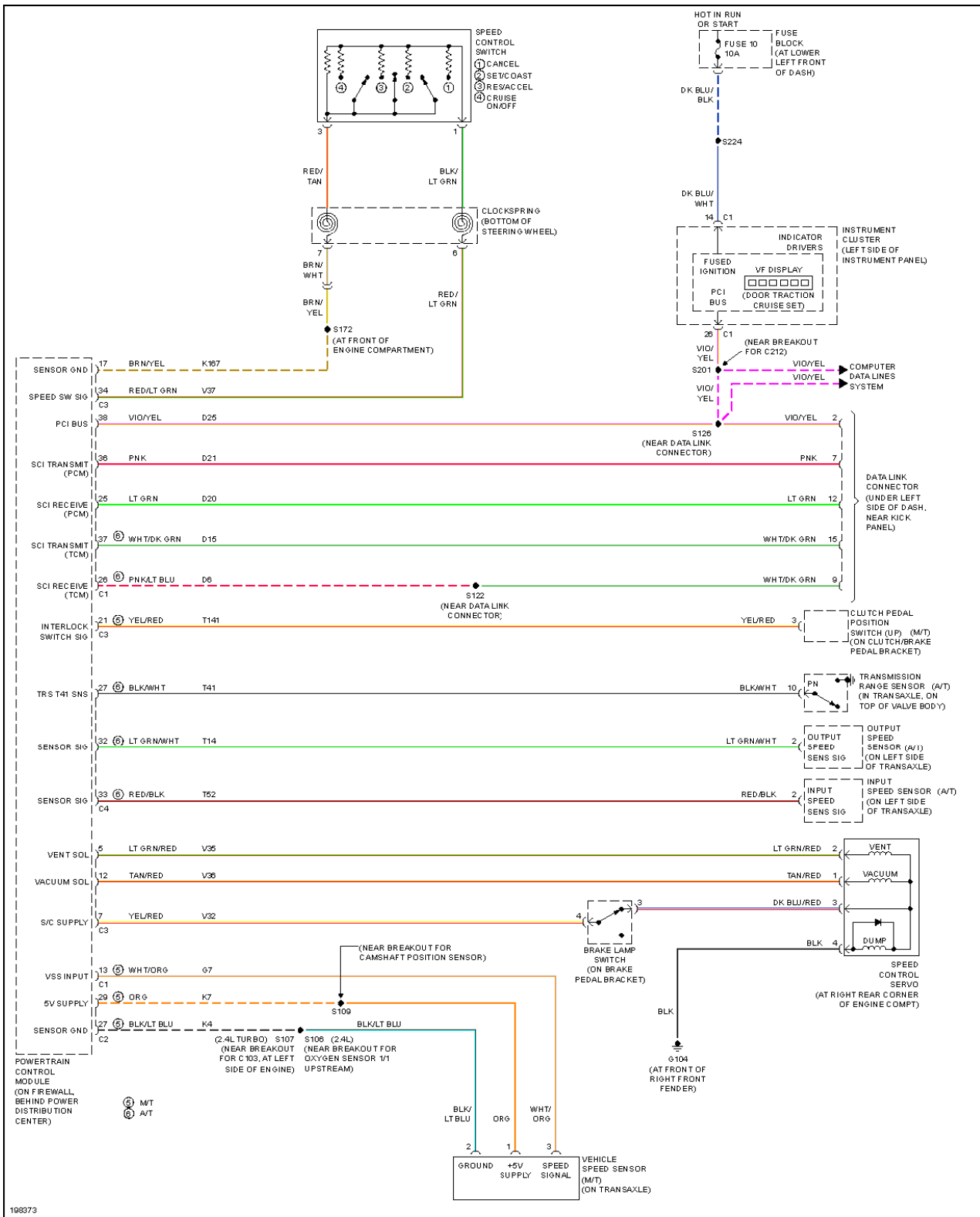

Fig. 9: Cruise Control Circuit

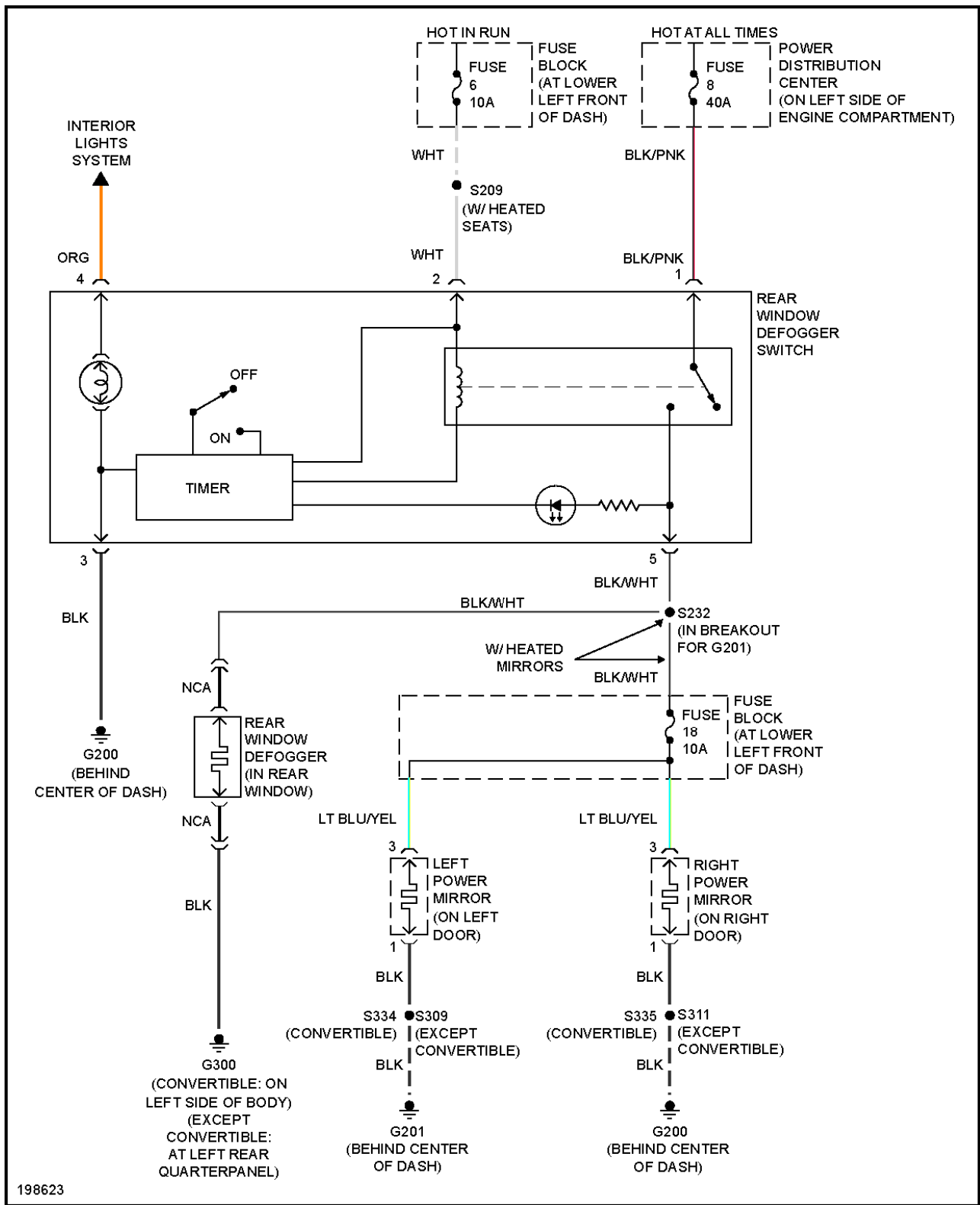

Fig. 10: Defoggers Circuit

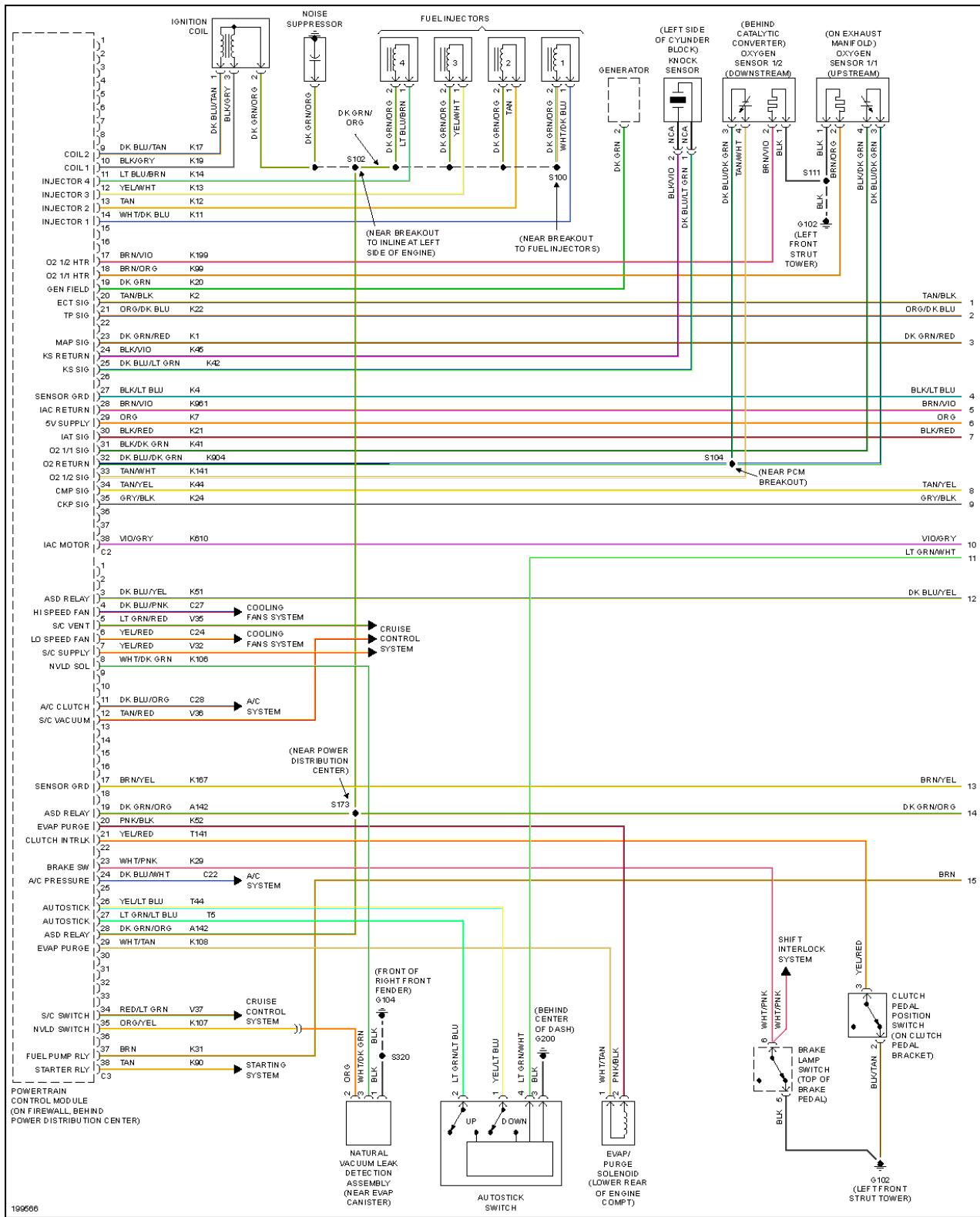

Fig. 11: 2.4L, Engine Performance Circuit (1 of 3)

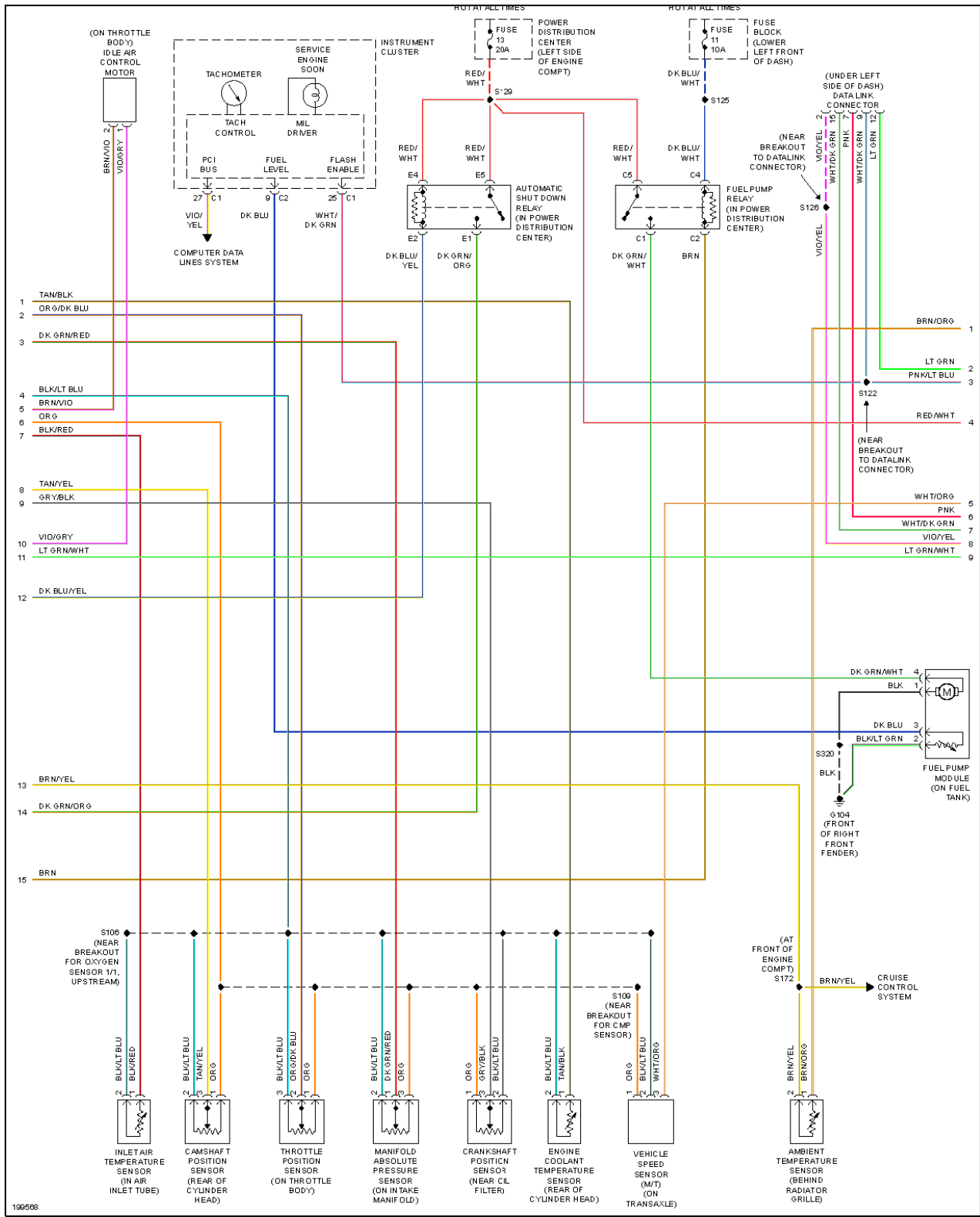

Fig. 12: 2.4L, Engine Performance Circuit (2 of 3)

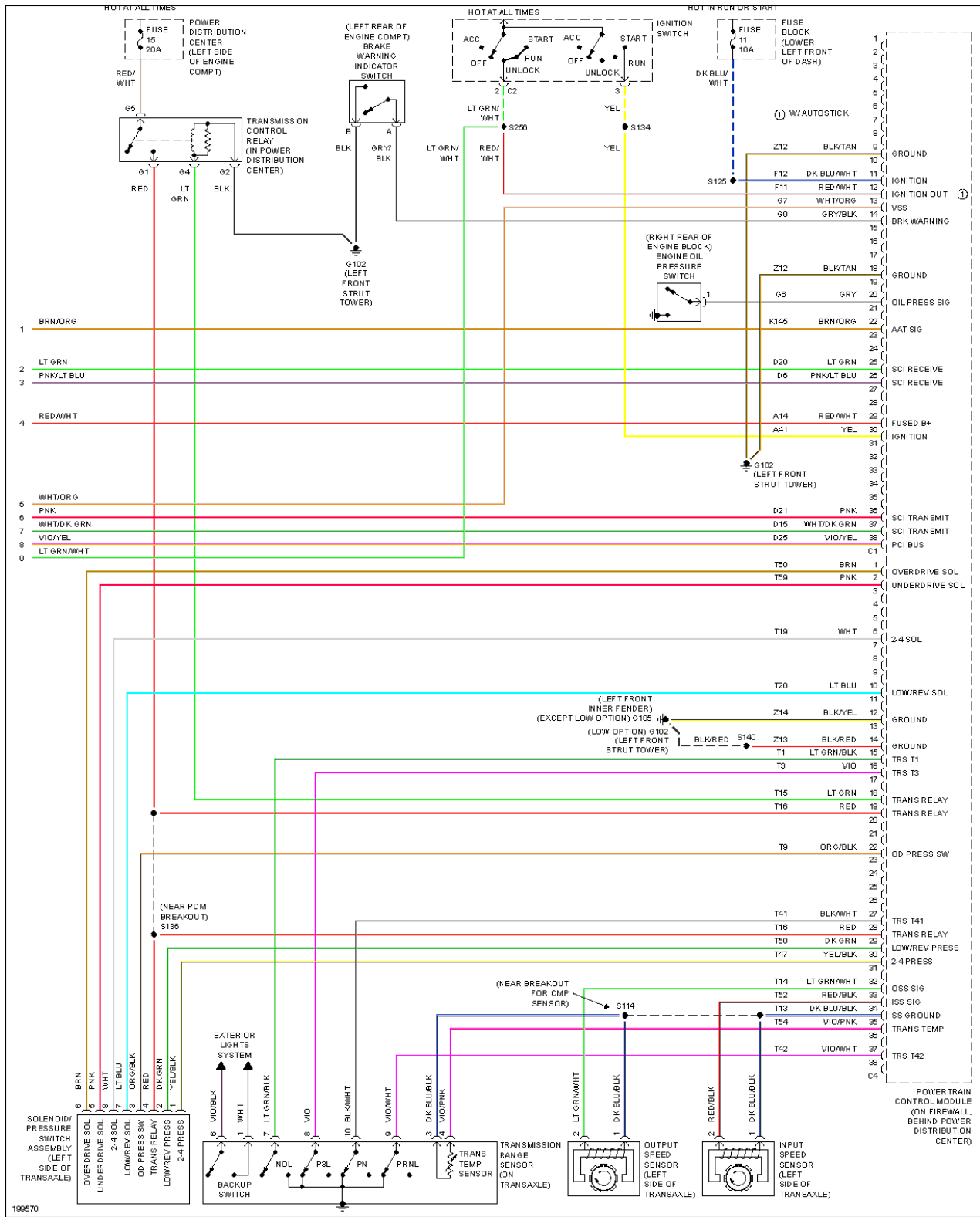

Fig. 13: 2.4L, Engine Performance Circuit (3 of 3)

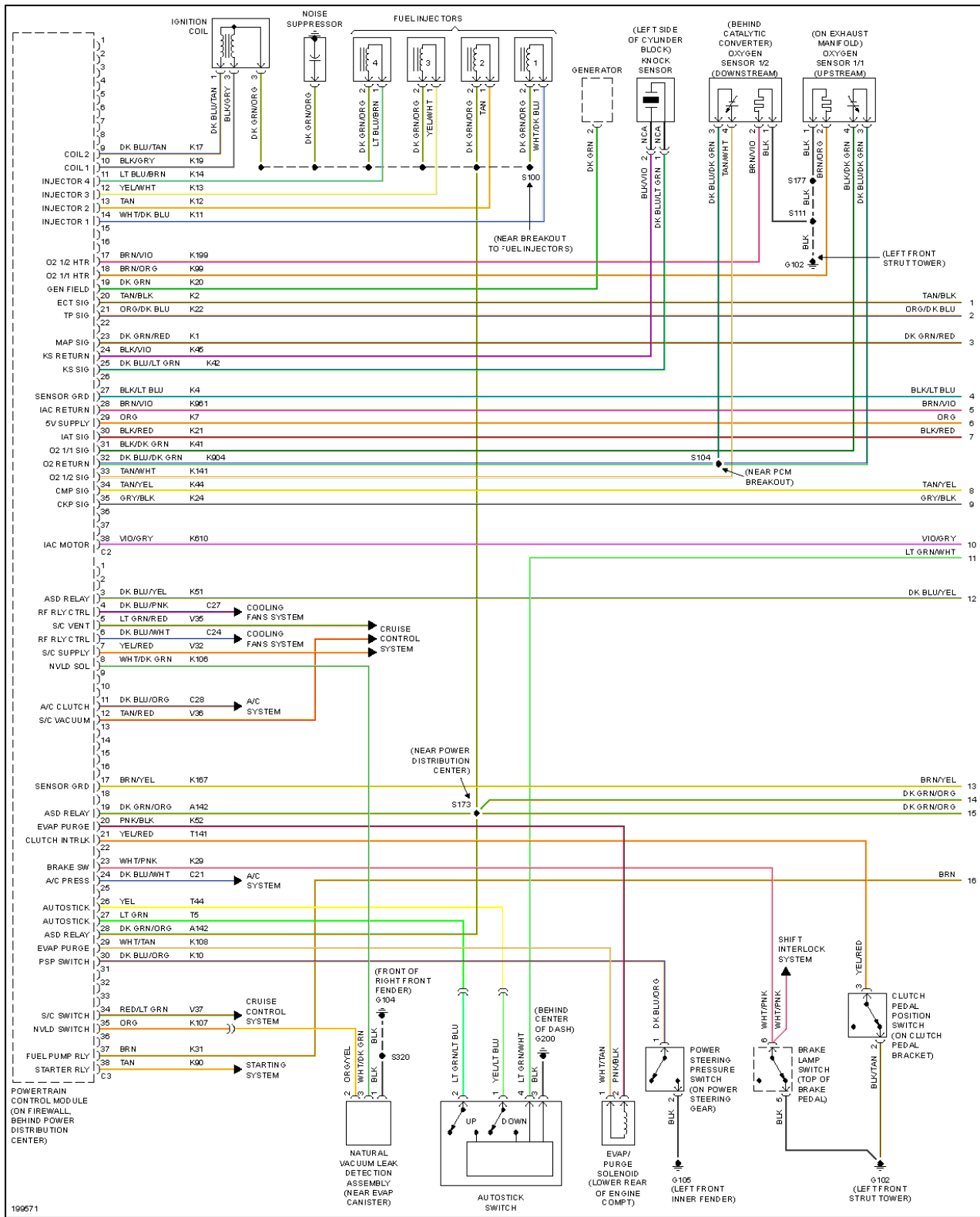

Fig. 14: 2.4L Turbo, Engine Performance Circuit (1 of 3)

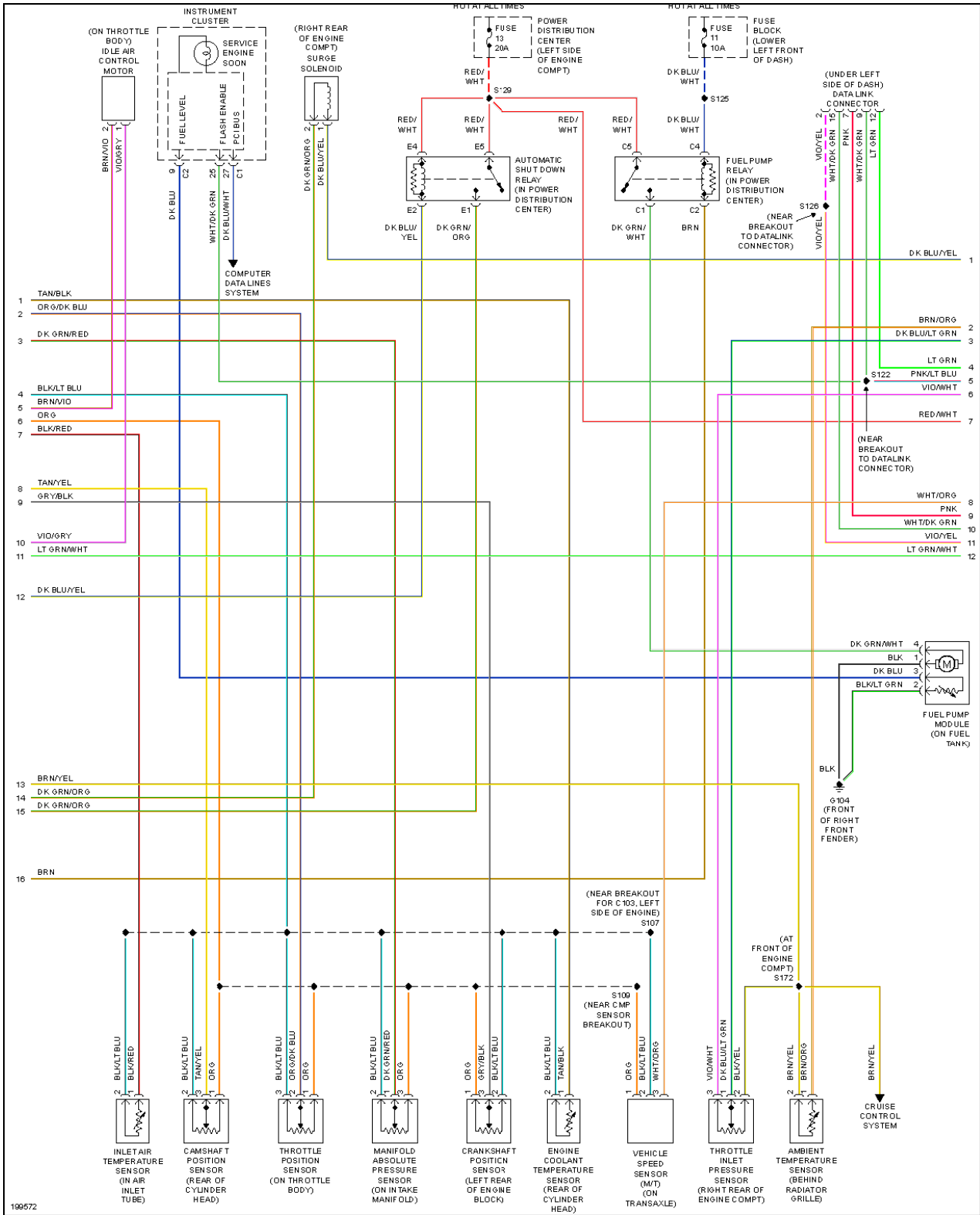

Fig. 15: 2.4L Turbo, Engine Performance Circuit (2 of 3)

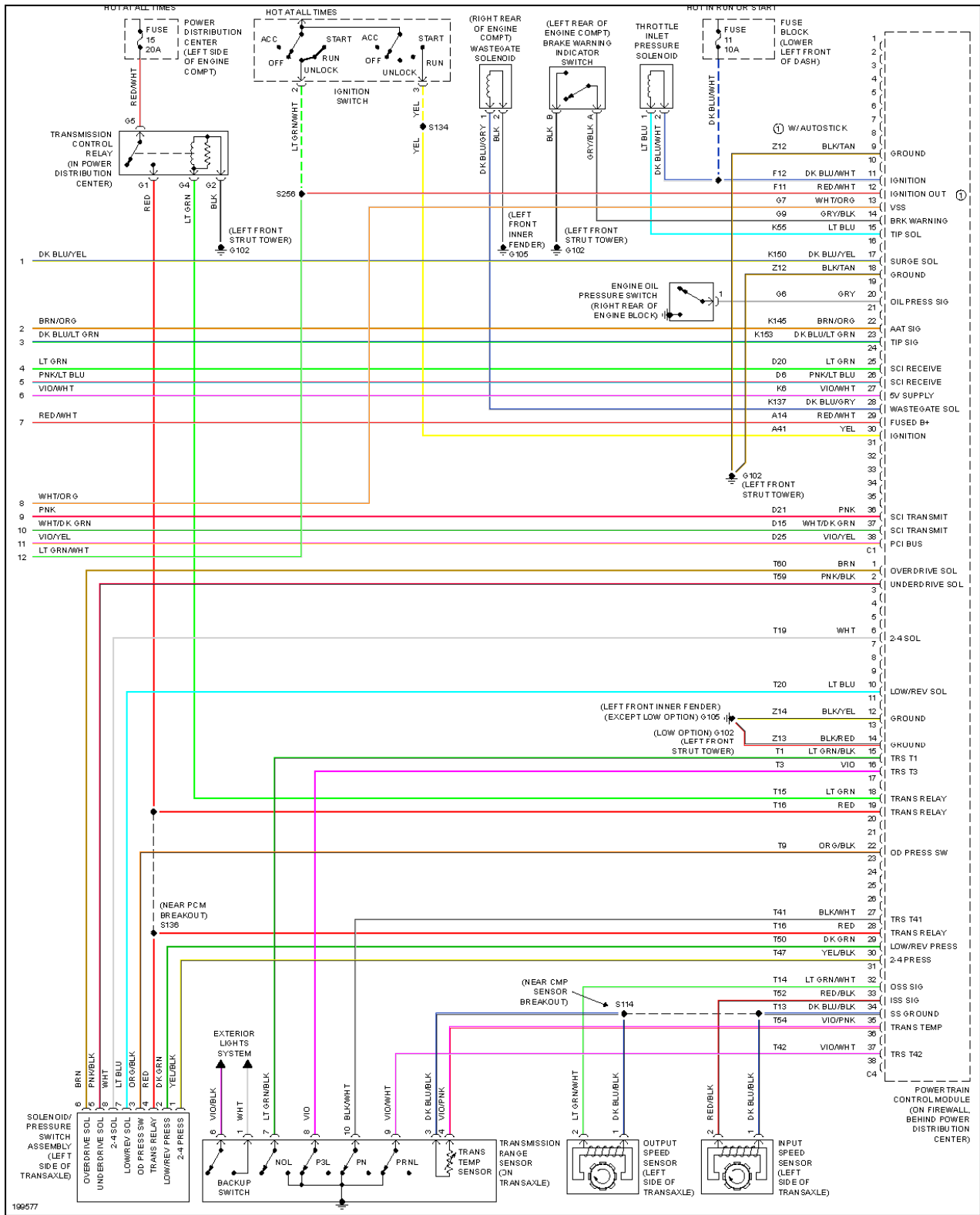

Fig. 16: 2.4L Turbo, Engine Performance Circuit (3 of 3)

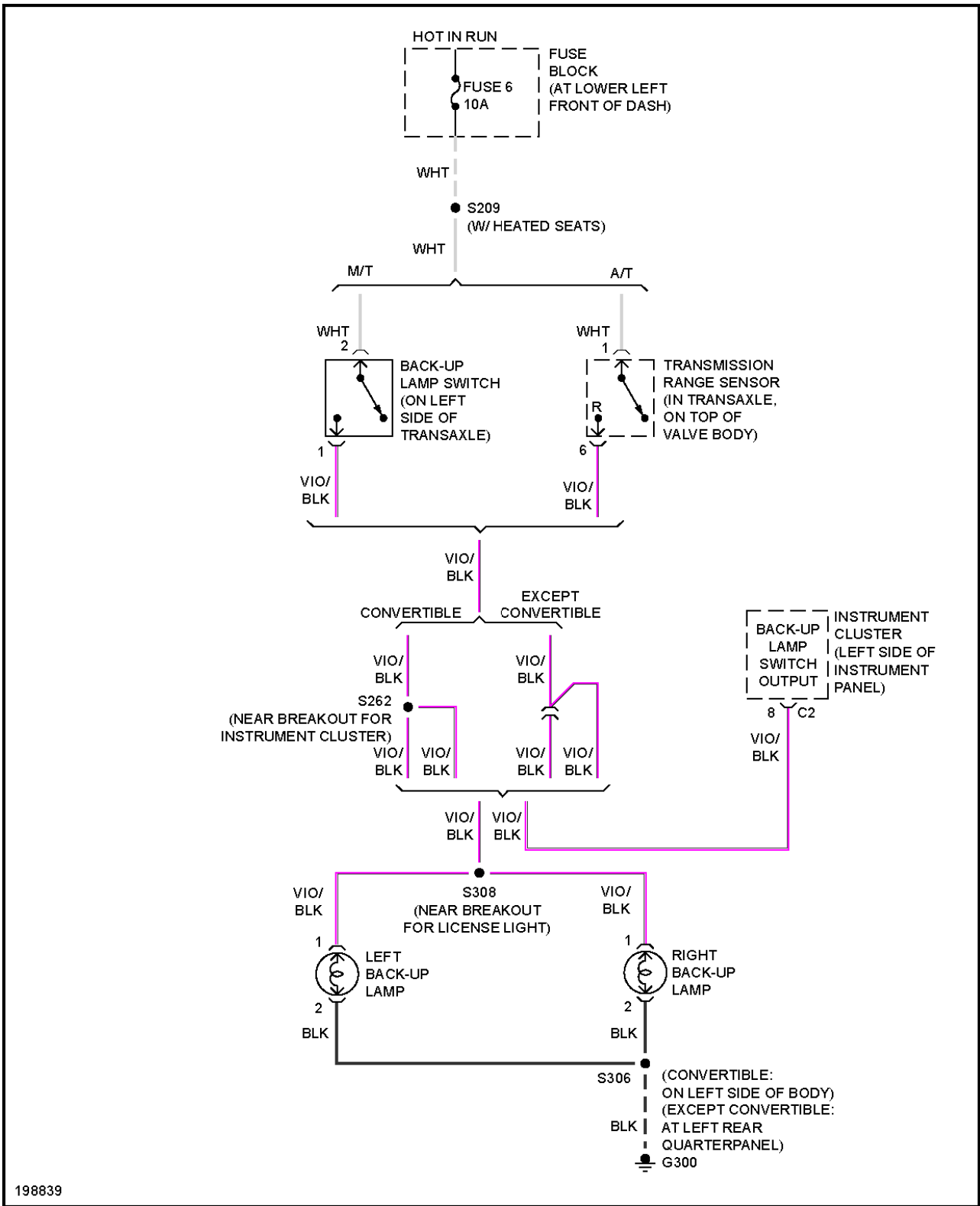

Fig. 17: Back-up Lamps Circuit

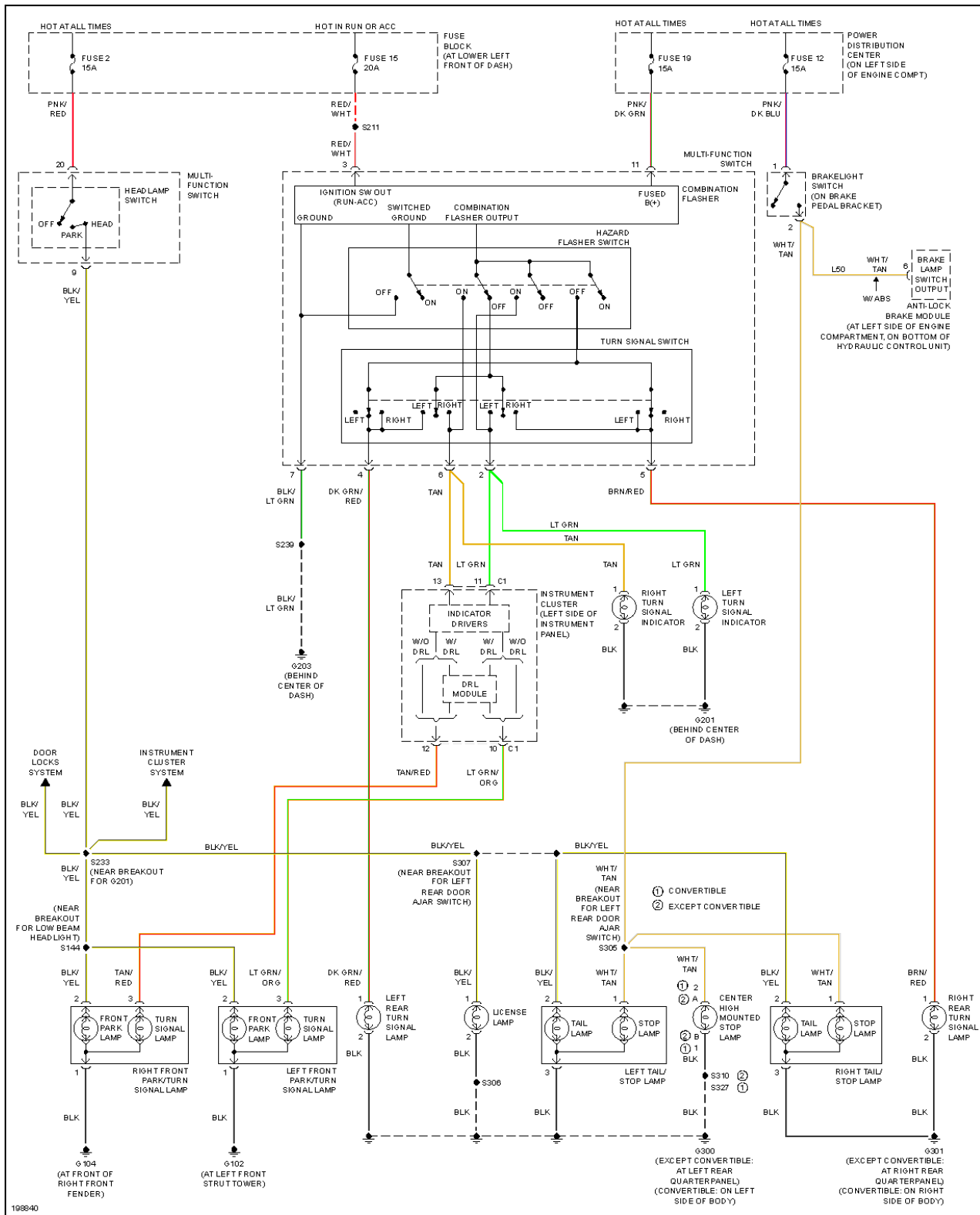

Fig. 18: Exterior Lamps Circuit

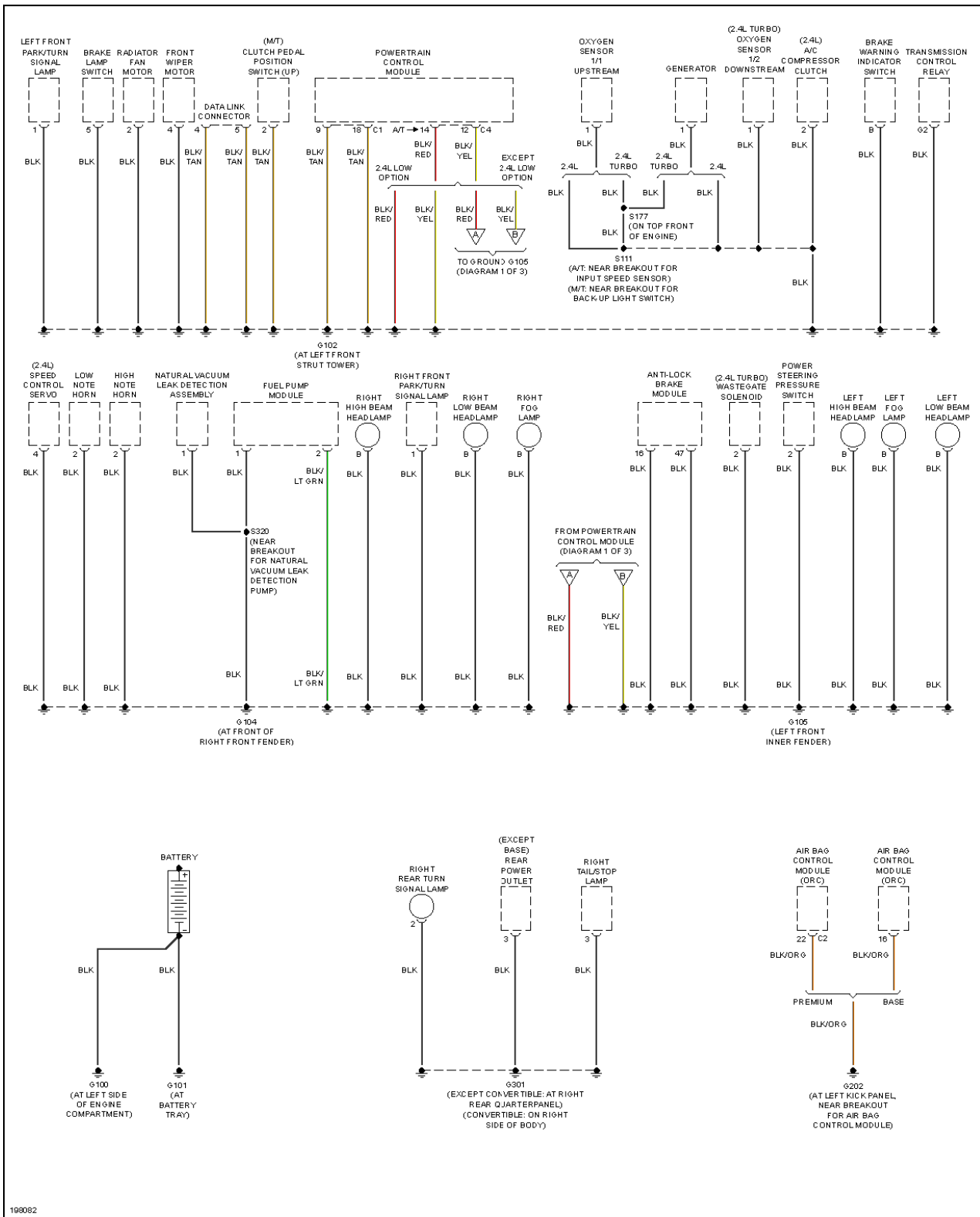

Fig. 19: Ground Distribution Circuit (1 of 3)

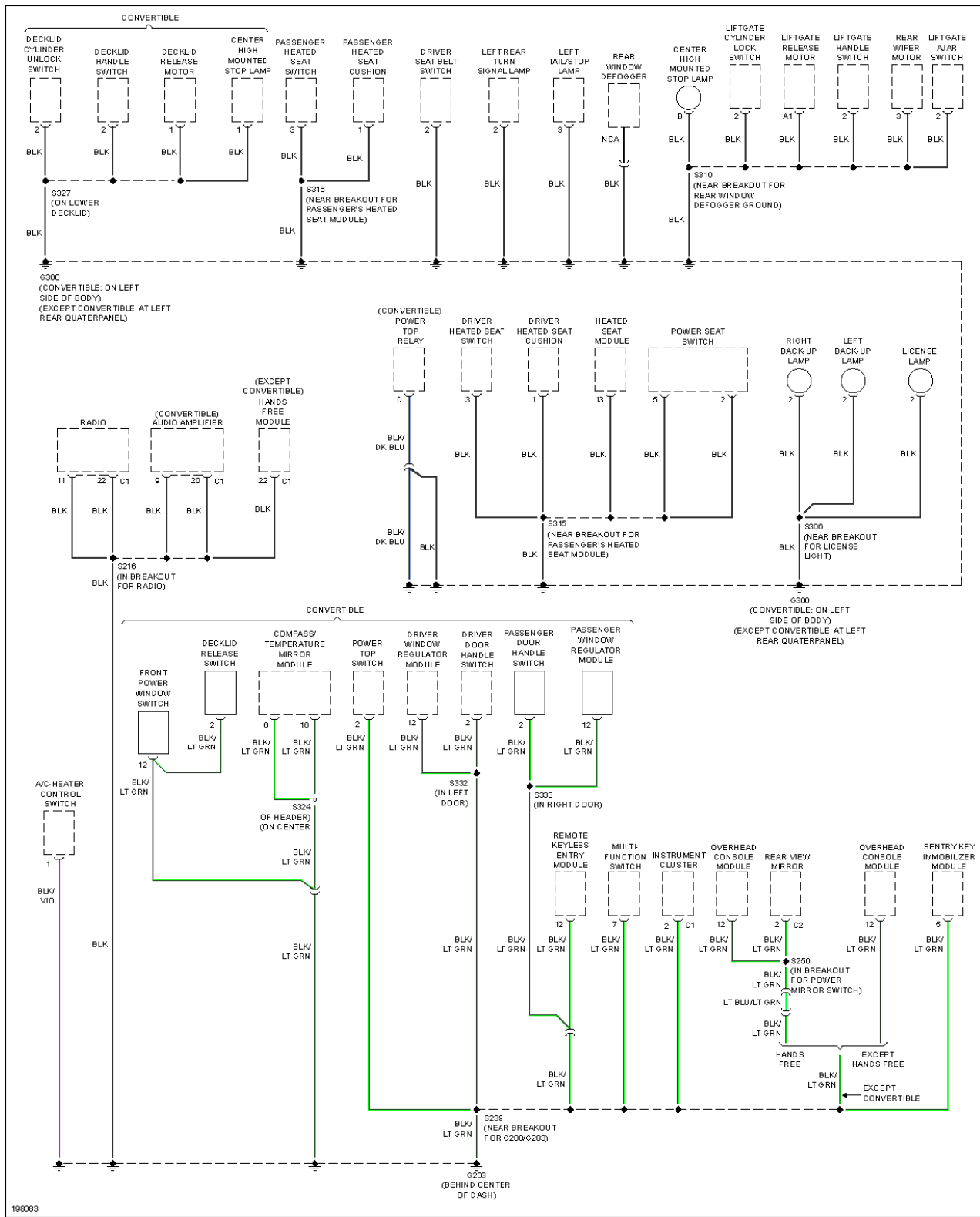

Fig. 20: Ground Distribution Circuit (2 of 3)

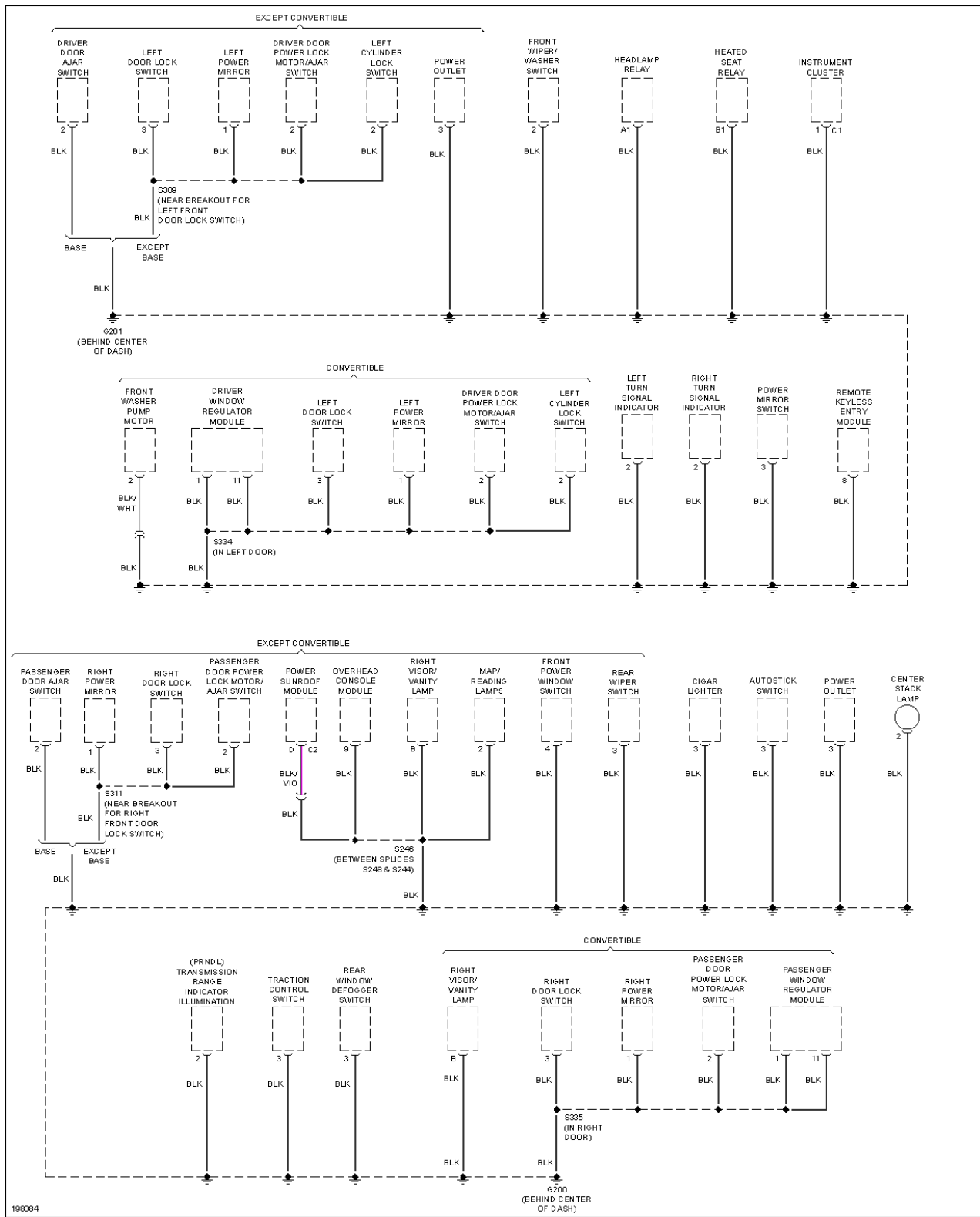
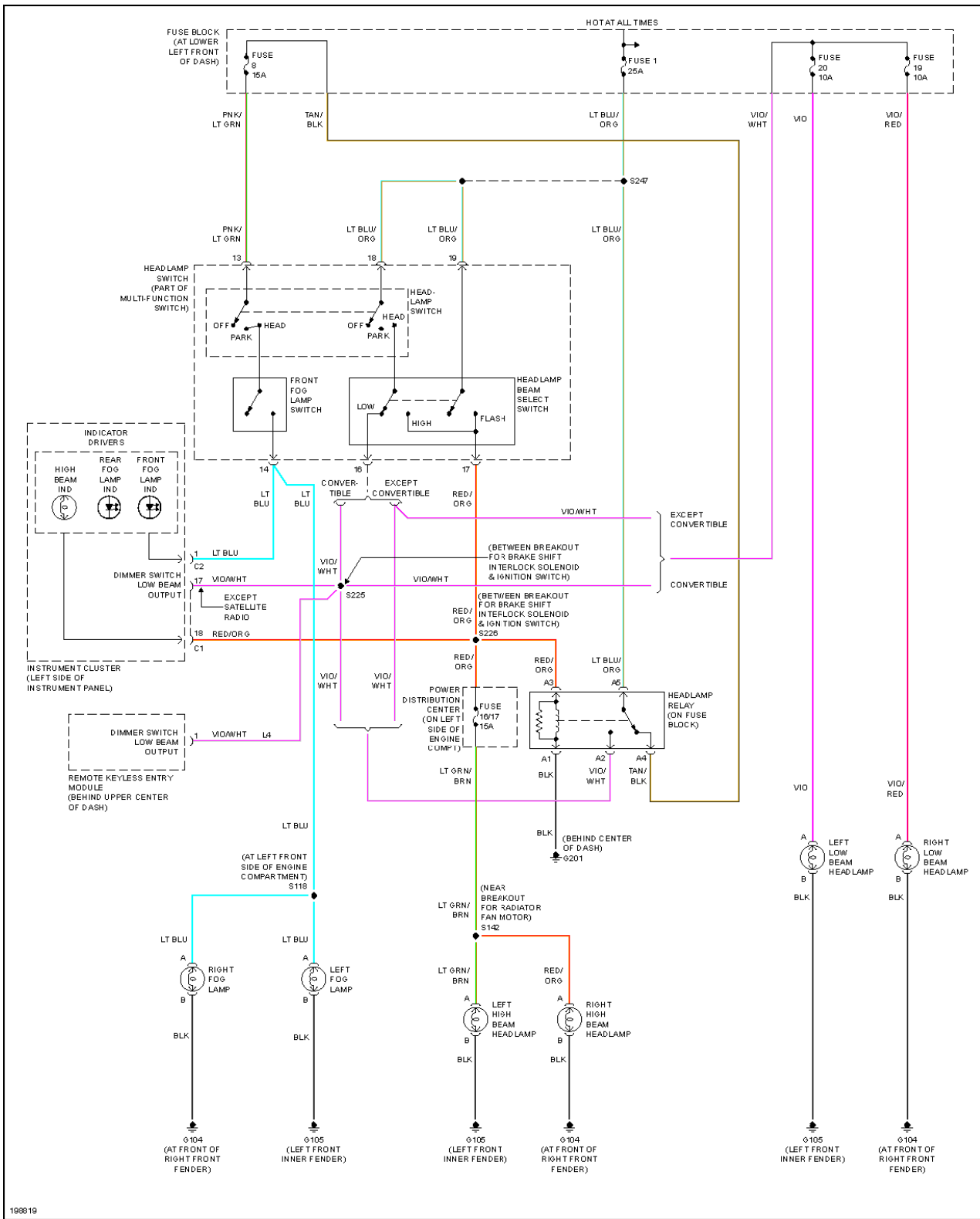

Fig. 21: Ground Distribution Circuit (3 of 3)



198819

Fig. 22: Headlights Circuit

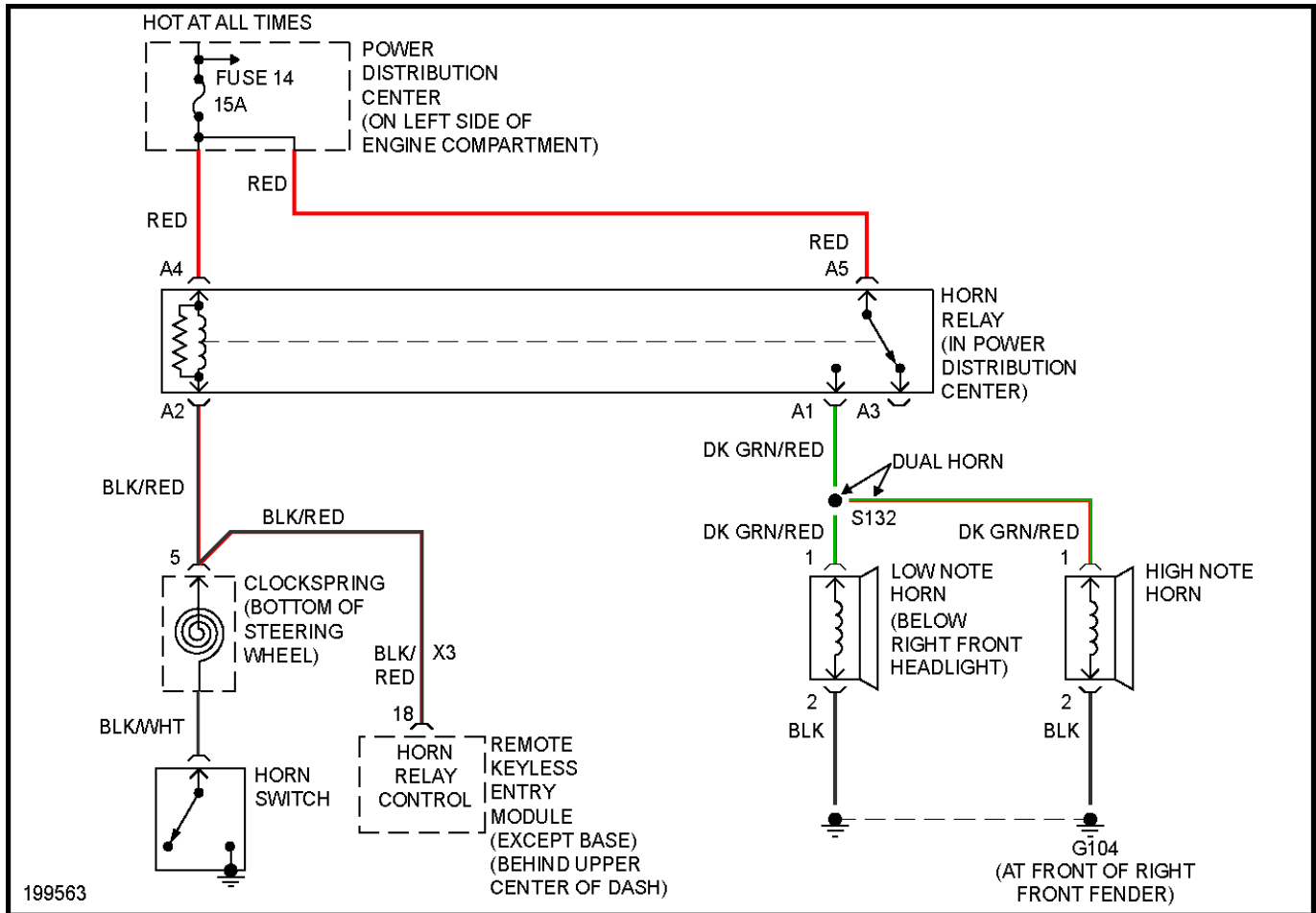

Fig. 23: Horn Circuit

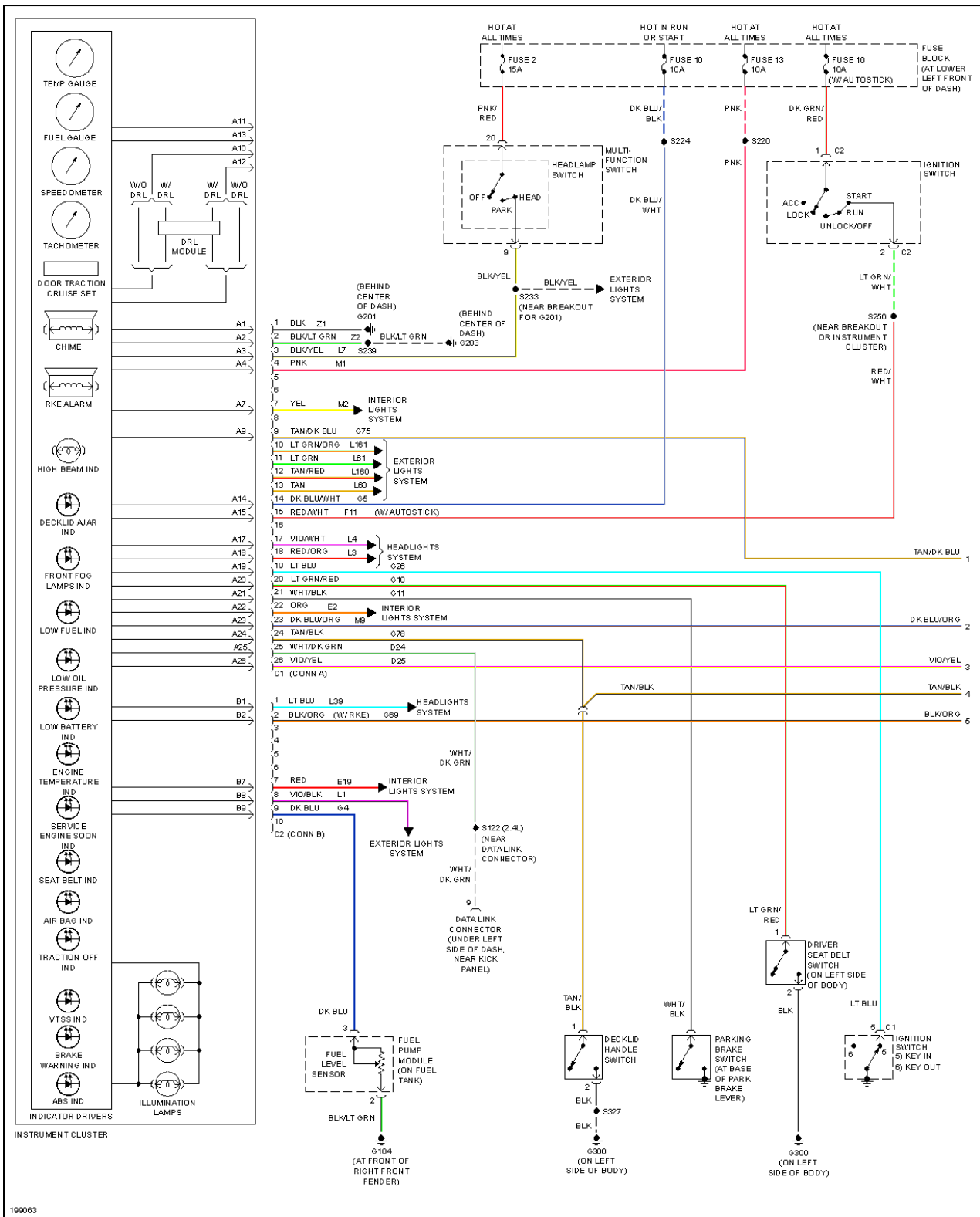

Fig. 24: Instrument Cluster Circuit, Convertible (1 of 2)

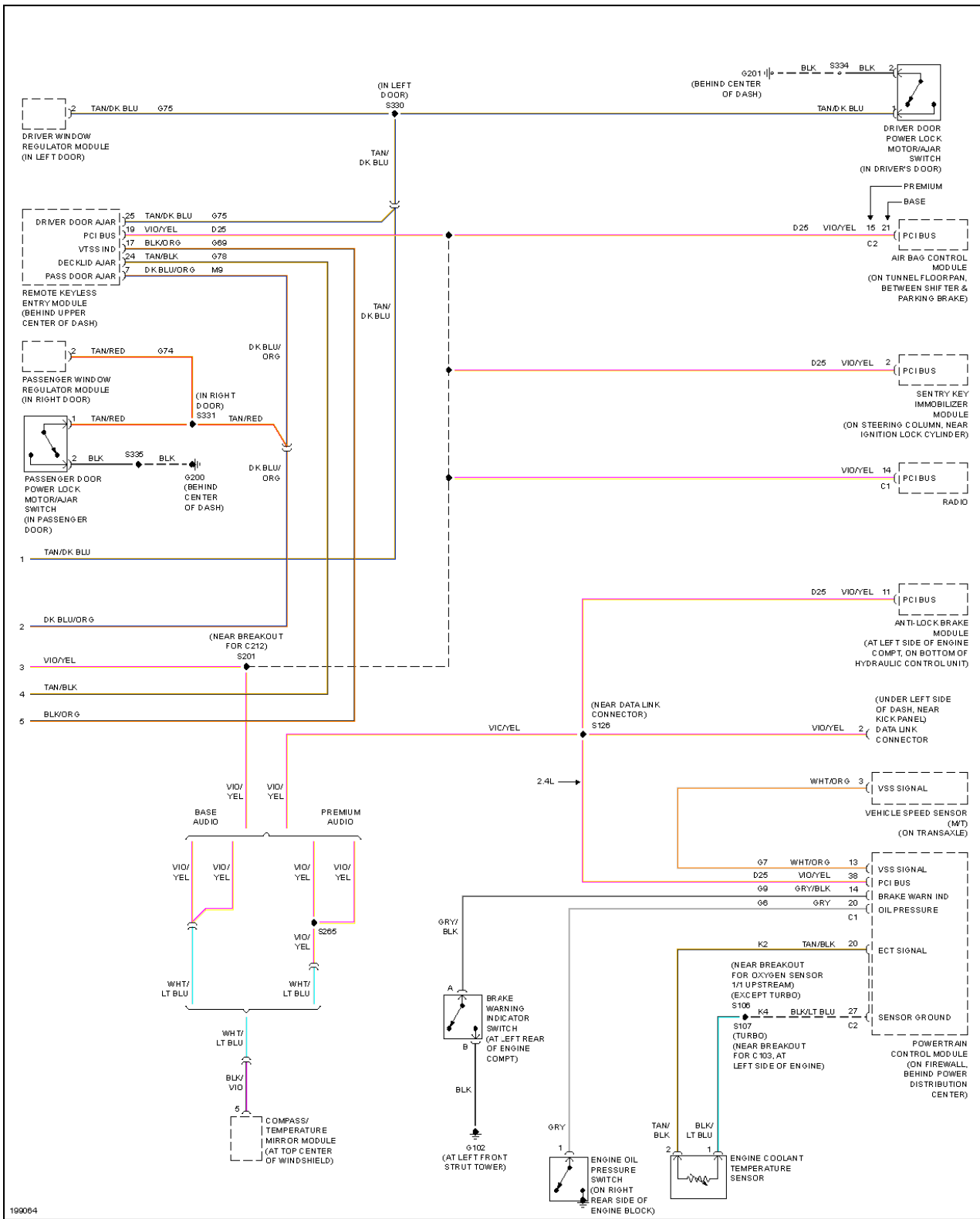

Fig. 25: Instrument Cluster Circuit, Convertible (2 of 2)

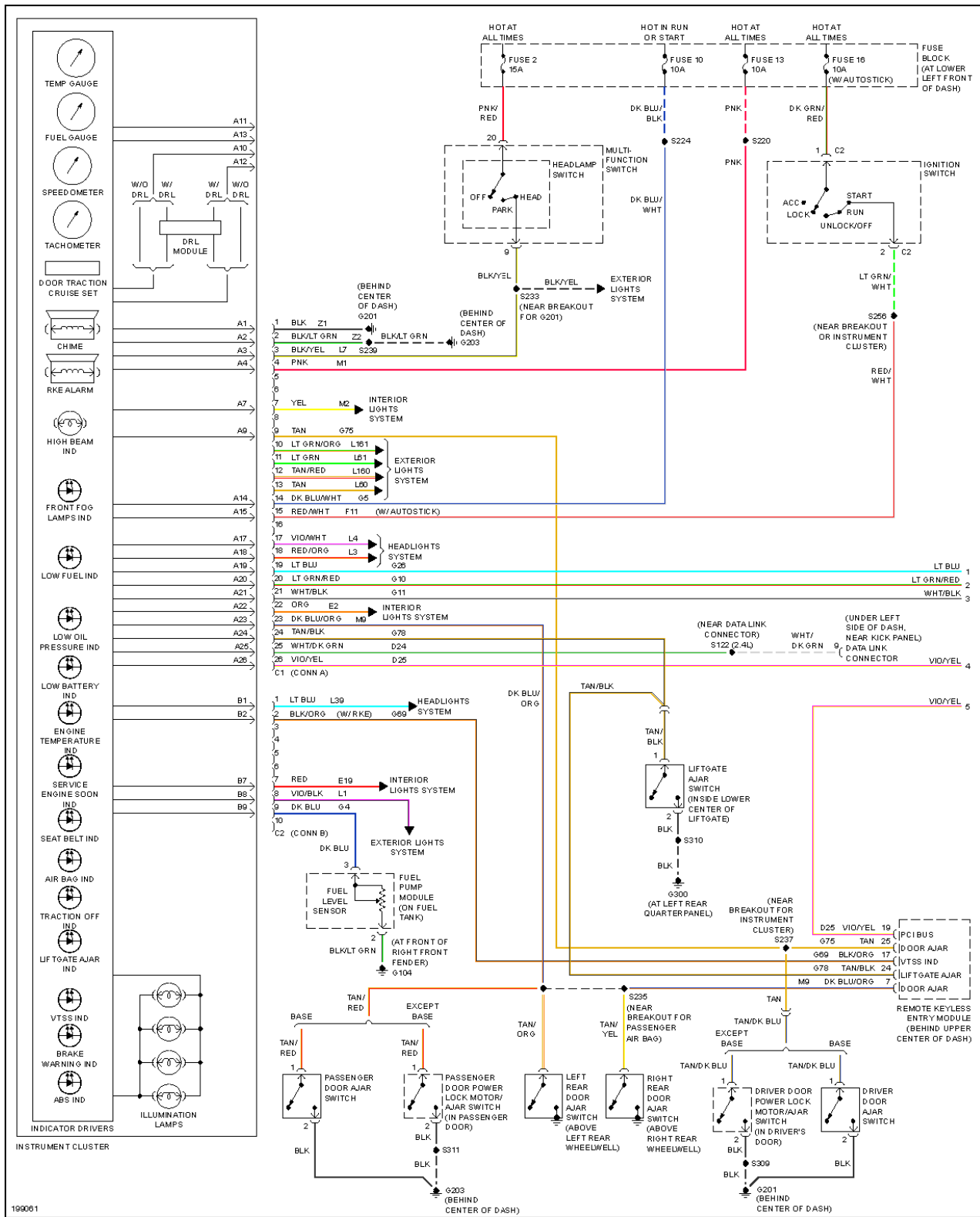

Fig. 26: Instrument Cluster Circuit, Except Convertible (1 of 2)

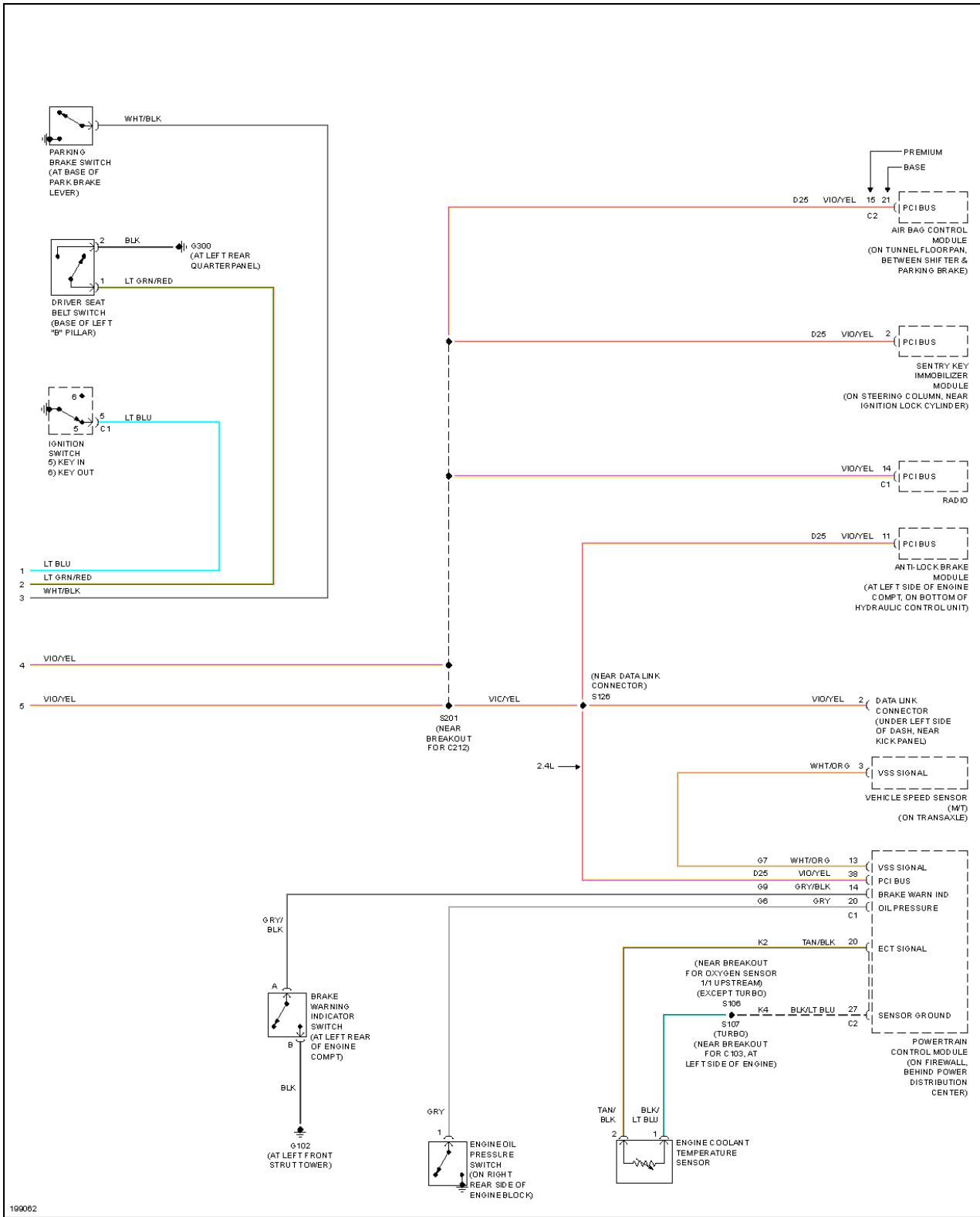

Fig. 27: Instrument Cluster Circuit, Except Convertible (2 of 2)

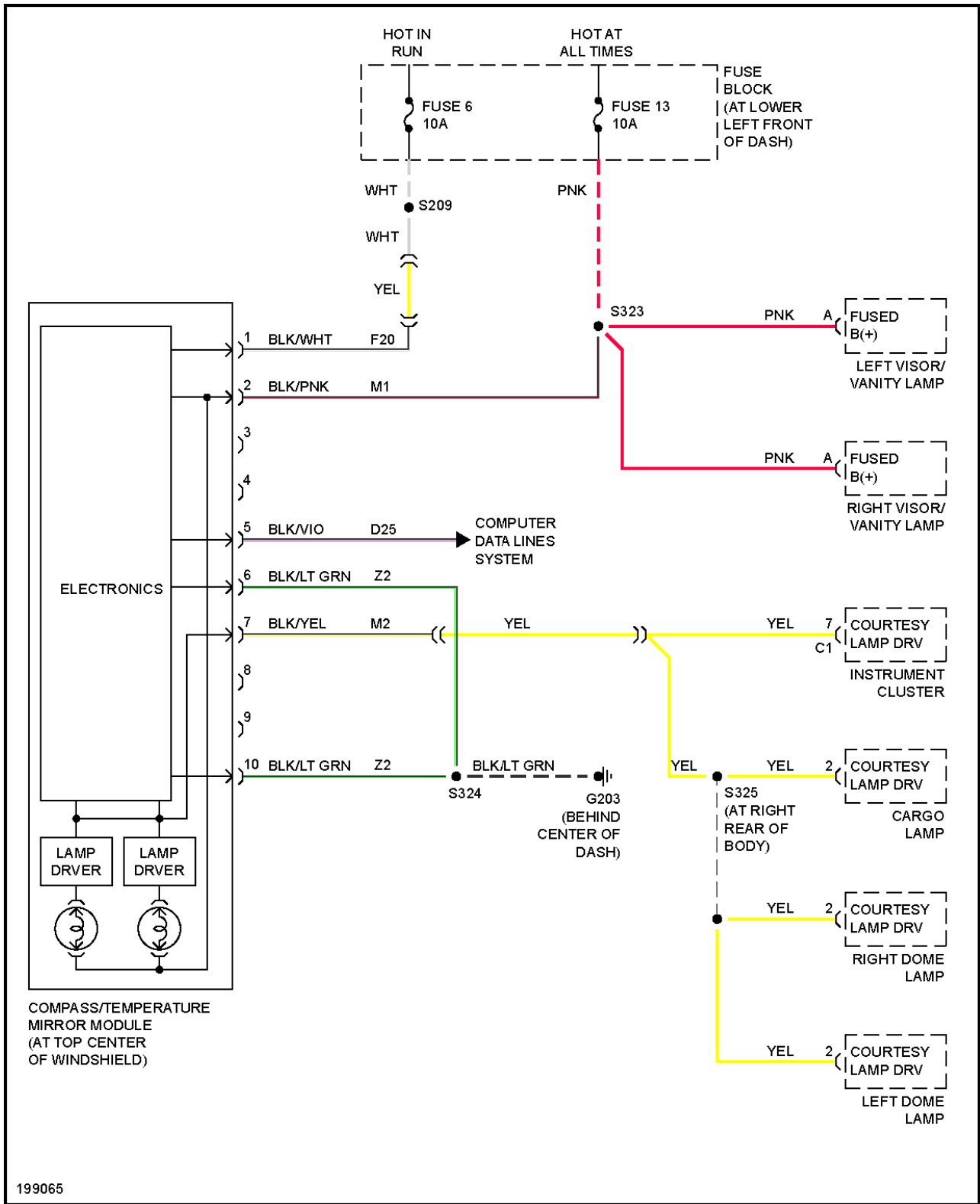

Fig. 28: Overhead Console Circuit, Convertible

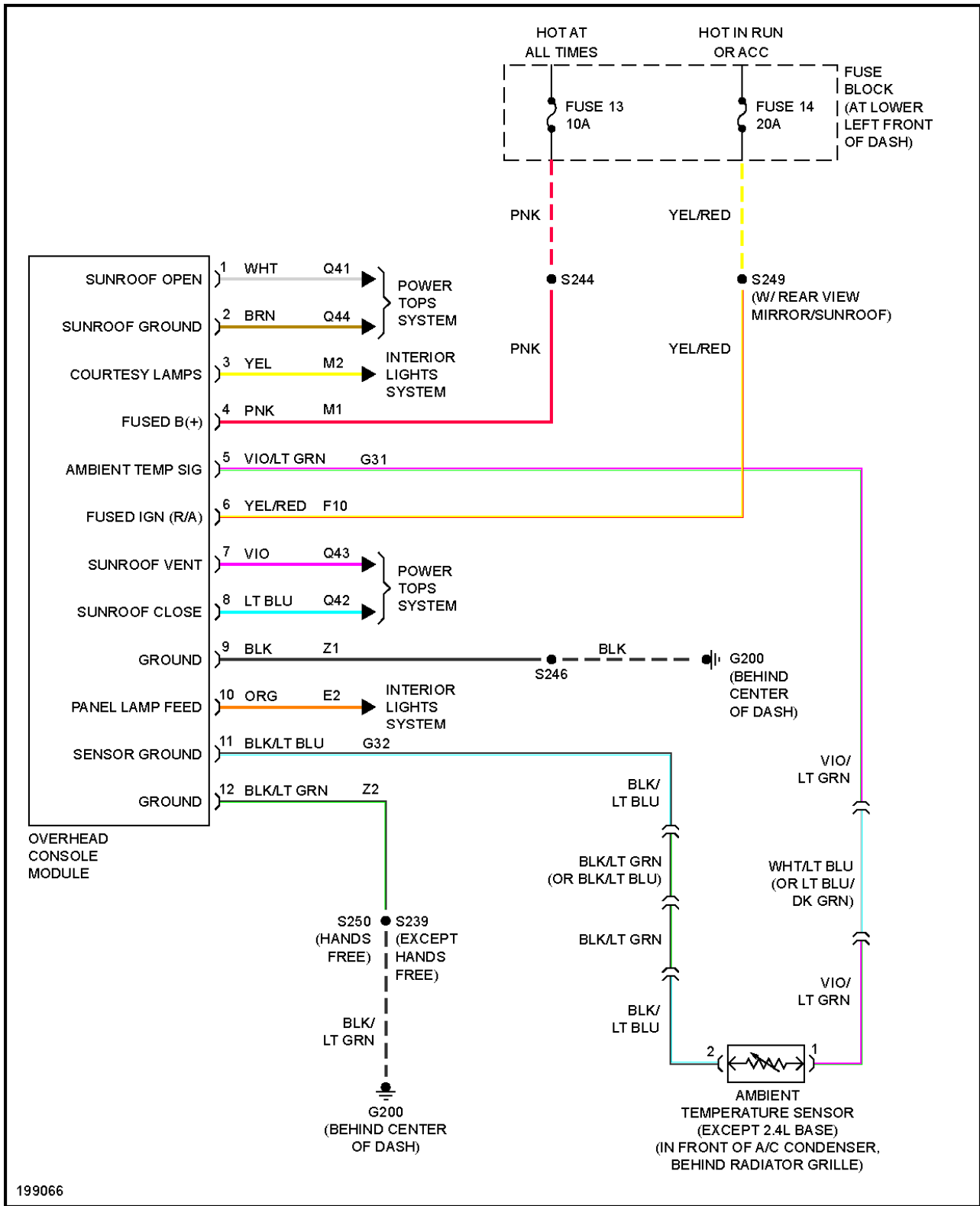

Fig. 29: Overhead Console Circuit, Except Convertible

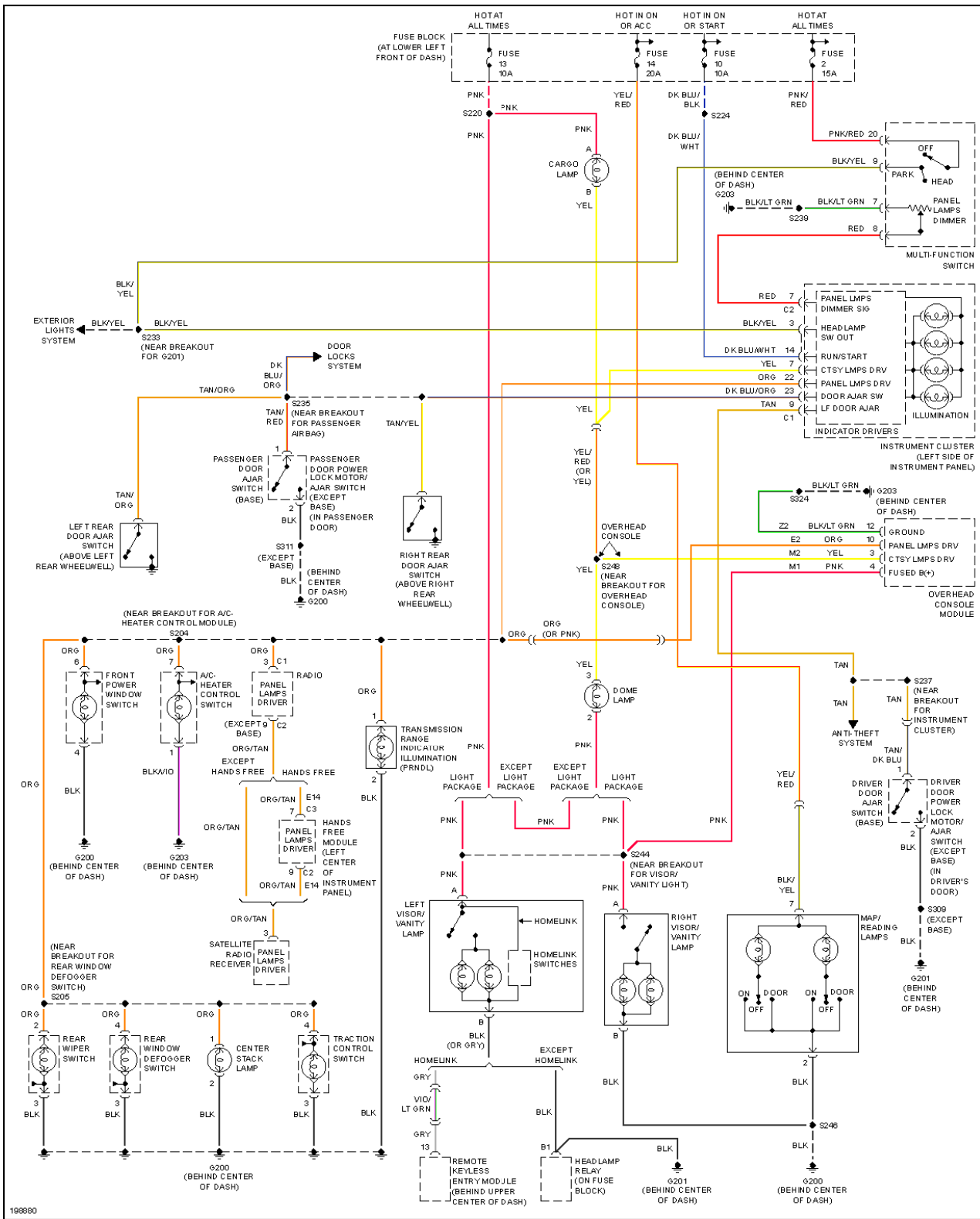

Fig. 31: Interior Lights Circuit, Except Convertible

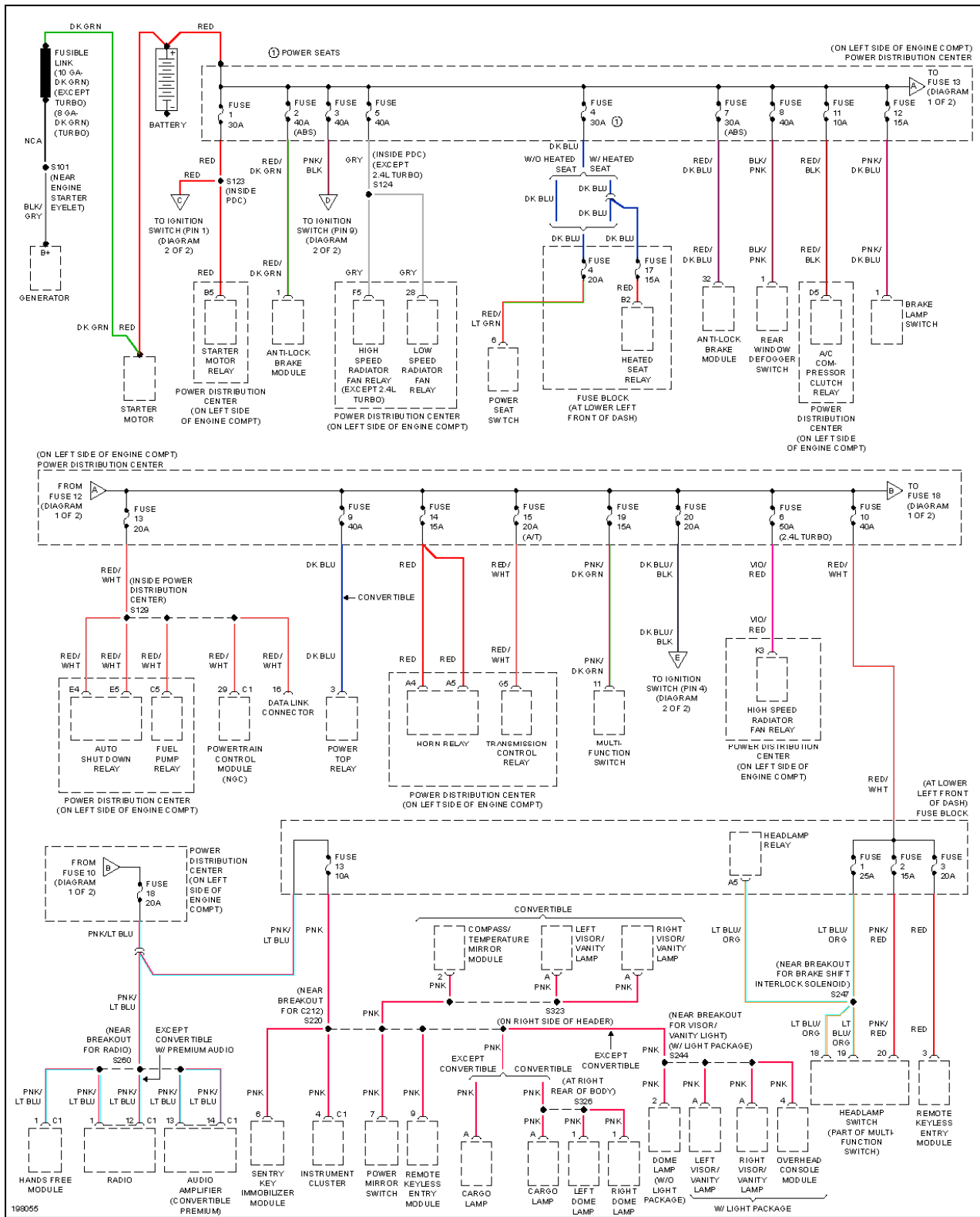

Fig. 32: Power Distribution Circuit (1 of 2)

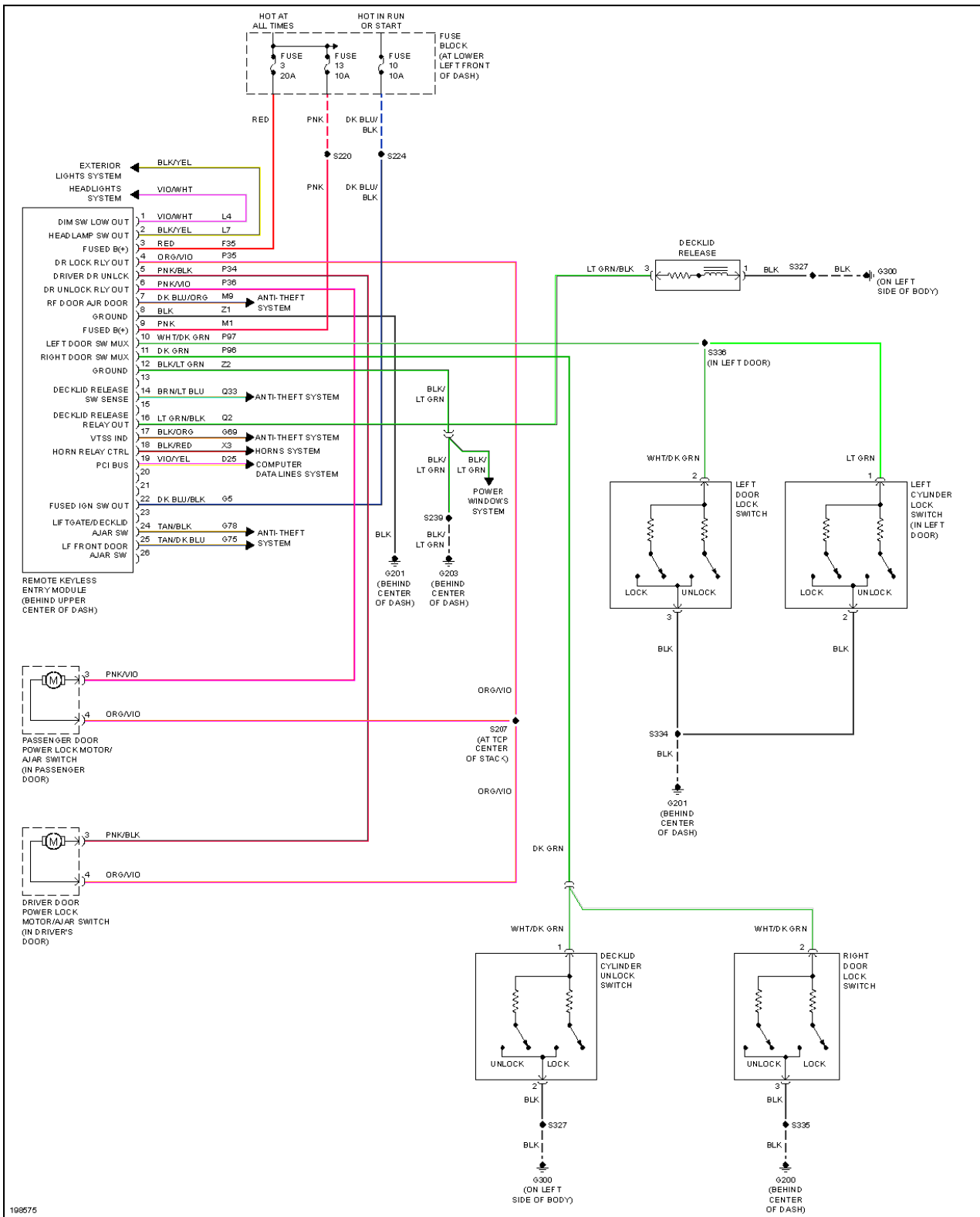

Fig. 34: Power Door Locks Circuit, Convertible

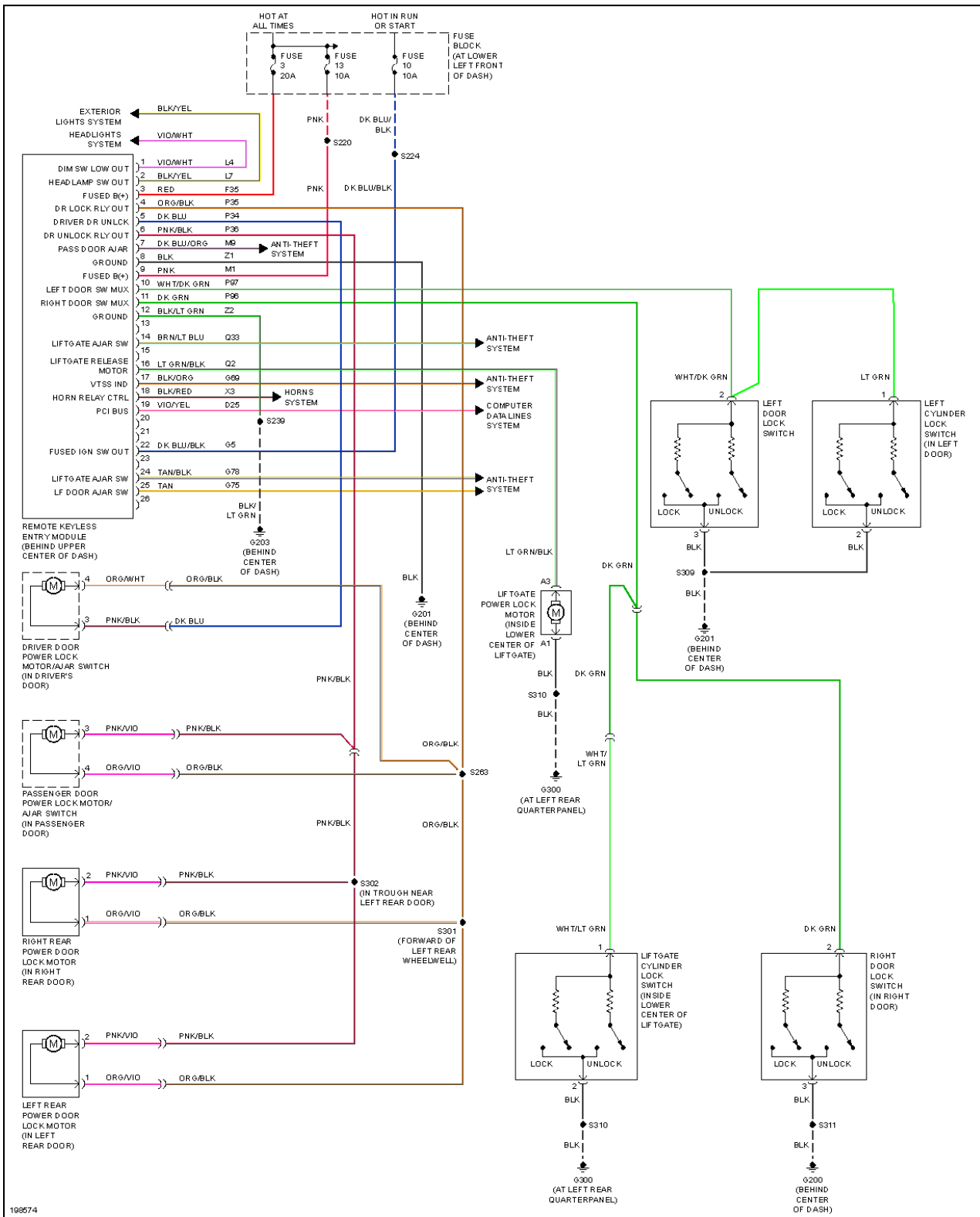

Fig. 35: Power Door Locks Circuit, Except Convertible

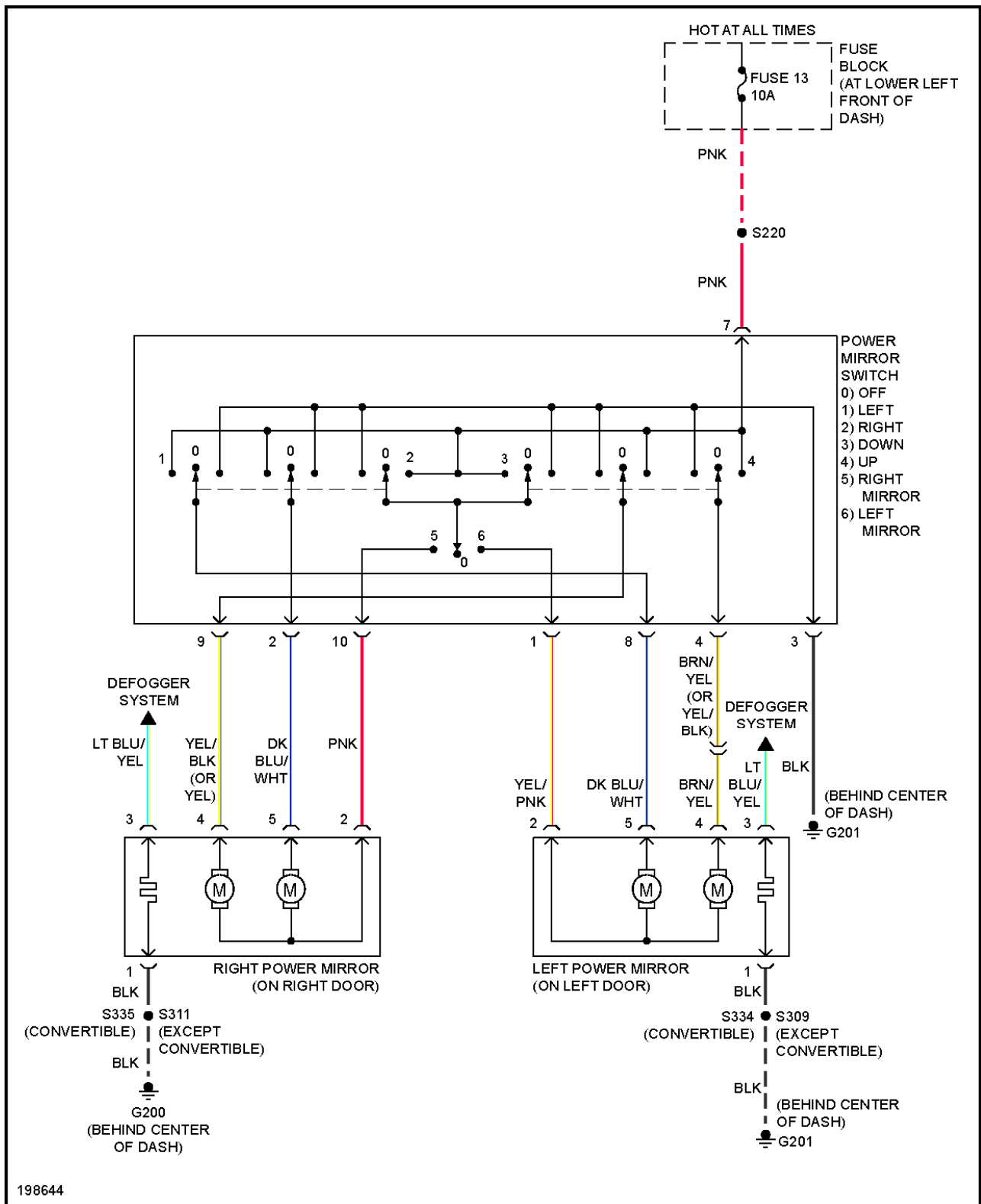

Fig. 36: Power Mirrors Circuit

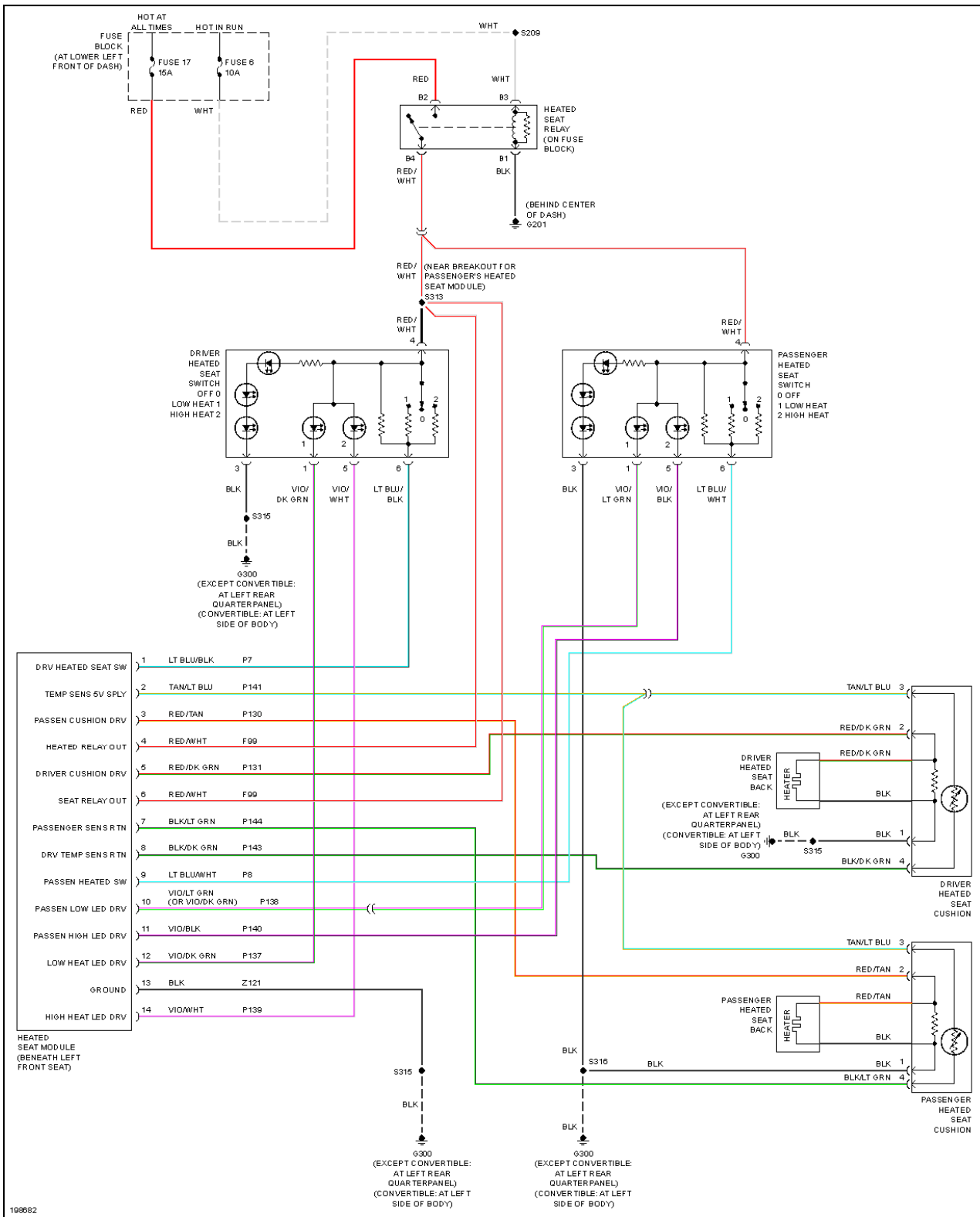

Fig. 37: Heated Seats Circuit

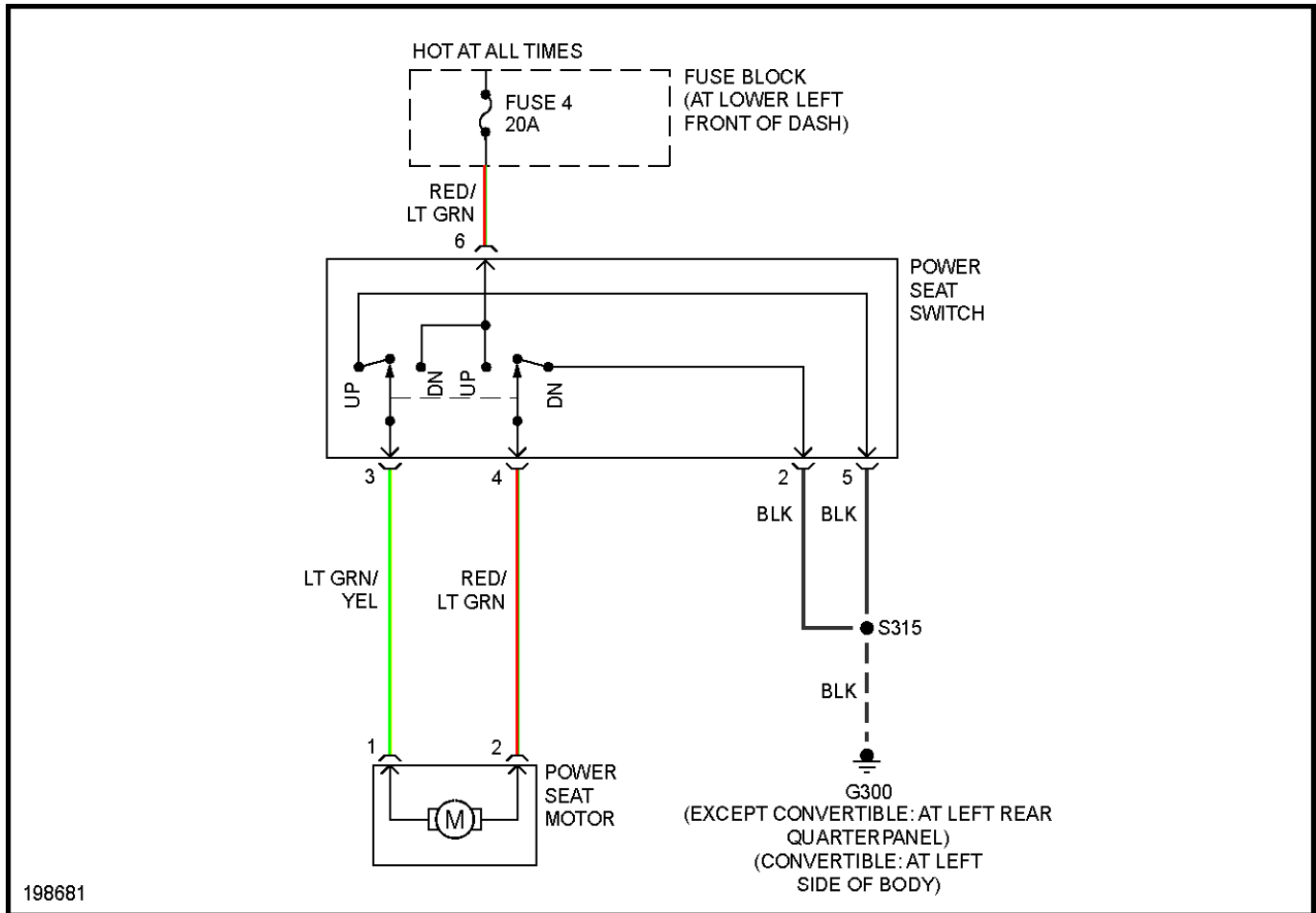

Fig. 38: Power Seat Circuit

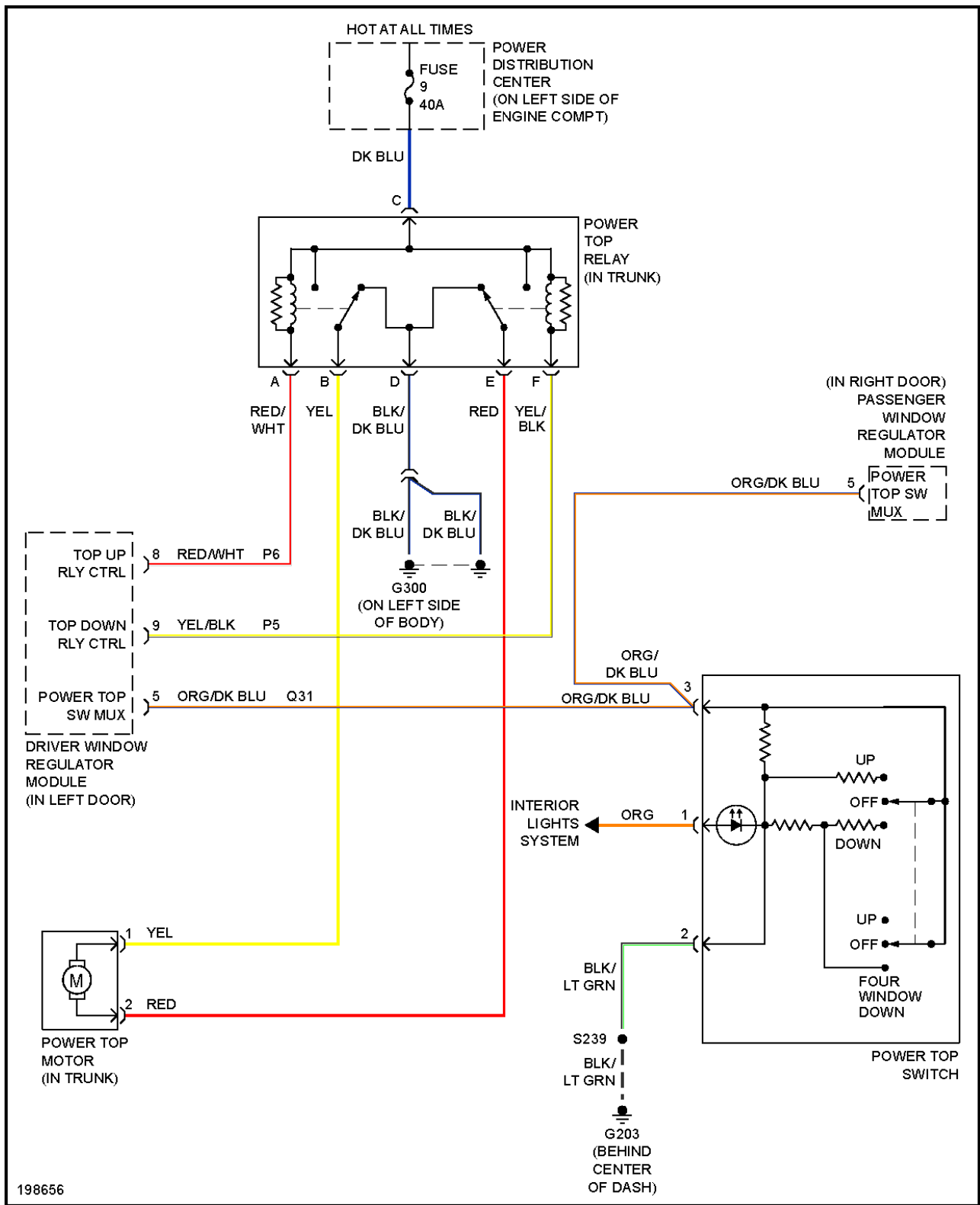

Fig. 39: Convertible Top Circuit

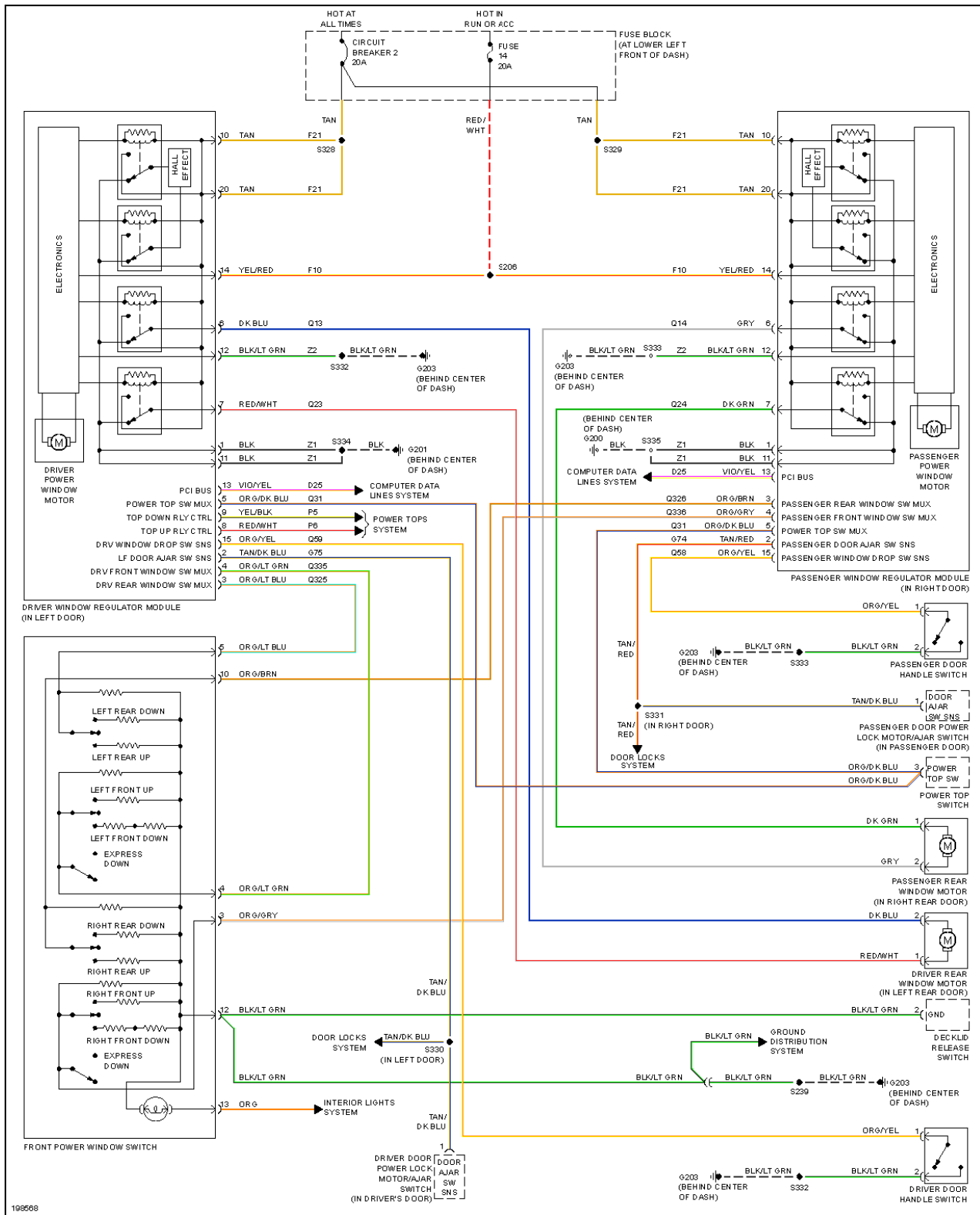

Fig. 41: Power Windows Circuit, Convertible

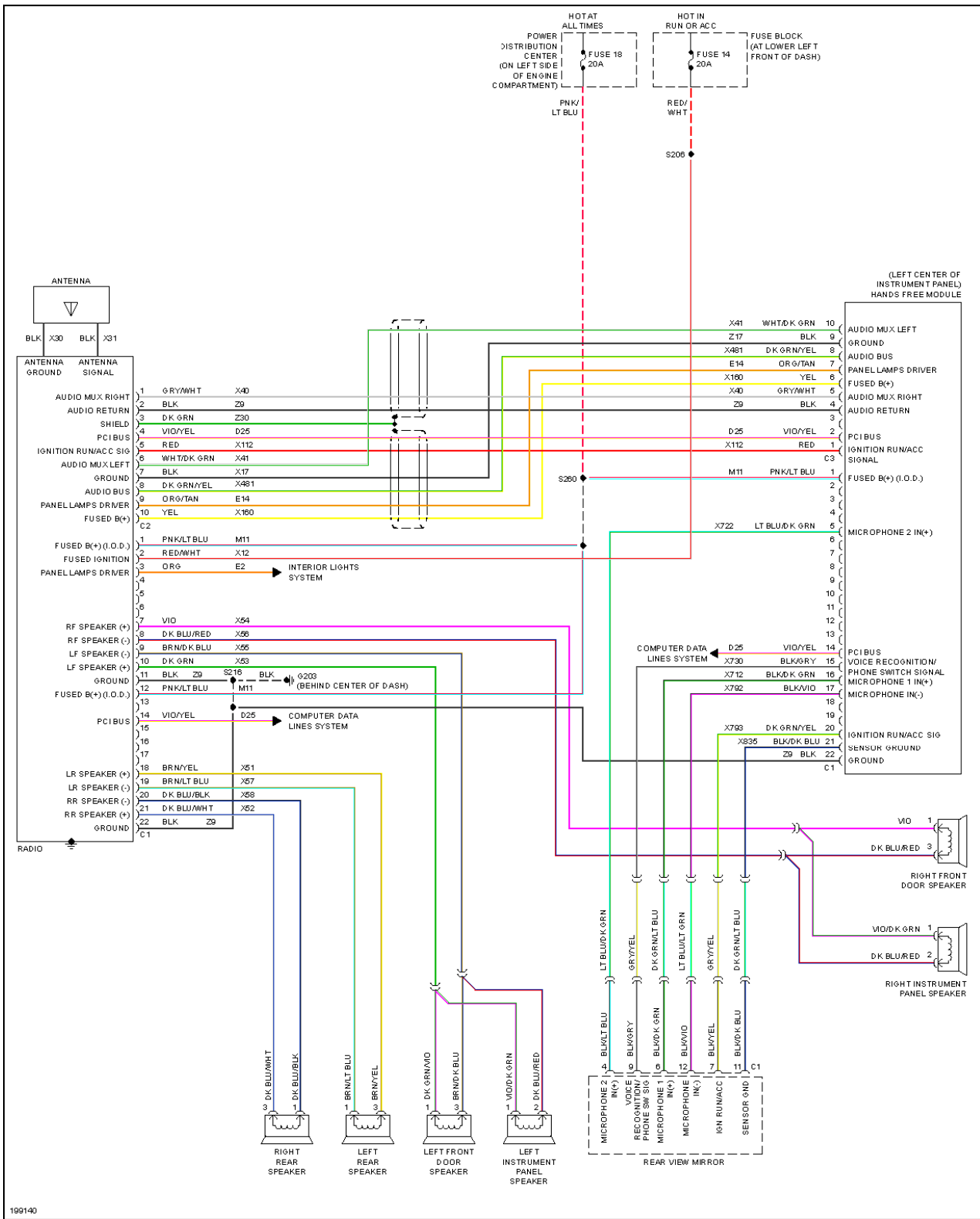

Fig. 43: Radio Circuit, Convertible Base Radio W/ Hands Free

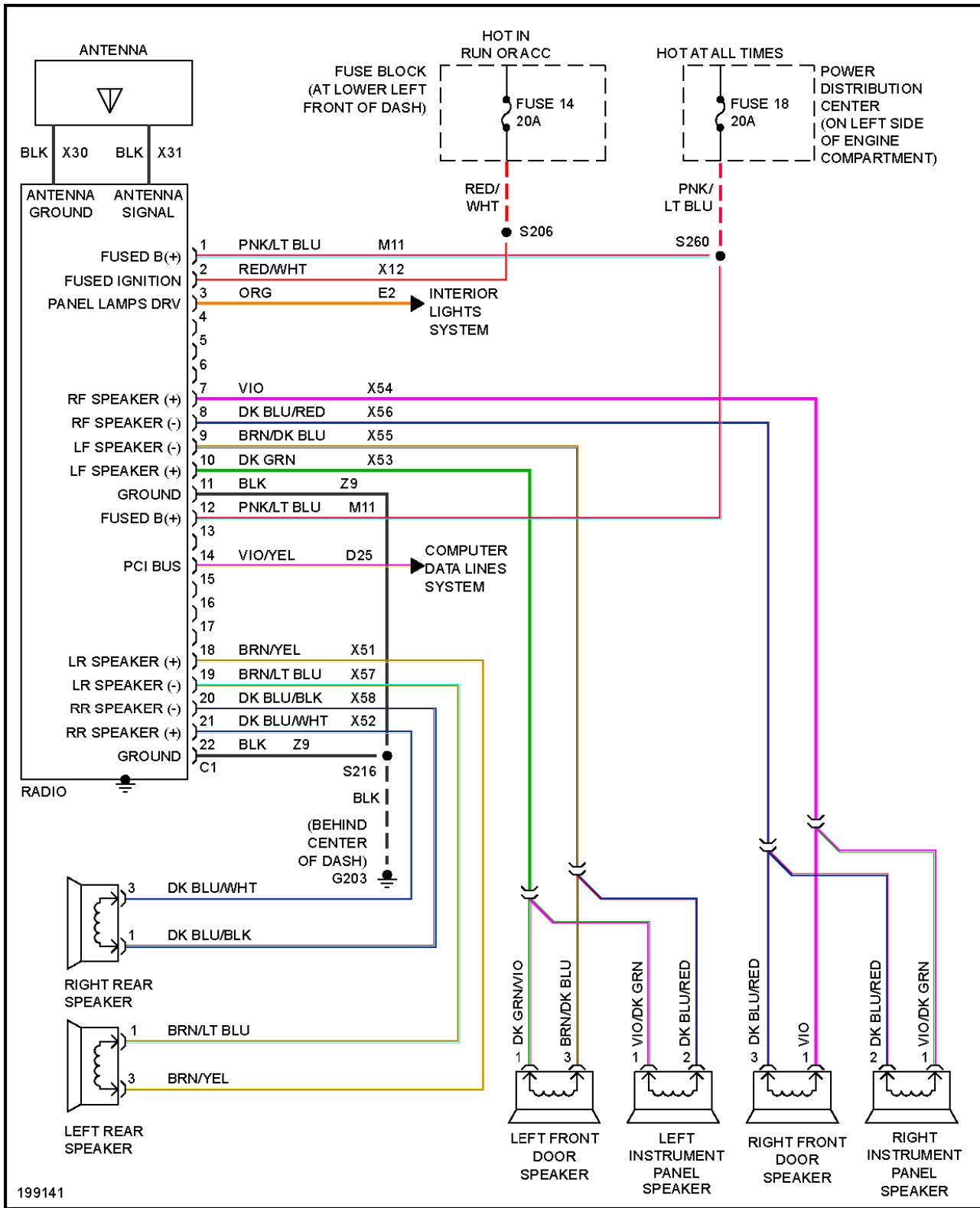

Fig. 44: Radio Circuit, Convertible Base Radio W/O Hands Free

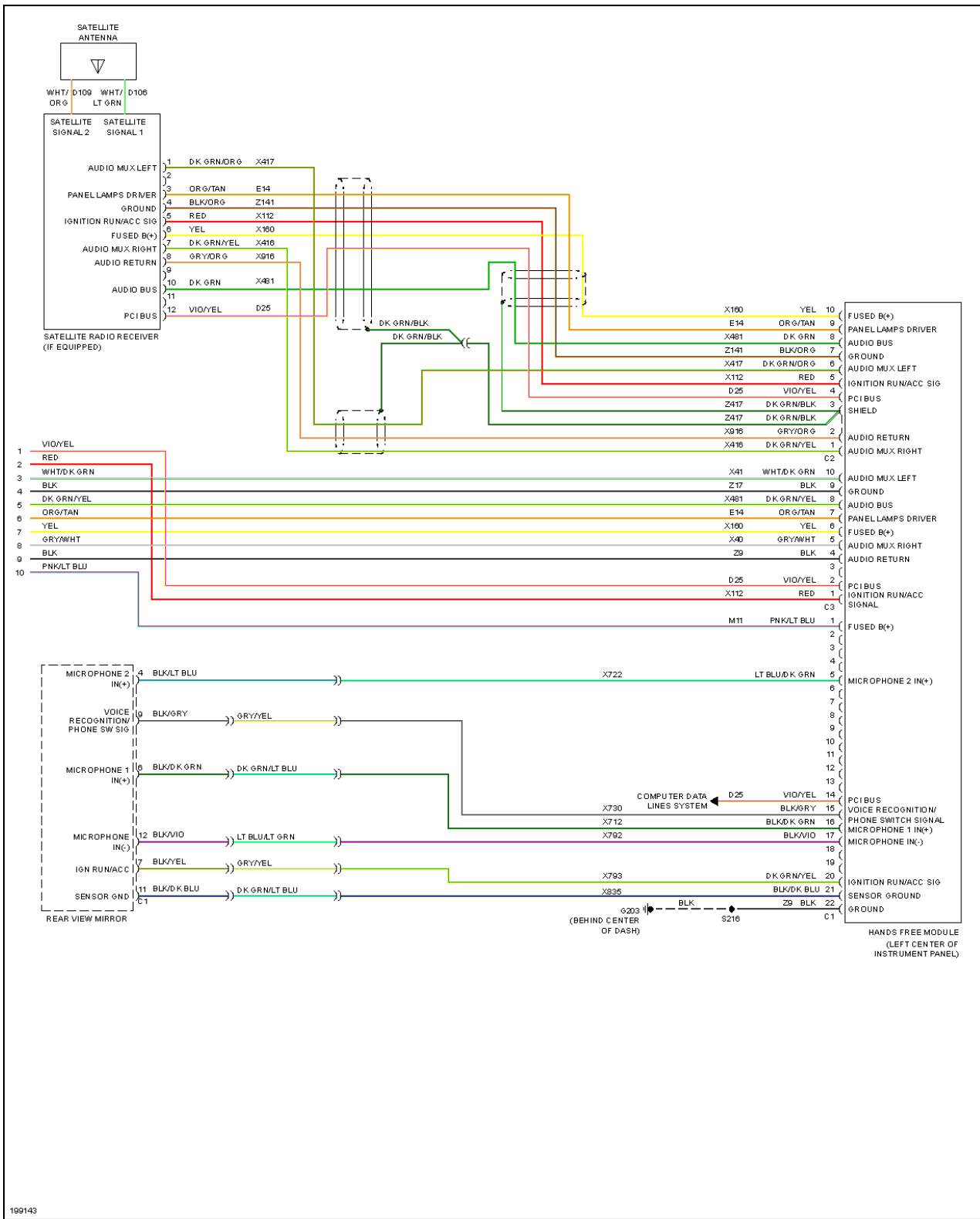

Fig. 46: Radio Circuit, Convertible Premium Radio W/ Hands Free (2 of 2)

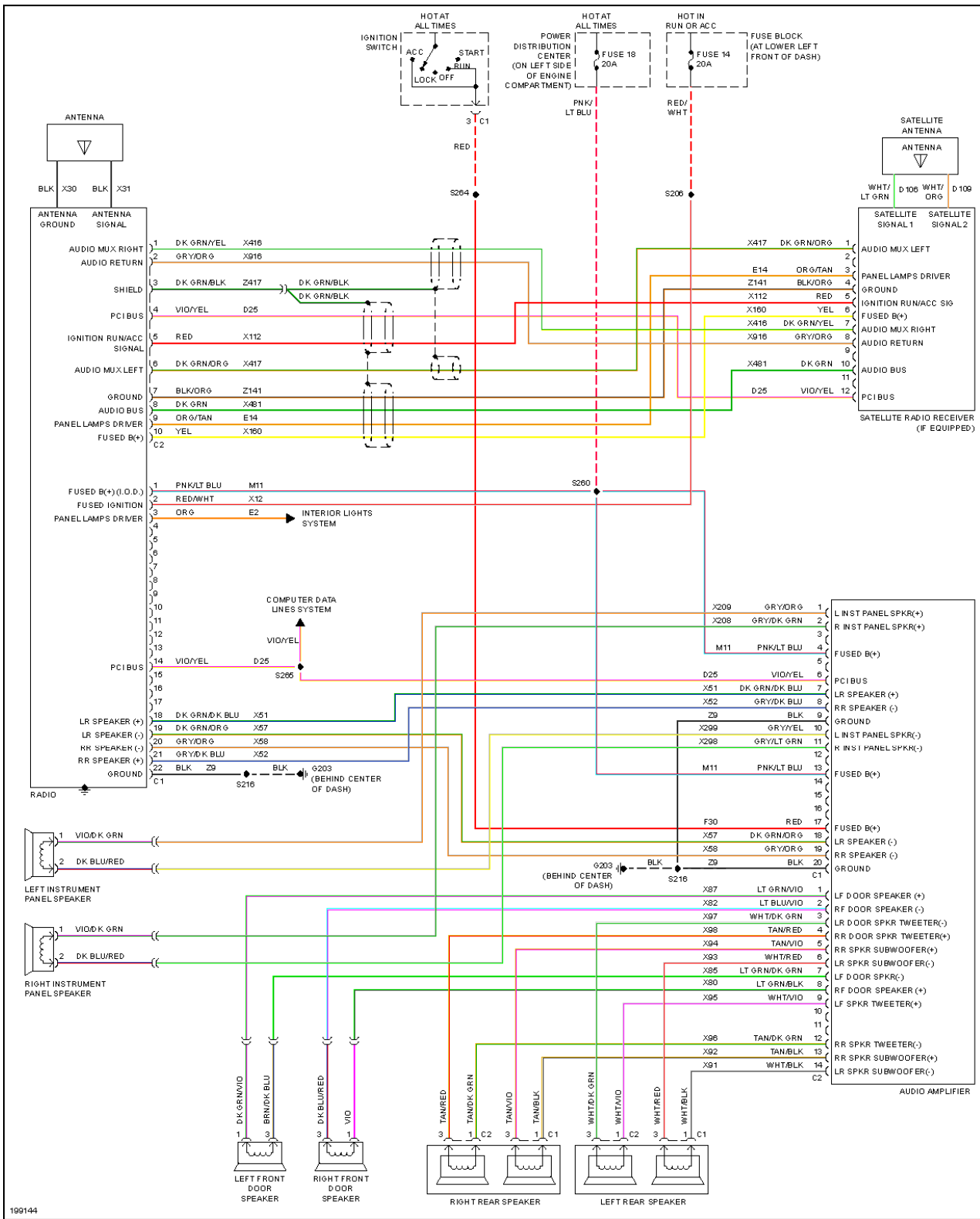

Fig. 47: Radio Circuit, Convertible Premium Radio W/O Hands Free

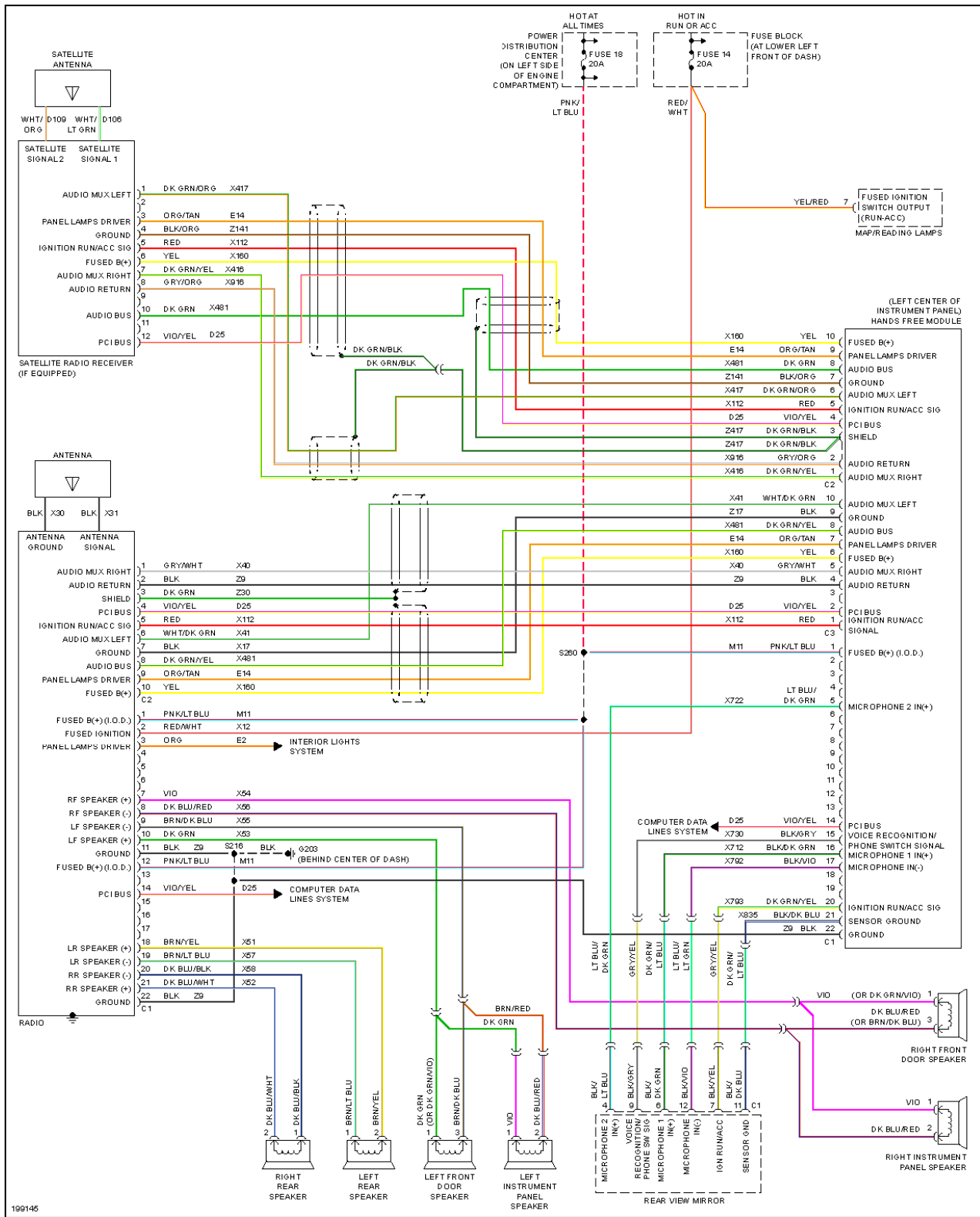

Fig. 48: Radio Circuit, Except Convertible W/ Hands Free

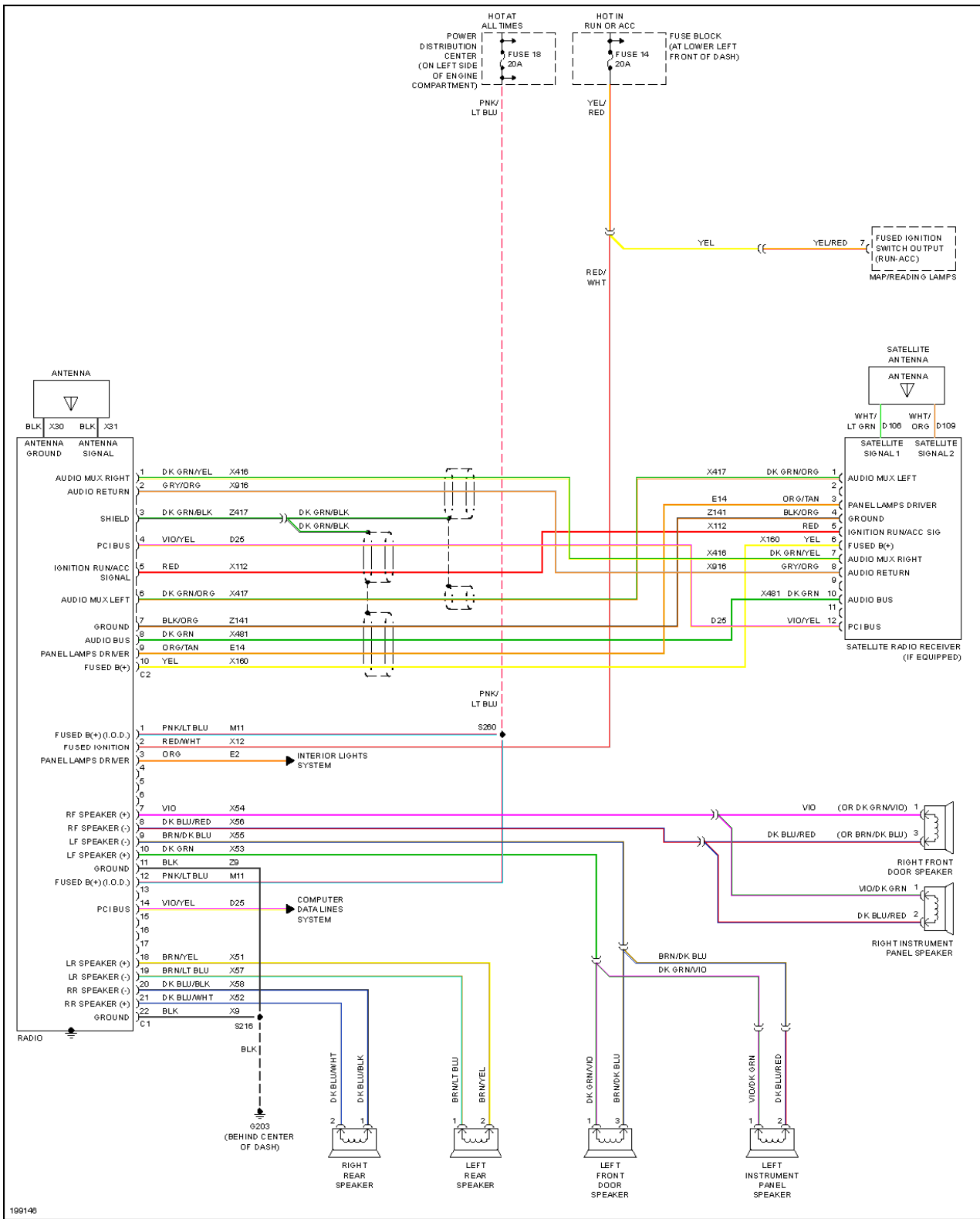

Fig. 49: Radio Circuit, Except Convertible W/O Hands Free

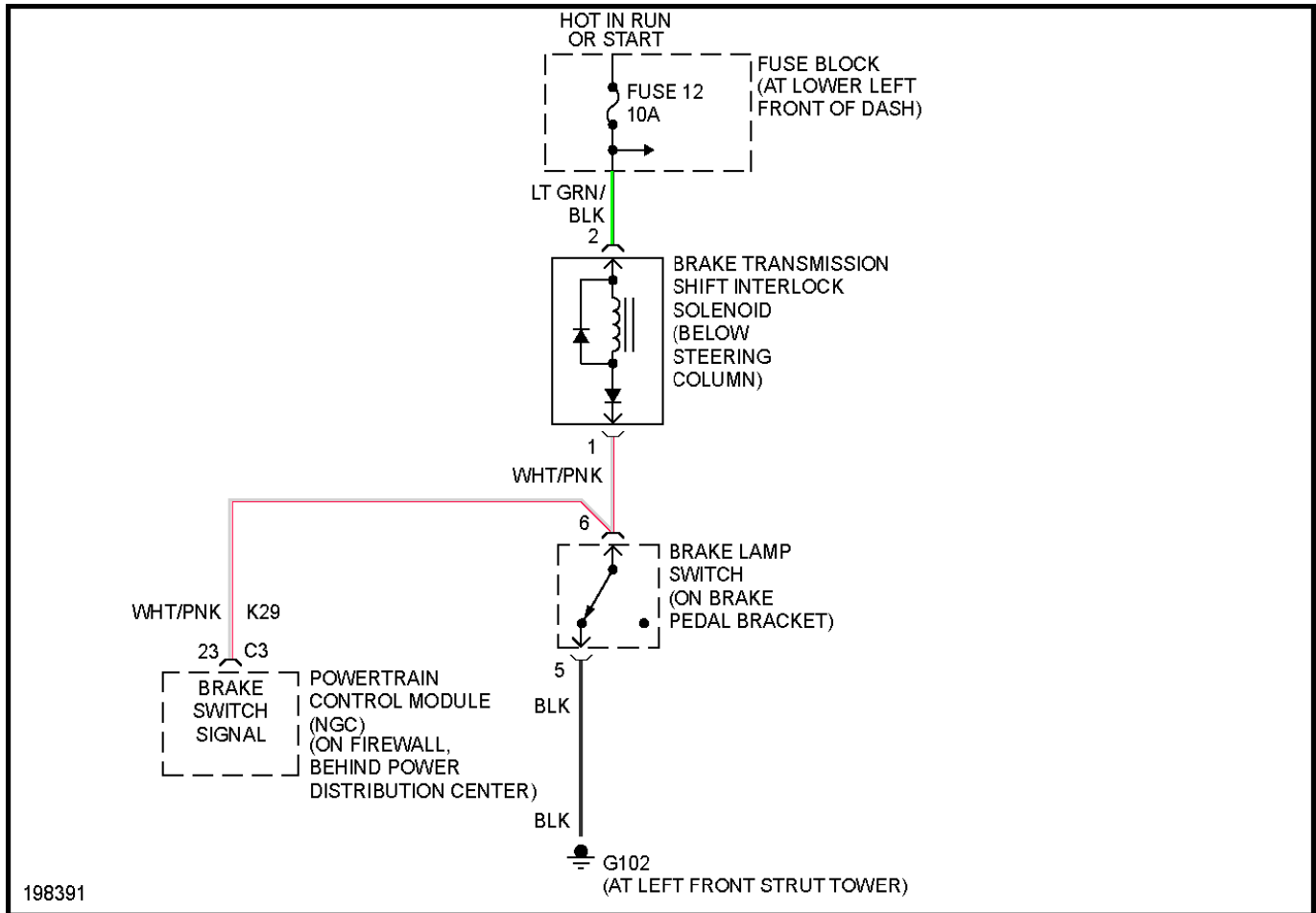
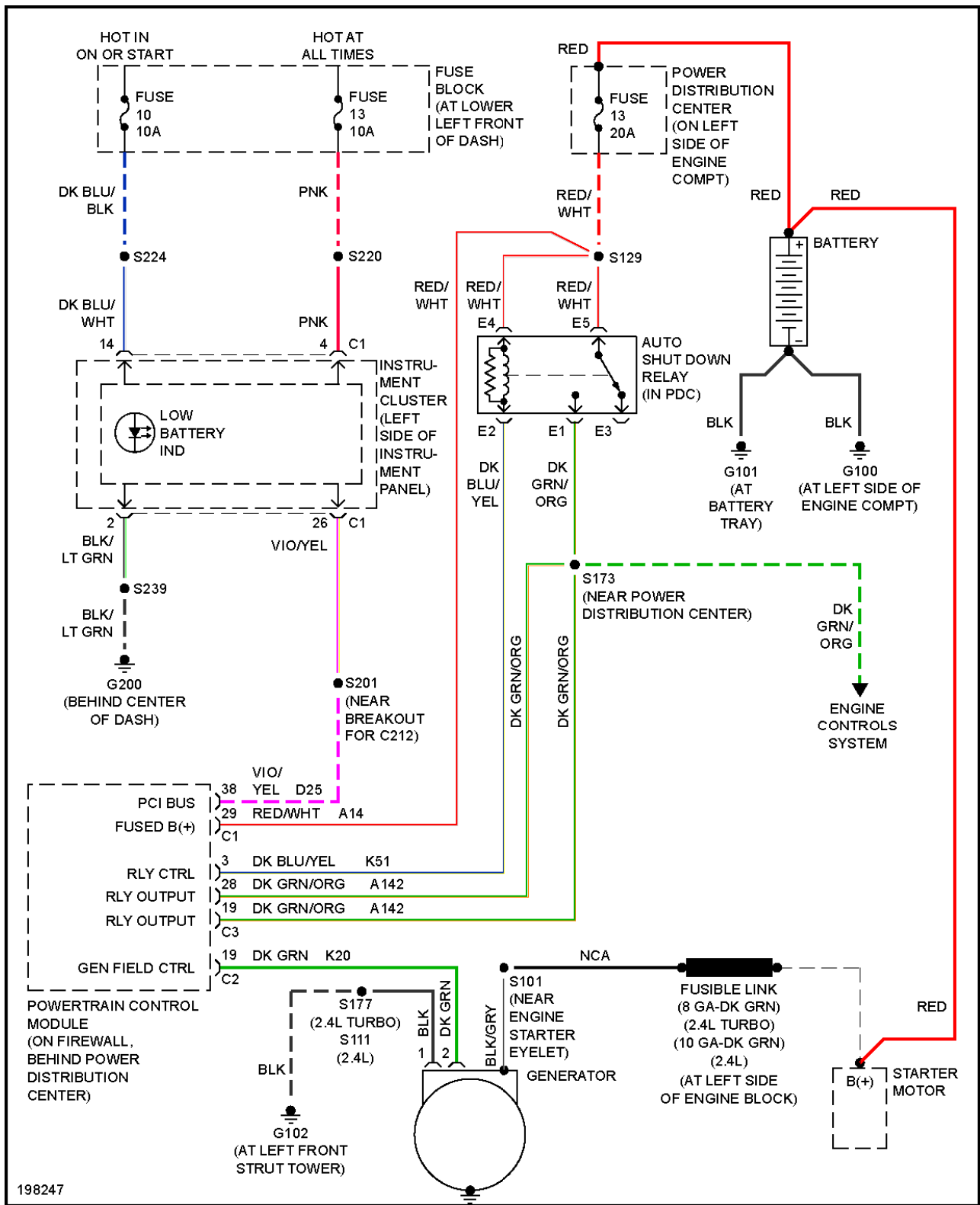
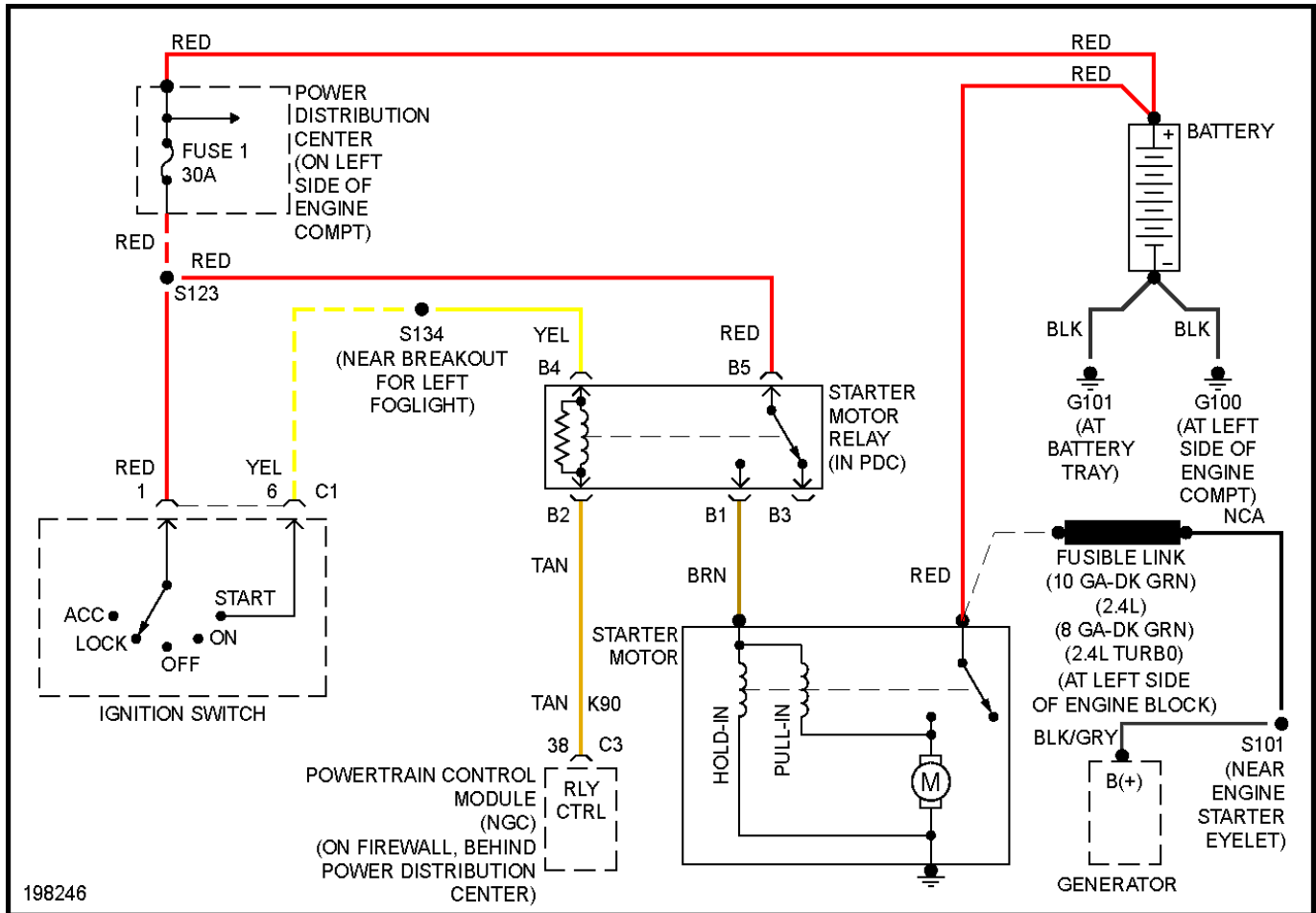

Fig. 50: Shift Interlock Circuit



198247

Fig. 51: Charging Circuit



198246

Fig. 52: Starting Circuit

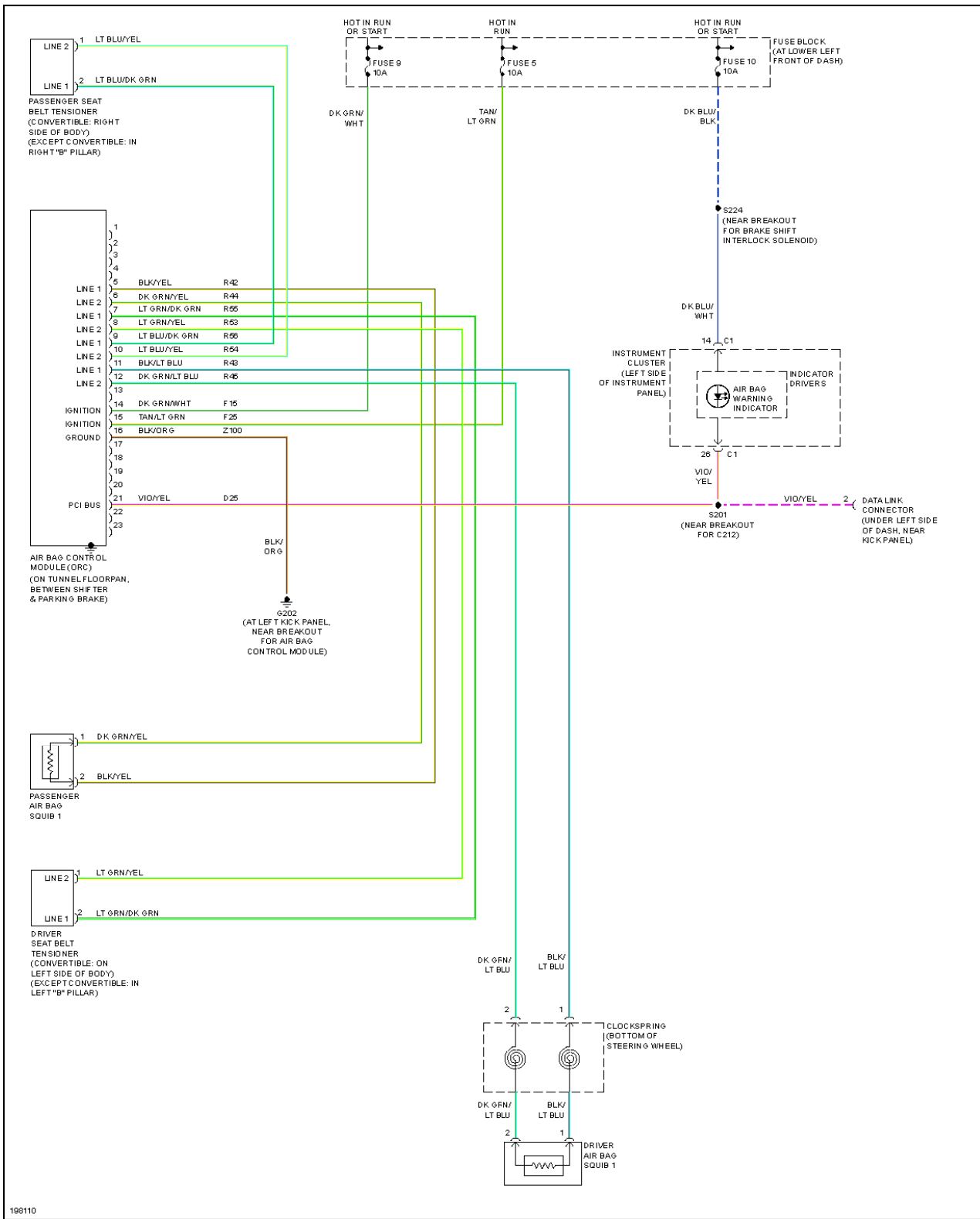

Fig. 53: Supplemental Restraints Circuit, Base

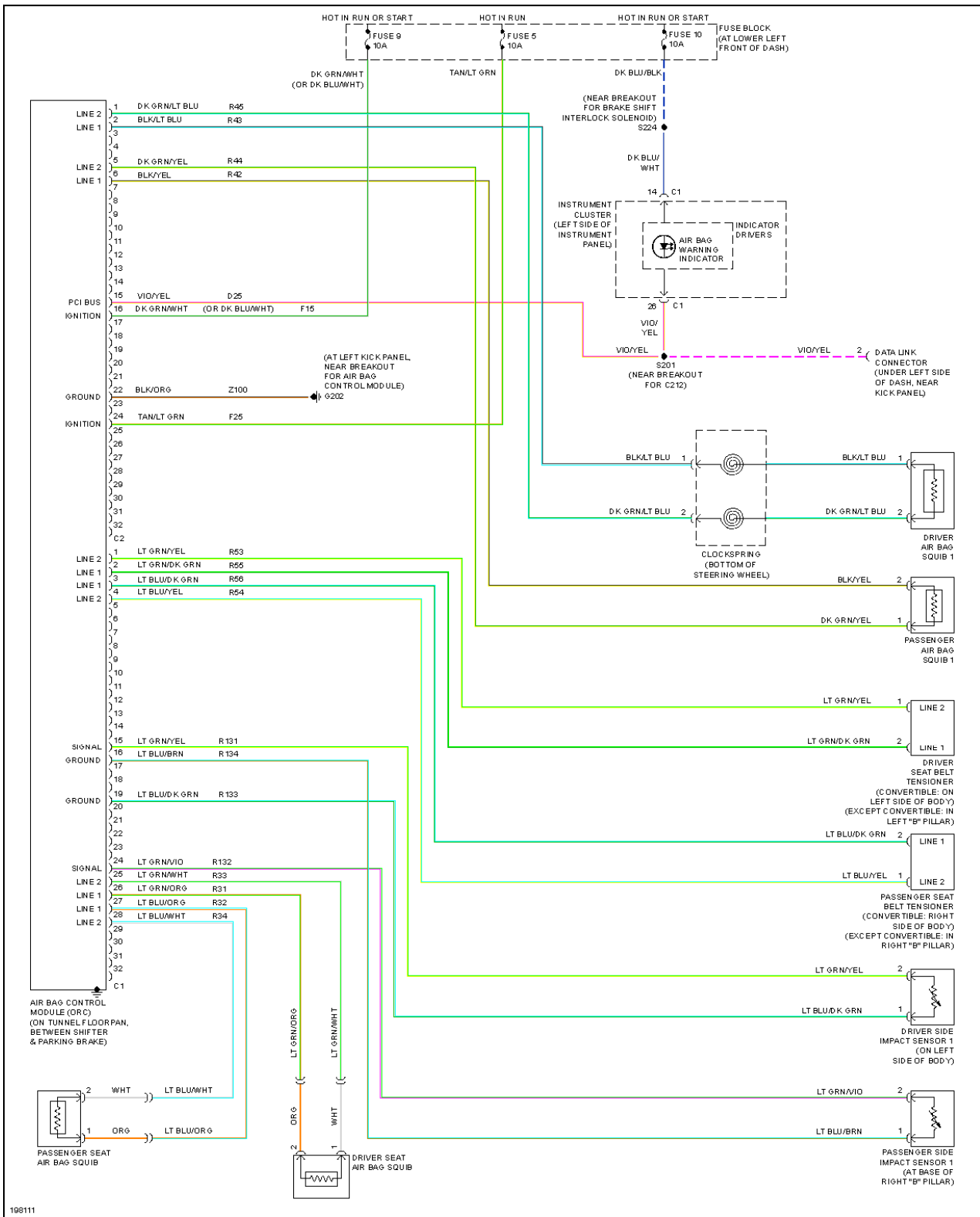

Fig. 54: Supplemental Restraints Circuit, Premium

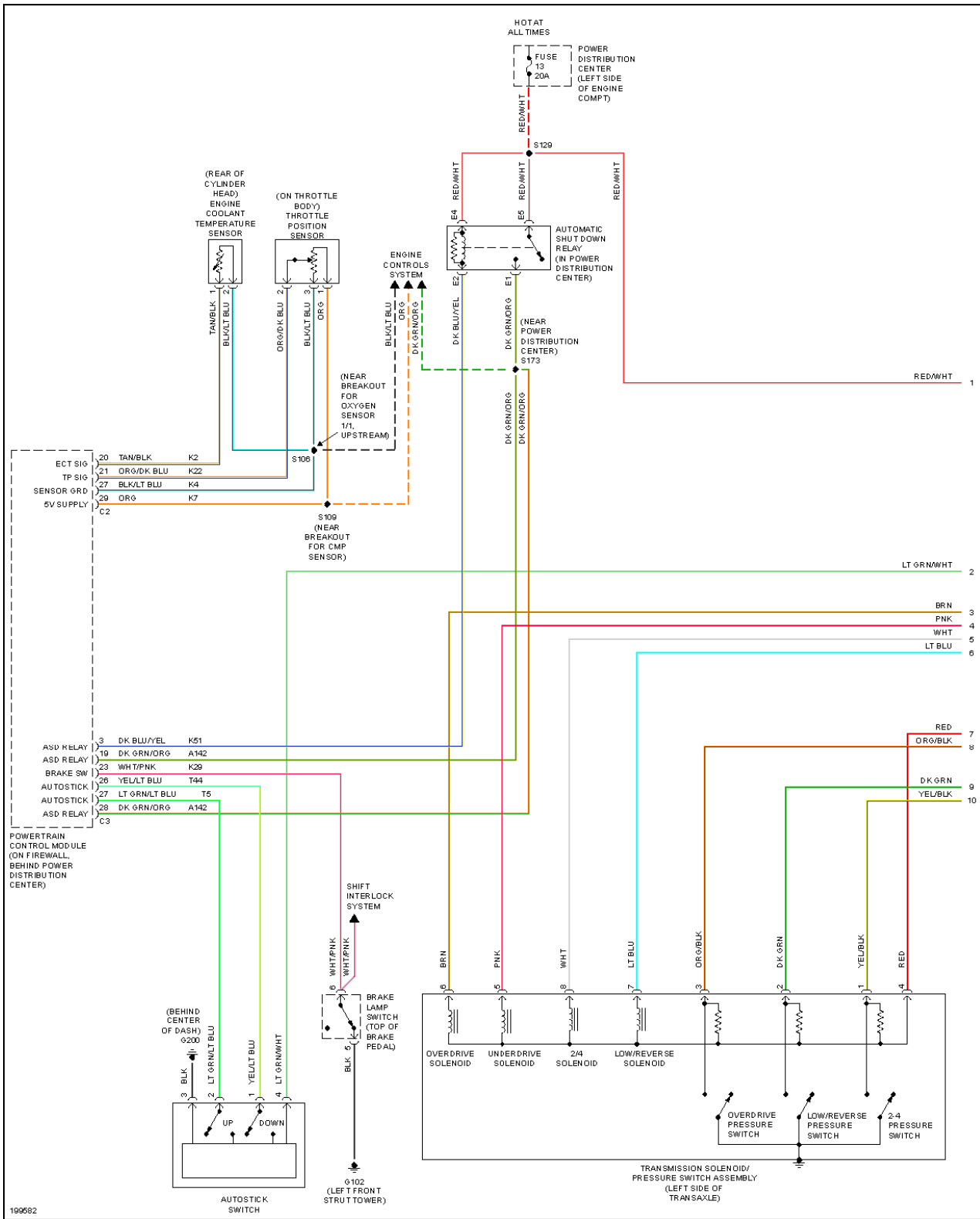

Fig. 55: 2.4L, A/T Circuit (1 of 2)

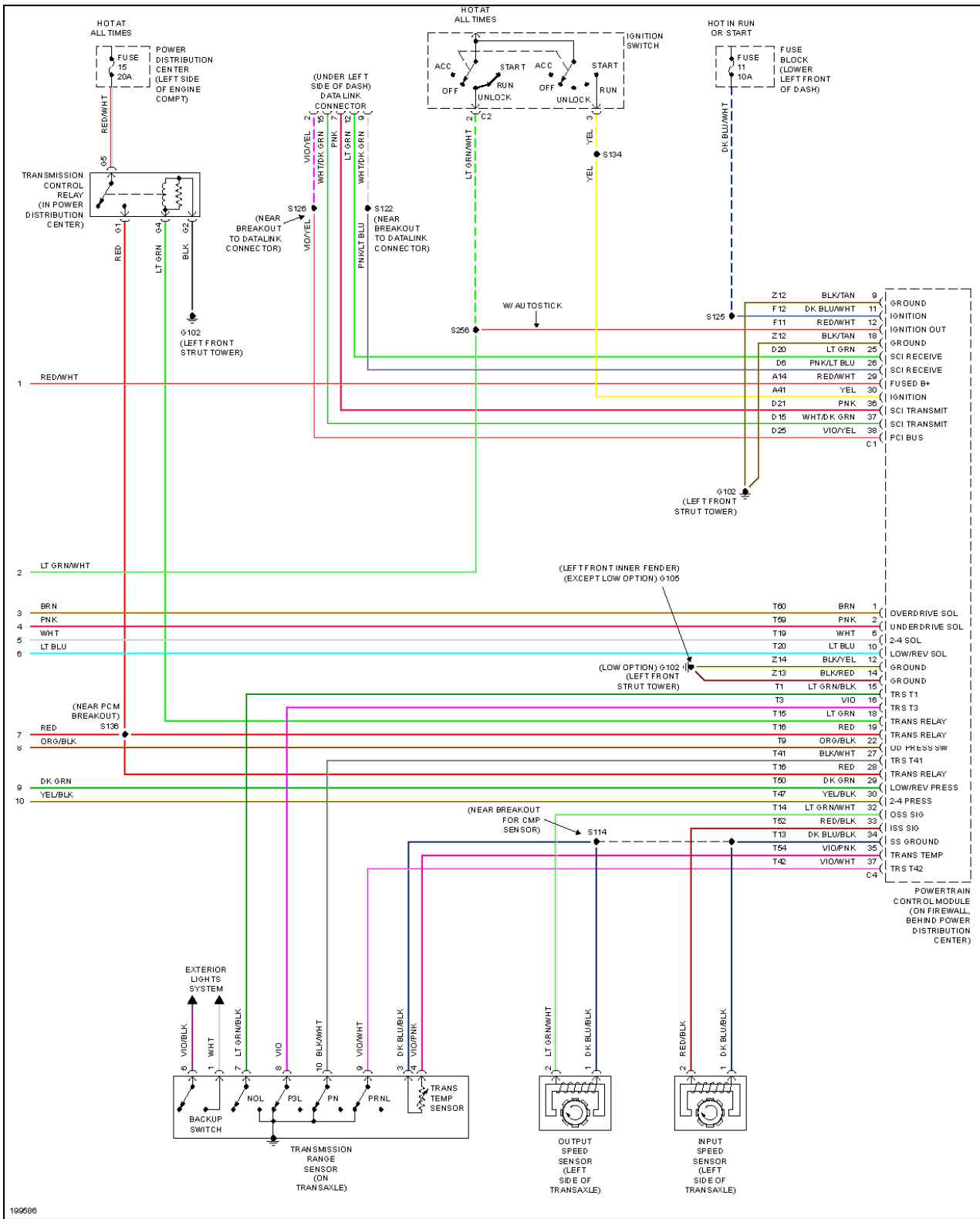

Fig. 56: 2.4L, A/T Circuit (2 of 2)

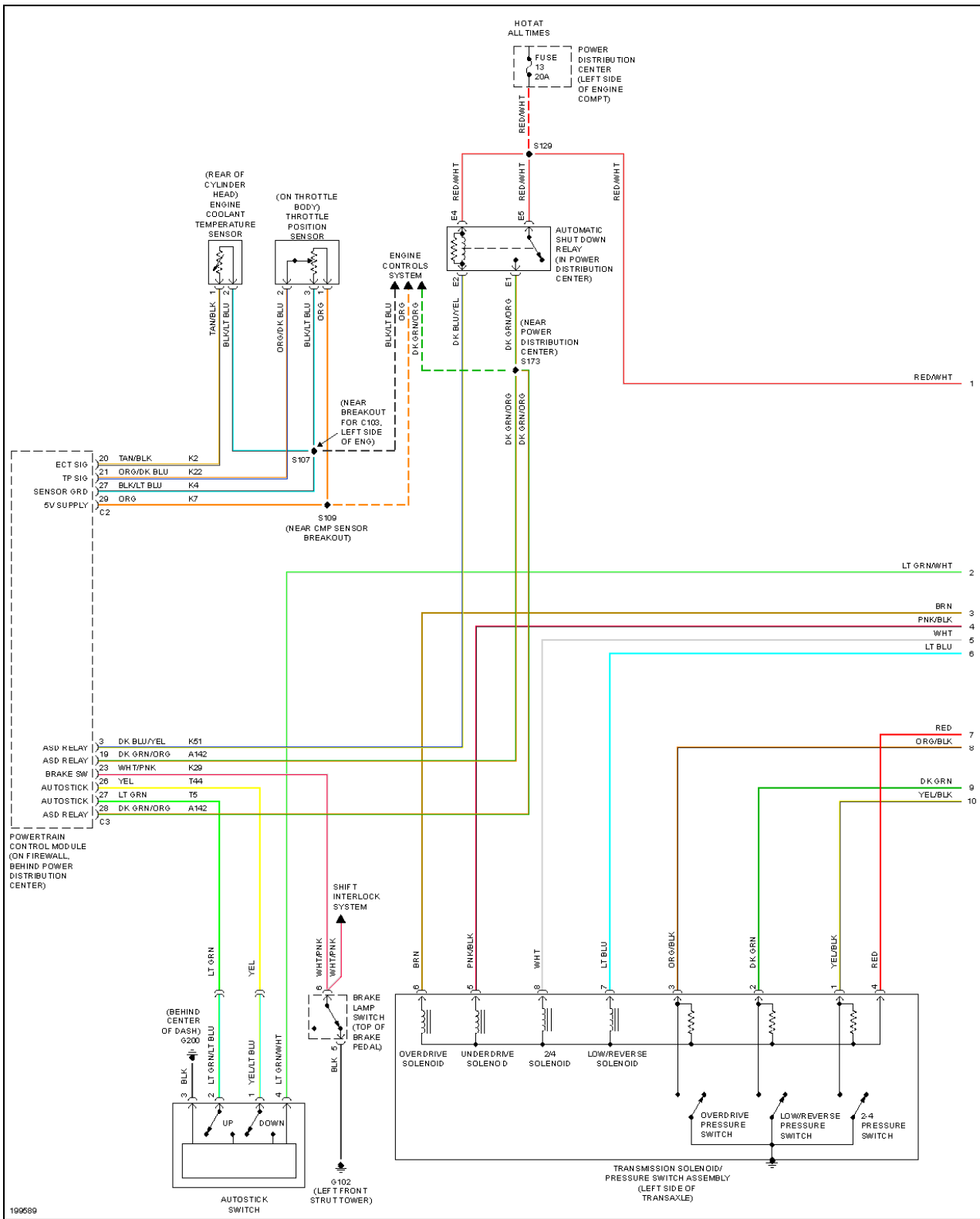

Fig. 57: 2.4L Turbo, A/T Circuit (1 of 2)

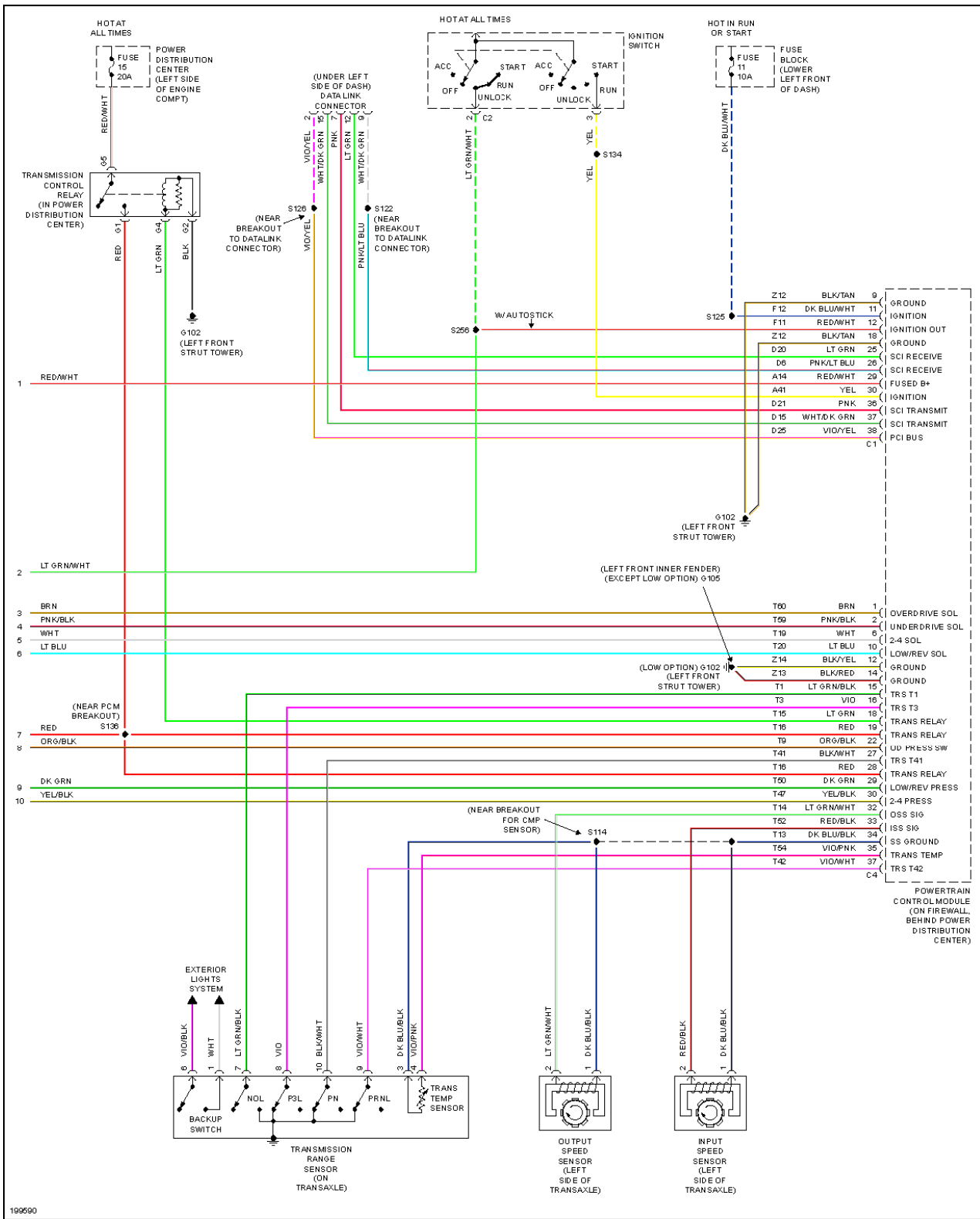
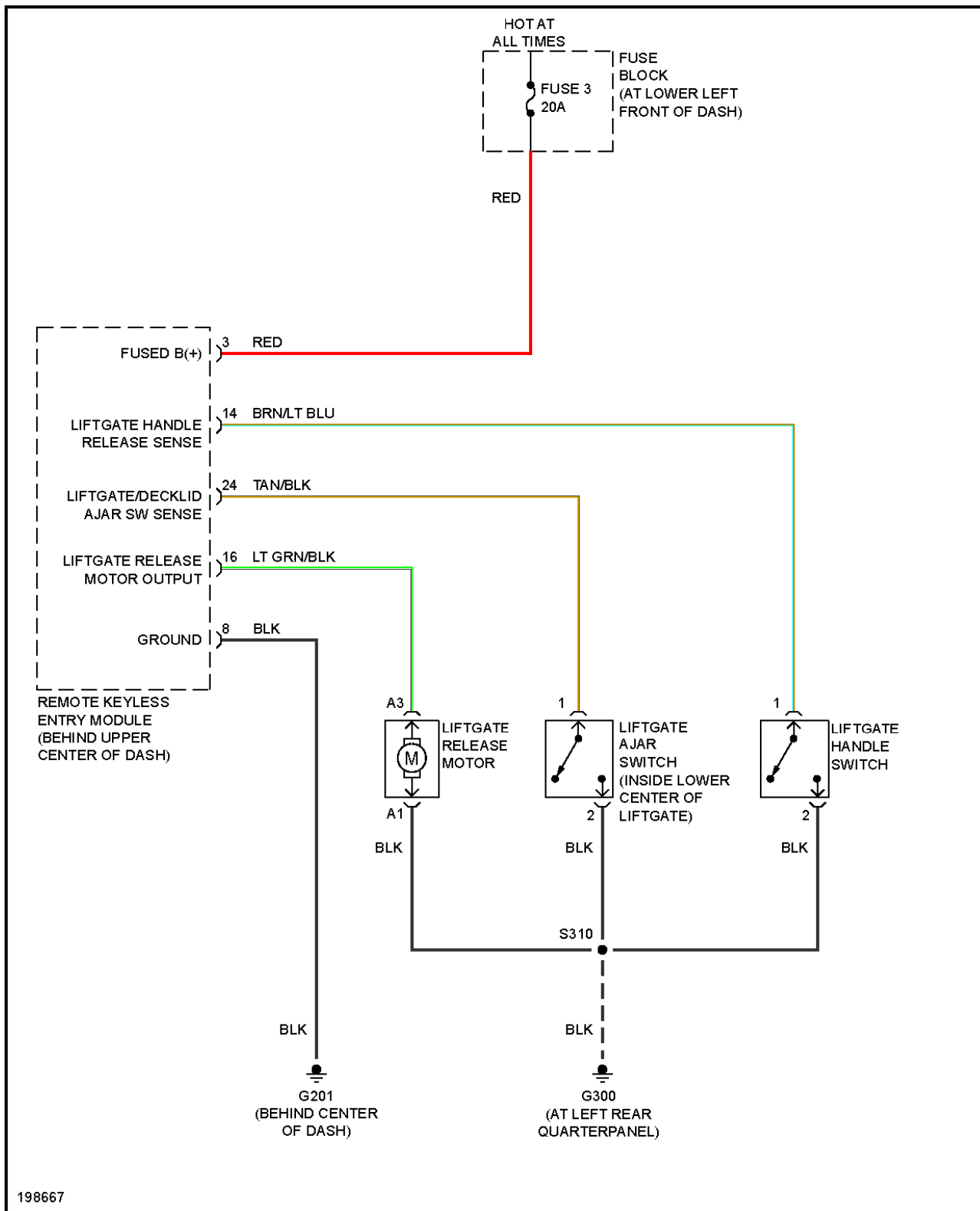

Fig. 58: 2.4L Turbo, A/T Circuit (2 of 2)



198667

Fig. 59: Liftgate Release Circuit, Except Convertible

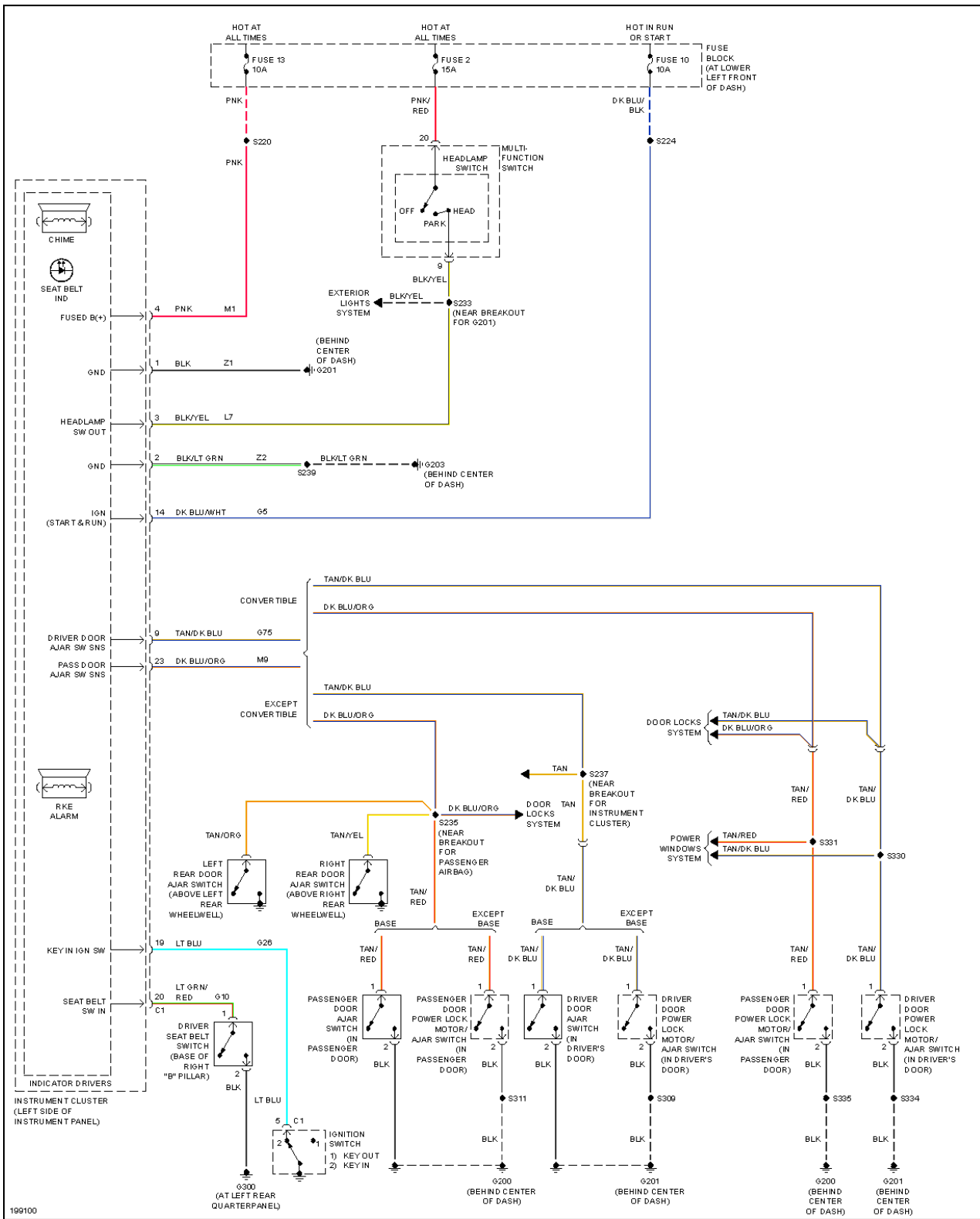

Fig. 60: Warning Systems Circuit

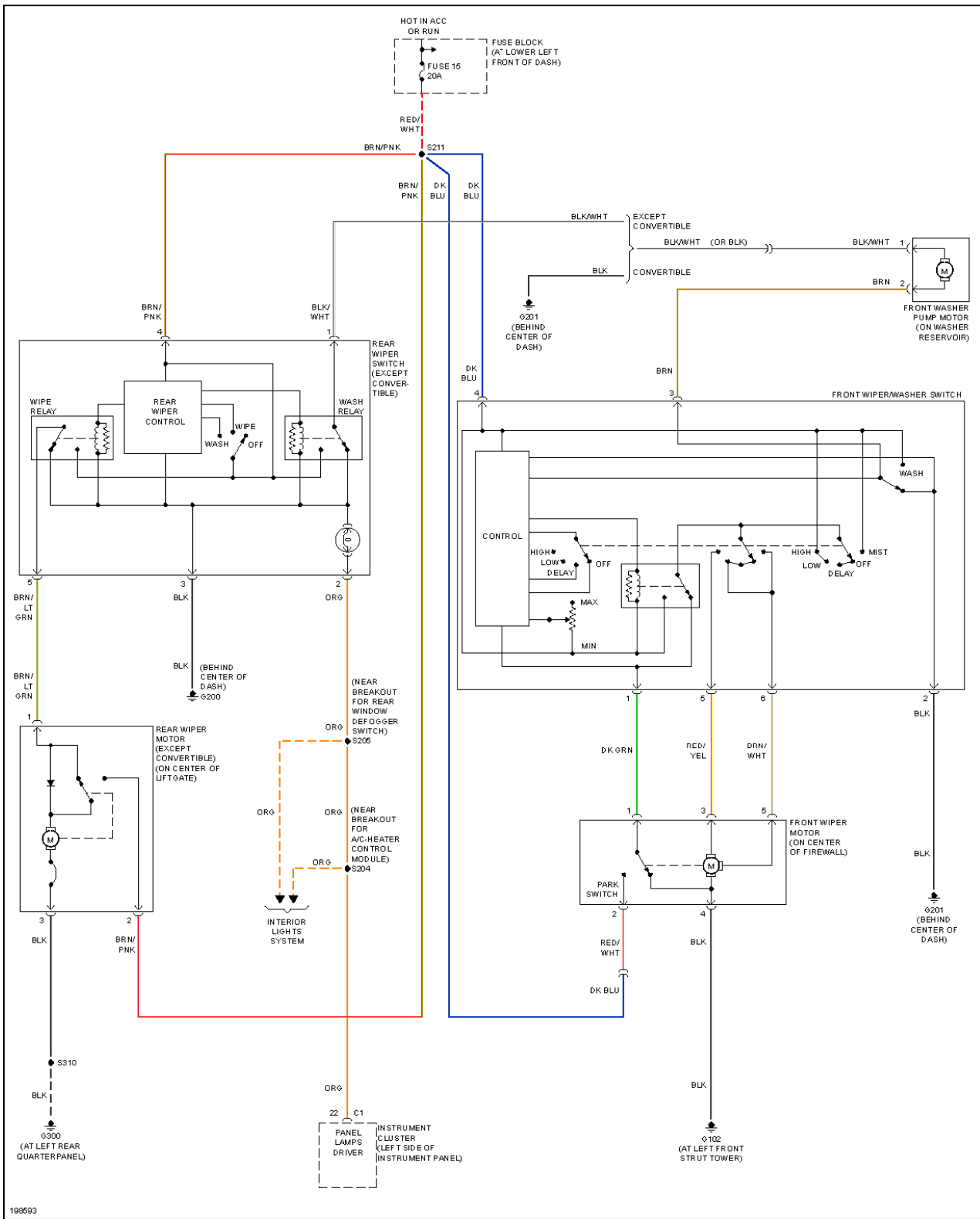

Fig. 61: Wiper/Washer Circuit