

GENERAL NOTES:

THIS SYSTEM SHALL BE INSTALLED IN ACCORDANCE WITH:

- NFPA 17A
- THE LOUISIANA STATE FIRE MARSHAL'S OFFICE
- THE MANUFACTURER'S SPECIFICATIONS
- ALL NOZZLES PROVIDED WITH NOZZLE CAPS
- HOOD CANOPY BY CAPTIVE AIR
- DRAWING NOT TO SCALE
- UTILIZING 5 OF 5 FLOW POINTS
- ALL SUPPLY LINE TO BE 3/8" BLACK SCHEDULE 40 PIPE
- ALL BRANCH LINE TO BE 3/8" STAINLESS STEEL PIPE WHERE EXPOSED

SYSTEM DETAIL

BLACK SCHEDULE 40 PIPING

3/8" E.M.T. WITH 1/16" S.S. CABLE

1/4" PNEUMATIC ACTUATION TUBING

BILL OF MATERIALS

QTY.	NAME
1	R-102-1.5-GALLON PEG RELEASE
1	R-101-10 FIRING CARTRIDGE
1	AUTOMATIC FUEL SHUT-OFF VALVE
1	IN PLENUM 10' MAX
1	ANSUL REMOTE PULL
1	DPDT MICROSWITCH
1	3W DUCT 51-100
1	IN GRPL 36" X 30" @ 35" - 40"
1	IN CHPRL 36" X 24" @ 15" - 40"
1	ANSUL AUTOMATIC DETECTOR
1	PNEUMATIC GAS PISTON
1	ANSUL 1 1/2-GALLON CYLINDER

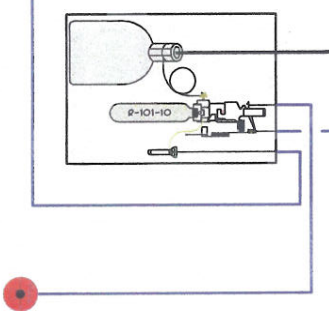
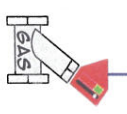
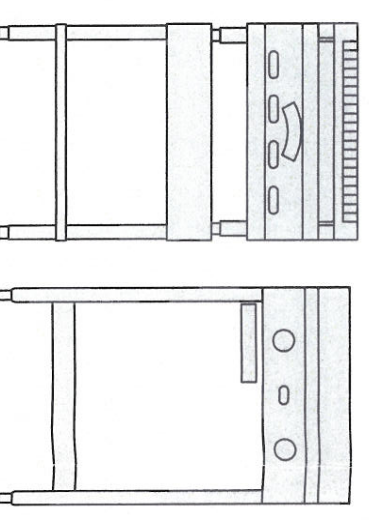
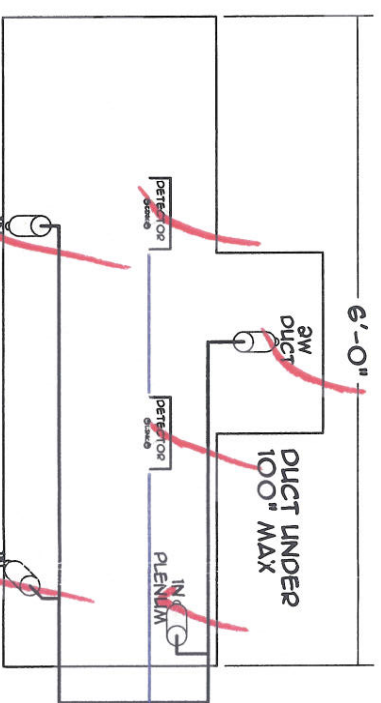
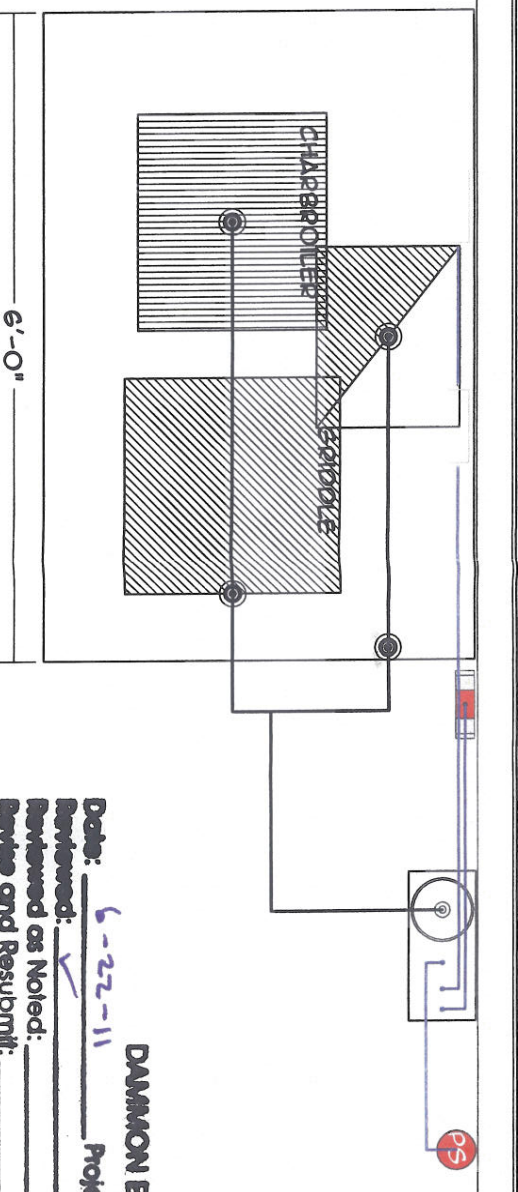

DATE: 6-22-11
PROJECT: SMH - Cafeteria
REVIEWED AS NOTED: [checked]
REVIEWED AND RESUBMITTED:
REJECTED:
OTHER:

Corrections or comments made on the shop drawings during this review do not relieve the contractor from compliance with requirements of the drawings and specifications. This check is only for review of the general conformance with the design concept of the project and general compliance with the information given in the contract documents. This contractor is responsible for: confirming and correlating all quantities and dimensions; selecting fabrication processes and techniques of construction; coordinating his or her work with that of all other trades and performing all in a safe and satisfactory manner.

Submitted Item: Hood Suppression System
Comments:

400379

REVIEWED FOR
 STATE FIRE MARSHAL
 AS PER REVIEW LETTER
 BY RON C. MATTHIS

SLIDELL MEMORIAL HOSPITAL
 1001 GAUSE BLVD
 SLIDELL, LA 70458-2987

ANSUL
 R-102-1.5-GALLON
 WET CHEMICAL
 UL 300 LISTED

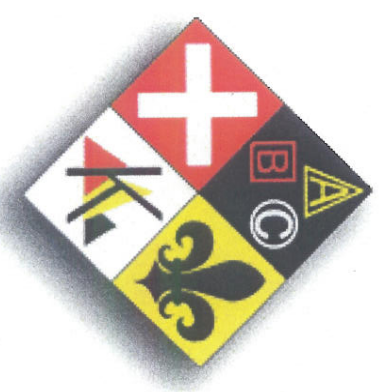

FIRE AND SAFETY
 COMMODITIES
 999 INDUSTRY ROAD
 KENNER, LA 70062
 FRIM: F58
 OFFICE: (504) 465-5944
 FAX: (504) 465-5948
 WWW.FIRESAFETYINC.NET
 BY: MACE BOURGEOIS
 LIC. #: E383
 MACE@FIRESAFETYINC.NET