

Calibration Column

DESCRIPTION

Milton Roy test tube Calibration Columns are designed specifically for use in determining flow rates of chemical metering pumps. Pump flow rate verification on periodic basis or after maintenance is important to system accuracy.

The test tube Calibration Columns provide a fast, easy, economical means of checking flow rates of your chemical metering pump. The units are easily installed (see instructions and diagram on reverse side).

Test tube Calibration Columns are available in the six sizes shown below. Flow rates shown below are based on a 30 second sample time.

- 60 ml . . . for pumps up to 2.0 GPH
- 100 ml . . . for pumps up to 3.3 GPH
- 250 ml . . . for pumps up to 8.3 GPH
- 500 ml . . . for pumps up to 16 GPH
- 1000 ml . . for pumps up to 34 GPH
- 2000 ml . . for pumps up to 67 GPH
- 4000 ml . . for pumps up to 120 GPH

FEATURES

- Rugged PVC materials of construction
- Large, easy to read label with operating instructions for ease of use
- Graduated in ml and standard divisions -- no conversion needed
- Easy to Clean
- Available from stock



DIMENSIONS

Model Number	Capacity	A	B	C
TT-0060	60 ml	13-3/4"	1-5/16"	1/4" Female NPT
TT-0100	100 ml	14-3/8"	1-5/8"	1/2" Female NPT
TT-0250	250 ml	15-3/4"	2-1/4"	1/2" Female NPT
TT-0500	500 ml	17-3/16"	2-3/4"	3/4" Female NPT
TT-1000	1000 ml	27-1/16"	2-3/4"	3/4" Female NPT
TT-2000	2000 ml	21-1/4"	5"	2" Female NPT
TT-4000	4000 ml	31"	5"	2" Female NPT

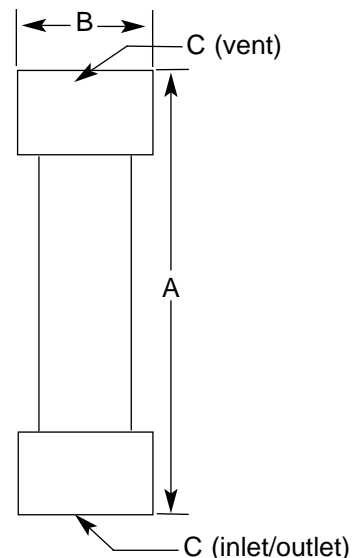

INSTALLATION INSTRUCTIONS

The recommended installation is shown below.

1. Install the test tube in the suction line to the chemical feed pump. The test tube should be installed in a vertical position, adjacent to the chemical storage tank. The test tube is filled by gravity; therefore, the tank must be full, or nearly full, in order to use the test tube.
2. Two (2) ball valves are required and must be installed as shown below. Valves are not included with the test tube, but may be purchased from Milton Roy.
3. A return (overflow) line must be provided, connection the top of the calibration column to supply tanks. Do not install any valve in this overflow line, as the test tube must be vented to atmosphere at all times.
4. A support strap is provided with each test tube for added stability at the top if needed.

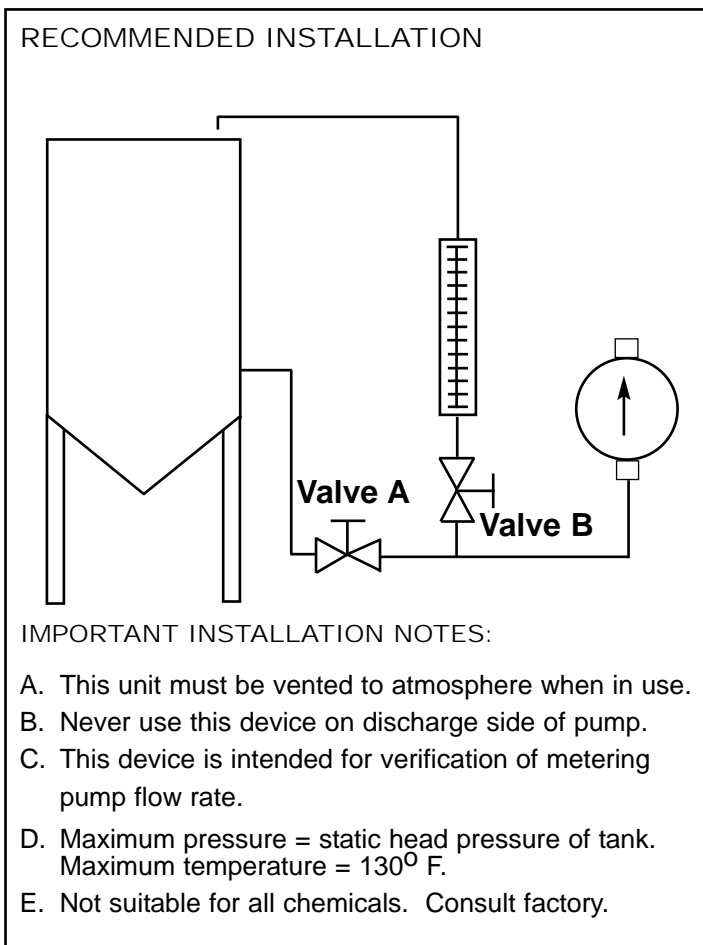

OPERATING INSTRUCTIONS

A stop watch or standard wrist watch with sweep second hand is required.

1. With the pump operating normally, storage tank full or nearly full, and both valve A and valve B in the full open position, the test tube will fill with liquid.
2. When the liquid level reaches the zero division mark, close valve A. (Any division mark may be used as a starting point; however, by filling to the zero mark, you may measure over a longer period of time, enabling you to get a better calibration.)
3. Allow liquid level to drop for a period of at least 309 seconds before reopening valve A. (It is simplest to reopen valve A when liquid level is at one of the division lines.)
4. Finally, divide the number of divisions that the liquid has dropped by the number of minutes used. The answer is the pump flow rate in gallons per hour (GPH). For TT-4000 only, divide the number of divisions that the liquid has dropped by the number of minutes used and multiply the answer by ten. The answer is the pump flow rate in gallons per hour (GPH).
5. Example: Using the TT-1000 unit, the liquid level drops from the zero division to the 10th division in 30 seconds (0.5). The flow rate, then, is $10 / 0.5 = 20.0$ GPH.
6. Check the actual measured flow rate against the setting on the pump.
7. When the test tube is not in use, valve B may be closed.
8. Valve A must remain open at all times except while the test tube is in use.

NOTE:

With both valves in the open position, the test tube may be used as a level gauge. This practice should only be followed when process liquid level is below the maximum calibration column height. If liquid level is higher than maximum calibration column height, the calibration column will overfill and force the process liquid to return to the tank.

AVAILABLE ACCESSORIES:

In addition to metering pumps & chemical feed systems, Milton Roy offers the following accessories:

- Back Pressure Valves
- Pulsation Dampeners
- Gauge Glasses
- Valve Actuators
- Safety Valves
- Dissolving Baskets
- Pressure Gauges
- Floats
- Tanks
- Mixers
- Traps

Milton Roy Company • Flow Control Division

201 Ivyland Road • Ivyland, PA 18974-0577 • 215-441-0800 • FAX: 215-441-8620 • www.miltonroy.com

This document contains proprietary information of Milton Roy Company. Neither receipt nor possession thereof confers any right to reproduce, modify, use, or disclose, in whole or in part, any such information without written authorization from Milton Roy Company. Please reference Milton Roy General Terms and Conditions of Sale.

Milton Roy Company owns all trademarks and registered trademarks of products listed.

AD 4331

Effective 9/1/99