

SUR/SUL/HSUR/HSUL

Skewed 45° Face-Mount Hangers



This product is preferable to similar connectors because of (a) easier installation, (b) higher loads, (c) lower installed cost, or a combination of these features.

The SU and HSU series of hangers are skewed 45° left or right. Angled nail slots direct nails for proper installation.

Material: SUR and SUL — 16 gauge; HSUR and HSUL — 14 gauge

Finish: Galvanized. Some products available in ZMAX® coating. See Corrosion Information, pp. 13–15.

Installation:

- Use all specified fasteners; see General Notes
- These hangers will normally accommodate a 40° to 50° skew
- Illustration shows left and right skews SUR/L (SUR = skewed right; SUL = skewed left)
- The joist end may be square cut or bevel cut

Options:

- Available with the A₂ flange turned in on the 2-2x and 4x models only (see illustration)
- To order, add “C” (for concealed) to the product name
- For example, specify HSURC46, HSULC46, SURC46, or SULC46

Codes: See p. 12 for Code Reference Key Chart

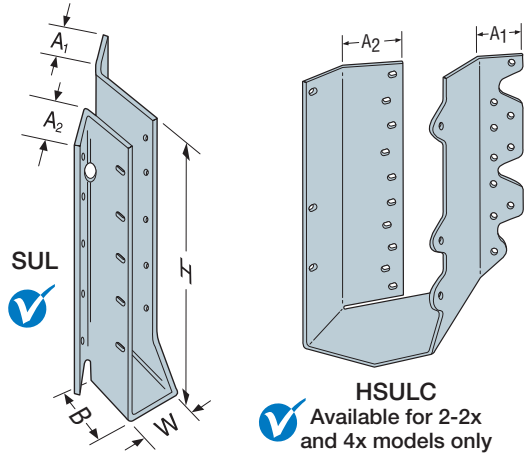

HSULC
Available for 2-2x and 4x models only

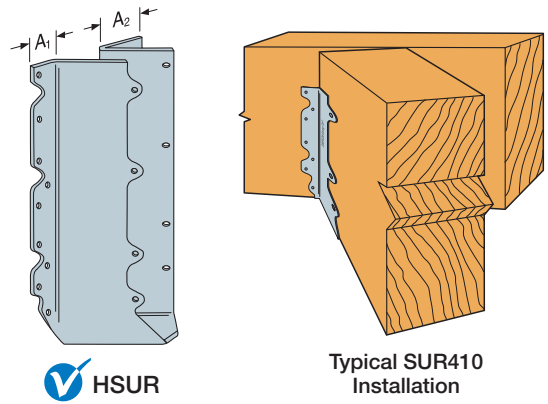

HSUR

Typical SUR410 Installation

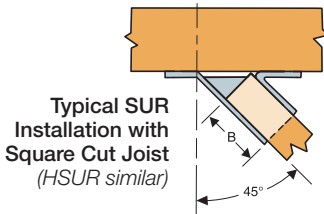

Typical SUR Installation with Square Cut Joist (HSUR similar)

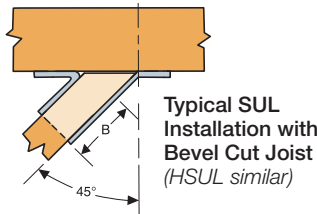

Typical SUL Installation with Bevel Cut Joist (HSUL similar)

These products are available with additional corrosion protection. For more information, see p. 15.

SS For stainless-steel fasteners, see p. 21.

SD Many of these products are approved for installation with Strong-Drive® SD Connector screws. See pp. 336–337 for more information.

Joist Size	Model No.	Dimensions (in.)					Fasteners (in.)		DF/SP Species Header Allowable Loads				SPF/HF Species Header Allowable Loads				Code Ref.
		W	H	B	A ₁	A ₂	Face	Joist	Uplift (160)	Floor (100)	Snow (115)	Roof (125)	Uplift (160)	Floor (100)	Snow (115)	Roof (125)	
2x4	SUR/L24	1 1/16	3 1/2	2	1 1/8	1 1/4	(4) 0.162 x 3 1/2	(4) 0.148 x 1 1/2	395	575	650	705	340	495	560	605	IBC, FL, LA
SS 2x6, x8	SUR/L26	1 1/16	5	2	1 1/8	1 1/8	(6) 0.162 x 3 1/2	(6) 0.148 x 1 1/2	675	865	980	1,055	580	745	845	905	
SS 2x10, x12	SUR/L210	1 1/16	8 1/8	2	1 1/8	1 1/8	(10) 0.162 x 3 1/2	(10) 0.148 x 1 1/2	1,250	1,440	1,630	1,760	1,075	1,240	1,400	1,515	
2x14	SUR/L214	1 1/16	10	2	1 1/8	1 1/8	(12) 0.162 x 3 1/2	(12) 0.148 x 1 1/2	1,890	1,730	1,955	2,110	1,625	1,490	1,680	1,815	
3x10, x12	SUR/L2.56 /9	2 1/16	8 1/16	3 1/16	1 1/8	2 1/8	(14) 0.162 x 3 1/2	(2) 0.148 x 1 1/2	210	2,015	2,280	2,465	180	1,735	1,960	2,120	
3x14	SUR/L2.56 /11	2 1/16	11 1/16	3 1/16	1 1/8	2 1/8	(16) 0.162 x 3 1/2	(2) 0.148 x 1 1/2	210	2,305	2,610	2,665	180	1,980	2,245	2,290	
(2) 2x6, x8	SUR/L26-2	3 1/8	4 1/8	2 1/8	1 1/8	2 1/8	(8) 0.162 x 3 1/2	(4) 0.162 x 2 1/2	725	1,150	1,305	1,325	625	990	1,120	1,140	
(2) 2x6, x8	HSUR/L26-2	3 1/8	4 1/8	2 1/8	1 1/4	2 1/8	(12) 0.162 x 3 1/2	(4) 0.162 x 2 1/2	725	1,790	1,795	1,795	625	1,540	1,545	1,545	
(2) 2x10, x12	SUR/L210-2	3 1/8	8 1/8	2 1/8	1 1/8	2 1/8	(14) 0.162 x 3 1/2	(6) 0.162 x 2 1/2	1,150	2,015	2,280	2,345	990	1,735	1,960	2,015	
(2) 2x10, x12	HSUR/L210-2	3 1/8	8 1/8	2 1/8	1 1/4	2 1/8	(20) 0.162 x 3 1/2	(6) 0.162 x 2 1/2	1,150	2,980	3,360	3,410	990	2,565	2,890	2,935	
(2) 2x14	HSUR/L214-2	3 1/8	12 1/8	2 1/8	1 1/4	2 1/8	(26) 0.162 x 3 1/2	(8) 0.162 x 2 1/2	1,490	3,875	4,370	4,680	1,280	3,335	3,760	4,025	
4x6, x8	SUR/L46	3 1/16	4 3/4	2 1/8	1	2 1/8	(8) 0.162 x 3 1/2	(4) 0.162 x 3 1/2	730	1,150	1,265	1,265	630	990	1,090	1,090	
4x6, x8	HSUR/L46	3 1/16	4 3/4	2 1/8	1	2 1/8	(12) 0.162 x 3 1/2	(4) 0.162 x 3 1/2	725	1,790	1,795	1,795	625	1,540	1,545	1,545	
4x10, x12	SUR/L410	3 1/16	8 1/2	2 1/8	1	2 1/8	(14) 0.162 x 3 1/2	(6) 0.162 x 3 1/2	1,140	2,015	2,245	2,245	980	1,735	1,930	1,930	
4x10, x12	HSUR/L410	3 1/16	8 1/2	2 1/8	1	2 1/8	(20) 0.162 x 3 1/2	(6) 0.162 x 3 1/2	1,150	2,980	3,360	3,410	990	2,565	2,890	2,935	
4x14	SUR/L414	3 1/16	12 1/2	2 1/8	1	2 1/8	(18) 0.162 x 3 1/2	(8) 0.162 x 3 1/2	1,490	2,400	2,400	2,400	1,280	2,065	2,065	2,065	
4x14	HSUR/L414	3 1/16	12 1/2	2 1/8	1	2 1/8	(26) 0.162 x 3 1/2	(8) 0.162 x 3 1/2	1,490	3,875	4,370	4,680	1,280	3,335	3,760	4,025	

1. Uplift loads have been increased for earthquake or wind loading with no further increase allowed. Reduce where other loads govern.
2. Roof loads are 125% of floor loads unless limited by other criteria. Floor loads may be adjusted for load durations according to the code provided they do not exceed those in the roof column.
3. Truss chord cross-grain tension may limit allowable loads in accordance with ANSI/TPI 1-2014. Simpson Strong-Tie® Connector Selector® software includes the evaluation of cross-grain tension in its hanger allowable loads. For additional information, contact Simpson Strong-Tie.
4. **Fasteners:** Nail dimensions in the table are listed diameter by length. See pp. 21–22 for fastener information.