

SITE UTILITIES & ILLUMINATION PLAN
SCALE: 1" = 10'

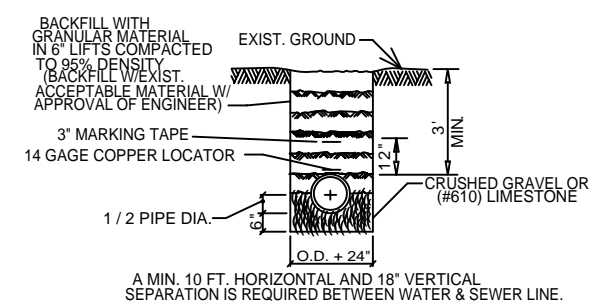

LEGEND

- - - - - PROPERTY LINE
- - - - - BUILDING SETBACK
- - - - - LANDSCAPING SETBACK, MINIMUM AND BUFFER ZONE LIMITS AT REAR
- _____ NEW BUILDING OUTLINE
- W — NEW WATER LINE
- - - - - S - - - - - NEW SEWER LINE
- - - - - E - - - - - NEW POWER LINE
- - - - - SILT FENCING DETAIL
- - - - - NEW DRAIN LINE



PIPE BEDDING DETAIL FOR SEWER & WATER LINE
N.T.S.

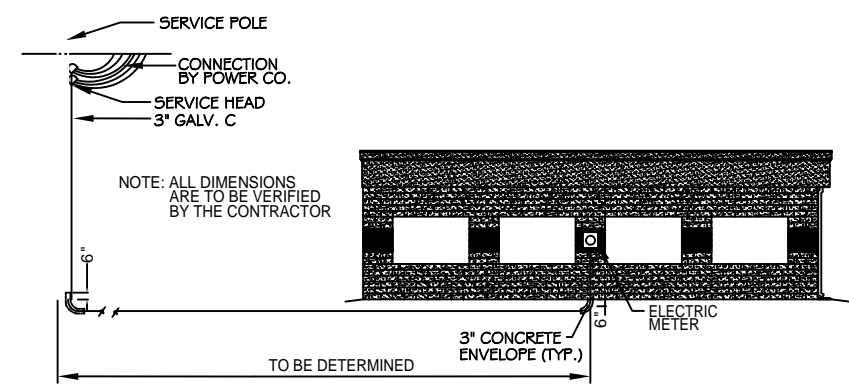

ELECTRICAL SERVICE DETAIL
N.T.S.

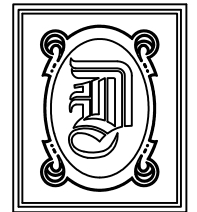

DAMMON ENGINEERING, INC.

CHIEF ENGINEER
EMMETT DAMMON, P.E.

CHIEF ARCHITECT
ROBERT WILTSE

1095 FLORIDA AVENUE
SLIDELL, LA. 70458
OFFICE: 985-649-5832
FAX: 985-641-5950

WEBSITE:
WWW.DAMMONENGINEERING.COM

EMAIL:
DAMMONENG@BELLSOUTH.NET

- ARCHITECTURE
- ENGINEERING
- STUDIES
- PLANNING
- INVESTIGATION
- EXPERT WITNESS

CECIL BOYD
CAR WASH
4TH ST & EAST HALL
LOT 1, 3, & 5

SITE
UTILITIES &
ILLUMINATION
PLAN

REV:

SCALE: AS NOTED

JOB#: 2074

DATE: 08-06-10

SHEET

C-5

OF