

DAMMON ENGINEERING, INC.

CHIEF ENGINEER
EMMETT DAMMON, P.E.

CHIEF ARCHITECT
ROBERT WILTSE

554 OLD SPANISH TRAIL
SLIDELL, LA. 70458
OFFICE: 985-649-5832
FAX: 985-641-5950

WEBSITE:
WWW.DAMMONENGINEERING.COM

EMAIL:
DAMMONENG@BELLSOUTH.NET

ARCHITECTURE

ENGINEERING

STUDIES

PLANNING

INVESTIGATION

EXPERT WITNESS

BROCK BEAUTY INC.

K.B. KAUFMANN
OAK HARBOR BLVD.
LOT 3
SLIDELL, LA
70458

SITE AND UTILITIES PLAN

REV:

SCALE: AS NOTED

JOB#: 2125

DATE: 12-21-11

SHEET 3

C-2

OF 18

LANDSCAPE LEGEND

- SOUTHERN LIVE OAK
PER OAK HARBOR ARCHITECTURAL REVIEW COMMITTEE (ARC), NEW SOUTHERN LIVE OAKS SHALL HAVE A MIN. CALIPER OF FOUR INCHES (4"), HEIGHT OF 12 FEET (12'), AND A FIVE FOOT (5') CANOPY AT THE TIME OF PLANTING. PLANT ONE TREE AT 100' ON CENTER. SETBACK 15' INTO PLANTING BUFFERS FRONTING OAK HARBOR BLVD. AND MARINA DR.
- SWAMP RED MAPLE
PER OAK HARBOR ARCHITECTURAL REVIEW COMMITTEE (ARC), NEW SWAMP RED MAPLES SHALL HAVE A MIN. CALIPER OF TWO AND A HALF INCHES (2.5"), AND A HEIGHT OF 12 FEET (12') AT THE TIME OF PLANTING. PLANT ONE TREE PER 25 FEET (25') OF STREET FRONTAGE AND MAY BE PLANTED IN GROUPS OR CLUSTERS.
- SHRUB (INDIAN HAWTHORNE)
- GROUND COVER (ASIAN JASMINE OR MULCH)
- GRASS SOD

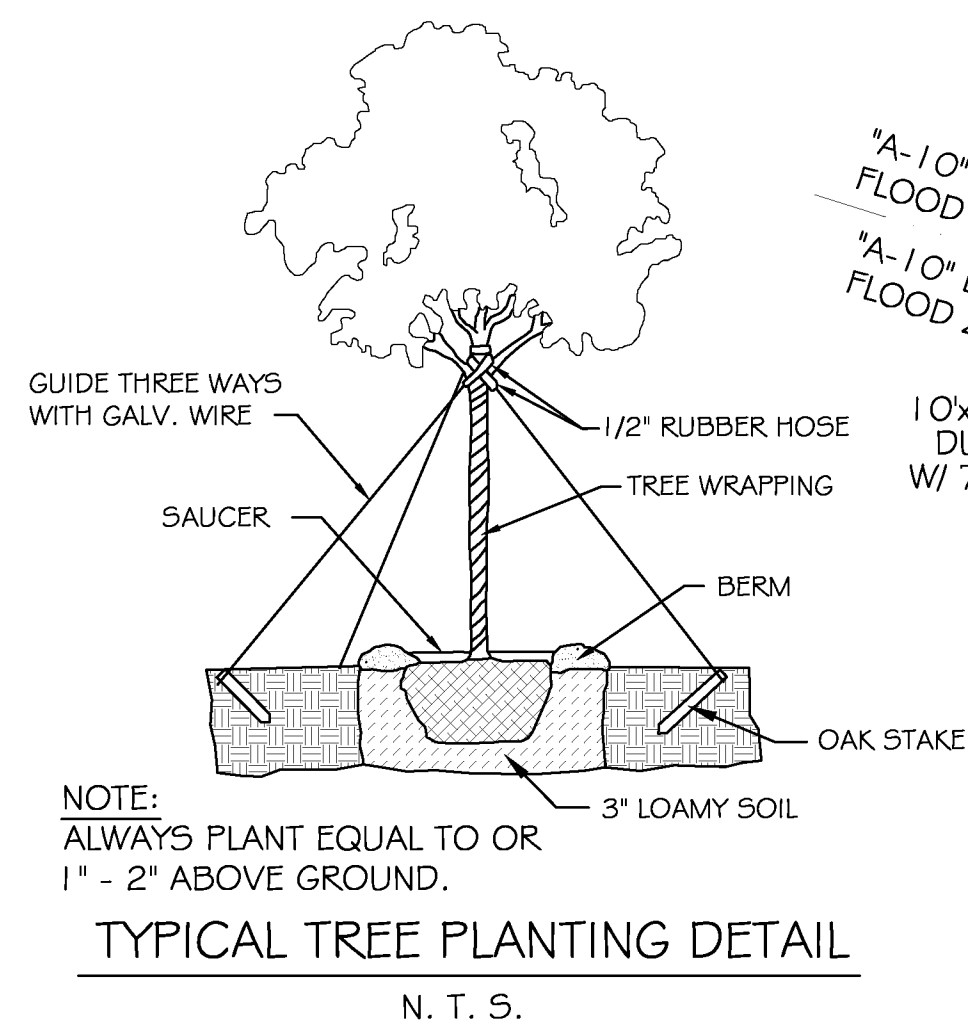

SITE LIGHTING

EXTERIOR LIGHTING SHALL BE SHADED OR INWARDLY DIRECTED IN SUCH A MANNER SO THAT NO DIRECT LIGHTING OR GLARE BE CAST BEYOND THE PROPERTY LINE. THE INTENSITY OF SUCH LIGHTING SHALL NOT EXCEED ONE FOOT CANDLE AS MEASURED AT THE ADJUTING PROPERTY LINE.

PARKING REQUIREMENTS

GROSS BUILDING SQUARE FEET 6,000
REQUIRED: 3 SPACES PER 1,000 SQ.FT.
(6,000/1,000)X3 = 18 SPACES

PROVIDED: 18 SPACES

SITE LEGEND

- PROPERTY LINE
- SETBACK LINE
- UTILITY EASEMENT LINE
- 6' OPAQUE BUFFER FENCE
- HANDICAP PARKING
- HANDICAP PARKING SIGN
- TRAFFIC ARROW

ZONED
P.U.D. C-2
HIGHWAY COMMERCIAL

LEGAL DESCRIPTION

LOT 3
OAK HARBOR COMMERCIAL PHASE II
ST. TAMMANY PARISH, LA.

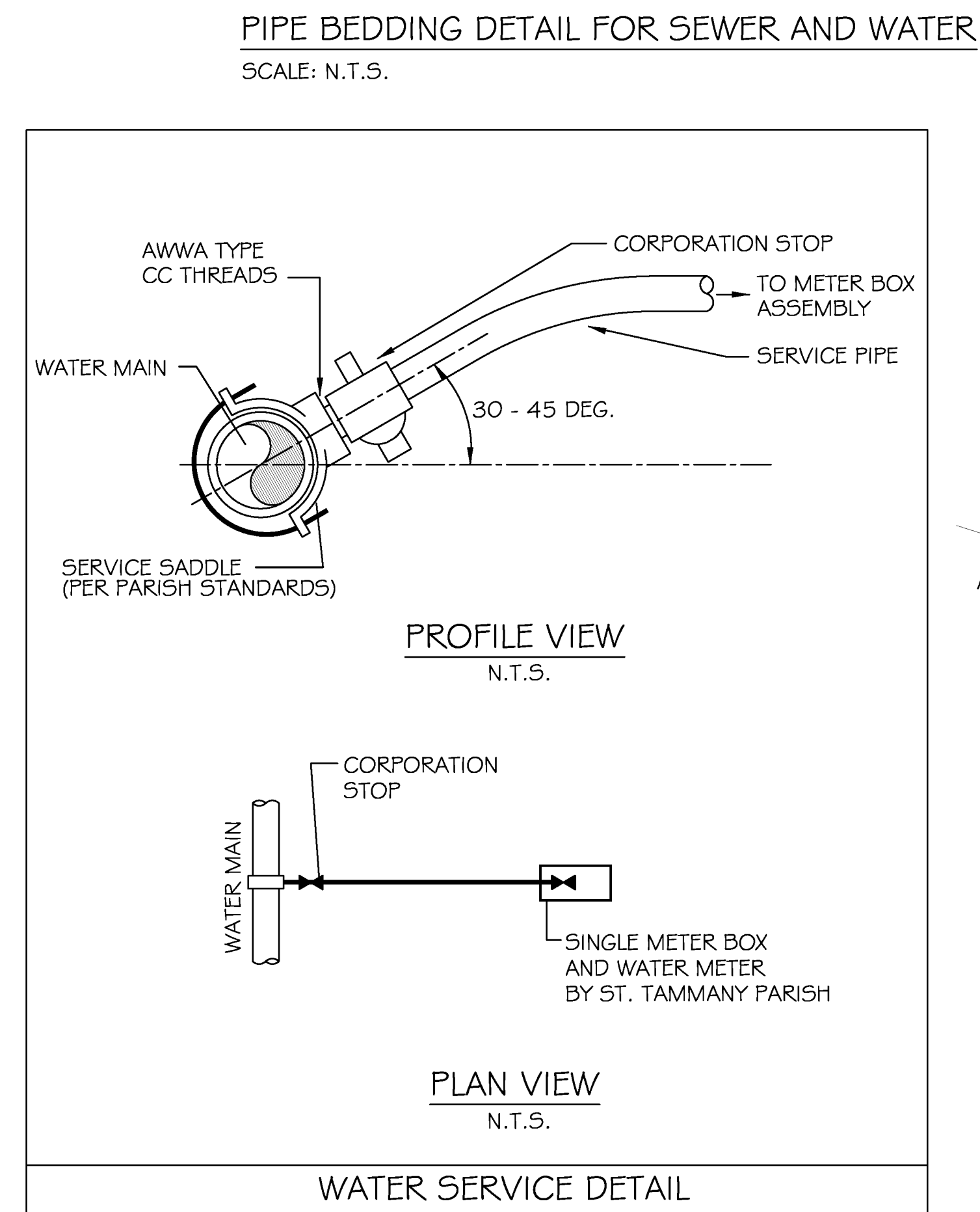
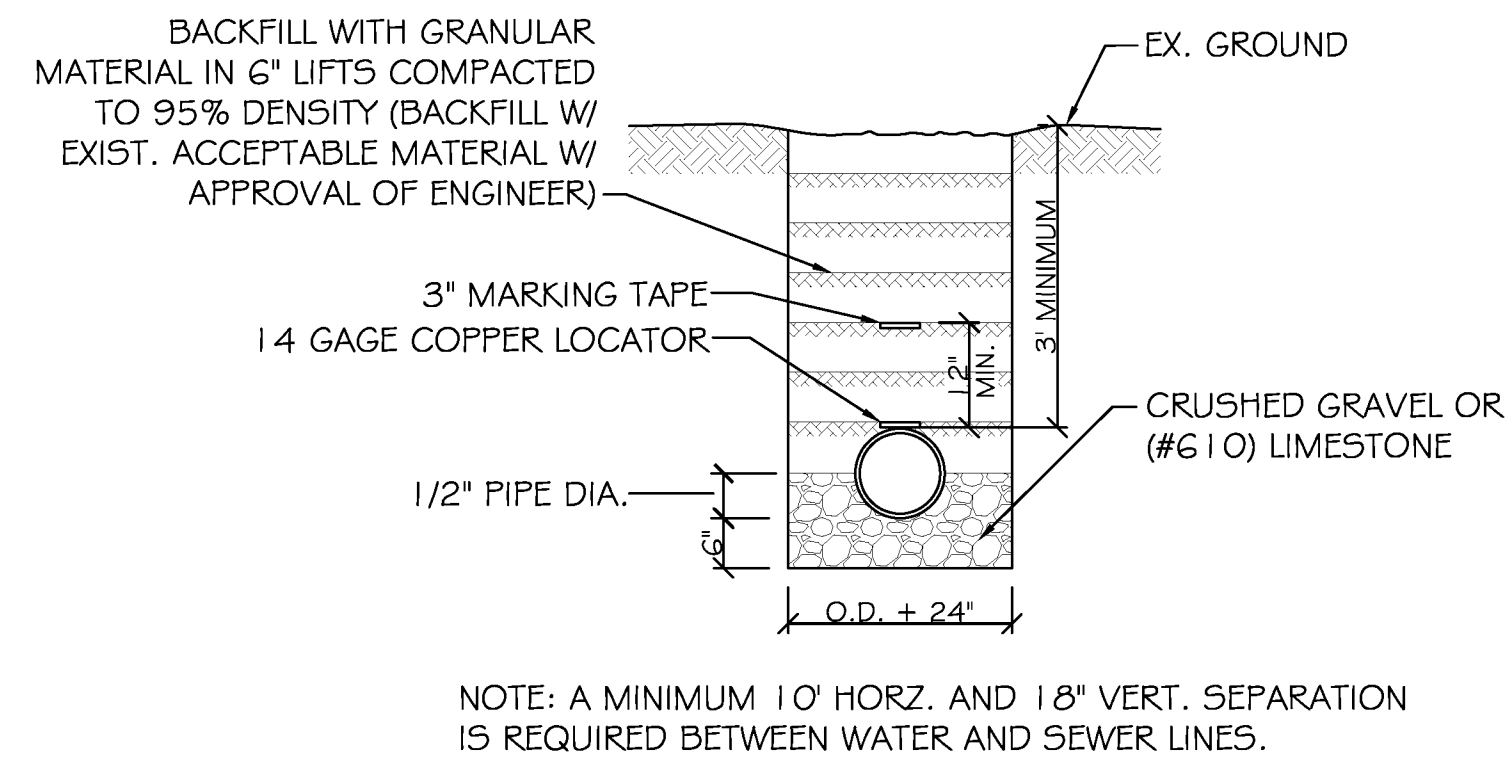

BUFFER LANDSCAPING
TOTAL OAK HARBOR BLVD. LANDSCAPE BUFFER AREA = 2000 SQ.FT.
20% OF TOTAL AREA MUST BE LANDSCAPED WITH GROUND COVER AND SHRUBS
20% = 400 SQ.FT.
540 SQ.FT. PROVIDED

OAK HARBOR ARCHITECTURAL REVIEW COMMITTEE (ARC) LANDSCAPE REQUIREMENTS:

LANDSCAPE BUFFER ALONG OAK HARBOR BOULEVARD, AND MARINA DRIVE: PROVIDE A 20 FEET DEEP LANDSCAPE BUFFER WITHIN THE PROPERTY LINE ADJUTING THE RIGHT OF WAY. THE BUFFER SHALL INCLUDE MOUNDS TO A MAXIMUM HEIGHT OF 3' ABOVE THE ADJACENT VEHICULAR USE AREA FORMING AN UNDULATING LANDSCAPED BERM. THE BUFFER SHALL CONTAIN TREES, SHRUBS, AND OTHER LANDSCAPE ELEMENTS. AT MINIMUM, 20% OF THE REQUIRED LANDSCAPE BUFFER SHALL BE PLANTED WITH SHRUBS AND GROUND COVER.

ALL SITES ON OAK HARBOR BLVD. SHALL PROVIDE ONE SOUTHERN LIVE OAK EVERY AT 100' ON CENTER, 15' INTO THE BUFFER AREA. TREES IN ADDITION TO THE LIVE OAKS SHALL BE PLANTED AT A RATE OF ONE TREE PER 25' OF STREET FRONTAGE WHICH MAY BE PLANTED IN GROUPS OR CLUSTERS.

REFUSE AND DUMPSTER STORAGE AREA: DUMPSTER AREA SHALL BE ENCLOSED BY A MINIMUM 6' SOLID SCREEN WITH OPERABLE SWINGING OR SLIDING GATES. THE EXTERIOR SCREENING SHALL MATCH IN COLOR WITH THE EXTERIOR OF THE IMPROVEMENTS.

INTERIOR LANDSCAPING OF VEHICULAR USE AREA: LANDSCAPED AREAS SHALL BE PROVIDED WHEN THE VEHICULAR USE AREA EXCEEDS 5000 SQ.FT.
a) THE TOTAL OF ALL INTERIOR LANDSCAPED AREAS SHALL OCCUPY AT LEAST 8% OF VEHICULAR USE AREA.
b) EACH INTERIOR LANDSCAPE AREA SHALL BE AT LEAST 100 SQ.FT.
c) THE INTERIOR LANDSCAPE AREA SHALL BE RAISED AND HAVE A 6" CONCRETE CURB.
d) EACH INTERIOR LANDSCAPED ISLAND SHALL HAVE A TREE.
e) EACH INTERIOR LANDSCAPED AREA SHALL BE, AT A MINIMUM, SODDED.

PERIMETER LANDSCAPE STRIP: A PERIMETER LANDSCAPE STRIP SHALL HAVE A MINIMUM WIDTH OF 5' ALONG THE OUTER EDGE OF A VEHICULAR USE AREA EXCEPT WHERE A LANDSCAPE BUFFER IS REQUIRED. TREES SHALL BE PLANTED AT A RATE OF 1 TREE PER 250 SQ.FT. OF SIDE YARD LANDSCAPE AREA.

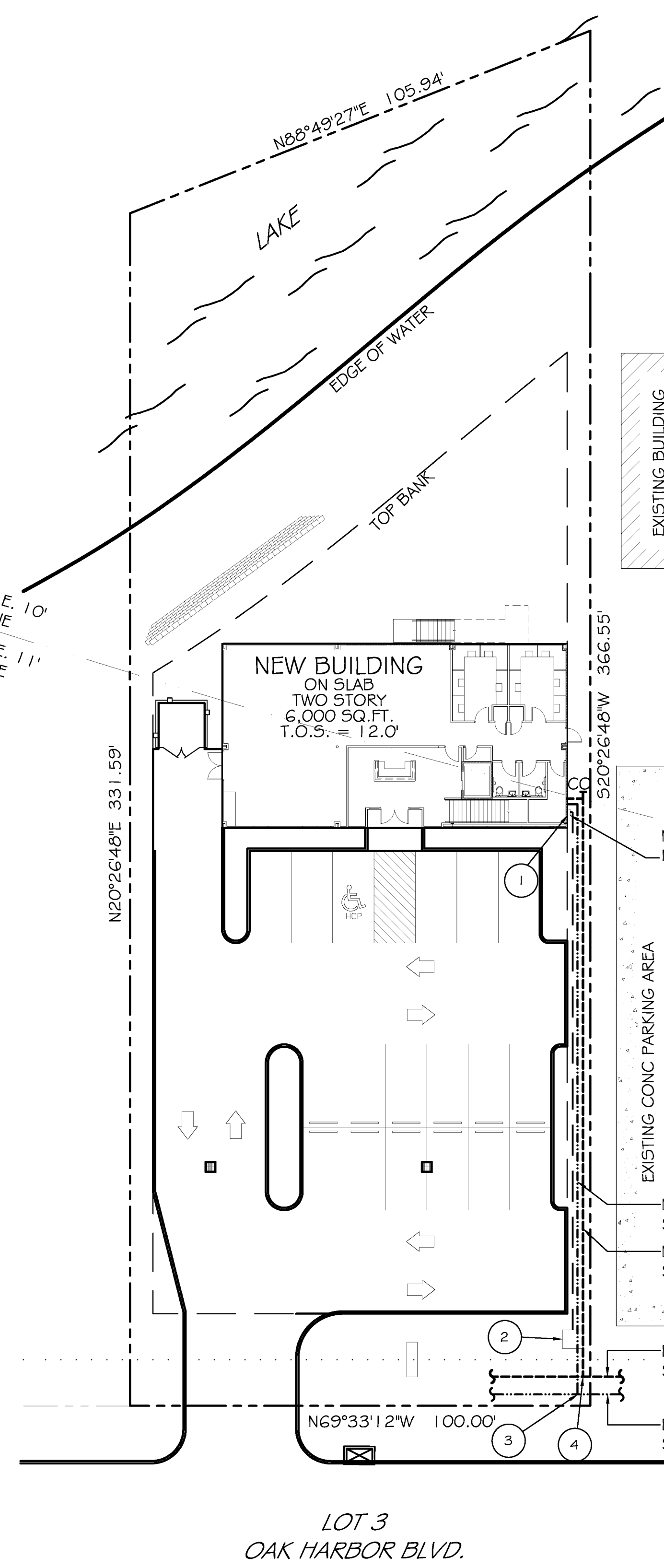
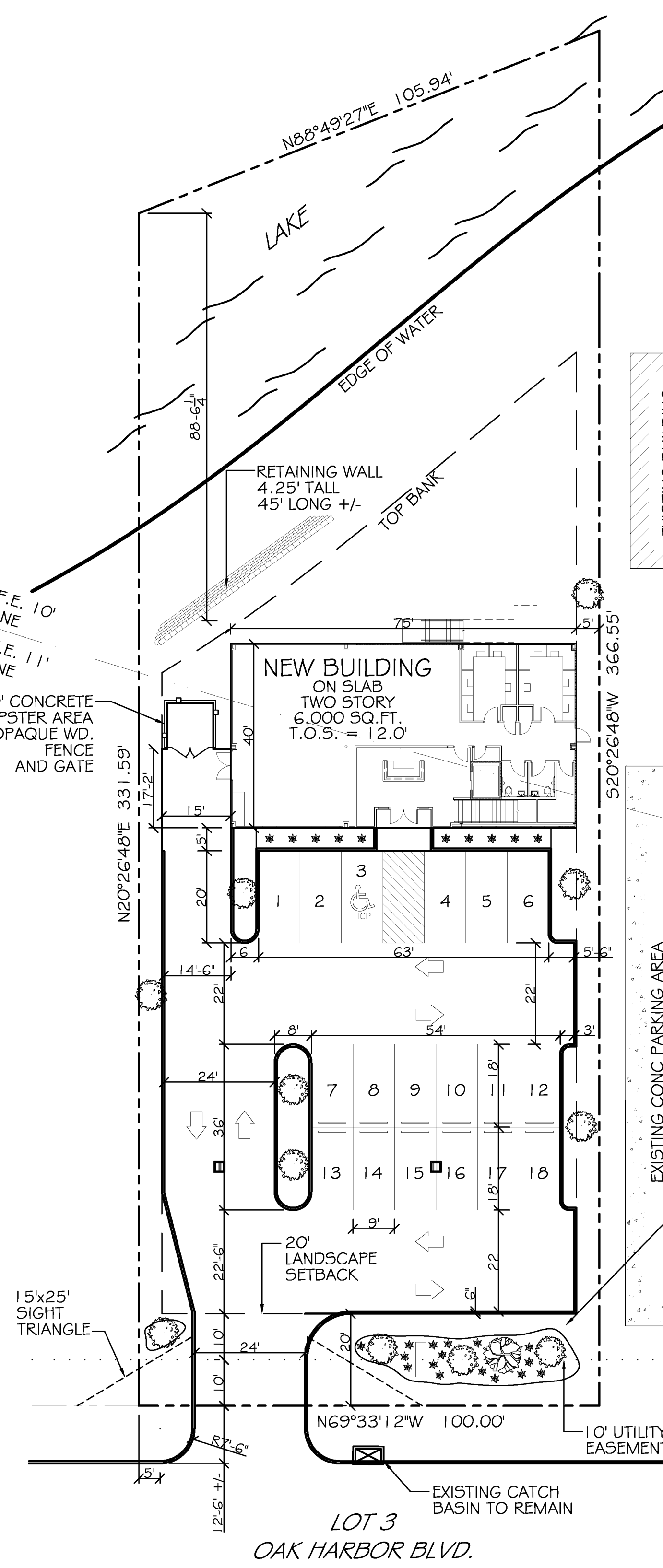

- UTILITY LEGEND**
- PROPERTY LINE
 - SETBACK LINE
 - UTIL. EASEMENT LINE
 - SEWER LINE
 - WATER LINE
 - U.G. ELEC. CONDUIT

- UTILITY NOTES:**
1. SCH. 80 PVC CONDUIT WHERE PIPE IS EXPOSED OUTSIDE OF BUILDING WALL. TRANSITION BACK TO SCH.40 PVC @ 90° PVC ELBOW BELOW GRADE. ALL 90° FITTINGS TO BE 36" LONG SWEEP TYPE.
 2. 120/208V 3Ø 225A SERVICE FROM UTIL. CO., FEEDER BY UTIL. CO. FIELD LOCATE TRANSFORMER AND COORDINATE WITH ELEC. COMPANY REGARDING ELECTRICAL SERVICE CONNECTION.
 3. TIE NEW WATER SERVICE INTO EXISTING WATER MAIN ON OAK HARBOR BLVD., FIELD VERIFY LOCATION. SEE DETAIL THIS SHEET. RELOCATE EXISTING WATER METER AS NEEDED.
 4. TIE NEW SEWER SERVICE INTO EXISTING SEWER MAIN ON OAK HARBOR BLVD., FIELD VERIFY LOCATION.