

18027

RESIDENCE AT LOT 17 BETH DRIVE

LOTS 17 BETH DRIVE, SLIDELL, LA, 70458

PROJECT DATA:

PROPERTY ZONE: A-4
 CONSTRUCTION TYPE: TYPE VB UNPROTECTED
 OCCUPANCY TYPE: IRC 2015 - SINGLE FAMILY RESIDENCE
 BUILDING AREA: 1,330 TOTAL SF

GENERAL NOTES:

- WORK SHALL BE IN COMPLIANCE WITH THE 2015 INTERNATIONAL RESIDENTIAL CODE - 130 MPH BASIC WIND SPEED.
- CONTRACTOR SHALL VISIT SITE AND VERIFY CONDITIONS PRIOR TO SUBMITTING BID. CONTRACTOR SHALL ADVISE ARCHITECT IF EXISTING CONDITIONS ARE IN CONFLICT WITH THESE DOCUMENTS.
- GENERAL CONTRACTOR TO PROVIDE 1 YEAR WARRANTY ON ALL WORK BEGINNING ON THE DATE OF SUBSTANTIAL COMPLETION.
- MECHANICAL AND ELECTRICAL SYSTEMS SHALL BE CONSTRUCTED IN ACCORDANCE WITH IMC 2015, IEC 2015 & IRC 2015.
- PLUMBING WORK SHALL BE IN ACCORDANCE WITH IPC 2015 AND LA. STATE PLUMBING CODE 2015.
- ROOFING FASTENERS AND FLASHING TO BE INSTALLED IN ACCORDANCE WITH MANUFACTURER'S RECOMMENDATIONS. FASCIA, FLASHING AND TRIM MATERIALS TO MATCH GAUGE AND FINISH OF ROOFING.
- CONTRACTOR TO VERIFY SITE LOCATIONS FOR UTILITY TIE-INS AND COORDINATE WORK IN THESE AREAS WITH UTILITY COMPANIES. CONTRACTOR TO OBTAIN AND PAY FOR ASSOCIATED PERMITS AND IMPACT FEES.
- CONTRACTOR TO DISPOSE OF ALL CONSTRUCTION DEBRIS IN ACCORDANCE WITH APPLICABLE LOCAL CODES AND LA DEQ.
- ALL PLYWOOD MATERIAL MUST BE IN ACCORDANCE WITH APA STANDARDS. SUBROOFING AND WALL SHEATHING MATERIAL TO BE 1/2" OSB.
- EXTERIOR WALLS TO BE CLAD IN PERFORATED BUILDING WRAP WITH TAPED JOINTS AS PER MFR. RECOMMENDATIONS. ROOF TO MATCH EXISTING STANDING SEAM METAL ROOF.
- GYP. BD. WALLS AND CLGS. TO BE LIGHT ORANGE PEEL FINISH. ALL INTERIOR PAINTED SURFACES SHALL RECEIVE ONE COAT PRIMER AND TWO FINISH COATS IN ACCORDANCE WITH PAINT MFR. RECOMMENDATIONS.
- ALL ELECTRICAL DEVICES, FIXTURES, PLUMBING FIXTURES, KITCHEN CABINETS AND APPLIANCES WILL BE PROVIDED TO CONTRACTOR FOR INSTALLATION.
- ALL EXPOSED PIPING IN ATTIC SHALL BE WRAPPED WITH 3/4" POLYSTYRENE INSULATION.
- BATT INSULATION IN ALL EXTERIOR WALLS AND BETWEEN RAFTERS OF CEILING STRUCTURE TO BE FULL THICKNESS W/ SOLAR REFLECTIVE SCRIM FACE.
- INSULATE BATHROOM WALLS WITH 3 1/2" UNFACED SOUND BATT INSULATION FROM FLOOR TO CEILING.
- ARROW INDICATES SURFACE DRAINAGE AND SWALES.
- ARROW INDICATES PAVED AREA DRAINAGE DIRECTION.
- PROVIDE FENCING AROUND TREES TO REMAIN ALONG THEIR DRIP LINES AND MAINTAIN THAT PROTECTION THROUGHOUT CONSTRUCTION.

DRAWING INDEX:

COVER AND VICINITY MAP

| | |
|------|---|
| A1.0 | SITE PLAN |
| A2.0 | FLOOR PLAN AND UTILITY PLAN |
| A3.0 | SCHEDULES AND DETAILS |
| A4.0 | BUILDING ELEVATIONS |
| A5.0 | BUILDING SECTIONS, WIND STRAPPING DETAILS |
| S1.0 | FOUNDATION PLAN AND DETAILS |
| S2.0 | FRAMING PLANS |
| MEP | MECHANICAL, ELECTRICAL, PLUMBING DETAILS |

STRUCTURAL LOADING:

2015 IBC, FIGURE 1609
 ULTIMATE DESIGN WIND SPEED, 128 MPH
 NOMINAL DESIGN WIND SPEED, 99 MPH

(IBC 1609.2) - WIND BORNE DEBRIS REGION. PORTIONS FOR HURRICANE-PRONE REGIONS THAT ARE WITHIN 1 MILE (1.61 KM) OF THE COASTAL MEAN HIGH WATER LINE WHERE THE BASIC WIND SPEED IS 130 MPH (48 M/S) OR GREATER +/- OR HAWAII. (IBC 1609.3) - THE BASIC WIND SPEED, IN MPH, FOR THE DETERMINATION OF THE WIND LOADS SHALL BE DETERMINED BY FIGURE 1609. BASIC WIND SPEED FOR THE SPECIAL WIND REGIONS INDICATED, NEAR MOUNTAINOUS TERRAIN AND NEAR GORGES SHALL BE IN ACCORDANCE WITH SECTION 6.5.4 OR ASCE7.

PROJECT IS NOT IN A WIND BORNE DEBRIS REGION.

IN NON-HURRICANE-PRONE REGIONS, WHEN THE BASIC WIND SPEED IS ESTIMATED FROM REGIONAL CLIMATIC DATA, THE BASIC WIND SPEED SHALL BE NOT LESS THAN THE WIND SPEED ASSOCIATED WITH AN ANNUAL PROBABILITY OF 0.02 (50-YEAR MEAN RECURRENCE INTERVAL), AND THE ESTIMATE SHALL BE ADJUSTED FOR EQUIVALENCE TO A 3-SECOND GUST WIND SPEED AT 33 FEET (10 M) ABOVE GROUND IN EXPOSURE CATEGORY 'C'. THE DATA ANALYSIS SHALL BE PERFORMED IN ACCORDANCE WITH: SECTION 6.5.4.2 OF ASCE7.

BUILDING FRAME AND COMPONENTS DESIGNED BASED ON LOADS FROM ASCE7-05.

ENCLOSED BUILDING
 RISK CATEGORY 'II' (IBC 1604.5)
 SNOW LOAD = 0 (IBC 1608.2)
 WIND EXPOSURE 'B' (IBC 1609.4)
 WIND IMPORTANCE FACTOR = 1.0
 INTERNAL PRESSURE COEFFICIENT = 1.18
 COMPONENT, CLADDING WIND PRESSURE=35.2 PSF
 MAIN WIND RESISTING SYSTEM = POST & BEAM
 FLOOR LIVE LOADS - 40 PSF
 FLOOR DEAD LOADS - 20 PSF
 ROOF LIVE LOAD - 40 PSF
 LIMITED STORAGE ATTIC LIVE LOAD - 20 PSF

FLOOD ZONE REQUIREMENTS:
 PROJECT IS IN FLOOD ZONE 'AE' - 12.

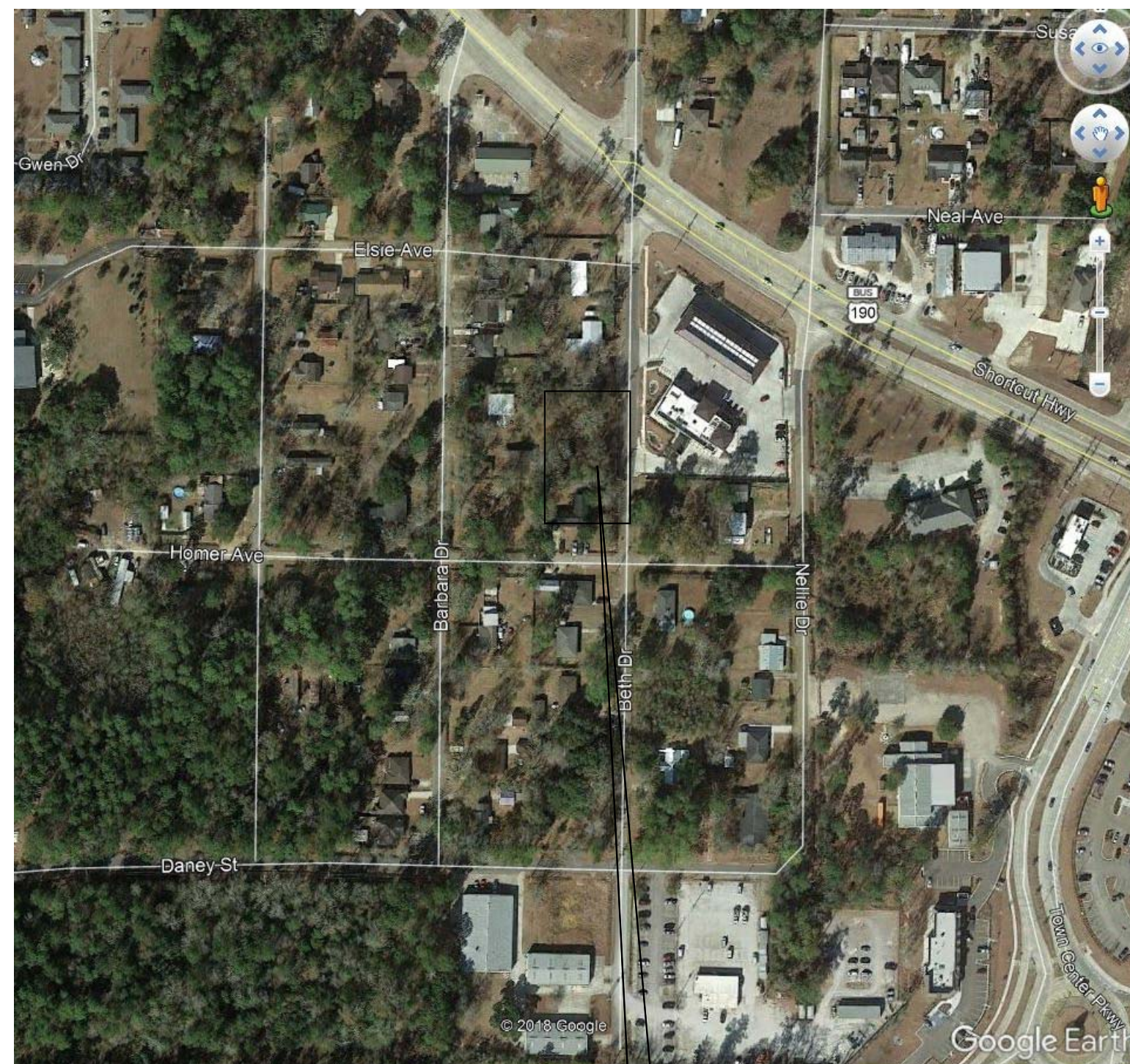

SITE
VICINITY MAP
 NO SCALE

KVS
 architecture

235 Girod Street, Mandeville, Louisiana
 985.674.3077 www.kvsarchitecture.com

1.22.19

1.22.19



THESE DRAWINGS HAVE BEEN PREPARED BY ME OR UNDER MY DIRECT SUPERVISION, AND TO MY KNOWLEDGE COMPLY WITH ALL LOCAL, STATE, AND FEDERAL REQUIREMENTS.
 K. VAUGHAN SOLLBERGER, JR., AIA, NCARB, LA# 5523

18027
 RESIDENCE AT LOT 17 BETH DRIVE
 LOTS 17 BETH DRIVE, SLIDELL, LA, 70458

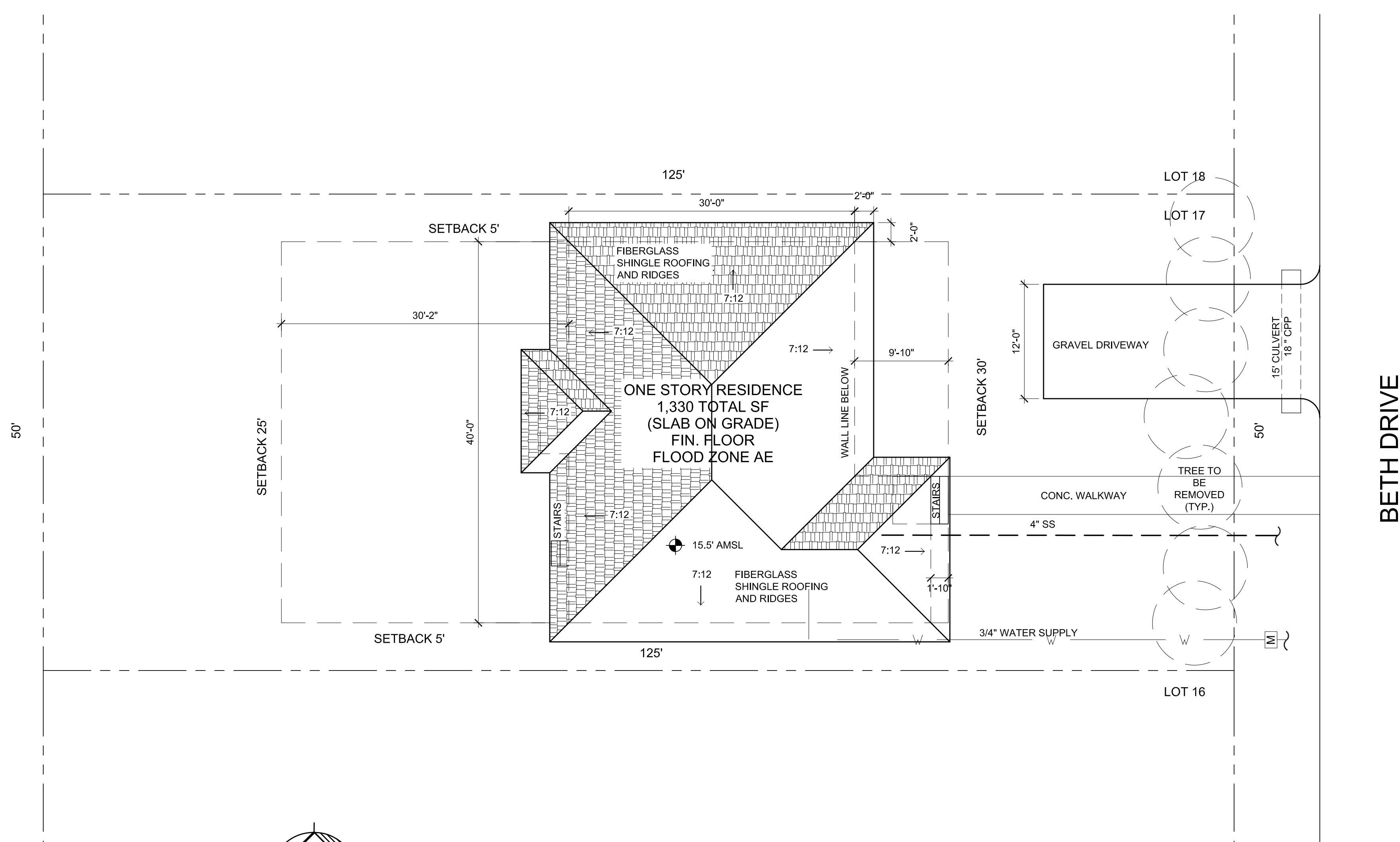

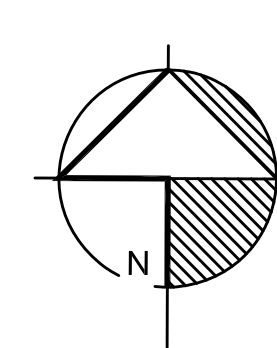
1 **SITE PLAN**
 1/8" = 1'-0"

RESIDENCE AT LOT 17 BETH DRIVE
 LOT 17 BETH DRIVE, SLIDELL, LOUISIANA



REVISIONS:

| | |
|-------------|---------|
| DATE: | 1.22.19 |
| PROJECT No: | 18027 |
| DRAWING: | |

A1.0

RESIDENCE AT LOT 17 BETH DRIVE
 LOT 17 BETH DRIVE, SLIDELL, LOUISIANA

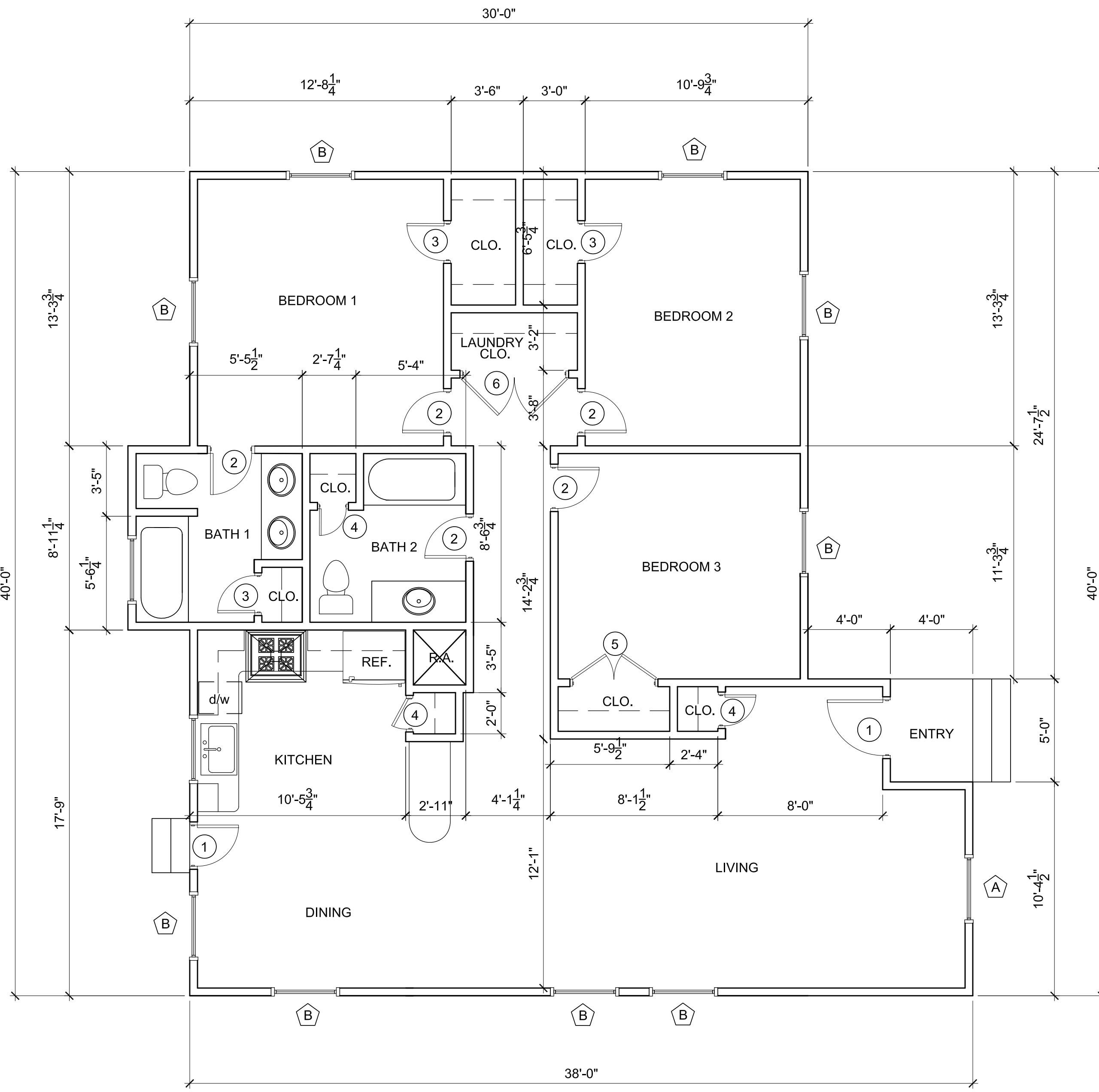

1 FLOOR PLAN
 1/4" = 1'-0"

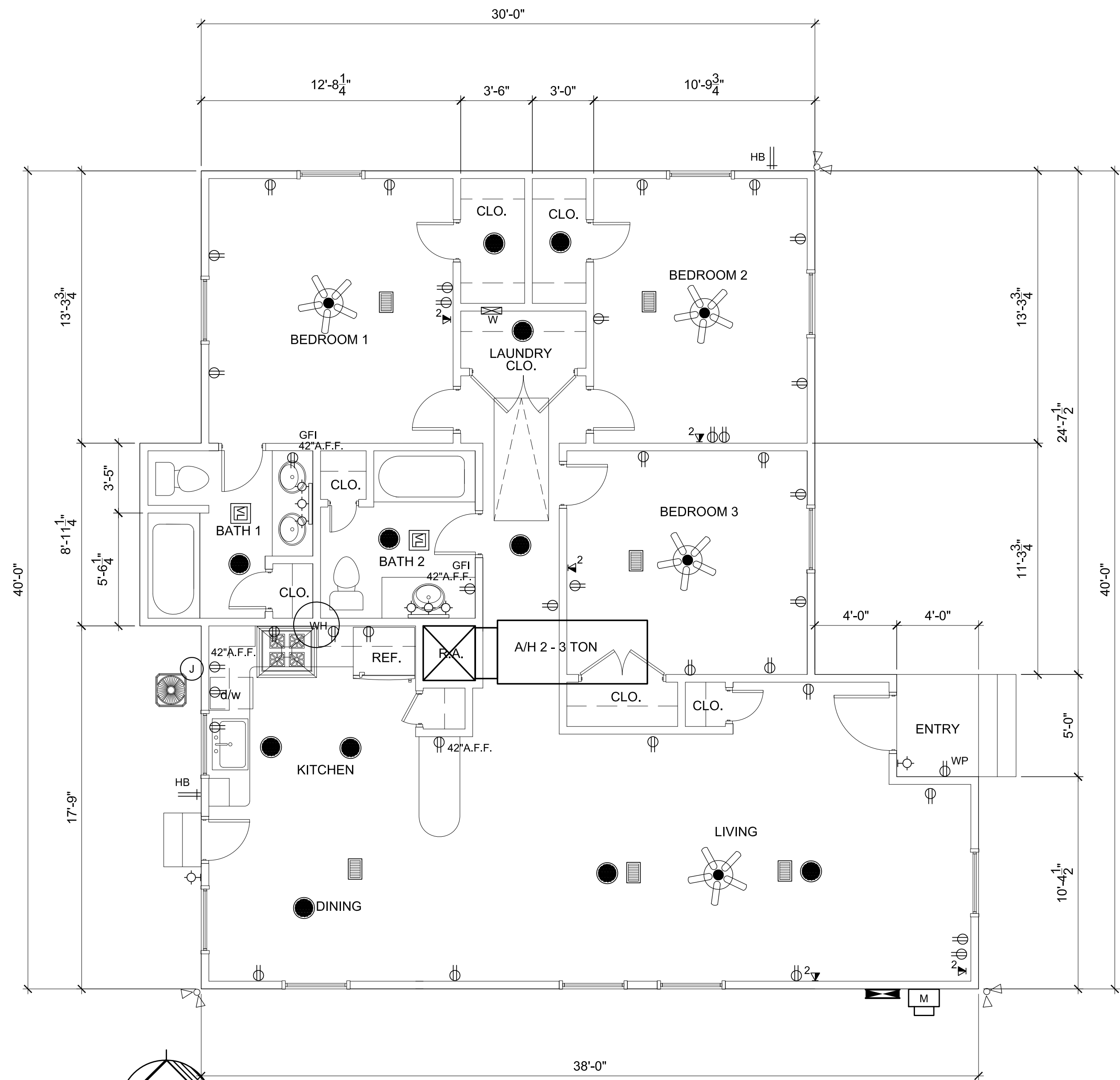

2 UTILITY PLAN
 1/4" = 1'-0"

- LEGEND OF SYMBOLS**
- CEILING FAN W/ LIGHT FIXTURE
 - 6" RECESSED CAN
 - WALL SCONCE
 - WALL MOUNT TRACK LIGHTING
 - VENT - LIGHT
 - PAR FLOODLIGHT
 - ELEC. PANEL
 - COND. UNIT
 - CEILING SUPPLY AIR
 - ELECTRICAL METER
 - ELECTRICAL JUNCTION BOX
 - 120 V WALL RECEPTACLE @ 18" A.F.F.
 - 120 V WALL RECEPTACLE (GROUND FAULT INTERRUPT)
 - 120 V WALL RECEPTACLE (WATERPROOF)
 - 120 V WALL RECEPTACLE (HEIGHT OF OUTLET OTHER THAN THE STANDARD 18" A.F.F.)
 - CAT 5 PORT AND # INDICATED
 - HOSE BIBB
 - WASHER CONNECTION
 - ELEC. WATER HEATER IN ATTIC, 65 GALLON



REVISIONS:

DATE: 1.22.19

PROJECT No: 18027

DRAWING:

A2.0



REVISIONS:

DATE: 1.22.19

PROJECT No: 18027

DRAWING:

A3.0

| ROOM FINISH SCHEDULE | | | | |
|----------------------|---------------------|---------|---------------|------------------------------|
| ROOM NAME | FLOOR | BASE | WALLS | CEILING |
| ENTRY | BROOM FIN. CONCRETE | | | VINYL ON 5/8" GYP. SHEATHING |
| LIVING | WOOD | 4" WOOD | PTD. GYP. BD. | PTD. GYP. BD. |
| DINING | WOOD | 4" WOOD | PTD. GYP. BD. | PTD. GYP. BD. |
| KITCHEN | WOOD | 4" WOOD | PTD. GYP. BD. | PTD. GYP. BD. |
| PANTRY | WOOD | 4" WOOD | PTD. GYP. BD. | PTD. GYP. BD. |
| CLOSETS | WOOD | 4" WOOD | PTD. GYP. BD. | PTD. GYP. BD. |
| BATH 1 | TILE | 4" WOOD | PTD. GYP. BD. | PTD. GYP. BD. |
| BATH 2 | TILE | 4" WOOD | PTD. GYP. BD. | PTD. GYP. BD. |
| BEDROOM 1 | WOOD | 4" WOOD | PTD. GYP. BD. | PTD. GYP. BD. |
| BEDROOM 2 | WOOD | 4" WOOD | PTD. GYP. BD. | PTD. GYP. BD. |
| BEDROOM 3 | WOOD | 4" WOOD | PTD. GYP. BD. | PTD. GYP. BD. |
| LAUNDRY CLOSET | WOOD | 4" WOOD | PTD. GYP. BD. | PTD. GYP. BD. |

NOTES:
 1. WOOD CABINETS
 2. GRANITE COUNTERTOPS

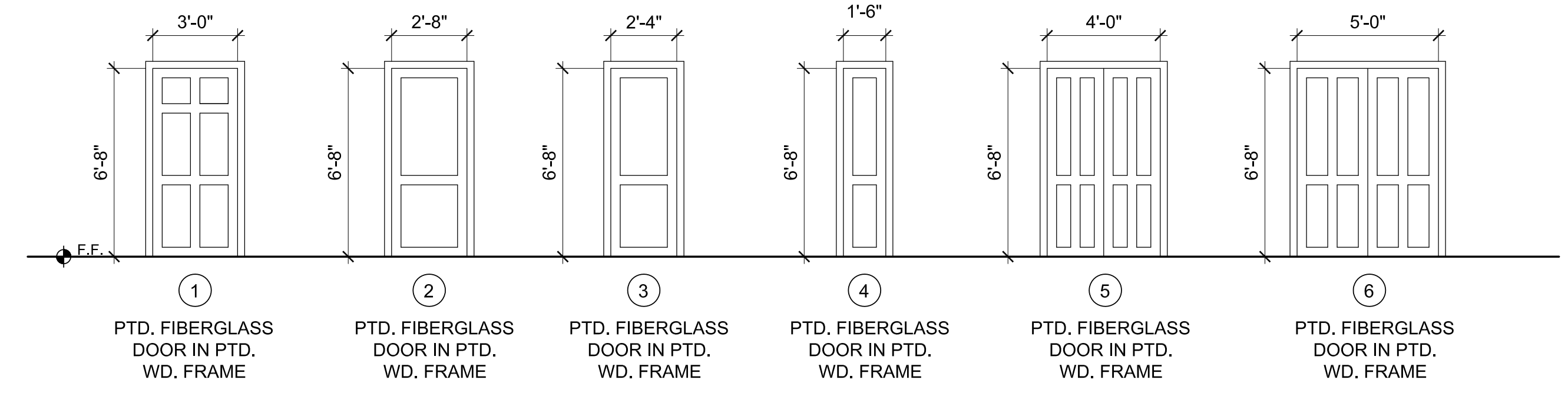

1 DOOR TYPES
 1/4" = 1'-0"

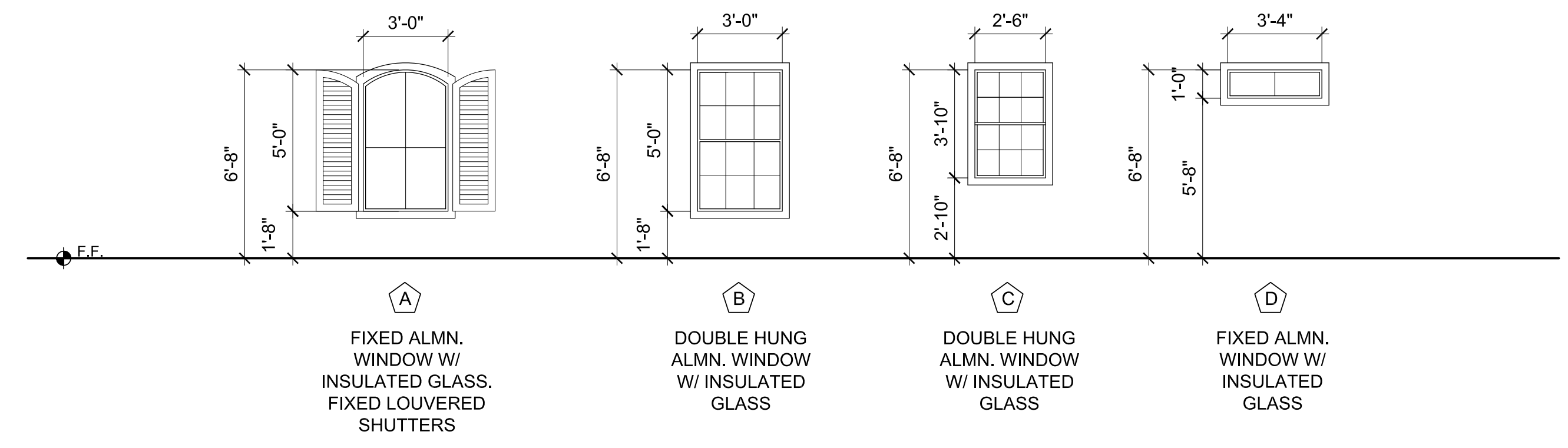

2 WINDOW TYPES
 1/4" = 1'-0"

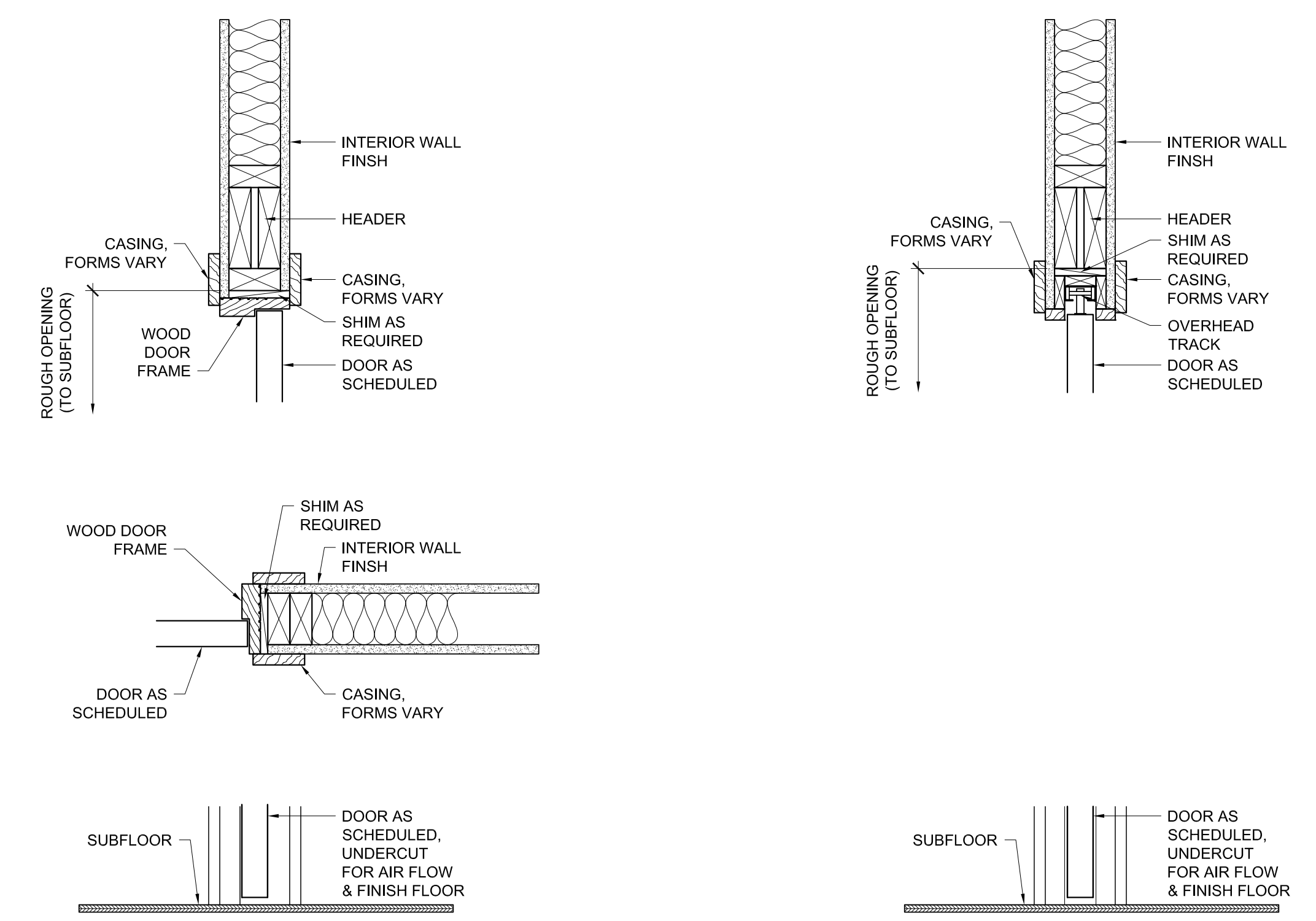

3 DOOR OPENING DETAILS
 1 1/2" = 1'-0"

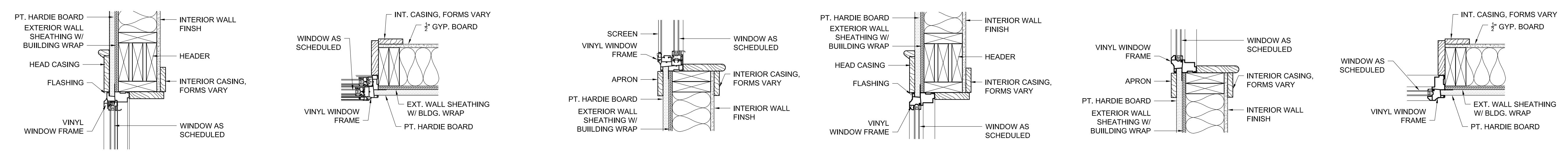

4 WINDOW OPENING DETAILS
 1 1/2" = 1'-0"

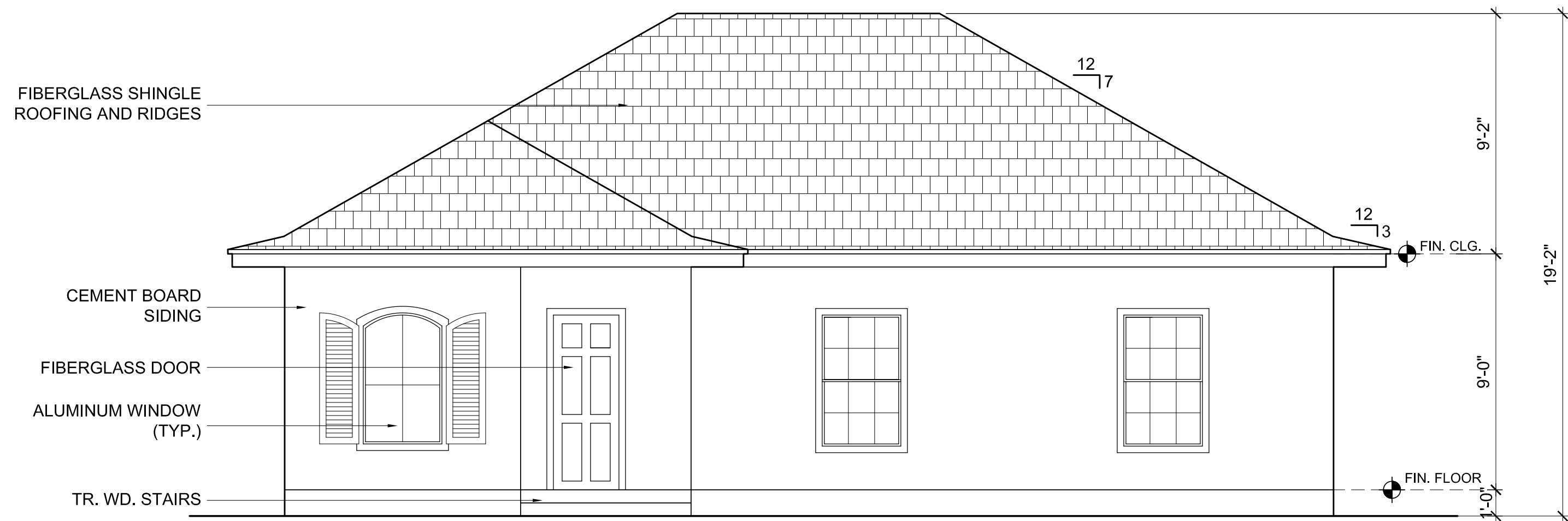

1 FRONT ELEVATION
1/4" = 1'-0"

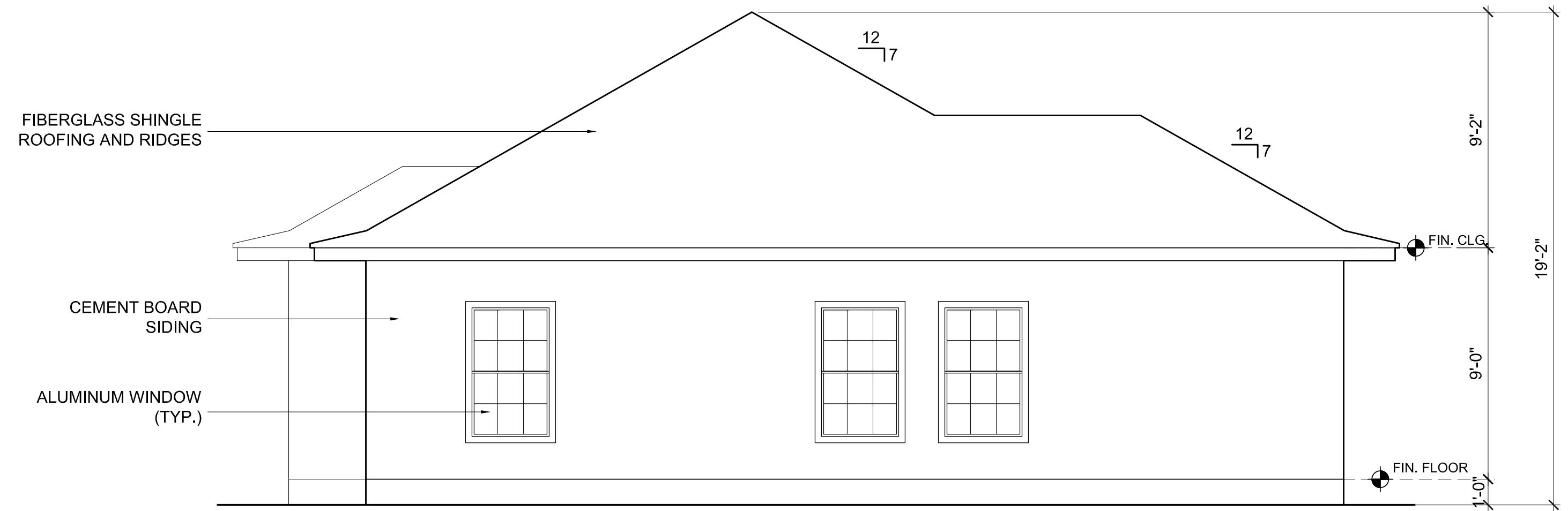

2 WEST ELEVATION
1/4" = 1'-0"

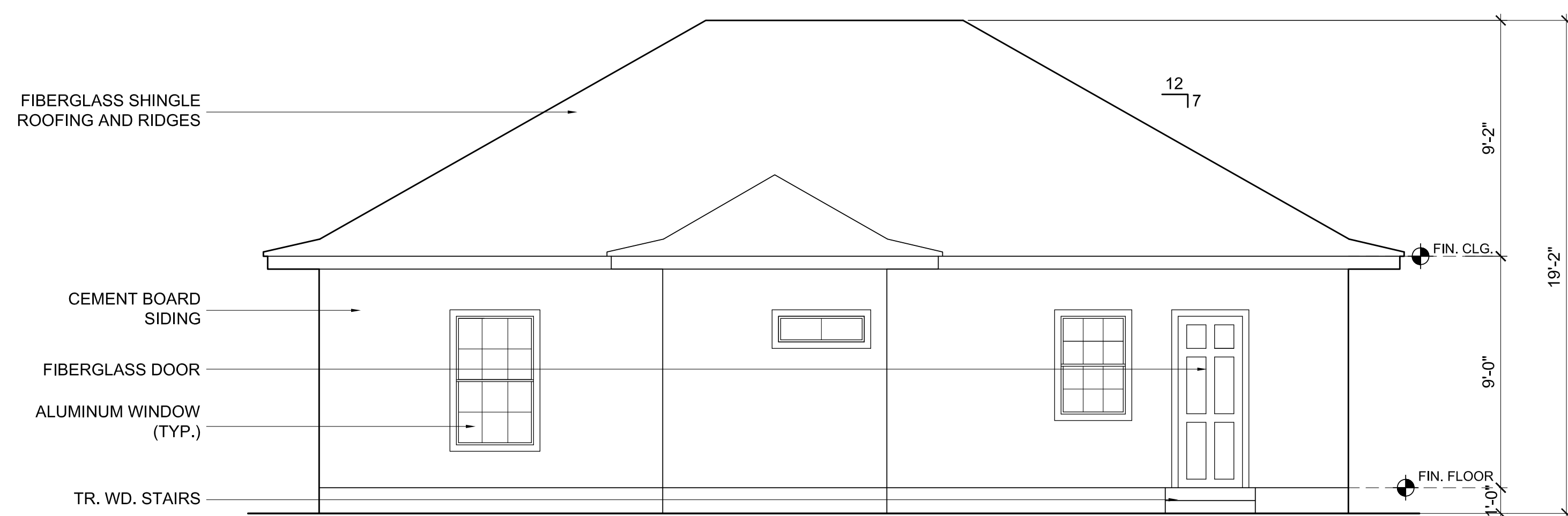

3 REAR ELEVATION
1/4" = 1'-0"

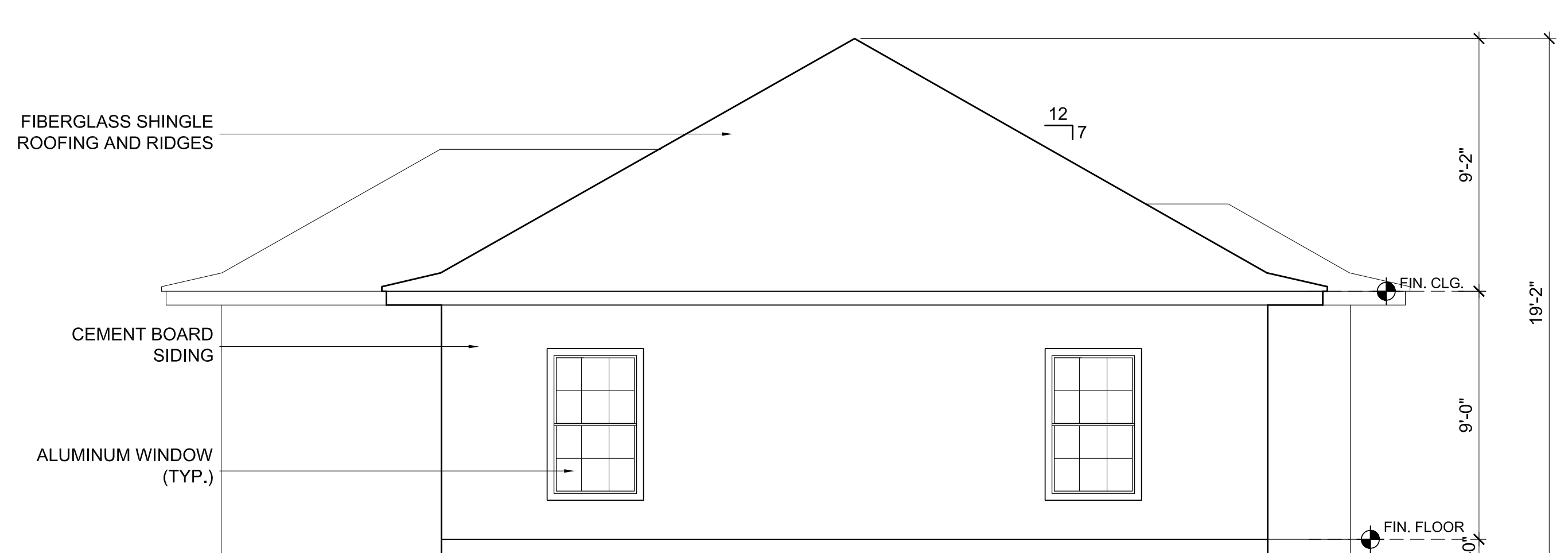

4 EAST ELEVATION
1/4" = 1'-0"



REVISIONS:

DATE: 1.22.19

PROJECT No: 18027

DRAWING:

A4.0



REVISIONS:

DATE: 1.22.19

PROJECT No: 18027

DRAWING:

A5.0

HOLDDOWN CLIPS:

HOLDDOWNS ARE REQUIRED AT THE END OF EACH SEGMENTED SHEARWALL SEGMENT OR AT THE END OF A PERFORATED SHEARWALL. WHEN FULL HEIGHT SHEARWALL SEGMENTS MEET AT A CORNER, A SINGLE HOLDDOWN SHALL BE PERMITTED TO BE USED TO RESIST THE OVERTURNING FORCES IN BOTH DIRECTIONS WHEN THE CORNER FRAMING IN THE ADJOINING WALLS IS FASTENED TOGETHER TO TRANSFER THE UPLIFT LOAD.

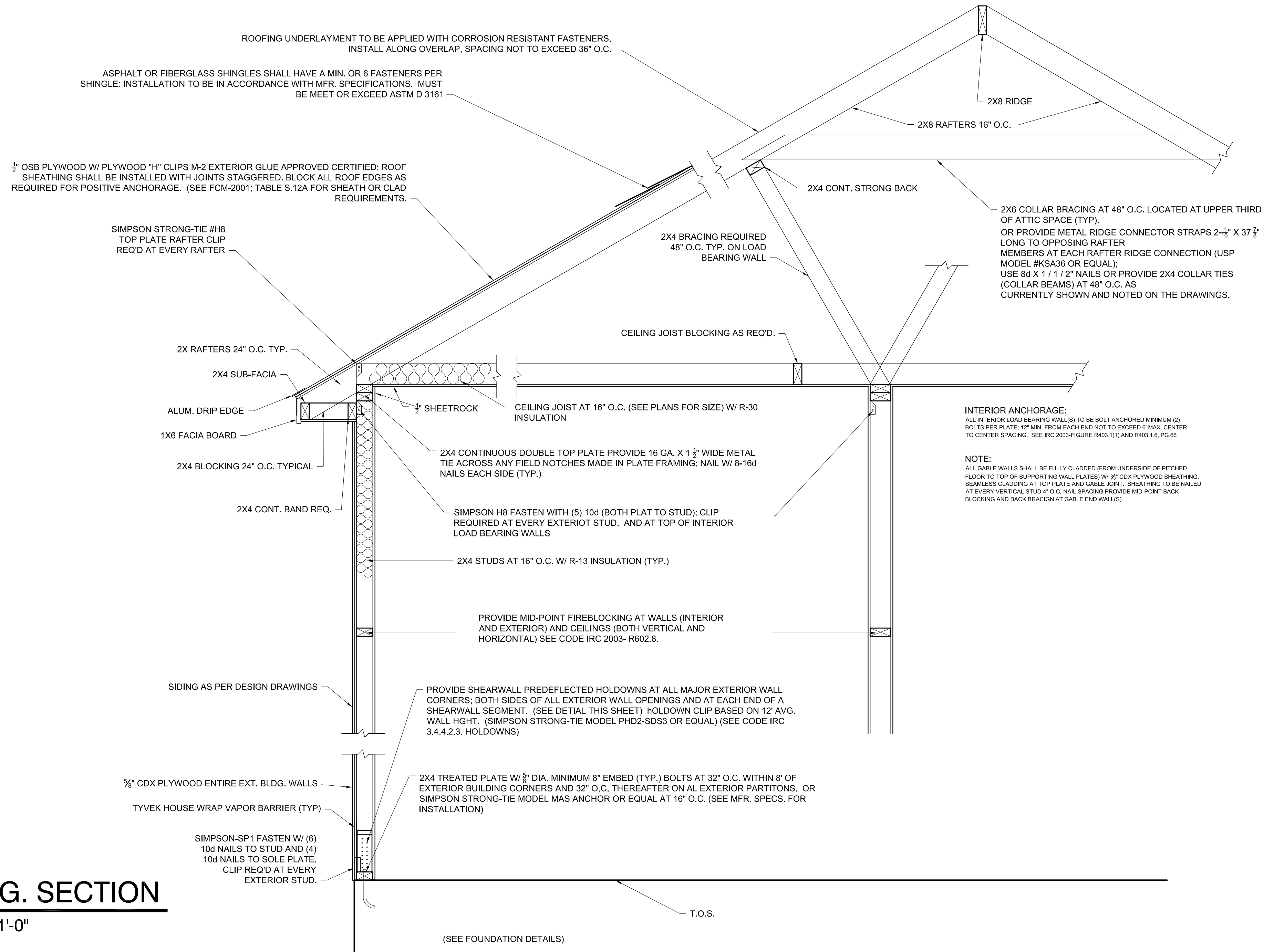
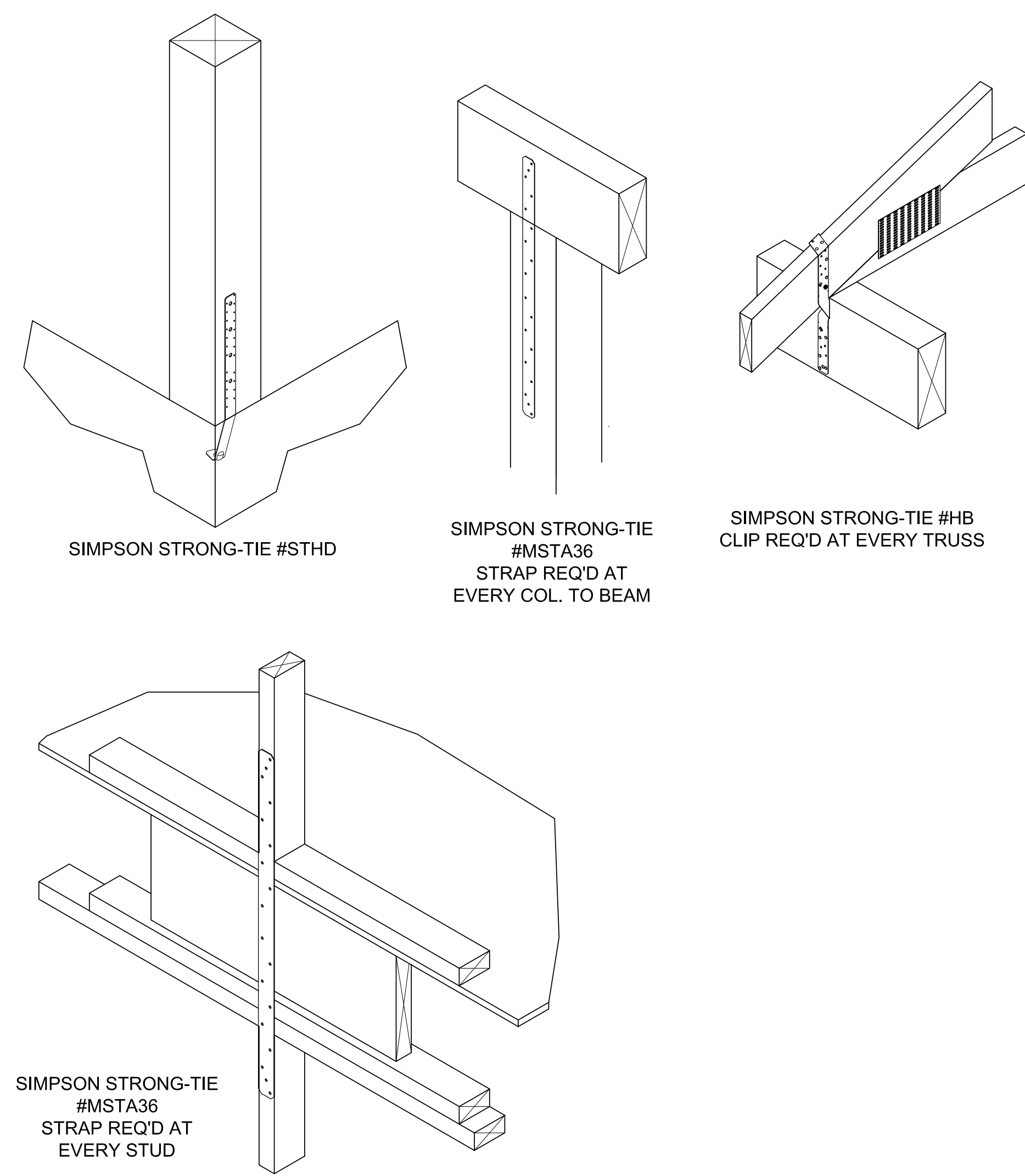
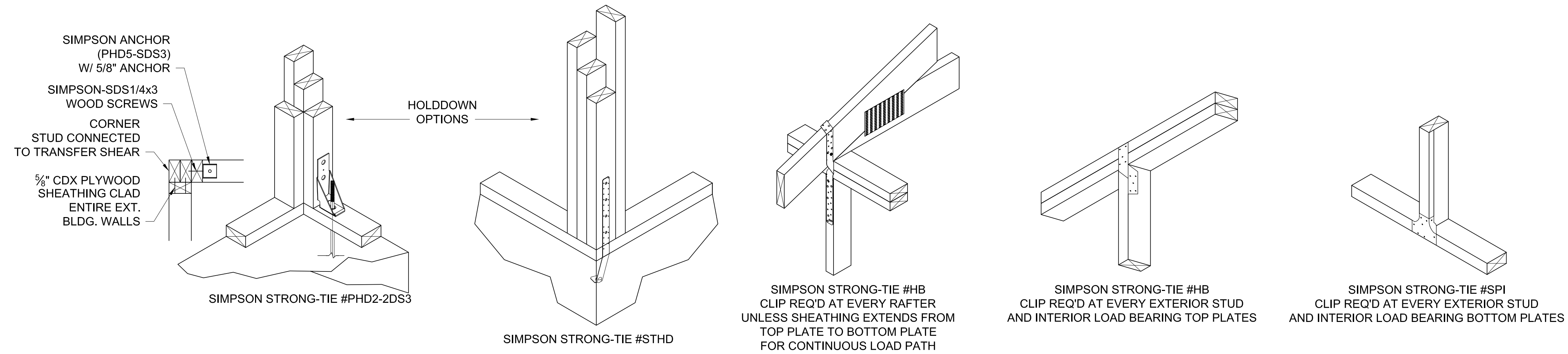

2 WIND STRAPPING
 NO SCALE

1 BLDG. SECTION
 3/4" = 1'-0"

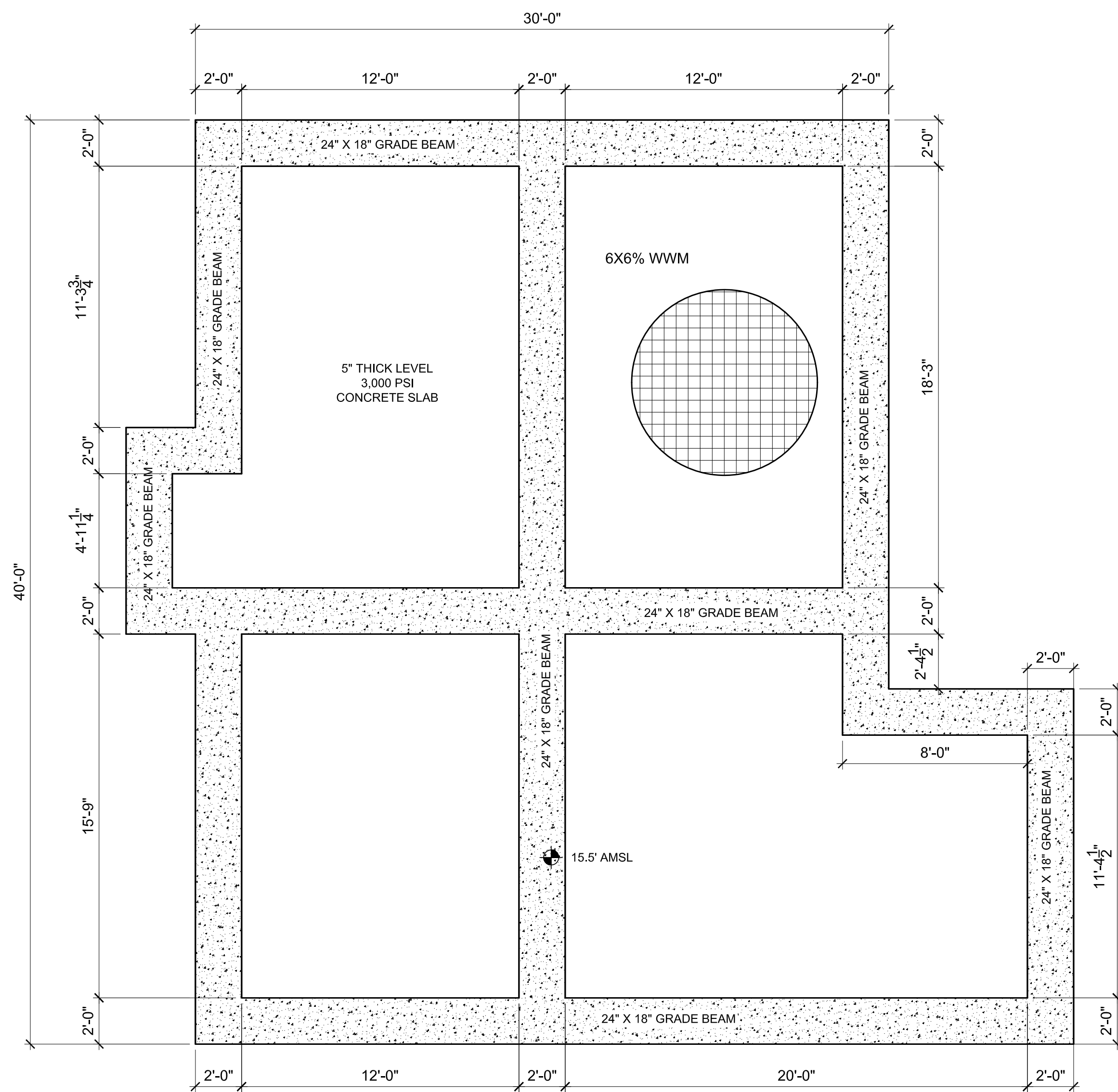

1 FOUNDATION PLAN
1/4" = 1'-0"

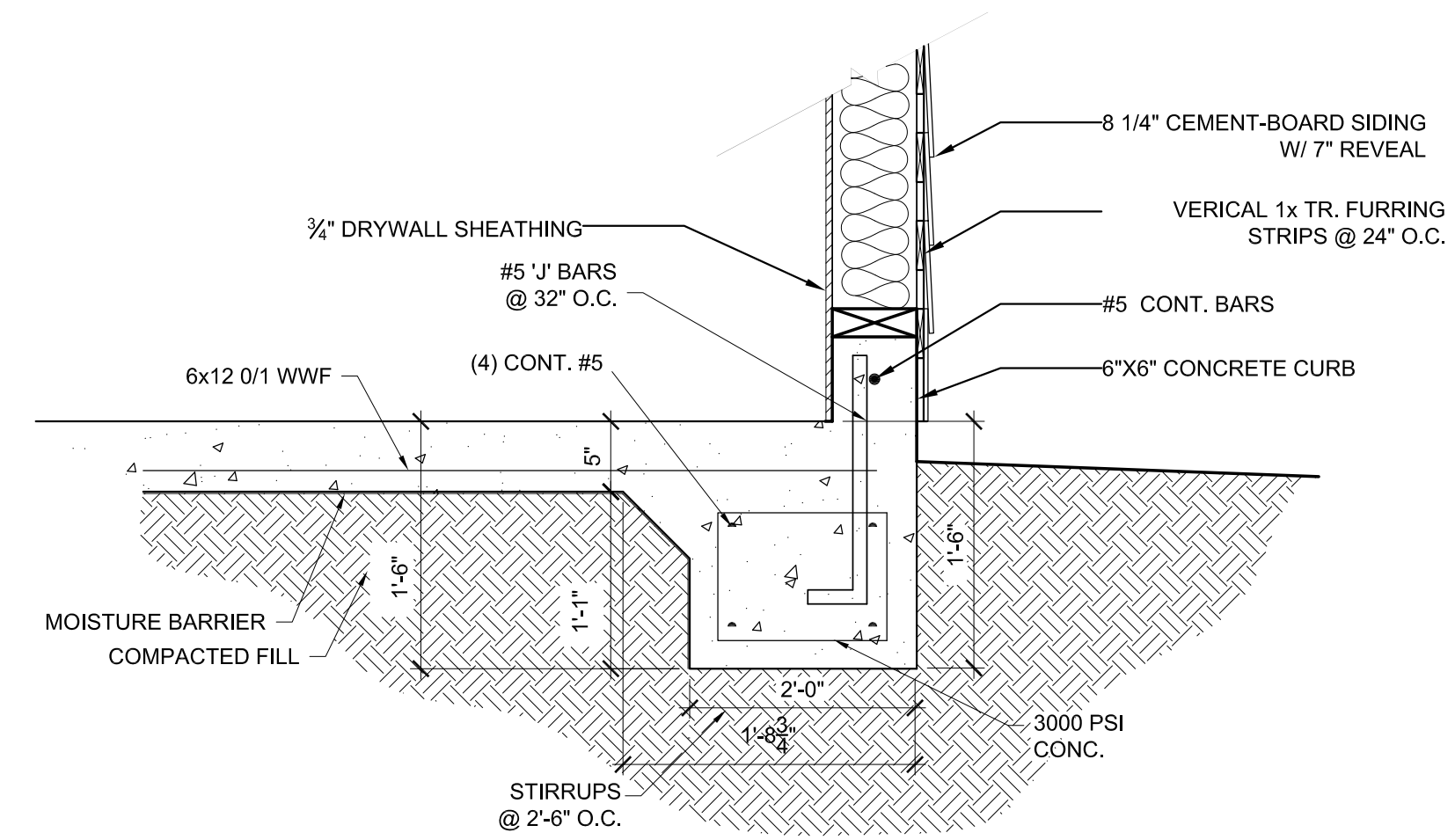

2 FOUNDATION DETAIL
1 1/2" = 1'-0"

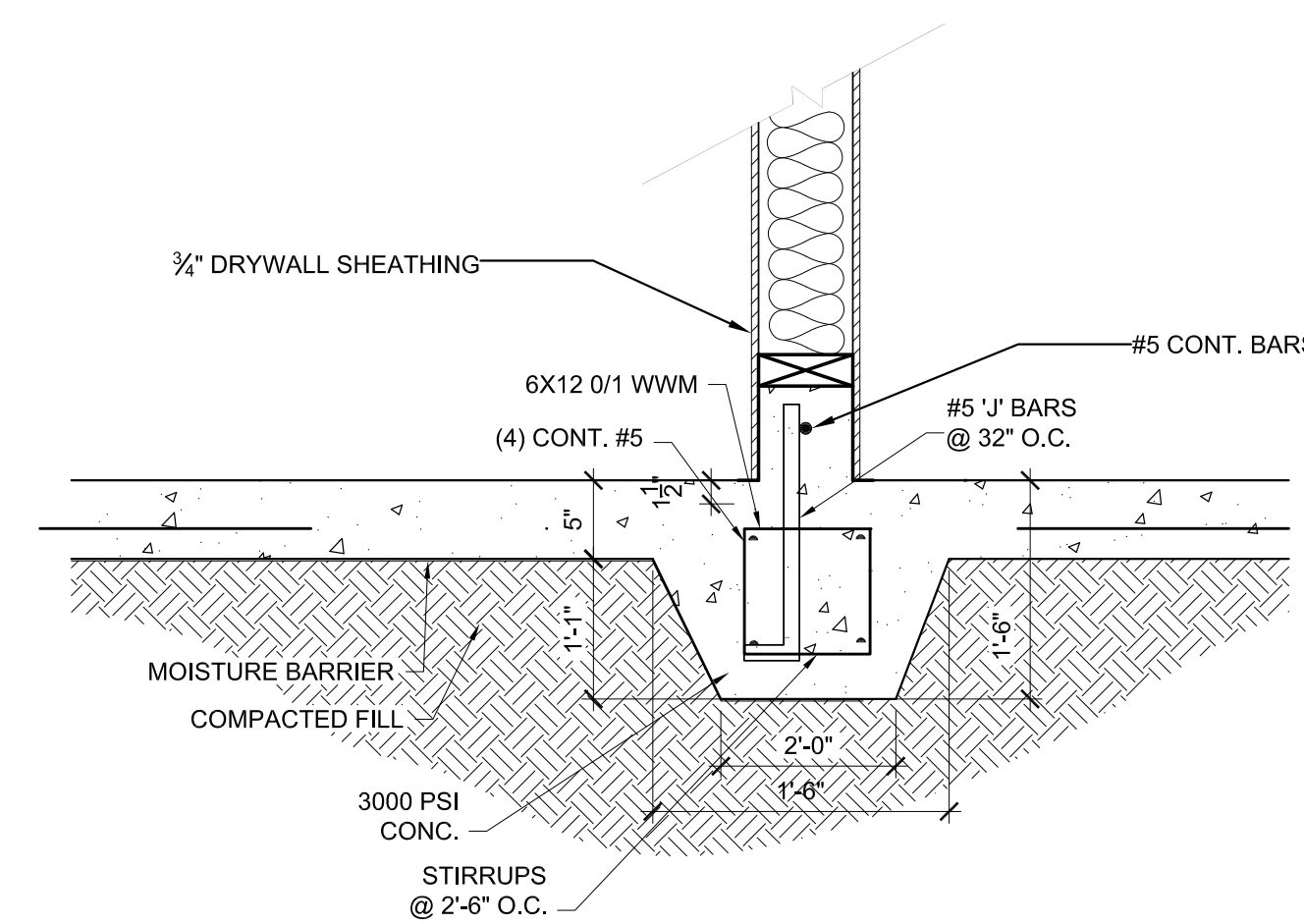

3 FOUNDATION DETAIL
1 1/2" = 1'-0"

FOUNDATION NOTES:

1. THE BEARING PRESSURE DESIGN FOR THIS STRUCTURE IS 1,500 PSF FOR SPREAD FOOTINGS & 2,000 PSF FOR CONTINUOUS FOOTINGS WHICH IS ACCOUNTED FOR AT APPROXIMATELY 2'-0" IN DEPTH. WE HAVE OBSERVED THE AREAS INFRASTRUCTURE DEVELOPMENT & DETERMINE THAT THE SOILS ARE NOT QUESTIONABLE AS PER ARTICLE 18022.1 OF THE 2015 IBC.
2. CONCRETE SHALL BE STANDARD WEIGHT & TEST AT 3,000 PSI AT 28 DAYS, IN ACCORDANCE WITH ACI 301 & 318. SUBMIT A DETAILED MIX DESIGN FOR REVIEW PRIOR TO CONSTRUCTION.
3. REINFORCING STILL SHALL BE NEW BILLET ASTM A 615 GRADE 60. DETAIL REINFORCING & PROVIDE ACCESSORIES IN ACCORDANCE WITH THE LATEST ACI MANUAL OF STANDARD PRACTICE. PROVIDE STANDARD 90 DEGREE HOOKS AT ALL TOP REINFORCEMENT. SUBMIT SHOP DRAWINGS FOR REVIEW PRIOR TO CONSTRUCTION.
4. ALL WELDED WIRE FABRIC SHALL BE IN ACCORDANCE WITH ASTM D 185 & SHALL BE PROVIDED IN SHEETS. THE MESH SHALL BE LAPPED TWO WIRE SPACES IN EACH DIRECTION & SHALL BE SUPPORTED BY 2 INCH CONCRETE BRICKS SPACED AT 36 INCHES APART EACH WAY.
5. PRIOR TO SITE PREPARATION, VERIFY THE LOCATION OF UTILITIES, RELOCATE UTILITIES WHICH ARE IN THE CONSTRUCTION AREA & CLEARLY MARK ANY UTILITIES ON OR NEAR THE SITE.
6. CONSTRUCTION & EXPANSION JOINTS DOWELED OR KEYPED FOR GOOD TRANSFER OF LOAD MUST BE PROPERLY SEALED TO PREVENT INTRUSION OF SURFACE WATERS INTO THE PAVEMENT BASE & NATURAL SUB.
7. ALL WORK TO BE IN ACCORDANCE WITH IRC, 2012 EDITION. ANY QUESTIONS OR CLARIFICATIONS REQUIRED TO BE SUBMITTED TO ARCHITECT FOR REVIEW.
8. STEEL STRUCTURE, PLATES, ANGLES, TUBES, PIPES, & MISCELLANEOUS SECTIONS TO COMPLY WITH CURRENT AISC MINIMUM STANDARDS.
9. EXPOSED STEEL COMPONENTS MUST BE HOT DIPPED GALVANIZED & PAINTED.
10. ALL WOOD FOUNDATION FRAMING, SILLS, JOISTS, STAIR COMPONENTS, BLOCKING, & TRIM, EXPOSED OR IN CONTACT WITH WOOD OR MASONRY TO BE PRESSURE TREATED WITH HOT DIPPED GALVANIZED STRAPS & FASTENERS & TO BE KILN DRIED #2 SOUTHERN YELLOW PINE.
11. CONCRETE TO PLATE OR HORIZONTAL BEAM SHALL BE SIMPSON STRONG TIE # MGT OR LMA 4 EACH MEMBER.



REVISIONS:

| | |
|-------------|---------|
| DATE: | 1.22.19 |
| PROJECT No: | 18027 |



| |
|----------------------|
| REVISIONS: |
| DATE: 1.22.19 |
| PROJECT No: 18027 |
| DRAWING: |

S2.0

FRAMING NOTES:

- ALL WORK TO BE IN ACCORDANCE WITH IRC, 2012 EDITION. ANY QUESTIONS OR CLARIFICATIONS REQUIRED TO BE SUBMITTED TO ARCHITECT FOR REVIEW.
- P. T. WOOD SILLS AND FLOOR STRUCTURE MUST BE SECURED WITH GALVANIZED FASTENERS IN ACCORDANCE WITH IRC 2012 CODE REQUIREMENTS. BASIC WIND LOAD DESIGN FOR THIS PROJECT IS TO BE 120 MPH.
- STEEL STRUCTURE, PLATES, ANGLES, TUBES, PIPES AND MISCELLANEOUS SECTIONS TO COMPLY WITH CURRENT AISC MINIMUM STANDARDS.
- EXPOSED STEEL COMPONENTS MUST BE HOT DIPPED GALVANIZED AND PAINTED.
- ALL WOOD FOUNDATION FRAMING, SILLS, JOISTS, STAIR COMPONENTS, BLOCKING AND TRIM EXPOSED OR IN CONTACT WITH WOOD OR MASONRY TO BE PRESSURE TREATED WITH HOT DIPPED GALVANIZED STRAPS AND FASTENERS.
- PROTECTION OF UTILITIES IN AND ADJACENT TO STRUCTURE SHALL BE THE RESPONSIBILITY OF CONTRACTOR. DAMAGE TO STRUCTURE AND UTILITIES SHALL BE REPAIRED BY CONTRACTOR.
- STUD TO SOLE PLATE & STUD TO DOUBLE TOP PLATE SHALL BE SIMPSON STRONG TIE #P1 EACH MEMBER
- JOISTS & RAFTERS TO DOUBLE TOP PLATE & RIDGE SHALL BE SIMPSON STRONG TIE #H8 EACH MEMBER
- HEADERS @ OPENINGS IN EXT. WALLS TO STUDS SHALL BE SIMPSON STRONG TIE #CS22 EACH SIDE.
- PROVIDE CONTINUOUS BLOCKING UNDERNEATH ALL INTERIOR WALLS, STAIRS, FIREPLACES, TUBS, ETC. AND INTERMEDIATE BLOCKING AT 6'-0" O.C. MAX.
- ALL RIDGES TO BE MIN 2X10 S.Y.P.
- ALL RAFTERS TO BE 2X8 @ 16" O.C. S.Y.P.
- ALL CLG. JOISTS TO BE 2X8 S.Y.P. @ 16" O.C.
- ALL ROOF PURLINS TO BE 2X6 @ 24" O.C.

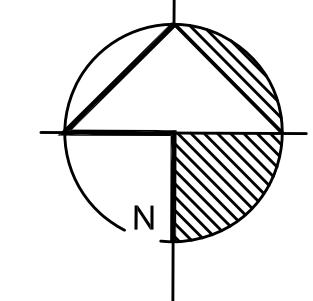
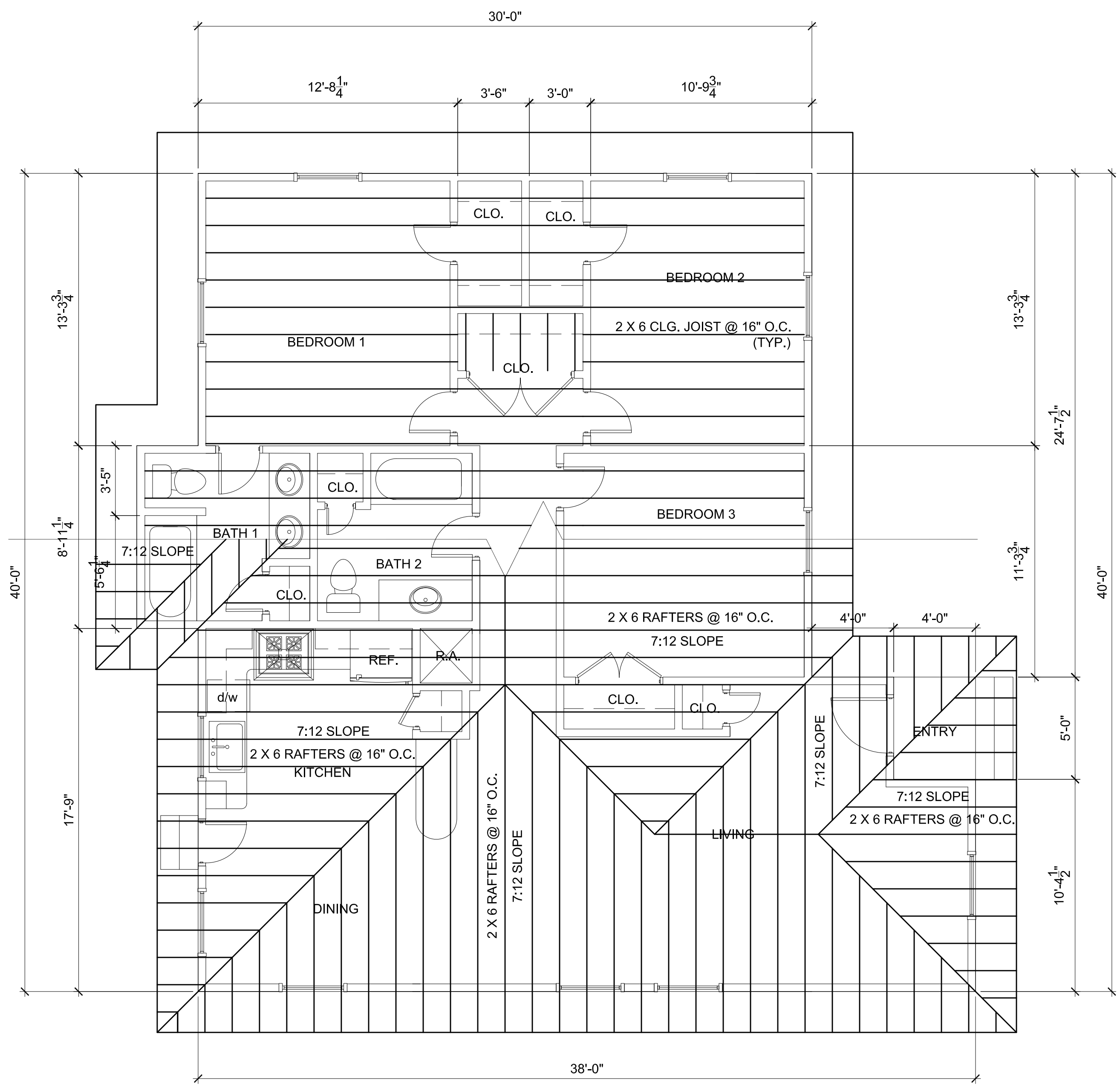

1 CEILING & ROOF FRAMING PLAN
 1/4" = 1'-0"

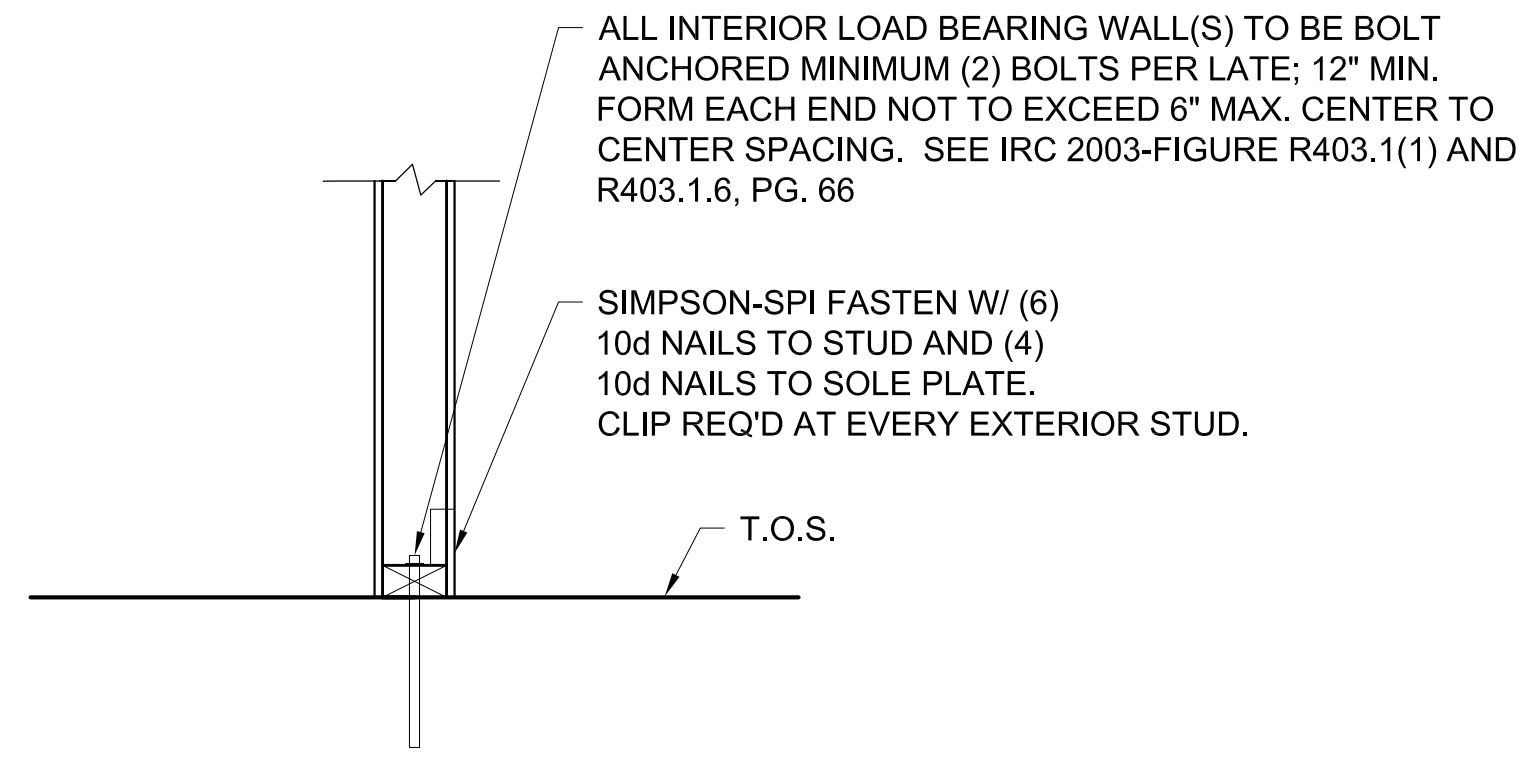

2 INTERIOR LOAD BEARING WALL DETAIL
 1 1/2" = 1'-0"

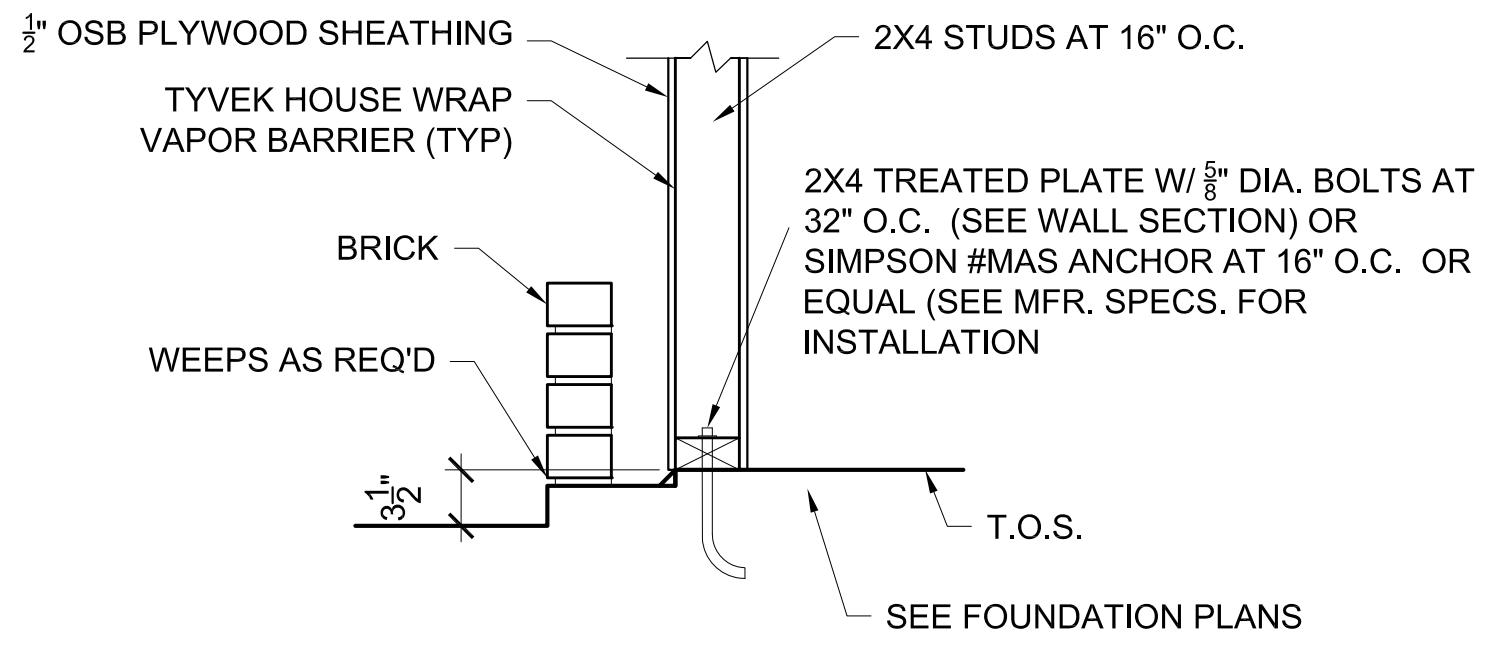

3 BRICK STUD WALL DETAIL
 1 1/2" = 1'-0"

PANELBOARD SCHEDULE

PANEL NAME: **120A**
 VOLTAGE: 120/208V, 1 PHASE, 3 WIRE
 MAIN: 120A MLO FULLY RATED
 A/C SYMMETRICAL INTERRUPTING BRACING: 10K
 ENCLOSURE: SURFACE WITH FRONT HINGED TO BOX STYLE DOOR, NEMA 1

QUANTITY OF SECTIONS: 2
 SERVICE ENTRANCE: NO

FEED THRU LUGS: NO
 200% NEUTRAL: NO
 FEED: BOTTOM
 EQUIPMENT GROUND BUS: YES
 ISOLATED GROUND BUS: NO

| DESCRIPTION | CONDUCTORS/ CONDUIT | TRIP AMP | POLE | NO. | PH | NO. | POLE | TRIP AMP | CONDUCTORS/ CONDUIT | DESCRIPTION |
|--------------------|------------------------|-------------|------|-----|----|-----|------|-------------|------------------------|-----------------|
| RECEPTACLES | 2 #12, 1 #12G | 20 | 1 | 1 | A | 2 | 1 | 20 | 2 #12, 1 #12G | RECEPTACLES |
| RECEPTACLES | 2 #12, 1 #12G | 20 | 1 | 3 | C | 4 | 1 | 20 | 2 #12, 1 #12G | RECEPTACLES |
| RECEPTACLES | 2 #12, 1 #12G | 20 | 1 | 5 | A | 6 | 1 | 20 | 2 #12, 1 #12G | RECEPTACLES |
| RECEPTACLES | 2 #12, 1 #12G | 20 | 1 | 7 | C | 8 | 1 | 20 | 2 #12, 1 #12G | RECEPTACLES |
| RECEPTACLES | 2 #10, 1 #10G | 30 | 1 | 9 | A | 10 | 1 | 20 | 2 #12, 1 #12G | RECEPTACLES |
| RECEPTACLES | 2 #10, 1 #10G | 30 | 1 | 11 | C | 12 | 1 | 20 | 2 #12, 1 #12G | RECEPTACLES |
| KITCHEN HOOD | 2 #12, 1 #12G | 20 | 1 | 13 | A | 14 | 1 | 20 | 2 #12, 1 #12G | RECEPTACLES |
| RECEPTACLES | 2 #12, 1 #12G | 20 | 1 | 15 | C | 16 | 1 | 30 | 2 #10, 1 #10G | RECEPTACLES |
| RECEPTACLES | 2 #10, 1 #10G | 20 | 1 | 17 | A | 18 | 1 | 30 | 2 #10, 1 #10G | RECEPTACLES |
| RECEPTACLES | 2 #12, 1 #12G | 20 | 1 | 19 | C | 20 | 1 | 20 | 2 #12, 1 #12G | RECEPTACLES |
| RECEPTACLES | 2 #12, 1 #12G | 20 | 1 | 21 | A | 22 | 1 | 20 | 2 #12, 1 #12G | RECEPTACLES |
| RECEPTACLES | 2 #12, 1 #12G | 20 | 1 | 23 | C | 24 | 1 | 20 | 2 #12, 1 #12G | RECEPTACLES |
| RECEPTACLES | 2 #12, 1 #12G | 20 | 1 | 25 | A | 26 | 1 | 20 | 2 #12, 1 #12G | RECEPTACLES |
| RECEPTACLES | 2 #12, 1 #12G | 20 | 1 | 27 | C | 28 | 1 | 20 | 2 #12, 1 #12G | RECEPTACLES |
| LIGHTS / EF 1 & 2 | 2 #12, 1 #12G | 20 | 1 | 29 | A | 30 | 1 | 20 | 2 #12, 1 #12G | LIGHTS |
| LIGHTS | 2 #12, 1 #12G | 20 | 1 | 31 | C | 32 | 1 | 20 | 2 #12, 1 #12G | LIGHTS |
| LIGHTS | 2 #12, 1 #12G | 20 | 1 | 33 | A | 34 | 1 | 20 | 2 #12, 1 #12G | LIGHTS |
| LIGHTS | 2 #12, 1 #12G | 20 | 1 | 35 | C | 36 | 1 | 20 | 2 #12, 1 #12G | EXTERIOR LIGHTS |
| WASHER | 2 #12, 1 #12G | 30 | 1 | 37 | A | 38 | 1 | 20 | 2 #8, 1 #10G | CU-1 |
| DRYER | 2 #8, 1 #10G | 50 | 2 | 39 | C | 40 | -- | -- | -- | -- |
| -- | -- | -- | -- | 41 | A | 42 | 2 | 25 | 2 #10, 1 #10G | AH-1 |
| GARAGE RECEPTACLES | 2 #12, 1 #12G | 20 | 1 | 43 | A | 44 | -- | -- | -- | -- |
| GARAGE DOORS | 2 #12, 1 #12G | 15 | 1 | 45 | C | 46 | 1 | 20 | 2 #12, 1 #12G | WATER HEATER |
| -- | -- | -- | -- | 57 | C | 58 | -- | -- | -- | -- |
| SPARE | -- | 20 | 1 | 59 | A | 60 | 1 | 20 | -- | SPARE |
| SPARE | -- | 20 | 1 | 61 | C | 62 | 1 | 20 | -- | SPARE |
| SPARE | -- | 20 | 1 | 63 | A | 64 | 1 | 20 | -- | SPARE |
| SPARE | -- | 20 | 1 | 65 | C | 66 | 1 | 20 | -- | SPARE |
| SPARE | -- | 20 | 1 | 67 | A | 68 | 1 | 20 | -- | SPARE |
| SPARE | -- | 20 | 1 | 69 | C | 70 | 1 | 20 | -- | SPARE |
| SPARE | -- | 20 | 1 | 71 | A | 72 | 1 | 20 | -- | SPARE |
| SPARE | -- | 20 | 1 | 73 | C | 74 | 1 | 20 | -- | SPARE |
| SPARE | -- | 20 | 1 | 75 | A | 76 | 1 | 20 | -- | SPARE |
| SPARE | -- | 20 | 1 | 77 | C | 78 | 1 | 20 | -- | SPARE |
| SPARE | -- | 20 | 1 | 79 | A | 80 | 1 | 20 | -- | SPARE |
| SPARE | -- | 20 | 1 | 81 | C | 82 | 1 | 20 | -- | SPARE |
| SPARE | -- | 20 | 1 | 83 | A | 84 | 1 | 20 | -- | SPARE |

PLUMBING NOTES:

- THE PLUMBING CONTRACTOR SHALL COORDINATE WITH THE ARCHITECT, GENERAL CONTRACTOR AND OTHER TRADES, ALL REQUIRED OPENINGS AND EXCAVATIONS. ALL REQUIRED OPENINGS IN FOUNDATIONS, FLOORS, WALLS, AND ROOFS SHALL BE DESIGNED INTO THE STRUCTURE INITIALLY BY THE USE OF SLEEVES, CURBS, ETC. CUTTING AND PATCHING SHALL BE HELD TO A MINIMUM.
- ALL WORK AND MATERIAL SHALL CONFORM TO THE LATEST GOVERNING CODES. VERIFY ALL EXISTING CONDITIONS IN FIELD PRIOR TO COMMENCING WORK. CONTRACTOR TO PAY ALL FEES ASSOCIATED WITH PLUMBING WORK AND TIE-INS.
- COORDINATE THE ROUTING AND LOCATIONS OF PLUMBING PIPING AND EQUIPMENT WITH ALL OTHER TRADES PRIOR TO INSTALLATION.
- VERIFY SYSTEM REQUIREMENTS ESTABLISHED BY GENERAL CONTRACTOR AND OWNER REGARDING UTILITIES TO EQUIPMENT AND FIXTURES SUPPLIED BY OTHERS AND PROVIDE NECESSARY COMPONENTS FOR PROPER INSTALLATION.
- WATER HEATERS TO BE ON-DEMAND, GAS FUELED, MOUNTED TO EXTERIOR WALLS IN LOCATIONS SHOWN.

MECHANICAL NOTES:

- ALL HEATING AND AIR CONDITIONING EQUIPMENT TO BE FURNISHED AND INSTALLED BY MECHANICAL CONTRACTOR.
- MECHANICAL CONTRACTOR TO SUBMIT MANUFACTURER PRODUCT DATA, DIAGRAMS, J-LOAD CALCULATIONS AS NECESSARY TO SATISFY REQUIREMENTS ESTABLISHED BY THE OWNER AND CODE REQUIREMENTS.
- MECHANICAL CONTRACTOR TO PAY ALL FEES ASSOCIATED WITH MECHANICAL WORK AND TIE-INS.
- EXACT LOCATION OF MECHANICAL UNITS, CHASES, DUCTWORK AND CONTROL COMPONENTS TO BE DETERMINED WITH THE COOPERATION OF GENERAL CONTRACTOR, HIS SUBCONTRACTORS AND WITH THE APPROVAL OF THE ARCHITECT.
- MANUFACTURER PRODUCT DATA TO INCLUDE, BUT NOT LIMITED TO, THE FOLLOWING: ELECTRIC HEATER, DUCTWORK, CONTROLS, GRILLES FOR RETURN AND SUPPLY AIR, DIFFUSERS AND REGISTERS, CONDENSING UNIT, ELECTRIC POWER AND CONTROL WIRING REQUIREMENTS, EXHAUST FANS, RETURN AIR SHIFTS, ROOF CURBS, HVAC PIPING, FASTENERS, FITTINGS, DRAINS AND TESTING OF INSTALLED EQUIPMENT.
- ALL MECHANICAL INSTALLATIONS MUST COORDINATE WORK OF THEIR TRADE WITH OTHER CONSTRUCTION AND PROVIDE NECESSARY COMPONENTS TO PROVIDE PROPERLY OPERATING SYSTEM.
- MECHANICAL CONTRACTOR SHALL BALANCE AND ADJUST DAMPERS, REGISTERS, DIFFUSERS, ETC. IN ORDER TO PROVIDE PROPERLY WORKING SYSTEM. MECHANICAL CONTRACTOR TO ADJUST / MODIFY SYSTEM IF REQUIRED TO SATISFY OWNER OR CODE REQUIREMENTS.

ELECTRICAL NOTES:

- ELECTRICAL CONTRACTOR SHALL MAKE NECESSARY ARRANGEMENTS WITH THE LOCAL POWER COMPANY FOR TEMPORARY POWER AND PERMANENT METER.
- ELECTRICAL CONTRACTOR TO PAY ALL FEES ASSOCIATED WITH ELECTRICAL WORK AND TIE-INS. CONTRACTOR SHALL CONFIRM WITH THE TELEPHONE COMPANY THAT THE SERVICE LOCATION, SIZE, ETC. MEETS THEIR REQUIREMENTS AND HAS THEIR APPROVAL.
- ALL ELECTRICAL WORK SHALL HAVE A ONE YEAR WARRANTY FROM THE DATE OF SUBSTANTIAL COMPLETION.
- ALL ELECTRICAL WORK SHALL BE PERFORMED BY A LICENSED ELECTRICIAN.
- ELECTRICAL WORK SHALL COMPLY WITH NFPA 70 (2012), NATIONAL ELECTRICAL CODE.
- GROUNDING SHALL CONFORM TO ARTICLE 250 OR THE NEC.
- ELECTRICAL WORK IN WET AREAS SHALL COMPLY WITH NFPA 70 - ARTICLE 680.
- ELECTRICAL CONTRACTOR TO BE RESPONSIBLE FOR THE SIZING AND FUNCTIONING OF THE PANELS AND ALL WIRING, SWITCHES, FIXTURES, ETC.
- THE MAIN FEEDERS SHALL BE GALVANIZED OR SHERARDIZED HEAVY WALL CONDUIT BRANCH CIRCUITS RUN IN EMT. ALL CONDUIT TO BE 1/2" UNLESS OTHERWISE SPECIFIED.
- ALL SAFETY SWITCHES SHALL BE HEAVY DUTY WESTINGHOUSE, OR APPROVED EQUAL.
- BATHROOM RECEPTACLES SHALL HAVE GFCI PROTECTION.
- OUTDOOR RECEPTACLES SHALL HAVE GFCI PROTECTION.
- ALL CONDUIT ABOVE GRADE LOCATED OUTSIDE OF BUILDING SHALL BE MINIMUM 3/4" RIGID GALVANIZED STEEL, UNLESS NOTED OTHERWISE.
- ALL CONDUIT BELOW GRADE SHALL BE A MINIMUM 1" SCHEDULE 40 PVC, BURIED A MINIMUM OF 18" IN AREAS NOT SUBJECT TO VEHICULAR TRAFFIC. INSTALL SEPARATE GREEN GROUND WIRE IN ALL PVC CONDUITS.
- POWER FOR HVAC EQUIPMENT TO BE INSTALLED AS PER MANUFACTURERS SPECIFICATIONS.
- MAIN GROUND ROD(S) SHALL BE 3/4" X 10' COPPER CLAD STEEL.
- GROUND GRID SYSTEM SHALL TIE TO COLD WATER PIPING.

1 TYPICAL PANEL SCHEDULE
NO SCALE

2 ELECTRIC SERVICE DIAGRAM
NO SCALE

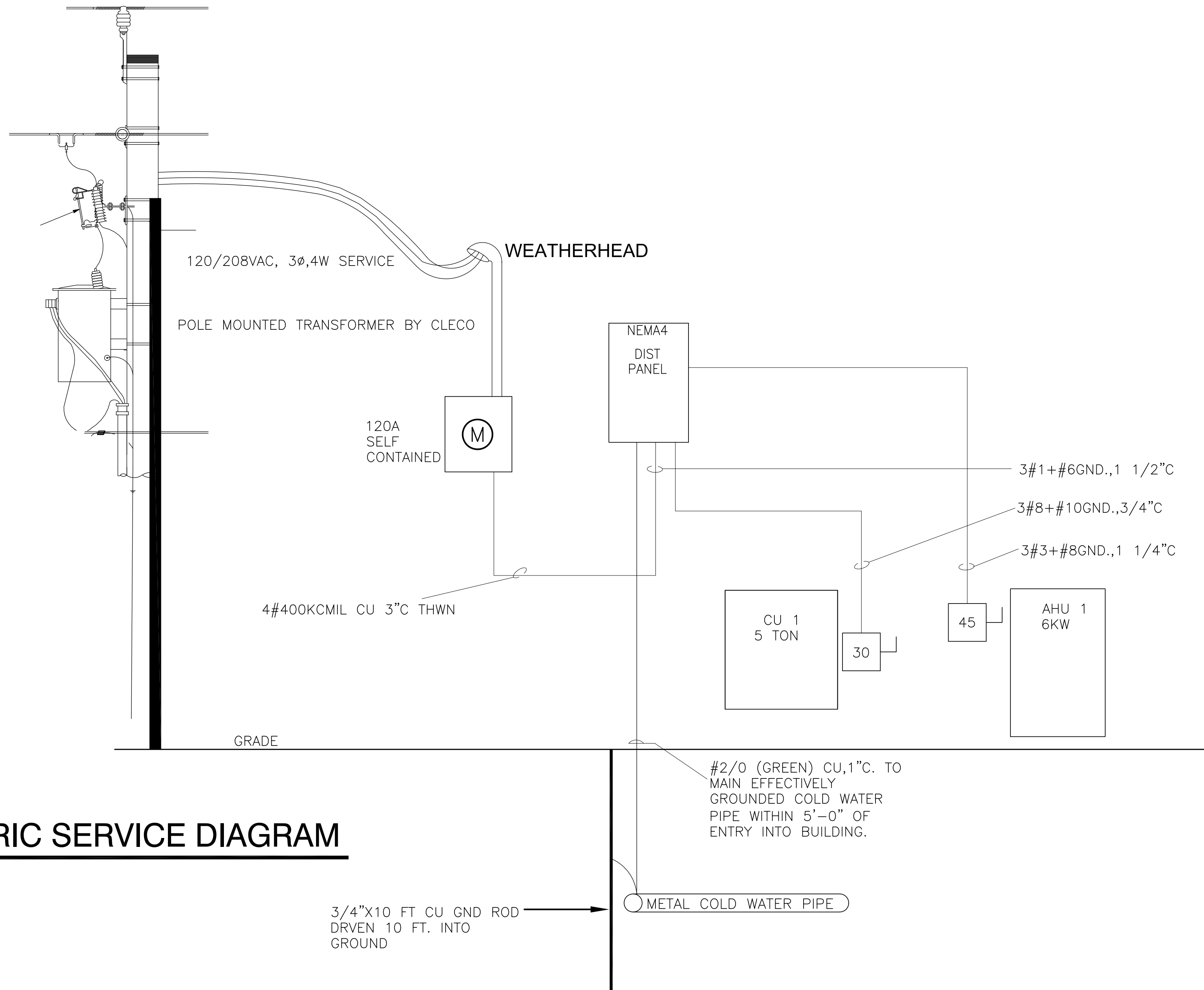

KVS architecture
 235 Girod Street, Mandeville, Louisiana
 985.674.3077 www.kvsarchitecture.com

RESIDENCE AT LOT 17 BETH DRIVE
 LOT 17 BETH DRIVE, SLIDELL, LOUISIANA



REVISIONS:
 DATE: 1.22.19
 PROJECT No: 18027
 DRAWING:

MEP