



**TABLE S102.7 - HEADER SPANS FOR INTERIOR LOAD-BEARING WALLS**

HEADERS SUPPORTING	SIZE	DROPPED HEADER			RAISED HEADER		
		BUILDING WIDTH (FT.)			BUILDING WIDTH (FT.)		
		12	24	36	12	24	36
ONE FLOOR ONLY (SINGLE CENTER BEARING WALL)	(2) 2x4	4'-0"	2'-10"	2'-4"	4'-1"	2'-10"	2'-4"
	(2) 2x6	5'-11"	4'-3"	3'-5"	6'-1"	4'-4"	3'-6"
	(2) 2x8	7'-1"	5'-2"	4'-4"	7'-4"	5'-5"	4'-5"
	(2) 2x10	7'-11"	6'-0"	5'-0"	9'-2"	6'-6"	5'-3"
	(2) 2x12	8'-6"	6'-7"	5'-7"	10'-4"	7'-7"	6'-3"
	(3) 2x8	8'-5"	6'-4"	5'-3"	9'-8"	6'-10"	5'-7"
	(3) 2x10	9'-3"	7'-11"	6'-10"	11'-5"	8'-11"	6'-7"
	(3) 2x12	9'-11"	7'-8"	6'-7"	13'-6"	9'-6"	7'-4"
	(4) 2x8	9'-5"	7'-2"	6'-0"	11'-2"	7'-11"	6'-5"
	(4) 2x10	10'-3"	7'-11"	6'-4"	13'-3"	9'-4"	7'-8"
(4) 2x12	11'-0"	8'-7"	7'-4"	15'-7"	11'-0"	9'-0"	

**TABLE S102.8 - HEADER SPANS FOR EXTERIOR LOAD-BEARING WALLS RESISTING WIND LOADS EXP "C"**

SIZE	120 MPH	130 MPH	140 MPH	150 MPH	160 MPH	170 MPH	180 MPH	195 MPH
(2) 2x4	5'-1"	4'-8"	4'-4"	4'-1"	3'-10"	3'-7"	3'-5"	3'-2"
(2) 2x6	6'-3"	5'-9"	5'-4"	5'-0"	4'-8"	4'-5"	4'-2"	3'-10"
(2) 2x8	6'-10"	6'-4"	5'-11"	5'-6"	5'-2"	4'-10"	4'-7"	4'-3"
(2) 2x10	7'-4"	6'-10"	6'-4"	5'-11"	5'-6"	5'-2"	4'-11"	4'-6"
(2) 2x12	7'-10"	7'-3"	6'-4"	6'-3"	5'-11"	5'-7"	5'-3"	4'-10"
(3) 2x8	8'-5"	7'-4"	7'-2"	6'-4"	6'-4"	5'-11"	5'-7"	5'-2"
(3) 2x10	9'-0"	8'-4"	7'-4"	7'-3"	6'-4"	6'-4"	5'-7"	5'-2"
(3) 2x12	9'-7"	8'-11"	8'-3"	7'-8"	7'-3"	6'-10"	6'-5"	5'-11"
(4) 2x8	9'-8"	9'-0"	8'-4"	7'-4"	7'-3"	6'-10"	6'-6"	6'-0"
(4) 2x10	10'-5"	9'-7"	8'-11"	8'-4"	7'-10"	7'-4"	6'-11"	6'-5"
(4) 2x12	11'-7"	11'-1"	10'-3"	9'-6"	8'-11"	8'-4"	7'-10"	6'-10"

**TABLE S102.9 - SILL OR BOTTOM PLATE TO FOUNDATION CONNECTIONS RESISTING UPLIFT LOADS - 140 MPH WIND EXP "C"**

BOTTOM PLATE TO FOUNDATION ANCHOR BOLT CONNECTION RESISTING	FOUNDATION SUPPORTING	MAXIMUM ANCHOR BOLT SPACING (INCHES)	
		8' END ZONES	INTERIOR ZONES
UPLIFT LOADS	1 - 3 STORIES	50 INCHES ON CENTER	50 INCHES ON CENTER

NOTE: A MINIMUM OF ONE ANCHOR BOLT SHALL BE PROVIDED WITHIN 6 TO 12 INCHES OF EACH END OF EACH PLATE.

**TABLE S102.10 - BOTTOM PLATE TO FOUNDATION CONNECTIONS (ANCHOR BOLTS) RESISTING LATERAL & SHEAR LOADS - EXP "C"**

BOTTOM PLATE TO FOUNDATION ANCHOR BOLT CONNECTION RESISTING	FOUNDATION SUPPORTING	MAXIMUM ANCHOR BOLT SPACING (INCHES)	
		1/2" Ø ANCHOR BOLTS	5/8" Ø ANCHOR BOLTS
UPLIFT LOADS	1 STORY	31 INCHES ON CENTER	48 INCHES ON CENTER

**TABLE S102.11 - FULL HEIGHT STUD REQUIREMENT FOR HEADERS OR WINDOW SILL PLATES IN EXTERIOR WALLS EXP "C"**

HEADER SPAN (FEET)	WALL STUD SPACING (INCHES)		
	12" O.C.	16" O.C.	24" O.C.
2	1	1	1
4	2	2	1
6	3	3	2
8	4	3	2
10	5	4	3
12	6	5	3
14	7	6	4
16	8	6	4

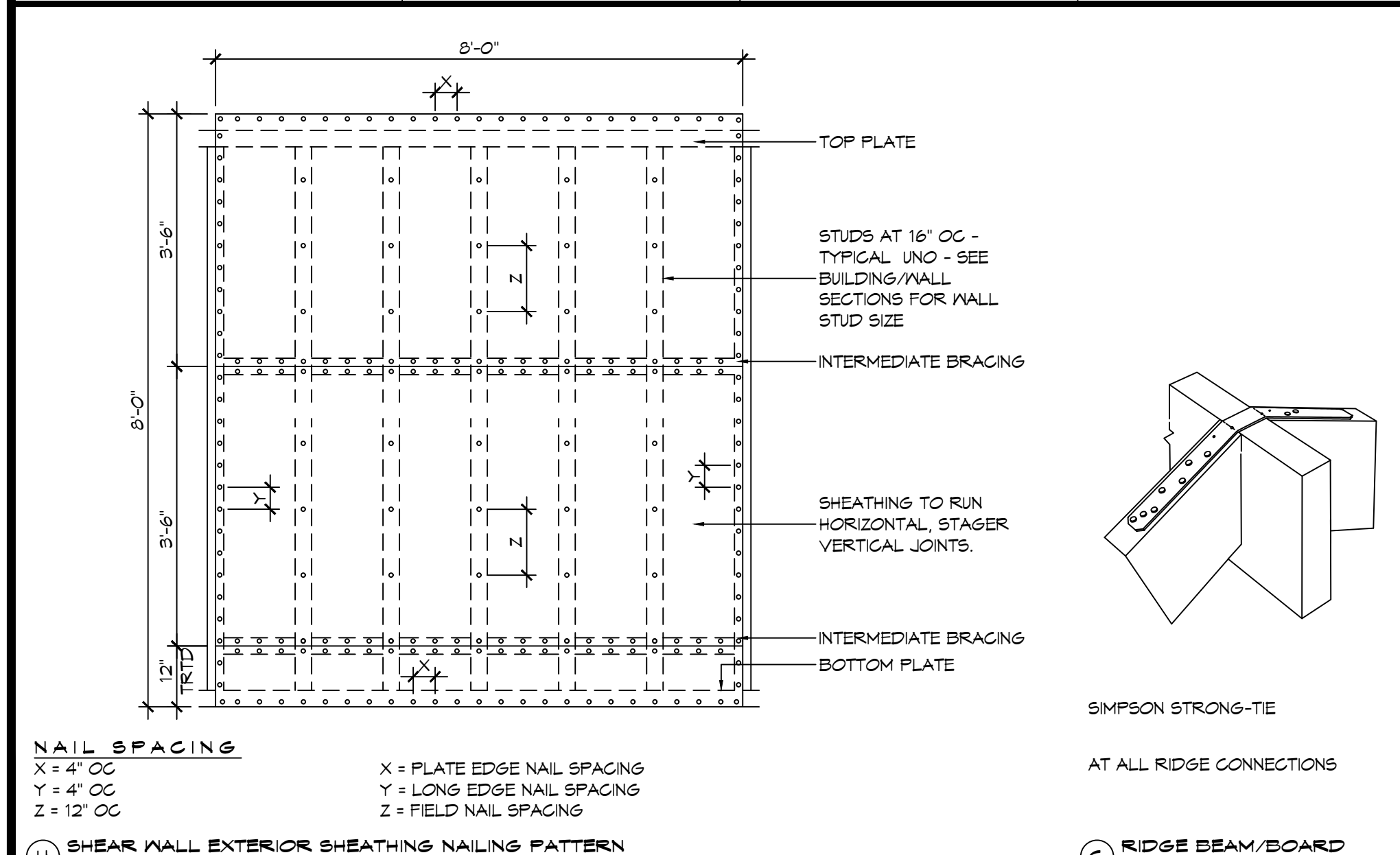

**TYPICAL CONNECTION DETAILS**  
SCALE: NTS

**TABLE S102.5 - JACK STUD REQ - INT LOADBEARING WALLS**

HEADER SUPPORTING	HEADER SPAN (FT)	ROOF SPAN (FEET)											
		12 FEET				24 FEET				36 FEET			
		HEADER WIDTH											
ONE FLOOR ONLY (CENTER BEARING)	2	1	1	1	1	1	1	1	1	1	1	1	1
	4	1	1	1	1	1	1	1	1	1	1	1	1
	6	1	1	1	1	1	1	1	1	1	2	1	1
	8	1	1	1	1	2	1	1	1	2	2	2	1
	10	1	1	1	1	2	2	1	1	3	2	2	2
	12	1	1	1	1	2	2	2	1	3	2	2	2
	14	2	1	1	1	3	2	2	2	4	3	3	2
	16	2	1	1	1	3	2	2	2	4	3	3	2
	4	1	1	1	1	2	1	1	1	3	2	2	2
	6	2	1	1	1	3	2	2	2	4	3	2	2
8	2	2	1	1	3	2	2	2	5	3	3	3	
10	2	2	2	1	4	3	3	2	6	4	4	3	
12	3	2	2	2	5	3	3	3	7	5	4	4	
14	3	2	2	2	6	4	4	3	8	5	5	4	
16	4	3	2	2	6	4	4	3	9	6	6	5	

HEADER WIDTH - 3" (2-2X), 4.5" (3-2X), 5", 6.5" (4-2X) EACH 1/2" PLYWOOD SPACER BETWEEN

**TABLE S102.6 - JACK STUD REQ - EXTERIOR LOADBEARING WALLS**

HEADER SUPPORTING	HEADER SPAN (FT)	ROOF LIVE LOAD 20 PSF				GROUND SNOW LOAD 30 PSF					
		NUMBER OF JACK STUDS REQUIRED									
		3"	4.5"	5"	6"	3"	4.5"	5"	6"		
ROOF AND CEILING	2	1	1	1	1	1	1	1	1	1	1
	4	1	1	1	1	1	1	1	1	1	1
	6	2	1	1	1	2	1	1	1	1	1
	8	2	2	2	1	2	2	2	1	1	1
	10	3	2	2	2	3	2	2	2	2	2
	12	3	2	2	2	3	2	2	2	2	2
	14	4	3	2	2	4	3	2	2	2	2
	16	4	3	3	2	4	3	3	2	2	2
	2	1	1	1	1	1	1	1	1	1	1
	4	2	1	1	1	2	1	1	1	1	1
6	2	2	2	1	3	2	2	2	2	2	
8	3	2	2	2	3	2	2	2	2	2	
10	4	3	2	2	4	3	3	2	2	2	
12	4	3	3	2	5	3	3	3	3	3	
14	5	4	3	3	5	4	3	3	3	3	
16	6	4	4	3	6	4	4	3	3	3	

HEADER WIDTH - 3" (2-2X), 4.5" (3-2X), 5", 6.5" (4-2X) EACH 1/2" PLYWOOD SPACER BETWEEN

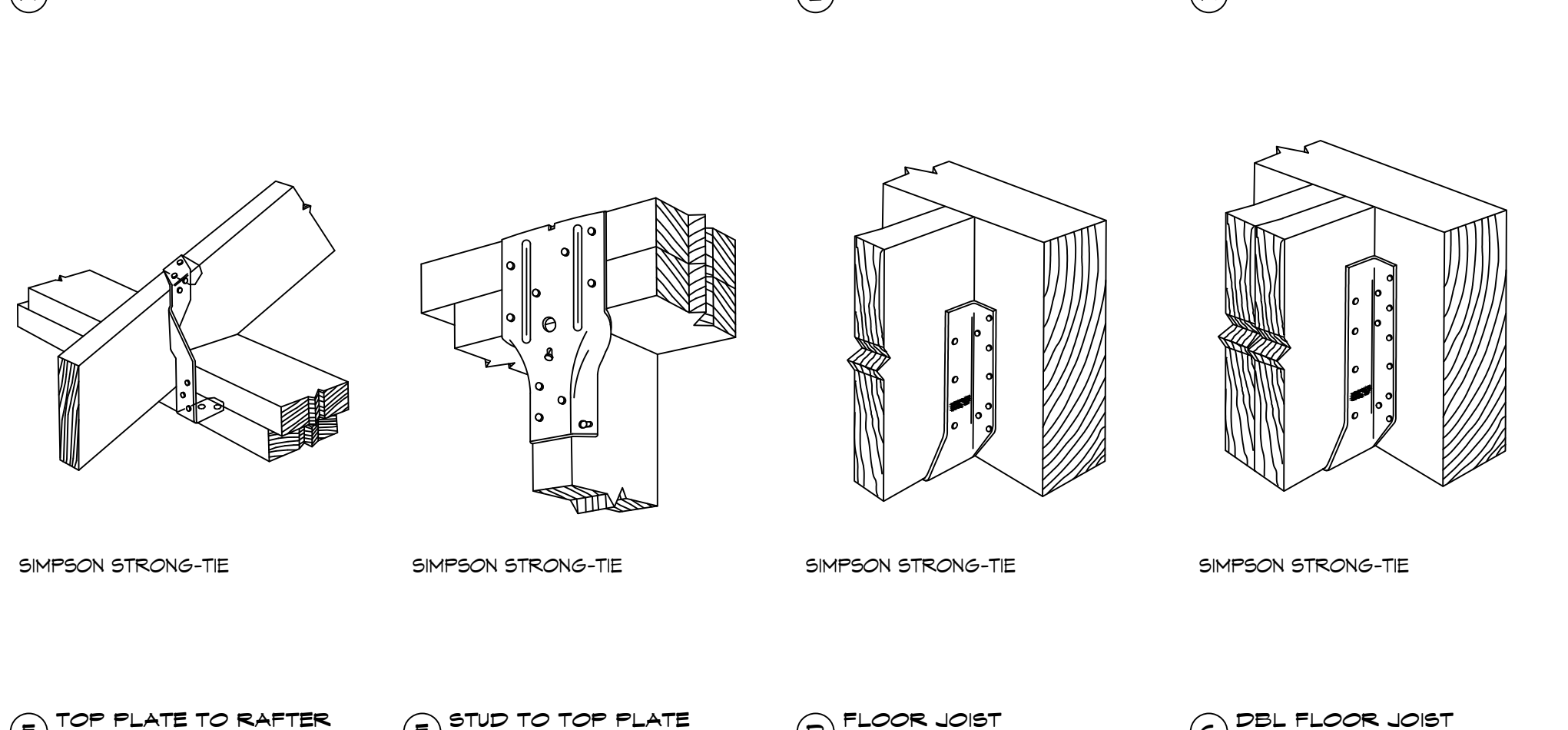
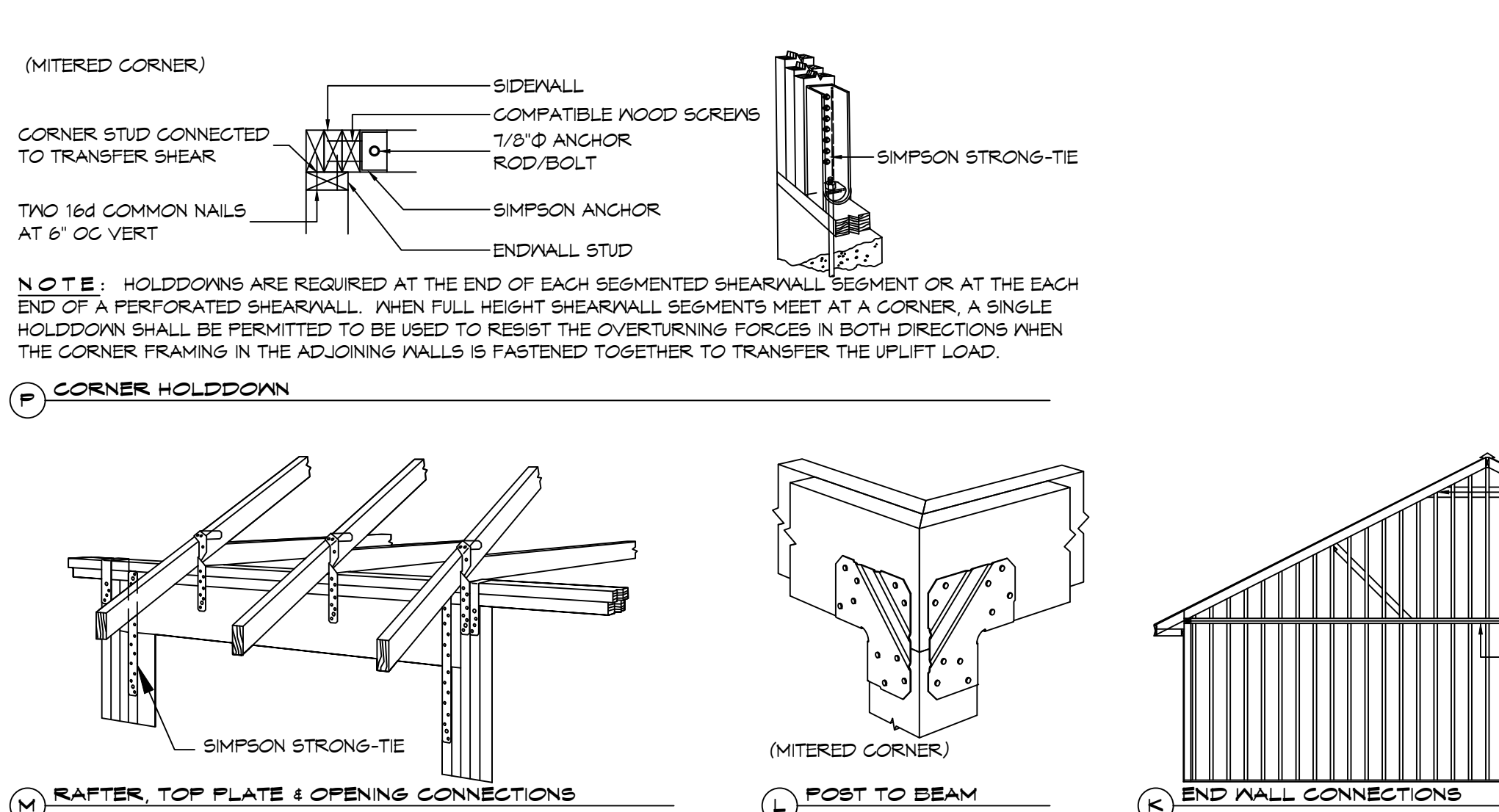

**TYPICAL CONNECTION DETAILS**

**TABLE S102.3 - NAILING SCHEDULE**

DESCRIPTION	NUMBER OF COMMON NAILS	NUMBER OF BOX NAILS	SPACING
<b>WALL FRAMING</b>			
TOP PLATE TO TOP PLATE (FACE NAILED)	2-16d	2-16d	PER FOOT
TOP PLATE AT INTERSECTION (FACE)	4-16d	5-16d	JOINTS - EACH SIDE
STUD TO STUD (FACE-NAILED)	2-16d	2-16d	24" O.C.
HEADER TO HEADER (FACE NAILED)	16d	16d	16" O.C. EDGES
TOP OR BOTTOM PLATE TO STUD (END)	SEE TABLE	SEE TABLE	PER STUD
BOTTOM PLATE TO FLOOR JOIST, BANDJOIST, END JOIST OR BLOCKING	2-16d	2-16d	PER FOOT
<b>ROOF SHEATHING</b>			
WOOD STRUCTURAL PANELS	8d	10d	SEE TABLE S102.1
DIAGONAL BOARD SHEATHING	1x6" OR 1x8"	2-8d	2-10d PER SUPPORT
1"x10" OR WIDER	3-8d	3-10d	PER SUPPORT

**TABLE S102.4 - BUILDING ENVELOPE REQUIREMENTS**

ROOFS	OPAQUE ELEMENTS	ASSEMBLY MAXIMUM	INSULATION MIN. R-VALUE
ROOFS	INSULATION ENTIRELY ABOVE DECK	U-0.048	R-20.0 c.i.
	METAL BUILDING	U-0.065	R-19
	ATTIC AND OTHER	U-0.027	R-30
WALLS, ABOVE GRADE	MASS	U-0.151 @	R-5.7 c.i. @
	METAL BUILDING	U-0.113	R-13.0
	STEEL-FRAMED	U-0.124	R-13.0
FLOORS	WOOD-FRAMED AND OTHER	U-0.089	R-13.0
	MASS	U-0.107	R6-3 c.i.
	STEEL JOIST	U-0.052	R-19.0
SLAB-ON-GRADE	WOOD FRAMED AND OTHER	U-0.051	R-19.0
	UN-HEATED	F-0.730	NR
OPAQUE DOORS	SPRINGING	U-0.700	NR
	NON-SPRINGING	U-1.450	NR

c.i. = CONTINUOUS INSULATION; NR = NO INSULATION REQUIREMENT  
@ = EXCEPTION APPLIES



**TABLE S102.1 - ROOF SHEATHING OR CLADDING REQUIREMENT - 140 MPH WIND LOAD EXP "C"**

SHEATHING LOCATION	RAFTER / TRUSS SPACING	MAX NAIL SPACING FOR 8d COMMON NAILS OR 10d BOX NAILS (INCHES O.C.)	
		E	F
INTERIOR ZONE	12" OC	6	12
	16" OC	6	12
	24" OC	6	12
PERIMETER EDGE ZONE	12" OC	6	12
	16" OC	6	12
	24" OC	6	6

110 MPH WIND - EXPOSURE 'C' TYPICAL  
E = NAIL SPACING AT PANEL EDGES, INCHES.  
F = NAIL SPACING AT INTERMEDIATE SUPPORTS IN THE PANEL FIELD, INCHES.

**TABLE S102.2 - WALL SHEATHING OR CLADDING REQUIREMENT - 140 MPH WIND LOAD EXP "C"**

SHEATHING LOCATION	STUD SPACING	MAX NAIL SPACING FOR 8d COMMON NAILS OR 10d BOX NAILS (INCHES O.C.)	
		E	F
INTERIOR ZONE	12" OC	6	12
	16" OC	6	12
	24" OC	6	12
PERIMETER EDGE ZONE	12" OC	6	12
	16" OC	6	12
	24" OC	6	12

110 MPH WIND - EXPOSURE 'C' TYPICAL  
E = NAIL SPACING AT PANEL EDGES, INCHES.  
F = NAIL SPACING AT INTERMEDIATE SUPPORTS IN THE PANEL FIELD, INCHES.

**DESIGN CRITERIA**  
THE CONSTRUCTION FOR SAID RESIDENCE, WHERE BASIC WIND SPEED IS 140 MILES PER HOUR, WIND EXPOSURE ZONE C, IS DESIGNED IN ACCORDANCE WITH: AMERICAN FOREST AND PAPER ASSOCIATION (AF&PA) WOOD FRAME CONSTRUCTION MANUAL FOR ONE AND TWO FAMILY DWELLINGS (MFCM) 2001 EDITION AS WELL AS THE INTERNATIONAL RESIDENTIAL CODE (IRC) 2021 EDITION

**ROOF UNDERLAYMENT NOTES**

- FOR ROOF SLOPES FROM TWO UNITS VERTICAL IN 12 UNITS HORIZONTAL (17-PERCENT SLOPE), UP TO FOUR UNITS VERTICAL IN 12 UNITS HORIZONTAL (33-PERCENT SLOPE), UNDERLAYMENT SHALL BE TWO LAYERS APPLIED IN THE FOLLOWING MANNER:
  - APPLY A 19 INCH STRIP OF UNDERLAYMENT FELT PARALLEL WITH AND STARTING AT THE EAVES, FASTENED SUFFICIENTLY TO HOLD IN PLACE. STARTING AT THE EAVE, APPLY 36 INCH WIDE SHEETS OF UNDERLAYMENT, OVERLAPPING SUCCESSIVE SHEETS 14 INCHES, AND FASTENED SUFFICIENTLY TO HOLD IN PLACE.
- FOR ROOF SLOPES OF FOUR UNITS VERTICAL IN 12 UNITS HORIZONTAL (33-PERCENT SLOPE) OR GREATER, UNDERLAYMENT SHALL BE ONE LAYER APPLIED IN THE FOLLOWING MANNER:
  - UNDERLAYMENT SHALL BE APPLIED SHINGLE FASHION, PARALLEL TO AND STARTING FROM THE EAVE AND OFFSET 2 INCHES, FASTENED SUFFICIENTLY TO HOLD IN PLACE. END LAPS SHALL BE OFFSET BY 6 FEET.

**SHINGLE APPLICATION & FASTENING NOTES**

- ASPHALT STRIP SHINGLES SHALL HAVE A MINIMUM OF SIX FASTENERS PER SHINGLE WHERE THE ROOF IS IN ONE OF THE FOLLOWING CATEGORIES:
  - THE BASIC WIND SPEED IS 110 MPH OR GREATER AND THE EAVE IS 20 FEET OR HIGHER ABOVE GRADE.
  - THE BASIC WIND SPEED IS 120 MPH OR GREATER.
  - SPECIAL WIND ZONES.

**GENERAL UPLIFT CONNECTION NOTES**

**ROOF ASSEMBLY TO WALL ASSEMBLY:**  
UPLIFT CONNECTIONS SHALL BE FROM RAFTER OR TRUSS TO WALL STUD. WHEN RAFTERS OR TRUSSES ARE NOT LOCATED DIRECTLY ABOVE STUDS, RAFTERS SHALL BE ATTACHED TO THE WALL PLATE AND THE WALL TOP PLATE SHALL BE ATTACHED TO THE WALL STUD WITH UPLIFT CONNECTIONS. UPLIFT CONNECTIONS SHALL BE IN ACCORDANCE WITH TABLE S102.10.

**WALL ASSEMBLY TO WALL ASSEMBLY:**  
STORY TO STORY UPLIFT CONNECTIONS FROM UPPER STORY WALL STUD TO LOWER STORY WALL STUD. WHEN UPPER STORY WALL STUDS ARE NOT LOCATED DIRECTLY ABOVE LOWER WALL STUDS, THE STUDS SHALL BE ATTACHED TO A COMMON MEMBER IN THE FLOOR ASSEMBLY BY UPLIFT CONNECTIONS. UPLIFT CONNECTIONS SHALL BE IN ACCORDANCE WITH TABLE S102.11.

**WALL ASSEMBLY TO FOUNDATION:**  
FIRST FLOOR WALL STUDS SHALL BE CONNECTED TO THE FOUNDATION, SILL, PLATE, OR BOTTOM PLATE. A MINIMUM OF A 1-1/4" x 20 GA. ASTM A653 GRADE 33 STEEL STRAP SHALL BE NAILED TO THE WALL STUDS AND HAVE A MINIMUM EMBEDMENT OF 1 INCHES IN CONCRETE FOUNDATIONS AND SLABS-ON-GRADE, 15 INCHES IN MASONRY BLOCK FOUNDATIONS, OR BE LAPPED UNDER THE BOTTOM PLATE, 3 INCH SQUARE WASHERS SHALL BE USED ON THE ANCHOR BOLTS AND ANCHOR BOLT SPACINGS SHALL NOT EXCEED THE REQUIREMENTS. STEEL STRAPS EMBEDDED IN OR IN CONTACT WITH SLAB-ON-GRADE OR MASONRY BLOCK FOUNDATIONS SHALL BE HOT-DIPPED GALV. AFTER FABRICATION, OR MANUF. FROM S105 OR Z450 GALV. STL. CONNECTIONS SHALL BE IN ACCORDANCE WITH TABLE S102.12.

**TABLE S102.1 - ROOF SHEATHING OR CLADDING REQUIREMENT - 140 MPH WIND LOAD EXP "C"**

SHEATHING LOCATION	RAFTER / TRUSS SPACING	MAX NAIL SPACING FOR 8d COMMON NAILS OR 10d BOX NAILS (INCHES O.C.)	
		E	F
INTERIOR ZONE	12" OC	6	12
	16" OC	6	12
	24" OC	6	12
PERIMETER EDGE ZONE	12" OC	6	12
	16" OC	6	12
	24" OC	6	6

110 MPH WIND - EXPOSURE 'C' TYPICAL  
E = NAIL SPACING AT PANEL EDGES, INCHES.  
F = NAIL SPACING AT INTERMEDIATE SUPPORTS IN THE PANEL FIELD, INCHES.

**TABLE S102.2 - WALL SHEATHING OR CLADDING REQUIREMENT - 140 MPH WIND LOAD EXP "C"**

SHEATHING LOCATION	STUD SPACING	MAX NAIL SPACING FOR 8d COMMON NAILS OR 10d BOX NAILS (INCHES O.C.)	
		E	F
INTERIOR ZONE	12" OC	6	12
	16" OC	6	12
	24" OC	6	12
PERIMETER EDGE ZONE	12" OC	6	12
	16" OC	6	12
	24" OC	6	12

110 MPH WIND - EXPOSURE 'C' TYPICAL  
E = NAIL SPACING AT PANEL EDGES, INCHES.  
F = NAIL SPACING AT INTERMEDIATE SUPPORTS IN THE PANEL FIELD, INCHES.

**DESIGN CRITERIA**  
THE CONSTRUCTION FOR SAID RESIDENCE, WHERE BASIC WIND SPEED IS 140 MILES PER HOUR, WIND EXPOSURE ZONE C, IS DESIGNED IN ACCORDANCE WITH: AMERICAN FOREST AND PAPER ASSOCIATION (AF&PA) WOOD FRAME CONSTRUCTION MANUAL FOR ONE AND TWO FAMILY DWELLINGS (MFCM) 2001 EDITION AS WELL AS THE INTERNATIONAL RESIDENTIAL CODE (IRC) 2021 EDITION

**DAMMON ENGINEERING, INC.**  
554 Old Spanish Trail  
Slidell, LA 70458  
PH: 985.649.8832  
www.dammonengineering.com  
info@dammonengineering.com

DATE: 08-30-2023  
JOB No: 2023  
DRAWN BY: CKD  
CHECKED BY: BAY

**FIRE RENOVATION**

SHEET TITLE: TYPICAL CONNECTION DETAILS, SCHEDULES, AND NOTES  
DRAWING NUMBER: S101  
SHEET No: 2 of 2