



# Unit Rating

2425 South Yukon Ave - Tulsa, Oklahoma 74107-2728 - Ph. (918) 583-2266 Fax (918) 583-6094  
AAONEcat32 Ver. 4.179 (SN: 7398336-5N81ANDE)

1A 1B 1C 1D 2 3 4 5A 5B 5C 6A 6B 6C 7 8 9 10 11 12 13 14A 14B 15 16 17 18 19 20 21 22 23  
**RN-013-2-0-FB09-13A:M000-U0B-DBC-B0A-CDMA00F-00-0000000AB**

**Tag: RTU# 1**

## Job Information

Job Name: *us department of agrig*  
 Job Number: *Job #450*  
 Site Altitude: *0 ft*  
 Refrigerant: *R-410A*

## Static Pressure

External: *0.75 in. wg.*  
 Evaporator: *0.09 in. wg.*  
 Filters Clean: *0.06 in. wg.*  
 Dirt Allowance: *0.35 in. wg.*

## Cooling Section

	Gross	Net
Total Capacity:	<i>152.82</i>	<i>151.21 MBH</i>
Sensible Capacity:	<i>74.30</i>	<i>72.69 MBH</i>
Latent Capacity:	<i>78.52 MBH</i>	
Mixed Air Temp:	<i>95.00 °F DB</i>	<i>80.00 °F WB</i>
Entering Air Temp:	<i>95.00 °F DB</i>	<i>80.00 °F WB</i>
Lv Air Temp (Coil):	<i>53.75 °F DB</i>	<i>53.55 °F WB</i>
Lv Air Temp (Unit):	<i>54.59 °F DB</i>	<i>53.90 °F WB</i>
Digital Comp. Capacity Ratio:	<i>100%</i>	
Supply Air Fan:	<i>1 x RN150 @ 0.54 BHP</i>	
SA Fan RPM / Width:	<i>1525 / 3.326"</i>	
Evaporator Coil:	<i>14.6 ft² / 6 Rows / 12 FPI</i>	
Evaporator Face Velocity:	<i>120.0 fpm</i>	

## AHRI Listing Information

Cooling Capacity (MBH): *144.0*  
 Cooling EER: *11.9*  
 Cooling IEER: *14*  
**Application EER @ Op. Conditions: *12.1***

## Electrical Data

Rating: *230/3/60*  
 Unit FLA: *76*

Minimum Circuit Amp: *96*  
 Maximum Overcurrent: *100*

	Qty	HP	VAC	Phase	RPM	FLA	RLA
Compressor 1:	1		230	3			20.4
Compressor 2:	1		230	3			22.4
Condenser Fans:	2	1.00	230	1	1100	7.4	
Supply Fan:	1	1.00	230	3	1760	4.2	

## Cabinet Sound Power Levels\*

Octave Bands:	63	125	250	500	1000	2000	4000	8000
Discharge LW(dB):	76	75	78	73	66	65	60	54
Return LW(dB):	67	62	64	56	52	49	43	32

\*Sound power levels are given for informational purposes only. The sound levels are not guaranteed.

## Unit Information

Approx. Op./Ship Weights: *1775 / 1775 lbs.*  
 Supply CFM/ESP: *1750 / 0.75 in. wg.*  
 Final-Filter FV / Qty: *126.00 fpm / 4*  
 Outside CFM: *1750*  
 Ambient Temperature: *95 °F DB / 80 °F WB*

Economizer: *0.00 in. wg.*  
 Heating: *0.02 in. wg.*  
 Cabinet: *0.01 in. wg.*  
 Re-Heat Coil: *0.01 in. wg.*  
 Total: *1.29 in. wg.*

## Heating Section

PreHeat Type: *Std (No Preheat)*  
 Heating Type: *Electric Heat*  
 Heating CFM: *1750*  
 Total Capacity: *102.4 MBH*  
 OA Temp: *25.0 DB / 24.0 °F WB*  
 RA Temp: *75.0 °F DB / 62.0 °F WB*  
 Entering Air Temp: *25.0 °F DB / 24.0 °F WB*  
 Leaving Air Temp: *79.1 °F DB / 52.5 °F WB*  
 Input: *30.0 kW*  
 Heater Qty: *3*  
 Electric Heat FLA: *72.2*

## Re-Heat Coil:

Capacity: *31 MBH*  
 LA DB / WB: *70.00 °F / 59.87 °F*  
 RH: *56%*



# 15.0" STAR Plenum

2425 South Yukon Ave - Tulsa, Oklahoma 74107-2728 - Ph. (918) 583-2266 Fax (918) 583-6094  
AAONEcat32 Ver. 4.179 (SN: 7398336-5N81ANDE)

## JOB INFORMATION:

Job Name: *us department of agrig*  
 Job Tag: *RTU# 1*  
 Rep Firm:  
 Date: *02/16/2012*

## WHEEL SPECIFICATION:

Max RPM: *2,200*  
 Diameter x Qty: *15.0 in. x 1*  
 CFM: *1750*  
 Tip Speed: *5,989 FPM*  
 Inertia: *3 WR<sup>2</sup>*

## OPERATING CONDITIONS:

Air Flow: *1,750 CFM*  
 Static Pressure: *1.29 in. Wg.*  
 Relief Dampers DP: *0.00 in. Wg.*  
 TSP: *1.29 in. Wg.*  
 Site Altitude: *0.00 Ft*  
 TSP @ Sea Level: *1.29 in. Wg.*

## MOTOR SELECTION:

Rated HP / Bypass: *1 / No*  
 Frame Size: *143T*  
 Nominal RPM: *1760*  
 VAC/PH/HZ: *230/3/60*  
 Efficiency: *Premium / 0.855*  
 Enclosure Type: *ODP*  
 Max Inertial Load: *15 WR<sup>2</sup>*

## FAN PERFORMANCE:

RPM: *1525*  
 BHP: *0.54*  
 Efficiency: *65.6%*  
 In/Out Velocity: *1522/1591 FPM*  
 Plenum Out Velocity: *29 FPM*

## FAN SOUND POWER (Inlet/Outlet):

Octave Band:	(Re 10 <sup>-12</sup> watts)							
	1	2	3	4	5	6	7	8
	76	75	78	75	69	68	64	58
	76	75	78	75	69	68	64	58

SOUND POWER A-Weighted: *78 / 78 dB*

Supply Fan Model: RN150 @ 1525 RPM and 99% Width  
 Design Conditions: 1750 CFM @ 1.29" SP

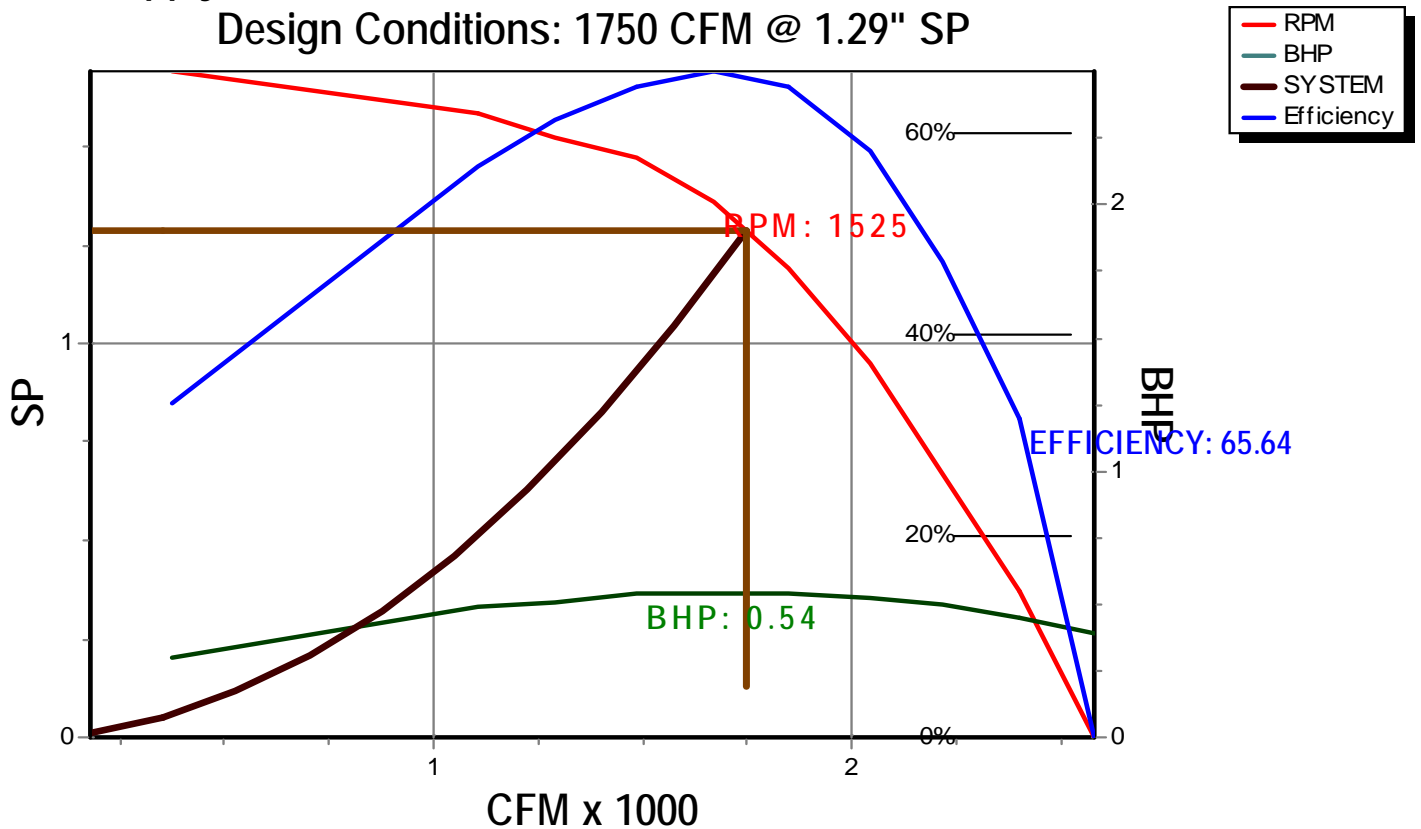



# Unit Submittal

2425 South Yukon Ave - Tulsa, Oklahoma 74107-2728 - Ph. (918) 583-2266 Fax (918) 583-6094  
AAONEcat32 Ver. 4.179 (SN: 7398336-5N81ANDE)

1A 1B 1C 1D 2 3 4 5A 5B 5C 6A 6B 6C 7 8 9 10 11 12 13 14A 14B 15 16 17 18 19 20 21 22 23

**RN-013-2-0-FB09-13A:M000-U0B-DBC-B0A-CDMA00F-00-0000000AB**

Tag: RTU# 1

Job Name:  
Job Number:

us department of agrig  
Job #450

Unit Submittal For:  
Unit Submittal Date:

February 16, 2012

	Base Option	Description
<b>R</b>	Series	Roof Top Unit
<b>N</b>	Generation	Ninth Generation
<b>013</b>	Unit Size	Thirteen
<b>2</b>	Voltage	230V/3Ø/60Hz
<b>0</b>	Interior Protection	Standard
<b>F</b>	Refrigerant Style	R-410A VCC - Standard Efficiency
<b>B</b>	Unit Configuration	Air-Cooled Cond. + 6 Row Evap. Coil
<b>0</b>	Coil Coating	Standard
<b>9</b>	Cooling/Heat Pump Staging	Modulating - 1 VCC + 1 On/Off Comp.
<b>1</b>	Heating Type	Electric Heat
<b>3</b>	Heating Designation	Heat 3 - 30 kW
<b>A</b>	Heating Staging	Modulating/SCR Electric - 0-10V Control Signal

	Feature Option	Description
<b>M</b>	1A. RA/OA Section	Motorized 100% Outside Air Dampers - No RA Opening
<b>0</b>	1B. RA/EA Blower Configuration	Standard - None
<b>0</b>	1C. RA/EA Blower	Standard - None
<b>0</b>	1D. RA/EA Blower Motor	Standard - None
<b>U</b>	2. OA Control	2 Position Actuator
<b>0</b>	3. Heat Options	Standard
<b>B</b>	4. Maintenance Options	115V Convenience Outlet - Factory Wired
<b>D</b>	5A. SA Blower Configuration	1 Blower + Premium Efficiency Motor + 1 VFD
<b>B</b>	5B. SA Blower	15" Direct Drive Backward Curved Plenum
<b>C</b>	5C. SA Motor	1.0 hp - 1760 rpm
<b>B</b>	6A. Pre Filter Type	Metal Mesh OA Pre Filter
<b>0</b>	6B. Unit Filter Type	2" Pleated - 30% Eff
<b>A</b>	6C. Filter Options	Clogged Filter Switch
<b>C</b>	7. Refrigeration Control	Fan Cycling
<b>D</b>	8. Refrigeration Options	Modulating Hot Gas Reheat
<b>M</b>	9. Refrigeration Accessories	ECM Condenser Fan - Head Pressure Control + Sight Glass + Compressor Isolation Valves
<b>A</b>	10. Power Options	Power Switch - 100 amps
<b>0</b>	11. Safety Options	Standard
<b>0</b>	12. Controls	Standard
<b>F</b>	13. Special Controls	Make Up Air Unit Controller - CV Cool + CV Heat
<b>0</b>	14A. Preheat Configuration	Standard - None
<b>0</b>	14B. Preheat Sizing	Standard - None
<b>0</b>	15. Glycol Percent	Water or No WSHP
<b>0</b>	16. Interior Cabinet Options	Standard - Double Wall + R-13 Foam Insulation + Stainless Steel Drain Pan
<b>0</b>	17. Exterior Cabinet Options	Standard
<b>0</b>	18. Customer Code	Standard
<b>0</b>	19. Code Options	Standard - ETL U.S.A. Listing
<b>0</b>	20. Crating	Standard
<b>0</b>	21. Water-Cooled Cond.	Standard - None
<b>A</b>	22. Control Vendors	Wattmaster Controls
<b>B</b>	23. Type	Standard - Includes AAON Gray Paint



# VCMX Components

2425 South Yukon Ave - Tulsa, Oklahoma 74107-2728 - Ph. (918) 583-2266 Fax (918) 583-6094  
AAONEcat32 Ver. 4.179 (SN: 7398336-5N81ANDE)

1A 1B 1C 1D 2 3 4 5A 5B 5C 6A 6B 6C 7 8 9 10 11 12 13 14A 14B 15 16 17 18 19 20 21 22 23

**RN-013-2-0-FB09-13A:M000-U0B-DBC-B0A-CDMA00F-00-0000000AB**

Tag: RTU# 1

Job Name: *us department of agrig*

VCMX For:

Job Number: *Job #450*

VCMX Date:

*February 16, 2012*

### Hardware Included For VCMX Controller

Part #	Included Parts	Assigned Channel
V07150	VCMX Controller with EBUS	
R28390	Suction Pressure Transducer	MainController\AI5
R82890	Supply Air Temp Sensor - Field Installed	MainController\AI2
R81550	Outside Air Temp Sensor	MainController\AI4
R69190	VCMX Large Expansion Module	
P62520	Proof of Flow Sensor	LargeExpansionModule\BI3
P62520	Dirty Filter Sensor	LargeExpansionModule\BI2
R34700	Outside Air Humidity Sensor	LargeExpansionModule\AI1
R90230	VCMX Head Pressure Module	
R22020	Head Pressure Sensor	
R22020	Head Pressure Sensor	

	1	2	3	4	5	6	7
VCMX Controller with EBUS	Analog In	X		X	X		
	Analog Out	X	X				
	Binary In						
	Relay Out	X	X	X	X		
	Digital Sensor(s)						

	1	2	3	4	5	6	7	8
VCMX Large Expansion Module	Analog In	X						
	Analog Out		X	X				
	Binary In		X	X				
	Relay Out							

# RN SERIES B - CABINET STANDARD ~ 9-15 TON

CLEARANCES	
LOCATION	◦ UNIT SIZE ◦ 9 - 15 TON
OUTSIDE AIR (BACK)	48
CONTROLS SIDE (FRONT)	48
LEFT SIDE	6
RIGHT SIDE	48
TOP	UNOBSTRUCTED

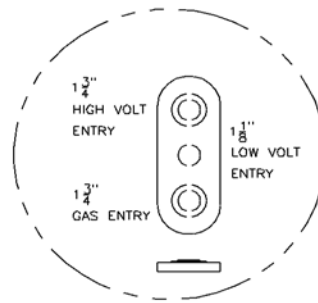

DETAIL A

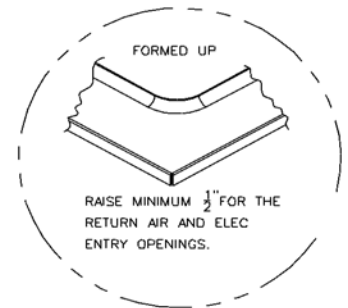

DETAIL B

### NUMBER OF CONDENSER FANS

9 & 11 TON - 1 FAN

13 & 15 TON - 2 FANS

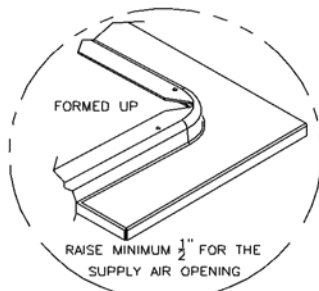

DETAIL C

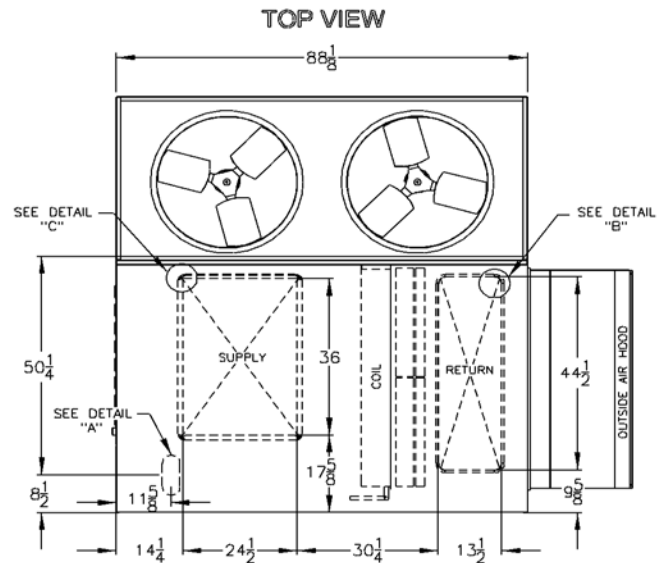

### FRONT VIEW

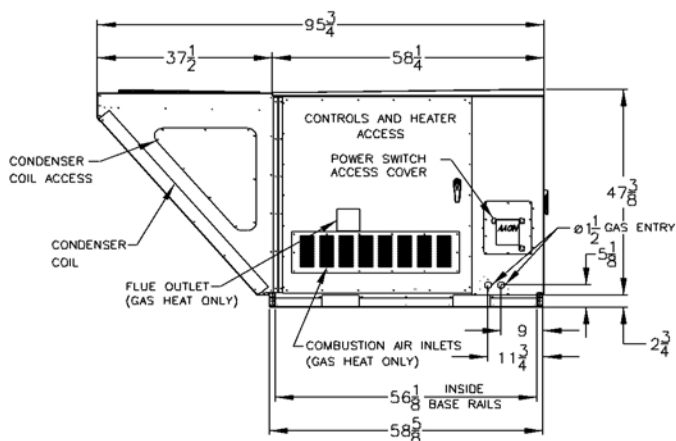

### RIGHT SIDE VIEW

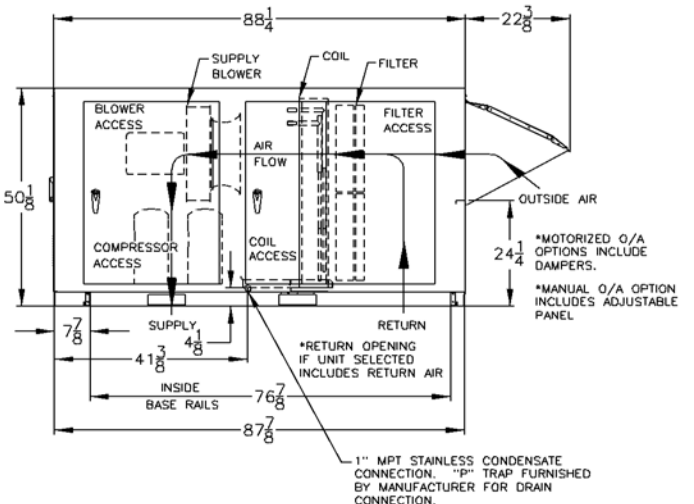

RNB-0001 REV:A 10/13/09 SJS  
NOTE: ALL DIMENSIONS ARE IN INCHES

1" MPT STAINLESS CONDENSATE CONNECTION. "P" TRAP FURNISHED BY MANUFACTURER FOR DRAIN CONNECTION.

# RNB CABINET AIR COOLED CONDENSING UNIT



RN-013-2-0-FB09-13A:M000-U0B-DBC-B0A-CDMA00F-00-0000000AB

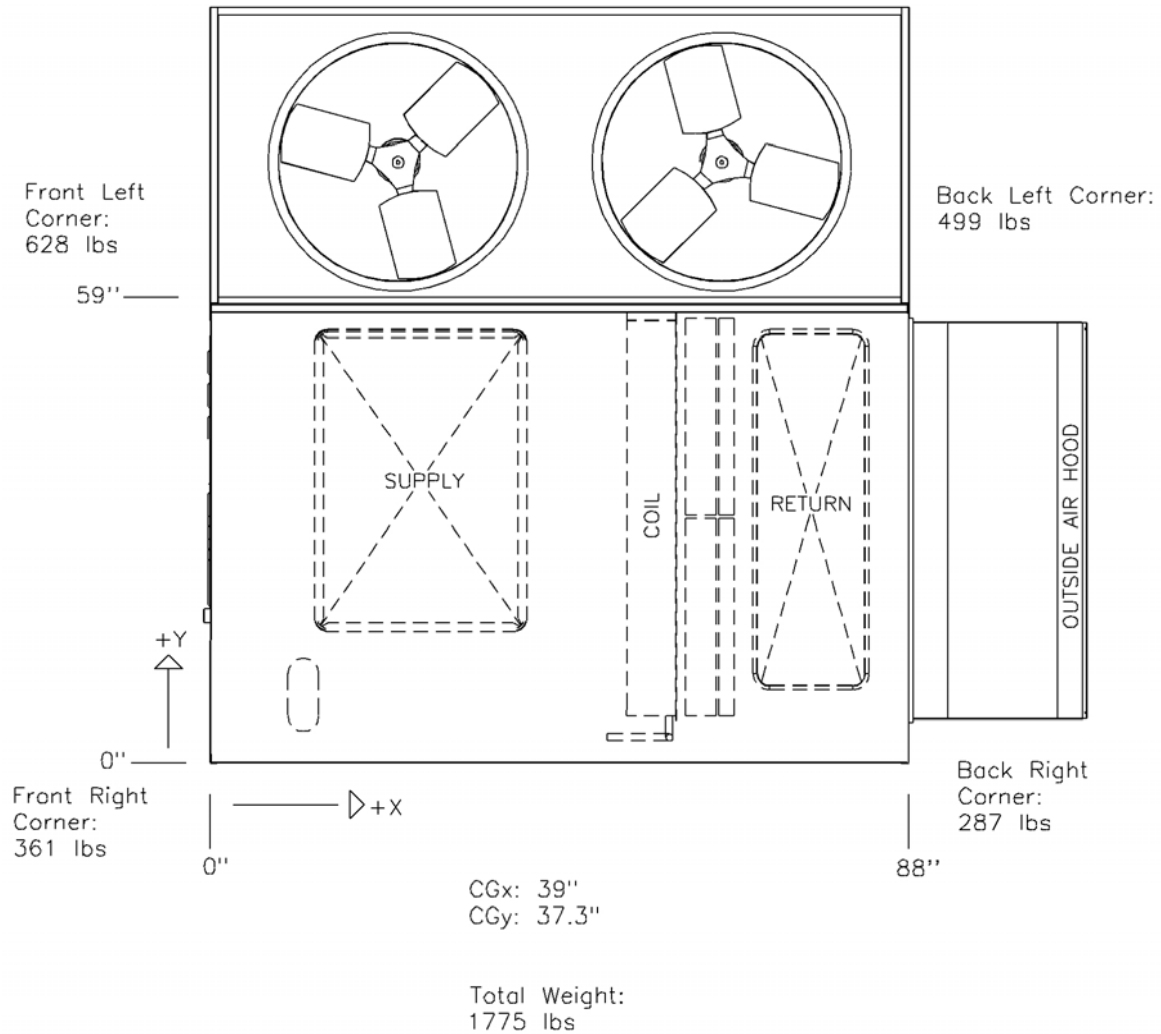

Disclaimer:  
This weight estimate does not account for any SPAs.

RN SERIES  
 B-CABINET SOLID BOTTOM CURB STANDARD AND  
 POWER EXHAUST ~ 9-15 TON

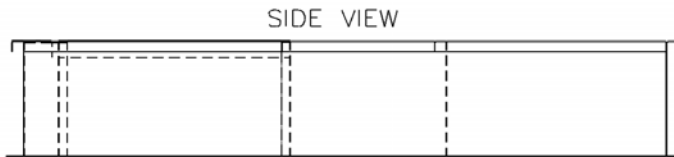
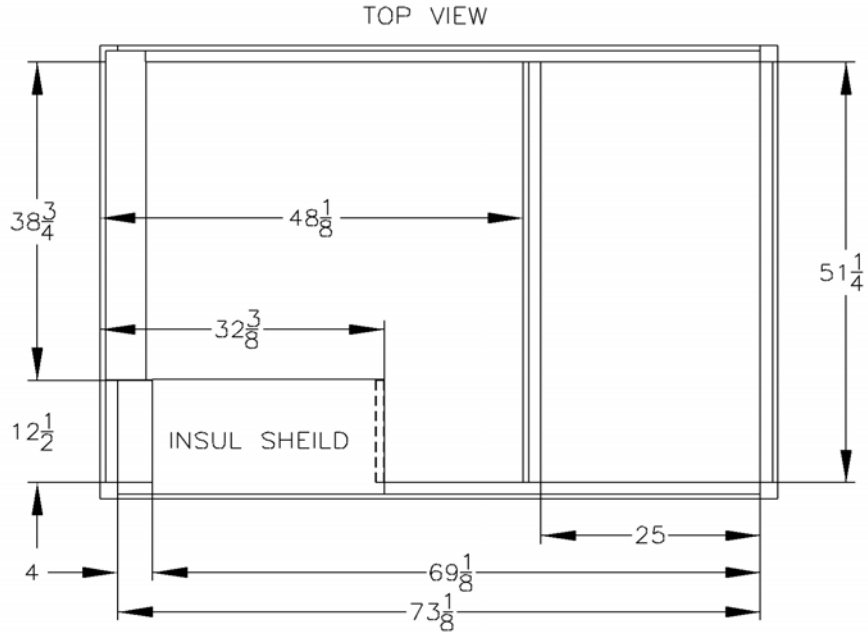

CURB WEIGHTS  
 14IN CURB=140LBS  
 24IN CURB=185LBS

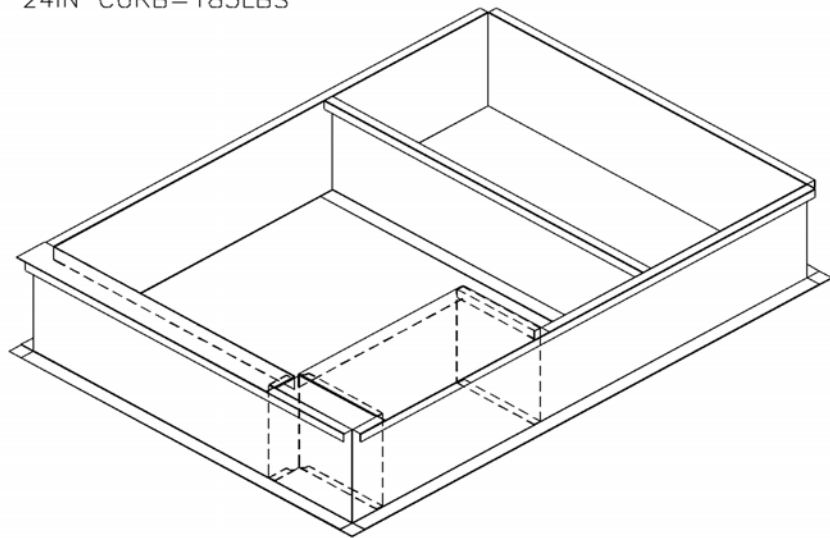
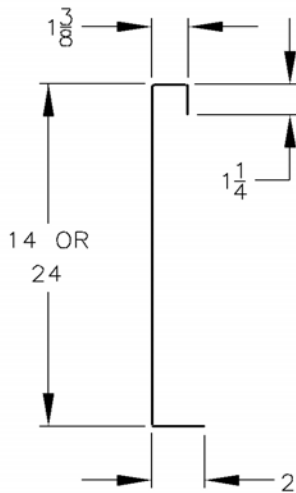

RNB-00050 REV:B 12/14/09 SJS  
 NOTE: ALL DIMENSIONS ARE IN INCHES