



Installation, Start-Up and Service Instructions

CONTENTS

	Page
SAFETY CONSIDERATIONS	1
INSTALLATION	1-29
Step 1 — Provide Unit Support	1
• ROOF CURB	
• ALTERNATE UNIT SUPPORT	
Step 2 — Rig and Place Unit	4
• POSITIONING	
• ROOF MOUNT	
Step 3 — Field Fabricate Ductwork	9
Step 4 — Make Unit Duct Connections	9
Step 5 — Trap Condensate Drain	9
Step 6 — Make Electrical Connections	10
• FIELD POWER SUPPLY	
• FIELD CONTROL WIRING	
• OPTIONAL NON-FUSED DISCONNECT	
• OPTIONAL CONVENIENCE OUTLET	
Step 7 — Make Outdoor-Air Inlet Adjustments	13
• MANUAL OUTDOOR-AIR DAMPER	
Step 8 — Install Outdoor-Air Hood	13
Step 9 — Install All Accessories	14
• MOTORMASTER® I CONTROL INSTALLATION	
• MOTORMASTER V CONTROL INSTALLATION	
Step 10 — Adjust Factory-Installed Options	16
• PREMIERLINK™ CONTROL	
• ENTHALPY SWITCH/RECEIVER	
• OUTDOOR ENTHALPY CONTROL	
• DIFFERENTIAL ENTHALPY CONTROL	
• ENTHALPY SENSORS AND CONTROL	
• OPTIONAL ECONOMISERIV AND ECONOMISER2	
• ECONOMISERIV STANDARD SENSORS	
• ECONOMISERIV CONTROL MODES	
Step 11 — Install Humidistat for Optional MoistureMiSer™ Package	28
START-UP	30-36
SERVICE	37-42
TROUBLESHOOTING	43-45
INDEX	46
START-UP CHECKLIST	CL-1

SAFETY CONSIDERATIONS

Installation and servicing air-conditioning equipment can be hazardous due to system pressure and electrical components. Only trained and qualified service personnel should install, repair, or service air-conditioning equipment.

Untrained personnel can perform basic maintenance functions of cleaning coils and filters and replacing filters. All other operations should be performed by trained service personnel. When working on air-conditioning equipment, observe precautions in the literature, tags and labels attached to the unit, and other safety precautions that may apply.

Follow all safety codes. Wear safety glasses and work gloves. Use quenching cloth for unbrazing operations. Have fire extinguishers available for all brazing operations.

⚠ WARNING

Before performing service or maintenance operations on unit, turn off main power switch to unit. Electrical shock could cause personal injury.

IMPORTANT: Units have high ambient operating limits. If limits are exceeded, the unit will automatically lock the compressor out of operation. Manual reset will be required to restart the compressor.

INSTALLATION

Step 1 — Provide Unit Support

ROOF CURB — Assemble and install accessory roof curb or horizontal adapter roof curb in accordance with instructions shipped with the curb or horizontal adapter. Accessory roof curb and horizontal adapter roof curb and information required to field fabricate a roof curb or horizontal adapter roof curb are shown in Fig. 1A-2. Install insulation, cant strips, roofing, and counter flashing as shown. Ductwork can be secured to roof curb before unit is set in place.

IMPORTANT: The gasketing of the unit to the roof curb or adapter roof curb is critical for a leak-proof seal. Install gasket supplied with the roof curb or adapter roof curb as shown in Fig. 1A and 1B. Improperly applied gasket can result in air leaks and poor unit performance.

ROOFCURB ACCESSORY	CURB HEIGHT	DESCRIPTION
CRRFCURB025A00	1'-2" (356)	ROOF CURB 14" HIGH

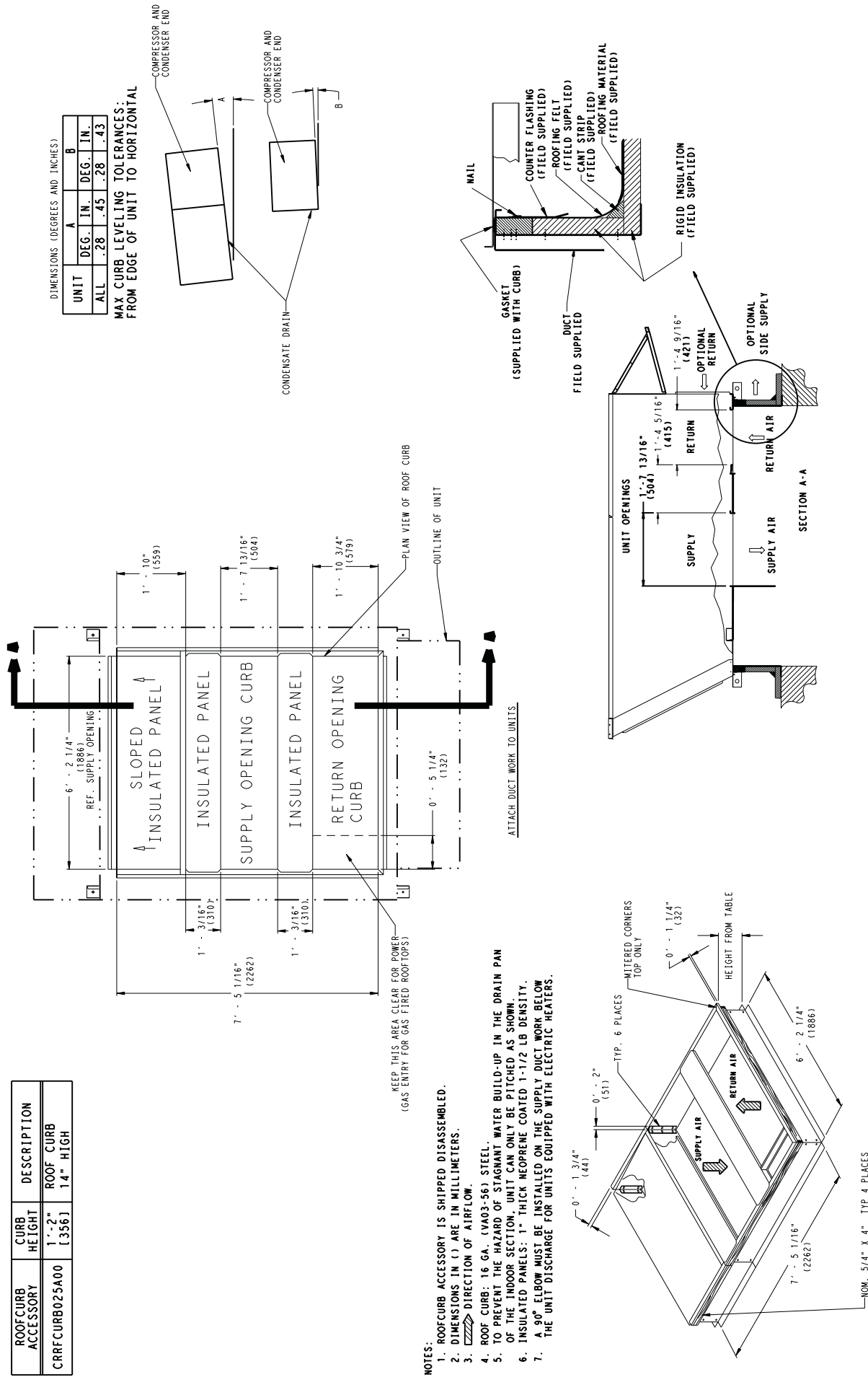
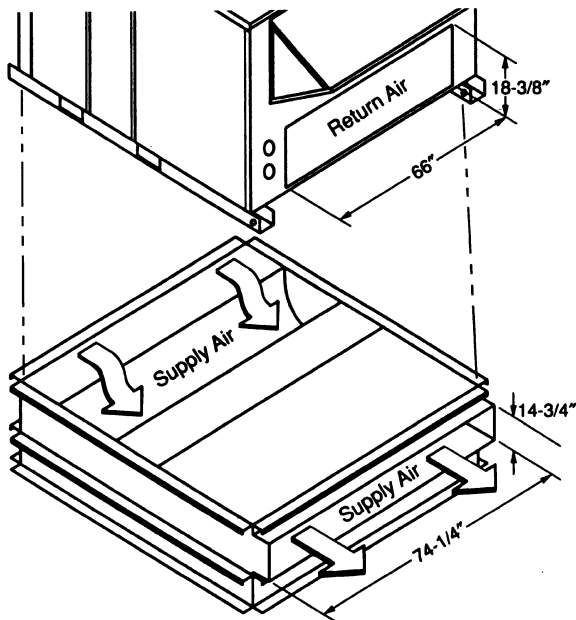
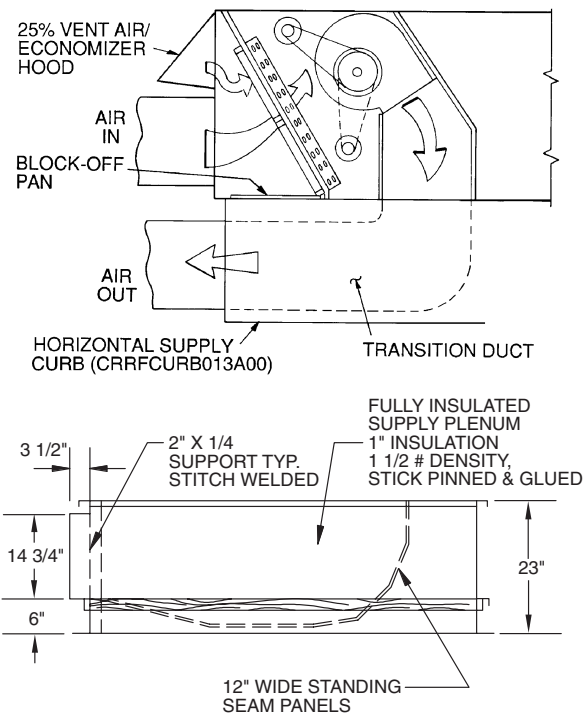

Fig. 1B — Roof Curb Details — 50TM028



NOTE: CRRFCURB013A00 is a fully factory preassembled horizontal adapter and includes an insulated transition duct. The pressure drop through the adapter curb is negligible.

For Horizontal return applications: The power exhaust and barometric relief dampers must be installed in the return air duct.



ACCESSORY PACKAGE NO.	CURB HEIGHT	DESCRIPTION
CRRFCURB013A00	1'-11" (584)	Pre-Assembled Horizontal Adapter Roof Curb

Fig. 2 — Horizontal Supply/Return Adapter Installation (016-025 Only)

Curb or adapter roof curb should be level. This is necessary to permit unit drain to function properly. Unit leveling tolerance is $\pm 1/16$ in. per linear ft in any direction. Refer to Accessory Roof Curb or Horizontal Adapter Roof Curb Installation Instructions for additional information as required.

ALTERNATE UNIT SUPPORT — When the curb or adapter cannot be used, support unit with sleepers using unit curb or adapter support area. If sleepers cannot be used, support long sides of unit with a minimum of 3 equally spaced 4-in. x 4-in. pads on each side.

Step 2 — Rig and Place Unit — Inspect unit for transportation damage. File any claim with transportation agency. Keep unit upright, and do not drop. Use spreader bars over unit to prevent sling or cable damage. Rollers may be used to move unit across a roof. Level by using unit frame as a reference; leveling tolerance is $\pm 1/16$ in. per linear ft in any direction. See Fig. 3 for additional information. Unit weight is shown in Table 1.

Four lifting holes are provided in ends of unit base rails as shown in Fig. 3. Refer to rigging instructions on unit.

POSITIONING — Provide clearance around and above unit for airflow, safety, and service access (Fig. 4-6).

Do not install unit in an indoor location. Do not locate air inlets near exhaust vents or other sources of contaminated air.

Although unit is weatherproof, guard against water from higher level runoff and overhangs.

ROOF MOUNT — Check building codes for weight distribution requirements.

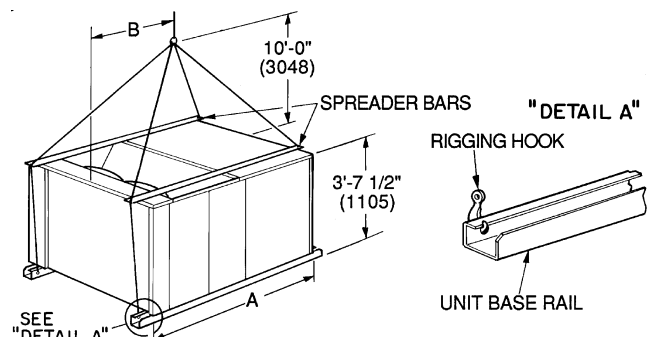

UNIT 50TM	MAXIMUM SHIPPING WEIGHT		DIMENSIONS			
	Lb	Kg	A		B	
			Ft-in.	mm	Ft-in.	mm
016	1725	782	6-11 1/2	2121	4- 0	1219
020	1785	810	6-11 1/2	2121	3-10	1168
025	1905	864	6-11 1/2	2121	3- 7	1092
028	2255	1023	6-11 1/2	2121	3- 5	1041

NOTES:

- Dimensions in () are in millimeters.
- Refer to Fig. 4-6 for unit operating weights.
- Remove boards at ends of unit and runners prior to rigging.
- Rig by inserting hooks into unit base rails as shown. Use corner post from packaging to protect coil from damage. Use bumper boards for spreader bars.
- Weights do not include optional economizer. Add 90 lb (41 kg) for economizer weight. See Table 1 for MoistureMiSer™ dehumidification package weight.
- Weights given are for aluminum evaporator and condenser coil plate fins.

CAUTION
All panels must be in place when rigging.

Fig. 3 — Rigging Details

UNIT	STD. WEIGHT	UNIT WEIGHT	ECONOMIZER CORNER A	CORNER B	CORNER C	CORNER D	DIM A	DIM B	DIM C
50TM016	1650 LB	90 LB	375 LB	375 LB	449 LB	452 LB	3'-2"	3'-7"	1'-10"
	748 KG	41 KG	170 KG	170 KG	204 KG	205 KG	(.963)	(1.092)	(.559)
50TM020	1710 LB	90 LB	410 LB	394 LB	422 LB	459 LB	3'-4"	3'-7"	1'-10"
	776 KG	41 KG	186 KG	179 KG	192 KG	208 KG	(1.016)	(1.092)	(.559)

NOTES:
 1. REFER TO PRINT FOR ROOF CURB ACCESSORY DIMENSIONS.
 2. DIMENSIONS IN () ARE IN MILLIMETERS.
 3. CENTER OF GRAVITY.
 4. DIRECTION OF AIR FLOW.
 5. MINIMUM CLEARANCE TO ACCESSORY ROOF CURB ONLY.
 6. REAR: 7'-0" (2134) FOR COIL REMOVAL. THIS DIMENSION CAN BE REDUCED TO 4'-0" (1219) IF CONDITIONS PERMIT COIL REMOVAL FROM THE TOP.
 7. LEFT SIDE: 4'-0" (1219). FOR PROPER CONDENSER COIL AIR FLOW.
 8. FRONT: 4'-0" (1219). FOR CONTROL BOX ACCESS.
 9. DAMPER POWER EXHAUST FOR OPERATION OF DAMPER.
 10. TOP: 6'-0" (1829). TO ASSURE PROPER CONDENSER FAN OPERATION.
 11. LOCAL CODES OR JURISDICTION MAY PREVAIL.
 12. WITH THE EXCEPTION OF CLEARANCE FOR THE CONDENSER COIL AND THE DAMPER/POWER EXHAUST AS STATED IN NOTE #6, A REMOVABLE FENCE OR BARRICADE REQUIRES NO CLEARANCE.
 13. DIMENSIONS ARE FROM OUTSIDE CORNER TOP EDGE.
 14. ALL ON 0'-5/16" (8) ON EACH SIDE FOR TOP COVER DRIP EDGE.
 15. A 90 DEGREE ELBOW MUST BE INSTALLED ON THE SUPPLY DUCTWORK BELOW THE UNIT DISCHARGE FOR UNITS EQUIPPED WITH ELECTRIC HEATERS

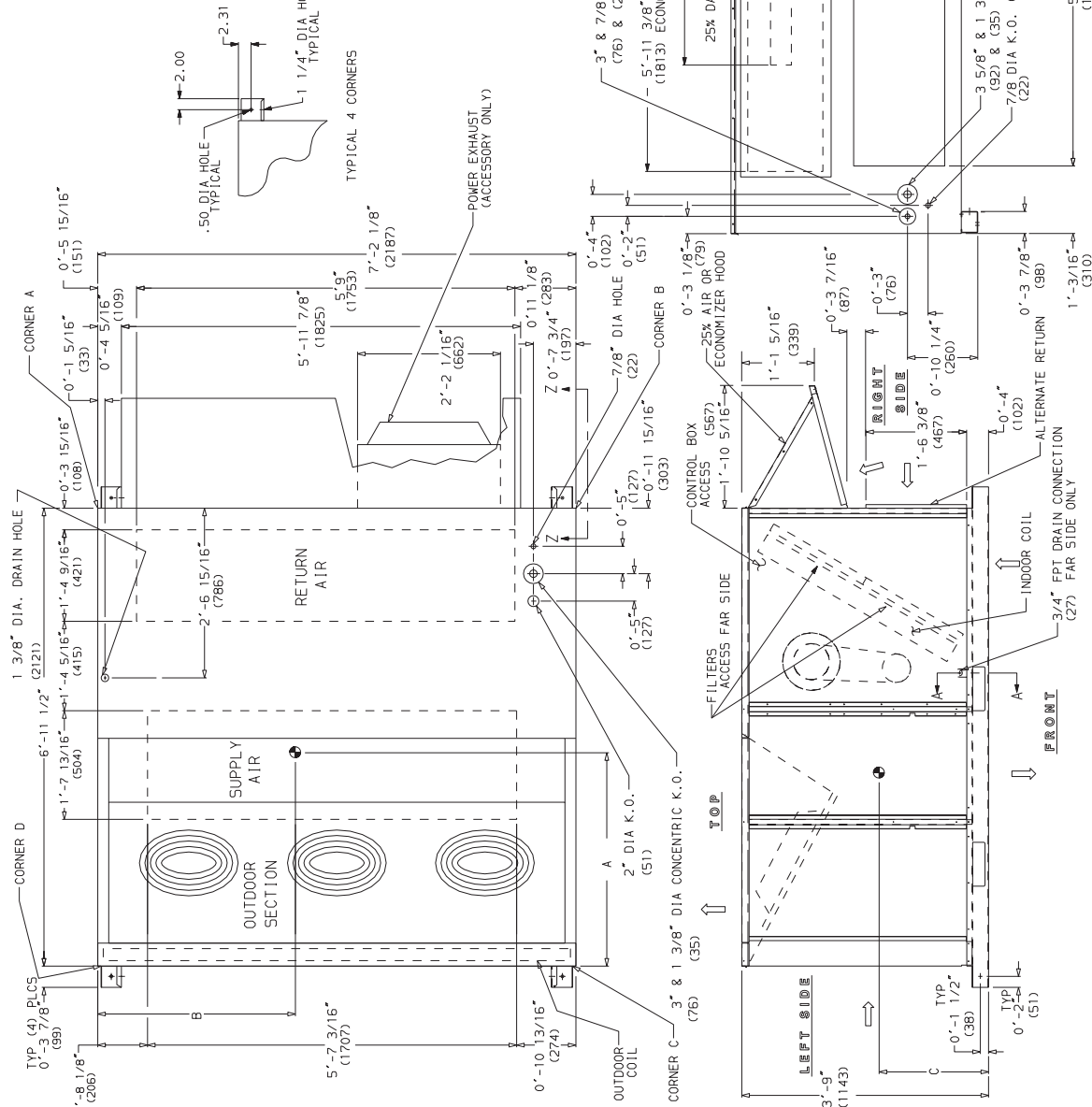

Fig. 4 — Base Unit Dimensions — 50TM016,020

UNIT	STD. WEIGHT	UNIT ECONOMIZER WEIGHT	CORNER A	CORNER B	CORNER C	CORNER D	DIM A	DIM B	DIM C
50TM025	1770 LB 803 KG	90 LB 41 KG	399 LB 181 KG	405 LB 184 KG	475 LB 217 KG	487 LB 221 KG	3'-3" (998)	3'-7" (1092)	1'-8" (508)

- NOTES:
- REFER TO PRINT FOR ROOF CURB ACCESSORY DIMENSIONS.
 - DIMENSIONS IN () ARE IN MILLIMETERS.
 - SEE NOTE #1 FOR GRAVITY FLOW.
 - DUCTWORK TO BE ATTACHED TO ACCESSORY ROOF CURB ONLY.
 - MINIMUM CLEARANCE:

- REAR: 7'-0" (2134) FOR COIL REMOVAL. THIS DIMENSION CAN BE REDUCED TO 4'-0" (1219) IF CONDITIONS PERMIT COIL REMOVAL FROM THE TOP.
- FRONT SIDE: 4'-0" (1219) FOR CONTROL BOX ACCESS.
- RIGHT SIDE: 4'-0" (1219) FOR PROPER OPERATION OF DAMPER AND POWER EXHAUST IF SO EQUIPPED.
- TOP: 6'-0" (1829) TO ASSURE PROPER CONDENSER FAN OPERATION. LOCAL CODES OR JURISDICTION MAY PREVAIL.
- WITH THE EXCEPTION OF CLEARANCE FOR THE CONDENSER COIL REMOVE THE DAMPER/POWER EXHAUST AS STATED IN NOTE #6. A MINIMUM CLEARANCE OF 1'-0" (305) IS REQUIRED.
- DIMENSIONS ARE FROM OUTSIDE OF CORNER POST.
- ALLOW 0'-5/16" (8) ON EACH SIDE FOR TOP COVER DRIP EDGE.
- A 90 DEGREE ELBOW MUST BE INSTALLED ON THE SUPPLY DUCTWORK BELOW THE UNIT DISCHARGE FOR UNITS EQUIPPED WITH ELECTRIC HEATERS.

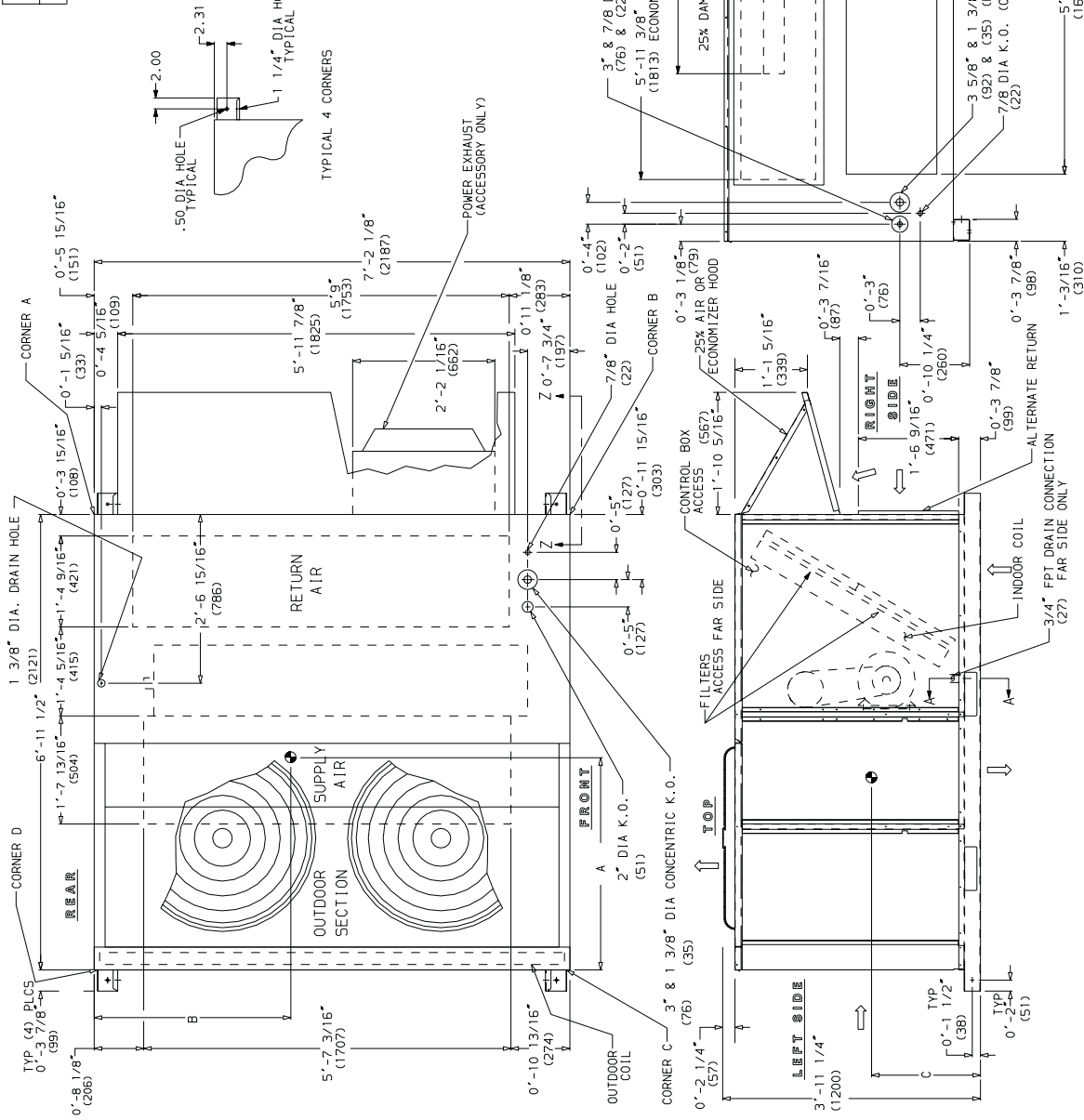
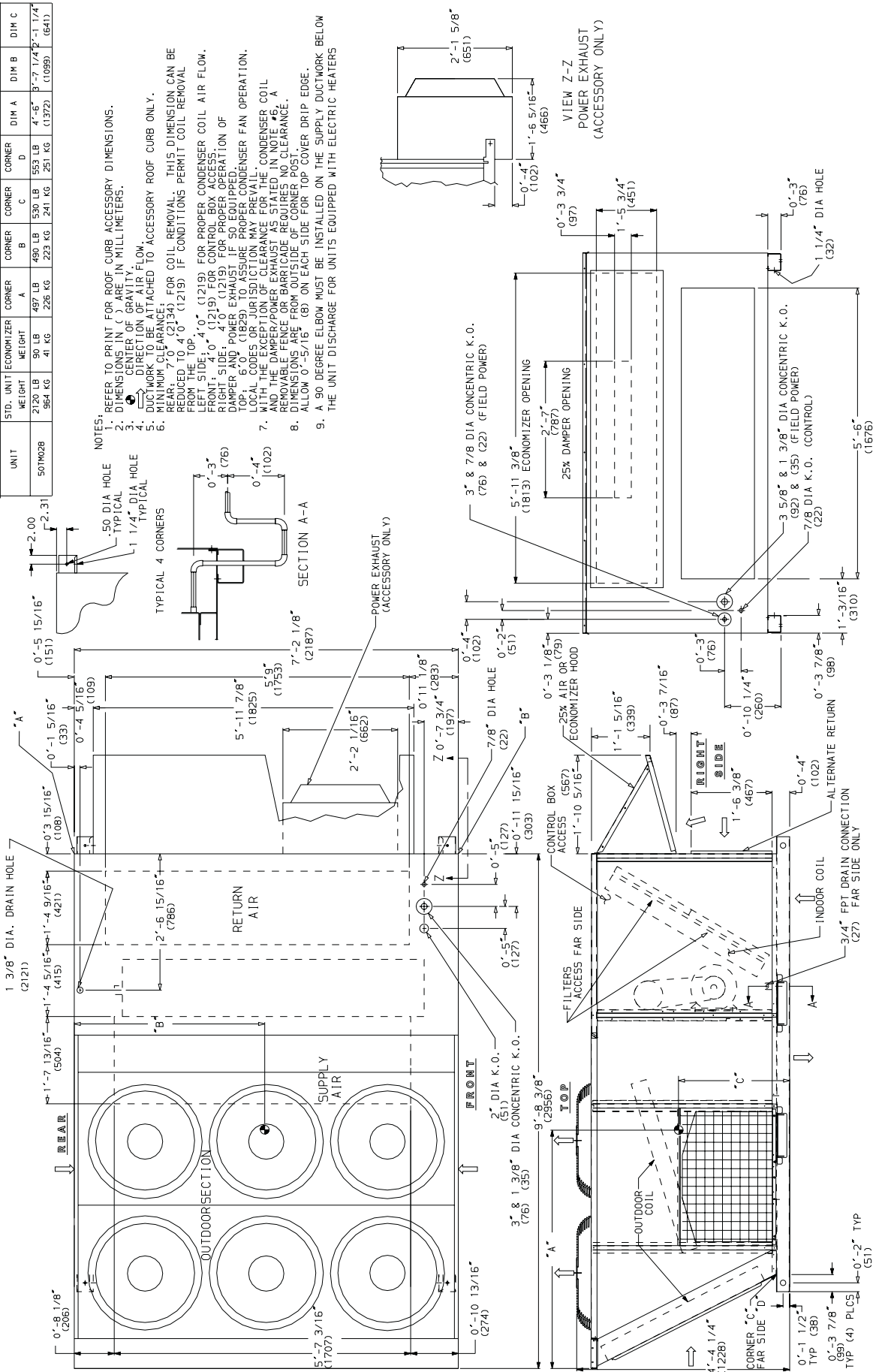

Fig. 5 — Base Unit Dimensions — 50TM025

UNIT	STD. UNIT WEIGHT	ECONOMIZER WEIGHT	CORNER A	CORNER B	CORNER C	CORNER D	DIM A	DIM B	DIM C
50TM028	2120 LB	90 LB	497 LB	490 LB	530 LB	553 LB	4'-6"	3'-7 1/4"	1'-1 1/4"
	954 KG	41 KG	226 KG	223 KG	241 KG	251 KG	1.3722	1.0999	0.6417



NOTES:
 1. REFER TO PRINT FOR ROOF CURB ACCESSORY DIMENSIONS.
 2. DIMENSIONS ARE IN MILLIMETERS.
 3. DIRECTION OF GRAVITY.
 4. DIRECTION OF AIR FLOW.
 5. DUCTWORK TO BE ATTACHED TO ACCESSORY ROOF CURB ONLY.
 6. MINIMUM CLEARANCE:
 REAR: 7'-0" (2134) FOR COIL REMOVAL.
 LEFT SIDE: 10'-4" (3151) IF CONDITIONS PERMIT COIL REMOVAL.
 FRONT: 4'-0" (1219) FOR PROPER CONDENSER COIL AIR FLOW.
 RIGHT SIDE: 4'-0" (1219) FOR PROPER OPERATION OF DAMPER AND POWER EXHAUST IF SO EQUIPPED.
 TOP: 6'-0" (1829) TO ASSURE PROPER CONDENSER FAN OPERATION.
 LOCAL COILS OR JURISDICTION MAY PREVAIL.
 7. AND THE DAMPER/POWER EXHAUST STATES IN NOTE C, A REMOVABLE FENCE OR BARRICADE REQUIRES NO CLEARANCE.
 8. DIMENSIONS ARE FROM OUTSIDE OF CORNER POST.
 9. ALLOW 0'-5/16" (8) ON EACH SIDE FOR TOP COVER DRIP EDGE.
 9. A 90 DEGREE ELBOW MUST BE INSTALLED ON THE SUPPLY DUCTWORK BELOW THE UNIT DISCHARGE FOR UNITS EQUIPPED WITH ELECTRIC HEATERS

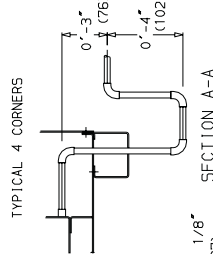

Fig. 6 — Base Unit Dimensions — 50TM028

Table 1 — Physical Data

UNIT 50TM	016	020	025	028
NOMINAL CAPACITY (tons)	15	18	20	25
OPERATING WEIGHT (lb)	1650	1710	1770	2120
Economizer	90	90	90	90
MoistureMiSer™ Dehumidification Package	40	40	40	40
COMPRESSOR/MANUFACTURER	Scroll, Copeland			
Quantity...Model (Ckt 1, Ckt 2)	1...ZR94KC, 1...ZR72KC	1...ZR108KC, 1...ZR94KC	1...ZR125KC, 1...ZR108KC	1...ZR140KC,* 1...ZR144KC
Capacity Stages (%)	60, 40	55, 45	55, 45	50, 50
Number of Refrigerant Circuits	2	2	2	2
Oil (oz) (Ckt 1, Ckt 2)	85, 60	106, 81	106, 106	136, 106
REFRIGERANT TYPE	R-22			
Expansion Device	TXV			
Operating Charge (lb-oz)	19-8	19-8	19-11	26-13
Circuit 1†	13-8	19-2	13-14	25-10
Circuit 2				
CONDENSER COIL	Cross-Hatched 3/8-in. Copper Tubes, Aluminum Lanced, Aluminum Pre-Coated, or Copper Plate Fins			
Rows...Fins/in.	4...15	4...15	4...15	3...15 (2 coils)
Total Face Area (sq ft)	21.7	21.7	21.7	43.4
CONDENSER FAN	Propeller Type			
Nominal Cfm	10,500	10,500	14,200	21,000
Quantity...Diameter (in.)	3...22	3...22	2...30	6...22
Motor Hp...Rpm	1/2...1050	1/2...1050	1...1075	1/2...1050
Watts Input (Total)	1100	1100	3400	2200
EVAPORATOR COIL	Cross-Hatched 3/8-in. Copper Tubes, Aluminum Lanced or Copper Plate Fins, Face Split			
Rows...Fins/in.	4...15	4...15	4...15	4...15
Total Face Area (sq ft)	17.5	17.5	17.5	17.5
EVAPORATOR FAN	Centrifugal Type			
Quantity...Size (in.)	2...12 x 12	2...12 x 12	2...12 x 12	2...12 x 12
Type Drive	Belt	Belt	Belt	Belt
Nominal Cfm	6000	7200	8000	10,000
Motor Hp	5	5	7.5	10
Motor Nominal Rpm	1745	1745	1745	1740
Maximum Continuous Bhp	6.13	5.90	8.7 [208/230, 575 v] 9.5 [460 v]	10.2 [208/230, 575 v] 11.8 [460 v]
Motor Frame Size	184T	184T	213T	215T
Nominal Rpm High/Low	—	—	—	—
Fan Rpm Range	873-1021 1025-1200	910-1095 1069-1287	1002-1151 1193-1369	1066-1283 1332-1550
Motor Bearing Type	Ball	Ball	Ball	Ball
Maximum Allowable Rpm	1550	1550	1550	1550
Motor Pulley Pitch Diameter	4.9/5.9	4.9/5.9	5.4/6.6	4.9/5.9
Min/Max (in.)	4.9/5.9	4.9/5.9	5.4/6.6	4.9/5.9
Nominal Motor Shaft Diameter (in.)	1 1/8	1 1/8	1 3/8	1 3/8
Fan Pulley Pitch Diameter (in.)	9.4	9.4	9.4	8.0
Nominal Fan Shaft Diameter (in.)	8.0	8.0	7.9	6.4
Belt, Quantity...Type...Length (in.)	17/16	17/16	17/16	17/16
Pulley Center Line Distance (in.)	1...BX...50	1...BX...50	1...BX...53	2...BX...50
Speed Change per Full Turn of Movable Pulley Flange (rpm)	1...BX...48	1...BX...48	1...BX...50	2...BX...47
Movable Pulley Maximum Full Turns From Closed Position	13.3-14.8	13.3-14.8	14.6-15.4	14.6-15.4
Factory Speed	37	37	37	36
Factory Speed Setting (rpm)	44	34	44	45
Fan Shaft Diameter at Pulley (in.)	6**	6††	6**	6††
Factory Speed	3.5	3.5	3.5	3.5
Factory Speed Setting (rpm)	965	1002	1095	1182
Fan Shaft Diameter at Pulley (in.)	1134	1178	1303	1470
Factory Speed Setting (rpm)	17/16	17/16	17/16	17/16
HIGH-PRESSURE SWITCH (psig)				
Cutout	426			
Reset (Auto)	320			
LOW-PRESSURE SWITCH (psig)				
Cutout	27			
Reset (Auto)	44			
FREEZE PROTECTION THERMOSTAT (F)				
Opens	30 ± 5			
Closes	45 ± 5			
OUTDOOR-AIR INLET SCREENS	Cleanable			
Quantity...Size (in.)	2...20 x 25 x 1 1...20 x 20 x 1			
RETURN-AIR FILTERS	Throwaway***			
Quantity...Size (in.)	4...20 x 20 x 2 4...16 x 20 x 2			
POWER EXHAUST	1/2 Hp, 208/230-460 v Motor Direct Drive, Propeller-Fan (Factory-Wired for 460 v)			

LEGEND

Bhp — Brake Horsepower
TXV — Thermostatic Expansion Valve

*The ZRU140KC compressor is a tandem compressor, consisting of a ZR72KC (25% total capacity) and a ZR68KC (24% total capacity).
 †Circuit 1 uses the lower portion of the condenser coil and lower portion of the evaporator coils; and Circuit 2 uses the upper portion of both coils.

**Pulley has 6 turns. Due to belt and pulley size, movable pulley cannot be set to 0 to 1 1/2 turns open.

††Pulley has 6 turns. Due to belt and pulley size, movable pulley cannot be set to 0 to 1/2 turns open.

***The 50TM028 unit requires 2-in. industrial-grade filters capable of handling face velocities up to 625 ft/min (such as American Air Filter no. 5700 or equivalent).

NOTE: The 50TM016-028 units have a low-pressure switch (standard) located on the suction side.

Step 3 — Field Fabricate Ductwork — Secure all ducts to building structure. Use flexible duct connectors between unit and ducts as required. Insulate and weatherproof all external ductwork, joints, and roof openings with counter flashing and mastic in accordance with applicable codes.

Ducts passing through an unconditioned space must be insulated and covered with a vapor barrier.

The 50TM units with electric heat require a 1-in. clearance for the first 24 in. of ductwork.

Outlet grilles must not lie directly below unit discharge.

NOTE: A 90-degree elbow must be provided in the ductwork to comply with UL (Underwriters Laboratories) codes for use with electric heat.

⚠ WARNING

For vertical supply and return units, tools or parts could drop into ductwork and cause an injury. Install a 90-degree turn in the return ductwork between the unit and the conditioned space. If a 90-degree elbow cannot be installed, then a grille of sufficient strength and density should be installed to prevent objects from falling into the conditioned space. Due to electric heater, supply duct will require 90-degree elbow.

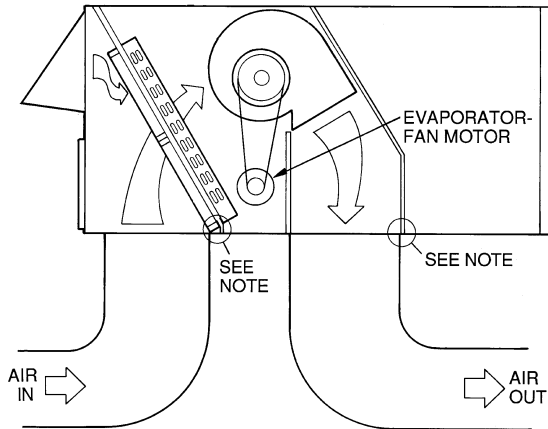

NOTE: Do not drill in this area; damage to basepan may result in water leak.

Fig. 7 — Air Distribution — Thru-the-Bottom

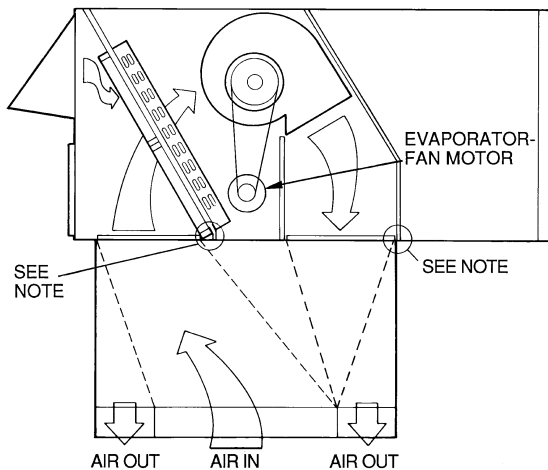

NOTE: Do not drill in this area; damage to basepan may result in water leak.

Fig. 8 — Concentric Duct Air Distribution

Step 4 — Make Unit Duct Connections — Unit is shipped for through-the-bottom duct connections. Ductwork openings are shown in Fig. 7. Field-fabricated concentric ductwork may be connected as shown in Fig. 8 and 9. Attach all ductwork to roof curb and roof curb basepans. Refer to installation instructions shipped with accessory roof curb for more information.

Step 5 — Trap Condensate Drain — See Fig. 4-6 and 10 for drain location. Plug is provided in drain hole and must be removed when unit is operating. One 3/4-in. half-coupling is provided inside unit evaporator section for condensate drain connection. An 8 1/2 in. x 3/4-in. diameter nipple and a 2-in. x 3/4-in. diameter pipe nipple are coupled to standard 3/4-in. diameter elbows to provide a straight path down through holes in unit base rails (see Fig. 11). A trap at least 4-in. deep must be used.

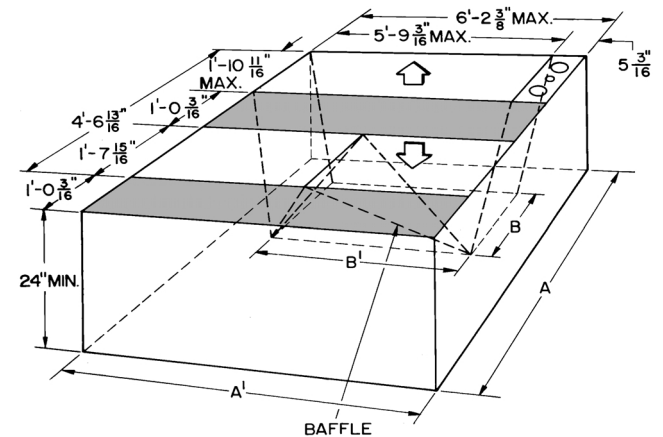

Shaded area indicates block-off panels.

NOTE: Dimensions A, A', and B, B' are obtained from field-supplied ceiling diffuser.

Fig. 9 — Concentric Duct Details

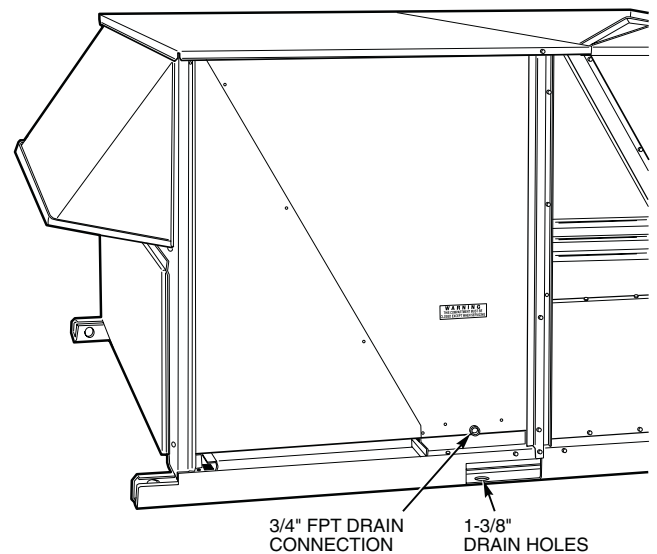

Fig. 10 — Condensate Drain Details (50TM016,020 Shown)

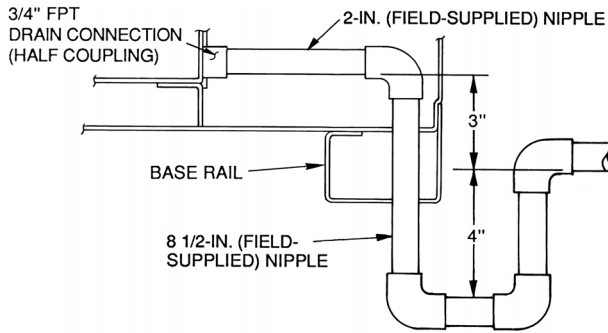

Fig. 11 — Condensate Drain Piping Details

Step 6 — Make Electrical Connections

FIELD POWER SUPPLY — Unit is factory wired for voltage shown on nameplate.

When installing units, provide a disconnect, per NEC (National Electrical Code) requirements, of adequate size (Table 2).

All field wiring must comply with NEC and local requirements.

Route power lines through control box access panel or unit basepan (Fig. 4-6) to connections as shown on unit wiring diagram and Fig. 12.

Operating voltage to compressor must be within voltage range indicated on unit nameplate. On 3-phase units, voltages between phases must be balanced within 2% and the current must be balanced within 10%.

⚠ CAUTION

The correct power phasing is critical in the operation of the scroll compressors. An incorrect phasing will cause the compressor to rotate in the wrong direction. This may lead to premature compressor failure.

Use the following formula to determine the percentage of voltage imbalance.

Percentage of Voltage Imbalance

$$= 100 \times \frac{\text{max voltage deviation from average voltage}}{\text{average voltage}}$$

EXAMPLE: Supply voltage is 460-3-60.

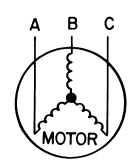

AB = 452 v
BC = 464 v
AC = 455 v

$$\text{Average Voltage} = \frac{455 + 464 + 455}{3}$$

$$= \frac{1371}{3}$$

$$= 457$$

Determine maximum deviation from average voltage:

$$(AB) 457 - 452 = 5 \text{ v}$$

$$(BC) 464 - 457 = 7 \text{ v}$$

$$(AC) 457 - 455 = 2 \text{ v}$$

Maximum deviation is 7 v.

Determine percent voltage imbalance:

$$\text{Percentage of Voltage Imbalance} = 100 \times \frac{7}{457}$$

$$= 1.53\%$$

This amount of phase imbalance is satisfactory as it is below the maximum allowable 2%.

IMPORTANT: If the supply voltage phase imbalance is more than 2%, contact your local electric utility company immediately.

Unit failure as a result of operation on improper line voltage or excessive phase imbalance constitutes abuse and may cause damage to electrical components.

FIELD CONTROL WIRING — Install a Carrier-approved accessory thermostat assembly according to the installation instructions included with the accessory. Locate thermostat assembly on a solid wall in the conditioned space to sense average temperature.

Route thermostat cable or equivalent single leads of no. 18 AWG (American Wire Gauge) colored wire from subbase terminals through conduit in unit to low-voltage connections as shown on unit label wiring diagram and in Fig. 13.

NOTE: For wire runs up to 50 ft, use no. 18 AWG insulated wire (35 C minimum). For 50 to 75 ft, use no. 16 AWG insulated wire (35 C minimum). For over 75 ft, use no. 14 AWG insulated wire (35 C minimum). All wire larger than no. 18 AWG cannot be directly connected to the thermostat and will require a junction box and splice at the thermostat.

Set heat anticipator settings as indicated in Table 3. Settings may be changed slightly to provide a greater degree of comfort for a particular installation.

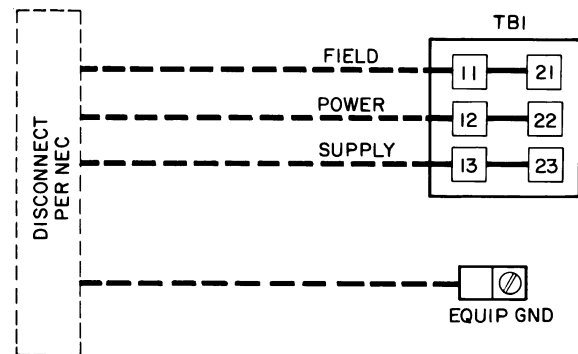

TB1 MAXIMUM WIRE SIZE

UNIT 50TM	VOLTAGE		
	208/230	460	575
All	350 kcmil	2/0	2/0

- LEGEND
- EQUIP — Equipment
 - GND — Ground
 - kcmil — Thousand Circular Mills
 - NEC — National Electrical Code
 - TB — Terminal Block

Fig. 12 — Field Power Wiring Connections

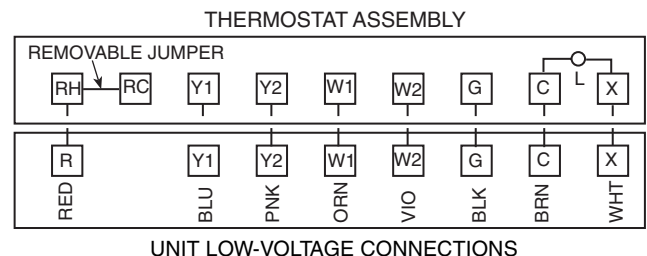

Fig. 13 — Field Control Thermostat Wiring

Table 2 — Electrical Data

UNIT 50TM	NOMINAL VOLTAGE (3 Ph, 60 Hz)	VOLTAGE RANGE		COMPRESSOR						OFM			IFM		POWER EXHAUST		ELECTRIC HEAT*		POWER SUPPLY	
				No. 1		No. 1A		No. 2												
		Min	Max	RLA	LRA	RLA	LRA	RLA	LRA	Qty	Hp	FLA (ea)	Hp	FLA	FLA	LRA	kW	FLA	MCA	MOCP†
016	208/230	187	253	32.1	195	—	—	20.7	156	3	0.5	1.7	5.0	15.8/15.8	—	—	—	—	82/ 82	110/110
															4.6	18.8	—	—	86/ 86	110/110
															—	—	26/34	71/ 82	109/122	110/125
															4.6	18.8	26/34	71/ 82	114/128	125/150
	460	414	508	16.4	95	—	—	10	70	3	0.5	0.8	5.0	7.9	—	—	—	—	41	50
															2.3	6.0	—	—	43	50
															—	—	32	39	59	60
															2.3	6.0	32	39	62	70
	575	518	633	12	80	—	—	8.2	54	3	0.5	0.75	5.0	6.0	—	—	—	—	31	40
															2.1	4.8	—	—	34	40
															—	—	55	66	76	90
															2.3	6.0	55	66	79	90
020	208/230	187	253	30.1	225	—	—	28.8	195	3	0.5	1.7	5.0	15.8/15.8	—	—	—	—	87/ 87	110/110
															4.6	18.8	—	—	92/ 92	110/110
															—	—	26/34	71/ 82	109/122	110/125
															4.6	18.8	26/34	71/ 82	114/128	125/150
	460	414	508	15.5	114	—	—	14.7	95	3	0.5	0.8	5.0	7.9	—	—	—	—	44	50
															2.3	6.0	—	—	47	60
															—	—	32	39	59	60
															2.3	6.0	32	39	61	70
	575	518	632.5	12.1	80	—	—	10.8	80	3	0.5	0.8	5.0	6.0	—	—	—	—	34	40
															2.1	4.8	—	—	36	40
															—	—	55	66	76	90
															2.3	6.0	55	66	79	90
025	208/230	187	253	42	239	—	—	33.6	225	2	1	6.6	7.5	25.0/25.0	—	—	—	—	124/124	150/150
															4.6	18.8	—	—	129/129	150/150
															—	—	26/34	71/ 82	124/134	150/150
															4.6	18.8	26/34	71/ 82	129/140	150/150
	460	414	508	19.2	125	—	—	17.3	114	2	1	3.3	7.5	13.0	—	—	—	—	61	80
															2.3	6	—	—	63	80
															—	—	42/56	117/135	178/166	200/175
															2.3	6	42/56	117/135	183/172	200/175
	575	518	632.5	13.8	80	—	—	13.5	80	2	1.0	3.4	7.5	10.0	—	—	—	—	187/211	200/225
															2.1	4.8	—	—	193/217	200/225
															—	—	56/75	156/180	187/211	200/225
															2.3	6	56/75	156/180	193/217	200/225

Table continued on next page.

Table 2 — Electrical Data (cont)

UNIT 50TM	NOMINAL VOLTAGE (3 Ph, 60 Hz)	VOLTAGE RANGE		COMPRESSOR						OFM			IFM		POWER EXHAUST		ELECTRIC HEAT*		POWER SUPPLY	
				No. 1		No. 1A		No. 2												
		Min	Max	RLA	LRA	RLA	LRA	RLA	LRA	Qty	Hp	FLA (ea)	Hp	FLA	FLA	LRA	kW	FLA	MCA	MOCP†
028	208/230	187	253	20.7	156	20.7	156	47.1	245	6	0.5	1.7	10.0	28.0/28.0	—	—	—	—	138/138	175/175
															4.6	18.8	—	—	143/143	175/175
															—	—	26/34	71/ 82	138/138	175/175
															4.6	18.8	26/34	71/ 82	143/143	175/175
															—	—	42/56	117/135	181/170	200/175
															4.6	18.8	42/56	117/135	187/176	200/200
	460	414	508	10.0	75	10.0	75	19.6	125	6	0.5	0.8	10.0	14.6	—	—	—	—	64	80
															2.3	6	—	—	66	80
															—	—	32	39	67	80
															2.3	6	32	39	70	80
															—	—	55	66	84	90
															2.3	6	55	66	87	100
575	518	622.5	16.4	108	8.2	54	15.8	100	6	0.5	0.8	10.0	13.0	—	—	—	—	54	60	
														2.1	4.8	—	—	56	70	

LEGEND

- FLA** — Full Load Amps
- HACR** — Heating, Air Conditioning and Refrigeration
- IFM** — Indoor (Evaporator) Fan Motor
- LRA** — Locked Rotor Amps
- MCA** — Minimum Circuit Amps
- MOCP** — Maximum Overcurrent Protection
- NEC** — National Electrical Code
- OFM** — Outdoor (Condenser) Fan Motor
- RLA** — Rated Load Amps

*Heater capacity (kW) is based on heater voltage of 208 v, 240 v and 480 v. Heaters are rated at 240 v and 480 v. If power distribution voltage to unit varies from rated heater voltage, heater kW will vary accordingly. To determine heater capacity at actual unit voltage, multiply 240 v or 480 v capacity by multipliers found in table in Note 4.

†Fuse or HACR circuit breaker.

**Electric heaters are field installed.

NOTES:

1. In compliance with NEC requirements for multimotor and combination load equipment (refer to NEC Articles 430 and 440), the overcurrent protective device for the unit shall be fuse or HACR breaker. The Canadian units may be fuse or circuit breaker.

2. Unbalanced 3-Phase Supply Voltage

Never operate a motor where a phase imbalance in supply voltage is greater than 2%. Use the following formula to determine the percent of voltage imbalance.

% Voltage Imbalance
= 100 x $\frac{\text{max voltage deviation from average voltage}}{\text{average voltage}}$

EXAMPLE: Supply voltage is 460-3-60.

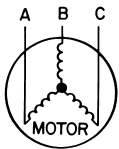

AB = 452 v
BC = 464 v
AC = 455 v

Average Voltage = $\frac{452 + 464 + 455}{3}$
= $\frac{1371}{3}$
= 457

Determine maximum deviation from average voltage.

(AB) 457 - 452 = 5 v

(BC) 464 - 457 = 7 v

(AC) 457 - 455 = 2 v

Maximum deviation is 7 v.

Determine percent voltage imbalance.

% Voltage Imbalance = $100 \times \frac{7}{457}$
= 1.53%

This amount of phase imbalance is satisfactory as it is below the maximum allowable 2%.

IMPORTANT: If the supply voltage phase imbalance is more than 2%, contact your local electric utility company immediately.

3. MCA calculation for 50TM016-028 units with electric heaters over 50 kW = (1.25 x IFM amps) + (1.00 x heater FLA).
4. Use the following table to determine heater capacity at actual voltage.

HEATER RATING VOLTAGE	ACTUAL HEATER VOLTAGE							
	200	208	230	240	380	440	460	480
240	0.694	0.751	0.918	1.000	—	—	—	—
480	—	—	—	—	0.626	0.840	0.918	1.000

EXAMPLE: 34 kW (at 230 v) heater on 208 v
= 34.0 (.751 mult factor)
= 25.5 kW capacity at 208 v.



Table 3 — Heat Anticipator Settings

UNIT 50TM	UNIT VOLTAGES	kW*	STAGE 1	STAGE 2
016-028	208/230-3-60	26/34	.40	.66
		42/56	.66	.40
		56/75	.66	.66
	460-3-60	32	.40	.40
		55	.40	.66
		80	.66	.66

*Heater kW is based on heater voltage of 208 v, 240 v or 480 v.

OPTIONAL NON-FUSED DISCONNECT — On units with the optional non-fused disconnect, incoming power will be wired into the disconnect switch. Refer to Fig. 14 for wiring for 100 and 200 amp disconnect switches. Units with an MOCP under 100 will use the 100 amp disconnect switch. Units with an MOCP over 100 will use the 200 amp disconnect switch. Refer to the applicable disconnect wiring diagram.

To prevent breakage during shipping, the disconnect handle and shaft are shipped and packaged inside the unit control box. Install the disconnect handle before unit operation. To install the handle and shaft, perform the following procedure:

1. Open the control box door and remove the handle and shaft from shipping location.
2. Loosen the Allen bolt located on the disconnect switch. The bolt is located on the square hole and is used to hold the shaft in place. The shaft cannot be inserted until the Allen bolt is moved.
3. Insert the disconnect shaft into the square hole on the disconnect switch. The end of the shaft is specially cut and the shaft can only be inserted in the correct orientation.
4. Tighten the Allen bolt to lock the shaft into position.
5. Close the control box door.
6. Attach the handle to the external access door with the two screws provided. When the handle is in the ON position, the handle will be vertical. When the handle is in the OFF position, the handle will be horizontal.
7. Turn the handle to the OFF position and close the door. The handle should fit over the end of the shaft when the door is closed.
8. The handle must be in the OFF position to open the control box door.

OPTIONAL CONVENIENCE OUTLET — On units with optional convenience outlet, a 115-v GFI (ground fault interrupt) convenience outlet receptacle is provided for field wiring. Field wiring should be run through the 7/8-in. knockout provided in the basepan near the return air opening.

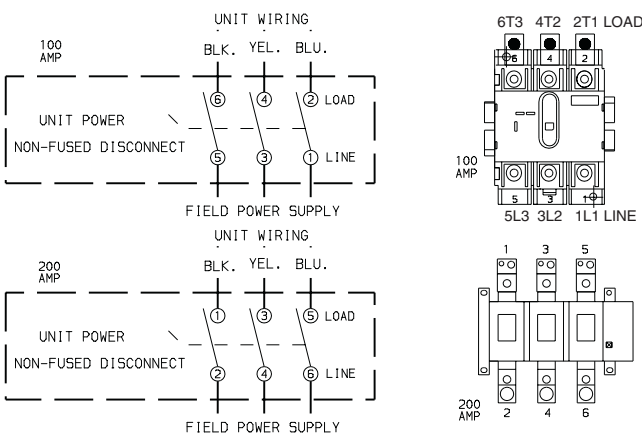

NOTE: The disconnect takes the place of TB-1 as shown on the unit wiring diagram label and the component arrangement label.

Fig. 14 — Optional Non-Fused Disconnect Wiring

Step 7 — Make Outdoor-Air Inlet Adjustments

MANUAL OUTDOOR-AIR DAMPER — All units (except those equipped with a factory-installed economizer) have a manual outdoor-air damper to provide ventilation air. Damper can be preset to admit up to 25% outdoor air into return-air compartment. To adjust, loosen securing screws and move damper to desired setting. Then retighten screws to secure damper (Fig. 15).

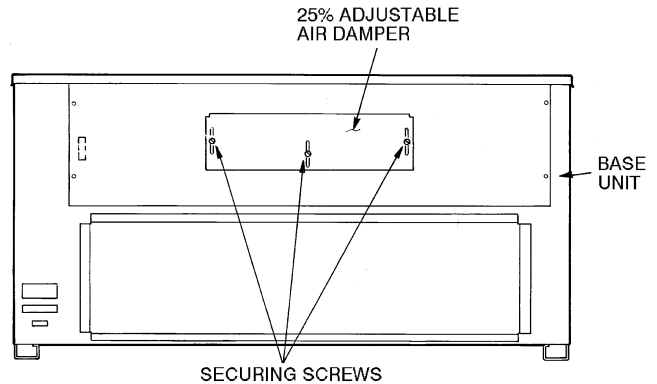

Fig. 15 — 25% Outdoor-Air Section Details

Step 8 — Install Outdoor-Air Hood — The same type of factory-installed hood is used on units with 25% air ventilation and units with an economizer.

IMPORTANT: If the unit is equipped with the optional EconoMiSerIV component, move the outdoor-air temperature sensor prior to installing the outdoor-air hood. See the Optional EconoMiSerIV and EconoMiSer2 section for more information.

⚠ WARNING

Personal Injury Hazard. Avoid possible injury by keeping fingers away from damper blades.

NOTE: The hood top panel, upper and lower filter retainers, hood drain pan, baffle (028), and filter support bracket are secured to the unit and shipping skid at the opposite end of the unit in front of the condenser coil. The screens, hood side panels, remaining section of filter support bracket, seal strip, and all other hardware are in a package located inside the return-air filter access panel (Fig. 16).

1. Attach seal strip to upper filter retainer. See Fig. 17.
2. Assemble hood top panel and side panels, upper filter retainer, and hood drain pan (Fig. 18).
3. Secure lower filter retainer and long section of filter support bracket to unit. See Fig. 18. Leave screws loose on 028 units.
4. Slide baffle (size 028 unit) behind lower filter retainer and tighten screws.
5. Loosen sheet metal screws for base unit top panel located above outdoor-air inlet opening, and remove screws for hood side panels located on the sides of the outdoor-air inlet opening.
6. Match notches in hood top panel to unit top panel screws. Insert hood flange between unit top panel flange and unit. Tighten screws.
7. Hold hood side panel flanges flat against unit, and install screws removed in Step 5.
8. Insert outdoor-air inlet screens and spacer in channel created by lower filter retainer and filter support bracket.
9. Attach remaining short section of filter support bracket.

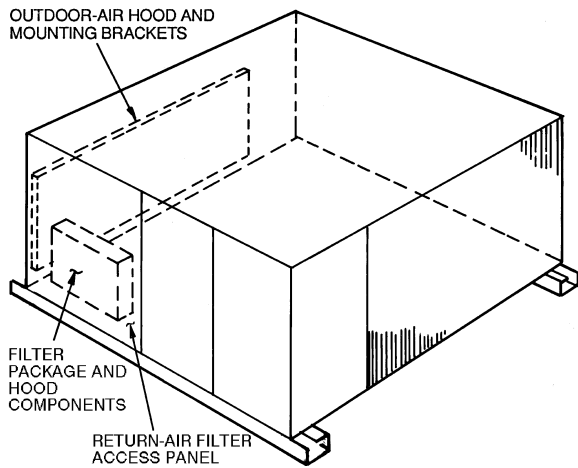
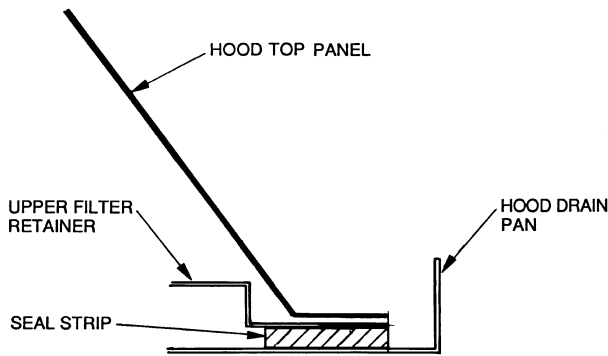
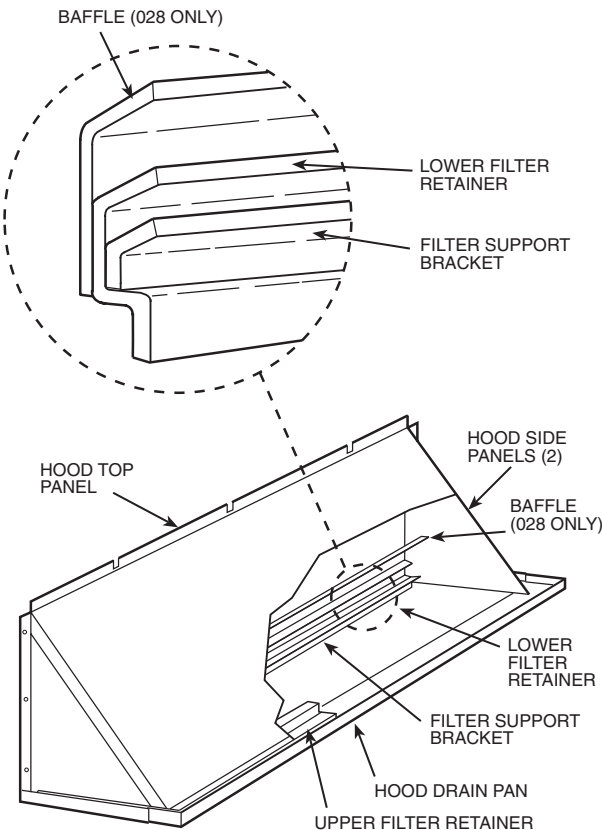

Fig. 16 — Outdoor-Air Hood Component Location



**Fig. 17 — Seal Strip Location
(Air Hood Cross-Sectional View)**



NOTE: The outdoor-air hood comes with a baffle which is used on 028 units only; discard baffle for 016-025 units.

Fig. 18 — Outdoor-Air Hood Details

Step 9 — Install All Accessories — After all the factory-installed options have been adjusted, install all field-installed accessories. Refer to the accessory installation instructions included with each accessory.

MOTORMASTER® I CONTROL INSTALLATION (50TM016, 020, and 028 Only)

Install Field-Fabricated Wind Baffles — Wind baffles must be field-fabricated for all units to ensure proper cooling cycle operation at low ambient temperatures. See Fig. 19 for baffle details. Use 20-gage, galvanized sheet metal, or similar corrosion-resistant metal for baffles. Use field-supplied screws to attach baffles to unit. Screws should be 1/4-in. diameter and 5/8-in. long. Drill required screw holes for mounting baffles.

⚠ CAUTION

To avoid damage to the refrigerant coils and electrical components, use recommended screw sizes only. Use care when drilling holes.

Install Motormaster® I Controls — Only one Motormaster I control is required for size 016 and 020 units. Two Motormaster I controls are required for size 028 units — one for circuit 1 and one for circuit 2. The Motormaster I control must be used in conjunction with the Accessory 0° F Low Ambient Kit (purchased separately). The Motormaster I device controls outdoor fan no. 1 (and 4 on size 028 units) while outdoor fans no. 2 and 3 (and 5 and 6 on size 028 units) are sequenced off by the Accessory 0° F Low Ambient Kit.

Accessory 0° F Low Ambient Kit — Install the Accessory 0° F Low Ambient Kit per instruction supplied with accessory.

Sensor Assembly — Install the sensor assembly in the location shown in Fig. 20.

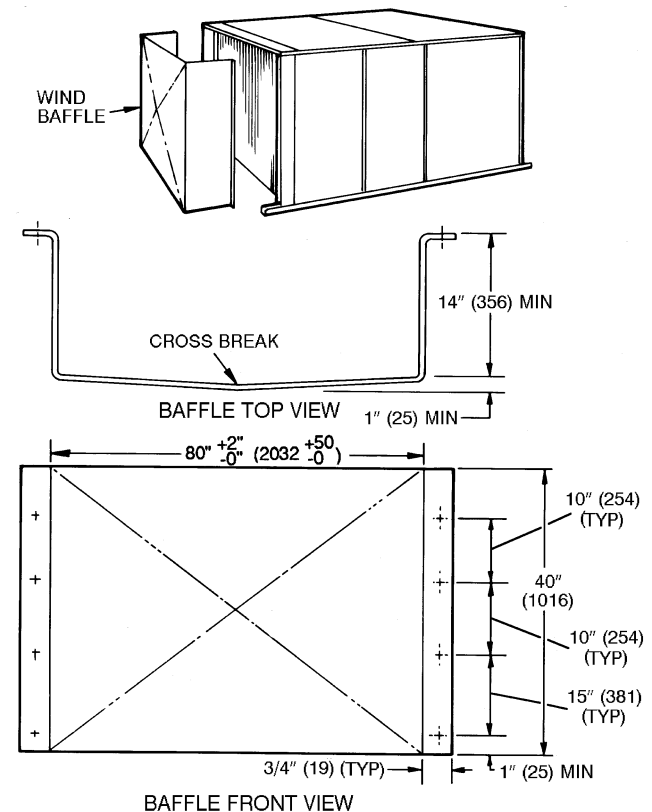

NOTE: Dimensions in () are in mm.

Fig. 19 — Wind Baffle Details

Motor Mount — To ensure proper fan height, replace the existing motor mount with the new motor mount provided with accessory.

Transformer (460 and 575-v Units Only) — On 460 and 575-volt units a transformer is required. The transformer is provided with the accessory and must be field-installed.

Motormaster I Control — Recommended mounting location is on the inside of the panel to the left of the control box. The control should be mounted on the inside of the panel, vertically, with leads protruding from bottom of extrusion.

MOTORMASTER® V CONTROL INSTALLATION (50TM025 only)

Install Field-Fabricated Wind Baffles — Wind baffles must be field-fabricated for all units to ensure proper cooling cycle operation at low ambient temperatures. See Fig. 19 for baffle details. Use 20-gage, galvanized sheet metal, or similar corrosion-resistant metal for baffles. Use field-supplied screws to attach baffles to unit. Screws should be 1/4-in. diameter and 5/8-in. long. Drill required screw holes for mounting baffles.

⚠ CAUTION

To avoid damage to the refrigerant coils and electrical components, use recommended screw sizes only. Use care when drilling holes.

Install Motormaster V Controls — The Motormaster V control is a motor speed control device which adjusts condenser fan motor speed in response to declining liquid refrigerant pressure. A properly applied Motormaster V control extends the operating range of air-conditioning systems and permits operation at lower outdoor ambient temperatures.

The minimum ambient temperatures at which the unit will operate are:

TEMPERATURE OPERATING LIMITS — F° (C°)		
Standard Unit	Unit with Low Ambient Kit	Unit with MMV Control
40 (4)	25 (-4)	-20 (-29)

To operate down to the ambient temperatures listed, Motormaster V controls (Fig. 21) must be added. Field-fabricated and installed wind baffles are also required for all units (see Fig. 19). The Motormaster V control permits operation of the unit to an ambient temperature of -20 F (-29 C). The control regulates the speed of 3-phase fan motors that are compatible with the control. These motors are factory installed.

See Table 4 for the Motormaster V control accessory package usage. Table 5 shows applicable voltages and motors. Replacement of fan motor **IS NOT REQUIRED ON CURRENT PRODUCTION UNITS** since the control is compatible with the factory-installed fan motors. Only field wiring control is required.

Install the Motormaster V control per instructions supplied with accessory.

Table 4 — Motormaster V Control Package Usage

UNIT	VOLTAGE	ITEM DESCRIPTION
50TM025	208/230	CRLOWAMB015A00
	460	CRLOWAMB016A00
	575	CRLOWAMB017A00

Table 5 — Applicable Voltages and Motors

VOLTAGE	COMPATIBLE MOTOR*
208/230-3-60	HD52AK654
460-3-60	HD52AK654
575-3-60	HD52GE576

*Motormaster V compatible motors, P/N HD52AK654 for 208/230, 460 v and P/N HD52GE576 for 575 v, are installed in units with serial numbers 2801F and later. For units with serial numbers before 2801F, motor changeout is required prior to installing the Motormaster V control package.

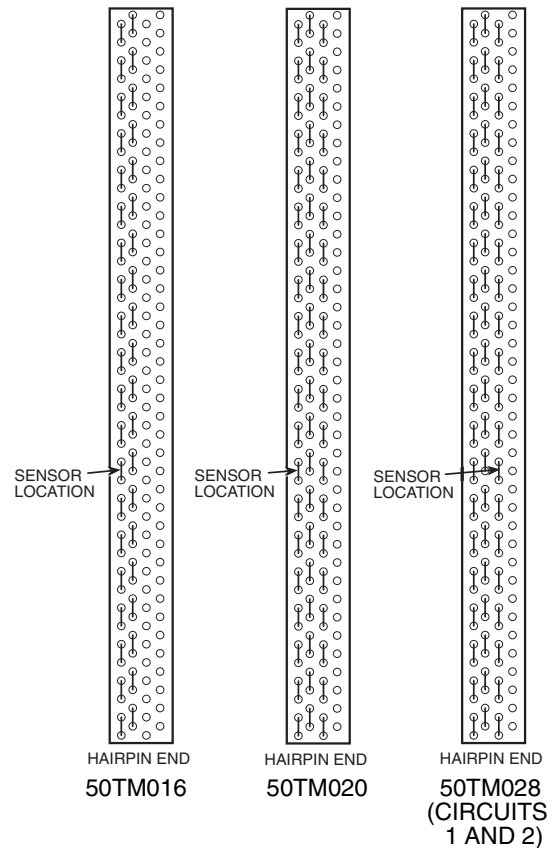

NOTE: All sensors are located on the eighth hairpin up from the bottom.

Fig. 20 — Motormaster® I Sensor Locations

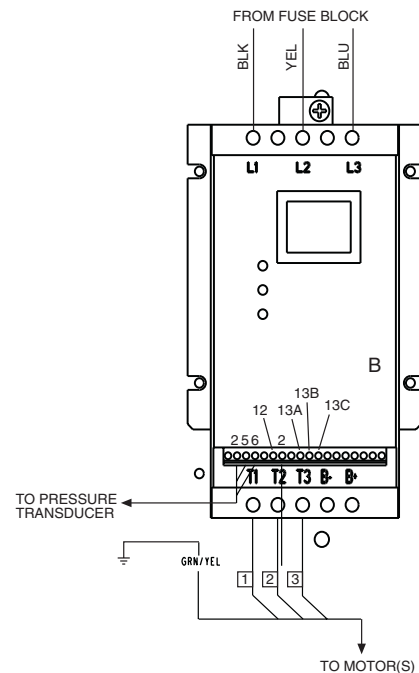

Fig. 21 — Motormaster® V Control

Table 6 — PremierLink™ Sensor Usage

APPLICATION	OUTDOOR AIR TEMPERATURE SENSOR	RETURN AIR TEMPERATURE SENSOR	OUTDOOR AIR ENTHALPY SENSOR	RETURN AIR ENTHALPY SENSOR
Differential Dry Bulb Temperature with PremierLink* (PremierLink requires 4-20 mA Actuator)	Included — HH79NZ039	Required — 33ZCT55SPT or Equivalent	—	—
Single Enthalpy with PremierLink* (PremierLink requires 4-20 mA Actuator)	Included — Not Used	—	Required — 33CSENTHSW or HH57AC077	—
Differential Enthalpy with PremierLink* (PremierLink requires 4-20 mA Actuator)	Included — Not Used	—	Required — 33CSENTHSW (HH57ZC003) or HH57AC077	Required — 33CSENTSEN or HH57AC078

*PremierLink control requires supply air temperature sensor 33ZCSENSAT and outdoor air temperature sensor HH79NZ039 — Included with factory-installed PremierLink control; field-supplied and field-installed with field-installed PremierLink control.

NOTES:

- CO₂ Sensors (Optional):
 - 33ZCSENCO2 — Room sensor (adjustable). Aspirator box is required for duct mounting of the sensor.
 - 33ZCASPCO2 — Aspirator box used for duct-mounted CO₂ room sensor.
 - 33ZCT55CO2 — Space temperature and CO₂ room sensor with override.
 - 33ZCT56CO2 — Space temperature and CO₂ room sensor with override and setpoint.
- All units include the following Standard Sensors:
 - Outdoor-air sensor — 50HJ540569 — Opens at 67 F, closes at 52 F, not adjustable.
 - Mixed-air sensor — HH97AZ001 — (PremierLink control requires supply air temperature sensor 33ZCSENSAT and outdoor air temperature sensor HH79NZ039)
 - Compressor lockout sensor — 50HJ540570 — Opens at 35 F, closes at 50 F.

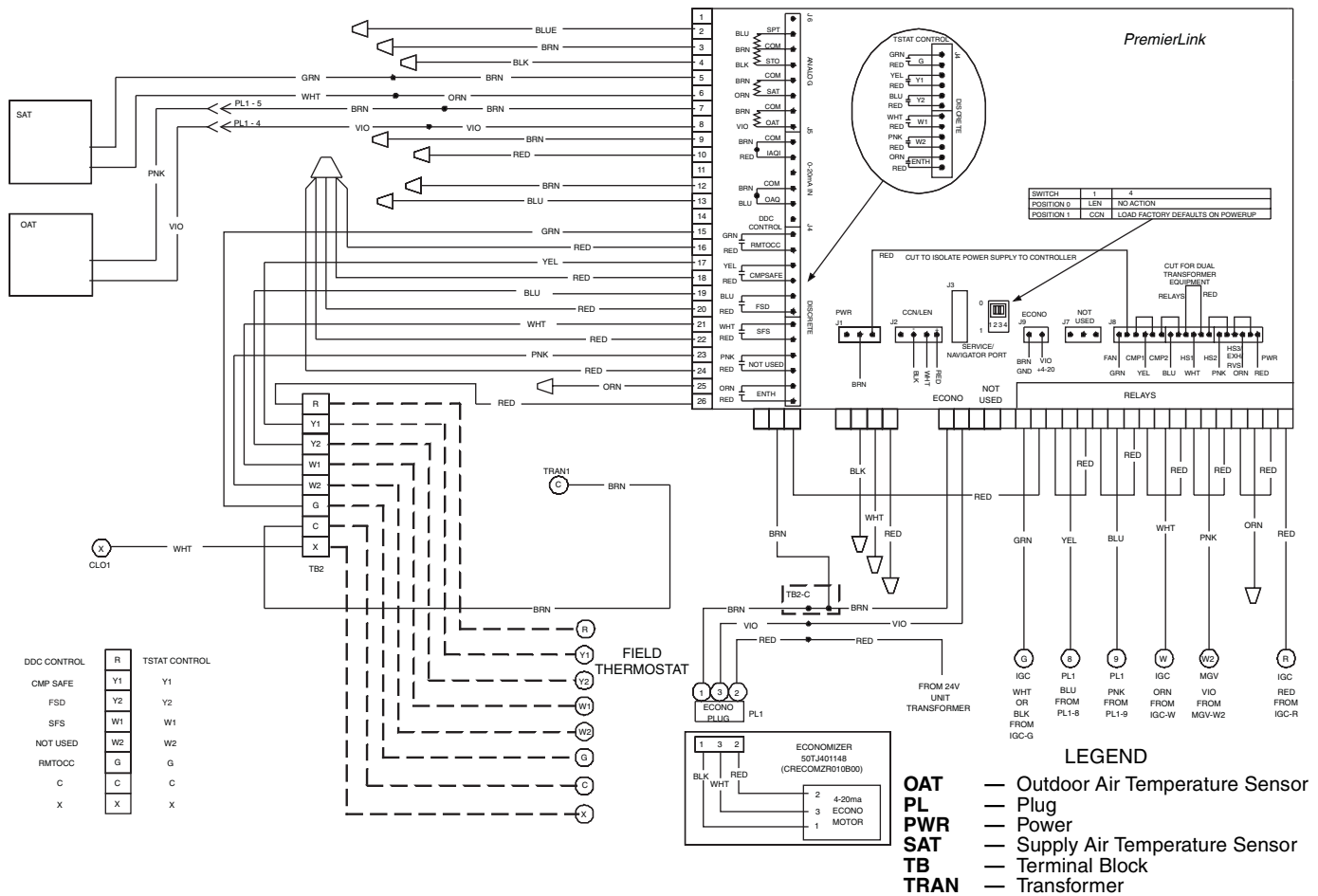

Fig. 23 — Typical PremierLink™ Controls Wiring (Thermostat Control Mode)

ENTHALPY SWITCH/RECEIVER — The accessory enthalpy switch/receiver (33CSENTHSW) senses temperature and humidity of the air surrounding the device and calculates the enthalpy when used without an enthalpy sensor. The relay is energized when enthalpy is high and deenergized when enthalpy is low (based on ASHRAE [American Society of Heating, Refrigeration and Air Conditioning Engineers] 90.1 criteria). If an accessory enthalpy sensor (33CSENSEN) is attached to the return air sensor input, then differential enthalpy is calculated. The relay is energized when the enthalpy detected by the return air enthalpy sensor is less than the enthalpy at the enthalpy switch/receiver. The relay is deenergized when the enthalpy detected by the return air enthalpy sensor is greater than the enthalpy at the enthalpy switch/receiver (differential enthalpy control). See Fig. 24 and 25.

OUTDOOR ENTHALPY CONTROL (Fig. 26) — Outdoor enthalpy control requires only an enthalpy switch/receiver (33CSENTHSW). The enthalpy switch/receiver is mounted in the outdoor air inlet and calculates outdoor air enthalpy. The enthalpy switch/receiver energizes the relay output when the outdoor enthalpy is above 28 BTU/lb **OR** dry bulb temperature is above 75 F and is deenergized when the outdoor enthalpy is below 27 BTU/lb **AND** dry bulb temperature is below 74.5 F. The relay output is wired to the unit economizer which will open or close depending on the output of the switch.

NOTE: The enthalpy calculation is done using an average altitude of 1000 ft above sea level.

Mounting — Mount the enthalpy switch/receiver in a location where the outdoor air can be sampled (such as the outdoor air intake). The enthalpy switch/receiver is not a NEMA 4

(National Electrical Manufacturers Association) enclosure and should be mounted in a location that is not exposed to outdoor elements such as rain or snow. Use two field-supplied no. 8 x 3/4-in. TEK screws. Insert the screws through the holes in the sides of the enthalpy switch/receiver.

Wiring — Carrier recommends the use of 18 to 22 AWG (American Wire Gage) twisted pair or shielded cable for all wiring. All connections must be made with 1/4-in. female spade connectors.

A 24-vac transformer is required to power the enthalpy switch/receiver; as shown in Fig. 26, the PremierLink board provides 24 vac. Connect the GND and 24 VAC terminals on the enthalpy switch/receiver to the terminals on the transformer. On some applications, the power from the economizer harness can be used to power the enthalpy switch/receiver. To power the enthalpy switch/receiver from the economizer harness, connect power of the enthalpy switch/receiver to the red and brown wires (1 and 4) on the economizer harness.

For connection to rooftop units with PremierLink control, connect the LOW Enthalpy terminal on the enthalpy switch/receiver to J4 — pin 2 of the PremierLink control on the HVAC unit. The switch can be powered through the PremierLink control board if desired. Wire the 24 VAC terminal on the enthalpy switch/receiver to J4 — pin 1 on the PremierLink control. Wire the GND terminal on the enthalpy switch/receiver to J1 — pin 2 on the PremierLink control. The HI Enthalpy terminal is not used. See Fig. 26.

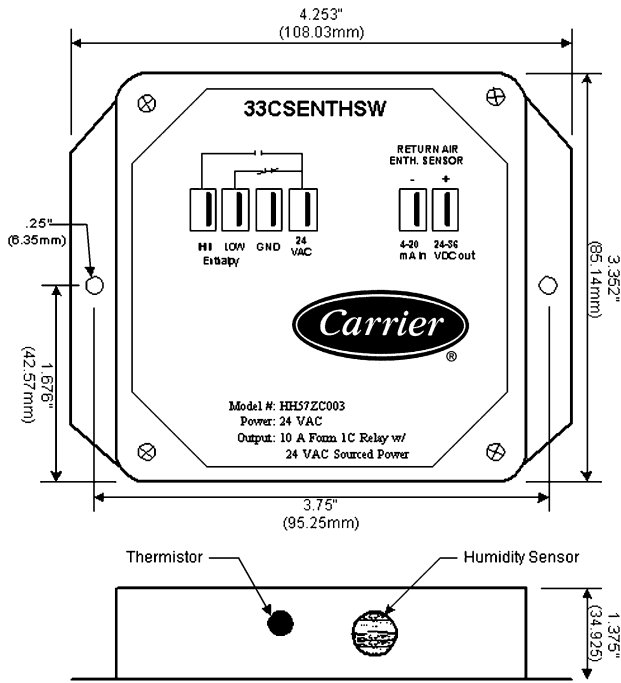

Fig. 24 — Enthalpy Switch/Receiver Dimensions (33CSENTHSW)

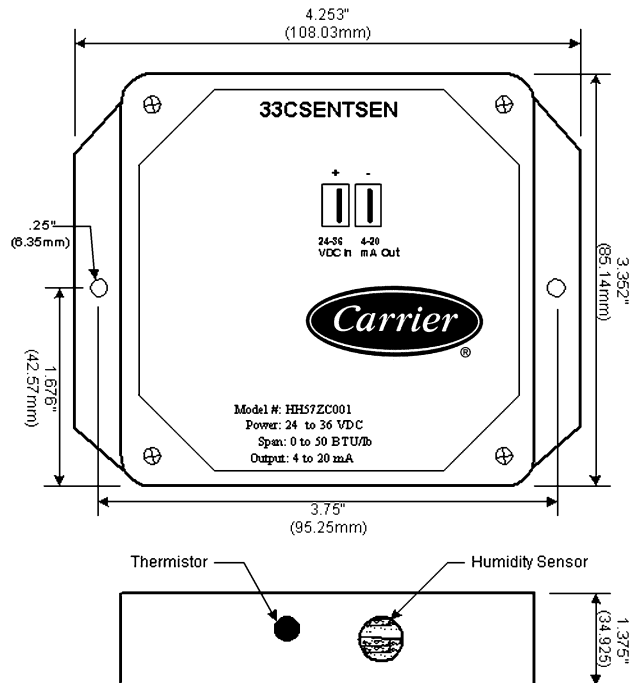

Fig. 25 — Enthalpy Sensor Dimensions (33CSENSEN)

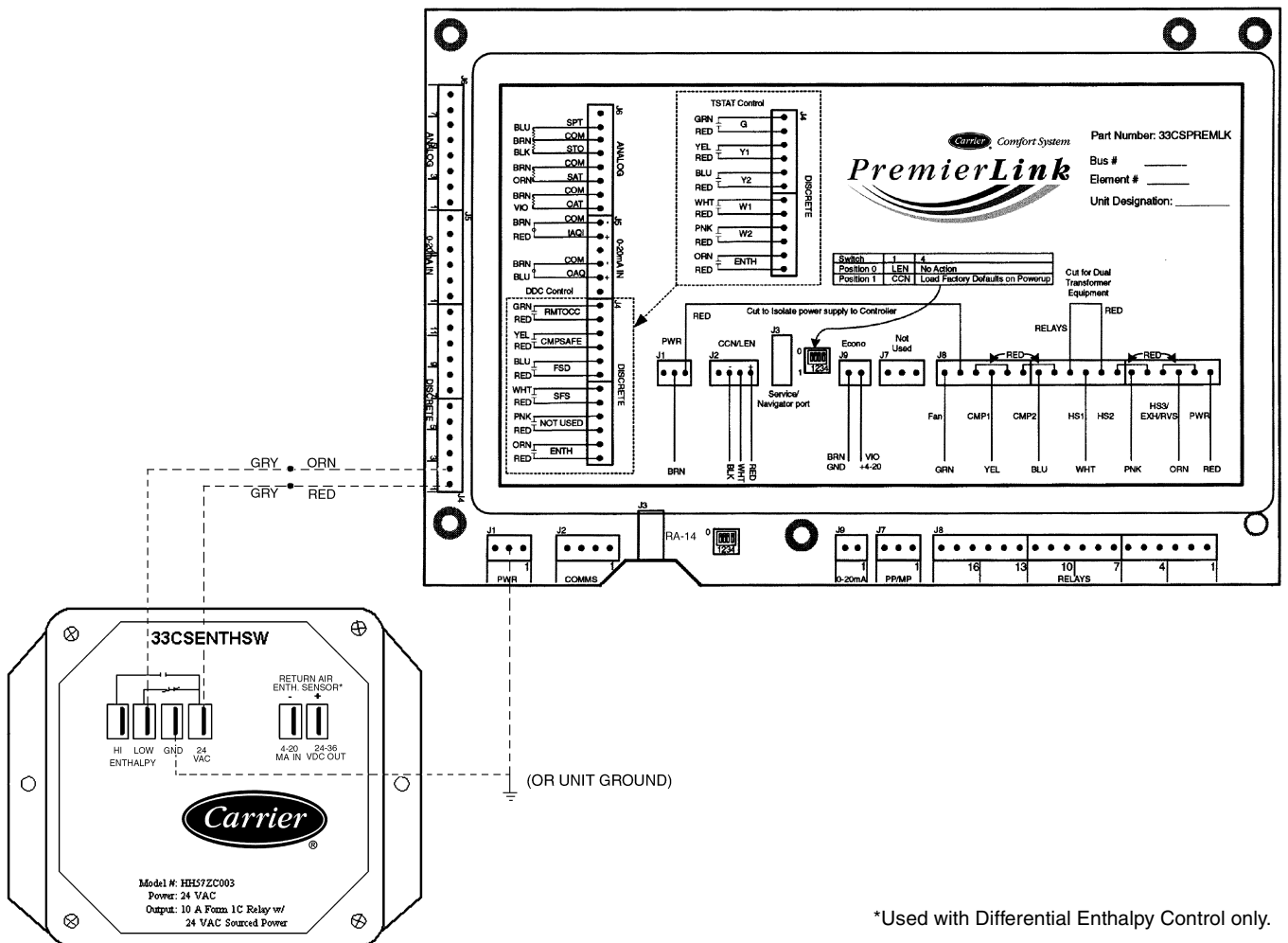

Fig. 26 — Typical Wiring Schematic — Carrier Rooftop Unit with PremierLink™ Controls

*Used with Differential Enthalpy Control only.

DIFFERENTIAL ENTHALPY CONTROL (Fig. 27) — Differential enthalpy control requires both an enthalpy switch/receiver (33CSENTHSW) and an enthalpy sensor (33CSENSEN). The enthalpy switch/receiver is mounted in the outdoor air inlet and calculates outdoor air enthalpy. The enthalpy sensor is mounted in the return airstream and calculates the enthalpy of the indoor air.

The enthalpy switch/receiver energizes the HI Enthalpy relay output when the outdoor enthalpy is greater than the indoor enthalpy. The LOW Enthalpy terminal is energized when the outdoor enthalpy is lower than the indoor enthalpy. The relay output is wired to the unit economizer which will open or close depending on the output of the switch.

NOTE: The enthalpy calculation is done using an average altitude of 1000 ft above sea level.

Mounting — Mount the enthalpy switch/receiver in a location where the outdoor air can be sampled (such as the outdoor air intake). The enthalpy switch/receiver is not a NEMA 4 enclosure and should be mounted in a location that is not exposed to outdoor elements such as rain, snow, or direct sunlight. Use two field-supplied no. 8 x 3/4-in. TEK screws. Insert the screws through the holes in the sides of the enthalpy switch/receiver.

Mount the enthalpy sensor in a location where the indoor air can be sampled (such as the return air duct). The enthalpy sensor is not a NEMA 4 enclosure and should be mounted in a location that is not exposed to outdoor elements such as rain or snow. Use two field-supplied no. 8 x 3/4-in. TEK screws. Insert the screws through the holes in the sides of the enthalpy sensor.

Wiring — Carrier recommends the use of 18 to 22 AWG twisted pair or shielded cable for all wiring. All connections must be made with 1/4-in. female spade connectors.

The PremierLink™ board provides 24 vac to power the enthalpy switch/receiver. Connect the GND and 24 VAC terminals on the enthalpy switch/receiver to the terminals on the transformer. On some applications, the power from the economizer harness can be used to power the enthalpy switch/receiver. To power the enthalpy switch/receiver from the economizer harness, connect power of the enthalpy switch/receiver to the red and brown wires (1 and 4) on the economizer harness.

Connect the LOW Enthalpy terminal on the enthalpy switch/receiver to J4 — pin 2 of the PremierLink control on the HVAC unit. The switch can be powered through the PremierLink control board if desired. Wire the 24 VAC terminal on the enthalpy switch/receiver to J4 — pin 1 on the PremierLink control. Wire the GND terminal on the enthalpy switch/receiver to J1 — pin 2 on the PremierLink control. The HI Enthalpy terminal is not used. See Fig. 27.

Connect the 4-20 mA IN terminal on the enthalpy switch/receiver to the 4-20 mA OUT terminal on the return air enthalpy sensor. Connect the 24-36 VDC OUT terminal on the enthalpy switch/receiver to the 24-36 VDC IN terminal on the return air enthalpy sensor. See Fig. 27.

Enthalpy Switch/Receiver Jumper Settings — There are two jumpers. One jumper determines the mode of the enthalpy switch/receiver. The other jumper is not used. To access the jumpers, remove the 4 screws holding the cover on the enthalpy switch/receiver and then remove the cover. The factory settings for the jumpers are M1 and OFF.

The mode jumper should be set to M2 for differential enthalpy control. The factory test jumper should remain on OFF or the enthalpy switch/receiver will not calculate enthalpy.

Enthalpy Sensor Jumper Settings — There are two jumpers. One jumper determines the mode of the enthalpy sensor. The other jumper is not used. To access the jumpers, remove the

4 screws holding the cover on the enthalpy sensor and then remove the cover. The factory settings for the jumpers are M3 and OFF.

The mode jumper should be set to M3 for 4 to 20 mA output. The factory test jumper should remain on OFF or the enthalpy sensor will not calculate enthalpy.

ENTHALPY SENSORS AND CONTROL — The enthalpy control (HH57AC077) is supplied as a field-installed accessory to be used with the EconoMiSer2 damper control option. The outdoor air enthalpy sensor is part of the enthalpy control. The separate field-installed accessory return air enthalpy sensor (HH57AC078) is required for differential enthalpy control.

NOTE: The enthalpy control must be set to the “D” setting for differential enthalpy control to work properly.

The enthalpy control receives the indoor and return enthalpy from the outdoor and return air enthalpy sensors and provides a dry contact switch input to the PremierLink controller. Locate the controller in place of an existing economizer controller or near the actuator. The mounting plate may not be needed if existing bracket is used.

A closed contact indicates that outside air is preferred to the return air. An open contact indicates that the economizer should remain at minimum position.

Outdoor Air Enthalpy Sensor/Enthalpy Controller (HH57AC077) — To wire the outdoor air enthalpy sensor, perform the following (see Fig. 28 and 29):

NOTE: The outdoor air sensor can be removed from the back of the enthalpy controller and mounted remotely.

1. Use a 4-conductor, 18 or 20 AWG cable to connect the enthalpy control to the PremierLink controller and power transformer.
2. Connect the following 4 wires from the wire harness located in rooftop unit to the enthalpy controller:
 - a. Connect the BRN wire to the 24 vac terminal (TR1) on enthalpy control and to pin 1 on 12-pin harness.
 - b. Connect the RED wire to the 24 vac GND terminal (TR) on enthalpy sensor and to pin 4 on 12-pin harness.
 - c. Connect the GRAY/ORN wire to J4-2 on PremierLink controller and to terminal (3) on enthalpy sensor.
 - d. Connect the GRAY/RED wire to J4-1 on PremierLink controller and to terminal (2) on enthalpy sensor.

NOTE: Use the two gray wires provided from the control section to the economizer to connect PremierLink controller to terminals 2 and 3 on enthalpy sensor.

Return Air Enthalpy Sensor — Mount the return-air enthalpy sensor (HH57AC078) in the return-air duct. The return air sensor is wired to the enthalpy controller (HH57AC077). The outdoor enthalpy changeover set point is set at the controller.

To wire the return air enthalpy sensor, perform the following (see Fig. 28):

1. Use a 2-conductor, 18 or 20 AWG, twisted pair cable to connect the return air enthalpy sensor to the enthalpy controller.
2. At the enthalpy control remove the factory-installed resistor from the (SR) and (+) terminals.
3. Connect the field-supplied RED wire to (+) spade connector on the return air enthalpy sensor and the (SR+) terminal on the enthalpy controller. Connect the BLK wire to (S) spade connector on the return air enthalpy sensor and the (SR) terminal on the enthalpy controller.

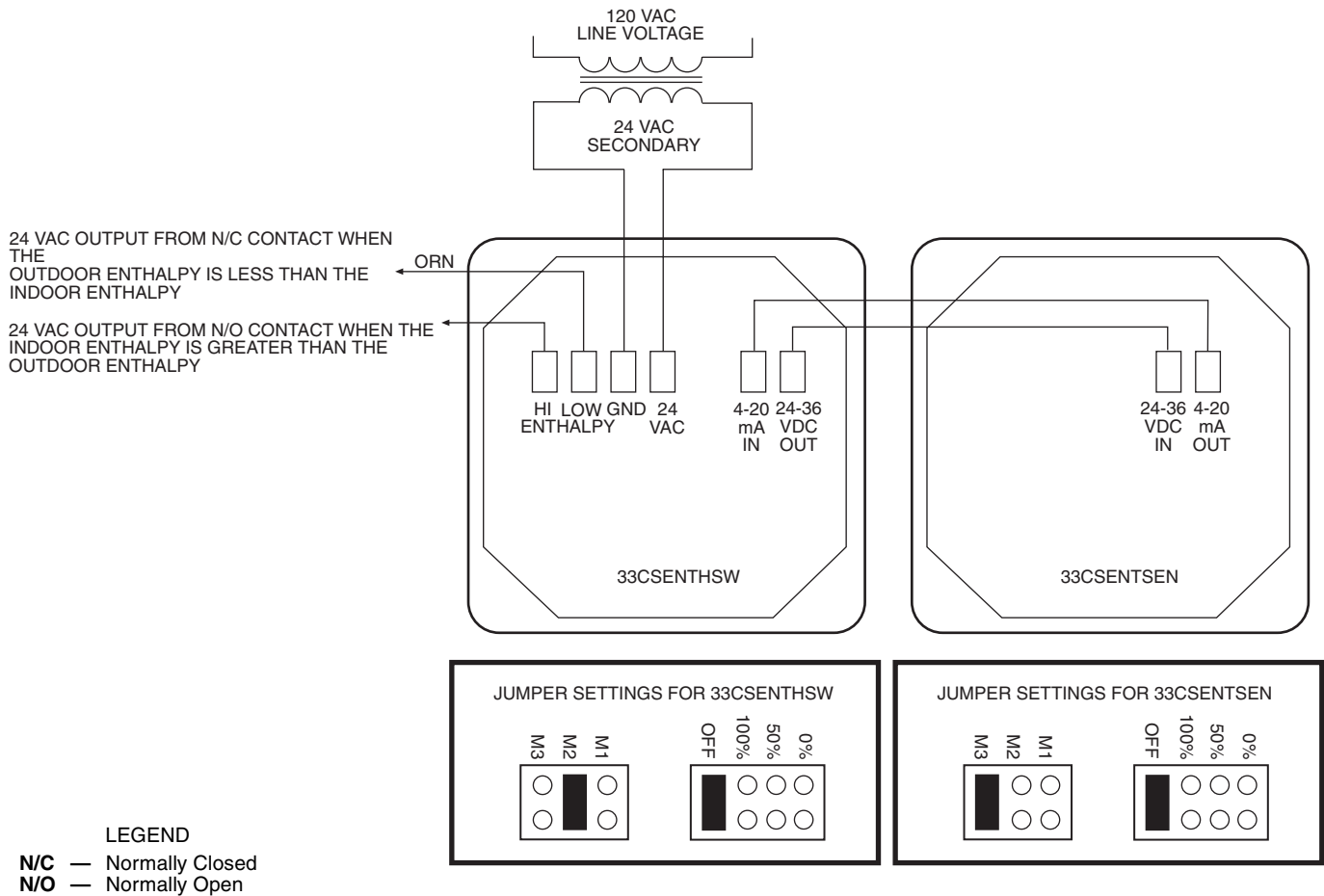
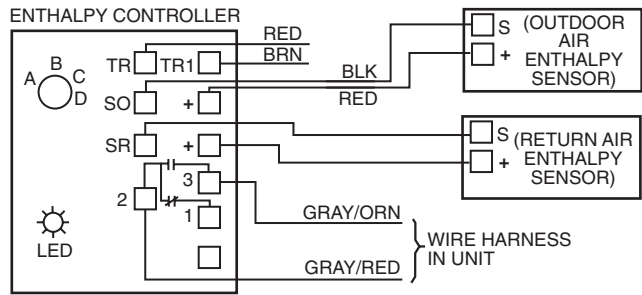

Fig. 27 — Differential Enthalpy Control Wiring



- NOTES:
1. Remove factory-installed jumper across SR and + before connecting wires from return air sensor.
 2. Switches shown in high outdoor air enthalpy state. Terminals 2 and 3 close on low outdoor air enthalpy relative to indoor air enthalpy.
 3. Remove sensor mounted on back of control and locate in outside airstream.

Fig. 28 — Outdoor and Return Air Sensor Wiring Connections for Differential Enthalpy Control

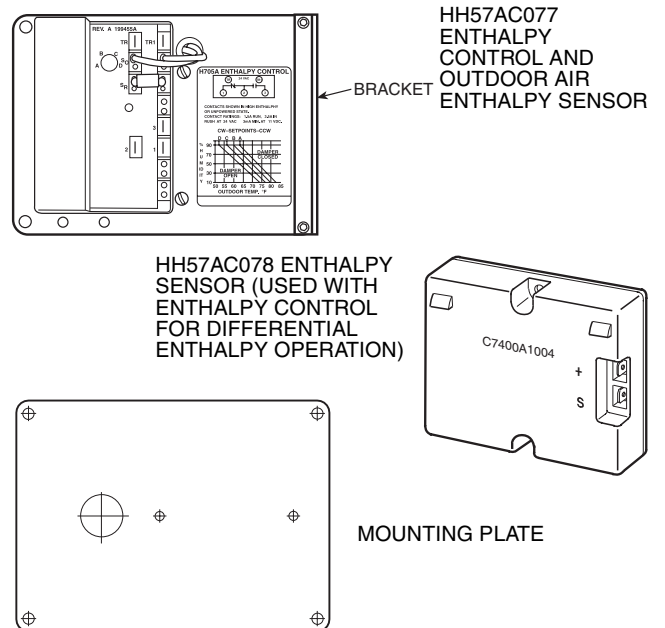

Fig. 29 — Differential Enthalpy Control, Sensor and Mounting Plate (33AMKITENT006)

OPTIONAL ECONOMISERIV AND ECONOMISER2 — See Fig. 30 and 31 for EconoMiSerIV component locations. See Fig. 32 for EconoMiSer2 component locations.

NOTE: These instructions are for installing the optional EconoMiSerIV and EconoMiSer2 only. Refer to the accessory EconoMiSerIV or EconoMiSer2 installation instructions when field installing an EconoMiSerIV or EconoMiSer2 accessory.

To complete installation of the optional EconoMiSerIV, perform the following procedure.

1. Remove the EconoMiSerIV hood. Refer to Step 8 — Install Outdoor-Air Hood on page 13 for information on removing and installing the outdoor-air hood.
2. Relocate outdoor air temperature sensor from shipping position to operation position on EconoMiSerIV. See Fig. 30.

IMPORTANT: Failure to relocate the sensor will result in the EconoMiSerIV not operating properly.

3. Re-install economizer hood.
4. Install all EconoMiSerIV accessories. EconoMiSerIV wiring is shown in Fig. 33. EconoMiSer2 wiring is shown in Fig. 34.

Outdoor air leakage is shown in Table 7. Return air pressure drop is shown in Table 8.

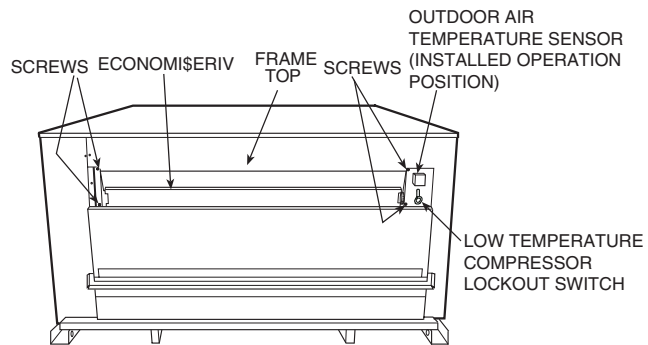

Fig. 30 — EconoMiSerIV Component Locations — End View

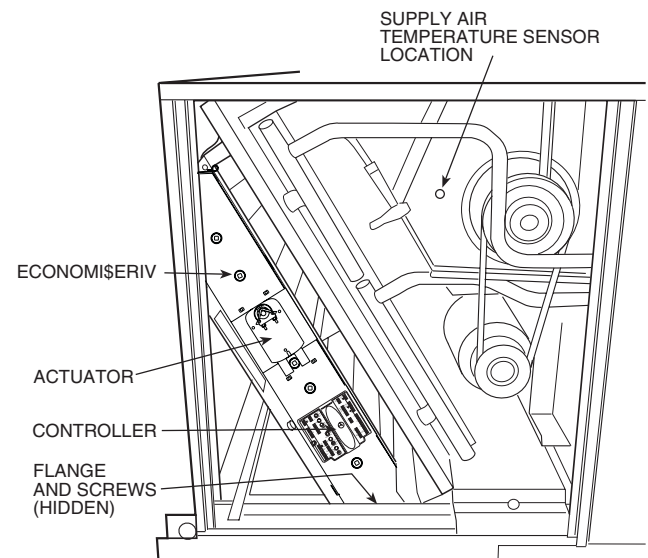

Fig. 31 — EconoMiSerIV Component Locations — Side View

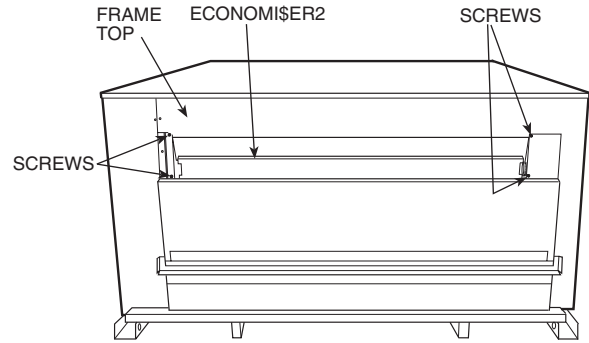

Fig. 32 — EconoMiSer2 Component Locations

Table 7 — Outdoor Air Damper Leakage

LEAKAGE (cfm)	DAMPER STATIC PRESSURE (in. wg)					
	0.2	0.4	0.6	0.8	1.0	1.2
	35	53	65	75	90	102

Table 8 — Return Air Pressure Drop (in. wg)

CFM									
4500	5000	5400	6000	7200	7500	9000	10,000	11,250	
0.040	0.050	0.060	0.070	0.090	0.100	0.110	0.120	0.140	

ECONOMISERIV STANDARD SENSORS

Outdoor Air Temperature (OAT) Sensor — The outdoor air temperature sensor (HH57AC074) is a 10 to 20 mA device used to measure the outdoor-air temperature. The outdoor-air temperature is used to determine when the EconoMiSerIV can be used for free cooling. The sensor must be field-relocated. See Fig. 30. The operating range of temperature measurement is 40 to 100 F.

Supply Air Temperature (SAT) Sensor — The supply air temperature sensor is a 3 K thermistor located at the inlet of the indoor fan. See Fig. 31. This sensor is factory installed. The operating range of temperature measurement is 0° to 158 F. See Table 9 for sensor temperature/resistance values.

The temperature sensor looks like an eyelet terminal with wires running to it. The sensor is located in the “crimp end” and is sealed from moisture.

Low Temperature Compressor Lockout Switch — The EconoMiSerIV is equipped with an ambient temperature lockout switch located in the outdoor airstream which is used to lockout the compressors below a 42 F ambient temperature. See Fig. 30.

Table 9 — Supply Air Sensor Temperature/Resistance Values

TEMPERATURE (F)	RESISTANCE (ohms)
-58	200,250
-40	100,680
-22	53,010
-4	29,091
14	16,590
32	9,795
50	5,970
68	3,747
77	3,000
86	2,416
104	1,597
122	1,080
140	746
158	525
176	376
185	321
194	274
212	203
230	153
248	116
257	102
266	89
284	70
302	55

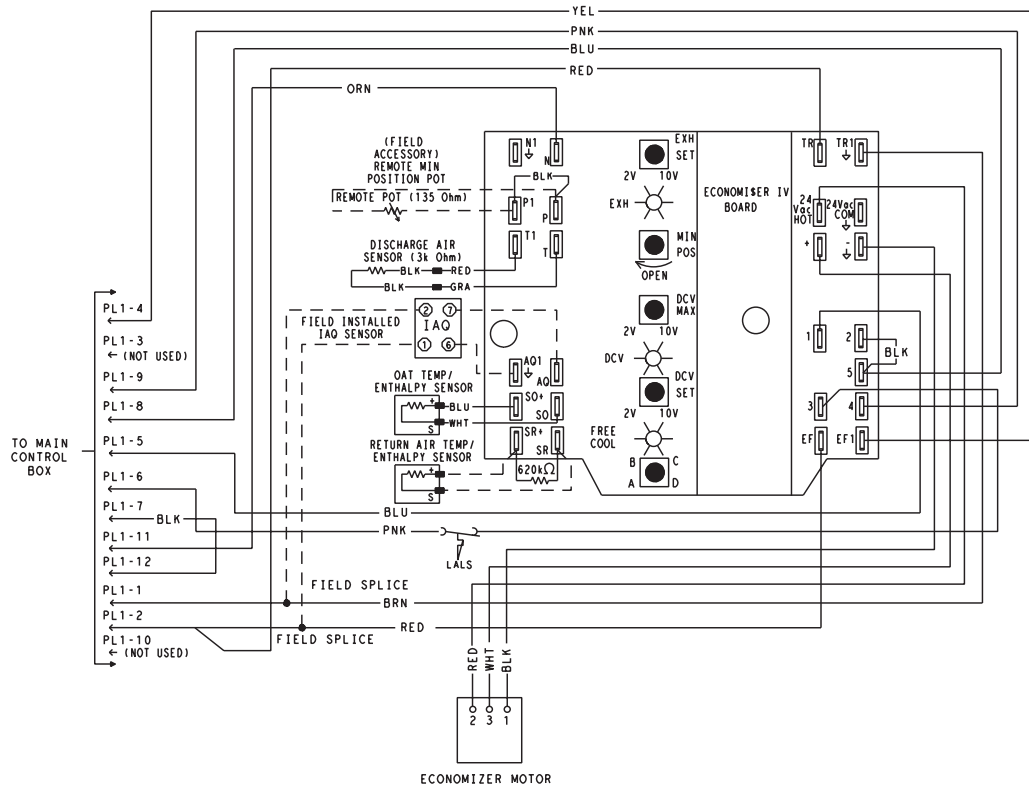

LEGEND
DCV — Demand Controlled Ventilation
IAQ — Indoor Air Quality
LALS — Low Temperature Compressor Lockout Switch
OAT — Outdoor-Air Temperature
POT — Potentiometer

Potentiometer Default Settings:
 Power Exhaust Middle
 Minimum Pos. Fully Closed
 DCV Max. Middle
 DCV Set Middle
 Enthalpy C Setting

NOTES:
 1. 620 ohm, 1 watt 5% resistor should be removed only when using differential enthalpy or dry bulb.
 2. If a separate field-supplied 24 v transformer is used for the IAQ sensor power supply, it cannot have the secondary of the transformer grounded.
 3. For field-installed remote minimum position POT, remove black wire jumper between P and P1 and set control minimum position POT to the minimum position.

Fig. 33 — EconoMiSerIV Wiring

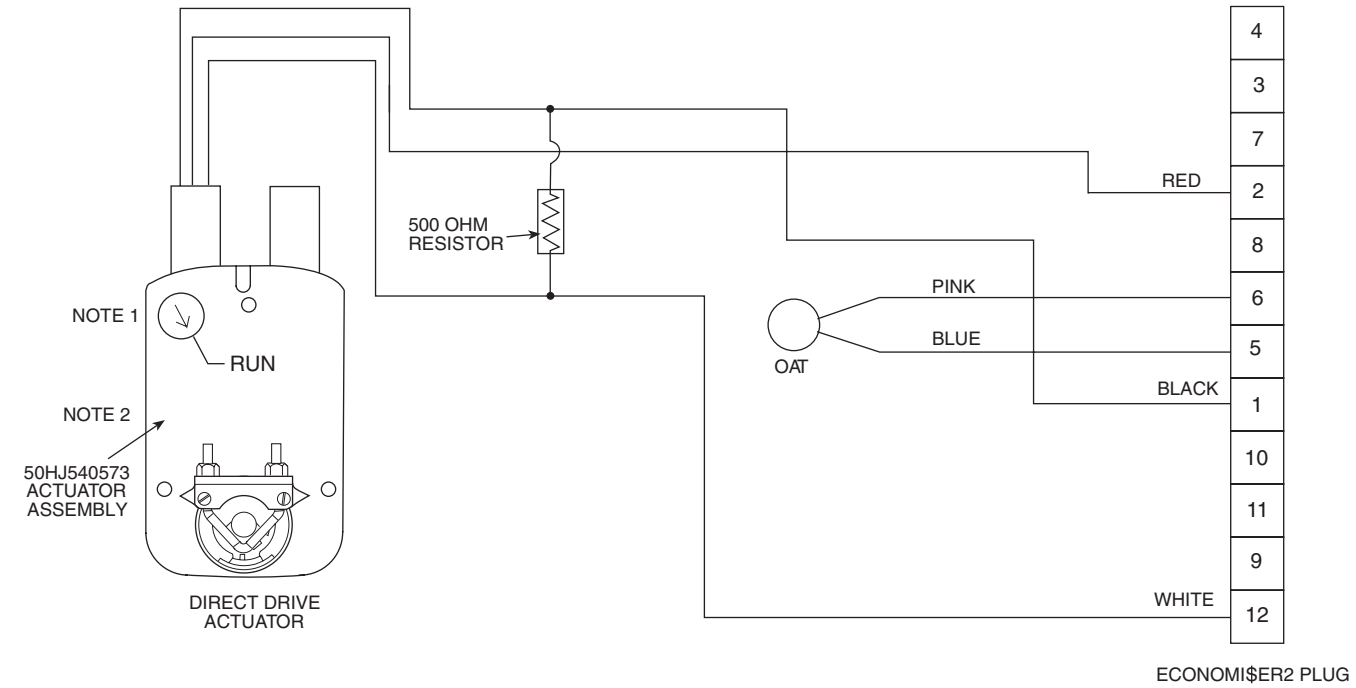

LEGEND
OAT — Outdoor Air Temperature Sensor

NOTES:
 1. Switch on actuator must be in run position for economizer to operate.
 2. 50HJ540573 actuator consists of the 50HJ540567 actuator and a harness with 500-ohm resistor.

Fig. 34 — EconoMiSer2 Wiring

ECONOMISERIV CONTROL MODES

IMPORTANT: The optional EconoMiSer2 does not include a controller. The EconoMiSer2 is operated by a 4 to 20 mA signal from an existing field-supplied controller (such as PremierLink™ control). See Fig. 34 for wiring information.

Determine the EconoMiSerIV control mode before set up of the control. Some modes of operation may require different sensors. Refer to Table 10. The EconoMiSerIV is supplied from the factory with a supply air temperature sensor, a low temperature compressor lockout switch, and an outdoor air temperature sensor. This allows for operation of the EconoMiSerIV with outdoor air dry bulb changeover control. Additional accessories can be added to allow for different types of changeover control and operation of the EconoMiSerIV and unit.

Table 10 — EconoMiSerIV Sensor Usage

APPLICATION	ECONOMISER IV WITH OUTDOOR AIR DRY BULB SENSOR		
	Accessories Required		
Outdoor Air Dry Bulb	None. The outdoor air dry bulb sensor is factory installed.		
Differential Dry Bulb	CRTEMPSN002A00*		
Single Enthalpy	HH57AC078		
Differential Enthalpy	HH57AC078 and CRENTDIF004A00*		
CO ₂ for DCV Control using a Wall-Mounted CO ₂ Sensor	33ZCSENCO2		
CO ₂ for DCV Control using a Duct-Mounted CO ₂ Sensor	33ZCSENCO2† and 33ZCASPCO2**	†	CRCBDIOX005A00††

*CRENTDIF004A00 and CRTEMPSN002A00 accessories are used on many different base units. As such, these kits may contain parts that will not be needed for installation.
 †33ZCSENCO2 is an accessory CO₂ sensor.
 **33ZCASPCO2 is an accessory aspirator box required for duct-mounted applications.
 ††CRCBDIOX005A00 is an accessory that contains both 33ZCSENCO2 and 33ZCASPCO2 accessories.

Outdoor Dry Bulb Changeover — The standard controller is shipped from the factory configured for outdoor dry bulb changeover control. The outdoor air and supply air temperature sensors are included as standard. For this control mode, the outdoor temperature is compared to an adjustable set point selected on the control. If the outdoor-air temperature is above the set point, the EconoMiSerIV will adjust the outside air dampers to minimum position. If the outdoor-air temperature is below the set point, the position of the outdoor air dampers will be controlled to provide free cooling using outdoor air. When in this mode, the LED next to the free cooling set point potentiometer will be on. The changeover temperature set point is controlled by the free cooling set point potentiometer located on the control. See Fig. 35. The scale on the potentiometer is A, B, C, and D. See Fig. 36 for the corresponding temperature changeover values.

Differential Dry Bulb Control — For differential dry bulb control the standard outdoor dry bulb sensor is used in conjunction with an additional accessory return air sensor (part number CRTEMPSN002A00). The accessory sensor must be mounted in the return airstream. See Fig. 37.

In this mode of operation, the outdoor-air temperature is compared to the return-air temperature and the lower temperature airstream is used for cooling. When using this mode of changeover control, turn the free cooling/enthalpy setpoint potentiometer fully clockwise to the D setting. See Fig. 35.

Outdoor Enthalpy Changeover — For enthalpy control, accessory enthalpy sensor (part number HH57AC078) is required. Replace the standard outdoor dry bulb temperature sensor with the accessory enthalpy sensor in the same mounting location. See Fig. 30. When the outdoor air enthalpy rises above the outdoor enthalpy changeover set point, the outdoor-air damper moves to its minimum position. The outdoor enthalpy changeover set point is set with the outdoor enthalpy set point potentiometer on the EconoMiSerIV controller. The set points are A, B, C, and D. See Fig. 38. The factory-installed 620-ohm jumper must be in place across terminals SR and SR+ on the EconoMiSerIV controller. See Fig. 33 and 39.

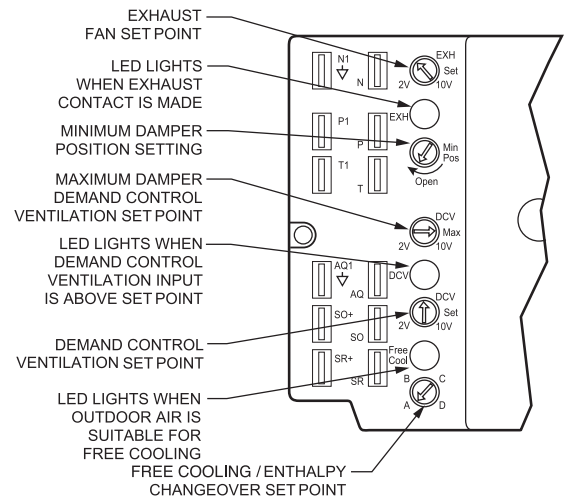

Fig. 35 — EconoMiSerIV Controller Potentiometer and LED Locations

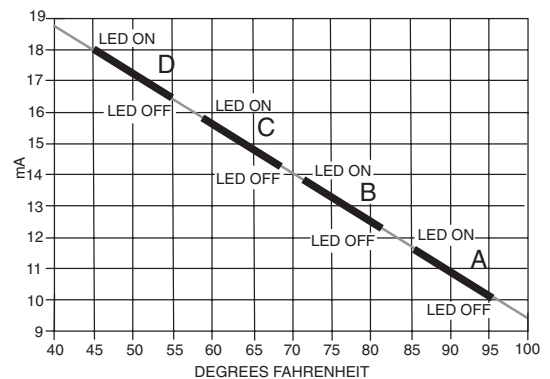

Fig. 36 — Outside Air Temperature Changeover Set Points

Differential Enthalpy Control — For differential enthalpy control, the EconoMi\$erIV controller uses two enthalpy sensors (HH57AC078 and CRENTDIF004A00), one in the outside air and one in the return airstream on the EconoMi\$erIV frame. The EconoMi\$erIV controller compares the outdoor air enthalpy to the return air enthalpy to determine EconoMi\$erIV use. The controller selects the lower enthalpy air (return or outdoor) for cooling. For example, when the outdoor air has a lower enthalpy than the return air and is below the set point, the EconoMi\$erIV opens to bring in outdoor air for free cooling.

Replace the standard outside air dry bulb temperature sensor with the accessory enthalpy sensor in the same mounting location. See Fig. 30. Mount the return air enthalpy sensor in the return airstream. See Fig. 37. The outdoor enthalpy changeover set point is set with the outdoor enthalpy set point potentiometer on the EconoMi\$erIV controller. When using this mode of changeover control, turn the enthalpy set point potentiometer fully clockwise to the D setting.

NOTE: Remove 620-ohm resistor if differential enthalpy sensor is installed.

Indoor Air Quality (IAQ) Sensor Input — The IAQ input can be used for demand control ventilation control based on the level of CO₂ measured in the space or return air duct.

Mount the accessory IAQ sensor according to manufacturer specifications. The IAQ sensor should be wired to the AQ and AQ1 terminals of the controller. Adjust the DCV potentiometers to correspond to the DCV voltage output of the indoor air quality sensor at the user-determined set point. See Fig. 40.

If a separate field-supplied transformer is used to power the IAQ sensor, the sensor must not be grounded or the EconoMi\$erIV control board will be damaged.

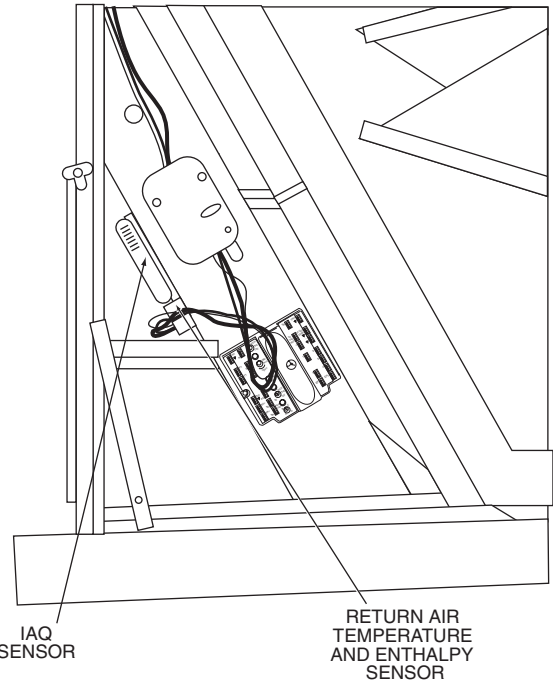

Fig. 37 — Return Air Temperature or Enthalpy Sensor Mounting Location

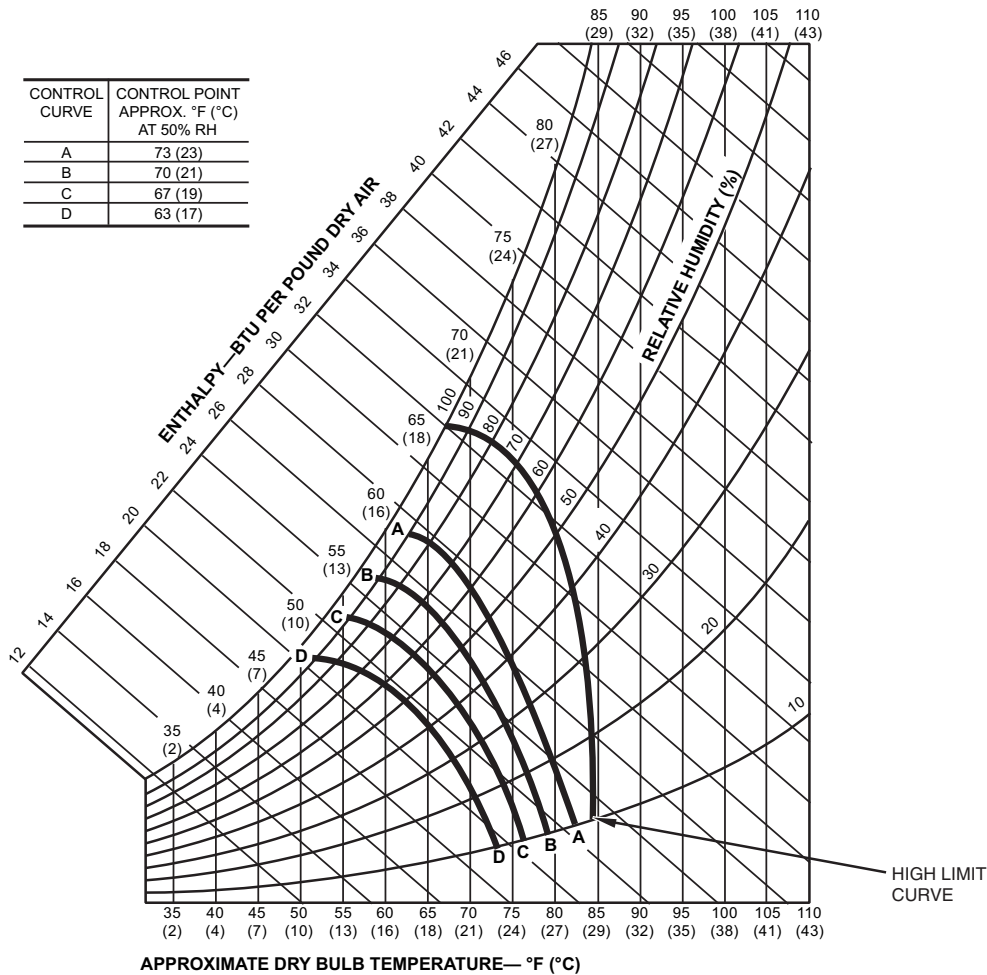

Fig. 38 — Enthalpy Changeover Set Points

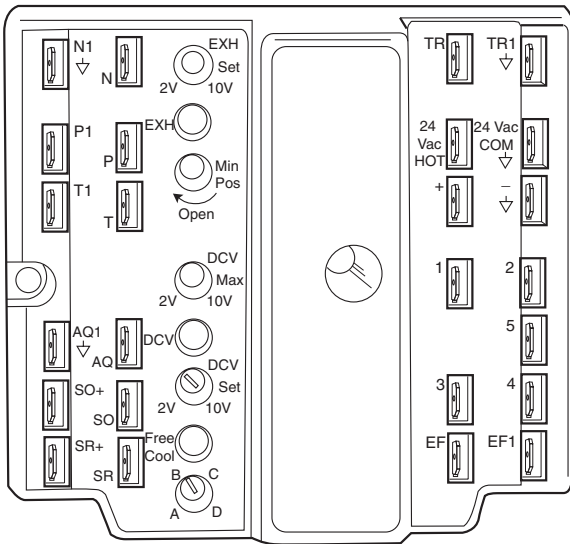

Fig. 39 — EconoMiSerIV Controller

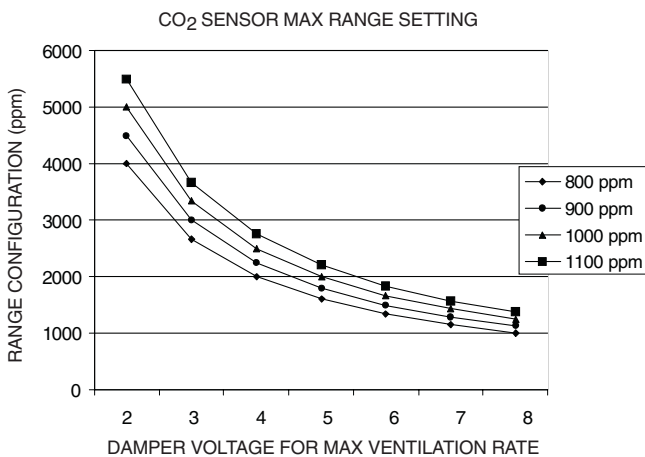

Fig. 40 — CO₂ Sensor Maximum Range Setting

Exhaust Set Point Adjustment — The exhaust set point will determine when the exhaust fan runs based on damper position (if accessory power exhaust is installed). The set point is modified with the Exhaust Fan Set Point (EXH SET) potentiometer. See Fig. 35. The set point represents the damper position above which the exhaust fan will be turned on. When there is a call for exhaust, the EconoMiSerIV controller provides a 45 ± 15 second delay before exhaust fan activation to allow the dampers to open. This delay allows the damper to reach the appropriate position to avoid unnecessary fan overload.

Minimum Position Control — There is a minimum damper position potentiometer on the EconoMiSerIV controller. See Fig. 35. The minimum damper position maintains the minimum airflow into the building during the occupied period.

When using demand ventilation, the minimum damper position represents the minimum ventilation position for VOC (volatile organic compound) ventilation requirements. The maximum demand ventilation position is used for fully occupied ventilation.

When demand ventilation control is not being used, the minimum position potentiometer should be used to set the occupied ventilation position. The maximum demand ventilation position should be turned fully clockwise.

Adjust the minimum position potentiometer to allow the minimum amount of outdoor air, as required by local codes, to enter the building. Make minimum position adjustments with

at least 10 F temperature difference between the outdoor and return-air temperatures.

To determine the minimum position setting, perform the following procedure:

1. Calculate the appropriate mixed air temperature using the following formula:

$$(T_O \times \frac{OA}{100}) + (T_R \times \frac{RA}{100}) = T_M$$

T_O = Outdoor-Air Temperature
 OA = Percent of Outdoor Air
 T_R = Return-Air Temperature
 RA = Percent of Return Air
 T_M = Mixed-Air Temperature

As an example, if local codes require 10% outdoor air during occupied conditions, outdoor-air temperature is 60 F, and return-air temperature is 75 F.

$$(60 \times .10) + (75 \times .90) = 73.5 \text{ F}$$

2. Disconnect the supply-air sensor from terminals T and T1.
3. Ensure that the factory-installed jumper is in place across terminals P and P1. If remote damper positioning is being used, make sure that the terminals are wired according to Fig. 33 and that the minimum position potentiometer is turned fully clockwise.
4. Connect 24 vac across terminals TR and TR1.
5. Carefully adjust the minimum position potentiometer until the measured mixed-air temperature matches the calculated value.
6. Reconnect the supply-air sensor to terminals T and T1.

Remote control of the EconoMiSerIV damper is desirable when requiring additional temporary ventilation. If a field-supplied remote potentiometer (Honeywell part number S963B1128) is wired to the EconoMiSerIV controller, the minimum position of the damper can be controlled from a remote location.

To control the minimum damper position remotely, remove the factory-installed jumper on the P and P1 terminals on the EconoMiSerIV controller. Wire the field-supplied potentiometer to the P and P1 terminals on the EconoMiSerIV controller. See Fig. 39.

Damper Movement — Damper movement from full open to full closed (or vice versa) takes 2½ minutes.

Thermostats — The EconoMiSerIV control works with conventional thermostats that have a Y1 (cool stage 1), Y2 (cool stage 2), W1 (heat stage 1), W2 (heat stage 2), and G (fan). The EconoMiSerIV control does not support space temperature sensors. Connections are made at the thermostat terminal connection board located in the main control box.

Occupancy Control — The factory default configuration for the EconoMiSerIV control is occupied mode. This is implemented by the RED jumper at TB2-9 to TB2-10. When unoccupied mode is desired, remove the RED jumper and install a field-supplied timeclock function between TB2-9 and TB2-10. When the timeclock contacts are open, the unit control will be in unoccupied mode; when contacts are closed, the unit control will be in occupied mode.

Demand Controlled Ventilation (DCV) — When using the EconoMiSerIV for demand controlled ventilation, there are some equipment selection criteria which should be considered. When selecting the heat capacity and cool capacity of the equipment, the maximum ventilation rate must be evaluated for design conditions. The maximum damper position must be calculated to provide the desired fresh air.

Typically the maximum ventilation rate will be about 5 to 10% more than the typical cfm required per person, using normal outside air design criteria.

A proportional anticipatory strategy should be taken with the following conditions: a zone with a large area, varied occupancy, and equipment that cannot exceed the required ventilation rate at design conditions. Exceeding the required ventilation rate means the equipment can condition air at a maximum ventilation rate that is greater than the required ventilation rate for maximum occupancy. A proportional-anticipatory strategy will cause the fresh air supplied to increase as the room CO₂ level increases even though the CO₂ set point has not been reached. By the time the CO₂ level reaches the set point, the damper will be at maximum ventilation and should maintain the set point.

In order to have the CO₂ sensor control the economizer damper in this manner, first determine the damper voltage output for minimum or base ventilation. Base ventilation is the ventilation required to remove contaminants during unoccupied periods. The following equation may be used to determine the percent of outside-air entering the building for a given damper position. For best results there should be at least a 10 degree difference in outside and return-air temperatures.

$$(T_O \times \frac{OA}{100}) + (T_R \times \frac{RA}{100}) = T_M$$

- T_O = Outdoor-Air Temperature
- OA = Percent of Outdoor Air
- T_R = Return-Air Temperature
- RA = Percent of Return Air
- T_M = Mixed-Air Temperature

Once base ventilation has been determined, set the minimum damper position potentiometer to the correct position.

The same equation can be used to determine the occupied or maximum ventilation rate to the building. For example, an output of 3.6 volts to the actuator provides a base ventilation rate of 5% and an output of 6.7 volts provides the maximum ventilation rate of 20% (or base plus 15 cfm per person). Use Fig. 40 to determine the maximum setting of the CO₂ sensor. For example, a 1100 ppm set point relates to a 15 cfm per person design. Use the 1100 ppm curve on Fig. 40 to find the point when the CO₂ sensor output will be 6.7 volts. Line up the point on the graph with the left side of the chart to determine that the range configuration for the CO₂ sensor should be 1800 ppm. The EconoMi\$erIV controller will output the 6.7 volts from the CO₂ sensor to the actuator when the CO₂ concentration in the space is at 1100 ppm. The DCV set point may be left at 2 volts

since the CO₂ sensor voltage will be ignored by the EconoMi\$erIV controller until it rises above the 3.6 volt setting of the minimum position potentiometer.

Once the fully occupied damper position has been determined, set the maximum damper demand control ventilation potentiometer to this position. Do not set to the maximum position as this can result in over-ventilation to the space and potential high-humidity levels.

CO₂ Sensor Configuration — The CO₂ sensor has preset standard voltage settings that can be selected anytime after the sensor is powered up. See Table 11.

Use setting 1 or 2 for Carrier equipment. See Table 11.

1. Press Clear and Mode buttons. Hold at least 5 seconds until the sensor enters the Edit mode.
2. Press Mode twice. The STDSET Menu will appear.
3. Use the Up/Down button to select the preset number. See Table 11.
4. Press Enter to lock in the selection.
5. Press Mode to exit and resume normal operation.

The custom settings of the CO₂ sensor can be changed anytime after the sensor is energized. Follow the steps below to change the non-standard settings:

1. Press Clear and Mode buttons. Hold at least 5 seconds until the sensor enters the Edit mode.
2. Press Mode twice. The STDSET Menu will appear.
3. Use the Up/Down button to toggle to the NONSTD menu and press Enter.
4. Use the Up/Down button to toggle through each of the nine variables, starting with Altitude, until the desired setting is reached.
5. Press Mode to move through the variables.
6. Press Enter to lock in the selection, then press Mode to continue to the next variable.

Dehumidification of Fresh Air with DCV Control — Information from ASHRAE indicates that the largest humidity load on any zone is the fresh air introduced. For some applications, a field-supplied energy recovery unit can be added to reduce the moisture content of the fresh air being brought into the building when the enthalpy is high. In most cases, the normal heating and cooling processes are more than adequate to remove the humidity loads for most commercial applications.

If normal rooftop heating and cooling operation is not adequate for the outdoor humidity level, an energy recovery unit and/or a dehumidification option should be considered.

Table 11 — CO₂ Sensor Standard Settings

SETTING	EQUIPMENT	OUTPUT	VENTILATION RATE (cfm/Person)	ANALOG OUTPUT	CO ₂ CONTROL RANGE (ppm)	OPTIONAL RELAY SETPOINT (ppm)	RELAY HYSTERESIS (ppm)
1	Interface w/Standard Building Control System	Proportional	Any	0-10V 4-20 mA	0-2000	1000	50
2		Proportional	Any	2-10V 7-20 mA	0-2000	1000	50
3		Exponential	Any	0-10V 4-20 mA	0-2000	1100	50
4	Economizer	Proportional	15	0-10V 4-20 mA	0-1100	1100	50
5		Proportional	20	0-10V 4-20 mA	0- 900	900	50
6		Exponential	15	0-10V 4-20 mA	0-1100	1100	50
7		Exponential	20	0-10V 4-20 mA	0- 900	900	50
8	Health & Safety	Proportional	—	0-10V 4-20 mA	0-9999	5000	500
9	Parking/Air Intakes/ Loading Docks	Proportional	—	0-10V 4-20 mA	0-2000	700	50

LEGEND

ppm — Parts Per Million

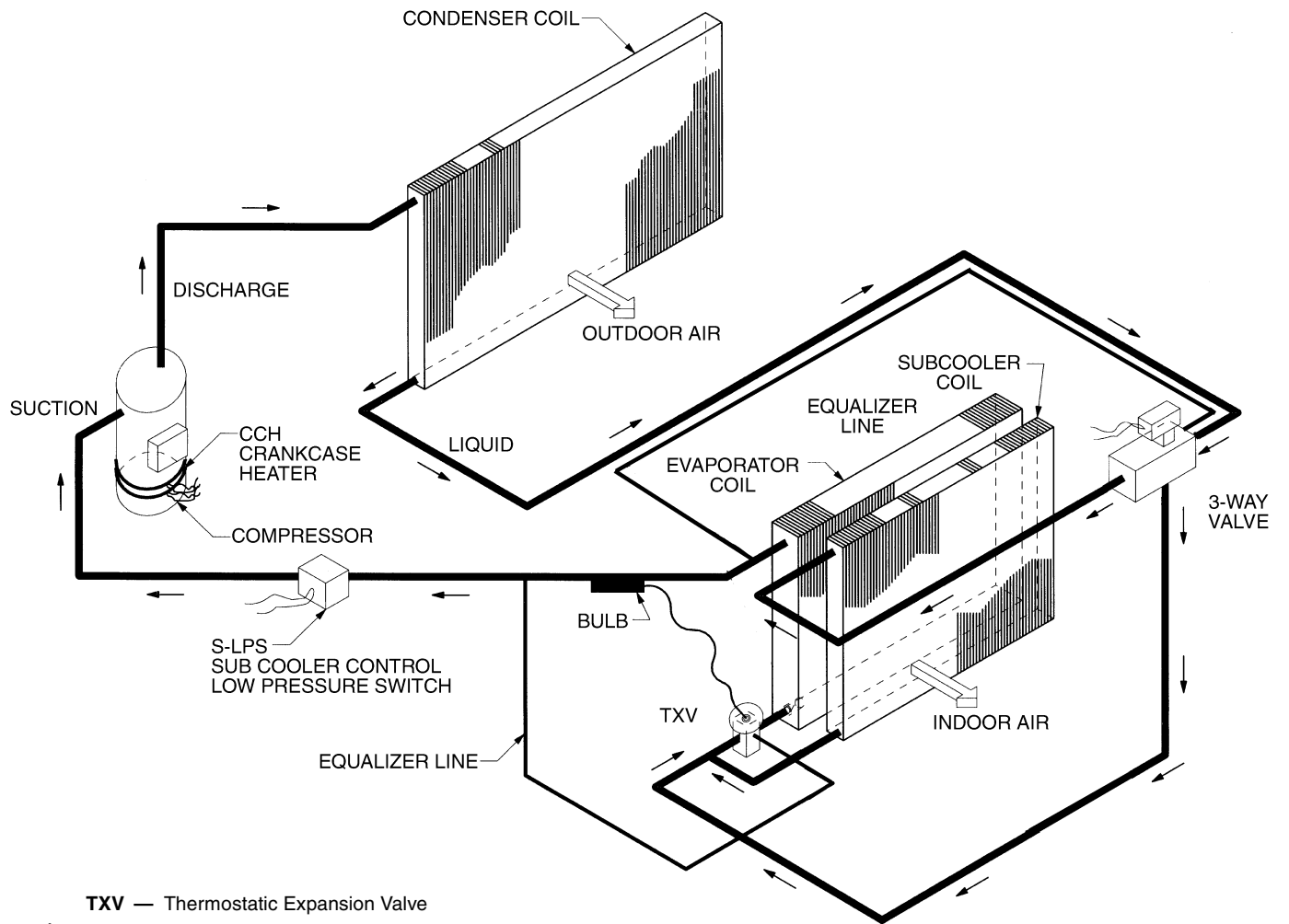

Fig. 43 — MoistureMiSer™ Operation Diagram

START-UP

Use the following information and Start-Up Checklist on page CL-1 to check out unit PRIOR to start-up.

Unit Preparation — Check that unit has been installed in accordance with these installation instructions and all applicable codes.

INTERNAL WIRING — Check all electrical connections in unit control boxes; tighten as required.

CRANKCASE HEATER — Heater is energized as long as there is power to unit and compressor is not operating.

IMPORTANT: Unit power must be on for 24 hours prior to start-up. Otherwise, damage to compressor may result.

COMPRESSOR MOUNTING — Compressors are internally spring mounted. Do not loosen or remove compressor hold-down bolts.

REFRIGERANT SERVICE PORTS — Each refrigerant system has a total of 3 Schrader-type service gage ports. One port is located on the suction line, one on the compressor discharge line, and one on the liquid line. In addition Schrader-type valves are located underneath the low-pressure switches. Be sure that caps on the ports are tight.

COMPRESSOR ROTATION — It is important to be certain the compressors are rotating in the proper direction. To determine whether or not compressors are rotating in the proper direction:

1. Connect service gages to suction and discharge pressure fittings.
2. Energize the compressor.
3. The suction pressure should drop and the discharge pressure should rise, as is normal on any start-up.

If the suction pressure does not drop and the discharge pressure does not rise to normal levels:

1. Note that the evaporator fan is probably also rotating in the wrong direction.
2. Turn off power to the unit.

3. Reverse any two of the incoming power leads.
4. Turn on power to the compressor.

The suction and discharge pressure levels should now move to their normal start-up levels.

NOTE: When compressors are rotating in the wrong direction, the unit will have increased noise levels and will not provide heating and cooling.

After a few minutes of reverse operation, the scroll compressor internal overload protection will open, which will activate the unit's lockout and requires a manual reset. Reset is accomplished by turning the thermostat on and off.

EVAPORATOR FAN — Fan belt and variable pulleys are factory installed. Remove tape from the fan pulley. See Table 12 for air quantity limits. See Tables 13-16 for fan performance data. Be sure that fans rotate in the proper direction. See Table 17 for static pressure information for accessories and options. See Table 18 for fan rpm at various fan motor pulley settings. See Tables 19 and 20 for evaporator fan motor data. To alter fan performance, see Evaporator-Fan Performance Adjustment section, page 37.

Table 12 — Air Quantity Limits

UNIT 50TM	MINIMUM CFM	MAXIMUM CFM
016	4500	7,500
020	5400	9,000
025	6000	10,000
028	7000	11,250

CONDENSER FANS AND MOTORS — Fans and motors are factory set. Refer to Condenser-Fan Adjustment section (page 38) as required.

RETURN-AIR FILTERS — Check that correct filters are installed in filter tracks. See Table 1. Do not operate unit without return-air filters.

OUTDOOR-AIR INLET SCREENS — Outdoor-air inlet screens must be in place before operating unit.

Table 13 — Fan Performance — 50TM016*

AIRFLOW (Cfm)	AVAILABLE EXTERNAL STATIC PRESSURE (in. wg)														
	0.2			0.4			0.6			0.8			1.0		
	Rpm	Watts	Bhp	Rpm	Watts	Bhp	Rpm	Watts	Bhp	Rpm	Watts	Bhp	Rpm	Watts	Bhp
4500	753	1307	1.53	753	1307	1.53	784	1397	1.64	859	1635	1.92	928	1880	2.20
4800	747	1384	1.62	747	1384	1.62	806	1563	1.83	878	1808	2.12	946	2060	2.42
5100	741	1465	1.72	752	1500	1.76	828	1745	2.05	898	1996	2.34	964	2255	2.65
5700	735	1659	1.95	805	1895	2.22	876	2156	2.53	942	2423	2.84	1004	2696	3.16
6000	759	1854	2.18	832	2118	2.48	901	2388	2.80	965	2663	3.12	1026	2943	3.45
6300	790	2088	2.45	860	2360	2.77	926	2638	3.09	988	2920	3.43	1048	3208	3.76
6600	821	2340	2.74	888	2621	3.07	952	2906	3.41	1013	3196	3.75	1070	3491	4.10
6900	852	2611	3.06	917	2900	3.40	979	3194	3.75	1038	3492	4.10	1094	3794	4.45
7200	883	2903	3.40	946	3200	3.75	1006	3501	4.11	1063	3807	4.47	1118	4117	4.83
7500	914	3215	3.77	975	3521	4.13	1033	3830	4.49	1089	4143	4.86	1142	4461	5.23

AIRFLOW (Cfm)	AVAILABLE EXTERNAL STATIC PRESSURE (in. wg)														
	1.2			1.4			1.6			1.8			2.0		
	Rpm	Watts	Bhp	Rpm	Watts	Bhp	Rpm	Watts	Bhp	Rpm	Watts	Bhp	Rpm	Watts	Bhp
4500	993	2133	2.50	1055	2394	2.81	1114	2662	3.12	1170	2938	3.45	1224	3220	3.78
4800	1009	2319	2.72	1070	2585	3.03	1127	2859	3.35	1183	3139	3.68	1236	3427	4.02
5100	1026	2521	2.96	1086	2794	3.28	1142	3073	3.60	1196	3359	3.94	1248	3650	4.28
5700	1064	2975	3.49	1120	3260	3.82	1174	3551	4.17	1226	3848	4.51	1277	4151	4.87
6000	1083	3228	3.79	1139	3520	4.13	1192	3817	4.48	1243	4119	4.83	1292	4427	5.19
6300	1104	3501	4.11	1158	3799	4.46	1210	4102	4.81	1260	4410	5.17	1309	4724	5.54
6600	1125	3791	4.45	1178	4095	4.80	1229	4405	5.17	1278	4720	5.54	1326	5039	5.91
6900	1147	4101	4.81	1199	4412	5.18	1249	4728	5.55	1297	5050	5.92	—	—	—
7200	1170	4431	5.20	1221	4749	5.57	1270	5072	5.95	—	—	—	—	—	—
7500	1193	4781	5.61	1243	5107	5.99	—	—	—	—	—	—	—	—	—

AIRFLOW (Cfm)	AVAILABLE EXTERNAL STATIC PRESSURE (in. wg)																	
	2.2			2.4			2.6			2.8			3.0			3.2		
	Rpm	Watts	Bhp	Rpm	Watts	Bhp	Rpm	Watts	Bhp	Rpm	Watts	Bhp	Rpm	Watts	Bhp	Rpm	Watts	Bhp
4500	1276	3509	4.12	1326	3805	4.46	1375	4107	4.82	1421	4414	5.18	1467	4728	5.55	1511	5047	5.92
4800	1287	3721	4.36	1336	4020	4.72	1384	4326	5.07	1430	4638	5.44	1475	4955	5.81	—	—	—
5100	1299	3949	4.63	1347	4253	4.99	1395	4563	5.35	1440	4879	5.72	—	—	—	—	—	—
5700	1325	4458	5.23	1373	4772	5.60	1418	5091	5.97	—	—	—	—	—	—	—	—	—
6000	1340	4741	5.56	1387	5060	5.93	—	—	—	—	—	—	—	—	—	—	—	—
6300	1356	5043	5.91	—	—	—	—	—	—	—	—	—	—	—	—	—	—	—
6600	—	—	—	—	—	—	—	—	—	—	—	—	—	—	—	—	—	—
6900	—	—	—	—	—	—	—	—	—	—	—	—	—	—	—	—	—	—
7200	—	—	—	—	—	—	—	—	—	—	—	—	—	—	—	—	—	—
7500	—	—	—	—	—	—	—	—	—	—	—	—	—	—	—	—	—	—

LEGEND

Bhp — Brake Horsepower
Watts — Input Watts to Motor

NOTES:

1. Maximum continuous bhp for the standard motor is 6.13. The maximum continuous watts is 5180. Do not adjust motor rpm such that motor maximum bhp and/or watts is exceeded at the maximum operating cfm.
2. See page 33 for general fan performance notes.

*Standard low-medium static drive range is 873 to 1021 rpm. Alternate high-static drive range is 1025 to 1200. Other rpms require a field-supplied drive.

Table 14 — Fan Performance — 50TM020*

AIRFLOW (Cfm)	AVAILABLE EXTERNAL STATIC PRESSURE (in. wg)																	
	0.2			0.4			0.6			0.8			1.0			1.2		
	Rpm	Bhp	Watts	Rpm	Bhp	Watts	Rpm	Bhp	Watts	Rpm	Bhp	Watts	Rpm	Bhp	Watts	Rpm	Bhp	Watts
5,500	682	1.99	1675	760	2.29	1922	832	2.59	2177	901	2.90	2441	965	3.22	2712	1027	3.56	2990
6,000	730	2.38	2005	802	2.68	2257	871	2.99	2516	935	3.31	2783	997	3.63	3057	1056	3.97	3337
6,500	778	2.82	2373	846	3.13	2630	911	3.44	2893	972	3.76	3164	1031	4.09	3440	1087	4.43	3722
7,000	828	3.31	2780	892	3.62	3042	953	3.94	3310	1011	4.26	3583	1067	4.59	3863	1121	4.93	4148
7,500	878	3.84	3227	938	4.15	3494	996	4.48	3766	1051	4.81	4043	1105	5.14	4326	1156	5.49	4613
8,000	928	4.42	3715	985	4.74	3986	1040	5.07	4263	1093	5.40	4544	1144	5.74	4830	1194	6.09	5120
8,500	979	5.05	4245	1033	5.38	4521	1085	5.71	4801	1136	6.05	5086	1185	6.39	5375	1232	6.74	5669
9,000	1030	5.73	4817	1082	6.06	5098	1131	6.40	5382	1180	6.74	5671	1227	7.09	5964	1272	7.44	6260
9,500	1082	6.46	5433	1131	6.80	5718	1178	7.14	6007	1225	7.49	6299	1270	7.84	6595	1313	8.20	6895
10,000	1134	7.25	6093	1180	7.59	6382	1226	7.94	6675	1270	8.29	6971	1313	8.65	7271	1356	9.01	7574

AIRFLOW (Cfm)	AVAILABLE EXTERNAL STATIC PRESSURE (in. wg)														
	1.4			1.6			1.8			1.9			2.0		
	Rpm	Bhp	Watts	Rpm	Bhp	Watts	Rpm	Bhp	Watts	Rpm	Bhp	Watts	Rpm	Bhp	Watts
5,500	1086	3.89	3275	1142	4.24	3567	1197	4.59	3864	1223	4.77	4015	1249	4.96	4167
6,000	1112	4.31	3623	1167	4.66	3915	1219	5.01	4213	1245	5.19	4364	1270	5.37	4516
6,500	1142	4.77	4010	1194	5.12	4304	1245	5.47	4602	1270	5.65	4754	1294	5.83	4906
7,000	1173	5.28	4438	1224	5.63	4733	1273	5.98	5033	1296	6.17	5184	1320	6.35	5337
7,500	1207	5.83	4906	1255	6.19	5203	1302	6.55	5504	1326	6.73	5657	1348	6.91	5810
8,000	1242	6.44	5415	1289	6.80	5714	1334	7.16	6018	1357	7.34	6171	1379	7.52	6325
8,500	1279	7.10	5966	1324	7.45	6268	1368	7.82	6573	1389	8.00	6728	1411	8.18	6883
9,000	1317	7.80	6561	1360	8.16	6865	1403	8.53	7173	1424	8.71	7328	1445	8.90	7484
9,500	1356	8.56	7198	1398	8.93	7505	1440	9.29	7815	1460	9.48	7972	1480	9.67	8129
10,000	1397	9.37	7881	1438	9.74	8190	1477	10.11	8503	—	—	—	—	—	—

LEGEND

Bhp — Brake Horsepower
Watts — Input Watts to Motor

NOTES:

1. Maximum continuous bhp is 5.90. The maximum continuous watts is 5180. Do not adjust motor rpm such that motor maximum bhp and/or watts is exceeded at the maximum operating cfm.
2. See page 33 for general fan performance notes.

*Standard low-medium static drive range is 910 to 1095 rpm. Alternate high-static drive range is 1069 to 1287 rpm. Other rpms require a field-supplied drive.

Table 15 — Fan Performance — 50TM025*

AIRFLOW (Cfm)	AVAILABLE EXTERNAL STATIC PRESSURE (in. wg)														
	0.2			0.4			0.6			0.8			1.0		
	Rpm	Watts	Bhp	Rpm	Watts	Bhp	Rpm	Watts	Bhp	Rpm	Watts	Bhp	Rpm	Watts	Bhp
6,000	753	2385	2.83	816	2579	3.06	884	2807	3.33	949	3040	3.61	1010	3277	3.89
6,500	793	2738	3.25	861	2959	3.51	925	3186	3.78	987	3418	4.05	1045	3653	4.33
7,000	844	3151	3.74	908	3372	4.00	968	3598	4.27	1026	3828	4.54	1082	4062	4.82
7,500	895	3596	4.27	955	3817	4.53	1013	4042	4.80	1068	4271	5.07	1121	4504	5.34
8,000	947	4073	4.83	1004	4294	5.09	1058	4518	5.36	1111	4747	5.63	1162	4978	5.91
8,500	999	4583	5.44	1053	4803	5.70	1105	5027	5.96	1155	5255	6.23	1204	5485	6.51
9,000	1052	5125	6.08	1103	5345	6.34	1152	5569	6.61	1200	5796	6.88	1247	6025	7.15
9,500	1105	5699	6.76	1153	5919	7.02	1200	6142	7.29	1246	6369	7.56	1291	6598	7.83
10,000	1158	6306	7.48	1204	6526	7.74	1249	6750	8.01	1293	6975	8.27	1336	7203	8.55

AIRFLOW (Cfm)	AVAILABLE EXTERNAL STATIC PRESSURE (in. wg)														
	1.2			1.4			1.6			1.8			2.0		
	Rpm	Watts	Bhp	Rpm	Watts	Bhp	Rpm	Watts	Bhp	Rpm	Watts	Bhp	Rpm	Watts	Bhp
6,000	1069	3517	4.17	1125	3761	4.46	1180	4006	4.75	1232	4255	5.05	1283	4506	5.35
6,500	1102	3891	4.62	1156	4132	4.90	1208	4377	5.19	1259	4623	5.48	1308	4871	5.78
7,000	1136	4299	5.10	1188	4538	5.38	1239	4780	5.67	1288	5025	5.96	1335	5271	6.25
7,500	1173	4739	5.62	1223	4977	5.90	1272	5217	6.19	1319	5460	6.48	1365	5705	6.77
8,000	1211	5212	6.18	1259	5449	6.46	1306	5688	6.75	1352	5929	7.03	1396	6172	7.32
8,500	1251	5718	6.78	1297	5954	7.06	1342	6192	7.35	1386	6431	7.63	1429	6673	7.92
9,000	1292	6257	7.42	1337	6492	7.70	1380	6729	7.98	1423	6967	8.27	1464	7207	8.55
9,500	1335	6830	8.10	1377	7063	8.38	1419	7299	8.66	1460	7536	8.94	1501	7776	9.22
10,000	1378	7434	8.82	1419	7667	9.10	1460	7902	9.37	1499	8138	9.65	1538	8377	9.94

AIRFLOW (Cfm)	AVAILABLE EXTERNAL STATIC PRESSURE (in. wg)														
	2.2			2.4			2.6			2.8			3.0		
	Rpm	Watts	Bhp	Rpm	Watts	Bhp	Rpm	Watts	Bhp	Rpm	Watts	Bhp	Rpm	Watts	Bhp
6,000	1332	4750	5.65	1380	5015	5.95	1427	5272	6.25	1472	5531	6.56	1517	5793	6.87
6,500	1356	5122	6.08	1402	5375	6.38	1447	5630	6.68	1492	5886	6.98	1535	6144	7.29
7,000	1381	5519	6.55	1427	5770	6.84	1471	6022	7.14	1514	6276	7.45	—	—	—
7,500	1409	5951	7.06	1453	6199	7.35	1496	6449	7.65	1538	6701	7.95	—	—	—
8,000	1440	6417	7.61	1482	6663	7.90	1523	6911	8.20	—	—	—	—	—	—
8,500	1471	6916	8.20	1513	7161	8.49	—	—	—	—	—	—	—	—	—
9,000	1505	7449	8.84	1545	7693	9.13	—	—	—	—	—	—	—	—	—
9,500	1540	8016	9.51	—	—	—	—	—	—	—	—	—	—	—	—
10,000	—	—	—	—	—	—	—	—	—	—	—	—	—	—	—

LEGEND

Bhp — Brake Horsepower
Watts — Input Watts to Motor

NOTES:

1. Maximum continuous bhp for the standard motor is 8.7 (for 208/230 and 575-v units) and 9.5 (for 460-v units). The maximum continuous watts is 7915 (for 208/230 and 575-v units) and 8640 (for 230 and 460-v units). Do not adjust motor rpm such that motor maximum bhp and/or watts is exceeded at the maximum operating cfm.
2. See page 33 for general fan performance notes.

*Standard low-medium static drive range is 1002 to 1151 rpm. Alternate high-static drive range is 1193 to 1369. Other rpms require a field-supplied drive.

Table 16 — Fan Performance — 50TM028*

AIRFLOW (Cfm)	AVAILABLE EXTERNAL STATIC PRESSURE (in. wg)																	
	0.2			0.4			0.6			0.8			1.0			1.2		
	Rpm	Bhp	Watts	Rpm	Bhp	Watts	Rpm	Bhp	Watts	Rpm	Bhp	Watts	Rpm	Bhp	Watts	Rpm	Bhp	Watts
7,000	845	3.26	2693	909	3.60	2979	969	3.96	3272	1028	4.32	3574	1083	4.70	3883	1137	5.08	4,200
7,500	896	3.82	3156	956	4.17	3450	1014	4.54	3752	1069	4.91	4060	1123	5.29	4375	1174	5.68	4,698
8,000	948	4.43	3667	1005	4.80	3969	1060	5.17	4278	1112	5.56	4593	1163	5.94	4915	1213	6.34	5,243
8,500	1001	5.11	4226	1054	5.49	4537	1106	5.87	4853	1156	6.26	5175	1205	6.66	5504	1253	7.06	5,838
9,000	1053	5.85	4836	1104	6.23	5155	1154	6.63	5478	1202	7.02	5808	1248	7.43	6142	1294	7.84	6,483
9,500	1106	6.65	5498	1155	7.04	5824	1202	7.44	6155	1248	7.85	6492	1293	8.26	6833	1336	8.68	7,179
10,000	1159	7.52	6214	1206	7.92	6547	1251	8.33	6886	1295	8.74	7229	1338	9.16	7577	1380	9.59	7,929
10,500	1213	8.45	6984	1257	8.86	7325	1300	9.28	7671	1342	9.70	8020	1384	10.13	8375	1424	10.56	8,733
11,000	1266	9.45	7810	1309	9.87	8159	1350	10.29	8511	1391	10.73	8868	1431	11.16	9229	1470	11.60	9,594
11,250	1293	9.97	8245	1334	10.40	8597	1375	10.83	8953	1415	11.26	9313	1454	11.70	9677	1493	12.15	10,045

AIRFLOW (Cfm)	AVAILABLE EXTERNAL STATIC PRESSURE (in. wg)								
	1.4			1.6			1.8		
	Rpm	Bhp	Watts	Rpm	Bhp	Watts	Rpm	Bhp	Watts
7,000	1189	5.47	4,524	1239	5.87	4,854	1288	4.91	5191
7,500	1224	6.08	5,026	1272	6.48	5,362	1320	5.56	5703
8,000	1261	6.75	5,577	1307	7.16	5,917	1353	6.26	6263
8,500	1299	7.47	6,177	1344	7.89	6,523	1388	7.02	6873
9,000	1338	8.26	6,828	1382	8.68	7,179	1424	7.85	7534
9,500	1379	9.11	7,530	1421	9.54	7,887	1462	8.74	8247
10,000	1421	10.02	8,286	1461	10.46	8,648	1501	9.70	9014
10,500	1464	11.00	9,096	1503	11.45	9,464	1541	10.73	9835
11,000	1508	12.05	9,963	1546	12.50	10,336	—	—	—
11,250	1530	12.60	10,417	—	—	—	—	—	—

LEGEND

Bhp — Brake Horsepower
Watts — Input Watts to Motor

*Standard low-medium static drive range is 1066 to 1283 rpm. Alternate high-static drive range is 1332 to 1550. Other rpms require a field-supplied drive.

Refer to this page for general Fan Performance Data notes.

NOTE: Maximum continuous bhp is 10.20 (208/230, 575 v) or 11.80 (460 v) and the maximum continuous watts are 9510 (208/230, 575 v) or 11,000 (460 v). Do not adjust motor rpm such that motor maximum bhp and/or watts is exceeded at the maximum operating cfm. See Evaporator Fan Motor Data tables for more information.

GENERAL FAN PERFORMANCE NOTES

NOTES:

- Values include losses for filters, unit casing, and wet coils. See Table 17 for accessory/factory-installed option static pressure information.
- Extensive motor and electrical testing on these units ensures that the full range of the motor can be utilized with confidence. Using fan motors up to the wattage ratings shown will not result

- in nuisance tripping or premature motor failure. Unit warranty will not be affected. See Evaporator-Fan Motor Performance data in Table 19 on page 34 for additional information.
- Use of a field-supplied motor may affect wire sizing. Contact your Carrier representative for details.
- Interpolation is permissible. Do not extrapolate.

Table 17 — Accessory/FIOP Static Pressure (in. wg) — 50TM016-028

COMPONENT	CFM					
	5400	6000	7200	9000	10,000	11,250
Economizer	0.06	0.07	0.09	0.11	0.12	0.14
Glycol Coil	0.30	0.35	0.44	0.58	0.66	0.77
Electric Heat (kW)						
26/34	0.08	0.09	0.11	0.15	0.17	0.20
32	0.08	0.09	0.11	0.15	0.17	0.20
42/56	0.11	0.12	0.15	0.19	0.21	0.24
55	0.11	0.12	0.15	0.19	0.21	0.24
56/75	0.14	0.15	0.20	0.24	0.26	0.29
80	0.14	0.15	0.20	0.24	0.26	0.29
MoistureMiSer™ Dehumidification	0.06	0.07	0.10	0.16	0.20	0.25

LEGEND

FIOP — Factory-Installed Option

NOTES:

- The static pressure must be added to external static pressure. The sum and the evaporator entering-air cfm should then be used in conjunction with the Fan Performance tables to determine blower rpm and watts.
- Heaters are rated at 240 v and 480 v. There are no 575-v heaters.

Table 18 — Fan Rpm at Motor Pulley Settings*

UNIT 50TM	MOTOR PULLEY TURNS OPEN												
	0	1/2	1	1 1/2	2	2 1/2	3	3 1/2	4	4 1/2	5	5 1/2	6
016†	††	††	††	††	1021	1002	984	965	947	928	910	891	873
016**	††	††	††	††	1200	1178	1156	1134	1112	1091	1069	1047	1025
020†	††	††	1095	1077	1058	1040	1021	1002	984	965	947	928	910
020**	††	††	1287	1265	1243	1222	1200	1178	1156	1134	1112	1091	1069
025†	††	††	††	††	1151	1132	1114	1095	1077	1058	1040	1021	1002
025**	††	††	††	††	1369	1347	1325	1303	1281	1259	1237	1215	1193
028†	††	††	1283	1269	1247	1225	1203	1182	1160	1138	1116	1095	1066
028**	††	††	—	—	1551	1524	1497	1470	1443	1415	1388	1361	1332

*Approximate fan rpm shown.
†Indicates standard drive package.
**Indicates alternate drive package.
††Due to belt and pulley size, pulley cannot be set to this number of turns open.

Table 19 — Evaporator-Fan Motor Performance

UNIT 50TM	UNIT VOLTAGE	MAXIMUM ACCEPTABLE CONTINUOUS BHP*	MAXIMUM ACCEPTABLE CONTINUOUS BkW*	MAXIMUM ACCEPTABLE OPERATING WATTS	MAXIMUM AMP DRAW
016	208/230	6.13	4.57	5,180	15.8
	460	6.13	4.57	5,180	7.9
	575	6.13	4.57	5,180	6.0
020	208/230	5.90	4.40	5,180	15.8
	460	5.90	4.40	5,180	7.9
	575	5.90	4.40	5,180	6.0
025	208/230	8.70	6.49	7,915	22.0
	460	9.50	7.08	8,640	13.0
	575	8.70	6.49	7,915	10.0
028	208/230	10.20	7.61	9,510	28.0
	460	11.80	8.80	11,000	14.6
	575	10.20	7.61	9,510	13.0

LEGEND

BHP — Brake Horsepower
BkW — Brake Kilowatts

*Extensive motor and electrical testing on these units ensures that the full horsepower (brake kilowatt) range of the motors can be utilized with confidence. Using your fan motors up to the horsepower (brake kilowatt) ratings shown in this table will not result in nuisance tripping or premature motor failure. Unit warranty will not be affected.

NOTE: All indoor-fan motors 5 hp and larger meet the minimum efficiency requirements as established by the Energy Policy Act of 1992 (EPACT) effective October 24, 1997.

Table 20 — Evaporator-Fan Motor Efficiency

MOTOR HORSEPOWER	MOTOR EFFICIENCY (%)
5 Hp	87.5
7.5 Hp	88.5
10 Hp	89.5

NOTE: All indoor-fan motors 5 hp and larger meet the minimum efficiency requirements as established by the Energy Policy Act of 1992 (EPACT) effective October 24, 1997.

Operating Sequence

COOLING, UNITS WITHOUT ECONOMIZER — When thermostat calls for cooling, terminals G and Y1 are energized. The indoor (evaporator) fan contactor (IFC), outdoor fan contactor (OFC), and compressor contactor no. 1 (C1) are energized and evaporator-fan motor, condenser fans and compressor no. 1 start. The condenser-fan motors run continuously while unit is cooling. If the thermostat calls for a second stage of cooling by energizing Y2, compressor contactor no. 2 (C2) is energized and compressor no. 2 starts.

HEATING, UNITS WITHOUT ECONOMIZER (If Optional or Accessory Heater is Installed) — Upon a call for heating through terminal W1, IFC and heater contactor no. 1 (HC1) are energized. On units equipped for 2 stages of heat, when additional heat is needed HC2 is energized through W2.

COOLING, UNITS WITH ECONOMIZER — When free cooling is not available, the compressors will be controlled by the zone thermostat. When free cooling is available, the outdoor-air damper is modulated by the EconoMi\$erIV control to provide a 50 to 55 F supply-air temperature into the zone. As the supply-air temperature fluctuates above 55 or below 50 F, the dampers will be modulated (open or close) to bring the supply-air temperature back within set point limits.

For EconoMi\$erIV operation, there must be a thermostat call for the fan (G). This will move the damper to its minimum position during the occupied mode.

Above 50 F supply-air temperature, the dampers will modulate from 100% open to the minimum open position. From 50 F to 45 F supply-air temperature, the dampers will maintain at the minimum open position. Below 45 F the dampers will be completely shut. As the supply-air temperature rises, the dampers will come back open to the minimum open position once the supply-air temperature rises to 48 F.

If optional power exhaust is installed, as the outdoor-air damper opens and closes, the power exhaust fans will be energized and deenergized.

If field-installed accessory CO₂ sensors are connected to the EconoMi\$erIV control, a demand controlled ventilation strategy will begin to operate. As the CO₂ level in the zone increases above the CO₂ set point, the minimum position of the damper will be increased proportionally. As the CO₂ level decreases because of the increase in fresh air, the outdoor-air damper will be proportionally closed. Damper position will follow the higher demand condition from DCV mode or free cooling mode.

Damper movement from full closed to full open (or vice versa) will take between 1½ and 2½ minutes.

If free cooling can be used as determined from the appropriate changeover command (switch, dry bulb, enthalpy curve, differential dry bulb, or differential enthalpy), a call for cooling (Y1 closes at the thermostat) will cause the control to modulate the dampers open to maintain the supply air temperature set point at 50 to 55 F.

As the supply-air temperature drops below the set point range of 50 to 55 F, the control will modulate the outdoor-air dampers closed to maintain the proper supply-air temperature.

HEATING, UNITS WITH ECONOMIZER — When the room thermostat calls for heat, the heating controls are energized as described in the Heating, Units Without Economizer section. When the indoor fan is energized, the economizer damper moves to the minimum position. When the indoor fan is off, then the economizer damper is fully closed.

COOLING, UNITS WITH ECONOMIZER2, PREMIER-LINK™ CONTROL AND A THERMOSTAT — When free cooling is not available, the compressors will be controlled by the PremierLink control in response to the Y1 and Y2 inputs from the thermostat.

The PremierLink control will use the following information to determine if free cooling is available:

- Indoor fan has been on for at least 30 seconds.
- The SPT, SAT, and OAT inputs must have valid readings.
- OAT must be less than 75 F.
- OAT must be less than SPT.
- Enthalpy must be LOW (may be jumpered if an enthalpy sensor not available).
- Economizer position is NOT forced.

Pre-cooling occurs when there is no call from the thermostat except G. Pre-cooling is defined as the economizer modulates to provide 70 F supply air.

When free cooling is available the PremierLink control will control the compressors, energize the reversing valve(s) and economizer to provide a supply-air temperature determined to meet the Y1 and Y2 calls from the thermostat using the following three routines. The three control routines are based on OAT.

The 3 routines are based on OAT where:

SASP = Supply Air Set Point

DXCTLO = Direct Expansion Cooling Lockout Set Point

PID = Proportional Integral

Routine 1 (OAT < DXCTLO)

- Y1 energized – economizer maintains a SASP = (SATLO1 + 3).
- Y2 energized – economizer maintains a SASP = (SATLO2 + 3).

Routine 2 (DXCTLO < OAT < 68 F)

- If only Y1 energized, the economizer maintains a SASP = (SATLO1 + 3).
- If SAT > SASP + 5 and economizer position > 80%, economizer will go to minimum position for 3 minutes or until SAT > 68 F.
- First stage of mechanical cooling will be energized.
- Integrator resets.
- Economizer opens again and controls to current SASP after stage one on for 90 seconds.
- With Y1 and Y2 energized economizer maintains an SASP = SATLO2 + 3.
- If SAT > SASP + 5 and economizer position >80%, economizer will go to minimum position for 3 minutes or until SAT > 68 F.
- If compressor one is on then second stage of mechanical cooling will be energized. Otherwise the first stage will be energized.
- Integrator resets.
- Economizer opens again and controls to SASP after stage one on for 90 seconds.

Routine 3 (OAT > 68)

- Economizer is opened 100%.
- Compressors 1 and 2 are cycled based on Y1 and Y2 using minimum on and off times and watching the supply-air temperature as compared to SATLO1 and SATLO2 set points.

If optional power exhaust is installed, as the outdoor-air damper opens and closes, the power exhaust fans will be energized and deenergized.

If field-installed accessory CO₂ sensors are connected to the PremierLink control, a PID-controlled demand ventilation strategy will begin to operate. As the CO₂ level in the zone increases above the CO₂ set point, the minimum position of the damper will be increased proportionally. As the CO₂ level decreases because of the increase in fresh air, the outdoor-air damper will be proportionally closed.

HEATING, UNITS WITH ECONOMIZER2, PREMIERLINK CONTROL AND A THERMOSTAT — When the thermostat calls for heating, terminal W1 is energized. The PremierLink control will move the economizer damper to the minimum position if there is a call for G and closed if there is a call for W1 without G. In order to prevent thermostat from short cycling,

the unit is locked into the heating mode for at least 10 minutes when W1 is energized.

On units equipped for two stages of heat, when additional heat is needed, W2 is energized and the electric heat (if used) comes on. When the thermostat is satisfied and W1 is deenergized, the IFM stops.

COOLING, UNITS WITH ECONOMISER2, PREMIERLINK™ CONTROL AND A ROOM SENSOR — When free cooling is not available, the compressors will be controlled by the PremierLink controller using a PID Error reduction calculation as indicated by Fig 44.

The PremierLink controller will use the following information to determine if free cooling is available:

- Indoor fan has been on for at least 30 seconds.
- The SPT, SAT, and OAT inputs must have valid readings.
- OAT must be less than 75 F.
- OAT must be less than SPT.
- Enthalpy must be LOW (may be jumpered if and enthalpy sensor is not available).
- Economizer position is NOT forced.

When free cooling is available, the outdoor-air damper is positioned through the use of a Proportional Integral (PID) control process to provide a calculated supply-air temperature into the zone. The supply air will maintain the space temperature between the heating and cooling set points as indicated in Fig. 45.

The PremierLink control will integrate the compressors stages with the economizer based on similar logic as the three routines listed in the previous section. The SASP will float up and down based on the error reduction calculations that compare space temperature and space set point. The reversing valves will be energized.

When outdoor-air temperature conditions require the economizer to close for a compressor stage-up sequence, the economizer control integrator is reset to zero after the stage-up sequence is completed. This prevents the supply-air temperature from dropping too quickly and creating a freeze condition that would make the compressor turn off prematurely.

The high space set point is used for DX (direct expansion) cooling control, while the economizer space set point is a calculated value between the heating and cooling set points. The economizer set point will always be at least one degree below the cooling set point, allowing for a smooth transition from mechanical cooling with economizer assist, back to economizer cooling as the cooling set point is achieved. The compressors may be used for initial cooling then the PremierLink controller will modulate the economizer using an error reduction calculation to hold the space temperature between the heating and cooling set points. See Fig. 45.

The controller uses the following conditions to determine economizer cooling:

- Enthalpy is Low
- SAT reading is available
- OAT reading is available
- SPT reading is available
- $OAT \leq SPT$
- Economizer Position is NOT forced

If any of the above conditions are **not** met, the economizer submaster reference (ECSR) is set to maximum limit and the damper moves to minimum position. The operating sequence is complete. The ECSR is recalculated every 30 seconds.

If an optional power exhaust is installed, as the outdoor-air damper opens and closes, the power exhaust fans will be energized and deenergized.

If field-installed accessory CO₂ sensors are connected to the PremierLink control, a PID-controlled demand ventilation

strategy will begin to operate. As the CO₂ level in the zone increases above the CO₂ set point, the minimum position of the damper will be increased proportionally. As the CO₂ level decreases because of the increase in fresh air, the outdoor-air damper will be proportionally closed.

HEATING, UNIT WITH ECONOMISER2, PREMIERLINK CONTROL AND A ROOM SENSOR — Every 40 seconds the controller will calculate the required heat stages (maximum of 3) to maintain supply-air temperature (SAT) if the following qualifying conditions are met:

- Indoor fan has been on for at least 30 seconds.
- COOL mode is not active.
- OCCUPIED, TEMP.COMPENSATED START or HEAT mode is active.
- SAT reading is available.
- Fire shutdown mode is not active.

If all of the above conditions are met, the number of heat stages is calculated; otherwise the required number of heat stages will be set to 0.

If the PremierLink controller determines that heat stages are required, the economizer damper will be moved to minimum position if occupied and closed if unoccupied.

Staging should be as follows:

If Heating PID STAGES=2

- HEAT STAGES=1 (75% capacity) will energize HS1
- HEAT STAGES=2 (100% capacity) will energize HS2

In order to prevent short cycling, the unit is locked into the Heating mode for at least 10 minutes when HS1 is deenergized. On units equipped for two stages of heat, when additional heat is needed, it may be provided by electric heat (if supplied). When the space condition is satisfied and HS1 is deenergized the IFM stops. The fan will run continuously in the occupied mode as required by national energy and fresh air standards.

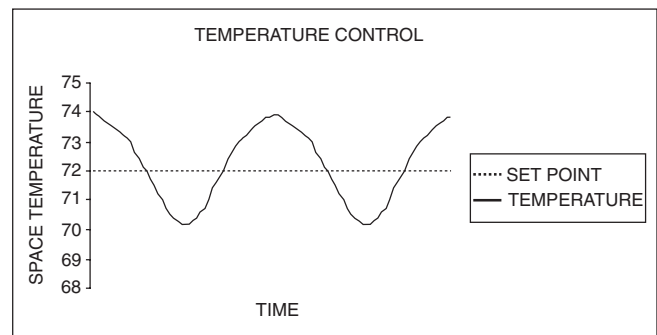

NOTE: PremierLink control performs smart staging of 2 stages of DX cooling and up to 3 stages of heat.

Fig. 44 — DX Cooling Temperature Control Example

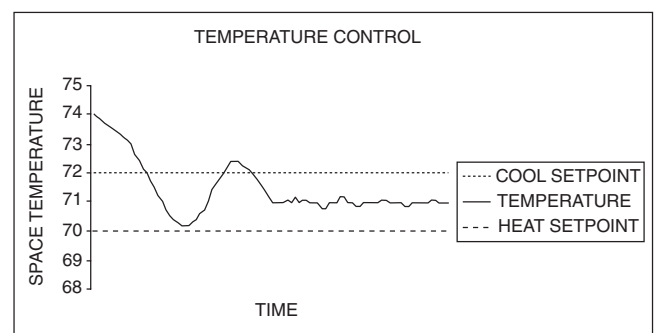

Fig. 45 — Economizer Temperature Control Example

SERVICE

⚠ WARNING

Before performing service or maintenance operations on unit, turn off main power switch to unit. Turn off accessory heater power switch if applicable. Electrical shock could cause personal injury.

Cleaning — Inspect unit interior at beginning of each heating and cooling season and as operating conditions require. Remove unit top panel and/or side panels for access to unit interior.

EVAPORATOR COIL — Clean as required with a commercial coil cleaner.

NOTE: The 50TM028 unit has a mist eliminator screen attached to the evaporator coil to prevent condensate runoff at high wet-bulb conditions. Check periodically and clean as necessary.

CONDENSER COIL — Clean condenser coil annually and as required by location and outdoor-air conditions. Inspect coil monthly — clean as required.

CONDENSATE DRAIN — Check and clean each year at start of cooling season.

FILTERS — Clean or replace at start of each heating and cooling season, or more often if operating conditions require. Refer to Table 1 for type and size.

NOTE: The 50TM028 unit requires industrial grade throw-away filters capable of withstanding face velocities up to 625 fpm. Ensure that replacement filters for the 50TM028 units are rated for 625 fpm.

OUTDOOR-AIR INLET SCREENS — Clean screens with steam or hot water and a mild detergent. Do not use throwaway filters in place of screens.

Lubrication

COMPRESSORS — Each compressor is charged with the correct amount of oil at the factory. Conventional white oil (Sontext 200LT) is used. White oil is compatible with 3GS oil, and 3GS oil may be used if the addition of oil is required. See compressor nameplate for original oil charge. A complete recharge should be four ounces less than the original oil charge. When a compressor is exchanged in the field it is possible that a major portion of the oil from the replaced compressor may still be in the system. While this will not affect the reliability of the replacement compressor, the extra oil will add rotor drag and increase power usage. To remove this excess oil, an access valve may be added to the lower portion of the suction line at the inlet of the compressor. The compressor should then be run for 10 minutes, shut down, and the access valve opened until no oil flows. This should be repeated twice to make sure the proper oil level has been achieved.

FAN SHAFT BEARINGS — The bearings are of the pillow block type and have grease fittings. The bearing opposite the motor end has an extended tube line so it can be lubricated from the motor side. Lubricate the bearings twice annually.

Typical lubricants are given below:

MANUFACTURER	LUBRICANT
Texaco	Regal AFB-2*
Mobil	Mobilplex EP No. 1
Sunoco	Prestige 42
Texaco	Multifak 2

*Preferred lubricant because it contains rust and oxidation inhibitors.

CONDENSER AND EVAPORATOR-FAN MOTOR BEARINGS — The condenser-fan and evaporator-fan motors have permanently sealed bearings, so no field lubrication is necessary.

Evaporator Fan Performance Adjustment (Fig. 46 and 47) — Fan motor pulleys are factory set for speed shown in Table 1.

To change fan speeds:

1. Shut off unit power supply.
2. Loosen nuts on the 2 carriage bolts in the motor mounting base. Install jacking bolt and plate under motor base (bolt and plate are shipped in installer's packet). See Fig. 47. Using bolt and plate, raise motor to top of slide and remove belt. Secure motor in this position by tightening the nuts on the carriage bolts.
3. Loosen movable-pulley flange setscrew (see Fig. 46).
4. Screw movable flange toward fixed flange to increase speed and away from fixed flange to decrease speed. Increasing fan speed increases load on motor. Do not exceed maximum speed specified in Table 1.

See Table 12 for air quantity limits.

5. Set movable flange at nearest keyway of pulley hub and tighten setscrew. (See Table 1 for speed change for each full turn of pulley flange.)
6. Replace and tighten belts. See Belt Tension Adjustment section on this page.

To align fan and motor pulleys:

1. Loosen fan pulley setscrews.
2. Slide fan pulley along fan shaft.
3. Make angular alignment by loosening motor from mounting plate.

Evaporator Fan Service and Replacement —

The 50TM020-028 units use a fan motor mounting system that features a slide-out motor mounting plate. To replace or service the motor, slide out the bracket. See Fig. 47.

1. Remove the evaporator-fan access panel and the heating control access panel.
2. Remove the center post (located between the evaporator fan and heating control access panels) and all screws securing it.
3. Loosen nuts on the two carriage bolts in the motor mounting base.
4. Using jacking bolt under motor base, raise motor to top of slide and remove belt. Secure motor in this position by tightening the nuts on the carriage bolts.
5. Remove the belt drive.
6. Remove jacking bolt and tapped jacking bolt plate.
7. Remove the 2 screws that secure the motor mounting plate to the motor support channel.
8. Remove the 3 screws from the end of the motor support channel that interfere with the motor slide path.
9. Slide out the motor and motor mounting plate.
10. Disconnect wiring connections and remove the 4 mounting bolts.
11. Remove the motor.
12. To install the new motor, reverse Steps 1-11.

Belt Tension Adjustment — To adjust belt tension:

1. Loosen fan motor bolts.
2. Adjust belt tension:
 - a. Size 016 Units: Move motor mounting plate up or down for proper belt tension ($1/2$ in. deflection with one finger).
 - b. Size 020-028 Units: Turn motor jacking bolt to move motor mounting plate up or down for proper belt tension ($3/8$ in. deflection at midspan with one finger [9 lb force]).

3. Tighten nuts.
4. Adjust bolts and nut on mounting plate to secure motor in fixed position.

Condenser-Fan Adjustment

50TM016,020,028 UNITS (Fig. 48)

1. Shut off unit power supply.
2. Remove access panel(s) closest to the fan to be adjusted.
3. Loosen fan hub setscrews.
4. Adjust fan height on shaft using a straightedge placed across the fan orifice.
5. Tighten setscrews and replace panel(s).
6. Turn on unit power.

50TM025 UNITS (Fig. 49)

1. Shut off unit power supply.
2. Remove fan top-grille assembly and loosen fan hub screws.
3. Adjust fan height on unit, using a straightedge placed across the fan orifice.
4. Tighten setscrews and replace rubber hubcap to prevent hub from rusting to motor shaft.
5. Fill hub recess with permagum if rubber hubcap is missing.

Power Failure — Dampers have a spring return. In event of power failure, dampers will return to fully closed position until power is restored. *Do not manually operate damper motor.*

Refrigerant Charge — Amount of refrigerant charge is listed on unit nameplate and in Table 1. Refer to Carrier GTAC II; Module 5; Charging, Recovery, Recycling, and Reclamation section for charging methods and procedures. Unit panels must be in place when unit is operating during charging procedure.

NOTE: Do not use recycled refrigerant as it may contain contaminants.

NO CHARGE — Use standard evacuating techniques. After evacuating system, weigh in the specified amount of refrigerant (refer to Table 1).

LOW CHARGE COOLING — Using cooling charging chart (see Fig. 50), add or remove refrigerant until conditions of the chart are met. Note that charging chart is different from those normally used. An accurate pressure gage and temperature-sensing device is required. Charging is accomplished by ensuring the proper amount of liquid subcooling. Measure liquid line pressure at the liquid line service valve using pressure gage. Connect temperature sensing device to the liquid line near the liquid line service valve and insulate it so that outdoor ambient temperature does not affect reading.

TO USE THE COOLING CHARGING CHART — Use the above temperature and pressure readings, and find the intersection point on the cooling charging chart. If intersection point on chart is above line, add refrigerant. If intersection point on chart is below line, carefully recover some of the charge. Re-check suction pressure as charge is adjusted.

NOTE: Indoor-air cfm must be within normal operating range of unit. All outdoor fans must be operating.

The TXV (thermostatic expansion valve) is set to maintain between 15 and 20 degrees of superheat at the compressors. The valves are factory set and should not require re-adjustment.

MOISTUREMISER™ SYSTEM CHARGING — The system charge for units with the MoistureMi\$er option is greater than that of the standard unit alone. The charge for units with this option is indicated on the unit nameplate drawing. To

charge systems using the MoistureMi\$er dehumidification package, fully evacuate, recover, and re-charge the system to the nameplate specified charge level. To check or adjust refrigerant charge on systems using the MoistureMi\$er dehumidification package, charge per the standard subcooling charts. The subcooler **MUST** be deenergized to use the charging charts. The charts reference a liquid pressure (psig) and temperature at a point between the condenser coil and the subcooler coil. A tap is provided on the unit to measure liquid pressure entering the subcooler (leaving the condenser).

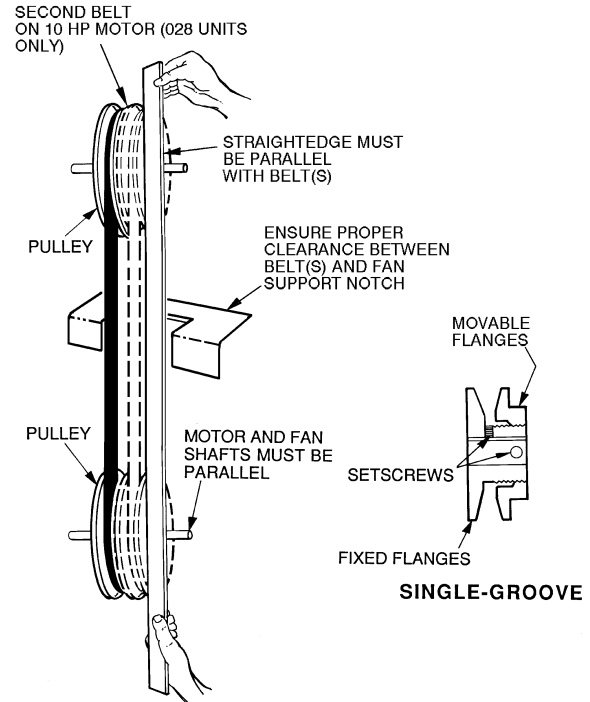
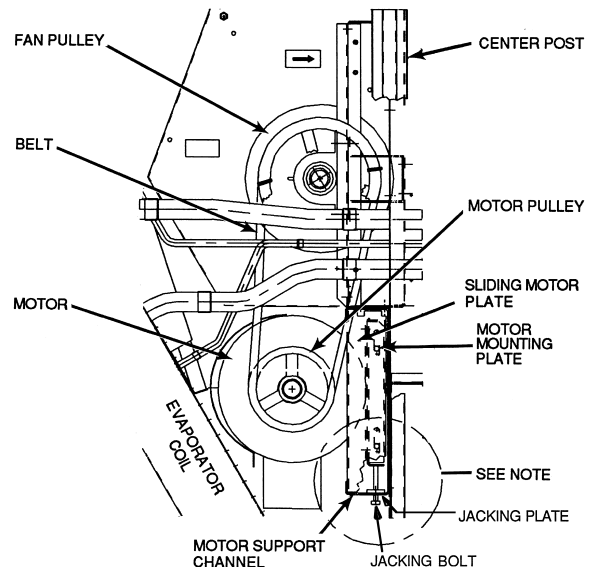
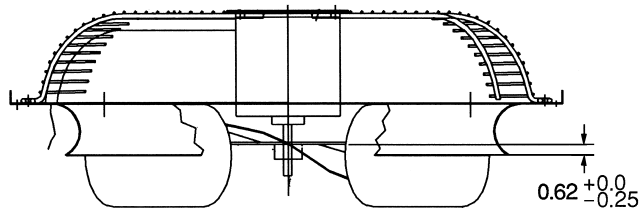

Fig. 46 — Evaporator-Fan Pulley Alignment and Adjustment



NOTE: A 3¹/₂-in. bolt and threaded plate are included in the installer's packet. They should be added to the motor support channel below the motor mounting plate to aid in raising the motor. The plate part number is 50DP503842. The adjustment bolt is 3/8-16 x 1³/₄ in.-LG.

Fig. 47 — Evaporator-Fan Motor Section



NOTE: Dimensions are in inches).

Fig. 48 — Condenser-Fan Adjustment, 50TM016,020,028

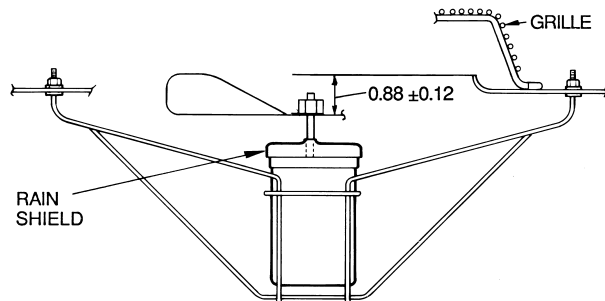

NOTE: Dimensions are in inches.

Fig. 49 — Condenser-Fan Adjustment, 50TM025

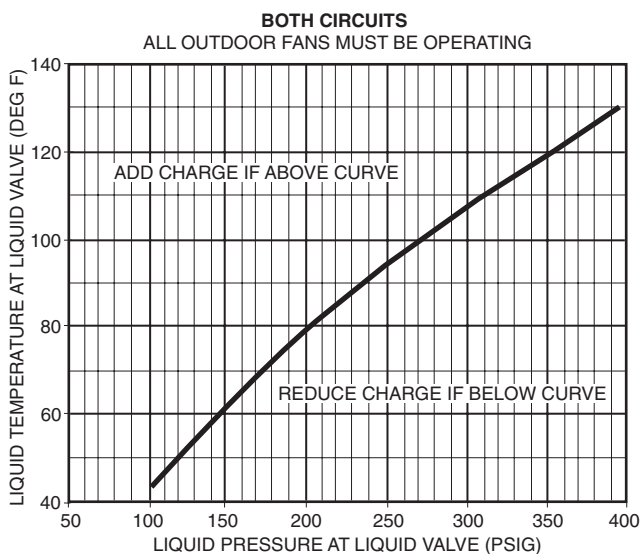

Fig. 50 — Cooling Charging Chart

Filter Drier — Replace whenever refrigerant system is exposed to atmosphere.

Protective Devices

COMPRESSOR PROTECTION

Overcurrent — Each compressor has internal line break motor protection.

Crankcase Heater — All units are equipped with a 70-watt crankcase heater to prevent absorption of liquid refrigerant by oil in the crankcase when the compressor is idle. The crankcase heater is energized whenever there is a main power to the unit and the compressor is not energized.

IMPORTANT: After prolonged shutdown or servicing, energize the crankcase heaters for 24 hours before starting the compressors.

Compressor Lockout — If any of the safeties (high-pressure, low-pressure, freeze protection thermostat, compressor internal thermostat) trip, or if there is loss of power to the compressors, the CLO (compressor lockout) will lock the compressors off. To reset, manually move the thermostat setting.

EVAPORATOR FAN MOTOR PROTECTION — A manual reset, calibrated trip, magnetic circuit breaker protects against overcurrent. Do not bypass connections or increase the size of the breaker to correct trouble. Determine the cause and correct it before resetting the breaker.

CONDENSER-FAN MOTOR PROTECTION — Each condenser-fan motor is internally protected against overtemperature.

HIGH-PRESSURE AND LOW-PRESSURE SWITCHES — If either switch trips, or if the compressor overtemperature switch activates, that refrigerant circuit will be automatically locked out by the CLO. To reset, manually move the thermostat setting.

FREEZE PROTECTION THERMOSTAT (FPT) — An FPT is located on the top and bottom of the evaporator coil. It detects frost build-up and turns off the compressor, allowing the coil to clear. Once the frost has melted, the compressor can be reenergized.

Relief Devices — All units have relief devices to protect against damage from excessive pressures (e.g., fire). These devices protect the high and low side.

Control Circuit, 24-V — This control circuit is protected against overcurrent by a 3.2-amp circuit breaker. Breaker can be reset. If it trips, determine cause of trouble before resetting. See Fig. 51 and 52 for typical wiring.

Replacement Parts — A complete list of replacement parts may be obtained from any Carrier distributor upon request.

Diagnostic LEDs — The unit control boards have LEDs for diagnostic purpose. Refer to Troubleshooting section on page 43.

Optional Hinged Access Doors — When the optional service package is ordered or the if the hinged access doors option is ordered, the unit will be provided with external and internal hinged access doors to facilitate service.

Four external hinged access doors are provided on size 016-025 units. Two external hinged doors are provided on size 028 units. All external doors are provided with 2 large 1/4 turn latches with folding bail-type handles. (Compressor access doors have one latch.) A single door is provided for filter and drive access. One door is provided for control box access. The control box access door is interlocked with the non-fused disconnect which must be in the OFF position to open the door. On size 016-025 units, two doors are provided for access to the compressor compartment.

Two internal access doors are provided inside the filter/drive access door. The filter access door (on the left) is secured by 2 small 1/4 turn latches with folding bail-type handles. This door must be opened prior to opening the drive access door. The drive access door is shipped with 2 sheet metal screws holding the door closed. Upon initial opening of the door, these screws may be removed and discarded. The door is then held shut by the filter access door, which closes over it.

ELECTRIC HEAT		
	208/240V AMPS	200/230V KW
A	71.3/82.3	25.7/34.2
B	117/135	42.2/56.1
C	156/180	56.2/74.8

1
2
3
5
6
7
9
10
13

20
22
26
28

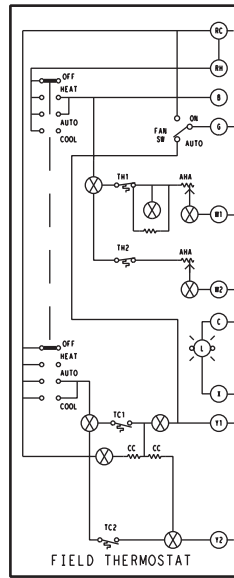

OCCUPIED
UNOCCUPIED
OCCUPANCY SWITCH
(FIELD INSTALLED ACCESSORY)
REMOVE RED JUMPER WHEN INSTALLED

208/230V TM016_020	SHT 1 USED FOR REVISION RECORD	
208/230V 017 TON	PART NUMBER 50HJ503171 SHT 2 OF 3	REV 6.0

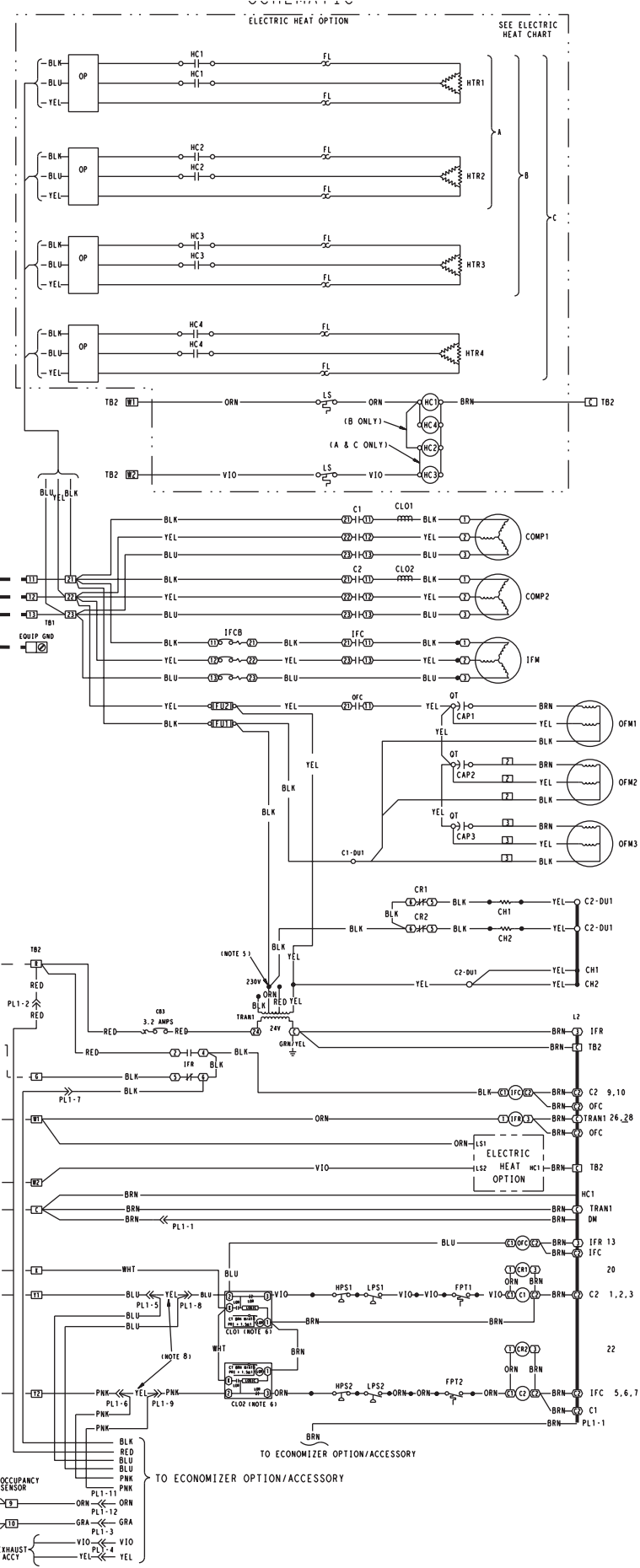

Fig. 51 — Typical Wiring Schematic (50TM016,020 208/230 V Shown)

COMPONENT ARRANGEMENT

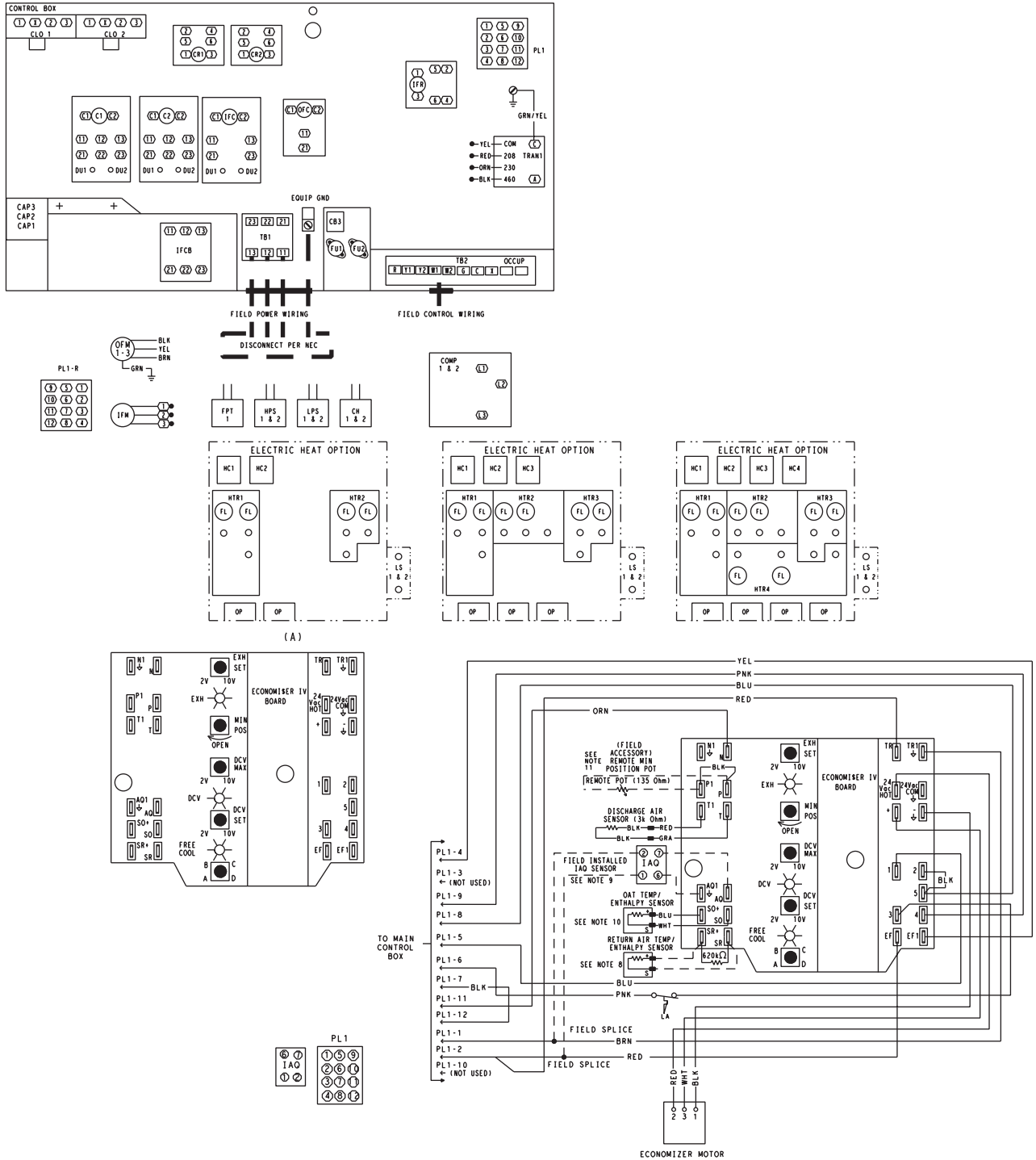















Fig. 52 — Typical Component Arrangement (50TM016,020 Shown)

LEGEND AND NOTES FOR FIG 51 AND 52

LEGEND

AHA	— Adjustable, Heat Anticipator	PL	— Plug Assembly
C	— Contactor, Compressor	PRI	— Primary
CAP	— Capacitor	QT	— Quadruple Terminal
CB	— Circuit Breaker	RAT	— Return Air Temperature Sensor
CC	— Cooling Compensator	SW	— Switch
CH	— Crankcase Heater	TB	— Terminal Block
CLO	— Compressor Lockout	TC	— Thermostat Cooling
COMP	— Compressor Motor	TH	— Thermostat Heating
CR	— Control Relay	TRAN	— Transformer
DM	— Damper Motor		Terminal (Marked)
DU	— Dummy Terminal		Terminal (Unmarked)
EQUIP	— Equipment		Terminal Block
FL	— Filament		Splice
FPT	— Freeze Protection Thermostat		Factory Wiring
FU	— Fuse		Field Wiring
GND	— Ground		Option/Accessory Wiring
HC	— Heater Contactor		To indicate common potential only; not to represent wiring.
HPS	— High-Pressure Switch		Economizer Motor
HTR	— Heater		Remote Pot Field Accessory
IAQ	— Indoor Air Quality Sensor		OAT Sensor
IFC	— Indoor Fan Contactor		Disch Air Sensor
IFCB	— Indoor Fan Circuit Breaker		RAT Accessory Sensor
IFM	— Indoor Fan Motor		Low Ambient Lockout Switch
IFR	— Indoor Fan Relay		
L	— Light		
LOR	— Lockout Relay		
LPS	— Low-Pressure Switch		
LS	— Limit Switch		
NEC	— National Electrical Code		
OAT	— Outdoor Air Temperature Sensor		
OCCUP	— Occupancy Sensor		
OFC	— Outdoor Fan Contactor		
OFM	— Outdoor Fan Motor		
OP	— Overcurrent Protection		

NOTES:

1. Compressor and/or fan motor(s) thermally protected three phase motors protected against primary single phasing conditions.
2. If any of the original wire furnished must be replaced, it must be replaced with Type 90° C or its equivalent.
3. Jumpers are omitted when unit is equipped with economizer.
4. IFCB must trip amps is equal to or less than 140% FLA.
5. On TRAN1 use BLK lead for 460 v power supply and ORN lead for 575 v power supply.
6. The CLO locks out the compressor to prevent short cycling on compressor overload and safety devices. Before replacing CLO, check these devices.
7. Number(s) indicates the line location of used contacts. A bracket over (2) numbers signifies a single pole, double throw contact. An underlined number signifies a normally closed contact. Plain (no line) number signifies a normally open contact.
8. 620 Ohm, 1 watt, 5% resistor should be removed only when using differential enthalpy or dry bulb.
9. If a separate field supplied 24 v transformer is used for the IAQ sensor power supply, it cannot have the secondary of the transformer grounded.
10. OAT sensor is shipped inside unit and must be relocated in the field for proper operation.
11. For field installed remote minimum position POT. remove black wire jumper between P and P1 and set control minimum position POT to the minimum position.

TROUBLESHOOTING

Unit Troubleshooting — Refer to Tables 21 and 22 for troubleshooting details.

EconoMi\$erIV Troubleshooting — See Table 23 for EconoMi\$erIV logic.

A functional view of the EconoMi\$er is shown in Fig. 53. Typical settings, sensor ranges, and jumper positions are also shown. An EconoMi\$erIV simulator program is available from Carrier to help with EconoMi\$erIV training and troubleshooting.

ECONOMI\$ERIV PREPARATION — This procedure is used to prepare the EconoMi\$erIV for troubleshooting. No troubleshooting or testing is done by performing the following procedure.

NOTE: This procedure requires a 9-v battery, 1.2 kilo-ohm resistor, and a 5.6 kilo-ohm resistor which are not supplied with the EconoMi\$erIV.

IMPORTANT: Be sure to record the positions of all potentiometers before starting troubleshooting.

1. Disconnect power at TR and TR1. All LEDs should be off. Exhaust fan contacts should be open.
2. Disconnect device at P and P1.
3. Jumper P to P1.
4. Disconnect wires at T and T1. Place 5.6 kilo-ohm resistor across T and T1.
5. Jumper TR to 1.
6. Jumper TR to N.
7. If connected, remove sensor from terminals S_O and +. Connect 1.2 kilo-ohm 4074EJM checkout resistor across terminals S_O and +.
8. Put 620-ohm resistor across terminals S_R and +.
9. Set minimum position, DCV set point, and exhaust potentiometers fully CCW (counterclockwise).
10. Set DCV maximum position potentiometer fully CW (clockwise).
11. Set enthalpy potentiometer to D.
12. Apply power (24 vac) to terminals TR and TR1.

DIFFERENTIAL ENTHALPY — To check differential enthalpy:

1. Make sure EconoMi\$erIV preparation procedure has been performed.
2. Place 620-ohm resistor across S_O and +.
3. Place 1.2 kilo-ohm resistor across S_R and +. The Free Cool LED should be lit.
4. Remove 620-ohm resistor across S_O and +. The Free Cool LED should turn off.
5. Return EconoMi\$erIV settings and wiring to normal after completing troubleshooting.

SINGLE ENTHALPY — To check single enthalpy:

1. Make sure EconoMi\$erIV preparation procedure has been performed.
2. Set the enthalpy potentiometer to A (fully CCW). The Free Cool LED should be lit.
3. Set the enthalpy potentiometer to D (fully CW). The Free Cool LED should turn off.
4. Return EconoMi\$erIV settings and wiring to normal after completing troubleshooting.

DCV (Demand Controlled Ventilation) AND POWER EXHAUST — To check DCV and Power Exhaust:

1. Make sure EconoMi\$erIV preparation procedure has been performed.
2. Ensure terminals AQ and AQ1 are open. The LED for both DCV and Exhaust should be off. The actuator should be fully closed.
3. Connect a 9-v battery to AQ (positive node) and AQ1 (negative node). The LED for both DCV and Exhaust

should turn on. The actuator should drive to between 90 and 95% open.

4. Turn the Exhaust potentiometer CW until the Exhaust LED turns off. The LED should turn off when the potentiometer is approximately 90%. The actuator should remain in position.
5. Turn the DCV set point potentiometer CW until the DCV LED turns off. The DCV LED should turn off when the potentiometer is approximately 9-v. The actuator should drive fully closed.
6. Turn the DCV and Exhaust potentiometers CCW until the Exhaust LED turns on. The exhaust contacts will close 30 to 120 seconds after the Exhaust LED turns on.
7. Return EconoMi\$erIV settings and wiring to normal after completing troubleshooting.

DCV MINIMUM AND MAXIMUM POSITION — To check the DCV minimum and maximum position:

1. Make sure EconoMi\$erIV preparation procedure has been performed.
2. Connect a 9-v battery to AQ (positive node) and AQ1 (negative node). The DCV LED should turn on. The actuator should drive to between 90 and 95% open.
3. Turn the DCV Maximum Position potentiometer to mid-point. The actuator should drive to between 20 and 80% open.
4. Turn the DCV Maximum Position potentiometer to fully CCW. The actuator should drive fully closed.
5. Turn the Minimum Position potentiometer to midpoint. The actuator should drive to between 20 and 80% open.
6. Turn the Minimum Position Potentiometer fully CW. The actuator should drive fully open.
7. Remove the jumper from TR and N. The actuator should drive fully closed.
8. Return EconoMi\$erIV settings and wiring to normal after completing troubleshooting.

SUPPLY-AIR INPUT — To check supply-air input:

1. Make sure EconoMi\$erIV preparation procedure has been performed.
2. Set the Enthalpy potentiometer to A. The Free Cool LED turns on. The actuator should drive to between 20 and 80% open.
3. Remove the 5.6 kilo-ohm resistor and jumper T to T1. The actuator should drive fully open.
4. Remove the jumper across T and T1. The actuator should drive fully closed.
5. Return EconoMi\$erIV settings and wiring to normal after completing troubleshooting.

ECONOMI\$ERIV TROUBLESHOOTING COMPLETION — This procedure is used to return the EconoMi\$erIV to operation. No troubleshooting or testing is done by performing the following procedure.

1. Disconnect power at TR and TR1.
2. Set enthalpy potentiometer to previous setting.
3. Set DCV maximum position potentiometer to previous setting.
4. Set minimum position, DCV set point, and exhaust potentiometers to previous settings.
5. Remove 620-ohm resistor from terminals S_R and +.
6. Remove 1.2 kilo-ohm checkout resistor from terminals S_O and +. If used, reconnect sensor from terminals S_O and +.
7. Remove jumper from TR to N.
8. Remove jumper from TR to 1.
9. Remove 5.6 kilo-ohm resistor from T and T1. Reconnect wires at T and T1.
10. Remove jumper from P to P1. Reconnect device at P and P1.
11. Apply power (24 vac) to terminals TR and TR1.

Table 21 — MoistureMi\$er™ Dehumidification Subcooler Service Analysis

PROBLEM	CAUSE	REMEDY
Subcooler Will Not Energize	No power to subcooler control transformer.	Check power source. Ensure all wire connections are tight.
	No power from subcooler control transformer to liquid line three-way valve.	1. Fuse open; check fuse. Ensure continuity of wiring. 2. Subcooler control low pressure switch open. Cycle unit off and allow low-pressure switch to reset. Replace switch if it will not close. 3. Transformer bad; check transformer.
	Liquid line three-way valve will not operate.	1. Solenoid coil defective; replace. 2. Solenoid valve stuck closed; replace.
Subcooler Will Not Deenergize	Liquid Line three-way valve will not close.	Valve is stuck open; replace.
Low System Capacity	Low refrigerant charge or frosted coil.	1. Check charge amount. See system charging section. 2. Evaporator coil frosted; check and replace subcooler control low-pressure switch if necessary.

Table 22 — Cooling Service Analysis

PROBLEM	CAUSE	REMEDY
Compressor and Condenser Fan Will Not Start.	Power failure.	Call power company.
	Fuse blown or circuit breaker tripped.	Replace fuse or reset circuit breaker.
	Defective thermostat, contactor, transformer, or control relay.	Replace component.
	Insufficient line voltage.	Determine cause and correct.
	Incorrect or faulty wiring.	Check wiring diagram and rewire correctly.
Compressor Will Not Start but Condenser Fan Runs.	Thermostat setting too high.	Lower thermostat setting below room temperature.
	Faulty wiring or loose connections in compressor circuit.	Check wiring and repair or replace.
	Compressor motor burned out, seized, or internal overload open.	Determine cause. Replace compressor.
	Defective overload.	Determine cause and replace.
	Compressor locked out	Determine cause for safety trip and reset lockout.
Compressor Cycles (other than normally satisfying thermostat).	One leg of 3-phase power dead.	Replace fuse or reset circuit breaker. Determine cause.
	Refrigerant overcharge or undercharge.	Recover refrigerant, evacuate system, and recharge to nameplate.
	Defective compressor.	Replace and determine cause.
	Insufficient line voltage.	Determine cause and correct.
	Blocked condenser.	Determine cause and correct.
	Defective overload.	Determine cause and replace.
	Defective thermostat.	Replace thermostat.
Compressor Operates continuously.	Faulty condenser-fan motor.	Replace.
	Restriction in refrigerant system.	Locate restriction and remove.
	Dirty air filter.	Replace filter.
	Unit undersized for load.	Decrease load or increase unit size.
	Thermostat set too low.	Reset thermostat.
	Low refrigerant charge.	Locate leak, repair, and recharge.
Excessive Head Pressure.	Air in system.	Recover refrigerant, evacuate system, and recharge.
	Condenser coil dirty or restricted.	Clean coil or remove restriction.
	Dirty air filter.	Replace filter.
	Dirty condenser coil.	Clean coil.
	Refrigerant overcharged.	Recover excess refrigerant.
	Faulty TXV.	1. Check TXV bulb mounting and secure tightly to suction line. 2. Replace TXV if stuck open or closed.
Head Pressure Too Low.	Air in system.	Recover refrigerant, evacuate system, and recharge.
	Condenser air restricted or air short-cycling.	Determine cause and correct.
	Low refrigerant charge.	Check for leaks, repair, and recharge.
Excessive Suction Pressure.	Restriction in liquid tube.	Remove restriction.
	High heat load.	Check for source and eliminate.
	Faulty TXV.	1. Check TXV bulb mounting and secure tightly to suction line. 2. Replace TXV if stuck open or closed.
Suction Pressure Too Low.	Refrigerant overcharged.	Recover excess refrigerant.
	Dirty air filter.	Replace filter.
	Low refrigerant charge.	Check for leaks, repair, and recharge.
	Metering device or low side restricted.	Remove source of restriction.
	Faulty TXV.	1. Check TXV bulb mounting and secure tightly to suction line. 2. Replace TXV if stuck open or closed.
	Insufficient evaporator airflow.	Increase air quantity. Check filter and replace if necessary.
Field-installed filter drier restricted.	Temperature too low in conditioned area.	Reset thermostat.
	Field-installed filter drier restricted.	Replace.

LEGEND

TXV — Thermostatic Expansion Valve

Table 23 — EconoMi\$erIV Input/Output Logic

Demand Control Ventilation (DCV)	INPUTS				OUTPUTS			
	Enthalpy*		Y1	Y2	Compressor		N Terminal†	
	Outdoor	Return			Stage 1	Stage 2	Occupied	Unoccupied
Below set (DCV LED Off)	High (Free Cooling LED Off)	Low	On	On	On	On	Minimum position	Closed
			On	Off	On	Off		
			Off	Off	Off	Off		
	Low (Free Cooling LED On)	High	On	On	On	Off	Modulating** (between min. position and full-open)	Modulating** (between closed and full-open)
			On	Off	Off	Off		
			Off	Off	Off	Off		
Above set (DCV LED On)	High (Free Cooling LED Off)	Low	On	On	On	On	Modulating†† (between min. position and DCV maximum)	Modulating†† (between closed and DCV maximum)
			On	Off	On	Off		
			Off	Off	Off	Off		
	Low (Free Cooling LED On)	High	On	On	On	Off	Modulating***	Modulating†††
			On	Off	Off	Off		
			Off	Off	Off	Off		

*For single enthalpy control, the module compares outdoor enthalpy to the ABCD set point.

†Power at N terminal determines Occupied/Unoccupied setting: 24 Vac (Occupied), no power (Unoccupied).

**Modulation is based on the supply air sensor signal.

††Modulation is based on the DCV signal.

***Modulation is based on the greater of DCV and supply air sensor signals, between minimum position and either maximum position (DCV) or fully open (supply air signal).

†††Modulation is based on the greater of DCV and supply air sensor signals, between closed and either maximum position (DCV) or fully open (supply air signal).

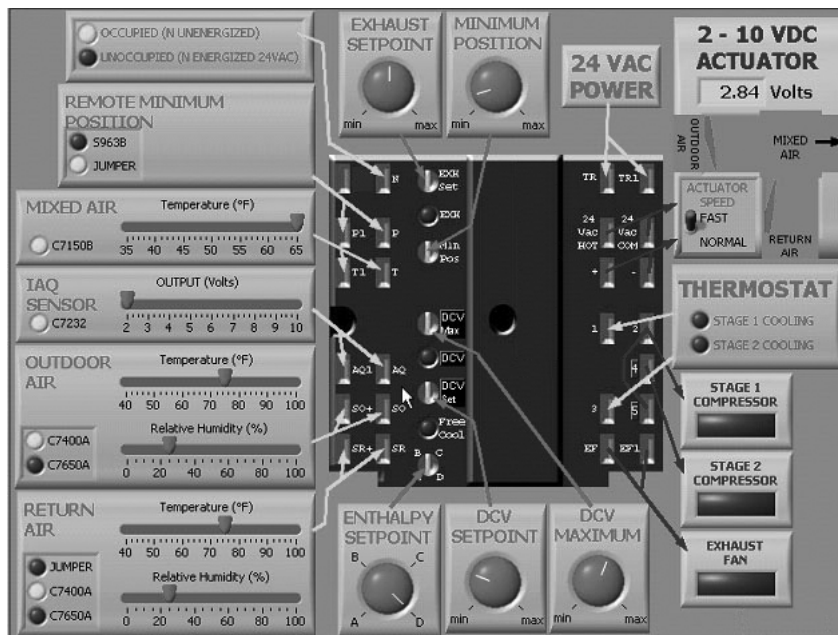

Fig. 53 — EconoMi\$erIV Functional View

INDEX

- Air quantity limits 30
- Carrier Comfort Network® 16
- Charging chart, refrigerant 39
- Clearance 4-7
- CO₂ sensor
 - Configuration 27
 - Settings 26, 27
- Compressor
 - Lubrication 37
 - Mounting 30
 - Rotation 30
- Condensate drain
 - Cleaning 37
 - Location 9, 10
- Condenser coil 8
 - Cleaning 37
- Condenser fan 8
 - Adjustment 38, 39
- Control circuit
 - Wiring 10
- Convenience outlet 13
- Demand control ventilation 26
 - Dehumidification 27
- Dimensions 2, 3, 5-7
- Ductwork 9
- EconoMiSer^{IV} 22-27
 - Control mode 24
 - Controller wiring 23
 - Damper movement 26
 - Demand ventilation control 26
 - Troubleshooting 43, 45
 - Usage 24
 - Wiring 23
- EconoMiSer² 22, 23
- Electrical connections 10
- Electrical data 11, 12
- Enthalpy changeover set points 25
- Evaporator coil 8
 - Cleaning 37
- Evaporator fan motor
 - Lubrication 37
 - Motor data 34
 - Performance 31-33
 - Pulley adjustment 37, 38
 - Pulley setting 8, 34
 - Speed 34
- Filter
 - Cleaning 37
 - Size 8
- Freeze protection thermostat 8, 39
- Heat anticipator settings 13
- High-pressure switch 8, 39
- Horizontal adapter roof curb 4
- Humidistat 28
- Indoor air quality sensor 16
- Low-pressure switch 8, 39
- Manual outdoor air damper 13
- MoistureMiSerTM
 - dehumidification 28, 29, 38, 44
- Motormaster® control 14, 15
- Mounting
 - Compressor 30
 - Unit 4
- Non-fused disconnect 13
- Operating limits 15
- Operating sequence 35, 36
 - Cooling 35
 - EconoMiSer^{IV} 35
 - EconoMiSer² with
 - PremierLink control 35, 36
 - Heating 35
- Outdoor air hood 13, 14
- Outdoor air temperature sensor 16, 22
- Outdoor air inlet screens
 - Cleaning 37
 - Dimensions 8
 - Physical data 8
 - Power supply 10
 - Wiring 10
- PremierLinkTM controls 16-19
- Pressure, drop
 - Economizer 33
 - Electric heat 33
 - MoistureMiSer 33
- Pressure switches
 - High pressure 8
 - Low pressure 8
- Refrigerant
 - Charge 38
 - Type 8
- Refrigerant service ports 30
- Replacement parts 39
- Return air filter 8, 30
- Return air temperature sensor 25
- Rigging unit 4
- Roof curb
 - Assembly 1
 - Dimensions 2, 3
 - Leveling tolerances 2-4
- Safety considerations 1
- Service 37-42
- Start-up 30-36
- Start-up checklist *CL-1*
- Supply-air temperature sensor 16, 22
- Thermostat 10
- Troubleshooting 43-45
- Weight
 - Corner 5-7
 - Economizer 5-8
 - Maximum 4
 - Unit 5-8
- Wind baffle 14, 15
- Wiring
 - Differential enthalpy control 21
 - EconoMiSer^{IV} 23
 - EconoMiSer² 23
 - Power connections 10
 - PremierLink 18
 - Thermostat 10
 - Unit 40, 41

START-UP CHECKLIST

MODEL NO.: _____ SERIAL NO.: _____

DATE: _____ TECHNICIAN: _____

PRE-START-UP:

- VERIFY THAT ALL PACKING MATERIALS HAVE BEEN REMOVED FROM UNIT
- VERIFY INSTALLATION OF INDOOR FAN MOTOR ADJUSTMENT BOLT AND PLATE
- VERIFY INSTALLATION OF ECONOMIZER HOOD
- VERIFY THAT CONDENSATE CONNECTION IS INSTALLED PER INSTRUCTIONS
- VERIFY THAT ALL ELECTRICAL CONNECTIONS AND TERMINALS ARE TIGHT
- CHECK THAT FILTERS AND SCREENS ARE CLEAN AND IN PLACE
- VERIFY THAT UNIT IS LEVEL
- CHECK FAN WHEEL AND PROPELLER FOR LOCATION IN HOUSING/ORIFICE, AND VERIFY SETSCREW IS TIGHT
- VERIFY THAT FAN SHEAVES ARE ALIGNED AND BELTS ARE PROPERLY TENSIONED
- VERIFY THAT SCROLL COMPRESSOR IS ROTATING IN THE CORRECT DIRECTION
- VERIFY THAT CRANKCASE HEATER HAS BEEN ENERGIZED FOR 24 HOURS

START-UP:

ELECTRICAL

SUPPLY VOLTAGE L1-L2 _____ L2-L3 _____ L3-L1 _____

COMPRESSOR AMPS — COMPRESSOR NO. 1 L1 _____ L2 _____ L3 _____

— COMPRESSOR NO. 2 L1 _____ L2 _____ L3 _____

SUPPLY FAN AMPS _____ EXHAUST FAN AMPS _____

ELECTRIC HEAT AMPS (IF SO EQUIPPED) L1 _____ L2 _____ L3 _____

TEMPERATURES

OUTDOOR-AIR TEMPERATURE _____ F DB (Dry-Bulb)

RETURN-AIR TEMPERATURE _____ F DB _____ F WB (Wet-Bulb)

COOLING SUPPLY AIR _____ F

ELECTRIC HEAT SUPPLY AIR (IF SO EQUIPPED) _____ F

PRESSURES

REFRIGERANT SUCTION CIRCUIT NO. 1 _____ PSIG CIRCUIT NO. 2 _____ PSIG

REFRIGERANT DISCHARGE CIRCUIT NO. 1 _____ PSIG CIRCUIT NO. 2 _____ PSIG

- VERIFY REFRIGERANT CHARGE USING CHARGING CHART ON PAGE 39.

GENERAL

- ECONOMIZER MINIMUM VENT AND CHANGEOVER SETTINGS TO JOB REQUIREMENTS
- VERIFY INSTALLATION OF ALL OPTIONS AND ACCESSORIES

CUT ALONG DOTTED LINE

CUT ALONG DOTTED LINE