

FEATURES & SPECIFICATIONS

INTENDED USE — Provides a minimum of 90 minutes of illumination for the rated wattage upon loss of AC power. Ideal for applications requiring attractive unit equipment with quick installation.

CONSTRUCTION — White, compact, low-profile contemporary design. Engineering-grade thermoplastic housing is impact-resistant, scratch-resistant and corrosion-proof. UL94V-0 flame rating. UV-stable resin resists discoloration from natural and man-made light sources.

Two 5.4W wedge-based krypton lamps offer 32 percent more light output than standard incandescent lamps.

Patented MR24, multi-faceted reflector significantly improves photometric performance – 60 to 100 percent more light delivered to path of egress. **US Patent No. D484,272**

Dual-voltage input capability (120/277V). Edge connectors on printed circuit board ensure long-term durability.

Low-profile, integrated test switch/pilot light. Easily visible bright red status indicator.

Unique track-and-swivel arrangement permits full range of direction of lamp head adjustment. Universal J-box mounting pattern. Tool-less access for maintenance. Flexible conduit entry provision on top of the unit. Ceiling mount standard. **U.S. Patent No. D473,672**

BATTERY: Sealed, maintenance-free lead-calcium battery provides 12W rated capacity. Automatic 48-hour recharge after a 90-minute discharge.

Low-voltage disconnect prevents excessively deep discharge that can permanently damage the battery.

Single-circuit battery connection. Galvanized battery retaining clip.

ELECTRICAL — Current-limiting charger maximizes battery life and minimizes energy consumption. Provides low operating costs.

Short-circuit protection — current-limiting charger circuitry protects printed circuit board from shorts.

Thermal protection senses circuitry temperature and adjusts charge current to prevent overheating and charger failure.

Thermal compensation adjusts charger output to provide optimum charge voltage relative to ambient temperature.

Regulated charge voltage maintains constant-charge voltage over a wide range of line voltages. Prevents over/undercharging that shortens battery life and reduces capacity.

Filtered charger input minimizes charge voltage ripple and extends battery life.

AC/LVD reset allows battery connection before AC power is applied and prevents battery damage from deep discharge.

Brownout protection is automatically switched to emergency mode when supply voltage drops below 80 percent of nominal.

DIAGNOSTICS (SD option): Single multi-chromatic LED indicator to display two-state charging, test activation and three-state diagnostic status.

Test switch provides manual activation of 30-second diagnostic testing for on-demand visual inspection.

Self-diagnostic testing for five minutes every 30 days and 30 minutes every six months.

Diagnostic evaluation of lamp, AC to DC transfer, charging and battery condition.

Brownout protection is a standard feature of self-diagnostics.

Continuously monitors AC functionality.

Automatic test is easily postponed for eight hours by activating manual test switch.

Catalog Number
Notes
Type

Thermoplastic Emergency Light

ELM2

LEAD-CALCIUM BATTERY



Specifications

Length: 12-1/2 (31.8)

Depth: 3-3/4 (9.5)

Height: 5 (12.7)

Weight: 4.0 lbs (1.8 kg)

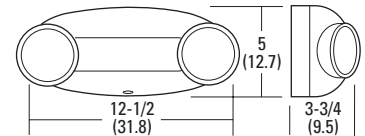

All dimensions are inches (centimeters) unless otherwise specified.

LISTINGS — UL Listed and NOM Certified (standard). Meets UL 924, NFPA 101 (current Life Safety Code), NFPA 70-NEC and OSHA illumination standards. Meets Mexican standards.

WARRANTY — Three-year warranty.

Note: Specifications subject to change without notice.

ORDERING INFORMATION

For shortest lead times, configure product using **standard options (shown in bold)**.

Example: ELM2

ELM2		
Family	Options	
ELM2	B	Black housing ¹
	DL	Damp location listed (10°C to 40°C) ¹
	SD	Self-diagnostics

Accessories ² : Order as separate item.	
ELA VS	Thermoplastic vandal shield ²
ELA WG1	Wireguard, 15"W x 13-1/2"H x 6"D ³

Notes

- 1 Black unit not available with damp location option.
- 2 See spec sheet [ELA-RTL-MS-VS2](#).
- 3 See spec sheet [ELA-WG](#).

ELM2 Quantum® Thermoplastic Emergency Light

SPECIFICATIONS

ELECTRICAL							
Primary Circuit							
Type	Volts	Input Amps	Watts	Output volts	Watts output ¹		
					1-1/2 hrs.	2hrs.	
ELM2	120	.11	1.2	6	12	9	
	277	.12	1.5				

BATTERY				
Sealed Lead Calcium				
Voltage	Shelf life ²	Expected life ²	Maintenance ³	Optimum temperature ⁴
6	12 months	5 - 7 years	none	60° - 90°F (16° - 32°C)

- 1 Half-hour and one-hour run time not applicable for U.S. product.
- 2 At 77°F (25°C).
- 3 All life safety equipment, including emergency lighting for path of egress, must be maintained, serviced and tested in accordance with all National Fire Protection Association (NFPA) and local codes. Failure to perform the required maintenance, service or testing could jeopardize the safety of occupants and will void all warranties.
- 4 Optimum ambient temperature range where unit will provide capacity for 30 to 90 minutes. Higher and lower temperatures affect life and capacity. Consult factory for detailed information.

LAMP PHOTOMETRICS

LTL10586
MR24 K0606
6-volts, 5.4-watts krypton

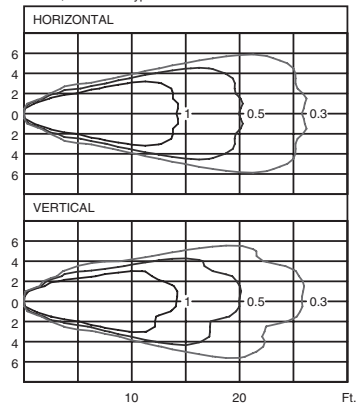

SPACING/COVERAGE GUIDE

MR24 K0606 Lamp	Path of Egress	
	3'-wide	6'-wide
Center-to-Center Spacing	25'	20'
Single-Unit Coverage	24'	18'

MOUNTING

All dimensions are inches (centimeters).
Shipping weight: 7.36 lbs. (3.3 kgs.).

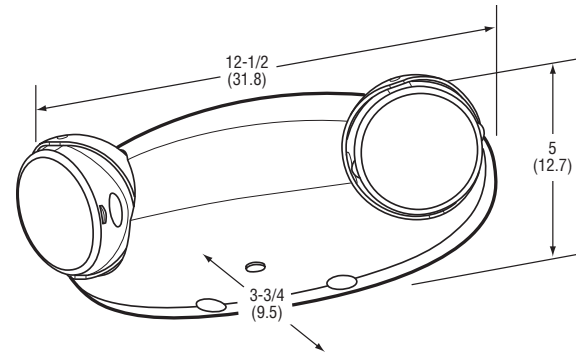

Mounting Plate

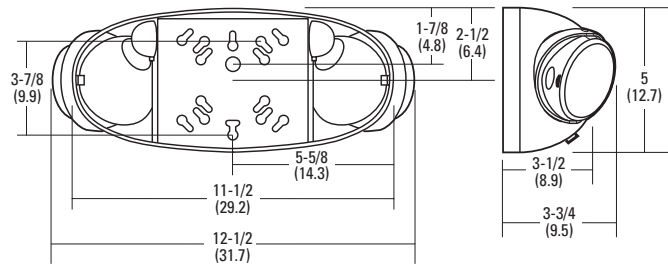

FIXTURE PERFORMANCE

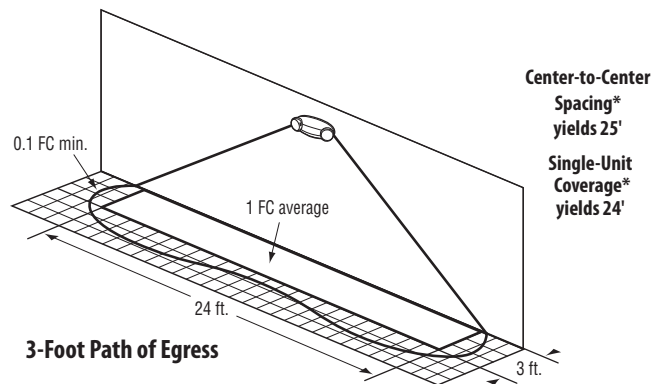
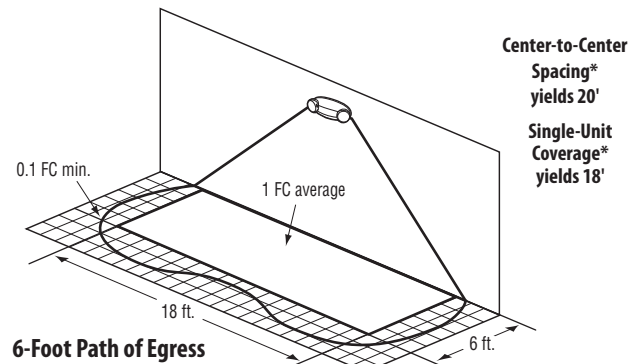

* Meets Life Safety Code standard minimum illuminance of 0.1 FC and average illuminance of 1.0 FC. Assumes open space with no obstructions, mounting height: 7.5'; ceiling height: 9'; and reflectances: 80/50/20. Analysis based on independently tested photometrics.