



Preliminary Split System Submittal

Prepared For:
Brandon Nowakowski
Dammon Engineering Inc.

Date: April 10, 2012

Job Name:
Textron Marine Renovation

Trane U.S. Inc. dba Trane is pleased to provide the enclosed submittal for your review and approval.

Product Summary

Qty	Product
5	Split System Air Conditioning Units (Large)
5	Split System Air Conditioning Units (Small)
5	Packaged Air Handling Units

The attached information describes the equipment we propose to furnish for this project, and is submitted for your approval.

Tyler Schmitz
Trane
530 Elmwood Park Blvd.
New Orleans, LA 70123-3308
Phone: (504) 733-6789
Cell: (504) 240-9759
Fax: (504) 731-0833

Table Of Contents

Product Summary	1
Split System Air Conditioning Units (Large) (Items A1 - A3)	
Tag Data.....	3
Product Data	3
Performance Data	3
Mechanical Specifications	5
Unit Dimensions	6
Weight, Clearance & Rigging Diagram	12
Split System Air Conditioning Units (Small) (Items B1 - B4)	
Tag Data.....	15
Product Data	15
Performance Data	16
Mechanical Specifications	17
Unit Dimensions	19
Weight, Clearance & Rigging Diagram	35
Packaged Air Handling Units (Items C1 - C3)	
Tag Data.....	36
Product Data	36
Performance Data	36
Mechanical Specifications	38
Unit Dimensions	40
Fan Curve.....	49
Weight, Clearance & Rigging Diagram	52
Accessory	55
Field Wiring	58
Field Installed Options - Part/Order Number Summary	
Split System Air Conditioning Units (Large).....	62
Split System Air Conditioning Units (Small).....	62

Tag Data - Split System Air Conditioning Units (Large) (Qty: 5)

Item	Tag(s)	Qty	Description	Model Number
A1	Zone 5 CU, Zone 10 CU	2	6 - 20 Ton Unitary Split Systems	TTA150E400-----000
A2	Zone 2 CU, Zone 3 CU	2	6 - 20 Ton Unitary Split Systems (SSC2	TTA180E400-----000
A3	Zone 8 CU	1	6 - 20 Ton Unitary Split Systems (SSC2	TTA240E400-----000

Product Data - Split System Air Conditioning Units (Large)

Item: A1 Qty: 2 Tag(s): Zone 5 CU, Zone 10 CU

TTA Air Condensing Outdoor Unit
 12 1/2 Ton Nominal Cooling Capacity R410
 Dual Compressors - R410A
 460 Volt 3 Phase 60 Hertz
 Electromechanical Controls (Std/2 Speed)
 Standard motor
 Lontalk communication interface (Fld)
 1 Hot Gas Bypass - Mech. valve R-410A (Fld)

Item: A2 Qty: 2 Tag(s): Zone 2 CU, Zone 3 CU

TTA Air Condensing Outdoor Unit
 15 Ton Nominal Cooling Capacity R410
 Dual Compressors - R410A
 460 Volt 3 Phase 60 Hertz
 Electromechanical Controls (Std/2 Speed)
 Standard motor
 Lontalk communication interface (Fld)
 1 Hot Gas Bypass - Mech. valve R-410A (Fld)

Item: A3 Qty: 1 Tag(s): Zone 8 CU

TTA Air Condensing Outdoor Unit
 20 Ton Nominal Cooling Capacity R410A
 Dual Compressors - R410A
 460 Volt 3 Phase 60 Hertz
 Electromechanical Controls (Std/2 Speed)
 Standard motor
 Lontalk communication interface (Fld)
 1 Hot Gas Bypass - Mech. valve R-410A (Fld)

Performance Data - Split System Air Conditioning Units (Large)

Tags	Zone 5 CU, Zone 10 CU	Zone 2 CU, Zone 3 CU, Zone 8 CU
MCA - cooling only unit (A)	26.40	32.50
MOP - cooling only unit (A)	30.00	40.00
Min. Cond. operating weight (lb)	468.0	723.0
Max. Cond. operating weight (lb)	543.0	850.0
Condensing unit type	Cooling only unit	Cooling only unit
Airflow (cfm)	5000	6000
Cooling EDB (F)	80.00	80.00
Cooling EWB (F)	67.00	67.00
Ambient (F)	95.00	95.00
Relative humidity (%)	51.08	51.08
Gross total capacity (MBh)	154.26	185.52
Gross sensible capacity (MBh)	119.54	135.47
Latent capacity (MBh)	34.73	50.06
Net total capacity (MBh)	149.63	178.71
Net sensible capacity (MBh)	114.90	128.66
Cooling LDB (F)	59.34	60.55
Cooling LWB (F)	57.62	57.59
Saturated suction temp (F)	50.93	45.57

Tags	Zone 5 CU, Zone 10 CU	Zone 2 CU, Zone 3 CU, Zone 8 CU
Discharge temperature (F)	123.81	112.14
Electric Heat Capacity (MBh)	0.00	0.00
Electric heat delta T (F)	0.00	0.00
Line length - actual (ft)	25.00	25.00
Cond. location to A.H.	Same as air handler	Same as air handler
Suction line size od (per circuit)	1-1/8 in.	1-3/8 in.
Liquid line size od (per circuit)	1/2 in	1/2 in
Est. refriger. chrg / circuit (lb)	15.3	19.5
Sight glass part #	GLS00853	GLS00853
Metering device	Expansion valve	Expansion valve
External Static Pressure (in H2O)	0.500	0.500
External plus component static pressure (in H2O)	0.500	0.500
Supply fan power (bhp)	1.47	2.16
Indoor motor RPM (rpm)	721	739
Field applied voltage	460/3/60	460/3/60
MCA - A.H. (A)	3.40	5.80
MOP - A.H. (A)	15.00	15.00
MCA - A.H. for 230V w/elect heat (A)	0.00	0.00
MOP - A.H. for 230V w/elect heat (A)	0.00	0.00
Evaporator motor FLA (A)	2.75	4.60
Evaporator face area (sq ft)	16.33	16.33
Evaporator face velocity (ft/min)	306	367
Evaporator fin spacing (Each)	168.00	168.00
Evaporator rows (Each)	4.00	4.00
Indoor motor power (kW)	1.34	1.97
Condenser Fan Power (kW)	1.01	0.98
Compressor power (kW)	11.49	13.62
Total power (kW)	13.84	16.56
EER @ AHRI (with air handler) (EER)	11.0	11.0
EER @ AHRI (cond. unit only) (EER)	11.0	11.0
IPLV @ AHRI (with Air Handler) (IPLV)	0.0	0.0
IPLV @ AHRI (cond. unit only) (IPLV)	0.0	0.0
Compressor 1 RLA (A)	10.60	12.20
Compressor 2 RLA (A)	10.60	12.20
Condenser motor 1 FLA (A)	2.50	2.50
Condenser motor 2 FLA (A)	0.00	2.50
Min. A.H. operating weight (lb)	676.0	675.0
Max. A.H. operating weight (lb)	730.0	729.0
Fan motor heat (MBh)	4.75	5.94
Field supplied low static drive	Not required	Not required

Mechanical Specifications - Split System Air Conditioning Units (Large)**Item: A1 - A3 Qty: 5 Tag(s): Zone 5 CU, Zone 10 CU, Zone 2 CU, Zone 3 CU, Zone 8 CU****General - TTA**

Weatherproofed Steel Mounting/Lifting Rails
Hermetic Scroll Compressors
Plate Fin Condenser Coils
Fans and Motors
Standard Operating Range 50-125F (Min. 0°F with Low Ambient Accy)
Nitrogen Holding Charge
Certified and Rated in Accordance with AHRI and DOE Standards
Certified to UL 1995

Casing - TTA

Zinc Coated, Heavy Gauge, Galvanized Steel
Weather Resistant Baked Enamel Finish
Meets 672 hr Salt Spray Test
Removable Single Side Maintenance Access Panels
Lifting Handles in Maintenance Access Panels
Unit Base Provisions for Forklift and/or Crane Lifting

Refrigeration System - TTA Dual Compressor

(TTA120E, TTA150E, TTA180E, TTA240E, TTA101E, TTA126E, TTA156E, TTA201E)

Two (2) Separate and Independent Refrigerant Circuits
Each Refrigeration Circuit Equipped with Integral Subcooling Circuit
Two (2) Direct Drive Hermetic Scroll Compressor
Suction Gas-Cooled Motors w/ +/- 10% Voltage Utilization Range of Unit Nameplate Voltage
Crankcase Heaters
Internal Temperature and Current Sensitive Motor Overloads
Factory Installed Liquid Line Filter Driers
Phase Loss/Reverse Rotation Monitor
Liquid Line Service Valves (with gauge port)
Suction Line Service Valves (with gauge port)
No Compressor Suction and/or Discharge Valves (Reduced Vibration/Sound)
External High Pressure Cutout Devices
External Low Pressure Cutout Devices
Evaporator Defrost Control
Loss of Charge Protection (Discharge Temperature Limit)

Condenser Coil - TTA

3/8" Internally Enhanced Copper Tube Mechanically Bonded to Lanced Aluminum Plate Fins
Factory Pressure and Leak Tested to 660 psig.
Perforated Steel Hailguards Available (Factory Installed Option or Field Installed Accessory)

Condenser Fan - TTA

26" or 28" Propeller Fan(s)
Direct Drive
Statically and Dynamically Balanced

Condenser Motor(s) - TTA

Permanently Lubricated Totally Enclosed or Open Construction
Built-In Current and Thermal Overloads
Ball or Sleeve Bearing Type

Controls - TTA

Choice of Electro-mechanical or Microprocessor
Completely Internally Wired
Numbered and Colored Wires
Contactor Pressure Lugs or Terminal Block
Unit External Mounting Location for Disconnect Device
Single Point Power Entry

Unit Dimensions - Split System Air Conditioning Units (Large)

Item: A1 Qty: 2 Tag(s): Zone 5 CU, Zone 10 CU

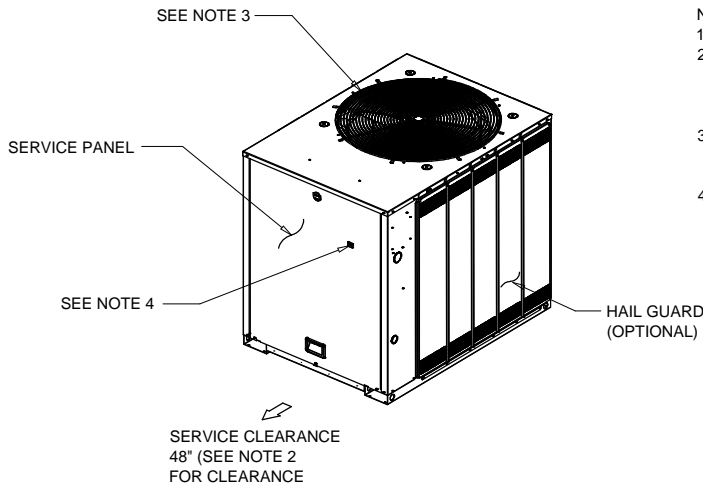

NOTES:

1. ACCESS OPENING IS FOR FIELD INSTALLED BAYLOAM ACCESSORY.
2. MINIMUM CLEARANCE FOR PROPER OPERATION IS 36" FROM WALLS, SHRUBBERY, PRIVACY FENCES ETC. MINIMUM CLEARANCE BETWEEN ADJACENT UNITS IS 72". RECOMMENDED SERVICE CLEARANCE 48"
3. TOP DISCHARGE AREA SHOULD BE UNRESTRICTED FOR 100" MINIMUM. UNIT SHOULD BE PLACED SO ROOF RUN-OFF WATER DOES NOT POUR DIRECTLY ON UNIT
4. OUTDOOR AIR TEMPERATURE SENSOR OPENING (DO NOT BLOCK OPENING).

SERVICE CLEARANCE
48" (SEE NOTE 2
FOR CLEARANCE

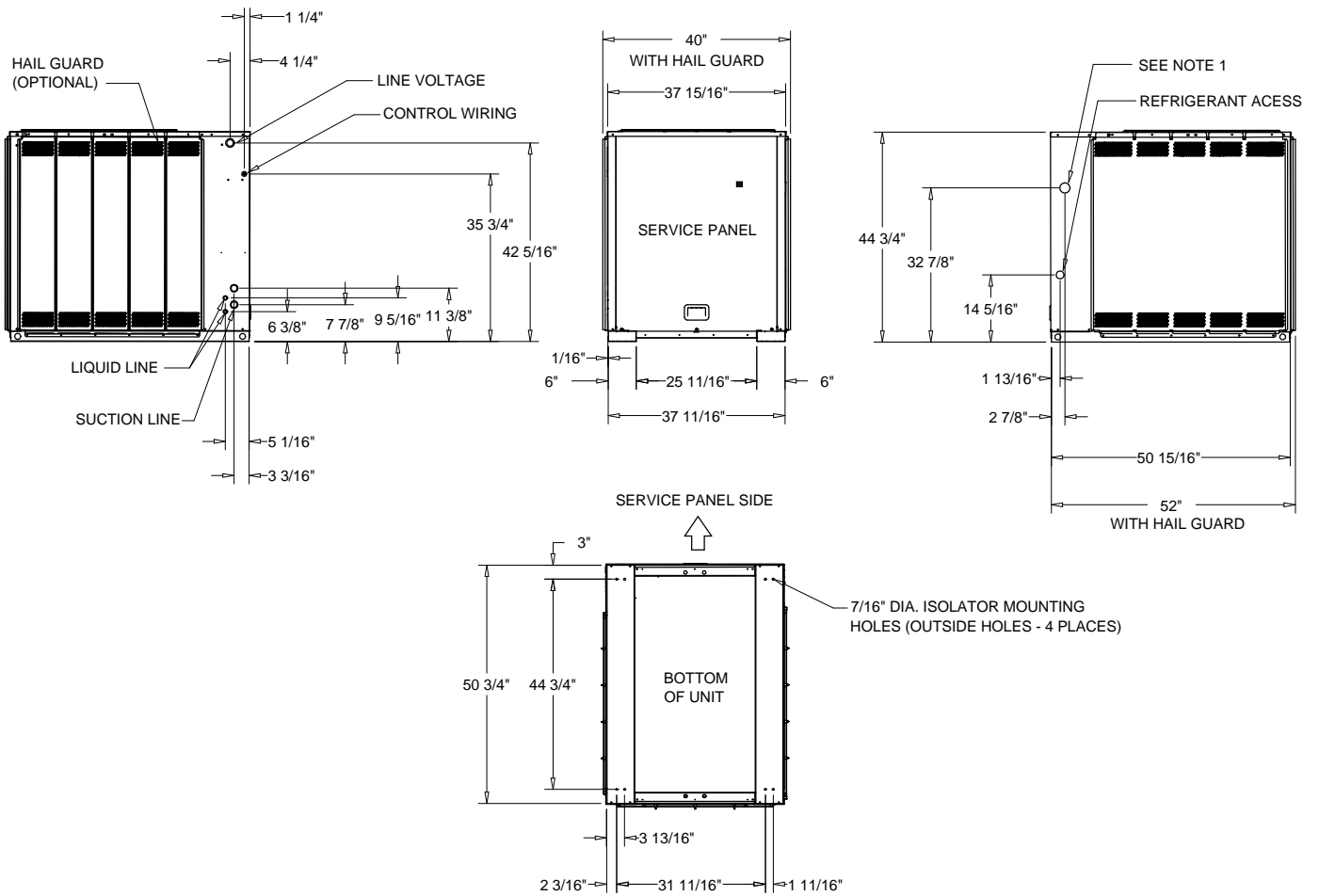

12 1/2 TON COOLING CONDENSER (DUAL COMPRESSOR)
DIMENSIONAL DRAWING

Unit Dimensions - Split System Air Conditioning Units (Large)

Item: A1 Qty: 2 Tag(s): Zone 5 CU, Zone 10 CU

ELECTRICAL DATA CONDENSER

ELECTRICAL DATA Model: TTA150E4 Unit Operating Voltage: 414 - 506 Minimum Circuit Ampacity: 26.4 Maximum Fuse Size: 30.0 Maximum Circuit Breaker: 30.0		COMPRESSOR MOTOR No.: 2 Volts: 460 Phase: 3 Amp-RLA: 10.6 Amp-LRA: 75.0		CONDENSER FAN MOTOR No.: 1 Volts: 460 Phase: 1 Amp-FLA: 2.5 Amp-LRA: 5.8	
GENERAL DATA CONDENSER					
COOLING PERFORMANCE (1)(2)(3)(4)(5) Matched Air Handler: 154,000 Condensing Unit Only: 144,000 ARI Net Cooling Capacity: 150,000 Matched Air Handler: 11.0 Condensing Unit Only: 11.7 System Integrated Part Load Value: 13.4 Condensing Unit Only IPLV: 15.9 System KW: 13.63 Condensing Unit KW: 12.31 IEER: 13.2			COMPRESSOR Number: 2 Motors/HP (each): 5.5 Motor RPM: 3500 No. Compressor / Tons: 2/5.6		
			SYSTEM DATA (7) No. Refrigerant Circuits: 2 Suction Line (in.) OD: 1 1/8" Liquid Line (in.) OD: 1/2"		
OUTDOOR COIL Tube Size (in.) OD: 3/8" Face Area (sq. ft.): 30 5/8" Rows/FPI: 2/18			OUTDOOR FAN No. Used/Diameter (in.): 1 / 28" Drive Type/No. Speeds: DIRECT / 1 CFM: 9,800 No. Motors/HP: 1.0 / 1.0 Motor RPM: 1,100		
REFRIGERANT CHARGE (Fld Supplied) (7)(8) TYPE: R-410A (Circuits #1): 15.3 lb (Circuits #2): 15.4 lb					

NOTES:

- Cooling performance is rated at 95 F ambient, 80 F entering dry bulb, 67 F entering wet bulb. Gross capacity does not include the effect of fan motor heat. AHRI capacity is net and includes the effect of fan motor heat. Ratings shown are tested and certified in accordance with AHRI Standard 340/360 or 365 certification program.
- Standard 340/360 or 365 certification program.
- Condensing Unit Only Gross Cooling Capacity rate at 45 F saturated suction temperature and at 95 F ambient.
- ARI Net Cooling Capacity is calculated with matched blower coil and 25 ft. of OD interconnecting tubing. EER is rated at AHRI conditions and in accordance with DOE test procedures.
- Integrated Part Load Value is based on AHRI Standard 340/360 or 365. Units are rated at 80 F ambient, 80 F entering dry bulb, and 67 F entering wet bulb at AHRI rated CFM.
- Sound Rating shown is tested in accordance with AHRI Standard 270.
- Refer to refrigerant piping program for line sizing and line length.
- Refrigerant (operating) charge is for condensing unit (all circuits) with matching blower coils and 25 ft. of interconnecting refrigerant lines. All units are shipped with a small nitrogen holding charge only.

Unit Dimensions - Split System Air Conditioning Units (Large)

Item: A2 Qty: 2 Tag(s): Zone 2 CU, Zone 3 CU

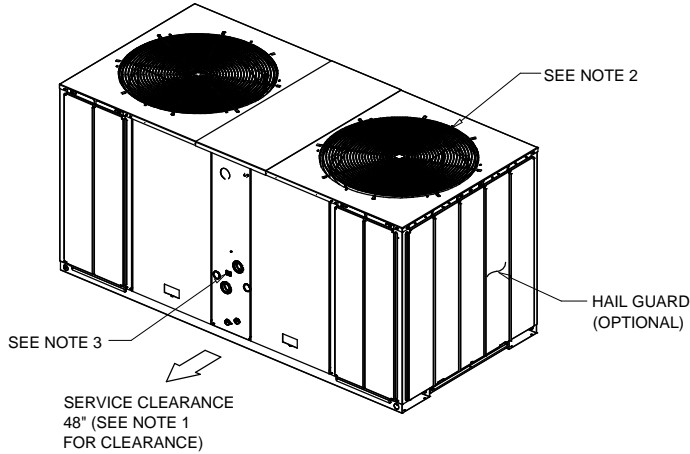

NOTES:

1. MINIMUM CLEARANCE FOR PROPER OPERATION IS 36" FROM WALLS, SHRUBBERY, PRIVACY FENCES ETC. MINIMUM CLEARANCE BETWEEN ADJACENT UNITS IS 72". RECOMMENDED SERVICE CLEARANCE 48"
2. TOP DISCHARGE AREA SHOULD BE UNRESTRICTED FOR 100" MINIMUM. UNIT SHOULD BE PLACED SO ROOF RUN-OFF WATER DOES NOT POUR DIRECTLY ON UNIT
3. OUTDOOR AIR TEMPERATURE SENSOR OPENING (DO NOT BLOCK OPENING)

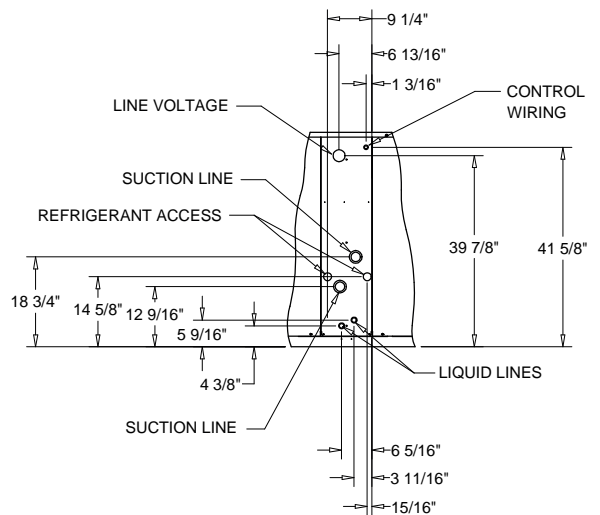
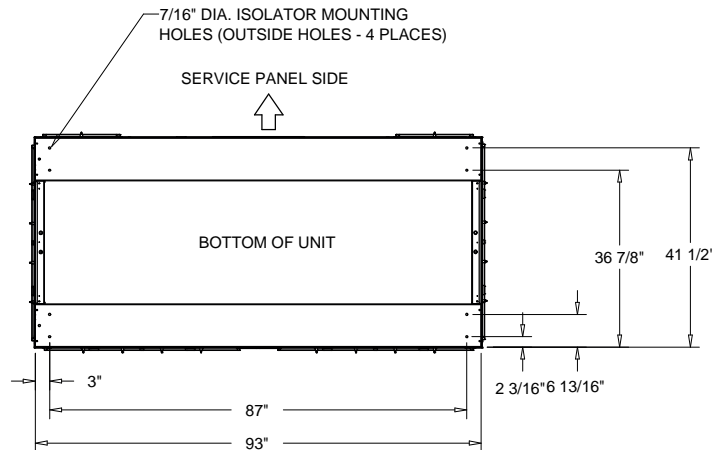
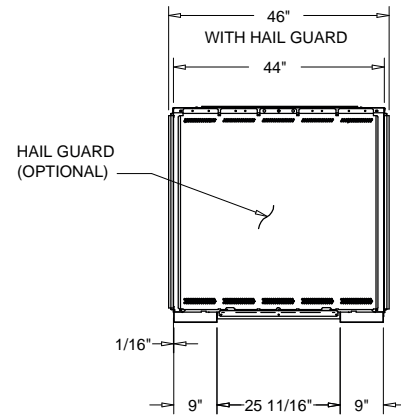
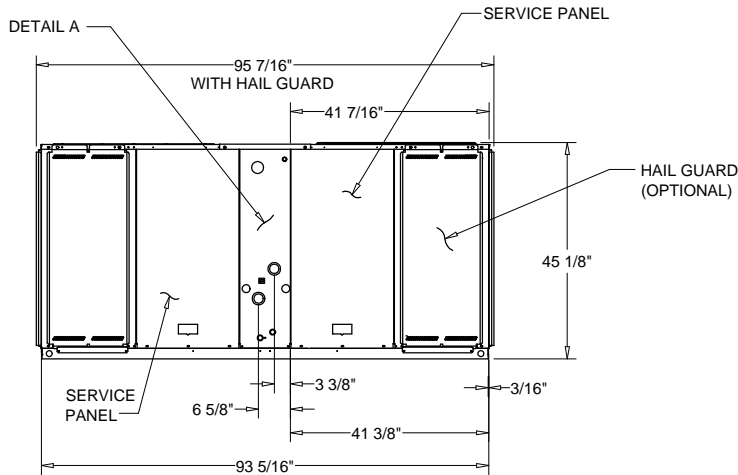

FRONT DETAIL A
DIMENSIONAL DETAIL

15 TON COOLING CONDENSER (DUAL COMPRESSOR)
DIMENSIONAL DRAWING

Unit Dimensions - Split System Air Conditioning Units (Large)

Item: A2 Qty: 2 Tag(s): Zone 2 CU, Zone 3 CU

ELECTRICAL DATA CONDENSER

ELECTRICAL DATA Model: TTA180E4 Unit Operating Voltage: 414 - 506 Minimum Circuit Ampacity: 32.5 Maximum Fuse Size: 40.0 Maximum Circuit Breaker: 40.0		COMPRESSOR MOTOR No.: 2 Volts: 460 Phase: 3 Amp-RLA: 12.2 Amp-LRA: 100.0		CONDENSER FAN MOTOR No.: 2 Volts: 460 Phase: 1 Amp-FLA: 2.5 Amp-LRA: 5.8	
GENERAL DATA CONDENSER					
COOLING PERFORMANCE (1)(2)(3)(4)(5) Matched Air Handler: - Condensing Unit Only: ARI Net Cooling Capacity: Matched Air Handler: Condensing Unit Only: System Integrated Part Load Value: Condensing Unit Only IPLV: System KW Condensing Unit KW: IEER: 12.9			COMPRESSOR Number: 2 Motors/HP (each): 6.9 Motor RPM: 3500 No. Compressor / Tons: 2/6.9 SYSTEM DATA (7) No. Refrigerant Circuits: 2 Suction Line (in.) OD: 1 3/8" Liquid Line (in.) OD: 1/2"		
OUTDOOR COIL Tube Size (in.) OD: 3/8" Face Area (sq. ft.): 52 5/8" Rows/FPI: 2/18			OUTDOOR FAN No. Used/Diameter (in.): 2 / 28" Drive Type/No. Speeds: DIRECT / 1 CFM: 19,500 No. Motors/HP: 2 / 1 Motor RPM: 1,100		
REFRIGERANT CHARGE (Fld Supplied) (7)(8) TYPE: R-410A (Circuits #1): 19.5 lb (Circuits #2): 19.5 lb					

NOTES:

- Cooling performance is rated at 95 F ambient, 80 F entering dry bulb, 67 F entering wet bulb. Gross capacity does not include the effect of fan motor heat. AHRI capacity is net and includes the effect of fan motor heat. Ratings shown are tested and certified in accordance with AHRI Standard 340/360 or 365 certification program.
- Standard 340/360 or 365 certification program.
- Condensing Unit Only Gross Cooling Capacity rate at 45 F saturated suction temperature and at 95 F ambient.
- ARI Net Cooling Capacity is calculated with matched blower coil and 25 ft. of OD interconnecting tubing. EER is rated at AHRI conditions and in accordance with DOE test procedures.
- Integrated Part Load Value is based on AHRI Standard 340/360 or 365. Units are rated at 80 F ambient, 80 F entering dry bulb, and 67 F entering wet bulb at AHRI rated CFM.
- Sound Rating shown is tested in accordance with AHRI Standard 270.
- Refer to refrigerant piping program for line sizing and line length.
- Refrigerant (operating) charge is for condensing unit (all circuits) with matching blower coils and 25 ft. of interconnecting refrigerant lines. All units are shipped with a small nitrogen holding charge only.

Unit Dimensions - Split System Air Conditioning Units (Large)

Item: A3 Qty: 1 Tag(s): Zone 8 CU

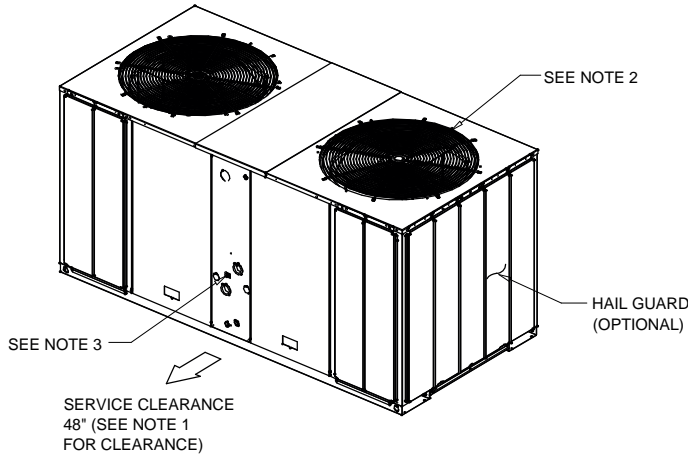

NOTES:

1. MINIMUM CLEARANCE FOR PROPER OPERATION IS 36" FROM WALLS, SHRUBBERY, PRIVACY FENCES ETC. MINIMUM CLEARANCE BETWEEN ADJACENT UNITS IS 72". RECOMMENDED SERVICE CLEARANCE 48"
2. TOP DISCHARGE AREA SHOULD BE UNRESTRICTED FOR 100" MINIMUM. UNIT SHOULD BE PLACED SO ROOF RUN-OFF WATER DOES NOT POUR DIRECTLY ON UNIT
3. OUTDOOR AIR TEMPERATURE SENSOR OPENING (DO NOT BLOCK OPENING)

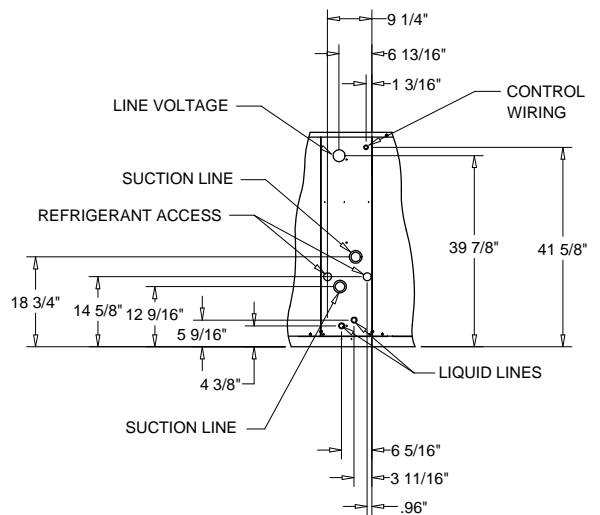
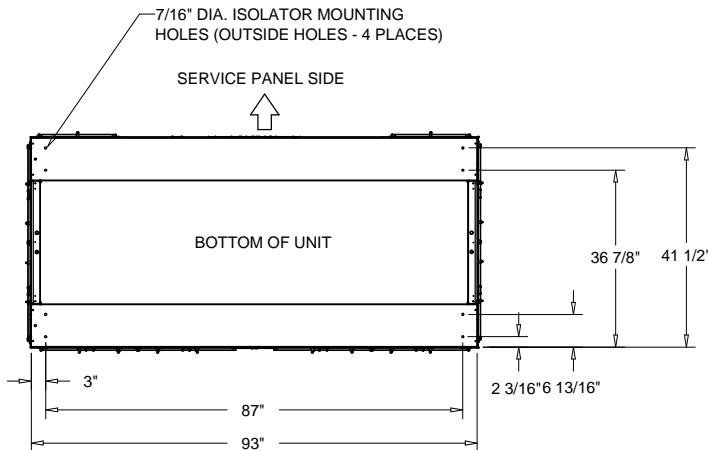
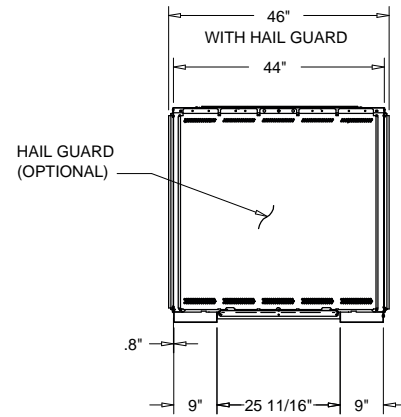
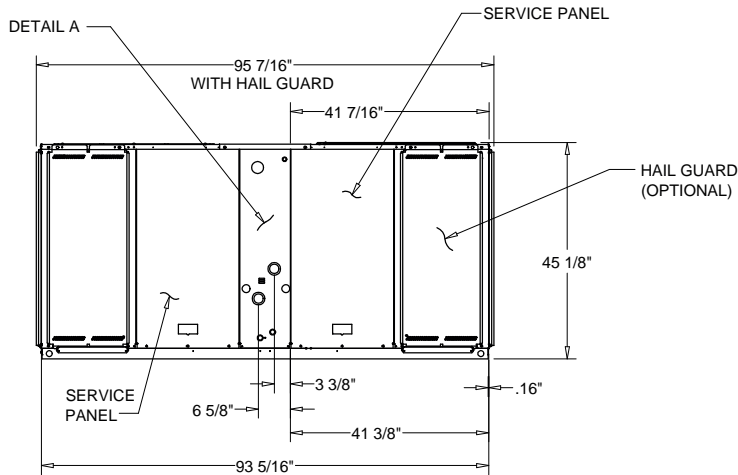

FRONT DETAIL A
DIMENSIONAL DETAIL

20 TON COOLING CONDENSER (DUAL COMPRESSOR)
DIMENSIONAL DRAWING

Unit Dimensions - Split System Air Conditioning Units (Large)

Item: A3 Qty: 1 Tag(s): Zone 8 CU

ELECTRICAL DATA CONDENSER

ELECTRICAL DATA Model: TTA240E4 Unit Operating Voltage: 414 - 506 Minimum Circuit Ampacity: 46.9 Maximum Fuse Size: 60.0 Maximum Circuit Breaker: 60.0		COMPRESSOR MOTOR No.: 2 Volts: 460 Phase: 3 Amp-RLA: 18.6 Amp-LRA: 142.0		CONDENSER FAN MOTOR No.: 2 Volts: 460 Phase: 1 Amp-FLA: 2.5 Amp-LRA: 5.8	
GENERAL DATA CONDENSER					
COOLING PERFORMANCE (1)(2)(3)(4)(5) Matched Air Handler: 263,000 Condensing Unit Only: 270,000 ARI Net Cooling Capacity: 254,000 Matched Air Handler: 10.0 Condensing Unit Only: 12.1 System Integrated Part Load Value: 11.2 Condensing Unit Only IPLV: 15.9 System KW: 25.40 Condensing Unit KW: 22.32 IEER: 10.9			COMPRESSOR Number: 2 Motors/HP (each): 15.0 Motor RPM: 3500 No. Compressor / Tons: 2/10.1		
			SYSTEM DATA (7) No. Refrigerant Circuits: 2 Suction Line (in.) OD: 1 3/8" Liquid Line (in.) OD: 1/2"		
OUTDOOR COIL Tube Size (in.) OD: 3/8" Face Area (sq. ft.): 52 5/8" Rows/FPI: 2/18			OUTDOOR FAN No. Used/Diameter (in.): 2 / 28" Drive Type/No. Speeds: DIRECT / 1 CFM: 19,500 No. Motors/HP: 2 / 1 Motor RPM: 1,100		
REFRIGERANT CHARGE (Fld Supplied) (7)(8) TYPE: R-410A (Circuits #1): 21.9 lb (Circuits #2): 21.9 lb					

NOTES:

- Cooling performance is rated at 95 F ambient, 80 F entering dry bulb, 67 F entering wet bulb. Gross capacity does not include the effect of fan motor heat. AHRI capacity is net and includes the effect of fan motor heat. Ratings shown are tested and certified in accordance with AHRI Standard 340/360 or 365 certification program.
- Standard 340/360 or 365 certification program.
- Condensing Unit Only Gross Cooling Capacity rate at 45 F saturated suction temperature and at 95 F ambient.
- ARI Net Cooling Capacity is calculated with matched blower coil and 25 ft. of OD interconnecting tubing. EER is rated at AHRI conditions and in accordance with DOE test procedures.
- Integrated Part Load Value is based on AHRI Standard 340/360 or 365. Units are rated at 80 F ambient, 80 F entering dry bulb, and 67 F entering wet bulb at AHRI rated CFM.
- Sound Rating shown is tested in accordance with AHRI Standard 270.
- Refer to refrigerant piping program for line sizing and line length.
- Refrigerant (operating) charge is for condensing unit (all circuits) with matching blower coils and 25 ft. of interconnecting refrigerant lines. All units are shipped with a small nitrogen holding charge only.

Weight, Clearance & Rigging Diagram - Split System Air Conditioning Units (Large)

Item: A1 Qty: 2 Tag(s): Zone 5 CU, Zone 10 CU

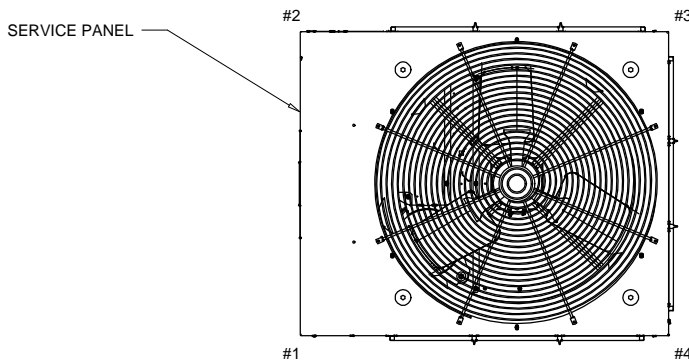
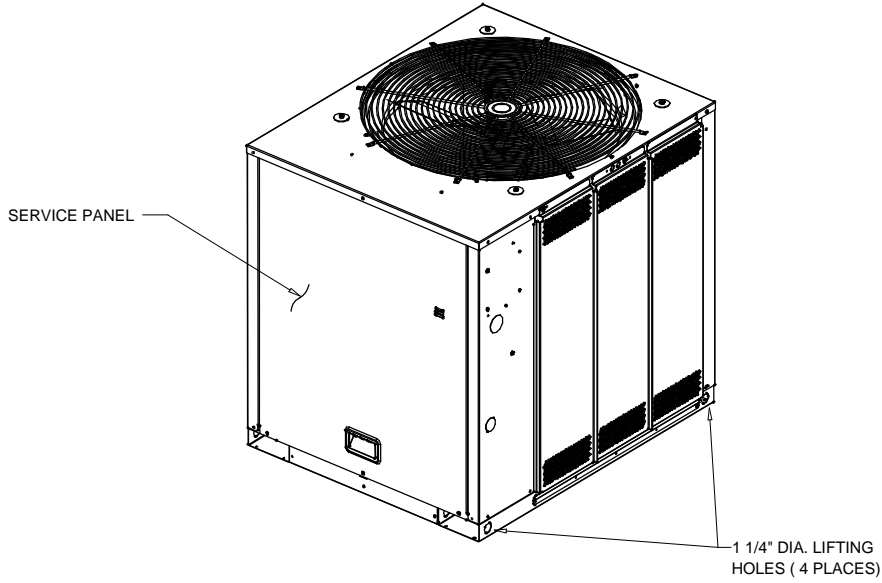

WEIGHTS AND CORNER WEIGHTS

Shipping:	543.0 lb
Net	468.0 lb
Corner 1:	130.0 lb
Corner 2:	151.0 lb
Corner 3:	79.0 lb
Corner 4:	108.0 lb

WEIGHTS AND LOAD POINT LOCATION

WEIGHT AND RIGGING

Weight, Clearance & Rigging Diagram - Split System Air Conditioning Units (Large)

Item: A2 Qty: 2 Tag(s): Zone 2 CU, Zone 3 CU

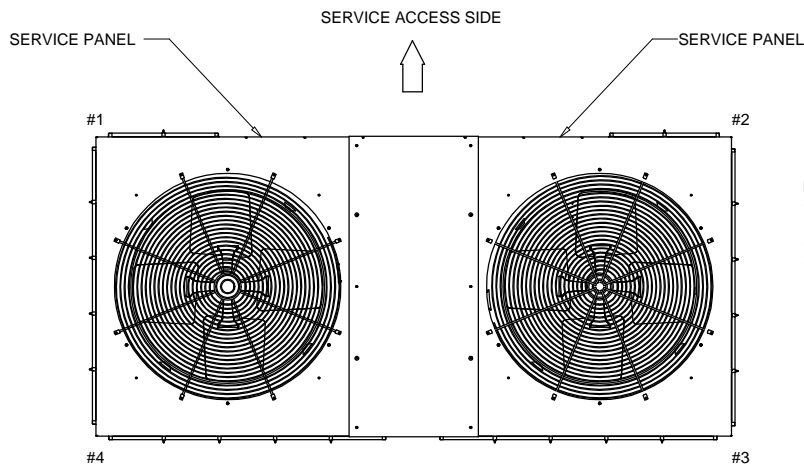
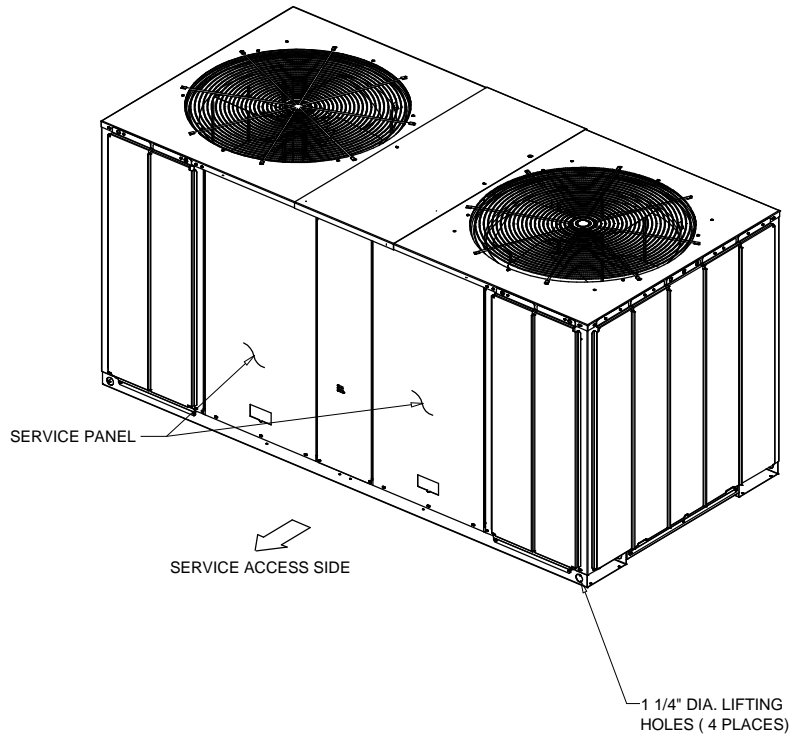

WEIGHTS AND CORNER WEIGHTS

Shipping:	850.0 lb
Net	723.0 lb
Corner 1:	207.0 lb
Corner 2:	204.0 lb
Corner 3:	151.0 lb
Corner 4:	161.0 lb

WEIGHTS AND LOAD POINT LOCATION FOR CONDENSOR

WEIGHT AND RIGGING

Weight, Clearance & Rigging Diagram - Split System Air Conditioning Units (Large)

Item: A3 Qty: 1 Tag(s): Zone 8 CU

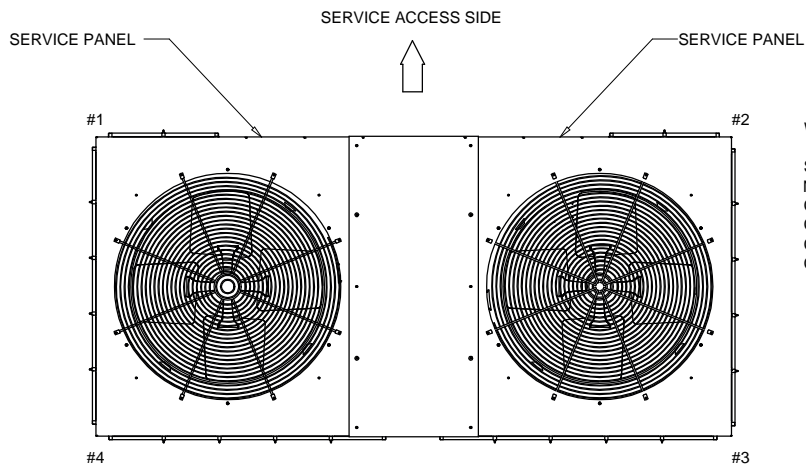
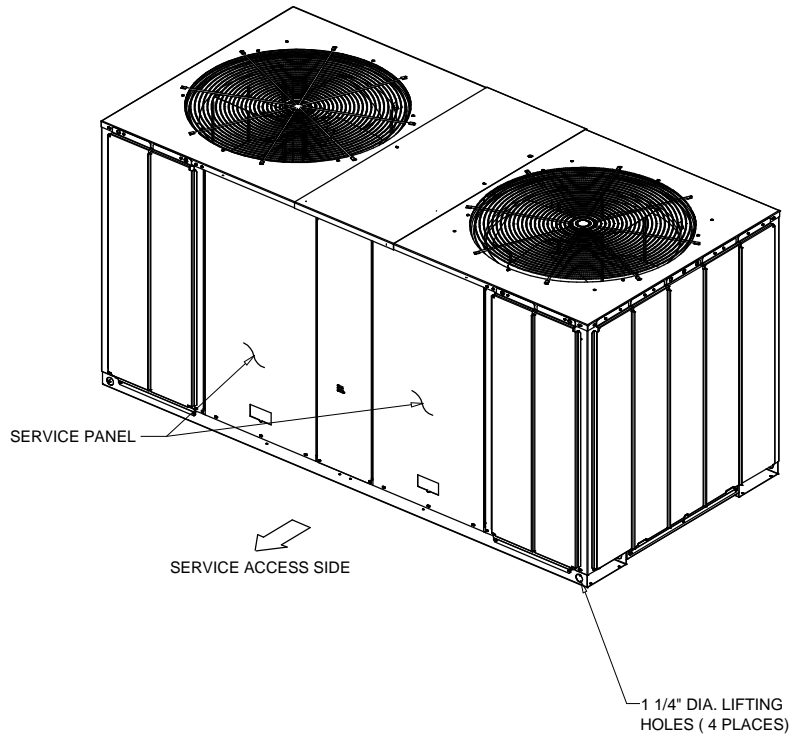

WEIGHTS AND CORNER WEIGHTS

Shipping:	970.0 lb
Net	837.0 lb
Corner 1:	262.0 lb
Corner 2:	240.0 lb
Corner 3:	164.0 lb
Corner 4:	171.0 lb

WEIGHTS AND LOAD POINT LOCATION FOR CONDENSOR

WEIGHT AND RIGGING

Tag Data - Split System Air Conditioning Units (Small) (Qty: 5)

Item	Tag(s)	Qty	Description	Model Number
B1	Zone 1 Split	1	1 - 6 Ton Unitary Split Systems (SSC)	4TTB3024E1000-GAM5A0000M-1S-0---000-0--0
B2	Zone 6 Split	1	1 - 6 Ton Unitary Split Systems (SSC)	4TTA3036A4000-GAM5A0B36M-1S-0---000-0--0
B3	Zone 7 Split	1	1 - 6 Ton Unitary Split Systems (SSC)	4TTA3048A4000-GAM5A0000M-1S-0---000-0--0
B4	Zone 4 Split, Zone 9 Split	2	1 - 6 Ton Unitary Split Systems (SSC)	4TTA3060A4000-GAM5A0C60M-1S-0---000-0--0

Product Data - Split System Air Conditioning Units (Small)**Item: B1 Qty: 1 Tag(s): Zone 1 Split**

Split System Cooling Outdoor Unit
 2 Ton Nominal Cooling Capacity
 200 - 230 Volt 1 Phase 60 Hertz
 Good
 Multi-poise 4-way
 Better, Entry level Hi EFF, multispeed
 Major designs sequence
 17.5 x 21.5
 2 Ton air handler
 Mid EFF Multi-speed
 Power Supply
 System Control Type
 5.77/7.68 kW Electric Htr w/ Ckt Brk for 208/240V 1 Phase 60 Hz (Fld)

Item: B2 Qty: 1 Tag(s): Zone 6 Split

Split System Cooling Outdoor Unit
 3 Ton Nominal Cooling Capacity
 460 Volt 3 Phase 60 Hertz
 Good
 Multi-poise 4-way
 Better, Entry level Hi EFF, multispeed
 Major designs sequence
 21.0 x 21.5
 3 Ton air handler
 Mid EFF Multi-speed
 Power Supply
 System Control Type
 7.21/9.60 kW Electric Htr w/Ckt Brk for 208/240V 1 Phase 60 Hz (Fld)

Item: B3 Qty: 1 Tag(s): Zone 7 Split

Split System Cooling Outdoor Unit
 4 Ton Nominal Cooling Capacity
 460 Volt 3 Phase 60 Hertz
 Good
 Multi-poise 4-way
 Better, Entry level Hi EFF, multispeed
 Major designs sequence
 23.5 x 21.5
 4 Ton air handler
 Mid EFF Multi-speed
 Power Supply
 System Control Type
 7.21/9.60 kW Electric Htr w/Ckt Brk for 208/240V 1 Phase 60 Hz (Fld)

Item: B4 Qty: 2 Tag(s): Zone 4 Split, Zone 9 Split

Split System Cooling Outdoor Unit
 5 Ton Nominal Cooling Capacity
 460 Volt 3 Phase 60 Hertz
 Good

Multi-poise 4-way
 Better, Entry level Hi EFF, multispeed
 Major designs sequence
 23.5 x 21.5
 5 Ton air handler
 Mid EFF Multi-speed
 Power Supply
 System Control Type

Performance Data - Split System Air Conditioning Units (Small)

Tags	Zone 1 Split	Zone 6 Split	Zone 7 Split, Zone 4 Split, Zone 9 Split
Design clg outdoor DB (F)	95.00	95.00	95.00
Cooling EDB (F)	80.00	80.00	80.00
Cooling EWB (F)	67.00	67.00	67.00
Rated gross capacity (AHRI) (Btuh)	24000.00	36600.00	48000.00
Clg net total capacity (Btuh)	24300.00	37300.00	49000.00
Clg net sensible capacity (Btuh)	17900.00	27100.00	36200.00
Clg net latent capacity (Btuh)	6400.00	10200.00	12800.00
Calc clg LDB (F)	59.00	58.80	58.70
Calc clg LWB (F)	57.00	56.80	57.00
SEER @ AHRI (btuh/watt)	14.00	14.50	14.50
EER @ AHRI (EER)	11.5	12.0	12.0
Cooling airflow (cfm)	800	1200	1600
Min system airflow clg (cfm)	700	1050	1400
Max system airflow clg (cfm)	900	1350	1800
AHRI airflow (cfm)	750	1080	1430
AHRI reference number ()	4935992	4150764	4150778
Compressor power @ (specific Ambient) (W)	1758.0	2720.0	3396.0
Condenser fan power @ (specific SP) (W)	128.0	150.0	249.0
Supply fan power @ (specified SP) (W)	201.0	180.0	355.0
ASHRAE 90.1 S6.4.1 compliant	Yes	Yes	Yes
Blower capability	2.0 ton to 2.5 ton airflow	3.0 ton to 3.5 ton airflow	3.5 ton to 4.0 ton airflow
80 to 90 second blower off delay	Not Required	Not Required	Not Required
OD AHRI Model (Each)	-1.00	-1.00	-1.00

Mechanical Specifications - Split System Air Conditioning Units (Small)**Item: B1 - B4 Qty: 5 Tag(s): Zone 1 Split, Zone 6 Split, Zone 7 Split, Zone 4 Split, Zone 9 Split****4TTA3 - General**

This unit is fully charged from the factory for matched indoor section and up to 180" of piping. Unit is designed to operate at outdoor ambient temperatures as high as 115.0 F]. Cooling capacities matched with a wide selection of air handlers and furnace coils that are A.R.I certified. The unit shall be UL listed. Exterior must be designed for outdoor application.

4TTA3 - Casing

Unit casing is constructed of heavy gauge, galvanized steel and painted with a weather-resistant powder paint. Corrosion and weatherproof CMBP-G30 Duratuff base.

4TTA3 - Compressor

The Climatuff compressor features internal over temperature and pressure protector, total dipped hermetic motor. Other features include: centrifugal oil pump, and low vibration and noise.

4TTA3 - Condenser Coil

The Spine Fin coil is continuously wrapped, corrosion resistant, all aluminum with minimum brazed joints. The coil is 3/8" O.D. seamless aluminum glued to a continuous aluminum fin. Coils are lab tested to withstand 2000.0 lb of pressure per square inch. The outdoor coil provides low airflow resistance and efficient heat transfer.

4TTA3 - Refrigerant controls

Refrigeration system controls include condenser fan and compressor contactor. High and low pressure protection is inherent to the compressor. Another standard feature is the factory installed liquid line drier.

GAM5

Air-Tite II cabinet

2% or less air leakage

Precision applied - durable door seals

Specially designed air seal around refrigerant, condensate and conduit connections

Double wall foamed cabinet system

R-4.2 insulating value

No loose fiber design

Smooth cleanable interior design

Sweat eliminating design

Composite foamed cabinet doors

Water proof cabinet design

Integrated horizontal drain pans

Modular cabinet with " allen wrench "quick latch" design

Multi-position up/down flow horizontal left/right

Side return option

Control board protection pocket built into cabinet wall

Alert port to view control board codes without door removal

10 alert codes

Low voltage terminal connection point

Quarter turn phillips head door fasteners

Vortica blower with polarized plug connections and integrated slide deck for easy removal

Aluminum coil with integrated slide deck for easy removal and polarized plug connections on coil EEV

Patented enhanced coil fin

Electronic Expansion Valve (EEV) with low ambi-ent and low superheat compressor protection

Dual refrigerant compatible as shipped

Slide in electric heaters with polarized plug connections (sold as accessory)

UVC light kit with safety switch and polarized plug connections (sold as accessory)

Labeled panels and connections

Molded in 1" standard filter rail

High efficiency ECM motor

Soft start fan motor operation

Built in fan delay modes

Maximum width of 23 1/2"

Compact 20 13/16" depth with doors removed

Two tone color

Fused 24v power
Safety door switch
1-year warranty
10-year warranty registered
Optional extended warranty available

Heater Section - 1 Phase Vertical Air Handler

A compartment is provided in the blower section for field installation of supplementary heater. Polarized plugs are provided for making electrical connections to the air handler control box from the supplementary heater.

4TTB3 - General

This unit is fully charged from the factory for matched indoor section and up to 180" of piping. Unit is designed to operate at outdoor ambient temperatures as high as 115.0 F. Cooling capacities matched with a wide selection of air handlers and furnace coils that are A.R.I certified. The unit shall be UL listed. Exterior must be designed for outdoor application.

4TTB3 - Casing

Unit casing is constructed of heavy gauge, galvanized steel and painted with a weather-resistant powder paint. Corrosion and weatherproof CMBP-G30 Duratuff base.

4TTB3 - compressor

The Climatuff compressor features internal over temperature and pressure protection and total dipped hermetic motor. Other features include: centrifugal oil pump and low vibration and noise.

4TTB3 - Condenser Coil

The Spine Fin coil is continuously wrapped, corrosion resistant, all aluminum with minimum brazed joints. The coil is 3/8" O.D. seamless aluminum glued to a continuous aluminum fin. Coils are lab tested to withstand 2000.0 lbof pressure per square inch. The outdoor coil provides low airflow resistance and efficient heat transfer.

4TTB3 - Refrigerant controls

Refrigeration system controls include condenser fan and compressor contactor. High and low pressure protection is inherent to the compressor. Another standard feature is the factory installed liquid line drier

Unit Dimensions - Split System Air Conditioning Units (Small)

Item: B1 Qty: 1 Tag(s): Zone 1 Split

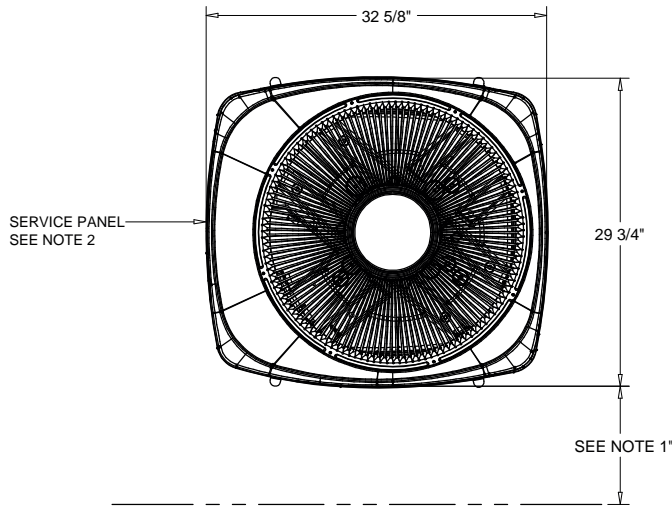

UNIT DIMENSTIONS	
DIM - D	5/8"
DIM - E	3/8"

NOTES

1. TOP DISCHARGE AREA SHOULD BE UNRESTRICTED FOR AT LEAST 60" ABOVE UNIT. UNIT SHOULD BE PLACED SO ROOF RUN-OFF WATER DOES NOT POUR DIRECTLY ON UNIT, AND SHOULD BE AT LEAST 12" FROM WALL AND ALL SURROUNDING SHRUBBERY ON TWO SIDES. OTHER TWO SIDES UNRESTRICTED.
2. ELECTRICAL AND REFRIGERANT COMPONENT CLEARANCES PER PREVAILING CODES.

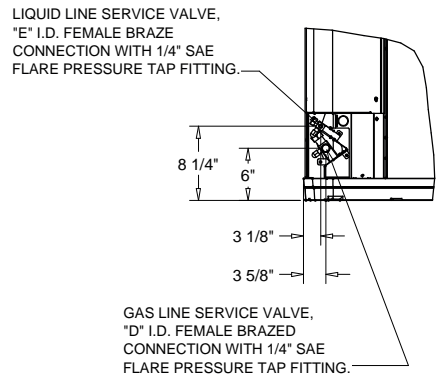
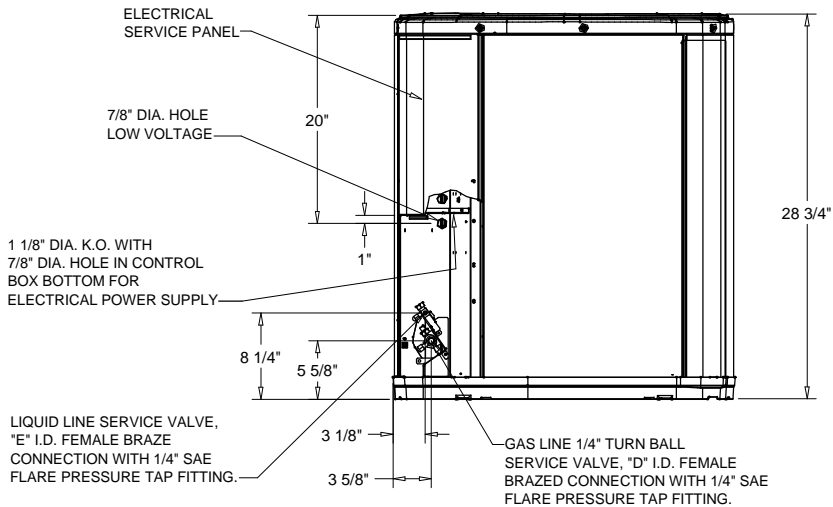

4TTB3024 - COOLING
PLAN VIEW DRAWING

Unit Dimensions - Split System Air Conditioning Units (Small)

Item: B1 Qty: 1 Tag(s): Zone 1 Split

ELECTRICAL / GENERAL DATA

<p>GENERAL</p> <p>Model: 4TTB3024 Voltage: 208 - 230 Unit Hertz: 60 Unit Phase: 1</p>	<p>POWER CONN.</p> <p>Minimum Circuit Ampacity: 11.0 Maximum Circuit Breaker: 15.0 Minimum Protection Rating: 15.0</p>	<p>COMPRESSOR</p> <p>Number: 1 Phase: 1 Rated Load Amps: 8.3 Locked Rotor Amps: 58.0</p>
<p>OUTDOOR MOTOR</p> <p>Number: 1 Horsepower: 0.125 Motor Speed (RPM): 825 Phase: 1 Full Load Amps: 0.74 Locked Rotor Amps: -</p>	<p>NOTES:</p> <p>1. Certified in accordance with the Unitary Air-Conditioner equipment certification program which is based on AHRI Standard 210/240.</p> <p>2. Calculated in accordance with N.E.C. Use only HACR circuit breakers or fuses.</p> <p>3. Standard line lengths - 60'. Standard lift - 60' Suction and Liquid line. For Greater lengths and lifts refer to refrigerant piping software Pub# 32-3312-0</p> <p>4. * = 15, 20, 25, 30, 40 and 50 foot lineset available.</p>	
<p>REFRIGERANT</p> <p>Type: R-410 Charge: 5.2 lb Line Size O.D. Gas: 5/8" Line Size O.D. LIQ: 3/8"</p>		

WEIGHT	
NET	169.0 lb
SHIPPING	196.0 lb

- NOTES:**
- C1. TOP DISCHARGE SHOULD BE UNRESTRICTED FOR AT LEAST 60" ABOVE UNIT
 - C2. PLACE UNIT FROM WALL
 - C3. PLACE SHRUBBERY AT LEAST 12" FROM UNIT ON TWO SIDES, OTHER SIDES UNRESTRICTED
 - C4. PLACE UNIT SO ROOF RUN-OFF DOES NOT FALL DIRECTLY ON UNIT

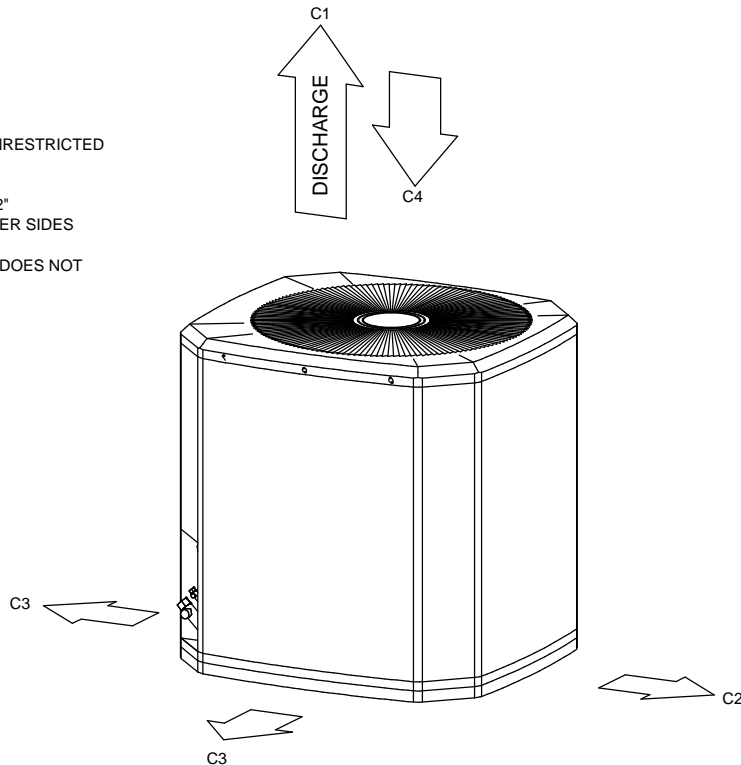

WEIGHT AND CLEARANCE

Unit Dimensions - Split System Air Conditioning Units (Small)

Item: B1 Qty: 1 Tag(s): Zone 1 Split

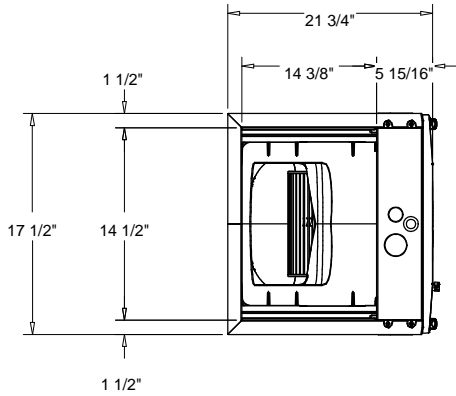

NOTES:

1. BADGE ROTATION WILL KEEP BRAND IN CORRECT POSITION.
2. NO INTERNAL MODIFICATIONS REQUIRED FOR ANY POSITION.
3. VERIFY WEIGHT, CONNECTION, AND ALL DIMENSION WITH INSTALLER DOCUMENTS BEFORE INSTALLATION
4. GAM5 AIR HANDLERS ARE ALL TWO PIECE CABINETS.
5. SEE WEIGHT AND RIGGING PAGE FOR CONDENSATE DRAIN CONFIGURATION

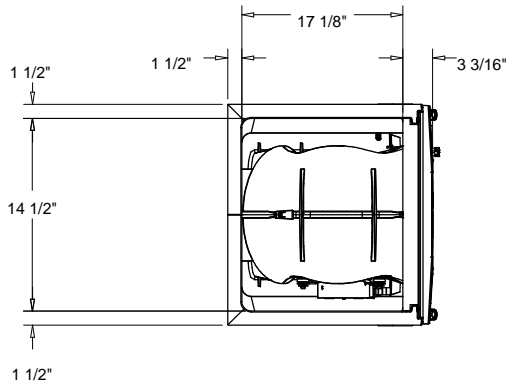
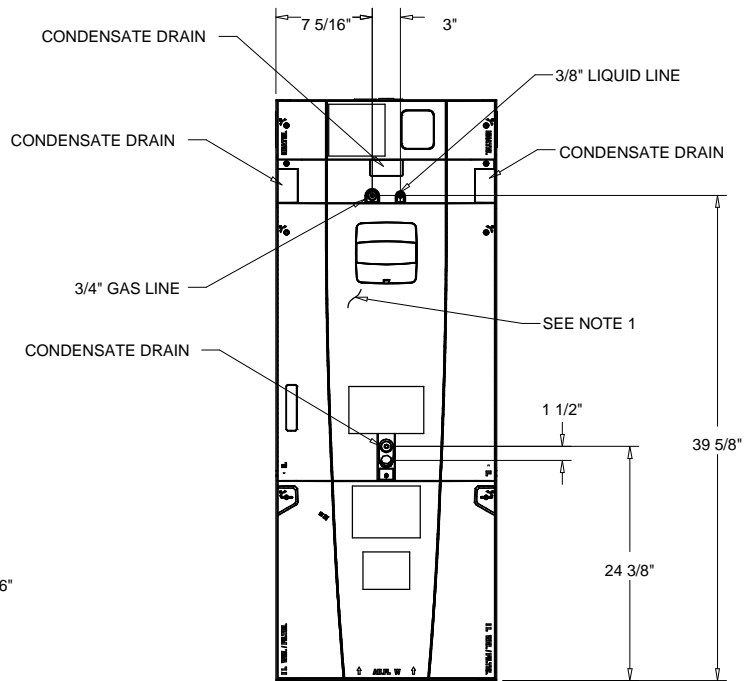
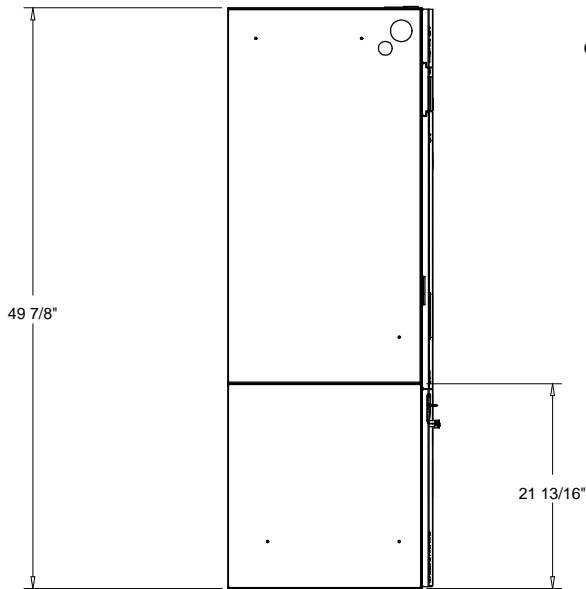

GAM5A0A18 & 24 AIR HANDLER- COOLING

UNIT DIMENSION DRAWING

Unit Dimensions - Split System Air Conditioning Units (Small)

Item: B1 Qty: 1 Tag(s): Zone 1 Split

ELECTRICAL / GENERAL DATA

<p>GENERAL ⁽¹⁾⁽²⁾⁽⁴⁾</p> <p>Model: GAM5A0A24M21SA</p> <p>Unit Primary Voltage: 208 Unit Secondary Voltage: 230 Unit Hertz: 60 Unit Phase: 1</p>	<p>INDOOR MOTOR ⁽¹⁾</p> <p>Number: 1 Horsepower: 0.33 Motor Speed (RPM): 1050 Phase: 1 Full Load Amps: 2.8 Locked Rotor Amps: -</p>	<p>FILTERS ⁽³⁾</p> <p>Type: Throwaway Furnished: No Number: 1 Recommended: 16"x20"x1"</p>
<p>STANDARD ⁽⁵⁾</p> <p>230 Volt / 208 Volt</p> <p>Minimum Circuit Ampacity: 4.0/4.0 Maximum Overload Protection: 15.0/15.0</p>	<p>REFRIGERANT</p> <p>Type: R410 REF. Line Connections: Brazed Coupling or Conn. Size - Gas: 3/4" Coupling or Conn. Size - Liq.: 3/8"</p>	<p>Weights</p> <p>Net: 120.0 lb Shipping: 126.0 lb</p>
<p>ELECTRIC HEAT</p> <p>230 Volt / 208 Volt</p> <p>Capacity Circuit #1: 7.68kW/5.76kW Capacity Circuit #2: N/A Capacity Circuit #3: N/A</p> <p># of Circuit: 1 Phase: 1</p> <p>Heater Amps Per Circuit Circuit #1: 32.0/27.70 Heater Amps Per Circuit Circuit #2: N/A Heater Amps Per Circuit Circuit #3: N/A</p> <p>Minimum Circuit Ampacity Circuit #1: 44.0/38.0 Minimum Circuit Ampacity Circuit #2: N/A Minimum Circuit Ampacity Circuit #3: N/A</p> <p>Maximum Overload Protection Circuit #1: 45.0/40.0 Maximum Overload Protection Circuit #2: N/A Maximum Overload Protection Circuit #3: N/A</p>	<p>NOTES:</p> <ol style="list-style-type: none"> 1. These air handlers are a.r.i. certified with various split system air conditioners and heat pumps (ari standard 210/240). refer to the split system outdoor unit product data guides for performance data. 2. 3/4" male plastic pipe (ref.: astm 1785-76) 3. Minimum filter size for horizontal applications will be based on airflow selection and will be calculated as follows: low velocity filter: face area (sq. ft.) = cfm / 300 high velocity filter: face area (sq. ft.) = cfm / 500 4. For customer ease of filter maintenance, it is recommended that a properly sized, remote filter and grille be installed for horizontal applications. airflow should not exceed the face value of the filter being used 5. Standard mca and mop without electric heat. 	

Unit Dimensions - Split System Air Conditioning Units (Small)

Item: B2 Qty: 1 Tag(s): Zone 6 Split

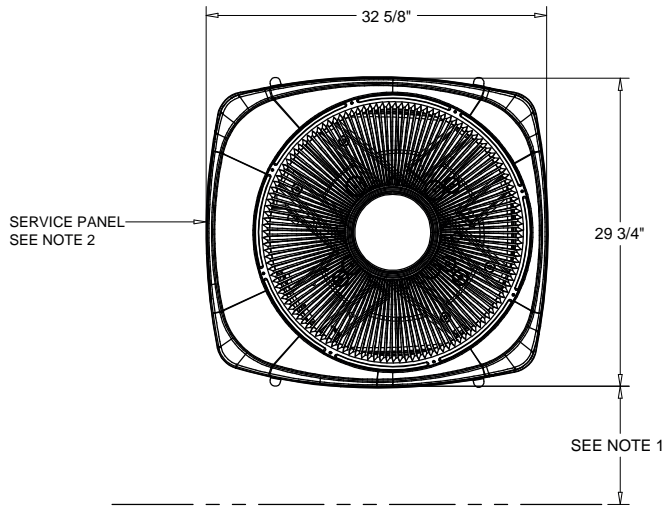

UNIT DIMENSTIONS	
DIM - D	3/4"
DIM - E	5/16"

NOTES

1. TOP DISCHARGE AREA SHOULD BE UNRESTRICTED FOR AT LEAST 60" ABOVE UNIT. UNIT SHOULD BE PLACED SO ROOF RUN-OFF WATER DOES NOT POUR DIRECTLY ON UNIT, AND SHOULD BE AT LEAST 12" FROM WALL AND ALL SURROUNDING SHRUBBERY ON TWO SIDES. OTHER TWO SIDES UNRESTRICTED.
2. ELECTRICAL AND REFRIGERANT COMPONENT CLEARANCES PER PREVAILING CODES.

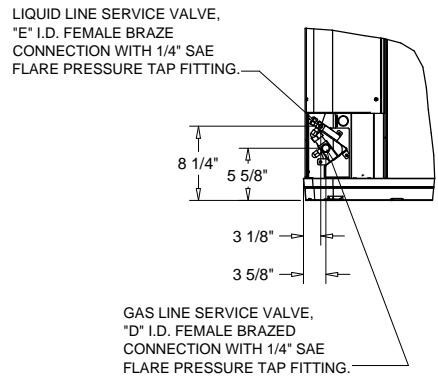
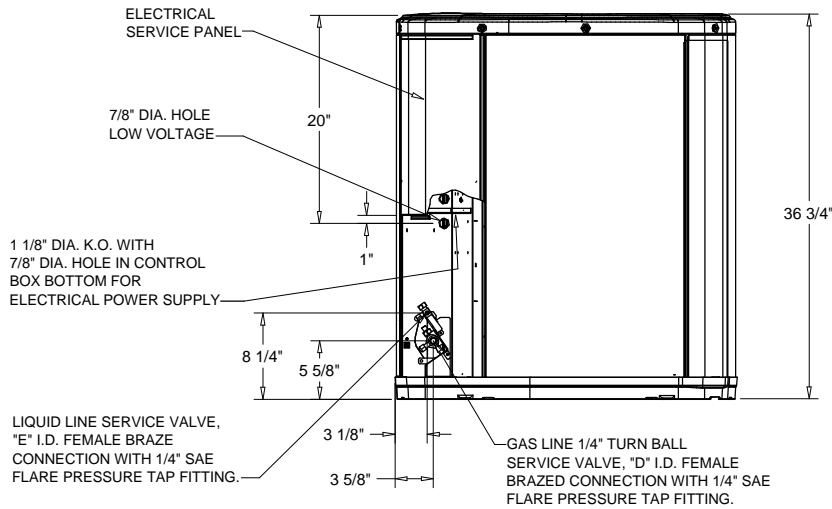

Unit Dimensions - Split System Air Conditioning Units (Small)

Item: B2 Qty: 1 Tag(s): Zone 6 Split

ELECTRICAL / GENERAL DATA

<p>GENERAL</p> <p>Model: 4TTA3036*</p> <p>Operating Voltage: 414-506</p> <p>Unit Primary Voltage: 460</p> <p>Unit Secondary Voltage: -</p> <p>Unit Hertz: 60</p> <p>Unit Phase: 3</p>	<p>POWER CONN.</p> <p>Minimum Circuit Ampacity: 7.0</p> <p>Maximum Circuit Breaker: 15.0</p> <p>Minimum Protection Rating: 15.0</p>	<p>COMPRESSOR</p> <p>Number: 1</p> <p>Phase: 3</p> <p>Rated Load Amps: 5.1</p> <p>Locked Rotor Amps: 35.0</p>
<p>OUTDOOR MOTOR</p> <p>Number: 1</p> <p>Horsepower: 0.125</p> <p>Motor Speed (RPM): 825</p> <p>Phase: 3</p> <p>Full Load Amps: 0.4</p> <p>Locked Rotor Amps: -</p>	<p>NOTES:</p> <p>1. Certified in accordance with the Unitary Air-Conditioner equipment certification program which is based on AHRI Standard 210/240.</p> <p>2. Calculated in accordance with N.E.C. Use only HACR circuit breakers or fuses.</p> <p>3. Standard line lengths - 60'. Standard lift - 60' Suction and Liquid line. For Greater lengths and lifts refer to refrigerant piping software Pub# 32-3312-0</p> <p>4. * = 15, 20, 25, 30, 40 and 50 foot lineset available.</p>	
<p>REFRIGERANT</p> <p>Type: R-410</p> <p>Charge: 6.7 lb</p> <p>Line Size O.D. Gas: 3/4"</p> <p>Line Size O.D. LIQ: 3/8"</p>		

WEIGHT	
NET	201.0 lb
SHIPPING	229.0 lb

- NOTES:**
- C1. TOP DISCHARGE SHOULD BE UNRESTRICTED FOR AT LEAST 60" ABOVE UNIT
 - C2. PLACE UNIT FROM WALL
 - C3. PLACE SHRUBBERY AT LEAST 12" FROM UNIT ON TWO SIDES, OTHER SIDES UNRESTRICTED
 - C4. PLACE UNIT SO ROOF RUN-OFF DOES NOT FALL DIRECTLY ON UNIT

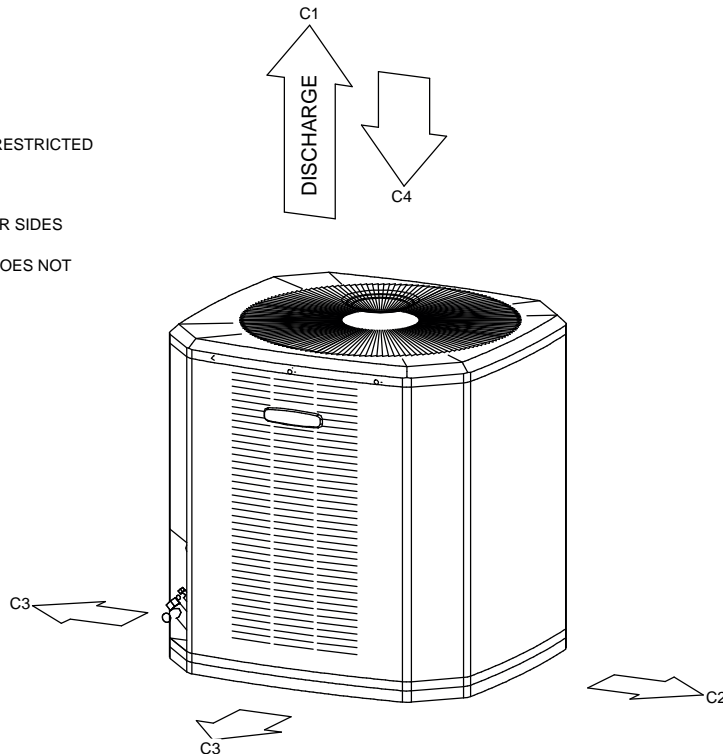

WEIGHT AND CLEARANCE

Unit Dimensions - Split System Air Conditioning Units (Small)

Item: B2 Qty: 1 Tag(s): Zone 6 Split

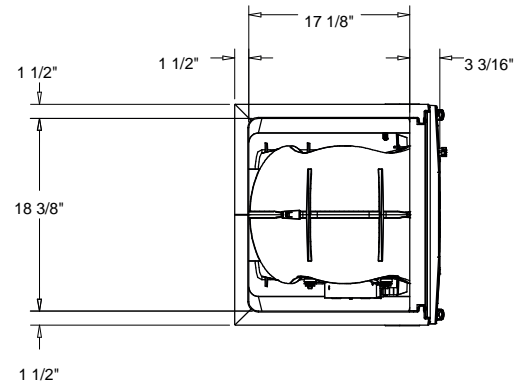
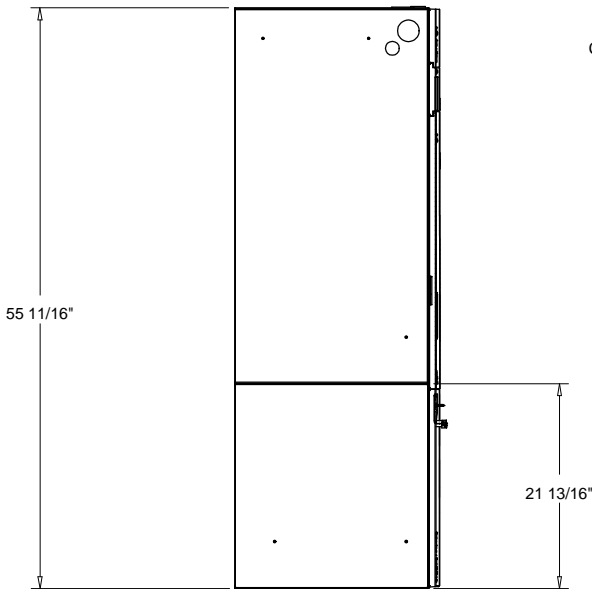
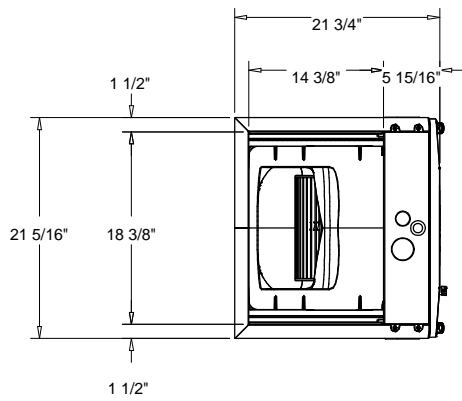

NOTES:

1. BADGE ROTATION WILL KEEP BRAND IN CORRECT POSITION.
2. NO INTERNAL MODIFICATIONS REQUIRED FOR ANY POSITION.
3. VERIFY WEIGHT, CONNECTION, AND ALL DIMENSION WITH INSTALLER DOCUMENTS BEFORE INSTALLATION
4. GAM5 AIR HANDLERS ARE ALL TWO PIECE CABINETS.
5. SEE WEIGHT AND RIGGING PAGE FOR CONDENSATE DRAIN CONFIGURATION

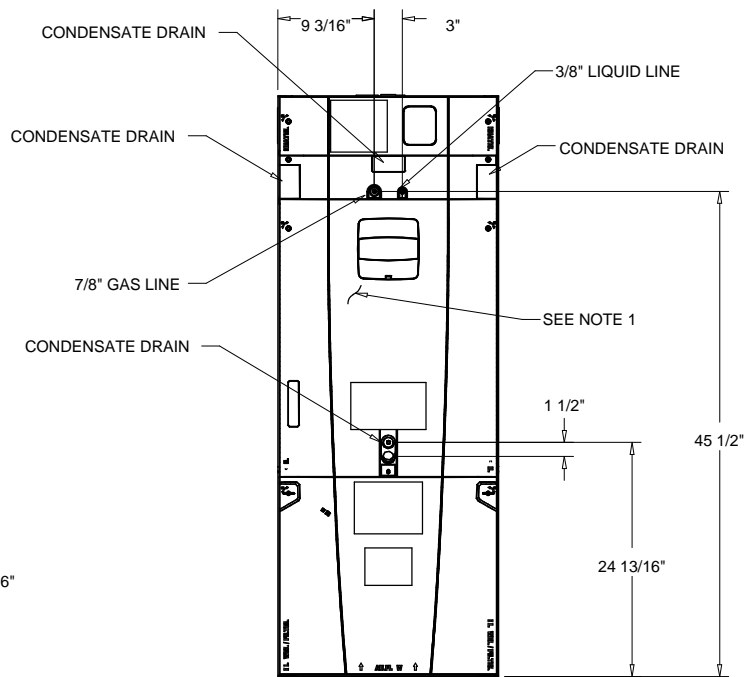

GAM5A0A36 AIR HANDLER- COOLING

UNIT DIMENSION DRAWING

Unit Dimensions - Split System Air Conditioning Units (Small)

Item: B2 Qty: 1 Tag(s): Zone 6 Split

ELECTRICAL / GENERAL DATA

<p>GENERAL ⁽¹⁾⁽²⁾⁽⁴⁾</p> <p>Model: GAM5A0B36M31SA</p> <p>Unit Primary Voltage: 208 Unit Secondary Voltage: 230 Unit Hertz: 60 Unit Phase: 1</p>	<p>INDOOR MOTOR ⁽¹⁾</p> <p>Number: 1 Horsepower: 0.5 Motor Speed (RPM): 1050 Phase: 1 Full Load Amps: 4.1 Locked Rotor Amps:</p>	<p>FILTERS ⁽³⁾</p> <p>Type: Throwaway Furnished: No Number: 1 Recommended: 20"x20"x1"</p>
<p>STANDARD ⁽⁵⁾</p> <p>230 Volt / 208 Volt</p> <p>Minimum Circuit Ampacity: 5.0/5.0 Maximum Overload Protection: 15.0/15.0</p>	<p>REFRIGERANT</p> <p>Type: R410 REF. Line Connections: Brazed Coupling or Conn. Size - Gas: 7/8" Coupling or Conn. Size - Liq.: 3/8"</p>	<p>Weights</p> <p>Net: 142.0 lb Shipping: 150.0 lb</p>
<p>ELECTRIC HEAT</p> <p>230 Volt / 208 Volt</p> <p>Capacity Circuit #1: 9.60kW/7.20kW Capacity Circuit #2: N/A Capacity Circuit #3: N/A</p> <p># of Circuit: 1 Phase: 1</p> <p>Heater Amps Per Circuit Circuit #1: 40.0/34.60 Heater Amps Per Circuit Circuit #2: N/A Heater Amps Per Circuit Circuit #3: N/A</p> <p>Minimum Circuit Ampacity Circuit #1: 55.0/48.0 Minimum Circuit Ampacity Circuit #2: N/A Minimum Circuit Ampacity Circuit #3: N/A</p> <p>Maximum Overload Protection Circuit #1: 60.0/50.0 Maximum Overload Protection Circuit #2: N/A Maximum Overload Protection Circuit #3: N/A</p>	<p>NOTES:</p> <ol style="list-style-type: none"> 1. These air handlers are a.r.i. certified with various split system air conditioners and heat pumps (ari standard 210/240). refer tothesplit system outdoor unit product data guides for performance data. 2. 3/4" male plastic pipe (ref.: astm 1785-76) 3. Minimum filter size for horizontal applications will be based on airflow selection and will be calculated as follows: low velocity filter: face area (sq. ft.) = cfm / 300 high velocity filter: face area (sq. ft.) = cfm / 500 4. For customer ease of filter maintenance, it is recommended that a properly sized, remote filter and grille be installed for horizontal applications. airflow should not exceed the face value of the filter being used 5. Standard mca and mop without electric heat. 	

Unit Dimensions - Split System Air Conditioning Units (Small)

Item: B3 Qty: 1 Tag(s): Zone 7 Split

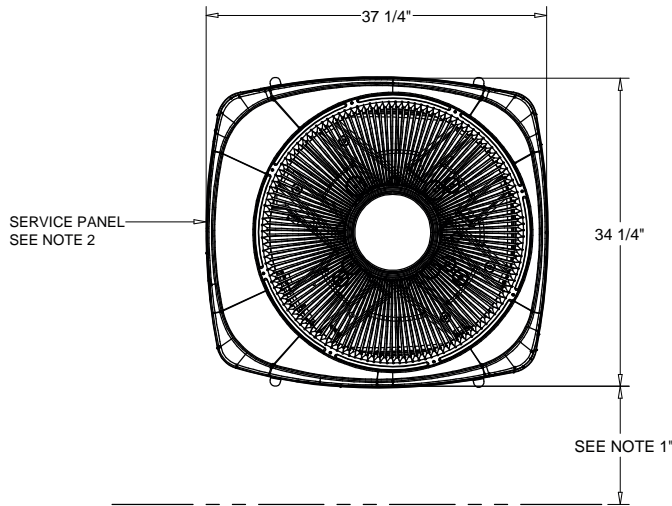

UNIT DIMENSTIONS	
DIM - D	7/8"
DIM - E	3/8"

NOTES

1. TOP DISCHARGE AREA SHOULD BE UNRESTRICTED FOR AT LEAST 60" ABOVE UNIT. UNIT SHOULD BE PLACED SO ROOF RUN-OFF WATER DOES NOT POUR DIRECTLY ON UNIT, AND SHOULD BE AT LEAST 12" FROM WALL AND ALL SURROUNDING SHRUBBERY ON TWO SIDES. OTHER TWO SIDES UNRESTRICTED.
2. ELECTRICAL AND REFRIGERANT COMPONENT CLEARANCES PER PREVAILING CODES.

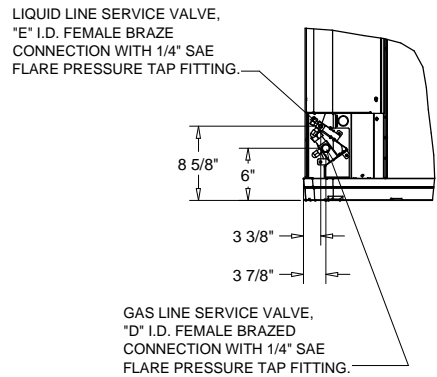
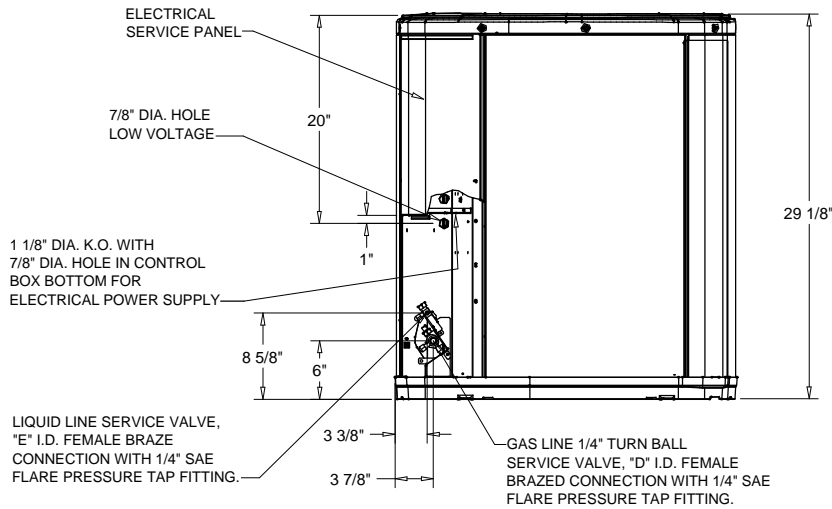

Unit Dimensions - Split System Air Conditioning Units (Small)

Item: B3 Qty: 1 Tag(s): Zone 7 Split

ELECTRICAL / GENERAL DATA

<p>GENERAL</p> <p>Model: 4TTA3048*</p> <p>Operating Voltage: 414-506</p> <p>Unit Primary Voltage: 460</p> <p>Unit Secondary Voltage: -</p> <p>Unit Hertz: 60</p> <p>Unit Phase: 3</p>	<p>POWER CONN.</p> <p>Minimum Circuit Ampacity: 9.0</p> <p>Maximum Circuit Breaker: 15.0</p> <p>Minimum Protection Rating: 15.0</p>	<p>COMPRESSOR</p> <p>Number: 1</p> <p>Phase: 3</p> <p>Rated Load Amps: 6.4</p> <p>Locked Rotor Amps: 46.0</p>
<p>OUTDOOR MOTOR</p> <p>Number: 1</p> <p>Horsepower: 0.20</p> <p>Motor Speed (RPM): 825</p> <p>Phase: 3</p> <p>Full Load Amps: 0.6</p> <p>Locked Rotor Amps: -</p>	<p>NOTES:</p> <p>1. Certified in accordance with the Unitary Air-Conditioner equipment certification program which is based on AHRI Standard 210/240.</p> <p>2. Calculated in accordance with N.E.C. Use only HACR circuit breakers or fuses.</p> <p>3. Standard line lengths - 60'. Standard lift - 60' Suction and Liquid line. For Greater lengths and lifts refer to refrigerant piping software Pub# 32-3312-0</p> <p>4. * = 15, 20, 25, 30, 40 and 50 foot lineset available.</p>	
<p>REFRIGERANT</p> <p>Type: R-410</p> <p>Charge: 6.4 lb</p> <p>Line Size O.D. Gas: 7/8"</p> <p>Line Size O.D. LIQ: 3/8"</p>		

WEIGHT	
NET	196"
SHIPPING	228.0 lb

- NOTES:**
- C1. TOP DISCHARGE SHOULD BE UNRESTRICTED FOR AT LEAST 60" ABOVE UNIT
 - C2. PLACE UNIT FROM WALL
 - C3. PLACE SHRUBBERY AT LEAST 12" FROM UNIT ON TWO SIDES, OTHER SIDES UNRESTRICTED
 - C4. PLACE UNIT SO ROOF RUN-OFF DOES NOT FALL DIRECTLY ON UNIT

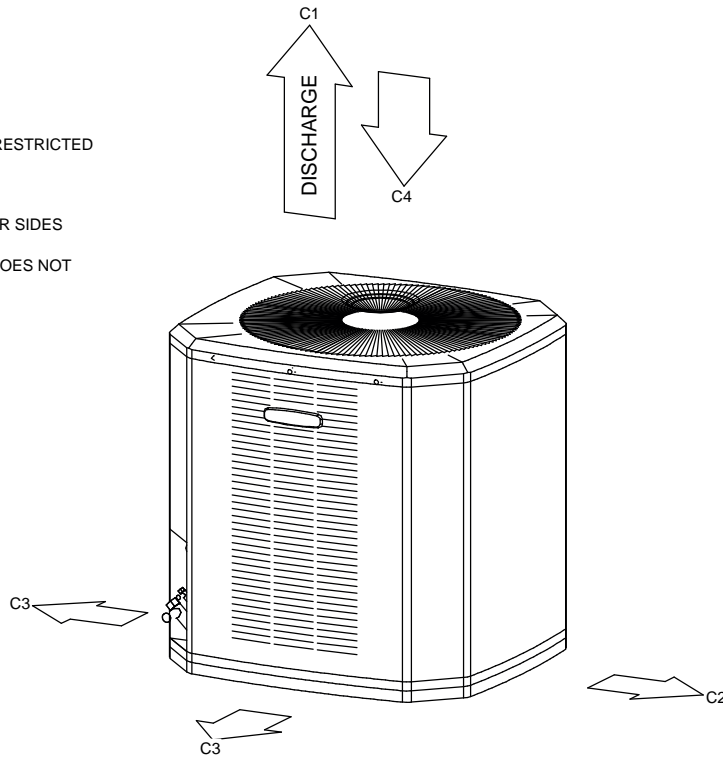

WEIGHT AND CLEARANCE

Unit Dimensions - Split System Air Conditioning Units (Small)

Item: B3, B4 Qty: 3 Tag(s): Zone 7 Split, Zone 4 Split, Zone 9 Split

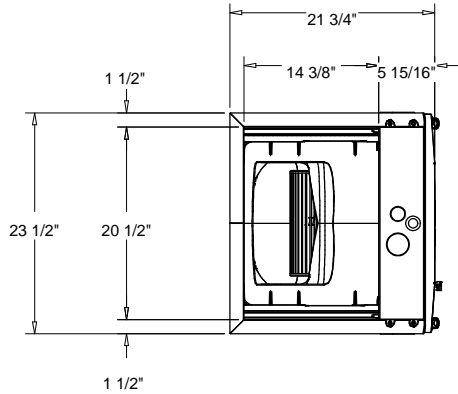

- NOTES:
1. BADGE ROTATION WILL KEEP BRAND IN CORRECT POSITION.
 2. NO INTERNAL MODIFICATIONS REQUIRED FOR ANY POSITION.
 3. VERIFY WEIGHT, CONNECTION, AND ALL DIMENSION WITH INSTALLER DOCUMENTS BEFORE INSTALLATION
 4. GAM5 AIR HANDLERS ARE ALL TWO PIECE CABINETS.
 5. SEE WEIGHT AND RIGGING PAGE FOR CONDENSATE DRAIN CONFIGURATION

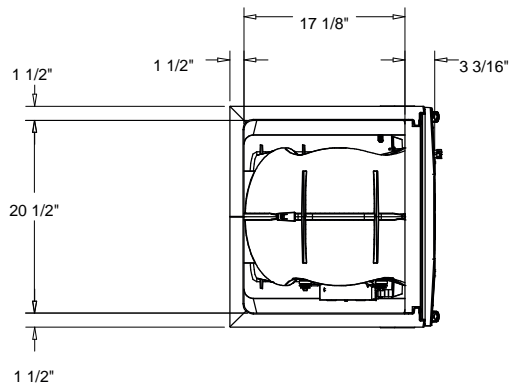
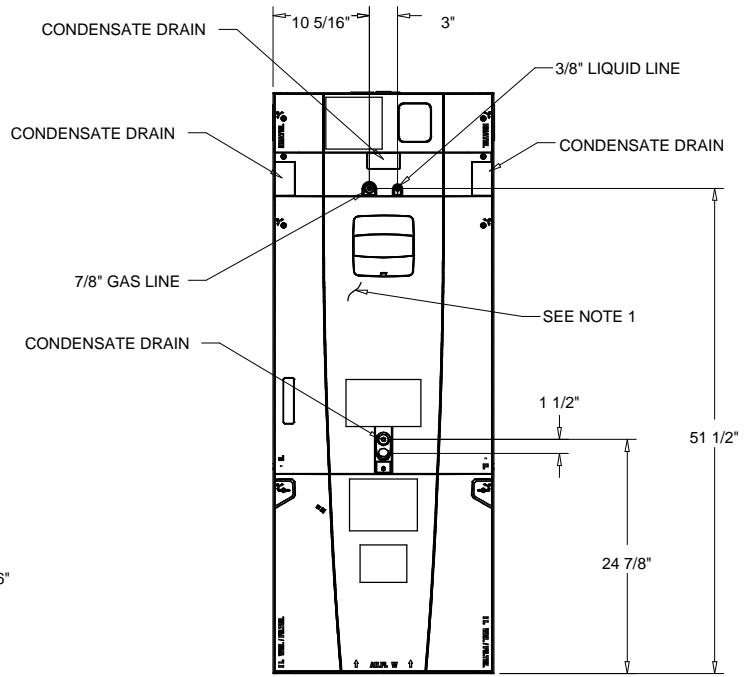
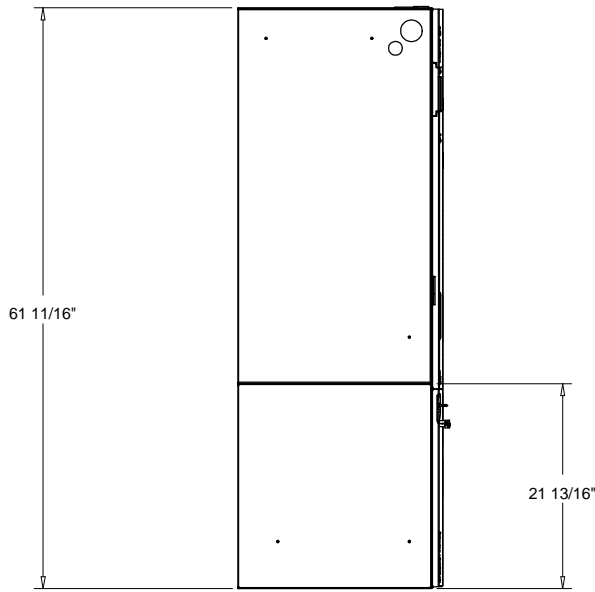

GAM5A0A48 & 60 AIR HANDLER- COOLING

UNIT DIMENSION DRAWING

Unit Dimensions - Split System Air Conditioning Units (Small)

Item: B3 Qty: 1 Tag(s): Zone 7 Split

ELECTRICAL / GENERAL DATA

<p>GENERAL ⁽¹⁾⁽²⁾⁽⁴⁾</p> <p>Model: GAM5A0C48M41SA</p> <p>Unit Primary Voltage: 208 Unit Secondary Voltage: 230 Unit Hertz: 60 Unit Phase: 1</p>	<p>INDOOR MOTOR ⁽¹⁾</p> <p>Number: 1 Horsepower: 0.75 Motor Speed (RPM): 1050 Phase: 1 Full Load Amps: 6.0 Locked Rotor Amps:</p>	<p>FILTERS ⁽³⁾</p> <p>Type: Throwaway Furnished: No Number: 1 Recommended: 22"x20"x1"</p>
<p>STANDARD ⁽⁵⁾</p> <p>230 Volt / 208 Volt</p> <p>Minimum Circuit Ampacity: 8.0/8.0 Maximum Overload Protection: 15.0/15.0</p>	<p>REFRIGERANT</p> <p>Type: R410 REF. Line Connections: Brazed Coupling or Conn. Size - Gas: 7/8" Coupling or Conn. Size - Liq.: 3/8"</p>	<p>Weights</p> <p>Net: 166.0 lb Shipping: 176.0 lb</p>
<p>ELECTRIC HEAT</p> <p>230 Volt / 208 Volt</p> <p>Capacity Circuit #1: 9.60kW/7.20kW Capacity Circuit #2: N/A Capacity Circuit #3: N/A</p> <p># of Circuit: 1 Phase: 1</p> <p>Heater Amps Per Circuit Circuit #1: 40.0/34.60 Heater Amps Per Circuit Circuit #2: N/A Heater Amps Per Circuit Circuit #3: N/A</p> <p>Minimum Circuit Ampacity Circuit #1: 58.0/51.0 Minimum Circuit Ampacity Circuit #2: N/A Minimum Circuit Ampacity Circuit #3: N/A</p> <p>Maximum Overload Protection Circuit #1: 60.0/60.0 Maximum Overload Protection Circuit #2: N/A Maximum Overload Protection Circuit #3: N/A</p>	<p>NOTES:</p> <ol style="list-style-type: none"> 1. These air handlers are a.r.i. certified with various split system air conditioners and heat pumps (ari standard 210/240). refer tothesplit system outdoor unit product data guides for performance data. 2. 3/4" male plastic pipe (ref.: astm 1785-76) 3. Minimum filter size for horizontal applications will be based on airflow selection and will be calculated as follows: low velocity filter: face area (sq. ft.) = cfm / 300 high velocity filter: face area (sq. ft.) = cfm / 500 4. For customer ease of filter maintenance, it is recommended that a properly sized, remote filter and grille be installed for horizontal applications. airflow should not exceed the face value of the filter being used 5. Standard mca and mop without electric heat. 	

Unit Dimensions - Split System Air Conditioning Units (Small)

Item: B3, B4 Qty: 3 Tag(s): Zone 7 Split, Zone 4 Split, Zone 9 Split

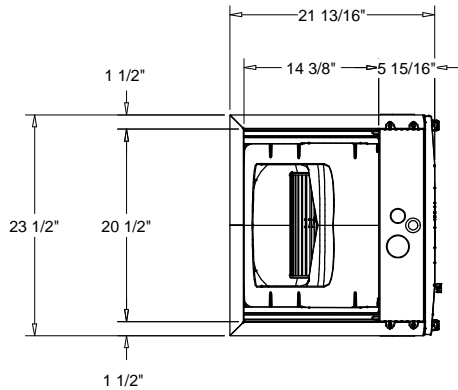

NOTES:

1. BADGE ROTATION WILL KEEP BRAND IN CORRECT POSITION.
2. NO INTERNAL MODIFICATIONS REQUIRED FOR ANY POSITION.
3. VERIFY WEIGHT, CONNECTION, AND ALL DIMENSION WITH INSTALLER DOCUMENTS BEFORE INSTALLATION
4. GAM5 AIR HANDLERS ARE ALL TWO PIECE CABINETS.
5. SEE WEIGHT AND RIGGING PAGE FOR CONDENSATE DRAIN CONFIGURATION

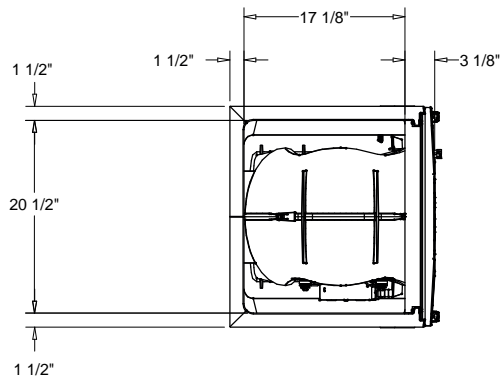
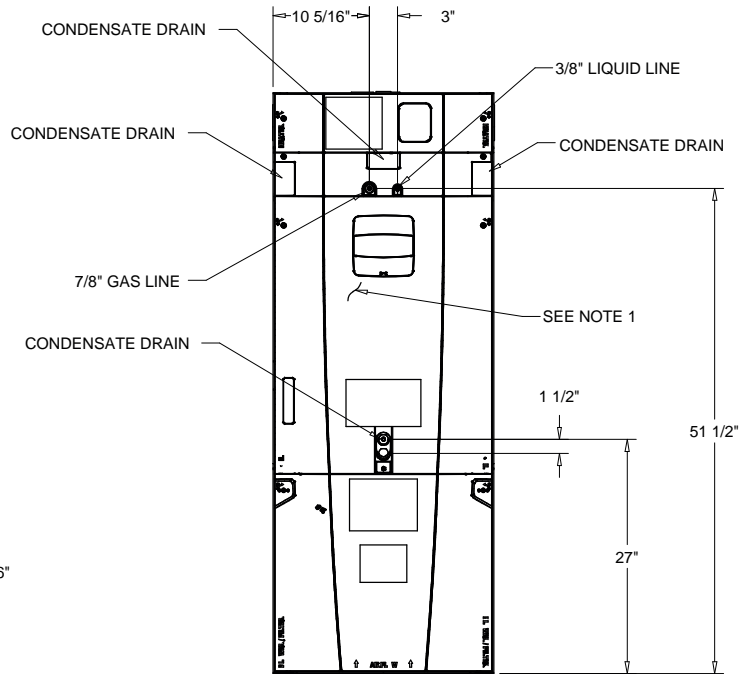
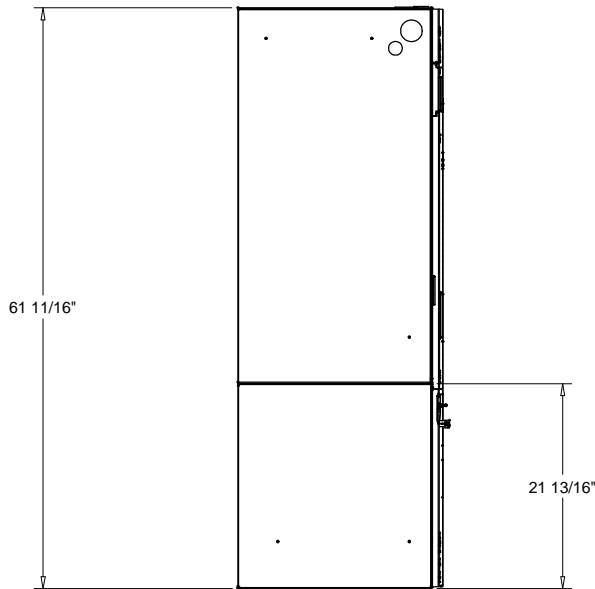

GAT2A0C60S51SA AIR HANDLER- COOLING

UNIT DIMENSION DRAWING

Unit Dimensions - Split System Air Conditioning Units (Small)

Item: B4 Qty: 2 Tag(s): Zone 4 Split, Zone 9 Split

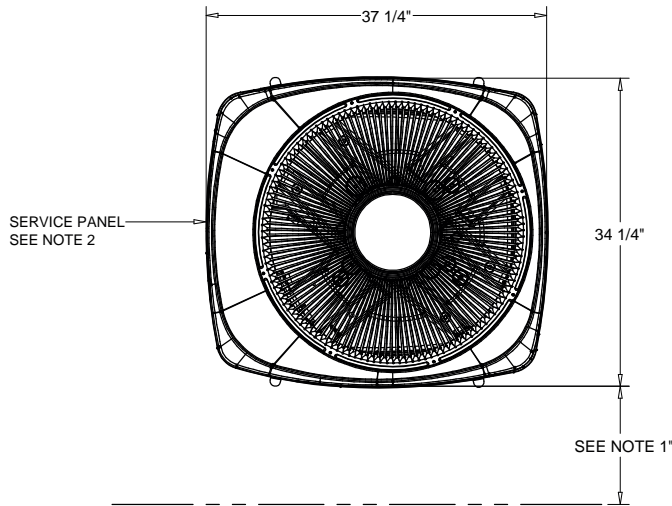

NOTES

1. TOP DISCHARGE AREA SHOULD BE UNRESTRICTED FOR AT LEAST 60" ABOVE UNIT. UNIT SHOULD BE PLACED SO ROOF RUN-OFF WATER DOES NOT POUR DIRECTLY ON UNIT, AND SHOULD BE AT LEAST 12" FROM WALL AND ALL SURROUNDING SHRUBBERY ON TWO SIDES. OTHER TWO SIDES UNRESTRICTED.
2. ELECTRICAL AND REFRIGERANT COMPONENT CLEARANCES PER PREVAILING CODES.

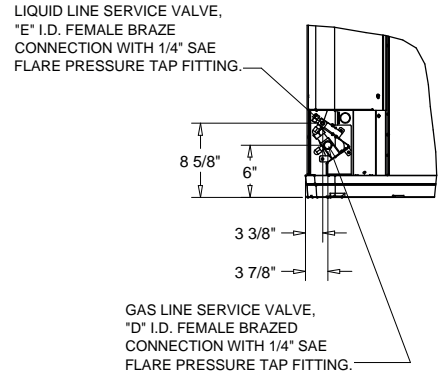
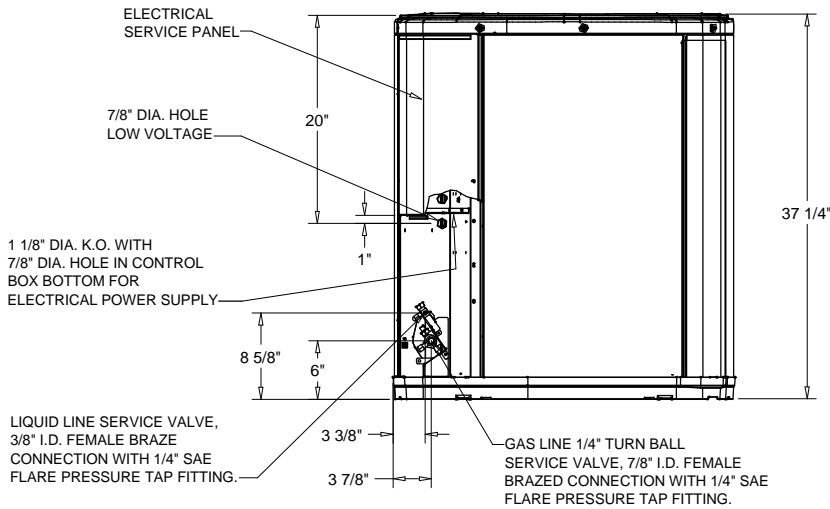

Unit Dimensions - Split System Air Conditioning Units (Small)

Item: B4 Qty: 2 Tag(s): Zone 4 Split, Zone 9 Split

ELECTRICAL / GENERAL DATA

<p>GENERAL</p> <p>Model: 4TTA3060*</p> <p>Operating Voltage: 414-506</p> <p>Unit Primary Voltage: 460</p> <p>Unit Secondary Voltage: -</p> <p>Unit Hertz: 60</p> <p>Unit Phase: 3</p>	<p>POWER CONN.</p> <p>Minimum Circuit Ampacity: 12.0</p> <p>Maximum Circuit Breaker: 20.0</p> <p>Minimum Protection Rating: 20.0</p>	<p>COMPRESSOR</p> <p>Number: 1</p> <p>Phase: 3</p> <p>Rated Load Amps: 9.0</p> <p>Locked Rotor Amps: 52.0</p>
<p>OUTDOOR MOTOR</p> <p>Number: 1</p> <p>Horsepower: 0.6</p> <p>Motor Speed (RPM): 825</p> <p>Phase: 3</p> <p>Full Load Amps: 0.20</p> <p>Locked Rotor Amps: -</p>	<p>NOTES:</p> <p>1. Certified in accordance with the Unitary Air-Conditioner equipment certification program which is based on AHRI Standard 210/240.</p> <p>2. Calculated in accordance with N.E.C. Use only HACR circuit breakers or fuses.</p> <p>3. Standard line lengths - 60'. Standard lift - 60' Suction and Liquid line. For Greater lengths and lifts refer to refrigerant piping software Pub# 32-3312-0</p> <p>4. * = 15, 20, 25, 30, 40 and 50 foot lineset available.</p>	
<p>REFRIGERANT</p> <p>Type: R-410</p> <p>Charge: 8.0 lb</p> <p>Line Size O.D. Gas: 7/8"</p> <p>Line Size O.D. LIQ: 3/8"</p>		

WEIGHT	
NET	226.0 lb
SHIPPING	261.0 lb

- NOTES:**
- C1. TOP DISCHARGE SHOULD BE UNRESTRICTED FOR AT LEAST 60" ABOVE UNIT
 - C2. PLACE UNIT FROM WALL
 - C3. PLACE SHRUBBERY AT LEAST 12" FROM UNIT ON TWO SIDES, OTHER SIDES UNRESTRICTED
 - C4. PLACE UNIT SO ROOF RUN-OFF DOES NOT FALL DIRECTLY ON UNIT

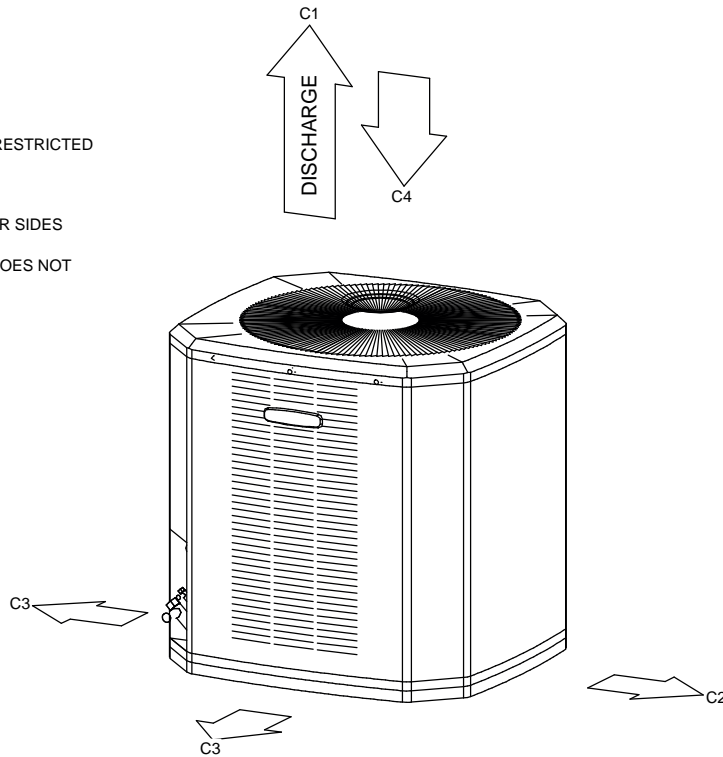

WEIGHT AND CLEARANCE

Unit Dimensions - Split System Air Conditioning Units (Small)

Item: B4 Qty: 2 Tag(s): Zone 4 Split, Zone 9 Split

ELECTRICAL / GENERAL DATA

<p>GENERAL ⁽¹⁾⁽²⁾⁽⁴⁾</p> <p>Model: GAM5A0C60M51SA</p> <p>Unit Primary Voltage: 208 Unit Secondary Voltage: 230 Unit Hertz: 60 Unit Phase: 1</p>	<p>INDOOR MOTOR ⁽¹⁾</p> <p>Number: 1 Horsepower: 1.0 Motor Speed (RPM): 1050 Phase: 1 Full Load Amps: 7.6 Locked Rotor Amps:</p>	<p>FILTERS ⁽³⁾</p> <p>Type: Throwaway Furnished: No Number: 1 Recommended: 22"x20"x1"</p>
<p>STANDARD ⁽⁵⁾</p> <p>230 Volt / 208 Volt</p> <p>Minimum Circuit Ampacity: 10.0/10.0 Maximum Overload Protection: 15.0/15.0</p>	<p>REFRIGERANT</p> <p>Type: R410 REF. Line Connections: Brazed Coupling or Conn. Size - Gas: 7/8" Coupling or Conn. Size - Liq.: 3/8"</p>	<p>Weights</p> <p>Net: 170.0 lb Shipping: 180.0 lb</p>
<p>ELECTRIC HEAT</p> <p>230 Volt / 208 Volt</p> <p>Capacity Circuit #1: Capacity Circuit #2: Capacity Circuit #3:</p> <p># of Circuit: Phase:</p> <p>Heater Amps Per Circuit Circuit #1: Heater Amps Per Circuit Circuit #2: Heater Amps Per Circuit Circuit #3:</p> <p>Minimum Circuit Ampacity Circuit #1: Minimum Circuit Ampacity Circuit #2: Minimum Circuit Ampacity Circuit #3:</p> <p>Maximum Overload Protection Circuit #1: Maximum Overload Protection Circuit #2: Maximum Overload Protection Circuit #3:</p>	<p>NOTES:</p> <ol style="list-style-type: none"> 1. These air handlers are a.r.i. certified with various split system air conditioners and heat pumps (ari standard 210/240). refer tothesplit system outdoor unit product data guides for performance data. 2. 3/4" male plastic pipe (ref.: astm 1785-76) 3. Minimum filter size for horizontal applications will be based on airflow selection and will be calculated as follows: low velocity filter: face area (sq. ft.) = cfm / 300 high velocity filter: face area (sq. ft.) = cfm / 500 4. For customer ease of filter maintenance, it is recommended that a properly sized, remote filter and grille be installed for horizontal applications. airflow should not exceed the face value of the filter being used 5. Standard mca and mop without electric heat. 	

Weight, Clearance & Rigging Diagram - Split System Air Conditioning Units (Small)

Item: B1 - B4 Qty: 5 Tag(s): Zone 1 Split, Zone 6 Split, Zone 7 Split, Zone 4 Split, Zone 9 Split

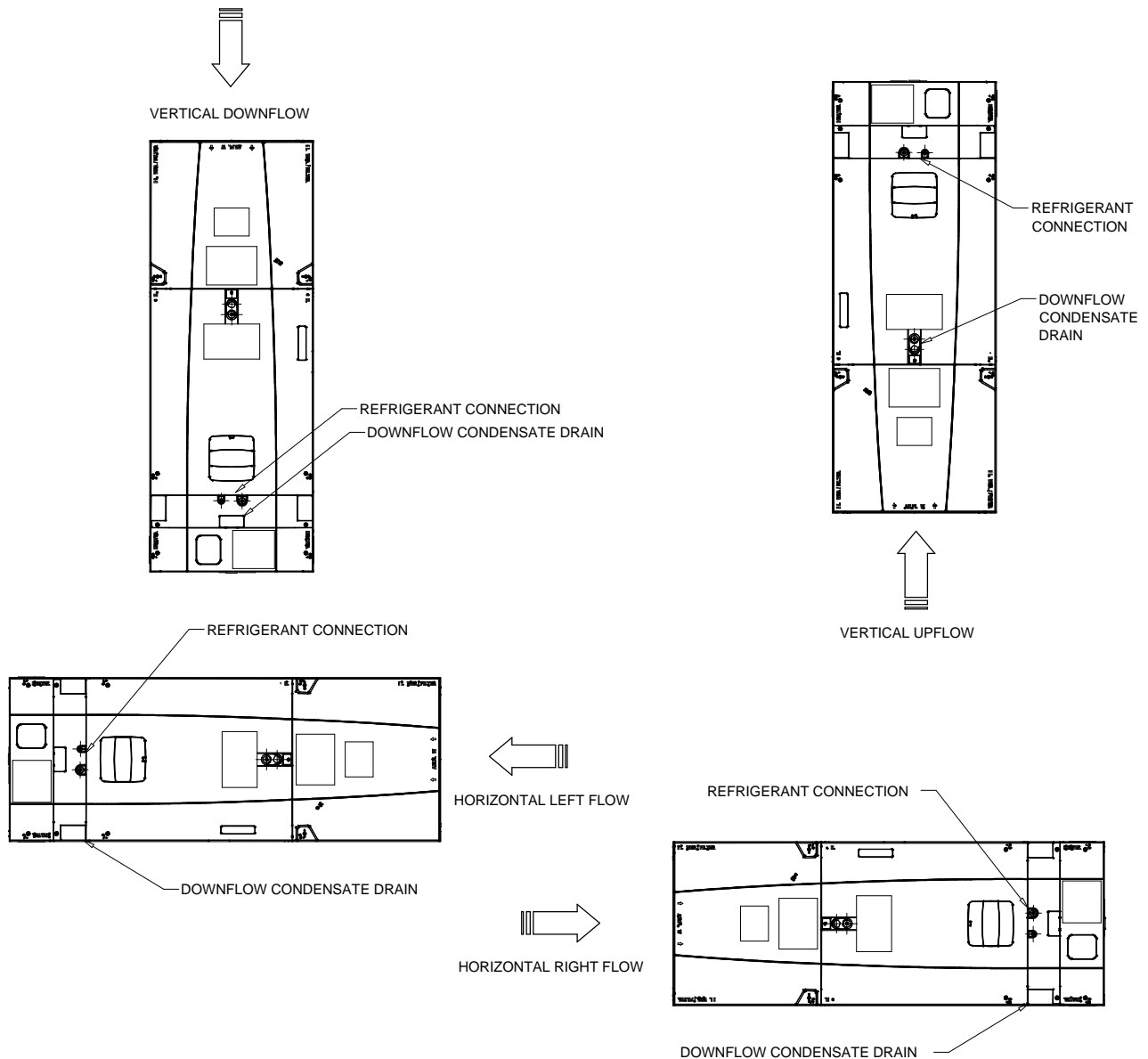

NOTES

1. NO INTERNAL MODIFICATIONS REQUIRED FOR ANY POSITION.
2. BADGE ROTATION WILL BRAND IN CORRECT POSITION.

MINIMUM UNIT CLEARANCE TABLE		
	TO COMBUSTIBLE MATERIALS (REQUIRED)	SERVICE CLEARANCE (RECOMMENDED)
SIDE	0	2"
FRONT	0	21"
BACK	0	0
INLET DUCT	0	0
OUTLET DUCT	0	0

CLEARANCE NOTES:
 * 1" FOR THE FIRST 3 FT. OF OUTLET DUCT
 WHEN ELECTRIC HEATERS ARE INSTALLED EXCEPT
 MODELS BAYHTR1405, 1408, AND 1410 ARE APPROVED FOR
 0" PLENUM AND DUCT CLEARANCE IN THE UPFLOW
 CONFIGURATION ONLY ON TWE-P MODELS.

Tag Data - Packaged Air Handling Units (Qty: 5)

Item	Tag(s)	Qty	Description	Model Number
C1	Zone 5 AHU, Zone 10 AHU	2	Packaged Climate Changer (LPCA) (LPC)	LPCAA10F
C2	Zone 2 AHU, Zone 3 AHU	2	Packaged Climate Changer (LPCA) (LPC)	LPCAA12F
C3	Zone 8 AHU	1	Packaged Climate Changer (LPCA) (LPC)	LPCAA17F

Product Data - Packaged Air Handling Units

All Units

Packaged Climate Changer
 Horizontal with Front Top Discharge
 460/60/3
 1" Matt Faced Insulation Fan Section with 1" Solid Double Wall Wet Section
 Polymer Drainpan, RH Coil & Drain Conn. / RH Motor & Drive Location
 4 Row DX Coil with 9 Fins per Inch, 3/16" Dist.
 Control Interface
 Intertwined Circuit With 2 Stage DX
 Constant Volume with Variable Pitch Sheaves
 Mixing section with flat unit MERV 8
 Condensate Overflow Switch
 Discharge Air Sensor and Normally Closed Factory Mounted Mixing Box Actuator

Item: C1 Qty: 2 Tag(s): Zone 5 AHU, Zone 10 AHU

Unit Size 10 Square Feet of Coil
 3 Horsepower (2.238 kW) Motor
 950 rpm Fixed / 900 - 1000 Variable

Item: C2 Qty: 2 Tag(s): Zone 2 AHU, Zone 3 AHU

Unit Size 12 Square Feet of Coil
 3 Horsepower (2.238 kW) Motor
 750 rpm Fixed / 700 - 800 Variable

Item: C3 Qty: 1 Tag(s): Zone 8 AHU

Unit Size 17 Square Feet of Coil
 5 Premium Horsepower (3.730 KW) Motor
 650 rpm Fixed / 600 - 700 Variable

Performance Data - Packaged Air Handling Units

Tags	Zone 5 AHU, Zone 10 AHU	Zone 2 AHU, Zone 3 AHU	Zone 8 AHU
Design airflow (cfm)	5000	6000	8000
Total cooling capacity (MBh)	143.41	178.70	263.13
Sensible capacity (MBh)	111.99	137.42	193.14
Main coil type	DX - R410a	DX - R410a	DX - R410a
Cooling EDB (F)	80.00	80.00	80.00
Cooling EWB (F)	67.00	67.00	67.00
Cooling LDB (F)	59.63	59.17	58.03
Cooling LWB (F)	58.03	57.65	56.57
Cooling face velocity (ft/min)	513	484	474
Preheat coil type	None	None	None
Reheat coil type	None	None	None
Elevation (ft)	0.00	0.00	0.00
ESP (in H2O)	0.500	0.500	0.500
TSP (in H2O)	1.551	1.381	1.309
Actual motor power reqd (hp)	2.578	2.818	3.459
Fan speed (rpm)	912	730	646
Coolling APD (in H2O)	0.547	0.505	0.496
Filter/Mixing section APD (in H2O)	0.530	0.399	0.335
Face & bypass section APD (in H2O)	0.000	0.000	0.000
Outlet velocity (ft/min)	2375	2360	2298

Tags	Zone 5 AHU, Zone 10 AHU	Zone 2 AHU, Zone 3 AHU	Zone 8 AHU
Full load amps (A)	4.00	4.00	6.60
Max fuse size (A)	15.00	15.00	15.00
Min circuit ampacity (A)	5.00	5.00	8.25
Run acoustics?	No	No	No
Unit length (in)	77.500	83.250	91.250
Unit width (in)	60.220	68.220	76.220
Unit height (in)	34.500	42.000	52.000
Installed weight (lb)	623.9	850.3	1129.9
Rigging weight (lb)	623.9	850.3	1129.9

Mechanical Specifications - Packaged Air Handling Units**Item: C1 - C3 Qty: 5 Tag(s): Zone 5 AHU, Zone 10 AHU, Zone 2 AHU, Zone 3 AHU, Zone 8 AHU****General**

The Packaged Climate Changers are provided with forward curved, centrifugal fans with one fan for each unit size. All units ship from the factory with UL/CUL listing and the performance is certified by both AHRI 410 and AHRI 430. The units are also constructed in compliance with NFPA 90A.

Casing

The casing structural components are constructed of heavy gage galvanized steel. Coil access panels, fan access panels, filter access panels and drainpans are provided with solid double-wall, foamed in place insulation. All other sections are single wall construction. Coil access panels are located on both sides of the unit to allow easy removal of the coils. Fan access panels provide generous access to the fan, motor and drive from both sides of the unit.

Matt Faced Insulation

Single wall sections are provided with Tuf-skin one-inch, 1-1/2 pounds per cubic foot matt faced insulation that is designed to withstand high velocities and meet NFPA 90A and UL 181.

Coil #1 Dual Circuit, Intertwined Direct Expansion Coil

Direct expansion coils are constructed with galvanized steel casings and highly efficient Trane Wavy 3B aluminum fins, which are mechanically bonded to 1/2" seamless copper tubing. DX coils are available with 4 or 6 rows and either 9, 12 or 14 fins per inch and 3/16" or 1/4" distributors. These coils have a dual circuit design with multiple distributors and an intertwined arrangement. All DX coils are factory tested with a 450 psi air under water. All DX coils have distributor tubes brazed into place with tubing extended to the exterior of the unit casing for field connection. Coils ship sealed with a dry air charge to minimize moisture contamination.

Fan

The fans are forward curved, centrifugal blower type. The fan shaft is supported by permanently lubricated bearings with 200,000 hour, L50 design life. All fans are dynamically balanced. All air handlers have a single fan.

Drives

The units have variable pitch sheaves.

Polymer Drain Pan for Unit Sizes 8 through 30

The drainpans are double wall foamed in place assemblies made of a non-corrosive polymer material sloped in two directions. The drainpan is fully drainable. The coils mount above the drainpan, not in the drainpan, thus allowing the drainpan to be fully inspected and cleaned.

The drain connection is unthreaded 1" schedule 40 polymer for solvent bonding.

Unit Filters

The units are equipped with 2" flat pleated media filters with a rated average dust spot efficiency of no less than 35 to 40 percent when tested in accordance with ASHRAE 52.1 atmospheric dust spot method, and MERV 8 rating based on ASHRAE Standard 52.2.

Integral HP 3 Phase Motors

Motors are open drip proof with permanently sealed ball bearings. Motors have a minimum 1.15 service factor and require external current overload protection. Motors are in compliance with EPACT where applicable.

Mixing Section

The mixing sections are constructed of heavy gage galvanized steel with two low leak parallel blade dampers with edge and jam seals. A 1/2" drive shaft is provided on each damper that can be used with an actuator.

Mixing sections also include access panels on both sides of the section to provide access to the internal components.

Control Interface

The Control Interface includes a disconnect switch, motor current overload protection (if applicable), fused line voltage to 24 volt transformer, three pole fan contactor and customer terminal strip.

Condensate Overflow Switch

The units are provided with condensate overflow switches. These switch are normally closed devices the will open should the drain not function and an excessive amount of water accumulate in the drainpan.

Discharge Air Sensor

The units are provided with discharge a Sensors. These sensors are thermistor type sensors with a resistance of 10,000 OHMS at 25C (+/-1C).

Normally Closed Damper Actuator

The units are provided with normally closed damper actuators. The damper actuator requires an analog signal of 2 to 10 volt DC to operate. The normal position refers to the damper at the back of the mixing section.

Integral HP 3 Phase Premium Efficiency Motors

Motors are open drip proof with permanently sealed ball bearings. Motors have a minimum 1.15 service factor and require external current overload protection. Motors are in compliance with EPACT where applicable. Motors 5 hp and larger are NEMA premium efficient.

Unit Dimensions - Packaged Air Handling Units

Item: C1 Qty: 2 Tag(s): Zone 5 AHU, Zone 10 AHU

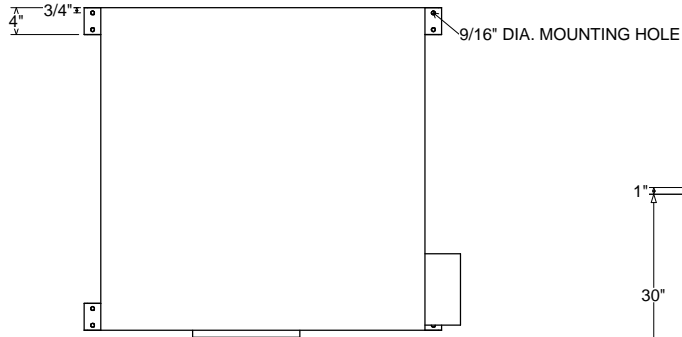

TOP

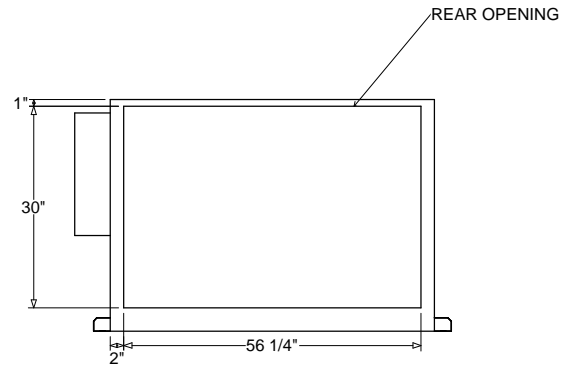

BACK

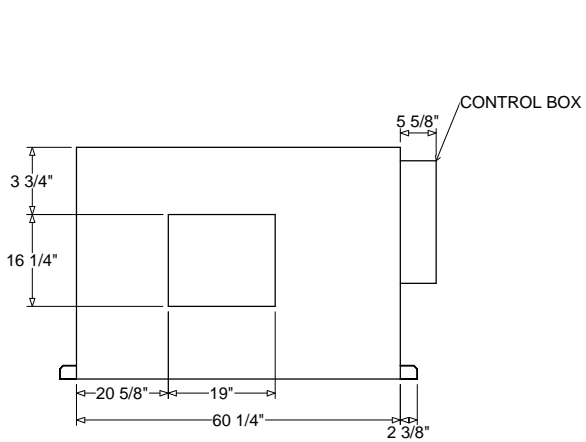

FRONT

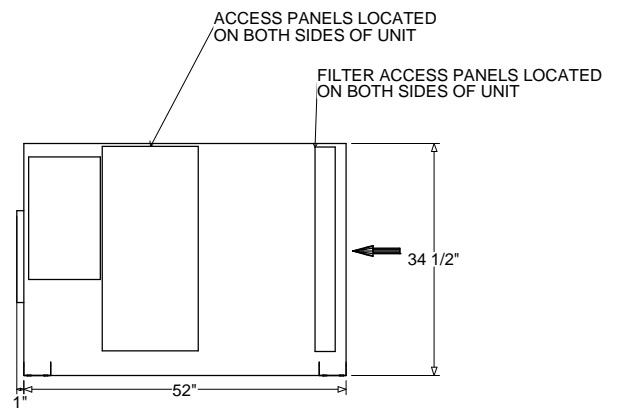

RIGHT

Unit Dimensions - Packaged Air Handling Units

Item: C1 Qty: 2 Tag(s): Zone 5 AHU, Zone 10 AHU

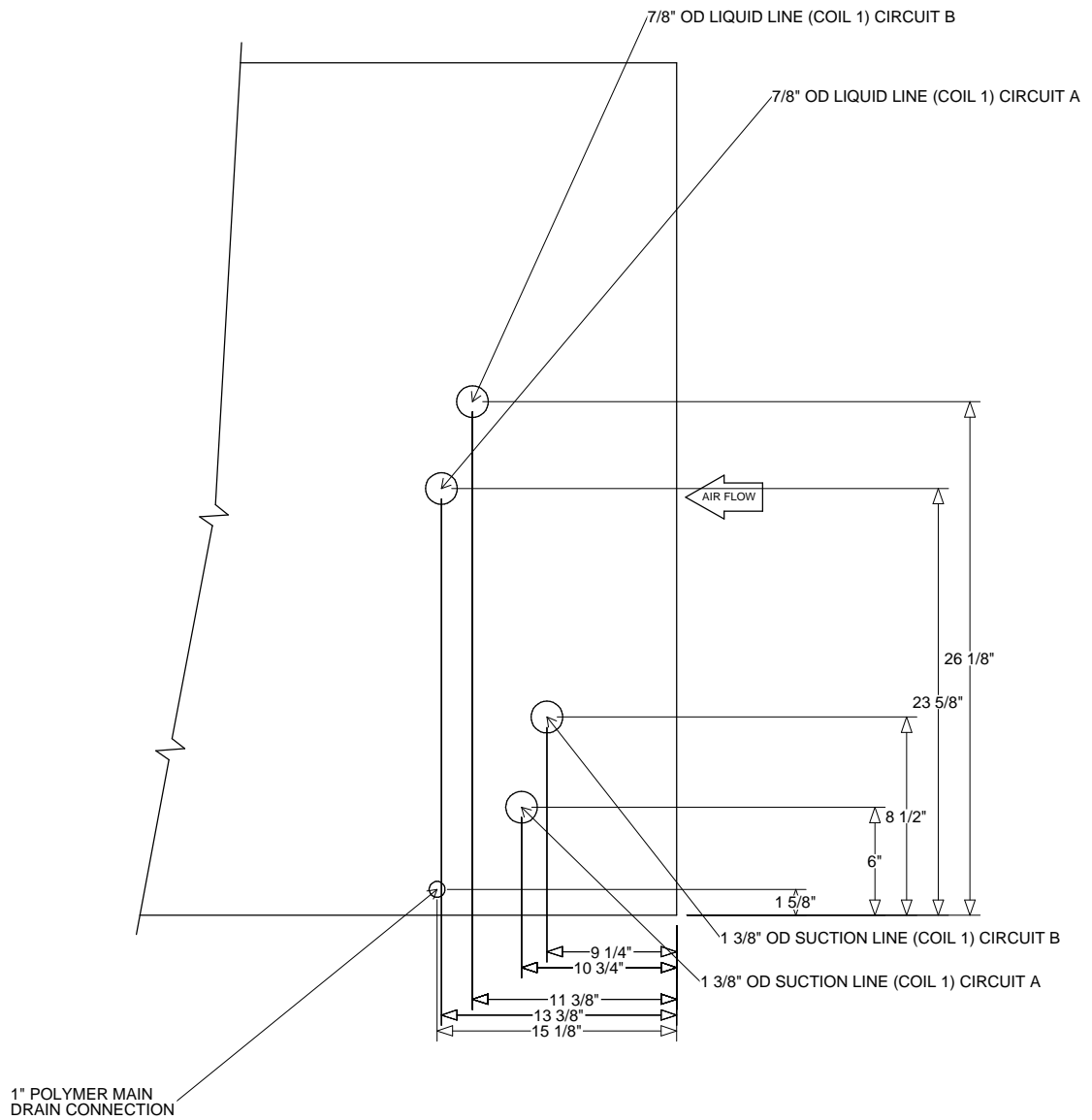

NOTES:

1. STUB OUT DEPTH IS 2.38" [60mm].
2. STUB OUT LOCATIONS ARE DIMENSIONED FROM THE BOTTOM REAR CORNER OF UNIT.
3. DIMENSIONS AND NOTES ARE CORRECT.
THE PICTORIAL HEADER LOCATIONS RELATIVE TO EACH OTHER MAY NOT BE ACCURATE.
4. THERMAL EXPANSION VALVE IS TO BE FIELD SUPPLIED.

Unit Dimensions - Packaged Air Handling Units
Item: C1 Qty: 2 Tag(s): Zone 5 AHU, Zone 10 AHU

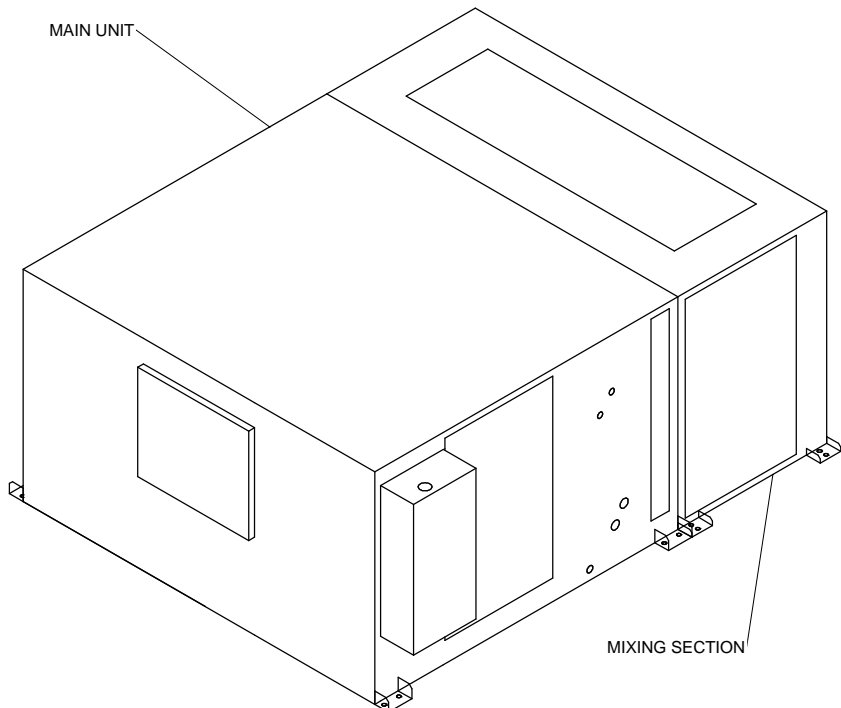

Unit Dimensions - Packaged Air Handling Units
Item: C2 Qty: 2 Tag(s): Zone 2 AHU, Zone 3 AHU

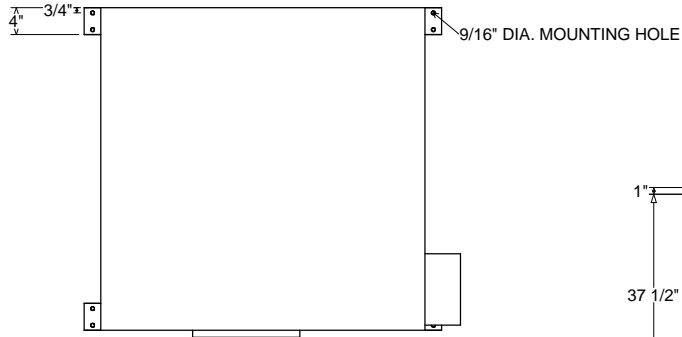

TOP

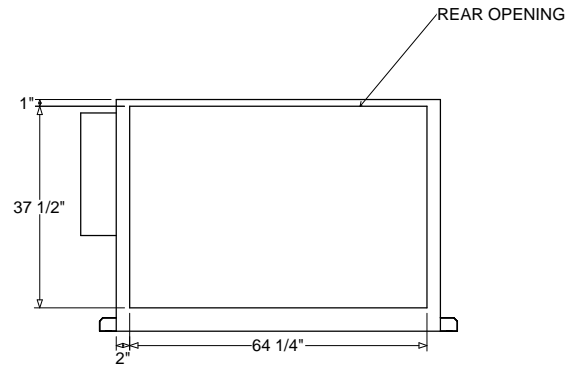

BACK

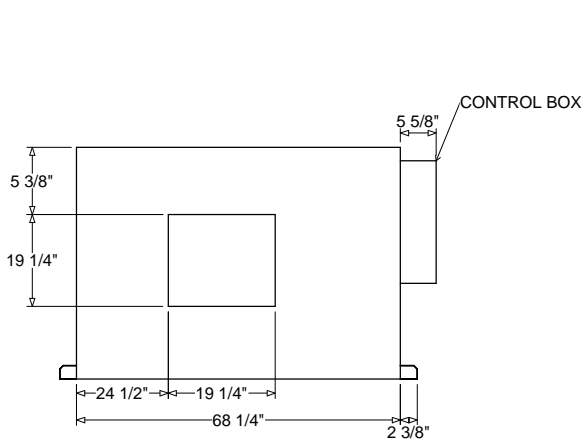

FRONT

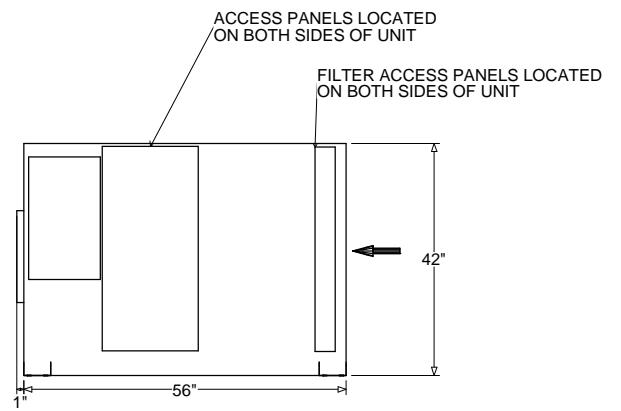

RIGHT

Unit Dimensions - Packaged Air Handling Units
Item: C2 Qty: 2 Tag(s): Zone 2 AHU, Zone 3 AHU

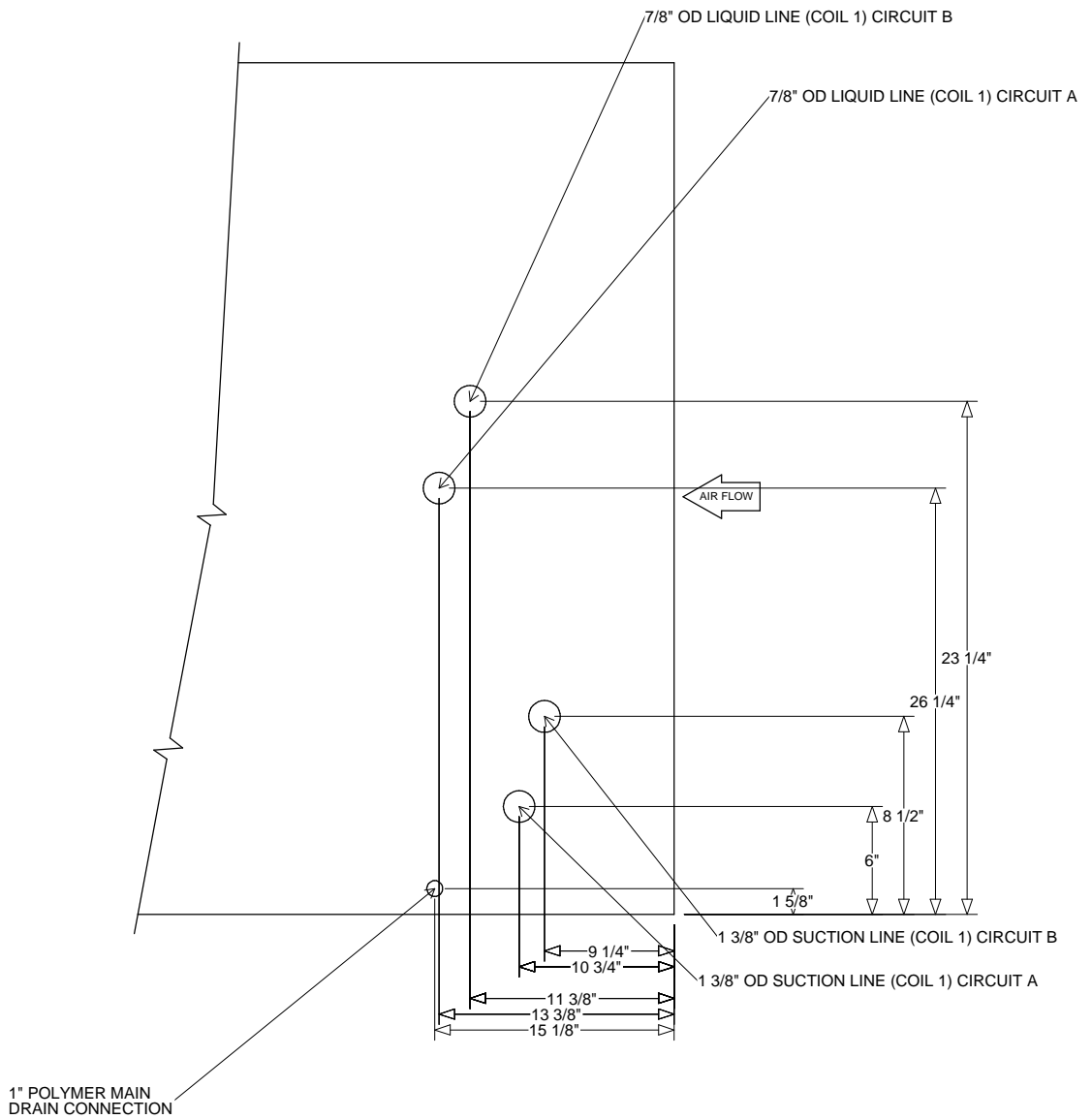

- NOTES:
1. STUB OUT DEPTH IS 2.38" [60mm].
 2. STUB OUT LOCATIONS ARE DIMENSIONED FROM THE BOTTOM REAR CORNER OF UNIT.
 3. DIMENSIONS AND NOTES ARE CORRECT.
 THE PICTORIAL HEADER LOCATIONS RELATIVE TO EACH OTHER MAY NOT BE ACCURATE.
 4. THERMAL EXPANSION VALVE IS TO BE FIELD SUPPLIED.

Unit Dimensions - Packaged Air Handling Units
Item: C2 Qty: 2 Tag(s): Zone 2 AHU, Zone 3 AHU

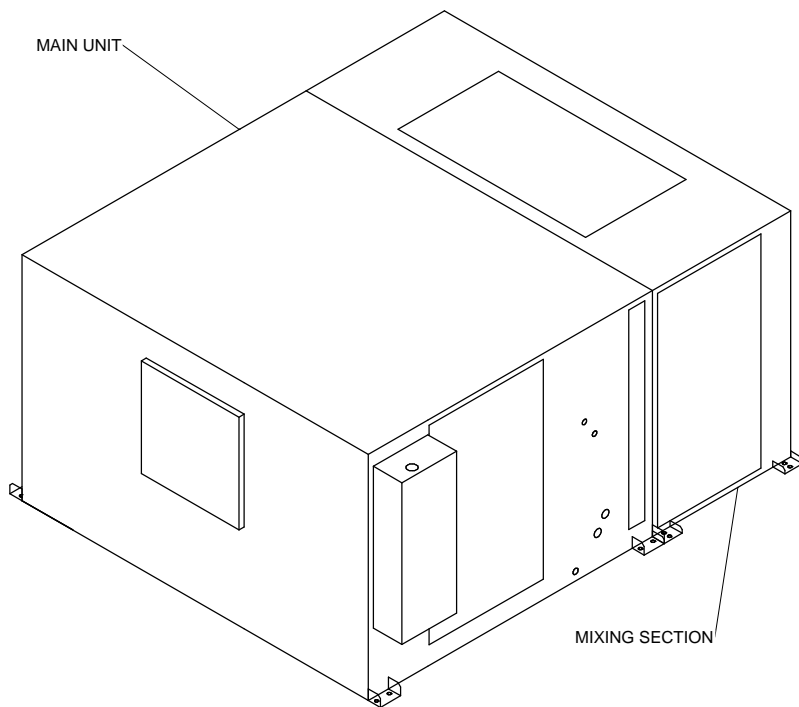

Unit Dimensions - Packaged Air Handling Units

Item: C3 Qty: 1 Tag(s): Zone 8 AHU

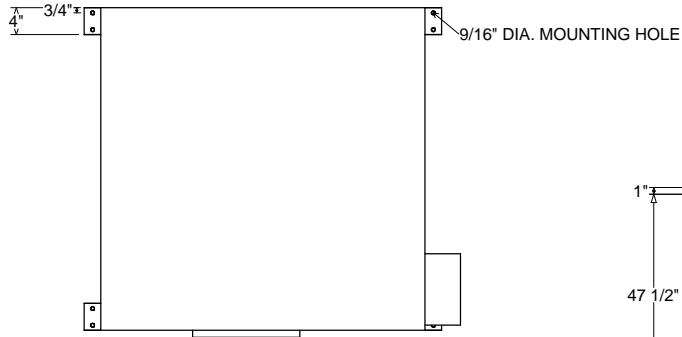

TOP

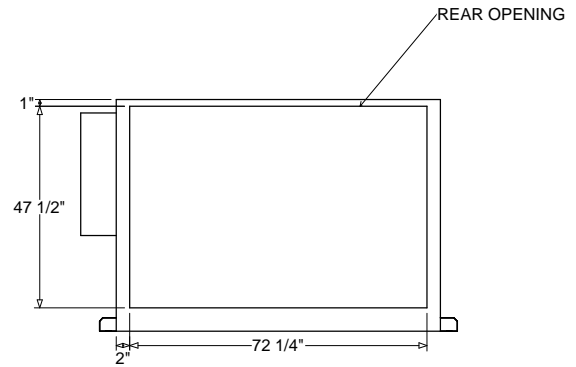

BACK

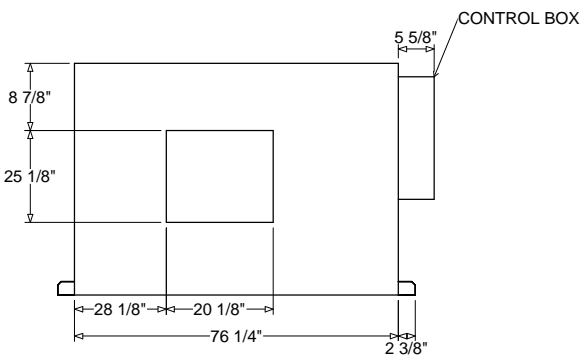

FRONT

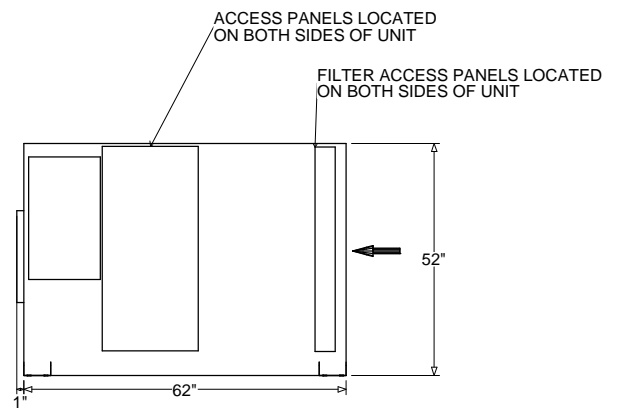

RIGHT

Unit Dimensions - Packaged Air Handling Units

Item: C3 Qty: 1 Tag(s): Zone 8 AHU

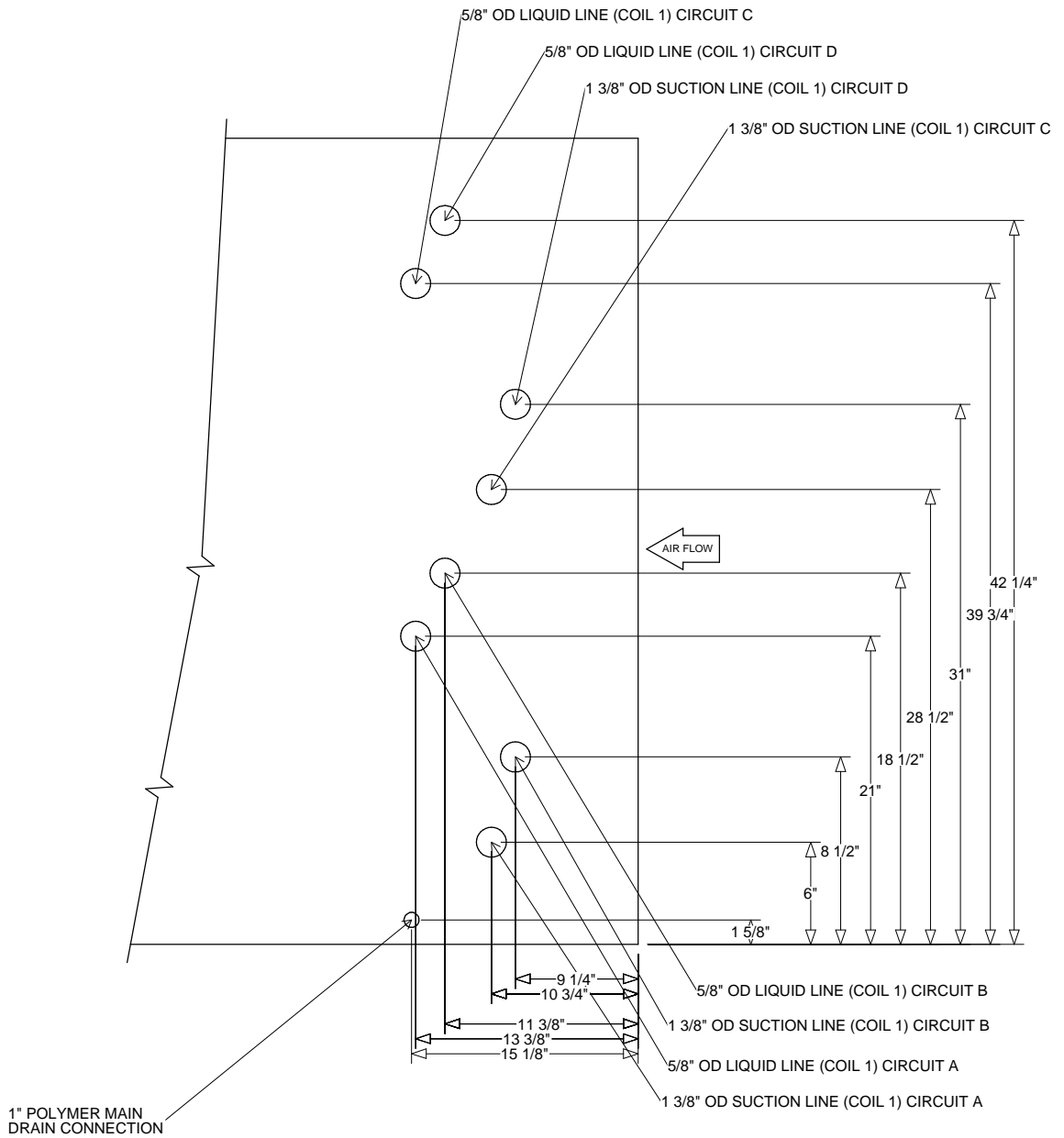

- NOTES:
1. STUB OUT DEPTH IS 2.38" [60mm].
 2. STUB OUT LOCATIONS ARE DIMENSIONED FROM THE BOTTOM REAR CORNER OF UNIT.
 3. DIMENSIONS AND NOTES ARE CORRECT.
THE PICTORIAL HEADER LOCATIONS RELATIVE TO EACH OTHER MAY NOT BE ACCURATE.
 4. THERMAL EXPANSION VALVE IS TO BE FIELD SUPPLIED.

Unit Dimensions - Packaged Air Handling Units

Item: C3 Qty: 1 Tag(s): Zone 8 AHU

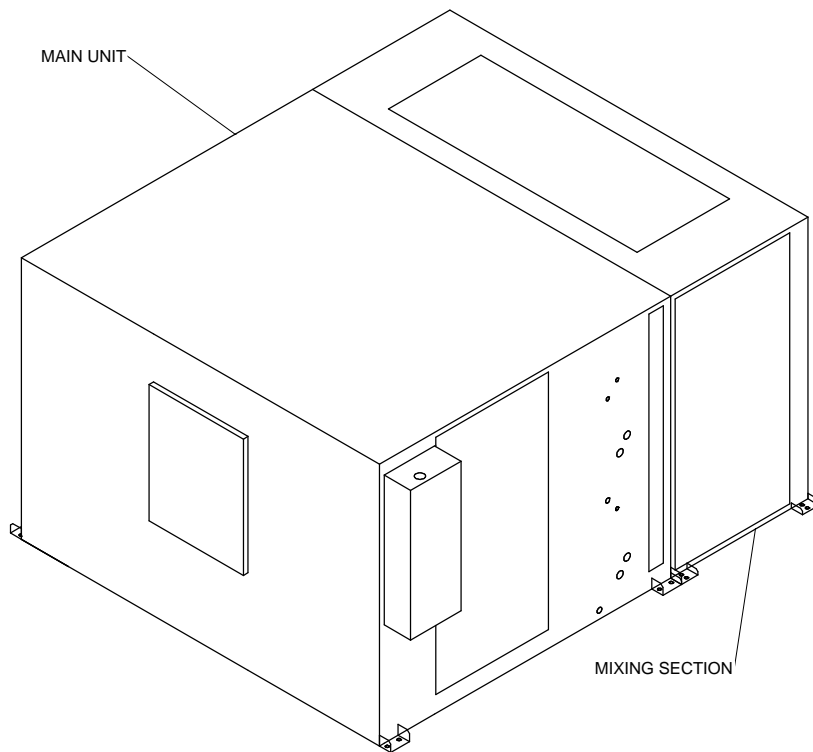

Fan Curve - Packaged Air Handling Units

Item: C1 Qty: 2 Tag(s): Zone 5 AHU, Zone 10 AHU

SIZE 10 HORIZONTAL/ FRONT TOP

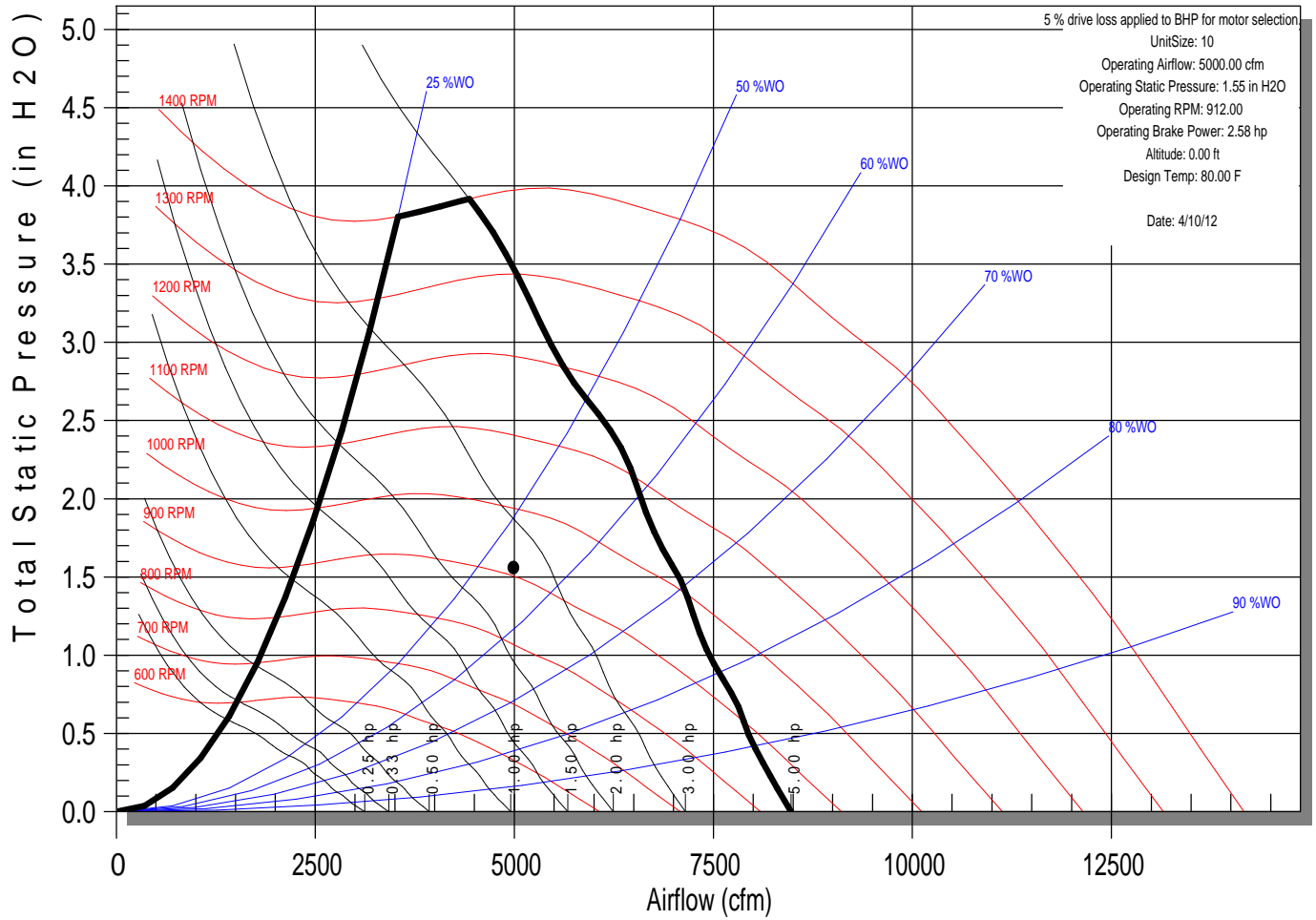

Fan Curve - Packaged Air Handling Units

Item: C2 Qty: 2 Tag(s): Zone 2 AHU, Zone 3 AHU

SIZE 12 HORIZONTAL/ FRONT TOP

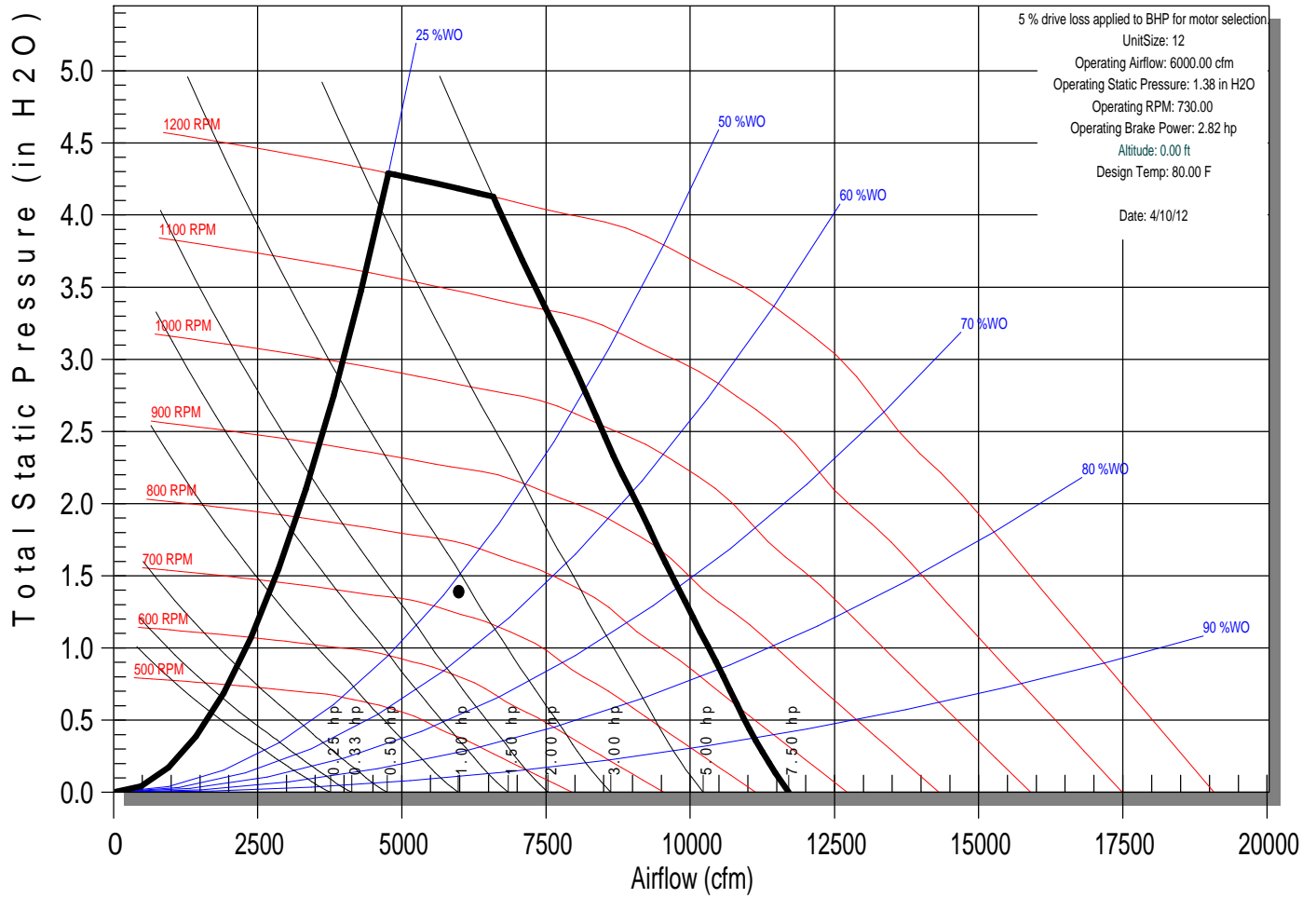

Fan Curve - Packaged Air Handling Units
Item: C3 Qty: 1 Tag(s): Zone 8 AHU

SIZE 17 HORIZONTAL/ FRONT TOP

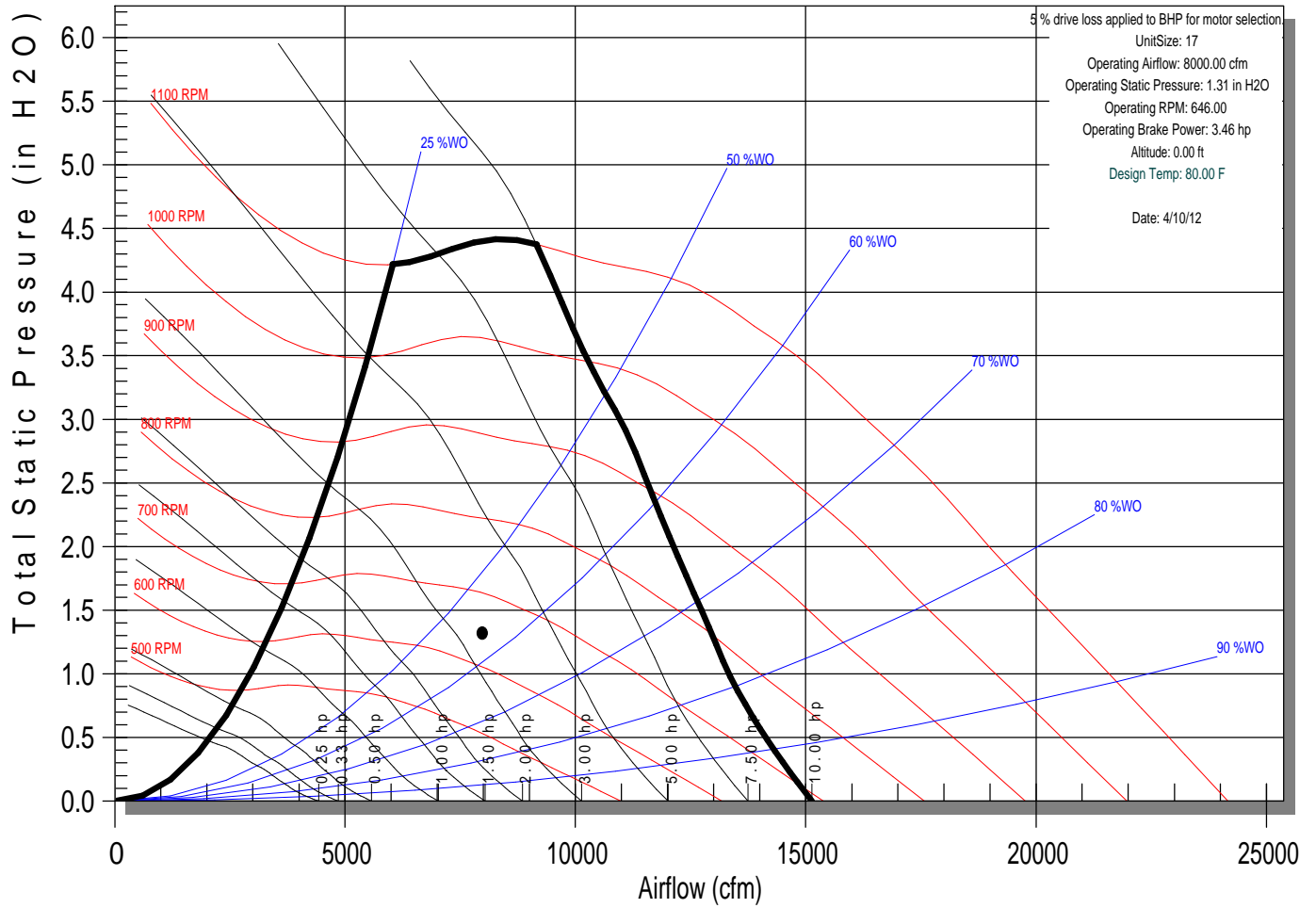

Weight, Clearance & Rigging Diagram - Packaged Air Handling Units

Item: C1 Qty: 2 Tag(s): Zone 5 AHU, Zone 10 AHU

SERVICE CLEARANCE

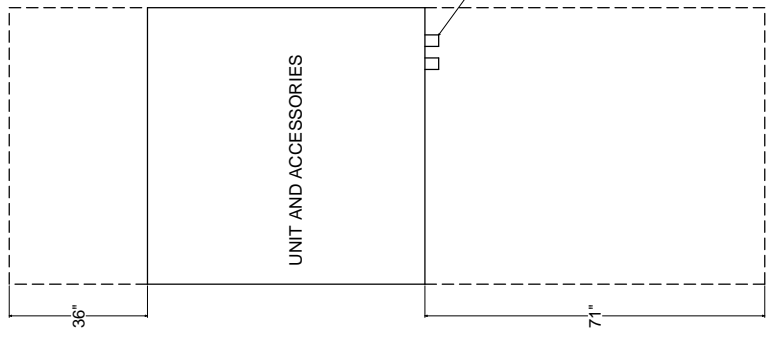

RIGGING

WARNING: DO NOT USE CABLES OR SPREADER BARS EXCEPT AS SHOWN. OTHER LIFTING ARRANGEMENTS COULD CAUSE DEATH OR SERIOUS PERSONAL INJURY OR EQUIPMENT DAMAGE.

EACH OF THE CABLES USED TO LIFT THE UNIT MUST BE CAPABLE OF SUPPORTING THE ENTIRE WEIGHT OF THE UNIT.

BEFORE PREPARING ANY UNIT OR ACCESSORY FOR LIFTING, ESTIMATE THE APPROXIMATE CENTER OF GRAVITY AND TEST LIFT THE UNIT OR ACCESSORY TO DETERMINE BALANCE AND STABILITY.

ASSEMBLY OF THE UNIT MUST BE PERFORMED AT THE UNIT INSTALLATION SITE. ALWAYS RIG UNITS AND ACCESSORIES AS THEY SHIP FROM THE FACTORY.

DO NOT RIG OR LIFT UNITS OR ACCESSORIES WITH FORK LIFT FORKS.

TO AVOID PERSONAL INJURY OR EQUIPMENT DAMAGE, DO NOT LIFT UNITS IN WINDY CONDITIONS OR ABOVE INSTALLATION PERSONNEL.

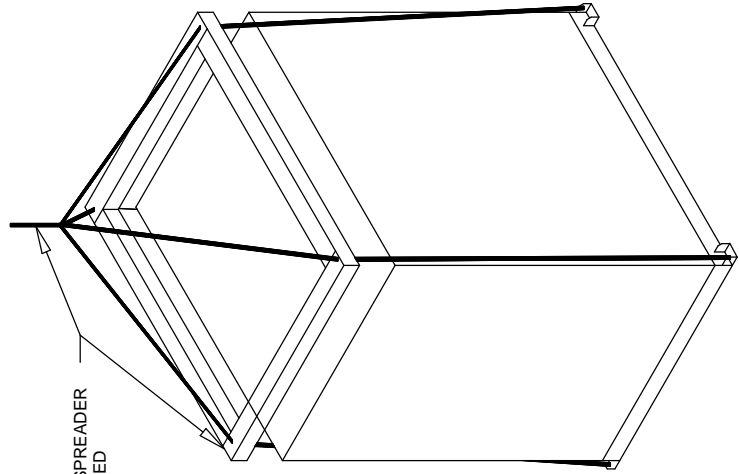

SHIPPING WEIGHTS

BASIC UNIT	COIL 1	COIL 2	MOTOR	ACCESS SECTION	FILTER SECTION	MIXING SECTION	ELECTRIC HEAT	VFD	FACE/BYPASS SECTION
277.0 lb	120.5 lb		56.0 lb			168.0 lb			

Weight, Clearance & Rigging Diagram - Packaged Air Handling Units

Item: C2 Qty: 2 Tag(s): Zone 2 AHU, Zone 3 AHU

SERVICE CLEARANCE

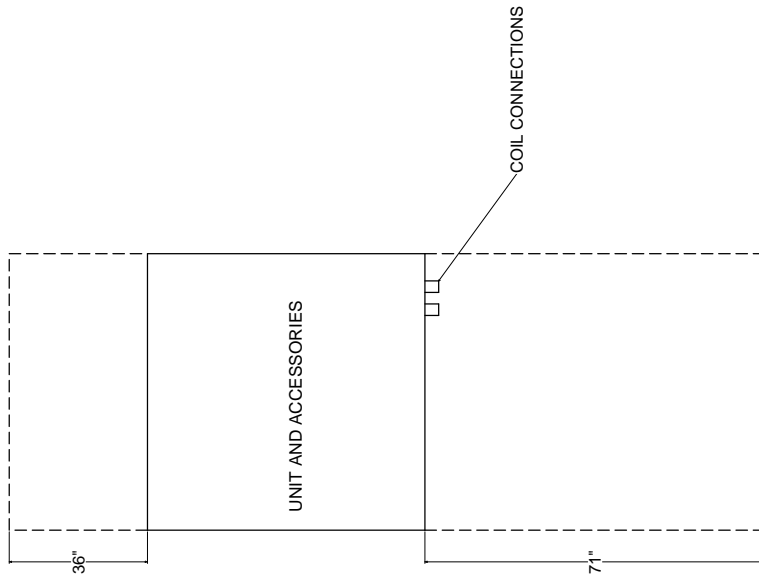

RIGGING

WARNING: DO NOT USE CABLES OR SPREADER BARS EXCEPT AS SHOWN. OTHER LIFTING ARRANGEMENTS COULD CAUSE DEATH OR SERIOUS PERSONAL INJURY OR EQUIPMENT DAMAGE.

EACH OF THE CABLES USED TO LIFT THE UNIT MUST BE CAPABLE OF SUPPORTING THE ENTIRE WEIGHT OF THE UNIT.

BEFORE PREPARING ANY UNIT OR ACCESSORY FOR LIFTING, ESTIMATE THE APPROXIMATE CENTER OF GRAVITY AND TEST LIFT THE UNIT OR ACCESSORY TO DETERMINE BALANCE AND STABILITY.

ASSEMBLY OF THE UNIT MUST BE PERFORMED AT THE UNIT INSTALLATION SITE. ALWAYS RIG UNITS AND ACCESSORIES AS THEY SHIP FROM THE FACTORY.

DO NOT RIG OR LIFT UNITS OR ACCESSORIES WITH FORK LIFT FORKS.

TO AVOID PERSONAL INJURY OR EQUIPMENT DAMAGE, DO NOT LIFT UNITS IN WINDY CONDITIONS OR ABOVE INSTALLATION PERSONNEL.

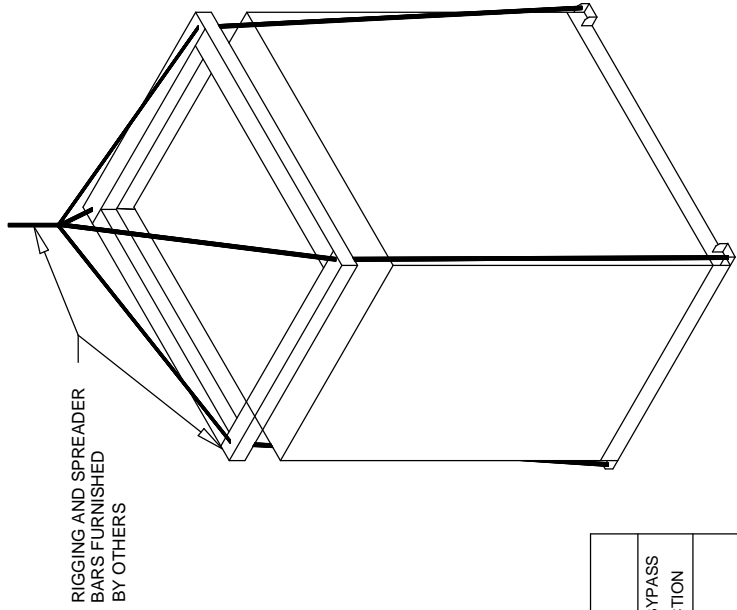

SHIPPING WEIGHTS

BASIC UNIT	COIL 1	COIL 2	MOTOR	ACCESS SECTION	FILTER SECTION	MIXING SECTION	ELECTRIC HEAT	VFD	FACE/BYPASS SECTION
462.0 lb	152.8 lb		56.0 lb			186.0 lb			

Weight, Clearance & Rigging Diagram - Packaged Air Handling Units

Item: C3 Qty: 1 Tag(s): Zone 8 AHU

SERVICE CLEARANCE

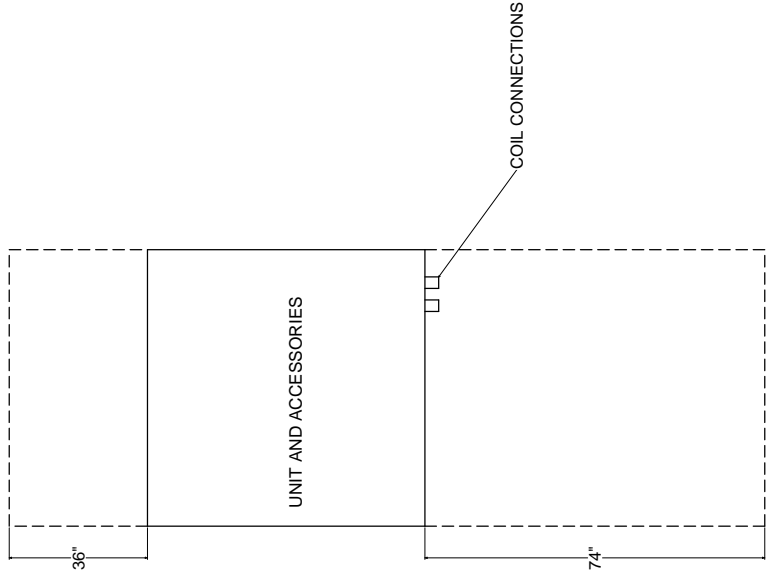

RIGGING

WARNING: DO NOT USE CABLES OR SPREADER BARS EXCEPT AS SHOWN. OTHER LIFTING ARRANGEMENTS COULD CAUSE DEATH OR SERIOUS PERSONAL INJURY OR EQUIPMENT DAMAGE.

EACH OF THE CABLES USED TO LIFT THE UNIT MUST BE CAPABLE OF SUPPORTING THE ENTIRE WEIGHT OF THE UNIT.

BEFORE PREPARING ANY UNIT OR ACCESSORY FOR LIFTING, ESTIMATE THE APPROXIMATE CENTER OF GRAVITY AND TEST LIFT THE UNIT OR ACCESSORY TO DETERMINE BALANCE AND STABILITY.

ASSEMBLY OF THE UNIT MUST BE PERFORMED AT THE UNIT INSTALLATION SITE. ALWAYS RIG UNITS AND ACCESSORIES AS THEY SHIP FROM THE FACTORY.

DO NOT RIG OR LIFT UNITS OR ACCESSORIES WITH FORK LIFT FORKS.

TO AVOID PERSONAL INJURY OR EQUIPMENT DAMAGE, DO NOT LIFT UNITS IN WINDY CONDITIONS OR ABOVE INSTALLATION PERSONNEL.

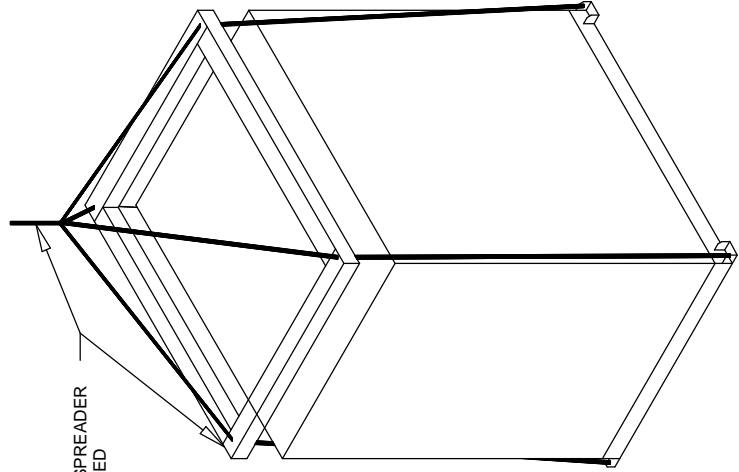

SHIPPING WEIGHTS

BASIC UNIT	COIL 1	COIL 2	MOTOR	ACCESS SECTION	FILTER SECTION	MIXING SECTION	ELECTRIC HEAT	VFD	FACE/BYPASS SECTION
594.0 lb	207.3 lb		82.0 lb			274.0 lb			

Accessory - Packaged Air Handling Units

Item: C1 Qty: 2 Tag(s): Zone 5 AHU, Zone 10 AHU

MIXING SECTION

- NOTES:
1. MIXING BOX SECTION SHIPS ASSEMBLED FOR FIELD INSTALLATION.
 2. LINKAGE BETWEEN DAMPERS FACTORY INSTALLED INSIDE MIXING BOX ON DRIVE SIDE.

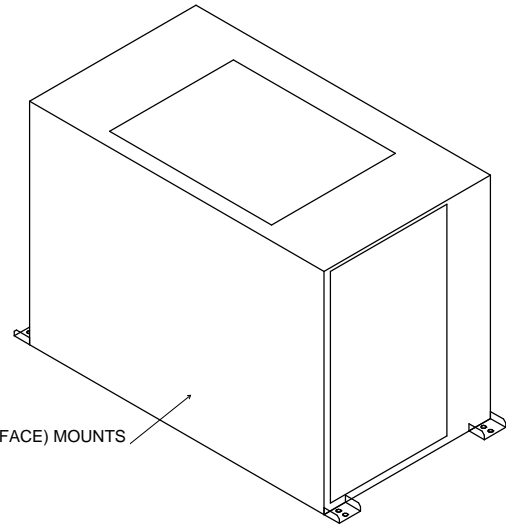
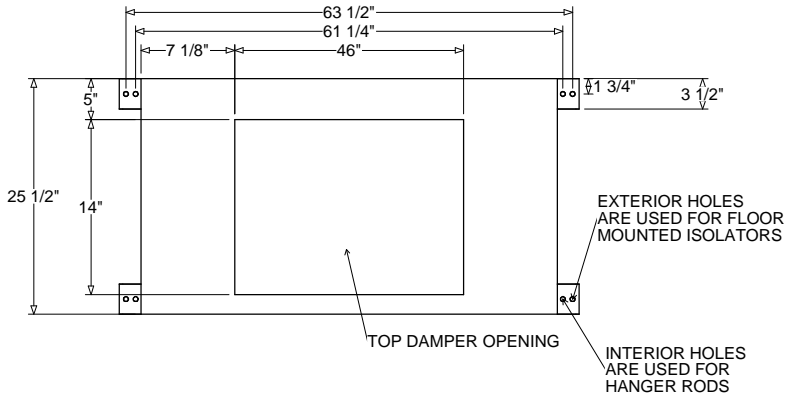

TOP

FRONT ISO

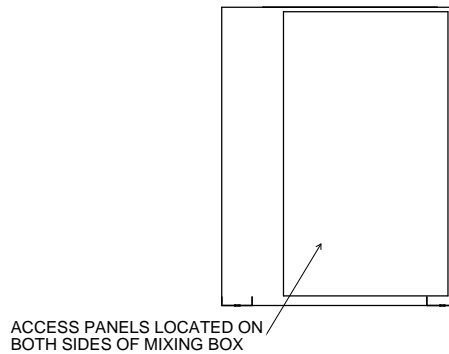
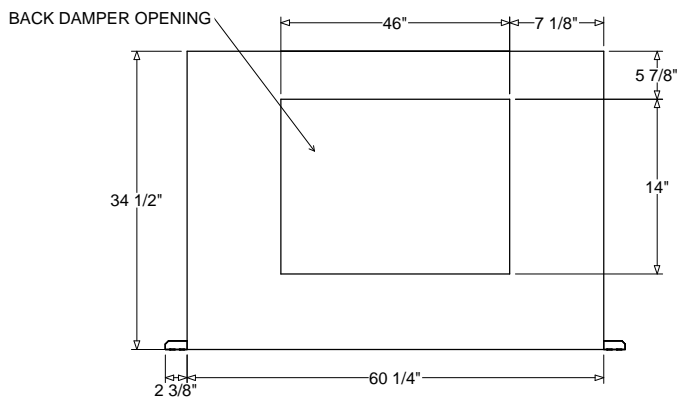

BACK

LEFT

Accessory - Packaged Air Handling Units

Item: C2 Qty: 2 Tag(s): Zone 2 AHU, Zone 3 AHU

MIXING SECTION

- NOTES:
1. MIXING BOX SECTION SHIPS ASSEMBLED FOR FIELD INSTALLATION.
 2. LINKAGE BETWEEN DAMPERS FACTORY INSTALLED INSIDE MIXING BOX ON DRIVE SIDE.

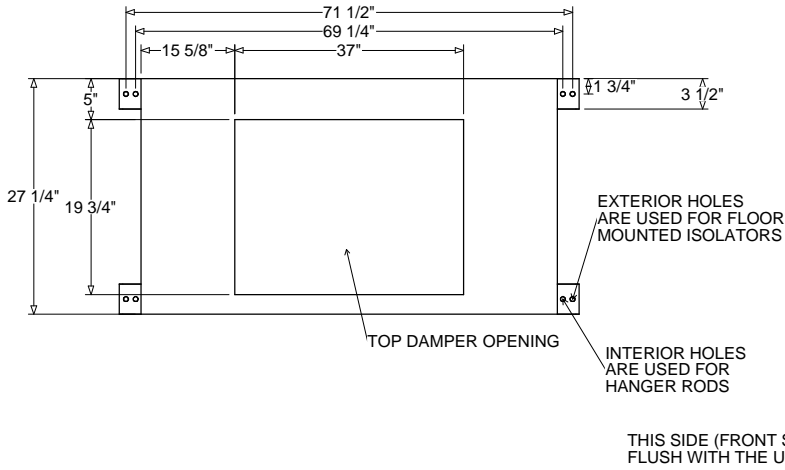

TOP

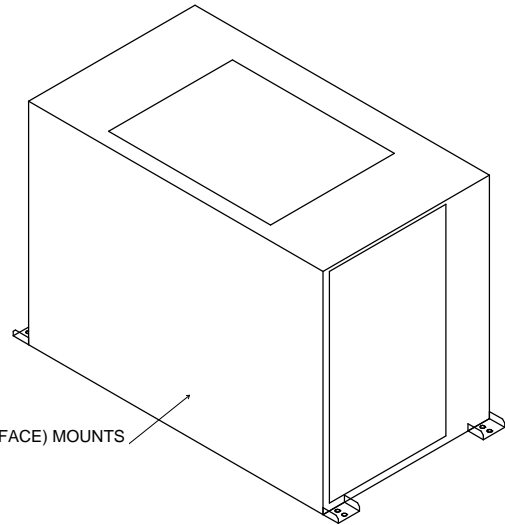

FRONT ISO

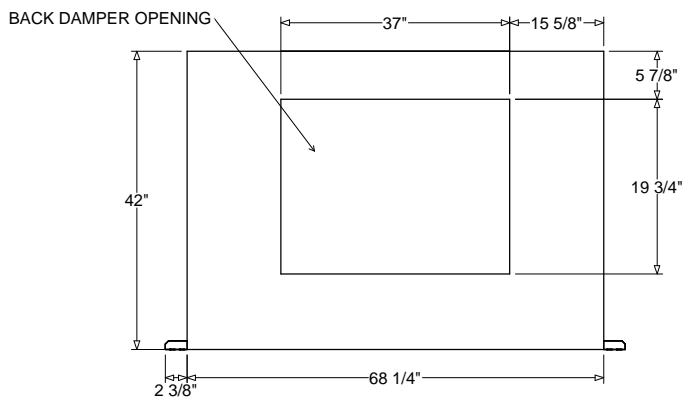

BACK

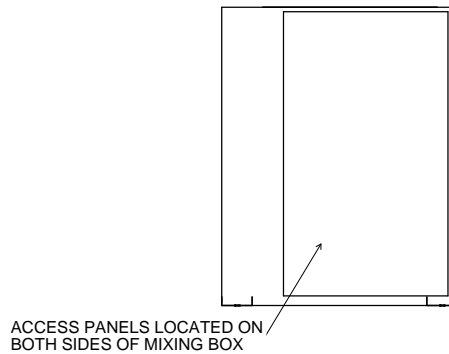

LEFT

Accessory - Packaged Air Handling Units

Item: C3 Qty: 1 Tag(s): Zone 8 AHU

MIXING SECTION

- NOTES:
1. MIXING BOX SECTION SHIPS ASSEMBLED FOR FIELD INSTALLATION.
 2. LINKAGE BETWEEN DAMPERS FACTORY INSTALLED INSIDE MIXING BOX ON DRIVE SIDE.

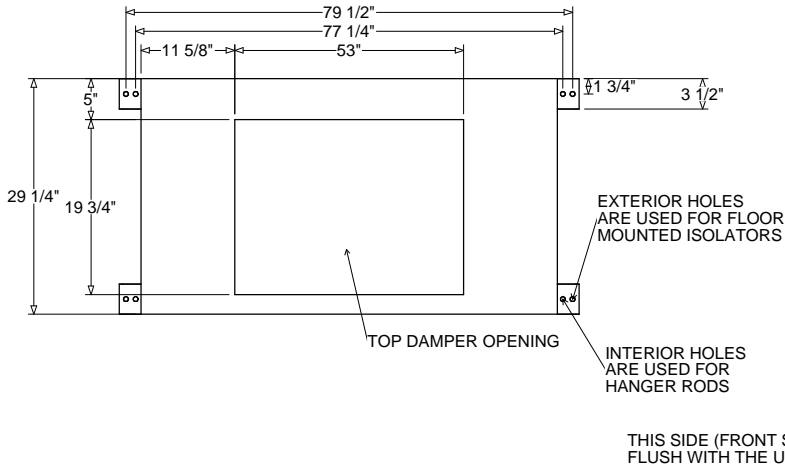

TOP

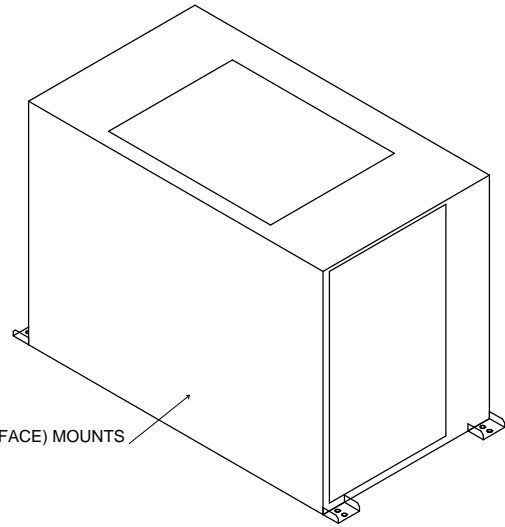

FRONT ISO

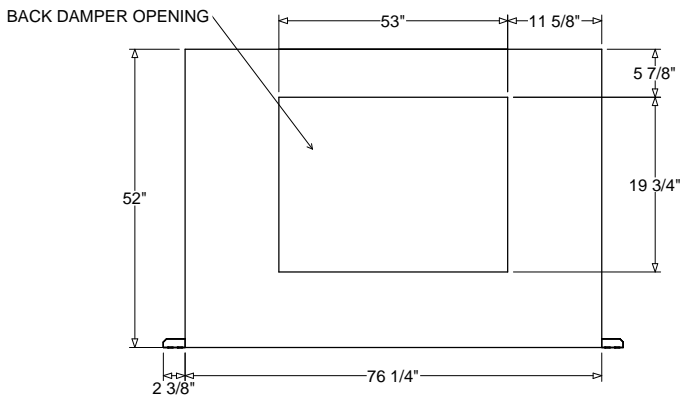

BACK

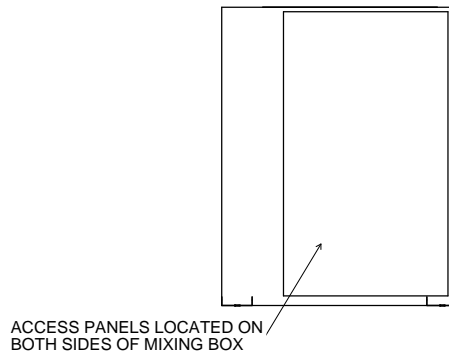

LEFT

Field Wiring - Packaged Air Handling Units

Item: C1, C2 Qty: 4 Tag(s): Zone 5 AHU, Zone 10 AHU, Zone 2 AHU, Zone 3 AHU

POWER WIRING

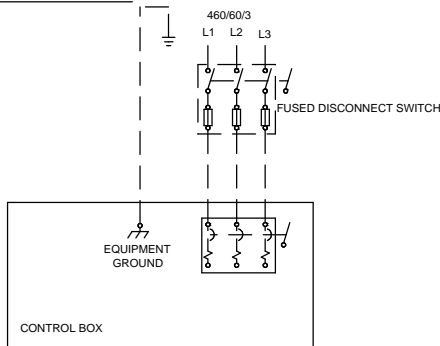

A CIRCUIT BREAKER IS PROVIDED ON ALL 3 PHASE UNITS WITHOUT A VFD.

1. UNLESS OTHERWISE NOTED, ALL SWITCHES ARE SHOWN AT 25°C (77°F), AT ATMOSPHERIC PRESSURE, AT 50% RELATIVE HUMIDITY, WITH ALL UTILITIES TURNED OFF, AND AFTER A NORMAL SHUTDOWN HAS OCCURRED.
2. DASHED LINES INDICATE RECOMMENDED FIELD WIRING BY OTHERS; DASHED LINE ENCLOSURES AND/OR DASHED DEVICE OUTLINES INDICATE COMPONENTS PROVIDED BY THE FIELD. SOLID LINES INDICATE WIRING BY TRANE CO.
3. ALL FIELD WIRING MUST BE IN ACCORDANCE WITH THE NATIONAL ELECTRIC CODE (NEC), STATE AND LOCAL REQUIREMENTS.

4

6

DISCHARGE AIR THERMISTOR RESISTANCE RATING IS 10,000 OHMS @ 25°C ±1°.

CONTROL WIRING

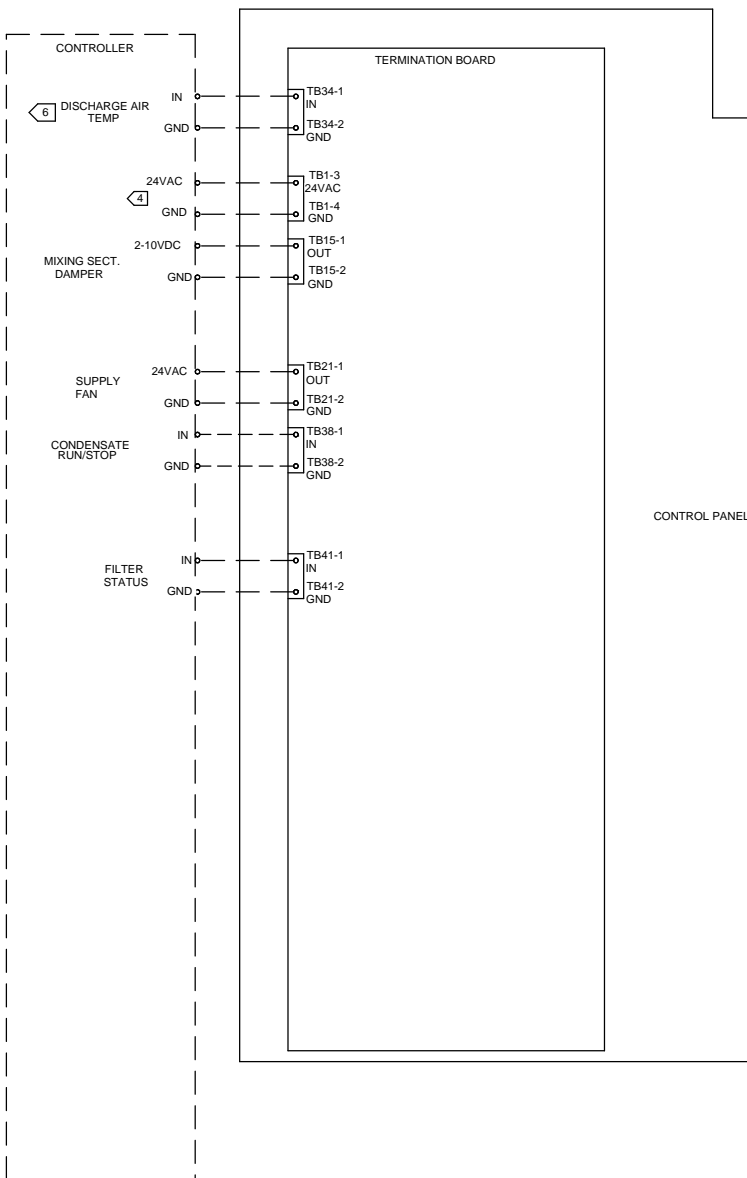

<p>⚠ WARNING</p> <p>HAZARDOUS VOLTAGE! DISCONNECT ALL ELECTRIC POWER INCLUDING REMOTE DISCONNECTS AND FOLLOW LOCK OUT AND TAG PROCEDURES BEFORE SERVICING. INSURE THAT ALL MOTOR CAPACITORS HAVE DISCHARGED STORED VOLTAGE. UNITS WITH VARIABLE SPEED DRIVE, REFER TO DRIVE INSTRUCTIONS FOR CAPACITOR DISCHARGE. FAILURE TO DO THE ABOVE COULD RESULT IN DEATH OR SERIOUS INJURY.</p>	<p>⚠ AVERTISSEMENT</p> <p>TENSION DANGEREUSE! COUPER TOUTES LES TENSIONS ET OUVRIER LES SECTIONNEURS A DISTANCE. PUIS SUIVRE LES PROCEDURES DE VERROUILLAGE ET DES ETIQUETTES AVANT TOUTE INTERVENTION. VERIFIER QUE TOUTS LES CONDENSATEURS DES MOTEURS SONT DECHARGES. DANS LE CAS D'UNITES COMPORTANT DES ENTRAÎNEMENTS A VITESSE VARIABLE, SE REPORTER AUX INSTRUCTIONS DE L'ENTRAÎNEMENT POUR DECHARGER LES CONDENSATEURS.</p>	<p>⚠ ADVERTENCIA</p> <p>¡VOLTAJE PELIGROSO! DESCONECTE TODA LA ENERGIA ELECTRICA, INCLUIDO LAS DESCONEXIONES REMOTAS Y SIGA LOS PROCEDIMIENTOS DE CIERRE Y ETIQUETADO ANTES DE PROCEDER AL SERVICIO. ASEGURESE DE QUE TODOS LOS CAPACITORES DEL MOTOR HAYAN DESCARGADO EL VOLTAJE ALMACENADO PARA LAS UNIDADES CON TRANSMISION DE VELOCIDAD VARIABLE. CONSULTE LAS INSTRUCCIONES PARA LA DESCARGA DEL CONDENSADOR.</p>
---	--	---

MCA: 5.00 A
MFS: 15.00 A

NOTICE

USE COPPER CONDUCTORS ONLY!
UNIT TERMINALS ARE NOT DESIGNED TO ACCEPT OTHER TYPES OF CONDUCTORS.
FAILURE TO DO THE ABOVE COULD RESULT IN EQUIPMENT DAMAGE.

AVIS

N'UTILISER QUE DES CONDUCTEURS EN CUIVRE!
LES BORNES DE L'UNITÉ NE SONT PAS CONÇUES POUR RECEVOIR D'AUTRES TYPES DE CONDUCTEURS.
FAIRE DÉFAUT À LA PROCÉDURE CI-DESSUS PEUT ENTRAÎNER DES DOMMAGES À L'ÉQUIPEMENT.

AVISO

¡UTILICE ÚNICAMENTE CONDUCTORES DE COBRE!
LAS TERMINALES DE LA UNIDAD NO ESTÁN DISEÑADAS PARA ACEPTAR OTROS TIPOS DE CONDUCTORES.
NO SEGUIR LAS INSTRUCCIONES ANTERIORES PUEDE PROVOCAR DAÑOS EN EL EQUIPO.

Field Wiring - Packaged Air Handling Units

Item: C1 - C3 Qty: 5 Tag(s): Zone 5 AHU, Zone 10 AHU, Zone 2 AHU, Zone 3 AHU, Zone 8 AHU

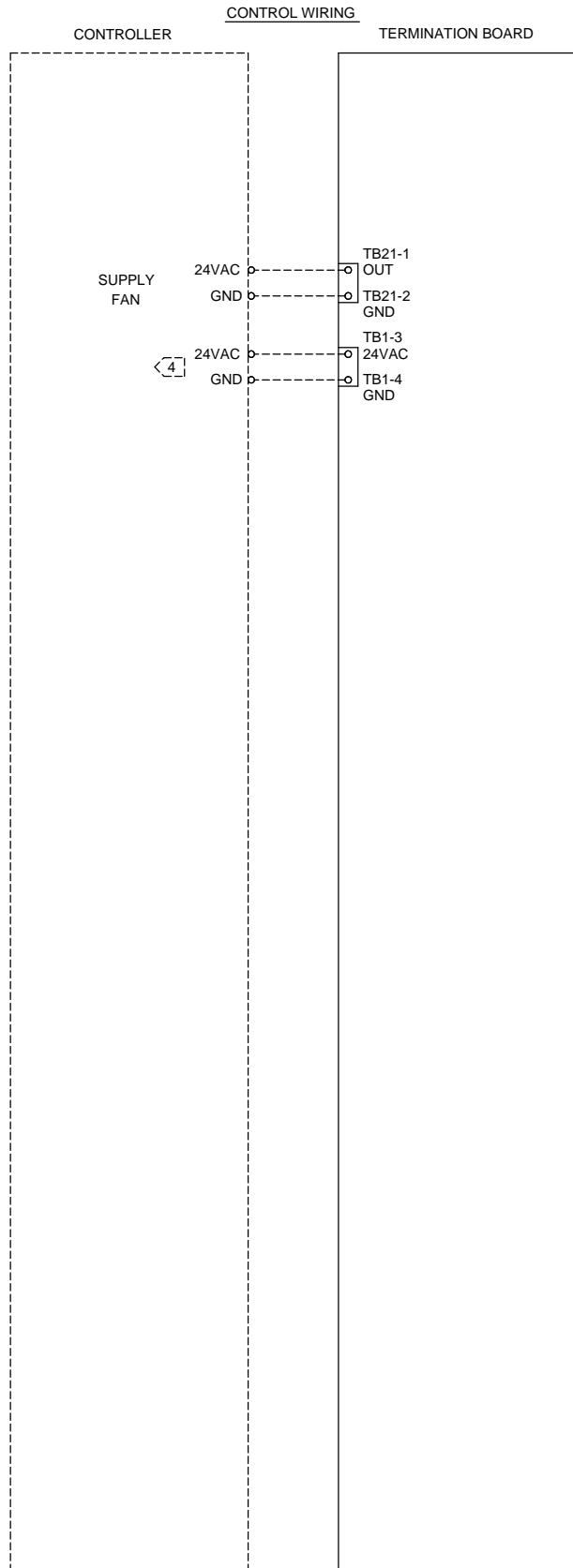

NOTES:
 1. UNLESS OTHERWISE NOTED, ALL SWITCHES ARE SHOWN AT 25°C (77°F), AT ATMOSPHERIC PRESSURE, AT 50% RELATIVE HUMIDITY, WITH ALL UTILITIES TURNED OFF, AND AFTER A NORMAL SHUTDOWN HAS OCCURRED.
 2. DASHED LINES INDICATE RECOMMENDED FIELD WIRING BY OTHERS. DASHED LINE ENCLOSURES AND/OR DASHED DEVICE OUTLINES INDICATE COMPONENTS PROVIDED BY THE FIELD. SOLID LINES INDICATE WIRING BY TRANE CO.
 3. ALL FIELD WIRING MUST BE IN ACCORDANCE WITH THE NATIONAL ELECTRIC CODE (NEC), STATE AND LOCAL REQUIREMENTS.
 4. POWER AVAILABLE FOR FIELD SUPPLIED CONTROLLER IS 24VAC 26VA.

 WARNING HAZARDOUS VOLTAGE! DISCONNECT ALL ELECTRIC POWER INCLUDING REMOTE DISCONNECTS AND FOLLOW LOCK OUT AND TAG PROCEDURES BEFORE SERVICING. INSURE THAT ALL MOTOR CAPACITORS HAVE DISCHARGED STORED VOLTAGE. UNITS WITH VARIABLE SPEED DRIVE, REFER TO DRIVE INSTRUCTIONS FOR CAPACITOR DISCHARGE. FAILURE TO DO THE ABOVE COULD RESULT IN DEATH OR SERIOUS INJURY.	 AVERTISSEMENT TENSION DANGEREUSE! COUPER TOUTES LES TENSIONS ET OUVRIRE LES SECTIONNEURS A DISTANCE, PUIS SUIVRE LES PROCEDURES DE VERROUILLAGE ET DES ETIQUETTES AVANT TOUTE INTERVENTION. VERIFIER QUE TOUTS LES CONDENSATEURS DES MOTEURS SONT DECHARGES. DANS LE CAS D'UNITES COMPORTANT DES ENTRAÎNEMENTS A VITESSE VARIABLE, SE REPORTER AUX INSTRUCTIONS DE L'ENTRAÎNEMENT POUR DECHARGER LES CONDENSATEURS. NE PAS RESPECTER CES MESURES DE PRECAUTION PEUT ENTRAÎNER DES BLESSURES GRAVES POUVANT ÊTRE MORTELLES.	 ADVERTENCIA ¡VOLTAJE PELIGROSO! DESCONECTE TODA LA ENERGÍA ELÉCTRICA, INCLUIDO LAS DESCONEXIONES REMOTAS Y SIGA LOS PROCEDIMIENTOS DE CIERRE Y ETIQUETADO ANTES DE PROCEDER AL SERVICIO. ASEGURESE DE QUE TODOS LOS CAPACITORES DEL MOTOR HAYAN DESCARGADO EL VOLTAJE ALMACENADO. PARA LAS UNIDADES CON TRANSMISIÓN DE VELOCIDAD VARIABLE, CONSULTE LAS INSTRUCCIONES PARA LA DESCARGA DEL CONDENSADOR. EL NO REALIZAR LO ANTERIORMENTE INDICADO, PODRÍA OCASIONAR LA MUERTE O SERIAS LESIONES PERSONALES.
--	--	--

NOTICE USE COPPER CONDUCTORS ONLY! UNIT TERMINALS ARE NOT DESIGNED TO ACCEPT OTHER TYPES OF CONDUCTORS. FAILURE TO DO THE ABOVE COULD RESULT IN EQUIPMENT DAMAGE.
AVIS N'UTILISER QUE DES CONDUCTEURS EN CUIVRE! LES BORNES DE L'UNITÉ NE SONT PAS CONÇUES POUR RECEVOIR D'AUTRES TYPES DE CONDUCTEURS. FAIRE DÉFAUT À LA PROCÉDURE CI-DESSUS PEUT ENTRAÎNER DES DOMMAGES À L'ÉQUIPEMENT.
AVISO ¡UTILICE ÚNICAMENTE CONDUCTORES DE COBRE! LAS TERMINALES DE LA UNIDAD NO ESTÁN DISEÑADAS PARA ACEPTAR OTROS TIPOS DE CONDUCTORES. NO SEGUIR LAS INSTRUCCIONES ANTERIORES PUEDE PROVOCAR DAÑOS EN EL EQUIPO.

Field Wiring - Packaged Air Handling Units

Item: C1 - C3 Qty: 5 Tag(s): Zone 5 AHU, Zone 10 AHU, Zone 2 AHU, Zone 3 AHU, Zone 8 AHU

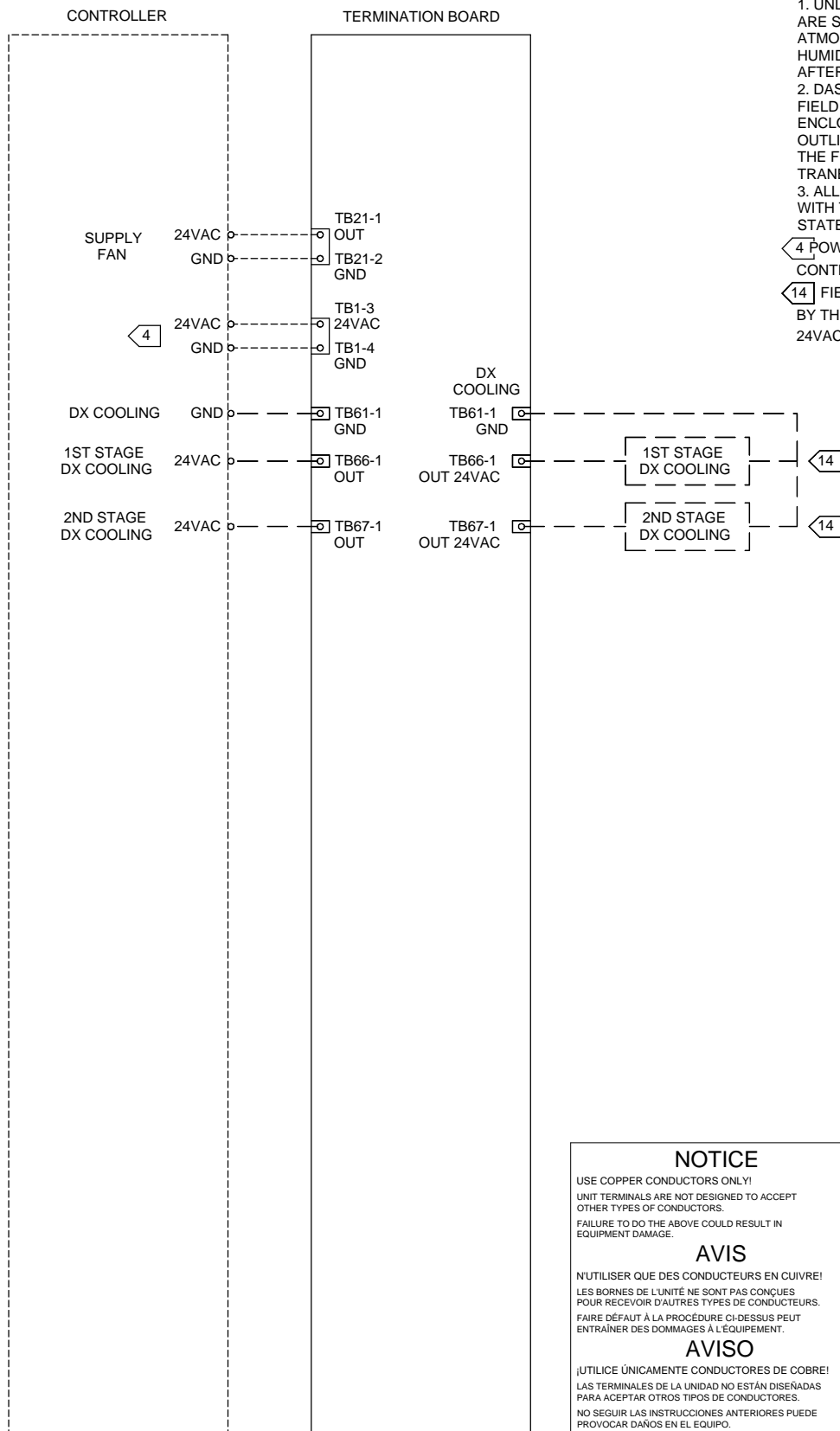

NOTES:

1. UNLESS OTHERWISE NOTED, ALL SWITCHES ARE SHOWN AT 25°C (77°F), AT ATMOSPHERIC PRESSURE, AT 50% RELATIVE HUMIDITY, WITH ALL UTILITIES TURNED OFF, AND AFTER A NORMAL SHUTDOWN HAS OCCURED.
 2. DASHED LINES INDICATE RECOMMENDED FIELD WIRING BY OTHERS. DASHED LINE ENCLOSURES AND / OR DASHED DEVICE OUTLINES INDICATE COMPONENTS PROVIDED BY THE FIELD. SOLID LINES INDICATE WIRING BY TRANE CO.
 3. ALL FIELD WIRING MUST BE IN ACCORDANCE WITH THE NATIONAL ELECTRIC CODE (NEC), STATE AND LOCAL REQUIREMENTS.
- ◀ 4 POWER AVAILABLE FOR FIELD SUPPLIED CONTROLLER IS 24VAC 26VA.
- ◀ 14 FIELD SUPPLIED CONTROL RELAYS POWERED BY THIS UNIT MUST BE PILOT DUTY RATED, 24VAC COIL, 6VA MAX.

⚠ WARNING

HAZARDOUS VOLTAGE!

DISCONNECT ALL ELECTRIC POWER INCLUDING REMOTE DISCONNECTS AND FOLLOW LOCK OUT AND TAG PROCEDURES BEFORE SERVICING. INSURE THAT ALL MOTOR CAPACITORS HAVE DISCHARGED STORED VOLTAGE. UNITS WITH VARIABLE SPEED DRIVE, REFER TO DRIVE INSTRUCTIONS FOR CAPACITOR DISCHARGE. FAILURE TO DO THE ABOVE COULD RESULT IN DEATH OR SERIOUS INJURY.

⚠ AVERTISSEMENT

TENSION DANGEREUSE!

COUPER TOUTES LES TENSIONS ET OUVRIER LES SECTIONNEURS À DISTANCE, PUIS SUIVRE LES PROCÉDURES DE VERROUILLAGE ET DES ÉTIQUETTES AVANT TOUTE INTERVENTION. VÉRIFIER QUE TOUS LES CONDENSATEURS DES MOTEURS SONT DÉCHARGÉS. DANS LE CAS D'UNITÉS COMPORTANT DES ENTRAÎNEMENTS À VITESSE VARIABLE, SE REPORTER AUX INSTRUCTIONS DE L'ENTRAÎNEMENT POUR DÉCHARGER LES CONDENSATEURS.

NE PAS RESPECTER CES MESURES DE PRÉCAUTION PEUT ENTRAÎNER DES BLESSURES GRAVES POUVANT ÊTRE MORTELLES.

⚠ ADVERTENCIA

¡VOLTAJE PELIGROSO!

DESCONECTE TODA LA ENERGÍA ELÉCTRICA, INCLUSO LAS DESCONEXIONES REMOTAS Y SIGA LOS PROCEDIMIENTOS DE CIERRE Y ETIQUETADO ANTES DE PROCEDER AL SERVICIO. ASEGÚRESE DE QUE TODOS LOS CAPACITORES DEL MOTOR HAYAN DESCARGADO EL VOLTAJE ALMACENADO. PARA LAS UNIDADES CON TRANSMISIÓN DE VELOCIDAD VARIABLE, CONSULTE LAS INSTRUCCIONES PARA LA DESCARGA DEL CONDENSADOR.

EL NO REALIZAR LO ANTERIORMENTE INDICADO, PODRÍA OCASIONAR LA MUERTE O SERIAS LESIONES PERSONALES.

NOTICE

USE COPPER CONDUCTORS ONLY!
UNIT TERMINALS ARE NOT DESIGNED TO ACCEPT OTHER TYPES OF CONDUCTORS.
FAILURE TO DO THE ABOVE COULD RESULT IN EQUIPMENT DAMAGE.

AVIS

N'UTILISER QUE DES CONDUCTEURS EN CUIVRE!
LES BORNES DE L'UNITÉ NE SONT PAS CONÇUES POUR RECEVOIR D'AUTRES TYPES DE CONDUCTEURS.
FAIRE DÉFAUT À LA PROCÉDURE CI-DESSUS PEUT ENTRAÎNER DES DOMMAGES À L'ÉQUIPEMENT.

AVISO

¡UTILICE ÚNICAMENTE CONDUCTORES DE COBRE!
LAS TERMINALES DE LA UNIDAD NO ESTÁN DISEÑADAS PARA ACEPTAR OTROS TIPOS DE CONDUCTORES.
NO SEGUIR LAS INSTRUCCIONES ANTERIORES PUEDE PROVOCAR DAÑOS EN EL EQUIPO.

Field Wiring - Packaged Air Handling Units
Item: C3 Qty: 1 Tag(s): Zone 8 AHU

POWER WIRING

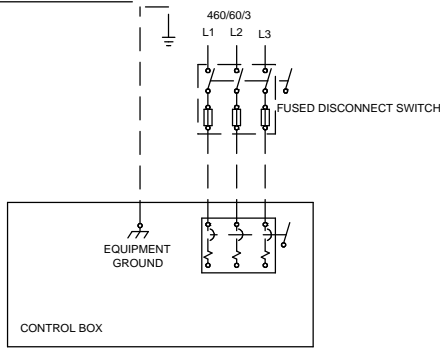

A CIRCUIT BREAKER IS PROVIDED ON ALL 3 PHASE UNITS WITHOUT A VFD.

1. UNLESS OTHERWISE NOTED, ALL SWITCHES ARE SHOWN AT 25°C (77°F), AT ATMOSPHERIC PRESSURE, AT 50% RELATIVE HUMIDITY, WITH ALL UTILITIES TURNED OFF, AND AFTER A NORMAL SHUTDOWN HAS OCCURRED.
2. DASHED LINES INDICATE RECOMMENDED FIELD WIRING BY OTHERS; DASHED LINE ENCLOSURES AND/OR DASHED DEVICE OUTLINES INDICATE COMPONENTS PROVIDED BY THE FIELD. SOLID LINES INDICATE WIRING BY TRANE CO.
3. ALL FIELD WIRING MUST BE IN ACCORDANCE WITH THE NATIONAL ELECTRIC CODE (NEC), STATE AND LOCAL REQUIREMENTS.

4

6

DISCHARGE AIR THERMISTOR RESISTANCE RATING IS 10,000 OHMS @ 25°C ±1°.

CONTROL WIRING

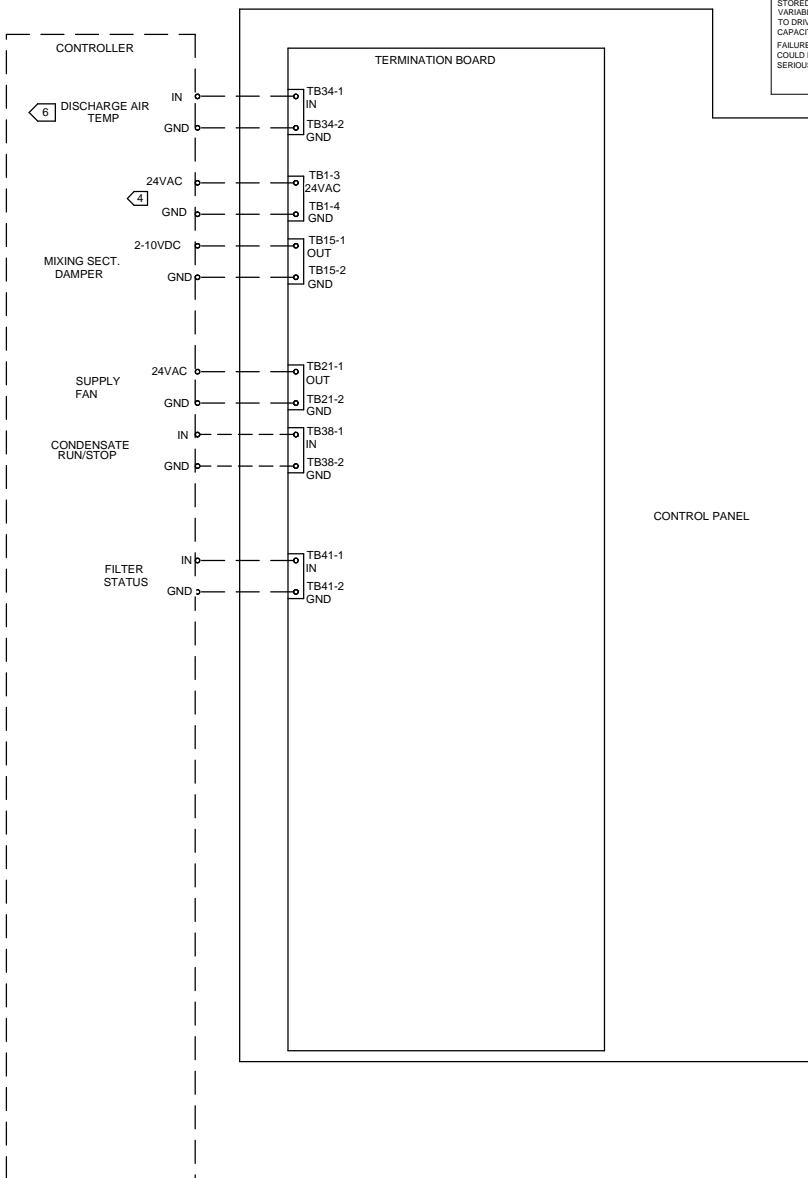

<p>⚠ WARNING</p> <p>HAZARDOUS VOLTAGE! DISCONNECT ALL ELECTRIC POWER INCLUDING REMOTE DISCONNECTS AND FOLLOW LOCK OUT AND TAG PROCEDURES BEFORE SERVICING. INSURE THAT ALL MOTOR CAPACITORS HAVE DISCHARGED STORED VOLTAGE. UNITS WITH VARIABLE SPEED DRIVE, REFER TO DRIVE INSTRUCTIONS FOR CAPACITOR DISCHARGE. FAILURE TO DO THE ABOVE COULD RESULT IN DEATH OR SERIOUS INJURY.</p>	<p>⚠ AVERTISSEMENT</p> <p>TENSION DANGEREUSE! COUPER TOUTES LES TENSIONS ET OUVRIER LES SECTIONNEURS A DISTANCE. PUIS SUIVRE LES PROCEDURES DE VERROUILLAGE ET DES ETIQUETTES AVANT TOUTE INTERVENTION. VERIFIER QUE TOUTS LES CONDENSATEURS DES MOTEURS SONT DECHARGES. DANS LE CAS D'UNITES COMPORTANT DES ENTRAÎNEMENTS A VITESSE VARIABLE, SE REPORTER AUX INSTRUCTIONS DE L'ENTRAÎNEMENT POUR DECHARGER LES CONDENSATEURS.</p>	<p>⚠ ADVERTENCIA</p> <p>¡VOLTAJE PELIGROSO! DESCONECTE TODA LA ENERGIA ELECTRICA, INCLUIDO LAS DESCONEXIONES REMOTAS Y SIGA LOS PROCEDIMIENTOS DE CIERRE Y ETIQUETADO ANTES DE PROCEDER AL SERVICIO. ASEGURESE DE QUE TODOS LOS CAPACITORES DEL MOTOR HAYAN DESCARGADO EL VOLTAJE ALMACENADO PARA LAS UNIDADES CON TRANSMISION DE VELOCIDAD VARIABLE. CONSULTE LAS INSTRUCCIONES PARA LA DESCARGA DEL CONDENSADOR.</p>
--	---	--

MCA: 8.25 A
 MFS: 15.00 A

NOTICE

USE COPPER CONDUCTORS ONLY!
 UNIT TERMINALS ARE NOT DESIGNED TO ACCEPT OTHER TYPES OF CONDUCTORS.
 FAILURE TO DO THE ABOVE COULD RESULT IN EQUIPMENT DAMAGE.

AVIS

N'UTILISER QUE DES CONDUCTEURS EN CUIVRE!
 LES BORNES DE L'UNITÉ NE SONT PAS CONÇUES POUR RECEVOIR D'AUTRES TYPES DE CONDUCTEURS.
 FAIRE DÉFAUT A LA PROCÉDURE CI-DESSUS PEUT ENTRAÎNER DES DOMMAGES A L'ÉQUIPEMENT.

AVISO

¡UTILICE ÚNICAMENTE CONDUCTORES DE COBRE!
 LAS TERMINALES DE LA UNIDAD NO ESTÁN DISEÑADAS PARA ACEPTAR OTROS TIPOS DE CONDUCTORES.
 NO SEGUIR LAS INSTRUCCIONES ANTERIORES PUEDE PROVOCAR DAÑOS EN EL EQUIPO.

Field Installed Options - Part/Order Number Summary

This is a report to help you locate field installed options that arrive at the jobsite. This report provides part or order numbers for each field installed option, and references it to a specific product tag. It is NOT intended as a bill of material for the job.

Product Family - Split System Air Conditioning Units (Large)

Item	Tag(s)	Qty	Description	Model Number
A1	Zone 5 CU, Zone 10 CU	2	6 - 20 Ton Unitary Split Systems	TTA150E400----- -000
A2	Zone 2 CU, Zone 3 CU	2	6 - 20 Ton Unitary Split Systems (SSC2	TTA180E400----- -000
A3	Zone 8 CU	1	6 - 20 Ton Unitary Split Systems (SSC2	TTA240E400----- -000

Field Installed Option Description	Part/Ordering Number
Hot gas bypass - mechan. valve R410A	BAYHGBP010B
Lontalk communication interface	BAYLTCI002B

Product Family - Split System Air Conditioning Units (Small)

Item	Tag(s)	Qty	Description	Model Number
B1	Zone 1 Split	1	1 - 6 Ton Unitary Split Systems (SSC)	4TTB3024E1000- GAM5A0000M-1S- 0----000-0--0

Field Installed Option Description	Part/Ordering Number
5.77/7.68 kW Electric Htr w/ Ckt Brk for 208/240V 1 Phase 60 Hz	BAYEAC08BK1AA

Item	Tag(s)	Qty	Description	Model Number
B2	Zone 6 Split	1	1 - 6 Ton Unitary Split Systems (SSC)	4TTA3036A4000- GAM5A0B36M-1S- 0----000-0--0
B3	Zone 7 Split	1	1 - 6 Ton Unitary Split Systems (SSC)	4TTA3048A4000- GAM5A0000M-1S- 0----000-0--0

Field Installed Option Description	Part/Ordering Number
7.21/9.60 kW Electric Htr w/Ckt Brk for 208/240V 1 Phase 60 Hz	BAYEAC10BK1AA