

APPROXIMATE LOCATION OF THE FLOOD ZONE LINE

FLOOD ZONE C
FLOOD ZONE A1

MECHANICAL DR.

J. F. SMITH AVE.
CENTERLINE OF ROADWAY



SITE PLAN
SCALE: 1"=20'-0"

LANDSCAPE LEGEND

- CLASS A TREE ONE FOR EVERY 30 LINEAR FEET OF ROAD FRONTAGE; REAR, SIDE AREAS AND PARKING ISLANDS.
- CLASS B TREE ONE FOR EVERY 30 LINEAR FEET OF ROAD FRONTAGE; REAR, SIDE AREAS AND PARKING ISLANDS.
- ONE SHRUB PER 30 LINEAR FEET OF ROAD FRONTAGE; CONTINUOUS SHRUBS 2'-6" MAX ON CENTER FOR PARKING ADJACENT TO STREET PLANTING AND 1 SHRUB FOR EVERY 20 SQ. FT. IN PEDESTRIAN PLANTING AREAS
- GROUNDCOVER IN ALL AREAS OF PLANTING

LEGEND

- PROPERTY LINE
- SETBACK
- NEW BUILDING OUTLINE
- SERVITUDE / EASEMENT
- HANDICAP PARKING
- HANDICAP PARKING SIGN
- TRAFFIC FLOW DIRECTION

SITE LIGHTING

EXTERIOR LIGHTING SHALL BE SHADED OR INWARDLY DIRECTED IN SUCH A MANNER SO THAT NO DIRECT LIGHTING OR GLARE BE CAST BEYOND THE PROPERTY LINE. THE INTENSITY OF SUCH LIGHTING SHALL NOT EXCEED ONE FOOT CANDLE AS MEASURED AT THE ABUTTING PROPERTY LINE.

PARKING REQUIREMENTS

GROSS BUILDING SQUARE FEET 14,694
OFFICE AREA ONE SPACE PER 300 SQ. FT.
OFFICE AREA 3,620 SQ. FT. = 12 SPACES
WAREHOUSE ONE SPACE PER 1,000 SQ. FT.
WAREHOUSE 11,074 SQ. FT. = 11 SPACES
TOTAL SPACES REQUIRED = 23 SPACES INCLUDING 1 HANDICAP
TOTAL SPACES PROVIDED = 23 SPACES INCLUDING 1 HANDICAP

ZONED M-1

LEGAL DESCRIPTION

LOT 23, JOHNNY F. SMITH MEMORIAL BUSINESS PARK SECTIONS 27, T-8-S, R-14-E, ST. TAMMANY PARISH, LA.

NOTE: SIGNAGE SHALL COMPLY WITH SIGNAGE GUIDELINES

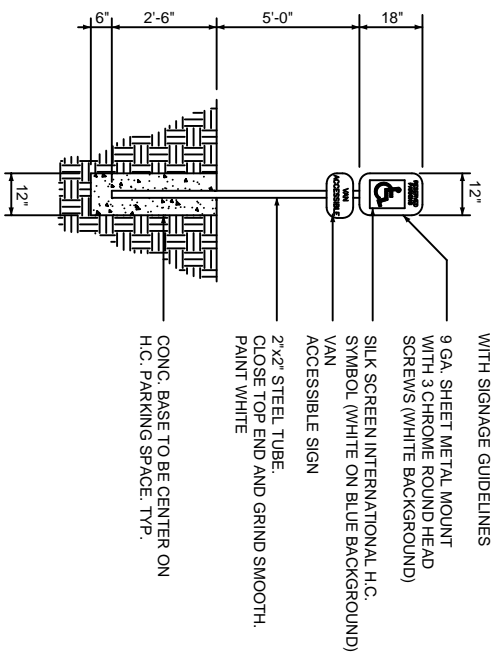

HANDICAP PARKING SIGN

N. T. S.

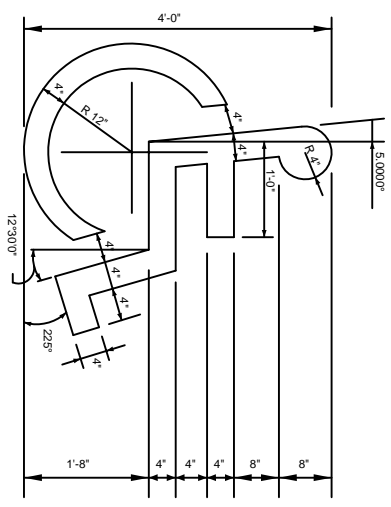

HANDICAP SYMBOL DETAIL

N. T. S.

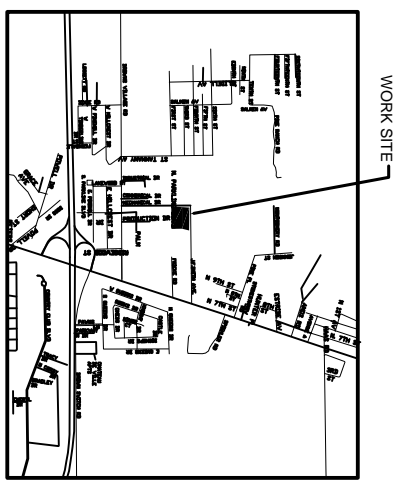

VICINITY MAP
N.T.S.



DAMMON ENGINEERING, INC.

EMMETT DAMMON

ARCHITECT ROBERT WILTSE

1095 FLORIDA AVENUE
SLIDELL, LA, 70458
985-649-5832

WEBSITE: WWW.DAMMONENGINEERING.COM

EMAIL: DAMMONENG@BELL.SOUTH.NET

ARCHITECTURE
ENGINEERING
STUDIES
PLANNING
INVESTIGATION
EXPERT WITNESS

NEW OFFICE/ WAREHOUSE

O'BRIEN / NORTH SHORE FLOORING DISTRIBUTORS
J.F. SMITH AVE.
SLIDELL, LA

SITE PLAN

REV:	
SCALE:	AS NOTED
JOB#:	
DATE:	11-14-07
SHEET	

C-2

OF