

GUTTERS AND DOWN SPOUTS TO BE SEAMLESS ALUMINUM 24 GAUGE, COLOR TO BE SELECTED BY OWNER. GUTTERS TO BE VOGEL IN CROSS SECTION, MINIMUM 6\"

- NOTES:**
- 1) DRAIN PIPE & FITTINGS WITHIN PROPERTY LINE SHALL BE POLYVINYL CHLORIDE PLASTIC PIPE, MEETING CLASS 100 C-900 PVC.
 - 2) ELEVATIONS SHOWN ARE M.S.L.
 - 3) FIELD VERIFY ALL ELEVATIONS AND DRAINAGE SYSTEM PLACEMENT PRIOR TO START OF WORK.
 - 4) MUCK OUT 24\"
 - 5) TO UNDISTURBED SOIL CAPABLE OF 1,500 PSF BEARING.
 - 6) THERE IS NO EVIDENCE OF EXISTING OFF-SITE FLOW CROSSING THE PROPERTY. NEW DRAINAGE CALCULATIONS ARE DETERMINED ACCORDINGLY.

SITE DRAINAGE PLAN
SCALE: 1" = 20'

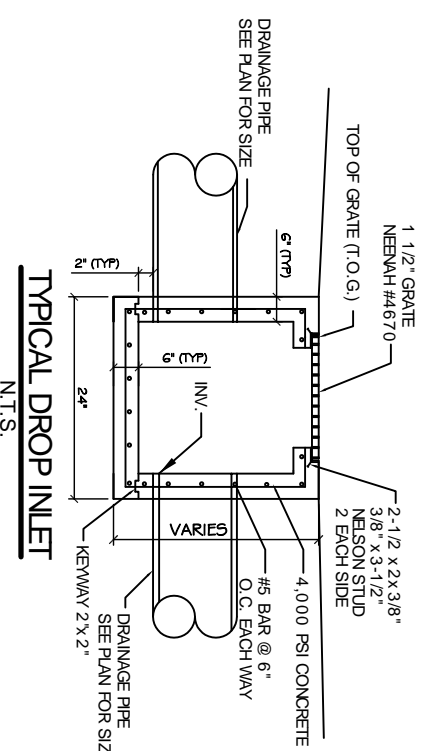

TYPICAL DROP INLET
N.T.S.

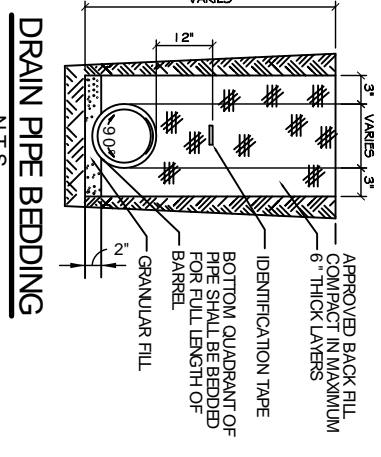

DRAIN PIPE BEDDING
N.T.S.

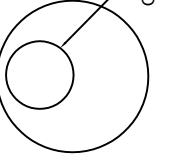

OFFICE DETAIL
N.T.S.

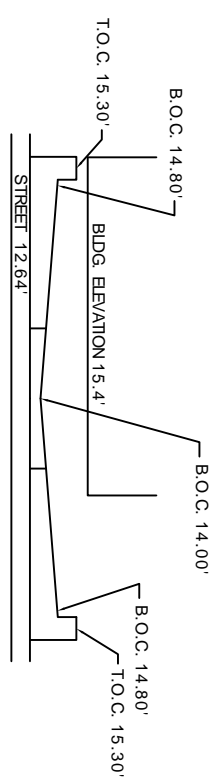

SECTION
N.T.S.

- LEGEND:**
- PROPERTY LINE
 - UTILITY / EASEMENT LINE
 - BUILDING SETBACK MINIMUM
 - LANDSCAPING SETBACK MINIMUM
 - NEW BUILDING
 - NEW BUFFER ZONE LIMITS AT REAR
 - NEW DRAIN LINE
 - NEW DROP INLET w/TBMP
 - SLOPE LINES
 - T.O. GRATE ELEVATION
 - INVERT ELEVATION
 - NEW ELEVATIONS
 - EXISTING ELEVATIONS
 - TEMPORARY SILT FENCING

PROJECT: JD PLAZA

DRAINAGE RUN OFF CALCULATIONS - MODIFIED RATIONAL METHOD

PRIOR DEVELOPMENT
10 Year Frequency

Watersight Surfaces	c(1) =	0.9	sqft =	0.000	Acres
Gravel Surface	c(2) =	0.25	44,987.33	sqft =	1.033
Green Space	c(3) =	0.35	44,987.33	sqft =	1.033
Summary	c =	0.35			

Duration (D) = Time of concentration (TC)
TC = .7039(L + .3817)(c + 1.1309)(S^{-1.1985})
 where L = 236
 Runoff length ft
 S = 0.35
 Percent Slope
 TC = 0 = 26.89
 minutes
 I = 3.50
 in/hr

herefore and from Rainfall Intensity Table

Q₁ = 1.265 cfs **RUNOFF LIMIT 85%** **1.076 cfs**

POST DEVELOPMENT
10 Year Frequency

Q₂ = CIA

Watersight Surfaces	c(1) =	0.9	sqft =	0.625	Acres
Gravel Surface	c(2) =	0.25	17,764.52	sqft =	0.408
Green Space	c(3) =	0.35	44,987.33	sqft =	1.033
Summary	c =	0.68			

D = Time of concentration (TC)
TC = .7039(L + .3817)(c + 1.1309)(S^{-1.1985})
 where L = 178
 Runoff length ft
 S = 0.89
 Percent Slope
 TC = 0 = 9.80
 minutes or
 I = 3.50
 in/hr

herefore and from Rainfall Intensity Table

Q₂ = 2.469 cfs

RESULTS

DETENTION REQUIRED TWO HOUR DETENTION DETENTION DIMENSIONS	Q ₂ - Q ₁	1.393 cfs	WIDTH	100x116	DEPTH	0.52
DISCHARGE END AREA CALCULATIONS			LENGTH	190	DEPTH	102

Q = CA(2gh)^{1/2}

where Q is allowable run off

Q = 1.076 cfs
 C = 0.98 coefficient
 g = 32.2 ft/ft/sec
 h = 2.00 feet
 A = 0.10 sqft

REQUIRED CONDUIT = 4.21 inch diameter

USE 4 inch offset 4 inch offset

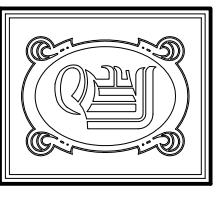

DAMMON ENGINEERING, INC.
 CHIEF ENGINEER
 EMILY DAMMON, P.E.
 CHIEF ARCHITECT
 ROBERT WILTSE

1095 FLORIDA AVENUE
 SUDELL, LA, 70458
 OFFICE: 985-649-5832
 FAX: 985-641-5950
 WWW.DAMMONENGINEERING.COM

ARCHITECTURE
 ENGINEERING
 STUDIES
 PLANNING
 INVESTIGATION
 EXPERT WITNESS

JD PLAZA
345 GAUSE BOULEVARD
WEST SUDELL, LA

SITE DRAINAGE PLAN

REV: SCALE: AS NOTED

JOB#: 2037

DATE: 10-01-09

SHEET 5

C-4