



IIG MinWool, LLC

A Calsiite/Johns Manville Joint Venture

MinWool-1200 Safing

High Temperature Insulation



Description

IIG MinWool-1200 Safing Insulation is made of inorganic fibers derived from basalt, a volcanic rock, with a thermosetting resin binder. Advanced manufacturing technology ensures consistent product quality, with high fiber density and low shot content, for excellent performance. Safing insulation is manufactured in a standard 4" (102 mm) thickness and is available plain or faced with an FSP (Foil-Scrim-Polyethylene) vapor retarder on one face. Custom sizes are available on special order. It is inorganic and will not mildew or support corrosion.

MinWool-1200 Safing is GREENGUARD Indoor Air Quality Certified® for low chemical emissions.

Applications

MinWool-1200 Safing insulation is designed to be installed between the spandrel panel and floor slab in commercial curtainwall systems to provide a fire-rated seal. It also prevents the passage of flame and smoke in openings that penetrate fire-rated assemblies.



Advantages

Unique Bio-Soluble Fiber. IIG MinWool-1200 has been tested and exceeds the regulatory safety for solubility.

Excellent Thermal Performance. Provides excellent thermal properties in all commercial curtainwall systems. MinWool-1200 Safing has an R-Value of 4.0 per inch (0.70 per 25 mm) of thickness.

Superior Fire Safety. MinWool-1200 Safing Insulation has a melting point in excess of 2000°F (1093°C) and the unfaced insulation is classified as noncombustible by the model building codes. When installed in approved systems, the insulation provides up to a three hour fire resistance rating when tested in accordance with ASTM E 119 (UL 263, NFPA 251).

Low Smoke & Flame Spread. When tested in accordance with ASTM E 84, UL 723, CAN/ULC-S102-M, the unfaced insulation has a flame spread rating of 5 and a smoke developed rating of 0. The faced insulation has a flame spread rating of 25 and a smoke developed rating of 5.

Noncombustible. Unfaced MinWool-1200 Safing is rated as noncombustible in accordance with ASTM E 136 and CAN4-S114-M.

Quick Installation. MinWool-1200 Safing Insulation is easy to install. It is easily cut with a utility knife for convenient job site fabrication. It is easy to compress to fit tightly between the curtainwall insulation and the floor slab. MinWool-1200 Safing Insulation is packaged in polyshrink wrap.

Mold Resistant. IIG MinWool-1200 does not support growth of fungus.

Available Types

MinWool-1200 Safing Insulation is available in a standard size of 4" (102 mm) thick by 24" X 48" (610 mm x 1219 mm). MinWool-1200 Safing Insulation can also be furnished in other thicknesses and sizes on special order.

Design Recommendations

MinWool-1200 Safing should be specified to meet building code requirements as a firestop or as part of a fire-rated joint, perimeter,

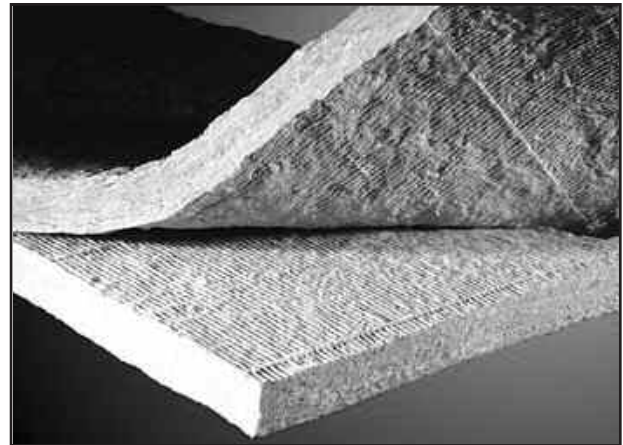

wall floor, ceiling, or other assembly as required. The need for and the placement of a vapor retarder in commercial construction depends on many factors. The architect or specifier should evaluate the requirements of each project.

Installation

MinWool-1200 Safing Insulation is easily cut with a knife for quick installation and easy sizing. Impale the insulation on galvanized sheet steel safing clips, 24" (610 mm), and compression fit into the opening between the curtainwall insulation and floor slab. Leave no voids. Compress the insulation as needed into all penetrations in fire-rated floor slabs and partitions. Completely fill voids around various assembly penetrations. Butt ends and edges closely together and fill all voids with additional insulation.

Maintaining the integrity of the vapor retarder is critical for effective moisture/humidity control. Pressure-sensitive joint sealing tape should be used to cover all insulation joints. Pins, clips and any punctures or tears in the facing should be covered with vapor-sealing, pressure-sensitive patches to maintain the integrity of the vapor retarder. Follow tape manufacturer's application recommendations and instructions.

Product should not be exposed to weather during shipping, storage or installation. Follow the "Exposure Controls" and "Personal Protection" information in the Material Safety Data Sheet (MSDS) when handling this product.

Wear goggles or safety glasses with side shields while handling or installing MinWool-1200 Safing Insulation. This is especially important when installing insulation overhead. A loose-fitting, long-sleeve shirt and long pants are recommended to provide skin protection. Cover shirt cuffs with glove wrist bands. Wear a hat or cap to keep dust particles out of the hair and away from the scalp.

Government Certification

When ordering material to comply with any government specification or any other listed specification, a statement of that fact must appear on the purchase order. Government regulations and other listed specifications require specific lot testing, and prohibit the certification of compliance after shipment has been made. There may be additional charges associated with specification compliance testing. Please refer to price page IIG-CSP-3 for Certification Procedures and Charges. Call customer service for more information.

MinWool-1200 Safing

High Temperature Insulation

Specification Compliance

ASTM C 612 (HH-I-558B)	Types 1-4
Flame Spread/Smoke Developed, ASTM E 84 , UL 723, CAN/ULC-S102-M	Unfaced 5/0; Faced 25/5
ASTM E 136	Noncombustible
ASTM C 1338	Passes
Water Vapor Sorption, ASTM C 1104	<1% By Weight at 120°F (49°C), 95% RH
FSP Facing Permeability, ASTM E 96002 Perms, Maximum
City of New YorkMEA-346-90
ICBO (Uniform Building Code)	All Building Classification Types
BOCA (National Building Code)	All Building Classification Types
SBCCI (Standard Building Code)	All Building Classification Types
ICC (International Building Code)	All Building Classification Types

Density (pcf)	Density (kg/m ³)	R Value/in.(per 25 mm)		Width		Length		Thickness			
		(hr•ft ² •°F)/Btu	m ² •°C/W	(in.)	(mm)	(in.)	(mm)	Unfaced (in.)	Unfaced (mm)	Faced (in.)	Faced (mm)
4	64	4.0	0.70	24	610	48	1219	1-6	25-152	2-4	51-102

Thickness range available in 1/2" (13 mm) increments. Custom lengths, widths, and thicknesses are also available. R-Value determined in accordance with ASTM C 518. The higher the R-Value, the greater the insulating power.

Typical Perimeter Fire Containment Joint

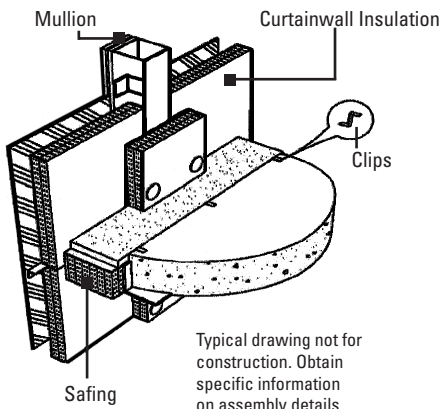

Industrial Insulation Group, LLC is a Calsilite/Johns Manville joint venture. IIG manufactures MinWool-1200 mineral fiber pipe, block and a variety of other insulations; Thermo-12® Gold Calcium Silicate pipe and block insulation; Super Firetemp® fireproofing board; Sproule WR-1200™ Perlite pipe and block insulation; high temperature adhesives, and insulating finishing cement.

**For Customer Service
and Order Placement**
(866) 444-4380
Fax: (866) 444-4766

**For Sales
Information**
(800) 866-3234
Fax: (866) 325-8180

**For Technical
Information**
(800) 872-0338
Fax: (866) 384-9338



IIG MinWool, LLC

A Calsilite/Johns Manville Joint Venture

908 John Bussey Drive
Phenix City, AL 36869
www.iig-llc.com

The physical and chemical properties of the MinWool-1200 Safing presented herein represent typical, average values obtained in accordance with accepted test methods and are subject to normal manufacturing variations. They are supplied as a technical service and are subject to change without notice. Numerical flame spread and smoke developed ratings are not intended to reflect hazards presented by these or any other materials under actual fire conditions. Check with the Customer Service Office to assure current information. **All Industrial Insulation Group products are sold subject to the IIG Limited Warranty and Limitation of Remedy. For a copy of the IIG Limited Warranty and Limitation of Remedy, email - info@iig-llc.com.**

The **GREENGUARD INDOOR AIR QUALITY CERTIFIED®** Mark is a registered certification mark used under license through the GREENGUARD Environmental Institute.