

ICC Evaluation Service, Inc.
www.icc-es.org

Business/Regional Office ■ 5360 Workman Mill Road, Whittier, California 90601 ■ (562) 699-0543
Regional Office ■ 900 Montclair Road, Suite A, Birmingham, Alabama 35213 ■ (205) 599-9800
Regional Office ■ 4051 West Flossmoor Road, Country Club Hills, Illinois 60478 ■ (708) 799-2305

DIVISION: 06—WOOD AND PLASTICS
Section: 06170—Prefabricated Structural Wood

REPORT HOLDER:

WEYERHAEUSER
POST OFFICE BOX 8449
BOISE, IDAHO 83707-2449
(208) 429-3715
www.iLevel.com
daniel.cheney2@weyerhaeuser.com

EVALUATION SUBJECT:

TJI® PREFABRICATED WOOD I-JOISTS

1.0 EVALUATION SCOPE

Compliance with the following codes:

- 2006 *International Building Code*® (IBC)
- 2006 *International Residential Code*® (IRC)
- 1997 *Uniform Building Code*™ (UBC)
- BOCA® *National Building Code/1999* (BNBC)
- 1999 *Standard Building Code*® (SBC)

Properties evaluated:

- Structural
- Sound ratings
- Fire-resistance ratings

2.0 USES

TJI joists are prefabricated wood I-joists used as floor joists, roof rafters, blocking panels and rim joists, to support code-required loads. Prefabricated wood I-joists described in this report comply with Section 2303.1.2 of the IBC, for allowable stress design; Section R502.1.4 of the IRC; Section 2313.5 of the BNBC; Section 2301.4.11 of the SBC; and Section 2303, Item 5.1, of the UBC.

3.0 DESCRIPTION

3.1 General:

TJI joists are prefabricated wood I-joists having wood or wood-based flanges and Performance Plus® oriented strand board (OSB) webs. Either the top and bottom flanges are parallel, forming a constant-depth joist; or the top flange has a single taper, forming a variable-depth joist. The web panels have the face grain oriented vertically, and the web-to-web connection is either butt jointed or serrated and glued to form a continuous web. The web-to-flange connection is a proprietary tongue-and-groove glued joint. Refer to Table 1 for TJI joist series and material descriptions.

3.2 Material Specifications:

3.2.1 Flanges: Flange material is either Microllam® laminated veneer lumber (LVL), TimberStrand® laminated strand lumber (LSL) or machine stress rated lumber (MSR). Microllam LVL and TimberStrand LSL are recognized in evaluation report ESR-1387. Table 1 of this report specifies flange widths and depths. Flange material and grades are as specified in the quality control manual that contains Weyerhaeuser manufacturing standards.

3.2.2 Webs: Web material is Performance Plus® OSB conforming to DOC Voluntary Product Standard PS2, Exposure 1, along with further requirements set forth in the quality control manual that contains Weyerhaeuser manufacturing standards. Web material thickness requirements are noted in Table 1 of this report.

3.2.3 Adhesives: Adhesives are of the types specified in the quality control manual that contains Weyerhaeuser manufacturing standards.

4.0 DESIGN AND INSTALLATION

4.1 General:

The design and installation of TJI joists described in this report must comply with Sections 4.2 through 4.16. Additionally, design of TJI joists is governed by the applicable code and corresponding editions of ANSI/AF&PA NDS, National Design Specification for Wood Construction (NDS).

4.2 Allowable Capacity:

Table 3 specifies allowable moments, reactions, vertical shear forces, and joist stiffness (EI). Maximum allowable reactions are based on minimum bearing lengths of $1\frac{3}{4}$ inches, $2\frac{1}{2}$ inches and $3\frac{1}{2}$ inches (45, 64 and 89 mm), for simple spans; and $3\frac{1}{2}$, $5\frac{1}{4}$ and 7 inches (89, 133 and 178 mm) at intermediate support points for continuous spans. When joists are used as multiple span members, the calculated shear, used for design at the intermediate support, may be reduced by the percentage determined from the following formula and limited to the depths shown in Table 4:

$$R = W \div K \leq 18\%$$

where:

$$K = V_{12} \div 100.$$

$$R = \text{The percent reduction.}$$

$$V_{12} = \text{The allowable shear for an } 11\frac{7}{8}\text{-inch-deep (302 mm) joist (pounds).}$$

$$W = \text{The uniform load (plf).}$$

The allowable design shear at the interior supports of multiple-span-member TJI joists up to 12 inches (305 mm) deep, used in residential floor construction, is permitted to be increased by 10 percent. This increase in allowable design shear does not apply to the design shear at the ends of the joists.

4.3 Fasteners:

Allowable lateral and withdrawal loads for fasteners, installed parallel or perpendicular to Microllam LVL or TimberStrand LSL flange glue lines, must comply with ESR-1387 and the applicable code. Allowable lateral loads and withdrawal loads for fasteners installed into TJI joist sawn lumber flanges must be designed using the applicable code and a specific gravity of 0.42, such as for spruce-pine-fir.

Allowable nail spacings for TJI joist diaphragm applications must be as specified in Sections 4.14 and 4.15, and Table 2.

For nondiaphragm applications:

1. The spacing of fasteners installed into the face grain of Microllam LVL or TimberStrand LSL flanges must be greater than or equal to the closest permitted on-center spacing prescribed by the code for fasteners installed in sawn lumber.
2. The spacing of fasteners installed into the edge grain of Microllam LVL or TimberStrand LSL flanges must be greater than or equal to the closest permitted on-center spacing requirements detailed in ESR-1387.
3. The spacing of fasteners installed into TJI joist sawn lumber flanges must be as prescribed by the code for fasteners installed in sawn lumber.

The allowable lateral load capacity of 10d by 1 $\frac{1}{2}$ -inch-long (38 mm) common nails used to connect minimum No. 18 gage [0.048 inch (1.2 mm) base-metal thickness] metal straps or tension-ties, recognized in a current ICC-ES evaluation report, to TJI joist flanges, in conformance with Figure 7 of this report, is 112 pounds-force (498 N) per nail. The connections with the structural composite lumber flanges may be used for out-of-plane wall anchorage to flexible diaphragms in lieu of the minimum 2 $\frac{1}{2}$ -inch (63.5 mm) wood element thickness specified in Item 5 of Section 1633.2.8.1 of the UBC.

4.4 Web Stiffeners:

Web stiffener requirements for reactions and concentrated loads are noted in Table 3 and Figure 1.

4.5 Lateral Support:

TJI joist compression flanges with widths less than 2.3 inches (58 mm) require lateral support every 18 inches (457 mm) on center. TJI joist compression flanges with widths equal to or greater than 2.3 inches (58 mm) require lateral support every 24 inches (610 mm) on center. Each connection must be capable of transmitting a 75-pound-force (334 N) horizontal load. All TJI joist ends require restraint to prevent rollover. Code prescribed methods of lateral restraint specified for sawn lumber are acceptable. Bridging is not required for floor and roof TJI joist applications.

4.6 Holes in TJI Joist Web:

The tables in Figures 2, 3 and 3A specify allowable sizes and location of round, square and rectangular holes in the TJI joist webs. TJI joists with holes located in the web in accordance with Figures 2, 3 and 3A are permitted to be used in the fire-resistive-rated Assemblies B, C, D, E and F described in Section 4.17, and Assembly G described in Section 4.18.

4.7 Duration of Load:

Adjustments for duration of load, in accordance with Part 2.3.2 of the NDS or Item 6 of Section 2316.2 of the UBC, apply to the TJI joists and their fastenings.

4.8 In-service Moisture Conditions:

TJI joist design values must be adjusted in accordance with Section 4.1.4 of the NDS when in-service moisture content exceeds 16 percent.

4.9 Repetitive-member Use:

The repetitive-member use factor applicable to the resistive moment capacities listed in Table 3 is limited to 1.0.

4.10 Member Spans:

TJI joist spans must be determined in accordance with Part 3.2.1 of the NDS. Vertical shear calculations must include all loads within the span from face to face of supports.

4.11 Deflection:

Deflection of simple span TJI joists with either uniform load or a concentrated load at midspan is determined using the formulas in the footnotes to Table 3.

4.12 Blocking Panels:

Bearing walls perpendicular to and supported by TJI joists at the end or intermediate supports, or both, require full-depth blocking. TJI joists up to and including 16 inches (406 mm) in depth, when used as blocking panels, have a maximum vertical load transfer capacity of 2,100 plf (30 645 N/m). TJI joists over 16 inches (406 mm) and up to and including 20 inches (508 mm) in depth, when used as blocking panels, have a maximum vertical load transfer capacity of 1,550 plf (22 620 N/m).

4.13 Rim Joists:

TJI joists having depths of up to and including 16 inches (406 mm) may be used as rim joists and boundary members of horizontal wood structural diaphragms. The joists have a maximum vertical load transfer capacity of 2,100 plf (30,645 N/m). TJI joists used as rim joists must be laterally supported at the top and continuously supported at the bottom, and the gravity loads must be uniformly applied along the top. Other loading and support conditions must be investigated and approved by a design professional.

4.14 TJI Joists as Prescriptive Diaphragm Framing Members:

TJI joists are permitted as framing members in prescriptive floor and roof diaphragm construction in accordance with Section 2308 of the IBC, Chapters 5 and 8 of the IRC, or Section 2320 of the UBC. When TJI 110, TJI 210 or TJI 230 series I-joists are used in floor diaphragm construction, the thickness of the sheathing must be $\frac{19}{32}$ inch (15.1 mm) or greater.

4.15 TJI Joists as Engineered Diaphragm Framing Members:

TJI 110, TJI 210, TJI 230, TJI 360, TJI 560, TJI 100C and TJI 300C joists may be used as framing members in blocked and unblocked engineered diaphragms designed using Table 2306.3.1 of the IBC, or Table 23-II-H of the UBC, subject to the limitations specified in Table 2 of this report.

TJI L65, TJI L90, TJI H90, TJI HD90 and TJI HS90 joists may be used as framing members in diaphragms designed in accordance with the applicable code. The closest permitted sheathing nail spacing in a single row is 3 inches (76 mm) on center for 10d common nails or 2 inches (51 mm) on center for 8d common nails.

4.16 Cantilevered TJI Joists:

TJI joists are permitted to be installed with cantilevered ends, provided the cantilevers have a maximum length equal to one-third of the adjacent span and support uniform loads only, unless designed by a design professional.

4.17 One-hour Fire-resistance-rated Roof-ceiling or Floor-ceiling Assemblies:

Refer to Figure 4 for details. For assemblies A, B, C, D, E and F, used as floor ceiling assemblies over unusable crawl spaces, it is permitted to omit the ceiling membrane. Additionally, flooring is permitted to be omitted where unusable attic space occurs above, provided the lateral support requirements of Section 4.5 are met. The assemblies must be constructed as follows:

4.17.1 Assembly A:

1. A double wood floor consisting of a subfloor of nominal 1-inch-thick (25.4 mm), tongue-and-groove sheathing or 32/16 span-rated sheathing (Exposure 1); and a second layer of nominal 1-inch-thick (25.4 mm), tongue-and-groove finish flooring. Alternatively, the finish flooring is permitted to be 40/20 span-rated sheathing (Exposure 1), or Type I, Grade —1, particleboard not less than $\frac{5}{8}$ inch (15.9 mm) thick.

All butt joints of the sheathing must be located over framing members.

When used as a roof-ceiling assembly, a single layer of square-edge span-rated sheathing (Exposure 1), complying with the code, is permitted to be used for roof sheathing.

2. TJI joists with a minimum flange depth of $1\frac{1}{2}$ inches (38 mm) must be installed in accordance with this report at a maximum spacing of 48 inches (1219 mm) on center.
3. The suspended ceiling must consist of $\frac{5}{8}$ -inch-thick (15.9 mm), 2-foot-by-2-foot (610 mm by 610 mm) or 2-foot-by-4-foot (610 mm by 1219 mm), USG FIRECODE AURATONE lay-in acoustical board supported by an approved, exposed fire-resistance-rated suspension system attached to the joist bottom flange or to cold-rolled channels spaced not more than 48 inches (1219 mm) on center. When TJI joists are spaced more than 24 inches (610 mm) on center, framing perpendicular to the joists must be installed at 24 inches (610 mm) on center to support the ceiling. The distance from the bottom of the TJI joists to the soffit of the ceiling must be a minimum of 10 inches (254 mm).
4. Installed over the acoustical board are minimum 1-inch-thick (25.4 mm), 4 pcf (64 kg/m³), Thermafiber® Sound Attenuation Fire Blankets, Fibrex®-FBX 1240 Industrial Boards, Fibrex®-IF 1240 Flex Batts, IIG MinWool®-1240 Industrial Board or IIG MinWool®-1240 Flexible Batt.
5. Light fixtures having a maximum size of 2 feet by 4 feet (610 mm by 1219 mm) are permitted to be installed in the ceiling, provided the aggregate area of fixtures does not exceed 12 square feet per 100 square feet (1.1 m² per 9.3 m²) of ceiling area and the fixtures are protected as follows [using, for illustration, a 2-foot-by-4-foot (610 mm by 1219 mm) fixture]: A $2\frac{1}{4}$ -inch-by-48-inch (57 mm by 1219 mm), minimum $1\frac{1}{4}$ -inch-thick (31.8 mm) piece of minimum 4 pcf (64 kg/m³) Thermafiber rigid mineral fiber board or Fibrex-FBX 1240 Industrial Board or Fibrex-IF 1240 Flex Batt light fixture protection, is laid along the long sides of the fixture, and against adjacent suspension members; two pieces of the same insulation, measuring $19\frac{1}{2}$ inches by 48 inches (495 mm by 1219 mm), are laid over the top of the fixture, and a $4\frac{1}{2}$ -inch-by-24-inch (114 mm by 610 mm) piece of the same insulation is laid at each end and tied at the corners of the fixture, to the top pieces using No. 18 SWG steel wire. See Figure 6 for details. In addition, ceiling openings for air diffusers, up to a maximum of 12 inches (305 mm) in diameter, are permitted, provided openings

are protected with approved fire dampers and the aggregate areas do not exceed 113 square inches (72 900 mm²) per 100 square feet (9.3 m²) of ceiling area.

4.17.2 Assembly B:

1. The flooring must consist of a single layer of 48/24 span-rated, tongue-and-groove, sheathing (Exposure 1). Construction adhesive conforming to ASTM D 3498 must be applied to the top of the joists prior to placing sheathing. When used as a roof-ceiling assembly, the decking is permitted to be any wood deck recognized in the code. All butt joints of the sheathing must be located over framing members.
2. TJI joists must be installed in accordance with this report, with a maximum spacing of 24 inches (610 mm) on center for floor-ceiling assemblies. When used in roof-ceiling assemblies, the joists are permitted to be spaced a maximum of 48 inches (1219 mm) on center.
3. Optional minimum $3\frac{1}{2}$ -inch-thick (89 mm) glass fiber insulation or glass fiber insulation rated R-30 or less may be installed in the joist plenum when resilient channels are used. The insulation must be placed above the resilient channels between the joist bottom flanges.
4. The ceiling membrane must consist of two layers of $\frac{1}{2}$ -inch-thick (12.7 mm), Type C, or $\frac{5}{8}$ -inch-thick (15.9 mm), Type X gypsum board complying with ASTM C 36, attached to the TJI joist bottom flange.
5. The first layer of gypsum board must be installed perpendicular to the TJI joists and attached using $1\frac{5}{8}$ -inch-long (41 mm), Type S screws spaced 12 inches (305 mm) on center. The second layer must be installed with the joints staggered from the first layer. The second layer must be fastened to the TJI joists with 2-inch-long (51 mm), Type S screws spaced 12 inches (305 mm) on center in the field and 8 inches (203 mm) on center at the butt joints.

Type G screws, $1\frac{1}{2}$ inches (38 mm) long, must be spaced 8 inches (203 mm) on center and 6 inches (152 mm) from each side of the transverse joints of the second layer. The second layer must be finished with joint tape and compound.
6. Resilient channels (RC-1) are permitted to be used as part of the ceiling attachment system, provided they are spaced 16 inches (406 mm) on center [24 inches (610 mm) on center if the joists are spaced 16 inches (406 mm) on center] and fastened perpendicular to the TJI joists using 1-inch-long (25.4 mm), Type S screws. When resilient channels are used, the first layer of the ceiling membrane must be installed perpendicular to the channels and attached to the resilient channels using 1-inch-long (25.4 mm), Type S screws spaced 12 inches (305 mm) on center. The second layer must be installed with the joints staggered from the first layer and attached using $1\frac{5}{8}$ -inch-long (41 mm), Type S screws. The screw spacing for the second layer of gypsum board must be a maximum of 12 inches (305 mm) on center in the field and 8 inches (203 mm) on center at the butt joints.

Type G screws, $1\frac{1}{2}$ inches (38 mm) long, must be spaced 8 inches (203 mm) on center and 6 inches (152 mm) from each side of the transverse joints of the second layer. The second layer must be finished with joint tape and compound.

7. In roof-ceiling assemblies in which the TJI joists are spaced more than 24 inches (610 mm) on center, the ceiling, including the resilient channels, must be applied to stripping spaced 24 inches (610 mm) on center. The

attachment of the ceiling membrane to the stripping members must be similar to the attachment of the ceiling membrane to the TJI joists. The stripping must be a minimum of nominal 2-by-4 construction-grade Douglas fir lumber for spans up to 5 feet (1524 mm), and must be attached to the joist bottom flange using a minimum of two 10d box nails. Stripping materials of equivalent strength and attachment are permitted when approved by the code official.

4.17.3 Assembly C:

1. The flooring must consist of a single layer of 48/24 span-rated, tongue-and-groove sheathing (Exposure 1). Construction adhesive conforming to ASTM D 3498 must be applied to the top of the joists prior to placing sheathing. When used as a roof-ceiling assembly, a single layer of square-edge span-rated sheathing (Exposure 1), complying with the code, is permitted to be used for roof sheathing. All butt joints of the sheathing must be located over framing members.
2. TJI joists must be installed in accordance with this report, with a maximum spacing of 24 inches (610 mm) on center for floor-ceiling assemblies. When used in roof-ceiling assemblies the joists are permitted to be spaced a maximum of 48 inches (1219 mm) on center. When the joist spacing exceeds 24 inches (610 mm) on center, framing perpendicular to the joists must be installed at 24 inches (610 mm) on center to support the ceiling.
3. The ceiling membrane must be installed perpendicular to the TJI joists or stripping, and must consist of a single layer of $\frac{1}{2}$ -inch-thick (12.7 mm), Type C, or $\frac{5}{8}$ -inch-thick (15.9 mm), Type X gypsum board complying with ASTM C 36, and attached to the joists, or to stripping spaced 24 inches (610 mm) on center. The gypsum board must be fastened using $1\frac{5}{8}$ -inch-long (41 mm), Type S screws located 6 inches (152 mm) on center at end joints and 8 inches (203 mm) on center in the field.
4. An approved, exposed, fire-resistance-rated, suspended-ceiling system must be installed beneath the gypsum board ceiling membrane. The minimum distance between the suspended ceiling and the gypsum board ceiling membrane must be 12 inches (305 mm). The grid system must be suspended with No. 12 SWG galvanized steel wire fastened to the stripping or joists using 3 inch (76 mm) long flathead hanger screws. Light fixture protection must consist of 6-inch-wide (152 mm) pieces of ceiling grid panels that are 48 inches (1219 mm) long for the sides, and 24 inches (610 mm) long for the ends, with a full grid panel placed on top.

A galvanized steel duct is permitted for each 200 square feet (18.6 m²) of ceiling, provided the duct has a maximum 12-inch-diameter (305 mm) steel diffuser opening without a damper, and a maximum 6-inch-by-12-inch (152 mm by 305 mm) return air opening. Ceiling panels must be $\frac{5}{8}$ inch (15.9 mm) thick, USG FIRECODE AURATONE. Glass fiber batt insulation rated R-30 or less is permitted to be installed above the gypsum board, in the cavity between the joists.

4.17.4 Assembly D:

1. The flooring must consist of a single layer of 48/24 span rated, tongue-and-groove sheathing (Exposure 1). When used as a roof-ceiling assembly, a single layer of square-edge, span-rated sheathing (Exposure 1), complying with the code, is permitted to be used for roof sheathing. All butt joints of the sheathing must be located over framing members.

2. The TJI joists must have a minimum flange depth of $1\frac{3}{8}$ inches (35 mm), and be installed in accordance with this report, with a maximum spacing of 24 inches (610 mm) on center.
3. The ceiling membrane must consist of a single layer of $\frac{1}{2}$ -inch-thick (12.7 mm) USG FIRECODE® Type C gypsum board or ProRoc® Type C gypsum board screw-attached to steel furring channels placed perpendicular to the joists. The furring channels must be spaced 24 inches (610 mm) on center and are attached and suspended from the joists using No. 24 gage proprietary attachment clips designated "Simpson Strong-Tie CSC Support Clips." A CSC support clip must be located at each joist, to support the furring channel. At channel splices, adjacent pieces are overlapped a minimum of 6 inches (152 mm), and are tied with double-strand No. 18 SWG galvanized steel wire at each end of the overlap.
4. A layer of 1-inch-thick (25.4 mm), minimum 6 pcf (96 kg/m³), Thermafiber Type CW 90 mineral-wool blanket, Fibrex-FBX 1280 Industrial Board, Fibrex-IF 1280 Flex Batt, IIG MinWool 1260 Industrial Board or IIG MinWool 1260 Flexible Batt must be placed below the bottom flanges of the joists and on top of the furring channels. Alternatively, a layer of 2-inch-thick (51 mm), Thermafiber mineral-wool blanket, having a density of 8 pcf (128 kg/m³), is permitted to be used.

4.17.5 Assembly E:

1. The flooring must consist of a double wood floor as described in Section 4.17.1, Assembly A, or a single layer of 48/24 span-rated, tongue-and-groove sheathing (Exposure 1). When a single-layer floor is used, a construction adhesive conforming to ASTM D 3498 must be applied to the top of the joists prior to placing sheathing. When joists are used in a roof-ceiling assembly, a single layer of square-edge, span-rated sheathing (Exposure 1), complying with the code is permitted to be used for roof sheathing. All butt joints of the sheathing must be located over framing members.
2. TJI joists must be installed in accordance with this report, with a maximum spacing of 24 inches (610 mm) on center for floor-ceiling assemblies, and a maximum spacing of 48 inches (1219 mm) on center for roof-ceiling assemblies. When the flooring consists of a double wood floor as described in Section 4.17.1 (Assembly A), the joists may be spaced a maximum of 48 inches (1219 mm) on center.

When TJI joists are spaced more than 24 inches (610 mm) on center, the ceiling, including the resilient channels, must be applied to stripping spaced 24 inches (610 mm) on center. The attachment of the ceiling membrane to the stripping must be similar to the attachment of the ceiling membrane to the TJI joists. The stripping must be a minimum of nominal 2-by-4, construction-grade Douglas fir lumber for spans up to 5 feet (1524 mm), and must be attached to the joist bottom flange using a minimum of two 10d box nails. Stripping materials of equivalent strength and attachment are permitted when specifically approved by the code official.

3. Any approved ceiling membrane that provides a minimum 40-minute finish rating must be used. An example of an approved ceiling having a 40-minute finish rating is one that consists of two layers of $\frac{1}{2}$ -inch-thick (12.7 mm), Type X gypsum board complying with ASTM C 36, a minimum of 4 feet (1219 mm) wide, installed perpendicular to the TJI joists, as described in Section 4.17.2 of this report (Assembly B). Substantiating data, including a report of the fire-endurance testing conducted in accordance with

UBC Standard 7-1 or ASTM E 119, must be furnished to the local code official, and must verify that a particular ceiling system meets the 40-minute finish rating requirements.

When the finish rating is to be determined, temperature performance of protective membranes must be in accordance with Section 47 of ASTM E 119 or Section 7.144 of UBC Standard 7-1. The finish rating is defined in Section 48 of ASTM E 119 or Section 7.145 of UBC Standard 7-1.

4.17.6 Assembly F:

1. The flooring must consist of a single layer of 48/24 span-rated, tongue-and-groove sheathing (Exposure 1). The flooring must be attached to the TJI joist top flange with AFG-01 construction adhesive, and nailed using 8d common nails spaced a maximum of 6 inches (152 mm) on center along the boundary and edges and 12 inches (305 mm) on center in the field.

When used as a roof-ceiling assembly, a single layer of square-edge, span-rated sheathing (Exposure 1), complying with the code is permitted to be used for roof sheathing.

All butt joints of the floor or roof sheathing must be located over framing members.

2. TJI joists must have nominal 2-by-4 or larger flanges, and must be installed in accordance with this report. When used in a floor-ceiling assembly, the joist spacing must not exceed 24 inches (610 mm) on center. When used in a roof-ceiling assembly, the TJI joist spacing is permitted to exceed 24 inches (610 mm) on center.
3. The ceiling membrane must consist of one layer of $\frac{5}{8}$ -inch-thick (15.9 mm), USG FIRECODE Type C gypsum board or ProRoc Type C gypsum board, screw-attached to RC-1 resilient channels spaced 16 inches (406 mm) on center, placed perpendicular to the TJI joists. The resilient channels must be attached with $1\frac{5}{8}$ -inch-long (41.3 mm), Type S screws at each joist. Two channels must be provided at each gypsum board butt joint, and extend to the next joist beyond the longitudinal joints. The gypsum board must be fastened to the resilient channels with 1-inch-long (25.4 mm), Type S screws spaced 12 inches (305 mm) on center in the field and 8 inches (203 mm) on center at the butt joints.
4. In roof ceiling assemblies in which TJI joists are spaced more than 24 inches (610 mm) on center, the ceiling, including the resilient channels, must be attached to stripping spaced 24 inches (610 mm) on center. The attachment of the ceiling membrane to the stripping members is similar to the attachment of the ceiling membrane to the joists. For spans up to 5 feet (1524 mm), the stripping members must be minimum nominal 2-by-4, construction-grade Douglas fir lumber. The stripping must be attached to the bottom flanges of the joists using a minimum of two 10d box nails. Stripping materials of equivalent strength and attachment are permitted when specifically approved by the code official.
5. A layer of $1\frac{1}{2}$ -inch-thick (38 mm), minimum $2\frac{1}{2}$ pcf (40 kg/m³), Thermafiber Sound Attenuation Fire Blankets, Fibrex-SAFB (Sound Attenuation Fire Batts), or IIG MinWool-1200 Sound Attenuation Fire Batts, must be placed between the bottom flanges of the joists on the top of the resilient channels. The insulation material must be friction-fitted into place and supported by the resilient channels.

4.18 Assembly G: Two-hour Fire-resistance-rated Roof-ceiling or Floor-ceiling Assembly:

See Figure 5 for details. When used as a floor-ceiling assembly over unusable crawl spaces, the ceiling membrane is permitted to be omitted. Additionally, flooring is permitted to be omitted where unusable attic space occurs above the following system, provided the requirements of Section 4.5 are met. The assembly must be constructed as follows:

1. The floor sheathing must consist of a single layer of 48/24 span-rated, tongue-and-groove sheathing (Exposure 1). All butt joints of the floor or roof sheathing must be located over framing members.

When TJI joists are used in a roof-ceiling assembly, a single layer of square-edge, span-rated sheathing (Exposure 1), complying with the code, is permitted to be used as roof sheathing.

2. TJI joists must be installed in accordance with this report, with a maximum spacing of 24 inches (610 mm) on center. Minimum TJI joist depth is $9\frac{1}{4}$ inches (235 mm).
3. (Optional.) When insulation is used, it must consist of glass-fiber insulation with unfaced batts that are 24 inches (610 mm) wide by 48 inches (1219 mm) long by $3\frac{1}{2}$ inches (89 mm) thick. The insulation must be placed in the plenum and supported by stay wires spaced at 12 inches (305 mm) along the joist bottom flange.
4. The ceiling membrane must consist of three layers of $\frac{5}{8}$ -inch-thick (15.9 mm) Gold Bond Fire Shield C, Type X, gypsum board. The base layer must be applied perpendicular to the joists, with end joints staggered, and must be attached directly to the bottom flange using $1\frac{5}{8}$ -inch-long (41 mm), Type S screws spaced 12 inches (305 mm) on center along each joist. Resilient channels, minimum No. 28 gage [0.016-inch (0.41 mm)], must be applied under the first layer of gypsum board, perpendicular to the joists and spaced a maximum of 16 inches (406 mm) on center. The channels must be attached to the bottom flange of each joist, respectively, with $1\frac{5}{8}$ -inch-long (41 mm), Type S screws. The middle layer of gypsum board must be installed perpendicular to the resilient channels, with end joints staggered, and attached to the resilient channels with 1-inch-long (25.4 mm), Type S screws spaced 12 inches (305 mm) on center. The finish layer of gypsum board must be installed with edges and end joints staggered from the middle layer, and must be fastened to the resilient channels using $1\frac{5}{8}$ -inch-long (41 mm), Type S screws spaced 8 inches (203 mm) on center. Joints of the finish layer of gypsum board must be covered with joint compound and paper tape, and exposed screw heads must be covered with joint compound.

4.19 Alternate Floor or Roof Systems:

An alternate floor or roof deck to Assemblies A, B, C, D, E and F, described in Sections 4.17.1 through 4.17.6, and to the two-hour assembly described in Section 4.18, consists of minimum 48/24 span-rated sheathing (Exposure 1), over TJI joists spaced a maximum of 24 inches (610 mm) on center, with either $1\frac{1}{2}$ -inch-thick (38 mm) lightweight concrete or $\frac{3}{4}$ -inch-thick (19.1 mm) gypsum concrete over the sheathing. When the TJI joists are limited to a maximum spacing of 20 inches (508 mm) on center, a minimum 40/20 span-rated sheathing is permitted to be used. The gypsum concrete must be recognized in a current ICC-ES evaluation report, and the report must include an evaluation for fire resistance that permits the replacement of the floor systems with the sheathing and gypsum concrete system.

4.20 Sound Ratings:

4.20.1 Assembly B, Option 1, STC = 50: Assembly B (described in Section 4.17.2 and shown in Figure 4) has a minimum sound transmission class (STC) rating of 50 when constructed with resilient channels spaced at 16 inches (406 mm) on center to separate the ceiling membrane from the structural framing. This assembly has the following minimum impact insulation class (IIC) ratings when constructed with the corresponding additional materials described below.

1. IIC Rating of 60: The floor covering must include a 40-ounce-per-square-yard (1.36 kg/m²) pad and a 56-ounce-per-square-yard (1.90 kg/m²) carpet.
2. IIC Rating of 51: The floor covering must consist of Tarkett Acoustiflor sheet vinyl, the ceiling must consist of two layers of ⁵/₈-inch-thick (15.9 mm), Type X gypsum board, and the bottom of the floor cavity must contain 3¹/₂-inch-thick (89 mm) glass-fiber insulation.
3. IIC rating of 45: The floor covering must include a 43.2-ounce-per-square-yard (1.47/kg/m²), minimum 0.123-inch-thick (3.1 mm) cushioned vinyl.

4.20.2 Assembly B, Option 2, STC = 58: Assembly B (described in Section 4.17.2 and shown in Figure 4) has a minimum STC rating of 58 when constructed with resilient channels spaced at 16 inches (406 mm) on center to separate the ceiling membrane from the structural framing, and with a ³/₄-inch-thick (19.1 mm) floor topping of gypsum concrete recognized in a current evaluation report. This assembly has the following IIC ratings when constructed with the additional materials described below.

1. IIC Rating of 54: The floor covering must include a 40-ounce-per-square-yard (1.36 kg/m²) pad and a 56-ounce-per-square-yard (1.90 kg/m²) carpet.
2. IIC Rating of 54: The floor covering must consist of Tarkett Acoustiflor sheet vinyl, the ceiling must consist of two layers of ⁵/₈-inch-thick (15.9 mm), Type X gypsum board, and the bottom of the floor cavity must contain 3¹/₂-inch-thick (89 mm) glass fiber insulation.
3. IIC Rating of 50: The floor covering must be either Armstrong VIOS or Armstrong Cambray sheet vinyl, the ceiling must consist of two layers of ⁵/₈-inch-thick (15.9 mm) Type X gypsum board, and the bottom of the floor cavity must contain 3¹/₂-inch-thick (89 mm) glass fiber insulation.

4.20.3 Assembly D, Option 1, STC = 47, IIC = 54: Assembly D (described in Section 4.17.4 and shown in Figure 4) has an STC rating of 47. This assembly has an IIC rating of 54, when the floor covering includes a 40-ounce-per-square-yard (1.36 kg/m²) pad and a 56-ounce-per-square-yard (1.90 kg/m²) carpet.

4.20.4 Assembly D, Option 2, STC = 59, IIC = 54: Assembly D (described in Section 4.17.4 and shown in Figure 4) has an STC rating of 59 when the assembly is constructed with a ³/₄-inch-thick (19.1 mm) topping of gypsum concrete recognized in a current evaluation report. This assembly has an IIC rating of 54, when the floor covering includes a 40-ounce-per-square-yard (1.36 kg/m²) pad and a 56-ounce-per-square-yard (1.90 kg/m²) carpet.

5.0 CONDITIONS OF USE

The TJI Prefabricated Wood I-joists described in this report comply with or are suitable alternatives to joists and rafters specified in the codes specifically listed in Section 1.0, subject to the following conditions:

- 5.1 TJI joists are designed in accordance with this report.
- 5.2 Drawings and design details verifying compliance with this report are submitted to the code official for approval.
- 5.3 Allowable design properties for TJI joists and their fasteners are permitted to be increased for duration of load in accordance with the applicable code.
- 5.4 Where one-hour or two-hour fire-resistance-rated construction is required, construction complies with this report.
- 5.5 No cutting or notching of TJI joist flanges is permitted.
- 5.6 Sound rated assemblies noted in Sections 4.20.1 and 4.20.3 and Figure 4, with STC and/or IIC ratings of less than 50, are only applicable in jurisdictions using the IRC, BNBC or SBC.
- 5.7 TJI joists are produced at the Weyerhaeuser plants located in Castleberry, Alabama; Claresholm, Alberta, Canada; Chavies, Kentucky; Eugene Oregon; Natchitoches, Louisiana; Stayton, Oregon; and Valdosta, Georgia; under a quality control program with inspections by PFS Corporation (AA-652).

6.0 EVIDENCE SUBMITTED

- 6.1 Data in accordance with the ICC-ES Acceptance Criteria for Prefabricated Wood I-joists (AC14), dated June 2004.
- 6.2 Reports of fire tests conducted in accordance with ASTM E 119.
- 6.3 Reports of sound transmission tests conducted in accordance with ASTM E 90, E 413 and E 492.

7.0 IDENTIFICATION

TJI prefabricated wood I-joists are identified by a stamp that includes the product designation, evaluation report number (ICC-ES ESR-1153), manufacturer's name (Weyerhaeuser) or logo, plant number, production date, and the name or logo of the inspection agency (PFS Corporation).

TABLE 1—TJI® JOIST DESCRIPTION

TJI JOIST SERIES	FLANGE SIZE, DEPTH × WIDTH (inches)	WEB THICKNESS (inches)	RANGE OF JOIST DEPTHS (inches)
TJI® 110	1.25 to 1.375 × 1.75	$\frac{3}{8}$	$9\frac{1}{2}$ - 14
TJI® 210	1.25 to 1.375 × 2.08	$\frac{3}{8}$	$9\frac{1}{2}$ - 16
TJI® 230	1.25 to 1.375 × 2.3	$\frac{3}{8}$	$9\frac{1}{2}$ - 16
TJI® 360	1.375 × 2.3	$\frac{3}{8}$	$9\frac{1}{2}$ - 20
TJI® 560	1.375 × 3.5	$\frac{7}{16}$	$9\frac{1}{2}$ - 20
TJI® L65	1.5 × 2.5	$\frac{7}{16}$	$9\frac{1}{2}$ - 30 ($9\frac{1}{2}$ - 30 taper)
TJI® L90	1.5 × 3.5	$\frac{7}{16}$	$11\frac{7}{8}$ - 30 ($9\frac{1}{2}$ - 30 taper)
TJI® H90	1.75 × 3.5	$\frac{7}{16}$	$11\frac{7}{8}$ - 30
TJI® HD90	2.125 × 3.5	$\frac{1}{2}$	$11\frac{7}{8}$ - 32
TJI® HS90	2.5 × 3.5	$\frac{1}{2}$	$11\frac{7}{8}$ - 32
TJI® 100C	1.5 × 2.5	$\frac{3}{8}$	$9\frac{1}{2}$ - 16
TJI® 300C	1.5 × 2.5	$\frac{3}{8}$	$11\frac{7}{8}$ - 16

For SI: 1 inch = 25.4 mm.

TABLE 2 – TJI® JOIST ENGINEERED DIAPHRAGM FRAMING DESIGN INFORMATION ¹

TJI JOIST SERIES	EQUIVALENT NOMINAL FRAMING WIDTH	EQUIVALENT SPECIFIC GRAVITY	CLOSEST PERMITTED NAIL SPACING (inches) ²			MAXIMUM PERMITTED DESIGN CAPACITY (plf)
			6d common	8d common	10d common	
TJI 110 TJI 210	2 in.	0.50	4	4	4	425 ³
TJI 230	3 in.	0.50	4	4	4	480 ³
TJI 360 TJI 560	3 in.	0.50	3	3	4	720
TJI 100C TJI 300C	3 in.	0.42	3	3	4	660

For SI: 1 inch = 25.4 mm, 1 plf = 14.59 N/m.

- Allowable shear loads for wood structural panel diaphragms with TJI joist framing must be determined in accordance with Table 2306.3.1 of the IBC or Table 23-II-H of the UBC, using the equivalent nominal framing width and specific gravities specified in Table 2, and must not exceed the maximum permitted design capacity given.
- One row of nails is permitted along each sheathing panel end and edge. When nail spacing is less than 6 inches on center, adjacent nails within a row must be offset (staggered). The closest permitted nail spacing in Table 2 must not be exceeded. Solid sawn framing members must be used in lieu of TJI joist framing members where the fastener spacing required in IBC Table 2306.3.1 or UBC Table 23-II-H is closer than the closest permitted nail spacing given in Table 2 of this report.
- The design capacity of an unblocked diaphragm framed with TJI 110, TJI 210 or TJI 230 joists must be multiplied by a factor of 0.85 unless a non-polyurethane sub-floor adhesive is used in combination with mechanical fasteners for sheathing attachment. Continuous special inspection is not required for this adhesive application.

TABLE 3—PROPERTIES FOR TJI JOISTS

BASIC PROPERTIES						REACTION PROPERTIES									
Joist Depth (in.)	Joist Weight (plf)	Resistive Moment (ft.-lbs.) (10)	Vert. Shear (lbs.)	EI x 10 ⁶ bs.-in. ²	K	END REACTION (lbs.)					INTERMEDIATE REACTION (lbs.)				
						1-3/4"		3-1/2"		Nails Req'd for Web Stiff.	3-1/2"		5-1/4"		Nails Req'd for Web Stiff.
						2-1/2" (9)		Bearing Length			5-1/4" (7)		7" (7)		
						Bearing Length		Web Stiffeners			Bearing Length		Web Stiffeners		
NO		YES		NO		YES		NO		YES					
TJI 110															
9-1/2	2.3	2380	1220	140	4.5	885	NA	1220	NA	NA	1935	NA	2350	NA	NA
11-7/8	2.5	3015	1560	238	4.5	885	1225	1350	1560	3-8d	1935	2295	2350	2705	3-8d
14	2.8	3565	1860	351	4.5	885	1225	1350	1705	3-8d	1935	2295	2350	2705	3-8d
TJI 210															
9-1/2	2.6	2860	1330	167	4.5	980	NA	1330	NA	NA	2145	NA	2565	NA	NA
11-7/8	2.8	3620	1655	283	4.5	980	1340	1435	1655	3-8d	2145	2505	2565	2925	3-8d
14	3.1	4280	1945	415	4.5	980	1340	1435	1790	3-8d	2145	2505	2565	2925	3-8d
16	3.3	4895	2190	566	4.5	980	1340	1435	1790	3-8d	2145	2505	2565	2925	3-8d
TJI 230															
9-1/2	2.7	3175	1330	183	4.5	1035	NA	1330	NA	NA	2410	NA	2790	NA	NA
11-7/8	3.0	4015	1655	310	4.5	1035	1395	1460	1655	3-8d	2410	2765	2790	3150	3-8d
14	3.3	4755	1945	454	4.5	1035	1395	1460	1815	3-8d	2410	2765	2790	3150	3-8d
16	3.5	5440	2190	618	4.5	1035	1395	1460	1815	3-8d	2410	2765	2790	3150	3-8d
TJI 360															
9-1/2	2.7	4790	1425	249	4.5	1080	NA	1425	NA	NA	2460	NA	3000	NA	NA
11-7/8	3.0	6180	1705	419	4.5	1080	1440	1505	1705	3-8d	2460	2815	3000	3360	3-8d
14	3.3	7335	1955	612	4.5	1080	1440	1505	1865	3-8d	2460	2815	3000	3360	3-8d
16	3.5	8405	2190	830	4.5	1080	1440	1505	1865	3-8d	2460	2815	3000	3360	3-8d
18	3.7	9465	2425	1085	4.5	1080	1440	1505	1865	3-8d	2460	2815	3000	3360	3-8d
20	4.0	10515	2660	1376	4.5	1080	1440	1505	1865	3-8d	2460	2815	3000	3360	3-8d
TJI 560															
9-1/2	3.6	7355	1670	378	5.3	1265	NA	1670	NA	NA	3000	NA	3455	NA	NA
11-7/8	4.0	9500	2050	636	5.3	1265	1740	1725	2050	3-16d	3000	3475	3455	3930	3-16d
14	4.2	11275	2390	926	5.3	1265	1740	1725	2200	3-16d	3000	3475	3455	3930	3-16d
16	4.5	12925	2710	1252	5.3	1265	1740	1725	2200	3-16d	3000	3475	3455	3930	3-16d
18	4.8	14550	3030	1631	5.3	1265	1740	1725	2200	3-16d	3000	3475	3455	3930	3-16d
20	5.1	16165	3345	2064	5.3	1265	1740	1725	2200	3-16d	3000	3475	3455	3930	3-16d
TJI L65															
9-1/2	3.0	5215	1675	263	5.3	1375	NA	1675	NA	NA	2745	NA	3365	NA	NA
11-7/8	3.3	6750	1925	450	5.3	1375	1745	1885	1925	3-8d	2745	3120	3365	3735	3-8d
14	3.6	8030	2125	666	5.3	1375	1750	1885	2125	5-8d	2745	3365	3365	3985	5-8d
16	3.9	9210	2330	913	5.3	1375	1750	1885	2330	6-8d	2745	3490	3365	4105	6-8d
18	4.2	10380	2535	1205	5.3	1375	1750	1885	2535	7-8d	2745	3615	3365	4230	7-8d
20	4.4	11540	2740	1545	5.3	NA	1750	NA	2740	8-8d	NA	3740	NA	4355	8-8d
22	4.7	12690	2935	1934	5.3	NA	1750	NA	2935	9-8d	NA	3860	NA	4480	9-8d
24	5.0	13830	3060	2374	5.3	NA	1750	NA	3060	10-8d	NA	3875	NA	4605	10-8d
26	5.3	14960	2900	2868	5.3	NA	1750	NA	2900	11-8d	NA	4725(7)	NA	5345(7)	11-8d
28	5.5	16085	2900	3417	5.3	NA	1750	NA	2900	12-8d	NA	4850(7)	NA	5470(7)	12-8d
30	5.8	17205	2900	4025	5.3	NA	1750	NA	2900	13-8d	NA	4975(7)	NA	5590(7)	13-8d

See notes at the end of the table.

TABLE 3—CONTINUED

BASIC PROPERTIES						REACTION PROPERTIES									
Joist Depth (in.)	Joist Weight (plf)	Resistive Moment (ft.-lbs.) (10)	Vert. Shear (lbs.)	EI x 10 ⁶ lbs.-in. ²	K	END REACTION (lbs.)					INTERMEDIATE REACTION (lbs.)				
						1-3/4" 2-1/2" (9)		3-1/2"		Nails Req'd for Web Stiff.	3-1/2" 5-1/4" (7)		5-1/4" 7" (7)		Nails Req'd for Web Stiff.
						Bearing Length		Bearing Length			Bearing Length		Bearing Length		
						Web Stiffeners		Web Stiffeners			Web Stiffeners		Web Stiffeners		
NO	YES	NO	YES	NO	YES	NO	YES	NO	YES						
TJI L90															
9 1/2	3.8	7415	1675	365	5.3	1400	NA	1675	NA	NA	3350	NA	3965	NA	NA
11-7/8	4.2	9605	1925	621	5.3	1400	1715	1885	1925	2-16d	3350	3665	3965	4285	2-16d
14	4.5	11430	2125	913	5.3	1400	1875	1885	2125	3-16d	3350	3825	3965	4440	3-16d
16	4.7	13115	2330	1246	5.3	1400	2030	1885	2330	4-16d	3350	3980	3965	4600	4-16d
18	5.0	14785	2535	1635	5.3	1400	2030	1885	2515	4-16d	3350	3980	3965	4600	4-16d
20	5.3	16435	2740	2085	5.3	NA	2190	NA	2675	5-16d	NA	4140	NA	4755	5-16d
22	5.6	18075	2935	2597	5.3	NA	2345	NA	2830	6-16d	NA	5090	NA	5705	11-16d
24	5.8	19700	3060	3172	5.3	NA	2345	NA	2830	6-16d	NA	5405	NA	6020	13-16d
26	6.1	21315	2900	3814	5.3	NA	2450	NA	2900	7-16d	NA	5800(7)	NA	5800(7)	14-16d
28	6.4	22915	2900	4525	5.3	NA	2450	NA	2900	8-16d	NA	5800(7)	NA	5800(7)	15-16d
30	6.6	24510	2900	5306	5.3	NA	2450	NA	2900	8-16d	NA	5800(7)	NA	5800(7)	17-16d
TJI H90															
11-7/8	4.6	10960	1925	687	5.3	1400	1715	1885	1925	2-16d	3495	3810	4100	4420	2-16d
14	4.9	13090	2125	1015	5.3	1400	1875	1885	2125	3-16d	3495	3970	4100	4575	3-16d
16	5.2	15065	2330	1389	5.3	1400	2030	1885	2330	4-16d	3495	4130	4100	4735	4-16d
18	5.4	17010	2535	1827	5.3	1400	2030	1885	2515	4-16d	3495	4130	4100	4735	4-16d
20	5.7	18945	2740	2331	5.3	NA	2190	NA	2675	5-16d	NA	4285	NA	4890	5-16d
22	6.0	20855	2935	2904	5.3	NA	2345	NA	2830	6-16d	NA	5235	NA	5840	11-16d
24	6.3	22755	3060	3549	5.3	NA	2345	NA	2830	6-16d	NA	5425	NA	6155	13-16d
26	6.5	24645	2900	4266	5.3	NA	2450	NA	2900	7-16d	NA	5800(7)	NA	5800(7)	14-16d
28	6.8	26520	2900	5059	5.3	NA	2450	NA	2900	8-16d	NA	5800(7)	NA	5800(7)	15-16d
30	7.1	28380	2900	5930	5.3	NA	2450	NA	2900	8-16d	NA	5800(7)	NA	5800(7)	17-16d
TJI HD90															
11-7/8	5.4	14075	2320	826	6.0	1835(9)	2320(9)	2150	2320	4-16d	3995	4650	4690	5345	4-16d
14	5.7	16920	2565	1232	6.0	1835(9)	2565(9)	2150	2565	6-16d	3995	4980	4690	5670	6-16d
16	6.0	19550	2790	1695	6.0	1835(9)	2790(9)	2150	2790	6-16d	3995	4980	4690	5670	6-16d
18	6.3	22150	3020	2239	6.0	1835(9)	3020(9)	2150	3020	8-16d	3995	5310	4690	6000	8-16d
20	6.7	24725	3250	2866	6.0	NA	3250(9)	NA	3250	10-16d	NA	5425	NA	6330	10-16d
22	7.0	27280	3480	3579	6.0	NA	3475(9)	NA	3480	10-16d	NA	5425	NA	6330	10-16d
24	7.3	29815	3710	4380	6.0	NA	3500(9)(11)	NA	3710	12-16d	NA	5425	NA	6655	12-16d
26	7.6	32330	3940	5272	6.0	NA	3500(9)(11)	NA	3940	14-16d	NA	6985(7)	NA	7675(7)	14-16d
28	7.9	34830	4165	6258	6.0	NA	3500(9)(11)	NA	4165	14-16d	NA	6985(7)	NA	7675(7)	14-16d
30	8.2	37310	4375	7339	6.0	NA	3500(9)(11)	NA	4375	16-16d	NA	7310(7)	NA	8005(7)	16-16d
32	8.5	39785	4375	8519	6.0	NA	3500(9)(11)	NA	4375	18-16d	NA	7640(7)	NA	8335(7)	18-16d
TJI HS90															
11-7/8	6.0	16050	2320	900	6.0	1835(9)	2320(9)	2150	2320	4-16d	3995	4650	4690	5345	4-16d
14	6.3	19425	2565	1355	6.0	1835(9)	2565(9)	2150	2565	6-16d	3995	4980	4690	5670	6-16d
16	6.6	22550	2790	1876	6.0	1835(9)	2790(9)	2150	2790	6-16d	3995	4980	4690	5670	6-16d
18	7.0	25640	3020	2488	6.0	1835(9)	3020(9)	2150	3020	8-16d	3995	5310	4690	6000	8-16d
20	7.3	28695	3250	3195	6.0	NA	3250(9)	NA	3250	10-16d	NA	5425	NA	6330	10-16d
22	7.6	31725	3480	3998	6.0	NA	3475(9)	NA	3480	10-16d	NA	5425	NA	6330	10-16d
24	7.9	34730	3710	4901	6.0	NA	3500(9)(11)	NA	3710	12-16d	NA	5425	NA	6655	12-16d
26	8.2	37715	3940	5905	6.0	NA	3500(9)(11)	NA	3940	14-16d	NA	6985(7)	NA	7675(7)	14-16d
28	8.5	40680	4165	7014	6.0	NA	3500(9)(11)	NA	4165	14-16d	NA	6985(7)	NA	7675(7)	14-16d
30	8.8	43630	4375	8230	6.0	NA	3500(9)(11)	NA	4375	16-16d	NA	7310(7)	NA	8005(7)	16-16d
32	9.1	46560	4375	9555	6.0	NA	3500(9)(11)	NA	4375	18-16d	NA	7640(7)	NA	8335(7)	18-16d

See notes at the end of the table.

TABLE 3—CONTINUED

BASIC PROPERTIES						REACTION PROPERTIES										
Joist Depth (in.)	Joist Weight (plf)	Resistive Moment (ft.-lbs.) (10)	Vert. Shear (lbs.)	EI x 10 ⁶ lbs.-in. ²	K	END REACTION (lbs.)					INTERMEDIATE REACTION (lbs.)					
						1-3/4"		3-1/2"			Nails Req'd for Web Stiff.	3-1/2"		5-1/4"		Nails Req'd for Web Stiff.
						2-1/2" (9)		Bearing Length				5-1/4" (7)		7" (7)		
						Bearing Length		Web Stiffeners				Bearing Length		Web Stiffeners		
NO		YES			NO		YES		NO		YES					
TJI 100C																
9 1/2	2.5	2605	1120	184	4.5	1120	NA	1120	NA	NA	2285	NA	2795	NA	NA	
11-7/8	2.7	3350	1420	314	4.5	1125	1420	1405	1420	3-8d	2285	2640	2795	3155	3-8d	
14	3.0	3915	1710	461	4.5	1125	1480	1405	1710	3-8d	2285	2640	2795	3155	3-8d	
16	3.2	4430	1970	628	4.5	1125	1480	1405	1760	3-8d	2285	2640	2795	3155	3-8d	
TJI 300C																
11-7/8	2.7	4470	1420	372	4.5	1125	1420	1405	1420	3-8d	2595	2950	3175	3535	3-8d	
14	3.0	5355	1710	545	4.5	1125	1480	1405	1710	3-8d	2595	2950	3175	3535	3-8d	
16	3.2	6085	1970	742	4.5	1125	1480	1405	1760	3-8d	2595	2950	3175	3535	3-8d	

For SI: 1 inch = 25.4 mm, 1 plf = 14.59 N/m, 1 ft.-lb. = 1.356 N-m, 1 lb.-in.² = 2.87 kN-mm.²

FOOTNOTES FOR TABLE 3:

- Refer to Figure 1 for web stiffener details.
- Deflection is calculated as follows:

$$\text{Uniform load : } \Delta = \frac{22.5WL^4}{EI} + \frac{12WL^2}{Kdx10^5}$$

$$\text{Concentrated load at midspan : } \Delta = \frac{36PL^3}{EI} + \frac{24PL}{Kdx10^5}$$

Where:

P = Concentrated load, pounds. d = Out-to-out depth of joist, inches. L = Clear span in feet
W = Uniform load in pounds per lineal foot. EI = From table. K = From table.

- The stated allowable design properties are for loads of normal duration. Adjustments to the allowable design values must be in accordance with the applicable code, with the exception noted in footnote 10 below.
- Interpolation between bearing lengths and joist depths is permitted for allowable design reactions.
- The minimum bearing length is permitted to be reduced for joists supported by hangers if supplemental nail attachment is provided to the web stiffener.
- Allowable bearing lengths have been determined based on Weyerhaeuser TJI Joist products. Allowable bearing on supporting members must be checked.
- Allowable bearing reactions for 5-1/4-inch and 7-inch bearing lengths at intermediate supports.
- Joist weights shown are calculated on a rational basis, are based on the heavier of eastern or western species products and are suitable for dead load calculation. Contact the producing plant for shipping weight information if needed.
- Applicable to TJI HD90 and TJI HS90 joists only. Areas indicate allowable bearing reactions for a 2-1/2 inch bearing length at end supports. 1-3/4 inch end bearing lengths are also permitted; with allowable reactions of 1600 lbs. without web stiffeners for depths up to and including 18 inches; with web stiffeners the allowable reaction is 2255 lbs. for the 11-7/8 inch depth and 2450 lbs. for all other depths.
- The resistive moment capacities listed in Table 3 may not be increased by any code allowed repetitive-member use factor.
- Applicable to TJI HD90 and TJI HS90 joists only. Reaction capacities based on applicable hanger seat length (interpolated as per note 4 above) may be increased 510 lbs when supported by Simpson Strong-Tie Co. HWI or WPU joist hangers with a minimum of 4 10d common nails installed through the joist hanger stirrups and into the joist web stiffener and web.

TABLE 4—PROPERTIES FOR USE IN SECTION 4.2

TJI JOIST SERIES	TJI JOIST DEPTH (inches)	V ₁₂ (lbs.)	K
TJI 110	≤ 14	1,560	15.60
TJI 210, TJI 230	≤ 16	1,655	16.55
TJI 360	≤ 16	1,705	17.05
TJI 560	≤ 20	2,050	20.50
TJI 100C, TJI 300C	≤ 16	1,420	14.20
TJI L65, TJI L90, TJI H90	≤ 24	1,925	19.25
TJI HD90, TJI HS90	≤ 24	2,320	23.20

For SI: 1 inch = 25.4 mm, 1 lb. = 4.448 N, 1 plf = 14.59 N/m.

FIGURE 1—WEB STIFFENER NOTES AND DETAILS

1. Web stiffeners must be installed at bearing points as required in Table 3.
2. Web stiffeners must be installed at points of concentrated loads greater than 1500 pounds and are to be nailed in accordance with the intermediate reaction schedule in Table 3.
3. Web stiffeners are to be installed on each side of the web as shown, with nails equally spaced vertically.
4. A gap must be left at the top of web stiffeners as shown at all bearing conditions. In the case of concentrated loads, web stiffeners are required as shown and the gap must be at the bottom.
5. Web stiffener material must be sheathing meeting the requirements of PS-1 or PS-2 with the face grain parallel to the long axis of the stiffener.
6. Some hangers require web stiffeners to comply with nailing requirements through side plates.
7. If web stiffeners are not used in hanger support, the side of the hanger must extend up to laterally support the top flange.
8. See manufacturer's published installation instructions for additional details and requirements for web stiffeners.

Web stiffener specifications are as follows:

TJI JOIST SERIES	MINIMUM DIMENSIONS		GRADE
	"W" (inches)	"T" (inches)	
TJI 110	2 5/16	5/8	See Note 5
TJI 210	2 5/16	23/32	See Note 5
TJI 230, TJI 360, TJI L65	2 5/16	7/8	See Note 5
TJI 100C, TJI 300C	2 5/16	1.0	See Note 5
TJI 560, TJI L90, TJI H90	3 1/2	1 1/2	Construction Grade 2x4
TJI HD90, TJI HS90	3 1/2	1 1/2	1.3E minimum grade TimberStrand LSL

For SI: 1 inch = 25.4 mm.

WEB STIFFENER ATTACHMENT

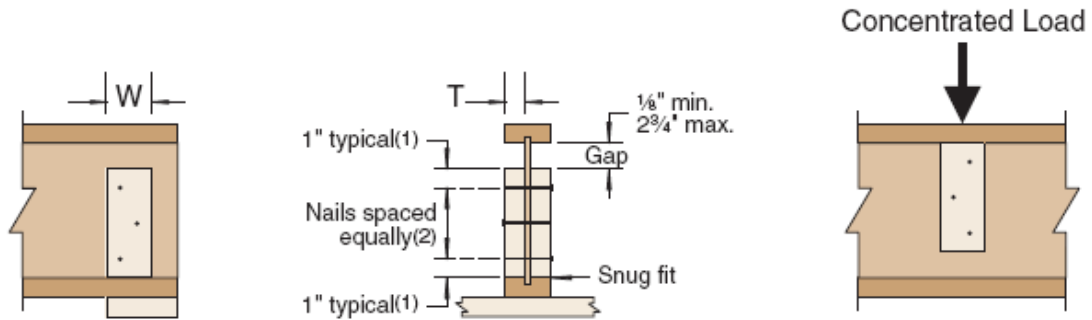

- (1) 1 1/2" typical with 2x4 sawn lumber web stiffeners
- (2) The nails may be driven from one side only

MINIMUM BEARING DISTANCE

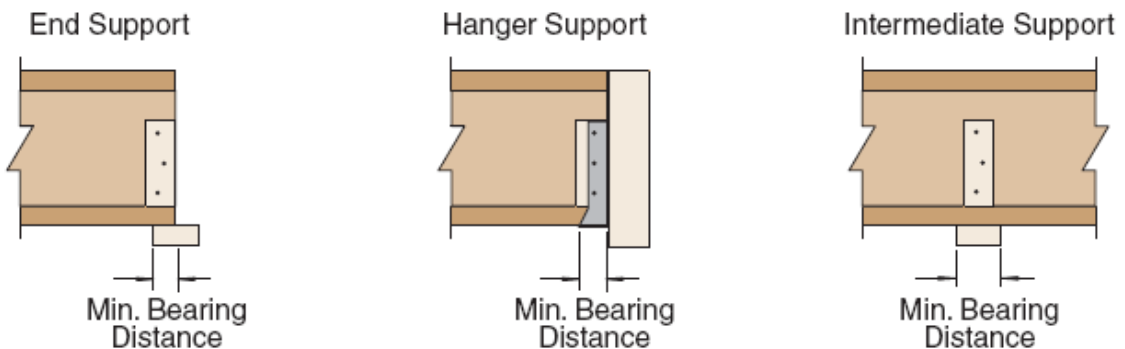

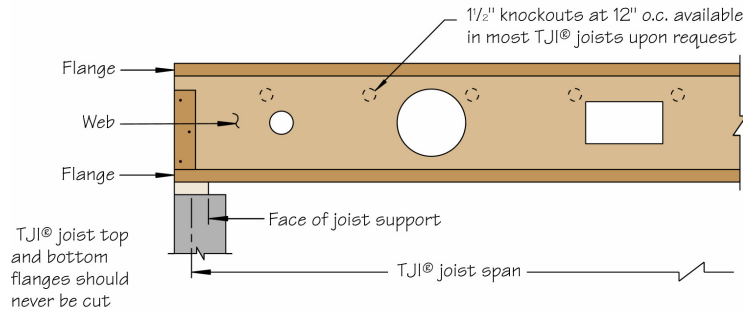

FIGURE 2—Allowable Hole Size and Location for the TJI L65, TJI L90, TJI H90, TJI HD90 and TJI HS90 Joists ONLY.

Hole Factors and Locations Chart

Round Hole Size (inches)	2	3	4	5	6	7	8	9	10	11	12	13	14	15	16	17	18	19	20		
Rectangular Hole Size (inches)	1¼	1¾	2¼	3	3½	4	4¾	5¼	6	6½	7	7¾	8¼	9	9½	10	10¾	11¼	12		
Joist depth (inches)	11⅞	A	A	B	C	E															
	14	A	A	B	C	C	D	E													
	16	A	A	A	B	C	C	D	E	E											
	18	4"	1'-3"	A	A	B	C	C	D	E	E										
	20	4"	1'-3"	A	A	B	B	C	C	D	D	E	E								
	22	4"	1'-3"	1'-3"	A	A	B	B	C	C	D	D	E	E							
	24	4"	4"	1'-3"	A	A	A	B	B	C	C	D	D	E	E	E					
	26	4"	4"	1'-3"	A	A	A	B	B	B	C	C	D	D	D	E	E				
	28	4"	4"	1'-3"	1'-3"	A	A	A	B	B	B	C	C	D	D	D	E	E	E	E	
30	4"	4"	4"	1'-3"	1'-3"	A	A	A	B	B	B	B	C	C	C	D	D	E	E	E	

Notes to Figure 2:

1. Charts are based on simple spans and uniform load applications or applicable building code provisions for concentrated loads (2000 lbs. Over 2.5 square feet) with 25 psf dead load and 20 psf partition load.
2. For uniformly loaded multiple span applications holes must be located 1.0 inch farther from the support for each foot of joist span, than the values indicated in the Charts.
3. Holes are not allowed in cantilever areas unless specifically designed by a qualified design professional.
4. Where more than one hole is to be cut in the web, the clear distance between holes must be twice the length of the longest dimension of the largest adjacent hole.
5. Hole sizes shown are hole sizes, not duct sizes.
6. Rectangular hole sizes are based on measurement of the longest side.
7. Hole locations are measured from inside face of joist support to nearest edge of hole. See Figure 3.

For SI: 1 inch = 25.4 mm, 1 foot = 304.8 mm.

Hole Locations Chart

Joist Span (center to center of support, feet)	Hole Factor				
	A	B	C	D	E
14	1'-3"	2'-0"	2'-6"	3'-9"	5'-0"
15	1'-3"	2'-0"	3'-0"	4'-0"	5'-3"
16	1'-3"	2'-3"	3'-3"	4'-6"	5'-9"
17	1'-6"	2'-9"	3'-9"	5'-0"	6'-3"
18	1'-6"	3'-0"	4'-3"	5'-6"	6'-9"
19	1'-9"	3'-0"	4'-3"	5'-6"	7'-0"
20	1'-9"	3'-0"	4'-3"	5'-6"	7'-0"
21	2'-0"	3'-0"	4'-3"	5'-9"	7'-3"
22	2'-0"	3'-0"	4'-3"	5'-9"	7'-3"
23	2'-0"	3'-3"	4'-3"	5'-9"	7'-6"
24	2'-3"	3'-3"	4'-6"	5'-9"	7'-6"
25	2'-3"	3'-6"	4'-9"	5'-9"	7'-9"
26	2'-3"	3'-9"	4'-9"	6'-0"	7'-9"
27	2'-6"	3'-9"	5'-0"	6'-3"	7'-9"
28	2'-6"	4'-0"	5'-3"	6'-6"	8'-0"
29	2'-6"	4'-0"	5'-6"	6'-9"	8'-3"
30	2'-9"	4'-3"	5'-9"	7'-0"	8'-6"
31	3'-0"	4'-3"	5'-9"	7'-3"	8'-9"
32	3'-0"	4'-6"	6'-0"	7'-6"	9'-3"
33	3'-0"	4'-9"	6'-3"	7'-9"	9'-6"
34	3'-0"	5'-0"	6'-6"	8'-0"	9'-9"
35	3'-3"	5'-0"	6'-6"	8'-3"	10'-0"
36	3'-3"	5'-0"	6'-9"	8'-6"	10'-3"

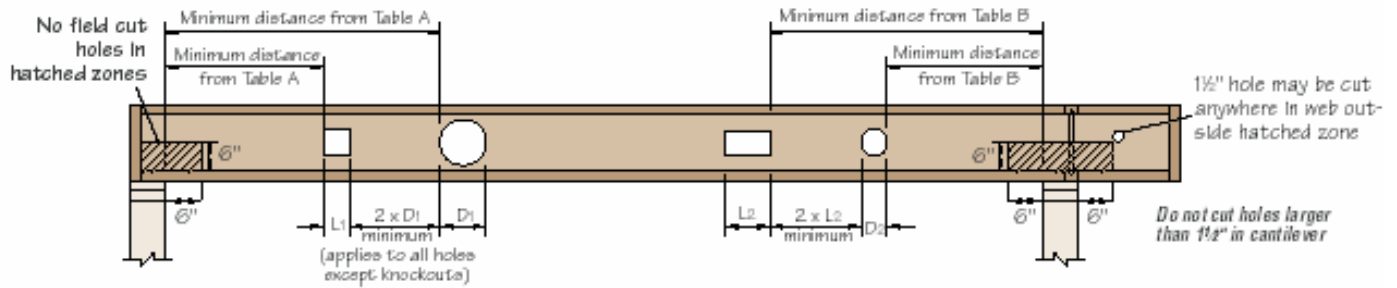

FIGURE 3—ALLOWABLE HOLE SIZE AND LOCATION FOR THE TJI 110, TJI 210, TJI 230, TJI 360 AND TJI 560 JOISTS (TABLES A AND B), AND TJI 100C AND 300C JOISTS (TABLES C AND D)

Table A – Minimum Distance From Inside Face of End Support to Nearest Edge of Hole

JOIST DEPTH (inches)	TJI JOIST SERIES	ROUND HOLE SIZE (inches)							SQUARE OR RECTANGULAR HOLE SIZE (inches)						
		2	3	4	6½	8¾	11	13	2	3	4	6½	8¾	11	13
9½	TJI 110	1'-0"	1'-6"	2'-0"	5'-0"				1'-0"	1'-6"	2'-6"	4'-6"			
	TJI 210	1'-0"	1'-6"	2'-0"	5'-0"				1'-0"	2'-0"	2'-6"	5'-0"			
	TJI 230	1'-0"	2'-0"	2'-6"	5'-6"				1'-0"	2'-0"	3'-0"	5'-0"			
11¾	TJI 110	1'-0"	1'-0"	1'-0"	2'-6"	5'-0"			1'-0"	1'-0"	1'-6"	4'-6"	6'-0"		
	TJI 210	1'-0"	1'-0"	1'-0"	2'-6"	5'-6"			1'-0"	1'-0"	2'-0"	5'-0"	6'-6"		
	TJI 230	1'-0"	1'-0"	1'-0"	3'-0"	6'-0"			1'-0"	1'-0"	2'-0"	5'-6"	7'-0"		
	TJI 360	1'-0"	1'-0"	1'-6"	4'-6"	7'-0"			1'-0"	1'-0"	2'-6"	6'-6"	7'-6"		
	TJI 560	1'-0"	1'-0"	1'-6"	5'-0"	8'-0"			1'-0"	2'-0"	3'-6"	7'-0"	8'-0"		
14	TJI 110	1'-0"	1'-0"	1'-0"	1'-0"	2'-6"	5'-0"		1'-0"	1'-0"	1'-0"	3'-6"	6'-0"	8'-0"	
	TJI 210	1'-0"	1'-0"	1'-0"	1'-0"	3'-0"	6'-0"		1'-0"	1'-0"	1'-0"	4'-0"	6'-6"	8'-6"	
	TJI 230	1'-0"	1'-0"	1'-0"	1'-6"	3'-6"	6'-6"		1'-0"	1'-0"	1'-0"	4'-0"	7'-0"	9'-0"	
	TJI 360	1'-0"	1'-0"	1'-0"	2'-6"	5'-6"	8'-0"		1'-0"	1'-0"	1'-0"	5'-6"	8'-0"	9'-6"	
	TJI 560	1'-0"	1'-0"	1'-0"	2'-6"	6'-0"	9'-0"		1'-0"	1'-0"	1'-6"	6'-6"	9'-0"	10'-0"	
16	TJI 210	1'-0"	1'-0"	1'-0"	1'-0"	1'-6"	3'-6"	6'-0"	1'-0"	1'-0"	1'-0"	2'-6"	6'-6"	8'-0"	10'-6"
	TJI 230	1'-0"	1'-0"	1'-0"	1'-0"	2'-0"	4'-0"	6'-6"	1'-0"	1'-0"	1'-0"	3'-0"	7'-0"	9'-0"	11'-0"
	TJI 360	1'-0"	1'-0"	1'-0"	1'-0"	3'-0"	6'-0"	9'-0"	1'-0"	1'-0"	1'-0"	4'-0"	9'-0"	10'-0"	11'-6"
	TJI 560	1'-0"	1'-0"	1'-0"	1'-0"	3'-0"	6'-6"	10'-0"	1'-0"	1'-0"	1'-0"	5'-0"	10'-0"	11'-0"	12'-0"

See notes below Table D.

Table B – Minimum Distance from Inside Face of Intermediate or Cantilever Support to Nearest Edge of Hole

JOIST DEPTH (inches)	TJI JOIST SERIES	ROUND HOLE SIZE (INCHES)							SQUARE OR RECTANGULAR HOLE SIZE (inches)						
		2	3	4	6½	8¾	11	13	2	3	4	6½	8¾	11	13
9½	TJI 110	1'-6"	2'-6"	3'-0"	7'-6"				1'-6"	2'-6"	3'-6"	6'-6"			
	TJI 210	2'-0"	2'-6"	3'-6"	7'-6"				2'-0"	3'-0"	4'-0"	7'-0"			
	TJI 230	2'-6"	3'-0"	4'-0"	8'-0"				2'-6"	3'-0"	4'-6"	7'-6"			
11¾	TJI 110	1'-0"	1'-0"	1'-6"	4'-0"	8'-0"			1'-0"	1'-6"	2'-6"	6'-6"	9'-0"		
	TJI 210	1'-0"	1'-0"	2'-0"	4'-6"	9'-0"			1'-0"	2'-0"	3'-0"	7'-6"	10'-0"		
	TJI 230	1'-0"	2'-0"	2'-6"	5'-0"	9'-6"			1'-0"	2'-6"	3'-6"	8'-0"	10'-0"		
	TJI 360	2'-0"	3'-0"	4'-0"	7'-0"	11'-0"			2'-0"	3'-6"	5'-0"	9'-6"	11'-0"		
	TJI 560	1'-6"	3'-0"	4'-6"	8'-0"	12'-0"			3'-0"	4'-6"	6'-0"	10'-6"	12'-0"		
14	TJI 110	1'-0"	1'-0"	1'-0"	2'-0"	4'-6"	8'-0"		1'-0"	1'-0"	1'-0"	5'-0"	9'-0"	12'-0"	
	TJI 210	1'-0"	1'-0"	1'-0"	2'-6"	5'-0"	9'-0"		1'-0"	1'-0"	2'-0"	6'-0"	10'-0"	12'-6"	
	TJI 230	1'-0"	1'-0"	1'-0"	3'-0"	5'-6"	10'-0"		1'-0"	1'-0"	2'-6"	6'-0"	10'-6"	13'-0"	
	TJI 360	1'-0"	1'-0"	2'-0"	5'-6"	8'-6"	12'-6"		1'-0"	2'-0"	4'-0"	9'-0"	12'-0"	14'-0"	
	TJI 560	1'-0"	1'-0"	1'-6"	5'-6"	9'-6"	13'-6"		1'-0"	3'-0"	5'-0"	10'-0"	13'-6"	15'-0"	
16	TJI 210	1'-0"	1'-0"	1'-0"	1'-0"	3'-0"	5'-6"	9'-6"	1'-0"	1'-0"	1'-0"	4'-6"	9'-6"	12'-6"	15'-6"
	TJI 230	1'-0"	1'-0"	1'-0"	1'-6"	4'-0"	6'-6"	10'-6"	1'-0"	1'-0"	1'-0"	5'-0"	10'-6"	13'-0"	16'-0"
	TJI 360	1'-0"	1'-0"	1'-0"	3'-0"	6'-6"	10'-0"	13'-6"	1'-0"	1'-0"	2'-0"	7'-6"	13'-0"	14'-6"	17'-0"
	TJI 560	1'-0"	1'-0"	1'-0"	2'-6"	7'-0"	11'-0"	15'-0"	1'-0"	1'-0"	3'-6"	9'-0"	14'-6"	16'-0"	18'-0"

See notes below Table D.

FIGURE 3A—ALLOWABLE HOLE SIZE AND LOCATION FOR THE TJI 100C and TJI 300C JOISTS

Table C – Minimum Distance From Inside Face of End Support to Nearest Edge of Hole

JOIST DEPTH (inches)	TJI JOIST SERIES	ROUND HOLE SIZE (inches)							SQUARE OR RECTANGULAR HOLE SIZE (inches)						
		2	3	4	6¼	8⅝	10¾	12¾	2	3	4	6¼	8⅝	10¾	12¾
9½	TJI 100C	1'-0"	1'-6"	2'-0"	5'-0"				1'-0"	1'-6"	2'-6"	4'-0"			
11⅞	TJI 100C	1'-0"	1'-0"	1'-0"	2'-6"	5'-0"			1'-0"	1'-0"	1'-6"	4'-0"	5'-6"		
	TJI 300C	1'-0"	1'-0"	1'-6"	3'-0"	6'-6"			1'-0"	1'-0"	2'-0"	5'-0"	6'-6"		
14	TJI 100C	1'-0"	1'-0"	1'-0"	1'-0"	2'-6"	5'-0"		1'-0"	1'-0"	1'-0"	3'-0"	5'-0"	6'-6"	
	TJI 300C	1'-0"	1'-0"	1'-0"	1'-6"	3'-6"	7'-0"		1'-0"	1'-0"	1'-0"	4'-0"	6'-6"	8'-0"	
16	TJI 100C	1'-0"	1'-0"	1'-0"	1'-0"	1'-0"	3'-0"	5'-0"	1'-0"	1'-0"	1'-0"	2'-0"	5'-0"	6'-6"	8'-0"
	TJI 300C	1'-0"	1'-0"	1'-0"	1'-0"	1'-6"	4'-0"	7'-0"	1'-0"	1'-0"	1'-0"	2'-6"	6'-6"	8'-0"	10'-0"

See notes below Table D.

Table D—Minimum Distance from Inside Face of Intermediate or Cantilever Support to Nearest Edge of Hole

JOIST DEPTH (inches)	TJI JOIST SERIES	ROUND HOLE SIZE (inches)							SQUARE OR RECTANGULAR HOLE SIZE (inches)						
		2	3	4	6¼	8⅝	10¾	12¾	2	3	4	6¼	8⅝	10¾	12¾
9½	TJI 100C	1'-6"	2'-6"	3'-0"	7'-6"				1'-6"	2'-6"	3'-6"	6'-0"			
11⅞	TJI 100C	1'-0"	1'-6"	2'-0"	4'-0"	8'-0"			1'-0"	2'-0"	3'-0"	6'-0"	8'-0"		
	TJI 300C	1'-6"	2'-6"	3'-0"	5'-0"	10'-0"			1'-6"	3'-0"	4'-0"	7'-6"	9'-6"		
14	TJI 100C	1'-0"	1'-0"	1'-0"	2'-0"	4'-6"	8'-0"		1'-0"	1'-0"	2'-0"	4'-6"	8'-0"	10'-6"	
	TJI 300C	1'-0"	1'-0"	1'-6"	3'-6"	6'-0"	10'-6"		1'-0"	2'-0"	3'-0"	6'-0"	10'-0"	12'-0"	
16	TJI 100C	1'-0"	1'-0"	1'-0"	1'-0"	2'-6"	4'-6"	7'-6"	1'-0"	1'-0"	1'-0"	3'-6"	7'-6"	9'-6"	12'-6"
	TJI 300C	1'-0"	1'-0"	1'-0"	2'-0"	4'-0"	6'-6"	11'-0"	1'-0"	1'-0"	2'-0"	5'-0"	10'-0"	12'-0"	15'-0"

For SI: 1 inch = 25.4 mm, 1 foot = 304.8 mm.

1. The clear distance between multiple holes must be twice the length of the longest dimension of the largest hole.
2. Holes may be located vertically anywhere within the web. Leave 1/8 inch of web minimum at top and bottom of hole.
3. Table A (simple and continuous spans) and Table B (continuous spans) are based on uniform load applications, within the limitations of the applicable Weyerhaeuser literature.
4. TJI Joists are manufactured with 1 1/2 inch diameter perforated knockouts in the web at approximately 12 inches on center along the length of the joist.
5. For simple span (5 foot minimum) uniformly loaded joists one maximum size hole may be located in the web at the center of the joist span provided no other holes occur in the joist.

FIGURE 4—ONE-HOUR FIRE-RESISTIVE ASSEMBLY DETAILS

ASSEMBLY A (See Section 4.17.1)

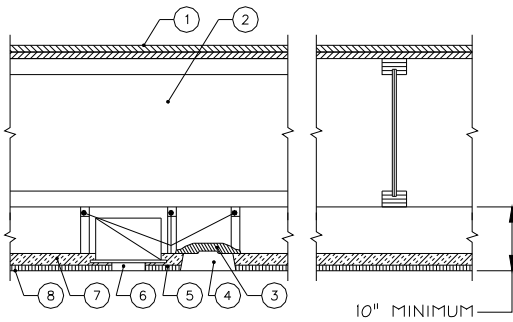

1. Double Wood Floor.
2. TJI Joist with minimum 1-1/2 inch flange depth.
3. Fixture protection.
4. 24 inch x 48 inch recessed light fixture.
5. Cold-rolled channels.
6. 12 inch air diffuser.
7. Thermafiber, Fibrex-FBX, Fibrex-IF or IIG MinWool mineral wool blankets.
8. 5/8-inch thick acoustical panels 24 inches x 24 inches or 24 inches x 48 inches supported by an approved exposed fire-rated suspension system.

ASSEMBLY B (See Section 4.17.2)

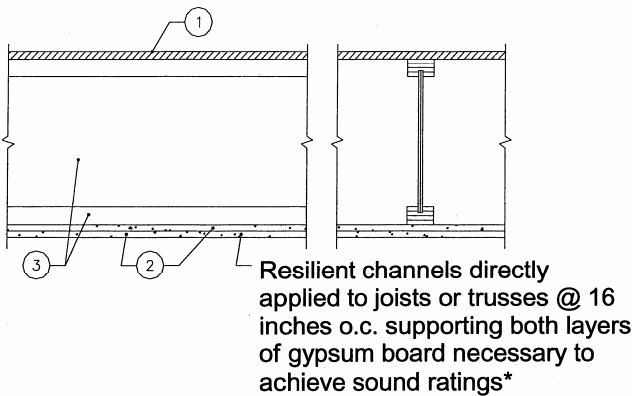

1. 48/24 tongue-and-groove span rated sheathing (Exposure 1), nailed and glued to the TJI joists with construction adhesive conforming to ASTM D3498.
2. Two layers of 1/2 inch thick Type C, or 5/8-inch-thick Type X gypsum board.
3. TJI Joist.
4. Optional minimum 3-1/2 inch thick glass fiber insulation or glass fiber insulation rated R-30 or less, with resilient channels (not shown).

Sound Test Data*

W/O Gypsum Concrete	STC = 50	
	Pad & Carpet	IIC = 60
	Tarkett Acoustiflor	IIC = 51 (1)
	Cushioned vinyl	IIC = 45 (2)
W/Gypsum Concrete	STC = 58	
	Pad & Carpet	IIC = 54
	Tarkett Acoustiflor	IIC = 54 (1)
	Armstrong Vios/Armstrong	IIC = 50 (1)
	Cambray sheet vinyl	

- (1) Requires two layers of 5/8-inch thick Type X gypsum board with minimum 3-1/2 inch thick glass fiber insulation or glass fiber insulation rated R-30 or less.
- (2) Applicable only in jurisdictions using the IRC, BNBC or SBC.

ASSEMBLY C (See Section 4.17.3)

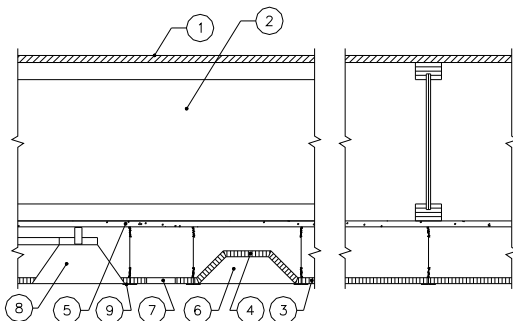

1. 48/24 tongue-and-groove span rated sheathing (Exposure 1), nailed and glued to the TJI joists with construction adhesive conforming to ASTM D3498.
2. TJI Joist.
3. 5/8 inch thick x 24 inch x 24 inch ceiling panels.
4. Fixture protection.
5. 1/2 inch thick Type C, or 5/8-inch-thick Type X gypsum board.
6. 24 inch x 48 inch recessed light fixture.
7. 6 inch x 12 inch opening for return air.
8. 12 inch diameter diffuser opening.
9. Steel suspension grid.

For SI: 1 inch = 25.4 mm.

ASSEMBLY D (See Section 4.17.4)

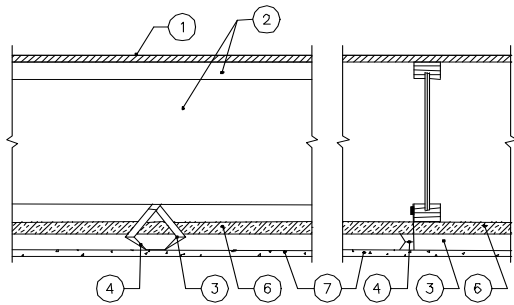

1. 48/24 tongue-and-groove span-rated sheathing (Exposure 1).
2. TJI Joist with minimum 1.375 inch flange depth.
3. No. 26 gauge galvanized steel furring channel installed perpendicular to joists. Furring channels spaced 1-1/2 inches from and on each side of wallboard end joints and 24 inches on center away from end joints. Channel secured to joists with support clips (Item 4) at each joist location. At channel splices, adjacent pieces overlapped 6 inches and tied with double strand of No. 18 SWG galvanized steel wire at each end of overlap.
4. Simpson Strong-Tie Co. Type CSC support clips to be used to support furring channels at the intersection with each joist. Support clips nailed to side of joist bottom flange with 1-1/2 inch long No. 11 gauge nail.
5. Stabilizer strap (not shown) - 3/4 inch x 6 inch No. 24 gauge galvanized steel strap used to prevent rotation of the support clips at wallboard end joints and along walls.
6. 1 inch thick, 6 pcf minimum, Thermafiber, Fibrex-FBX, Fibrex-IF or IIG MinWool mineral wool blankets.
7. 1/2 inch thick USG Type C FIRECODE or ProRoc Type C gypsum board.

Sound Test Data:

W/Gypsum Concrete	STC = 59
	Pad & Carpet IIC = 54
Without Gypsum Concrete	STC = 47 (1)
	Pad & Carpet IIC = 54

(1) Applicable only in jurisdictions using the IRC, BNBC or SBC.

ASSEMBLY E (See Section 4.17.5)

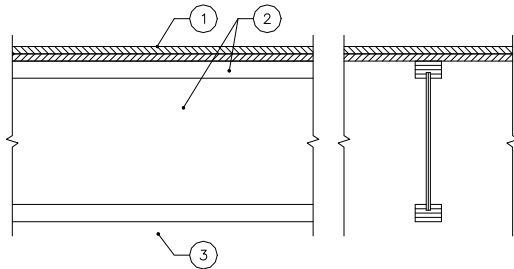

1. Double wood floor or a single layer of 48/24 span-rated tongue-and-groove sheathing (Exposure 1). Where a single layer is used, sheathing must be nailed and glued to the TJI joists with construction adhesive conforming to ASTM D3498.
2. TJI Joist.
3. An approved ceiling system that will provide a 40-minute finish rating. An example of a ceiling with a 40-minute finish rating is described in Section 4.17.2.

ASSEMBLY F (See Section 4.17.6)

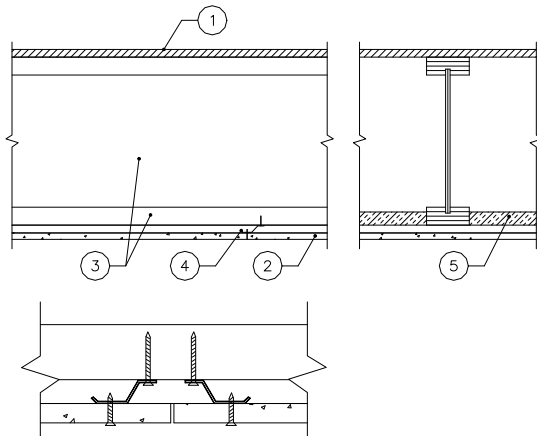

1. 48/24 tongue-and-groove span rated sheathing (Exposure 1).
2. 5/8 inch thick USG Type C FIRECODE or ProRoc Type C gypsum board.
3. TJI Joist (with flange sizes 2x4 nominal or larger).
4. USG RC-1 channel at 16 inches on center.
5. Thermafiber, Fibrex-FBX, Fibrex-SAFB or IIG MinWool SAFB mineral wool batts.

For SI: 1 inch = 25.4 mm.

TYPICAL DETAIL FOR BUTT JOINTS PERPENDICULAR TO FRAMING MEMBERS.

ASSEMBLY G (See Section 4.18)

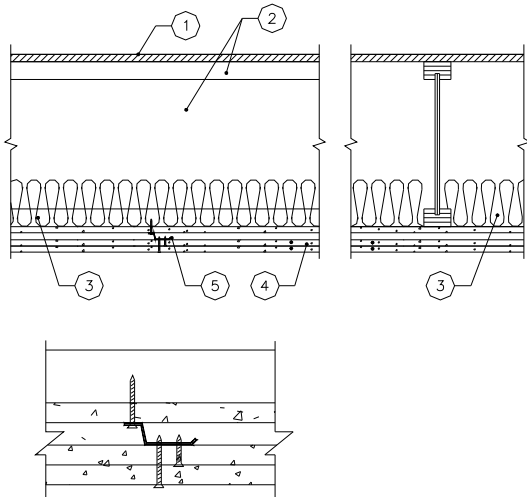

1. 48/24 tongue-and-groove span rated sheathing (Exposure 1).
2. TJI joists, 24 inches on center maximum.
3. Optional glass fiber insulation, unfaced batts, 3-1/2 inches thick in plenum, supported by stay wires 12 inches on center and centered on joist bottom flanges.
4. Three layers of 5/8 inch thick Gold Bond Fire-Shield C, Type X gypsum board.
5. Resilient channels at 16 inches on center located between first and second layers of gypsum board.

For SI: 1 inch = 25.4 mm.

Typical resilient channel and gypsum board attachment.

FIGURE 5—TWO-HOUR FIRE-RESISTANCE-RATED FLOOR-CEILING OR ROOF-CEILING ASSEMBLY

Alternate Floor or Roof Systems:

Lightweight concrete or gypsum concrete may be added to Assemblies A, B, C, D, E, F, and G in accordance with Section 4.19.

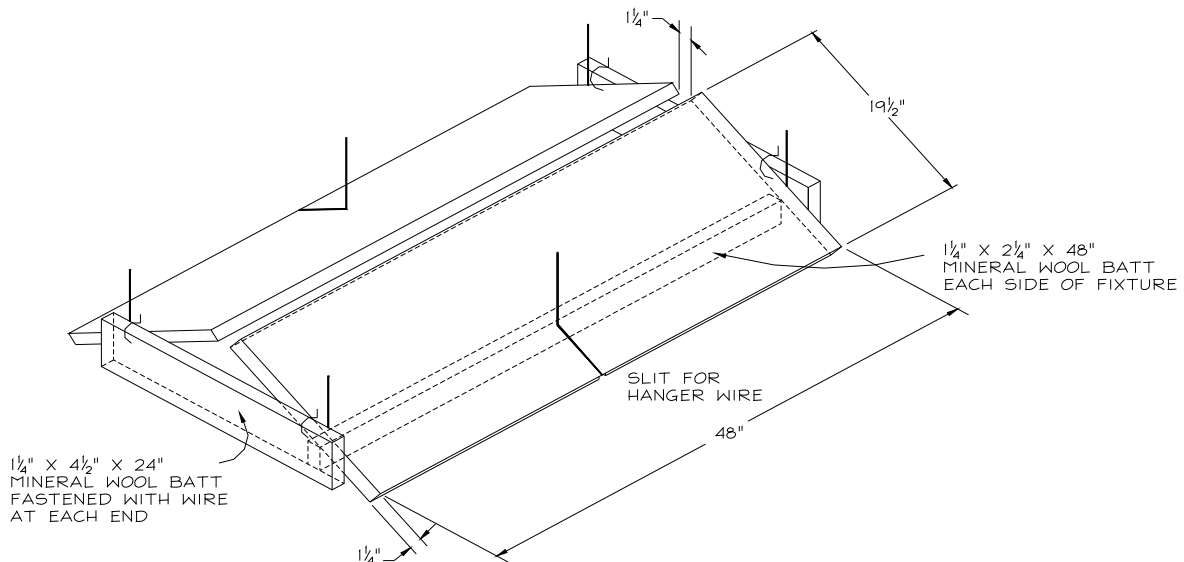
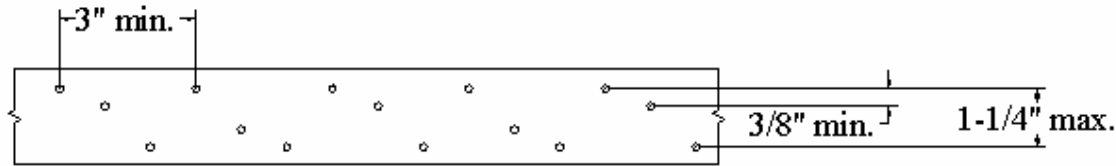

FIGURE 6—LIGHT FIXTURE PROTECTION
 (See Section 4.17.1, Item 5 for detailed description of mineral wool batts.)
 For SI: 1 inch = 25.4 mm.

FIGURE 7—METAL STRAP AND TENSION-TIE CONNECTION CAPACITIES AND DETAILS FOR TJI JOISTS

Detail A:

3 rows of 10d x 1.5" nails at 3" o.c.

Detail A is applicable to all TJI Joists with structural composite lumber flange widths of 2.5 inches or greater. Simpson Strong-Tie Co. MSTI or PAI straps, or other straps of the same minimum gauge, dimensions, grade of steel and nail patterns and recognized in a current ICC-ES Report or ICC-ES Legacy Report may be used.

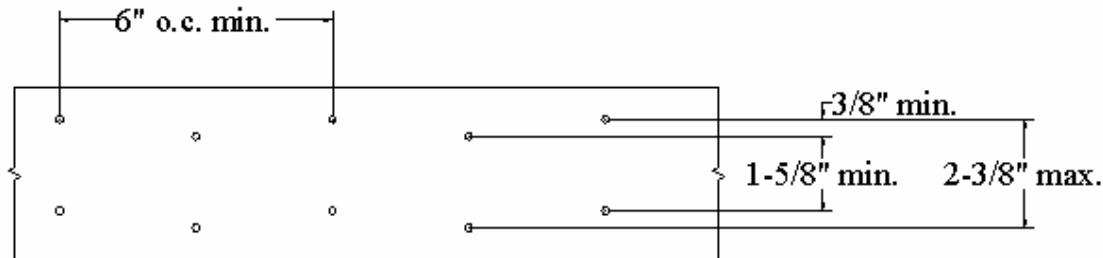
Detail B:

4 rows of 10d x 1.5" nails at 6" o.c.

Detail B is applicable to all TJI Joists with structural composite lumber flange widths of 3.5 inches or greater. Simpson Strong-Tie Co. LSTI or LTTI straps, or other straps of the same minimum gauge, dimensions, grade of steel and nail patterns and recognized in a current ICC-ES Report or ICC-ES Legacy Report may be used.

General Notes:

Connection capacity limited to a lateral nail design value of 112 lbs/nail with the following conditions.

1. All nails must be 10d short nails, 0.148 inches x 1.5 inches.
2. Minimum steel thickness must be 18 gauge (0.049 inches).
3. Total connection capacity must not exceed the code approved strap or tension-tie design value.
4. The connection capacity is permitted to be increased for duration of load in accordance with the code.
5. No additional reductions are necessary due to penetration.
6. The minimum required end distance must be 3 inches.

For **SI**: 1 inch = 25.4 mm, 1 lbf. = 4.448 N.